



SAMSUNG ELECTRONICS Co., Ltd.,
Regulatory Compliance Group
IT R&D Center

416, Maetan-3dong,
Yeongtong-gu, Suwon-si,
Gyeonggi-do, Korea 443-742

TEST REPORT ON SAR

Model Tested: GT-S3770Y
FCC ID (Requested): A3LGTS3770Y
Job No: FI-320
Report No: FI-320-S1

- Abstract -

This document reports on SAR Tests carried out in accordance with FCC/OET Bulletin 65, Supplement C(June 2001).

Prepared By

BH JEON - Test Engineer

Authorized By

JD JANG - Technical Manager

FCC ID: A3LGTS3770Y	Report Number: FI-320-S1		Page :	1 of 35
 SAMSUNG Electronics CO. LTD	EUT Type:	850/1900 GSM/GPRS Phone with Bluetooth, WLAN and EDGE Rx only	Issue Date :	Jan.17, 2012

Contents

1. GENERAL INFORMATION	3
2. DESCRIPTION OF DEVICE	3
3. DESCRIPTION OF TEST EQUIPMENT	4
3.1 SAR Measurement Setup	4
3.2 E-field Probe	5
3.3 Phantom.....	7
3.4 Brain Simulating Mixture Characterization	9
3.5 Device Holder for Transmitters.....	9
3.6 Validation Dipole	10
3.7 Equipment Calibration.....	11
4. SAR MEASUREMENT PROCEDURE.....	12
5. DESCRIPTION OF TEST POSITION	13
5.1 SAM Phantom Shape.....	13
5.2 “cheek” Position	13
5.3 “tilted” Position	15
5.4 Body Holster/Belt Clip Configurations	16
6. MEASUREMENT UNCERTAINTY	18
7. SYSTEM VERIFICATION.....	21
7.1 Tissue Verification	21
7.2 Test System Validation	21
8. SAR MEASUREMENT RESULTS.....	22
8.1 GSM850 Head SAR Results	27
8.2 GPRS850 Body SAR Results(Without Holster).....	28
8.3 GSM1900 Head SAR Results	29
8.4 GPRS1900 Body SAR Results(Without Holster).....	30
8.5 WLAN Head SAR Results.....	31
8.6 WLAN Body SAR Results(Without Holster)	32
9. CONCLUSION	33
10. REFERENCES	34
APPENDIX A SAR Definition	36
APPENDIX B Probe Calibration Process	37
APPENDIX C ANSI/IEEE C95.1 – 2005 RF EXPOSURE LIMITS.....	38
APPENDIX D The Validation Measurements	39
APPENDIX E Plots of The SAR Measurements.....	46
APPENDIX F Probe Calibration	72
APPENDIX G Calibration of The Validation Dipole	95

FCC ID: A3LGTS3770Y	Report Number: FI-320-S1		Page :	2 of 35
 SAMSUNG Electronics CO. LTD	EUT Type:	850/1900 GSM/GPRS Phone with Bluetooth, WLAN and EDGE Rx only	Issue Date :	Jan.17, 2012

1. GENERAL INFORMATION

Test Dates : Jan.12, 2012 ~ Jan.13, 2012
Manufacturer : SAMSUNG ELECTRONICS Co., Ltd.
Address : 416 Maetan3-Dong, Suwon City, Korea
Test Standard : §2.1093; FCC/OET Bulletin 65, Supplement C(June 2001)
FCC Classification : Licensed Portable Transmitter Held to Ear (PCE)
Digital Transmitter System (DTS)
Tested for : FCC/TCB Certification

2. DESCRIPTION OF DEVICE

Test Sample : 850/1900 GSM/GPRS/WCDMA/HSDPA Phone with Bluetooth,
WLAN and EDGE Rx only
Model Number : GT-S3770Y
Serial Number : Identical prototype (S/N : # FI-320-E)
Tx Freq.Range : 824.2 ~ 848.8 MHz (GSM850)
1850.20 ~ 1909.80 MHz (GSM1900)
2412 ~ 2462 MHz (WLAN)
2402 ~ 2480 MHz (Bluetooth)
Rx Freq.Range : 869.2 ~ 893.8 MHz (GSM850)
1930.20 ~ 1989.80 MHz (GSM1900)
2412 ~ 2462 MHz (WLAN)
2402 ~ 2480 MHz (Bluetooth)
Antenna Manufacturer : Skycross
Model No.: MAIN ANT
Antenna Dimensions : 12.93 X 48.29 X 3.58 (mm)
Separation distance between
Main and Bluetooth antenna : 70.84 mm

FCC ID: A3LGTS3770Y	Report Number: FI-320-S1		Page :	3 of 35
 SAMSUNG Electronics CO. LTD	EUT Type:	850/1900 GSM/GPRS Phone with Bluetooth, WLAN and EDGE Rx only	Issue Date :	Jan.17, 2012

3. DESCRIPTION OF TEST EQUIPMENT

3.1 SAR Measurement Setup

Robotic System

Measurements are performed using the DASY4 (or DASY5) automated dosimetric assessment system. Which is made by Schmid & Partner Engineering AG (SPEAG) in Zurich, Switzerland and consists of high precision robotics system (Stäubli), robot controller, measurement server, Samsung computer, near-field probe, probe alignment sensor, and the SAM twin phantom containing the brain equivalent material. The robot is a six-axis industrial robot performing precise movements to position the probe to the location (points) of maximum electromagnetic field (EMF) (see Fig. 3.1).

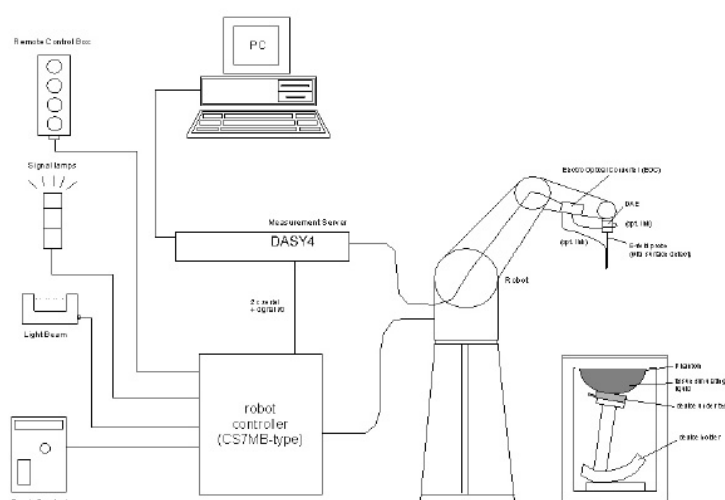



Figure 3.1 SAR Measurement System Setup

System Hardware

A cell controller system contains the power supply, robot controller, teach pendant (Joystick), and a remote control is used to drive the robot motors. The PC consists of the Samsung computer with Windows XP system and SAR Measurement Software DASY4 (or DASY5), LCD monitor, mouse and keyboard. The Stäubli Robot is connected to the cell controller to allow software manipulation of the robot. A data acquisition electronic (DAE) circuit that performs the signal amplification, signal multiplexing, AD-conversion, offset measurements, mechanical surface detection, collision detection, etc. is connected to the Electro-optical coupler (EOC). The EOC performs the conversion from the optical into digital electric signal of the DAE and transfers data to the measurement server.

FCC ID: A3LGTS3770Y	Report Number: FI-320-S1		Page :	4 of 35
 SAMSUNG Electronics CO. LTD	EUT Type:	850/1900 GSM/GPRS Phone with Bluetooth, WLAN and EDGE Rx only	Issue Date :	Jan.17, 2012

System Electronics

The DAE4(or DAE3) consists of a highly sensitive electrometer-grade preamplifier with auto-zeroing, a channel and gain-switching multiplexer, a fast 16-bit AD-converter and a command decoder and control logic unit. Transmission to the measurement server is accomplished through an optical downlink for data and status information and an optical uplink for commands and clock lines. The mechanical probe mounting device includes two different sensor systems for frontal and sidewise probe contacts. They are also used for mechanical surface detection and probe collision detection. The robot uses its own controller with a built in VME-bus computer.

3.2 E-field Probe



The SAR measurement were conducted with the dosimetric probe ES3DV2, ES3DV3, EX3DV4 and ET3DV6, designed in the classical triangular configuration (see Fig.3.3) and optimized for dosimetric evaluation. The probe is constructed using the thick film technique; with printed resistive lines on ceramic substrates. If the probe is flatly touching the surface, the coupling is zero. The distance of the coupling maximum to the surface is independent of the surface reflectivity and largely independent of the surface to probe angle. The DASY4 software reads the reflection during a software approach and looks for the maximum using a 2nd order fitting (see Fig.3.2). The approach is

Figure 3.2 DAE System stopped at reaching the maximum.

Probe Specifications

- Construction Symmetrical design with triangular core
- Interleaved sensors
- Built-in shielding against static charges
- PEEK enclosure material (resistant to organic solvents, e.g., DGBE)
- Calibration Basic Broad Band Calibration in air: 10-3000 MHz
- Conversion Factors (CF) for HSL 900 and HSL 1800

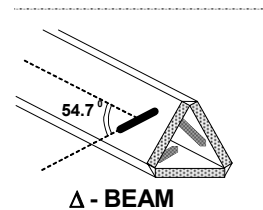



Figure 3.3 Triangular Probe Configuration

Additional CF for other liquids and frequencies upon request

FCC ID: A3LGTS3770Y	Report Number: FI-320-S1		Page :	5 of 35
 SAMSUNG Electronics CO. LTD	EUT Type:	850/1900 GSM/GPRS Phone with Bluetooth, WLAN and EDGE Rx only	Issue Date :	Jan.17, 2012

Frequency 10 MHz to > 6 GHz; Linearity: ± 0.2 dB (30 MHz to 3 GHz)

Directivity **[ES3DV3], [ET3DV6]**
 ± 0.2 dB in HSL (rotation around probe axis)
 ± 0.3 dB in tissue material (rotation normal to probe axis)
[EX3DV4]
 ± 0.3 dB in HSL (rotation around probe axis)
 ± 0.5 dB in tissue material (rotation normal to probe axis)

Dynamic Range **[ES3DV3], [ET3DV6]**
 $5\mu\text{W/g}$ to $> 100\text{mW/g}$; Linearity: $\pm 0.2\text{dB}$
[EX3DV4]
 $10\ \mu\text{W/g}$ to $> 100\ \text{mW/g}$; Linearity: $\pm 0.2\ \text{dB}$

Dimensions **[ES3DV3], [ES3DV2]**
Overall length: 330 mm (Tip: 20 mm)
Tip diameter: 3.9 mm (Body: 12 mm)
Distance from probe tip to dipole centers: 2.1 mm
[EX3DV4]
Overall length: 330 mm (Tip: 20 mm)
Tip diameter: 2.5 mm (Body: 12 mm)
Typical distance from probe tip to dipole centers: 1 mm



[ES3DV3], [ES3DV2]

[ET3DV6]
Overall length: 330mm
Tip length: 16mm
Body diameter: 12mm
Tip diameter: 6.8mm
Distance from probe tip to dipole centers: 2.7mm



[EX3DV4]

FCC ID: A3LGTS3770Y	Report Number: FI-320-S1		Page :	6 of 35
 SAMSUNG Electronics CO. LTD	EUT Type:	850/1900 GSM/GPRS Phone with Bluetooth, WLAN and EDGE Rx only	Issue Date :	Jan.17, 2012

Application **[ES3DV3], [ES3DV2]**
 General dosimetry up to 5 GHz Dosimetry in strong gradient fields Compliance tests of mobile phones

[EX3DV4]
 High precision dosimetric measurements in any exposure scenario (e.g., very strong gradient fields). Only probe which enables compliance testing for frequencies up to 6 GHz with precision of better 30 %.

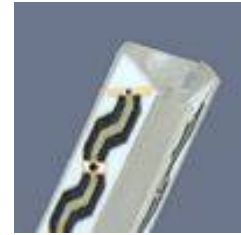

[ET3DV6]

[ET3DV6]
 General dosimetry up to 3 GHz
 Compliance tests of mobile phones
 Fast automatic scanning in arbitrary phantoms

Optical **[ET3DV6]**
 Surface ± 0.2 mm repeatability in air and clear liquids over diffuse reflecting surfaces
 Detection

3.3 Phantom

SAM Twin Phantom

The SAM Twin Phantom V4.0 is constructed of a fiberglass shell integrated in a wooden table. The shape of the shell is based on data from an anatomical study designed to determine the maximum exposure in at least 90% of all users. It enables the dosimetric evaluation of left and right hand phone usage as well as body mounted usage at the flat phantom region. A cover prevents the evaporation of the liquid.

Reference markings on the phantom allow the complete setup of all predefined phantom positions and measurement grids by manually teaching three points in the robot. (See Figure 3.5)



Figure3.5 SAM Twin Phantom

FCC ID: A3LGTS3770Y	Report Number: FI-320-S1		Page :	7 of 35
 SAMSUNG Electronics CO. LTD	EUT Type:	850/1900 GSM/GPRS Phone with Bluetooth, WLAN and EDGE Rx only	Issue Date :	Jan.17, 2012

SAM Twin Phantom Specification

Construction	The shell corresponds to the specifications of the Specific Anthropomorphic Mannequin (SAM) phantom defined in IEEE 1528-2003, EN 50361:2001 and IEC 62209. It enables the dosimetric evaluation of left and right hand phone usage as well as body mounted usage at the flat phantom region. A cover prevents evaporation of the liquid.
Shell Thickness	2 ± 0.2 mm
Filling Volume	Approx. 25 liters
Dimensions	Height: 810 mm; Length: 1000 mm; Width: 500 mm

Modular Flat Phantom

The Modular Flat Phantom V5.1 is constructed of a fiberglass shell integrated in a wooden table. Also It consists of three identical flat phantoms (modules) which can be installed and removed separately without emptying the liquid, as well as a wooden support.. It enables the dosimetric evaluation of body mounted usage at the flat phantom region. A cover prevents the evaporation of the liquid.

Reference markings on the phantom allow the complete setup of all predefined phantom positions and measurement grids by manually teaching three points in the robot. (See Figure 3.6)



Figure 3.6 Modular Flat Phantom

Modular Flat Phantom Specification

Construction	The shell corresponds to the specifications of IEEE 1528-2003. It enables the dosimetric evaluation of body mounted usage above 800 MHz at the flat phantom region. A cover prevents evaporation of the liquid
Shell Thickness	2 ± 0.2 mm
Filling Volume	Approx. 10 liters
Dimension	Wooden support - Height: 810 mm; Length: 830 mm; Width: 500 mm Each Module - Height:190 mm; Length: 200 mm; width: 300 mm

FCC ID: A3LGTS3770Y	Report Number: FI-320-S1		Page :	8 of 35
 SAMSUNG Electronics CO. LTD	EUT Type:	850/1900 GSM/GPRS Phone with Bluetooth, WLAN and EDGE Rx only	Issue Date :	Jan.17, 2012

3.4 Brain Simulating Mixture Characterization

The brain mixtures consist of a viscous gel using hydroxethylcellulose (HEC) gelling agent and saline solution (see Table 3.1). Preservation with a bactericide is added and visual inspection is made to make sure air bubbles are not trapped during the mixing process. The mixture is calibrated to obtain proper dielectric constant (permittivity) and conductivity of the desired tissue.

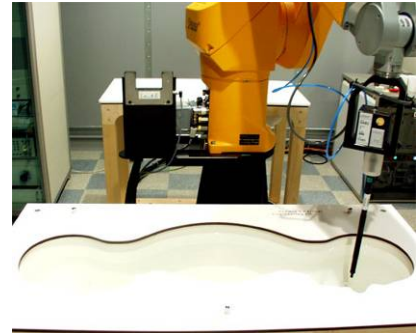

Figure3.7 Simulated Tissue

Table 3.1 Composition of the Brain Tissue Equivalent Matter

INGREDIENTS	835MHz Brain	835MHz Muscle	1900MHz Brain	1900MHz Muscle	2450MHz Brain	2450MHz Muscle
WATER	40.29%	50.75%	55.24%	70.23%	62.7%	73.2%
SUGAR	57.90%	48.21%	-	-	-	-
SALT	1.38%	0.94%	0.24%	0.21%	-	0.04%
TWEEN20	-	-	44.52%	29.56%	37.3%	26.76%
BACTERIACIDE	0.18%	0.10%	-	-	-	-
HEC	0.25%	-	-	-	-	-
Dielectric Constant Target	41.50	55.20	40.00	53.30	39.2	52.7
Conductivity Target (S/m)	0.900	0.970	1.400	1.520	1.80	1.95

3.5 Device Holder for Transmitters

In combination with the Twin SAM Phantom V4.0, the Mounting Device (see Fig. 3.7) enables the rotation of the mounted transmitter in spherical coordinates whereby the rotation points is

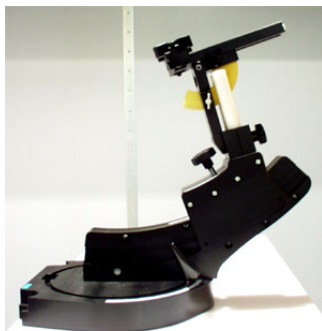

the ear opening. The devices can be easily, accurately and repeatedly be positioned according to the EN 50360:2001 and FCC specifications. The device holder can be locked at different phantom locations (left head, right head, flat phantom).

*Note: A simulating human hand is not used due to the complex anatomical and geometrical structure of the hand that may produced infinite number of configuration. To produce worst-case condition (the hand absorbs antenna output power), the hand is omitted during the tests.

Figure3.8 Device Holder

FCC ID: A3LGTS3770Y	Report Number: FI-320-S1		Page :	9 of 35
 SAMSUNG Electronics CO. LTD	EUT Type:	850/1900 GSM/GPRS Phone with Bluetooth, WLAN and EDGE Rx only	Issue Date :	Jan.17, 2012

3.6 Validation Dipole

The reference dipole should have a return loss better than -20 dB (measured in the setup) at the resonant frequency to reduce the uncertainty in the power measurement.

Frequency	835, 1900, 2450 MHz
Return Loss	< -20 dB at specified validation position
Dimensions	D835V2: dipole length: 161 mm; overall height: 330 mm D1900V2: dipole length: 68 mm; overall height: 300 mm D2450V2: dipole length: 51.8 mm; overall height: 300 mm

Note:

Usage of SAR dipoles calibrated less than 2 years ago but more than 1 year ago were confirmed in maintaining return loss (< -20dB, within 20% of prior calibration) and impedance (within 5 ohm from prior calibration) requirements per extended calibration in KDB 450824

- End of page -

FCC ID: A3LGTS3770Y	Report Number: FI-320-S1		Page :	10 of 35
 SAMSUNG Electronics CO. LTD	EUT Type:	850/1900 GSM/GPRS Phone with Bluetooth, WLAN and EDGE Rx only	Issue Date :	Jan.17, 2012

3.7 Equipment Calibration

Table 3.2 Test Equipment Calibration

Type	Calibration Due Date	Serial No.
SPEAG E-Field Probe EX3DV4	Apr.14, 2012	3750
SPEAG E-Field Probe EX3DV4	May.20, 2012	3017
SPEAG DAE4	Sep.21, 2012	533
SPEAG DAE4	May.13, 2012	468
SPEAG Validation Dipole D835V2	Feb.23, 2013	4d050
SPEAG Validation Dipole D1900V2	Feb.23, 2013	5d082
SPEAG Validation Dipole D2450V2	Apr.19, 2013	708
Stäubli Robot RX90BL	Not Required	F02/5R79A1/A/01
SPEAG SAM Twin Phantom V4.0	Not Required	TP-1604
SPEAG SAM Twin Phantom V4.0	Not Required	TP-1143
Modular Phantom	Not Required	1001
E4438C Signal Generator	Jan.26, 2012	MY45094010
NRVD Dual Channel Power Meter	Feb.07, 2012	836416/028
NRV-Z53 Thermal Power Sensor	Feb.07, 2012	835324/001
NRV-Z53 Thermal Power Sensor	Feb.07, 2012	835324/006
E4419B Power Meter	Oct.12, 2012	GB41293847
E9300B Power Sensor	Jan.28, 2012	MY41495557
BBS3Q7ECK Power Amp	Jan.20, 2012	1052
HP-8753ES Network Analyzer	Oct.12, 2012	US39173712
HP85070C Dielectric Probe Kit	Not Required	US99360087
DASY4 S/W (ver 4.7)	Not Required	-
E4440A Spectrum Analyzer	Feb.24, 2012	MY45304704
778D Dual Directional Coupler	May.18, 2012	18862
777D Dual Directional Coupler	Mar.24, 2012	07526
Base Station Simulator	Feb.09, 2012	GB43460148
Spectrum Analyzer	Mar.08,2012	MY46187454
Communication tester(E5515C)	Dec.19,2012	GB42230535
11636B	Jul.05,2012	51942

NOTE:

The E-field probe was calibrated by SPEAG, by temperature measurement procedure. Dipole Validation measurement is performed by Samsung Lab. before each test. (see § 7.2) The brain simulating material is calibrated by Samsung using the dielectric probe system and network analyzer to determine the conductivity and permittivity (dielectric constant) of the brain-equivalent material. (see § 7.1)

FCC ID: A3LGTS3770Y	Report Number: FI-320-S1		Page :	11 of 35
 SAMSUNG Electronics CO. LTD	EUT Type:	850/1900 GSM/GPRS Phone with Bluetooth, WLAN and EDGE Rx only	Issue Date :	Jan.17, 2012

4. SAR MEASUREMENT PROCEDURE

The evaluation was performed using the following procedure.

STEP 1

The SAR measurement was taken at a selected spatial reference point to monitor power variations during testing. This fixed location point was measured and used as a reference value.

STEP 2

The SAR distribution at the exposed side of the head was measured at a distance of 3.9mm from the inner surface of the shell. The area covered the entire dimension of the head and the horizontal grid spacing was 20mm x 20mm. Based on the area scan data, the area of the maximum absorption was determined by spline interpolation.

STEP 3

Around this point, a volume of 32mm x 32mm x 30mm (fine resolution volume scan, zoom scan) was assessed by measuring 5 x 5 x 7 points. On this basis of this data set, the spatial peak SAR value was evaluated with the following procedure:

The data at the surface was extrapolated, since the center of the dipoles is 2.7mm away from the tip of the probe and the distance between the surface and the lowest measuring point is 1.2mm. The extrapolation was based on a least square algorithm. A polynomial of the fourth order was calculated through the points in z-axes. This polynomial was then used to evaluate the points between the surface and the probe tip. The maximum interpolated value was searched with a straight-forward algorithm. Around this maximum the SAR values averaged over the spatial volumes (1g or 10g) were computed using the 3D-Spline interpolation algorithm. The 3D-spline is composed of three one-dimensional splines with the "Not a knot" condition (in x, y, and z directions). The volume was integrated with the trapezoidal algorithm. One thousand points (10 x 10 x 10) were interpolated to calculate the average. All neighboring volumes were evaluated until no neighboring volume with a higher average value was found.

STEP 4

The SAR value at the same location as in step 1 was again measured.

(If the value changed by more than 5%, the evaluation is repeated.)

FCC ID: A3LGTS3770Y	Report Number: FI-320-S1		Page :	12 of 35
 SAMSUNG Electronics CO. LTD	EUT Type:	850/1900 GSM/GPRS Phone with Bluetooth, WLAN and EDGE Rx only	Issue Date :	Jan.17, 2012

5. DESCRIPTION OF TEST POSITION

5.1 SAM Phantom Shape

Figure 5.1 shows the front, back and side views of SAM. The point “M” is the reference point for the center of mouth, “LE” is the left ear reference point (ERP), and “RE” is the right ERP. The ERPs are 15 mm posterior to the entrance to ear canal (EEC) along the B-M line (Back-Mouth), as shown in Figure 5.2.



Figure 5.1 Front, back and side view of SAM

The plane passing through the two ear canals and M is defined as the Reference Plane. The line N-F (Neck-Front) perpendicular to the reference plane and passing through the RE (or LE) is called the Reference Pivoting Line (see Figure 5.3). Line B-M is perpendicular to the N-F line. Both N-F and B-M lines should be marked on the external phantom shell to facilitate handset positioning. Posterior to the N-F line, the thickness of the phantom shell with the shape of an ear is a flat surface 6 mm thick at the ERPs.

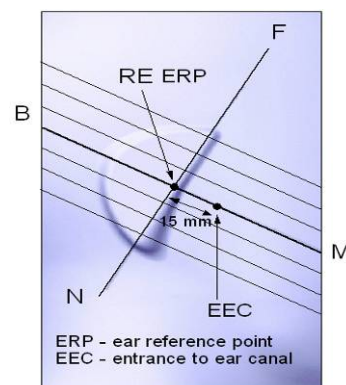



Figure 5.2 Close up side view

5.2 “cheek” Position

Two imaginary lines on the handset were established: the vertical centerline and the horizontal line. The test device was placed in a normal operating position with the “test device reference point” located along the “vertical centerline” on the front of the device aligned to the “ear reference point” (see Fig. 5.4). The “test device reference point” was then located at the same level as the center of the ear reference point. The test device was positioned so that the “vertical centerline” was bisecting the front surface of the handset at its tip and bottom edges, positioning the “ear reference point” on the outer surface of the both the left and right head phantoms on the ear reference point

FCC ID: A3LGTS3770Y	Report Number: FI-320-S1		Page :	13 of 35
 SAMSUNG Electronics CO. LTD	EUT Type:	850/1900 GSM/GPRS Phone with Bluetooth, WLAN and EDGE Rx only	Issue Date :	Jan.17, 2012

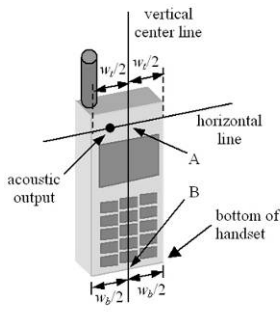

Figure 5.4 Handset vertical and horizontal reference lines

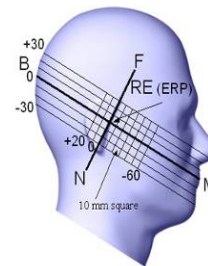
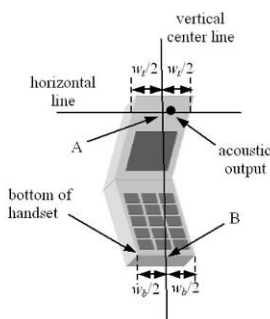

Figure 5.3 Side view of the phantom showing relevant markings

Step 1

The test device was positioned with the handset close to the surface of the phantom such that point A is on the (virtual) extension of the line passing through points RE and LE on the phantom (see Figure 5.5), such that the plane defined by the vertical center line and the horizontal line of the phone is approximately parallel to the sagittal plane of the phantom

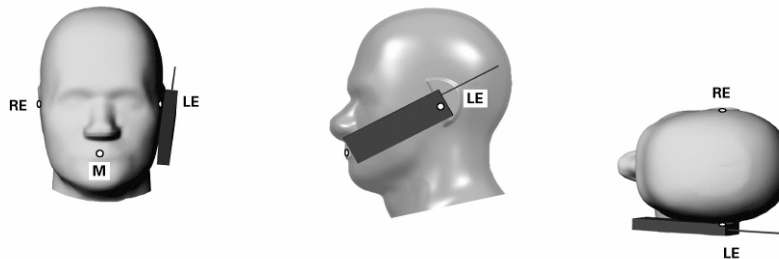

Figure 5.5 Front, Side and Top View of Cheek/Touch Position

Step 2

The handset was translated towards the phantom along the line passing through RE & LE until the handset touches the ear.

Step 3

While maintaining the handset in this plane, the handset was rotated around the LE-RE line until the vertical centerline was in the plane normal to MB-NF including the line MB (reference plane).

Step 4

Rotate the handset around the vertical centerline until the phone (horizontal line) was symmetrical with respect to the line NF.

FCC ID: A3LGTS3770Y	Report Number: FI-320-S1		Page :	14 of 35
 SAMSUNG Electronics CO. LTD	EUT Type:	850/1900 GSM/GPRS Phone with Bluetooth, WLAN and EDGE Rx only	Issue Date :	Jan.17, 2012

Step 5

While maintaining the vertical centerline in the reference plane, keeping point A on the line passing through RE and LE, and maintaining the phone contact with the ear, the handset was rotated about the line NF until any point on the handset made contact with a phantom point below the ear (cheek). See Figure 5.2.

5.3 “tilted” Position

With the test device aligned in the “cheek” position :

Step 1

Repeat steps 1 to 5 of 5.2 to place the device in the “Cheek/Touch Position”

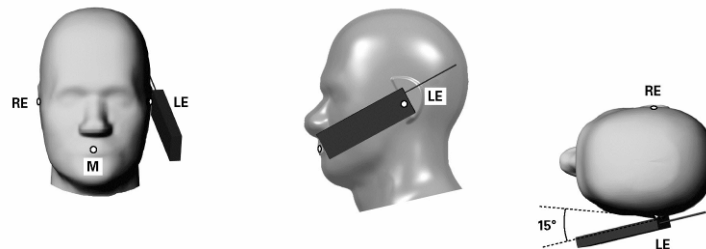

Figure 5.6 Front, side and Top View of Ear/Tilt 15° Position

Step 2

While maintaining the orientation of the phone, the phone was retracted parallel to the reference plane far enough to enable a rotation of the phone by 15 degree.

Step 3

The phone was then rotated around the horizontal line by 15 degree.

Step 4

While maintaining the orientation of the phone, the phone was moved parallel to the reference plane until any part of the phone touches the head. (In this position, point A was located on the line RE-LE). The tilted position is obtained when the contact is on the pinna. If the contact was at any location other than the pinna, the angle of the phone would then be reduced. The tilted position was obtained when any part of the phone was in contact of the ear as well as a second part of the phone was in contact with the head.

FCC ID: A3LGTS3770Y	Report Number: FI-320-S1		Page :	15 of 35
 SAMSUNG Electronics CO. LTD	EUT Type:	850/1900 GSM/GPRS Phone with Bluetooth, WLAN and EDGE Rx only	Issue Date :	Jan.17, 2012

5.4 Body Holster/Belt Clip Configurations

Body-worn operating configurations are tested with the belt-clips and holsters attached to the device and positioned against a flat phantom in a normal use configuration (see Figure 5.7). A device with a headset output is tested with a headset connected to the device. Body dielectric parameters are used.



Figure 5.7 Body Belt Clip and Holster Configurations

Accessories for Body-worn operation configurations are divided into two categories: those that do not contain metallic components and those that contain metallic components. When multiple accessories that do not contain metallic components are supplied with the device, the device is tested with only the accessory that dictates the closest spacing to the body. Then multiple accessories that contain metallic components are supplied with the device, the device is tested with each accessory that contains unique metallic component. If multiple accessory share an identical metallic component (i.e. the same metallic belt-clip used with different holsters with no other metallic components) only the accessory that dictates the closest spacing to the body is tested.

Body-worn accessories may not always be supplied or available as options for some Devices intended to be authorized for body-worn use. In this case, a test configuration where a separation distance between the back of the device and the flat phantom is used.

Transmitters that are designed to operate in front of a person's face, as in push-to-talk configurations, are tested for SAR compliance with the front of the device positioned to face the flat phantom. For devices that are carried next to the body such as a shoulder, waist or chest-worn transmitters, SAR compliance is tested with the accessory(ies), Including headsets and microphones, attached to the device and positioned against a flat phantom in a normal use configuration.

FCC ID: A3LGTS3770Y	Report Number: FI-320-S1		Page :	16 of 35
 SAMSUNG Electronics CO. LTD	EUT Type:	850/1900 GSM/GPRS Phone with Bluetooth, WLAN and EDGE Rx only	Issue Date :	Jan.17, 2012

In all cases SAR measurements are performed to investigate the worst-case positioning. Worst-case positioning is then documented and used to perform Body SAR testing.

In order for users to be aware of the body-worn operating requirements for meeting RF exposure compliance, operating instructions and cautions statements must be included in the user's manual.

- End of page -

FCC ID: A3LGTS3770Y	Report Number: FI-320-S1		Page :	17 of 35
 SAMSUNG Electronics CO. LTD	EUT Type:	850/1900 GSM/GPRS Phone with Bluetooth, WLAN and EDGE Rx only	Issue Date :	Jan.17, 2012

6. MEASUREMENT UNCERTAINTY

Table 6.1 Uncertainty Budget at 835MHz

Error Description	Uncertainty Value (±%)	Probability Distribution	Divisor	c_i	Standard uncertainty (±%)	v_i^2 or v_{eff}
Measurement System						
Probe Calibration	11.00	normal	2.000	1	5.50	∞
Axial Isotropy	4.70	rectangular	1.732	0.7	1.90	∞
Hemispherical Isotropy	9.60	rectangular	1.732	0.7	3.88	∞
Linearity	4.70	rectangular	1.732	1	2.71	∞
System Detection Limits	0.25	rectangular	1.732	1	0.14	∞
Boundary effects	1.00	rectangular	1.732	1	0.58	∞
Readout electronics	0.30	normal	1.000	1	0.30	∞
Response time	0.80	rectangular	1.732	1	0.46	∞
RF ambient conditions	3.00	rectangular	1.732	1	1.73	∞
Integration time	1.73	rectangular	1.732	1	1.00	∞
Mechanical constrains of robot	1.50	rectangular	1.732	1	0.87	∞
Probe positioning	2.90	rectangular	1.732	1	1.67	∞
Extrapolation and integration	1.00	rectangular	1.732	1	0.58	∞
Test Sample Related						
Test Sample positioning	1.12	normal	1.000	1	1.12	14
Device holded uncertainty	3.44	normal	1.000	1	3.44	∞
Power Drift	5.00	rectangular	1.732	1	2.89	∞
Phantom and Setup						
Modular Phantom uncertainty	5.62	normal	1.000	1	5.62	2
Phantom uncertainty	4.00	rectangular	1.732	1	2.31	∞
Liquid conductivity (deviation from target)	5.00	rectangular	1.732	0.64	1.85	∞
Liquid conductivity (measurement error)	0.38	normal	1.000	0.64	0.24	∞
Liquid permittivity (deviation from target)	5.00	rectangular	1.732	0.6	1.73	∞
Liquid permittivity (measurement error)	5.44	normal	1.000	0.6	3.26	∞
Combined Standard Uncertainty		Normal	-	-	11.84	172776
Extended Standard Uncertainty(K=2.00)					23.69	172776

FCC ID: A3LGTS3770Y	Report Number: FI-320-S1		Page :	18 of 35
 SAMSUNG Electronics CO. LTD	EUT Type:	850/1900 GSM/GPRS Phone with Bluetooth, WLAN and EDGE Rx only	Issue Date :	Jan.17, 2012

Table 6.2 Uncertainty Budget at 1900MHz

Error Description	Uncertainty Value (±%)	Probability Distribution	Divisor	c_i	Standard uncertainty (±%)	v_i^2 or v_{eff}
Measurement System						
Probe Calibration	11.00	normal	2.000	1	5.50	∞
Axial Isotropy	4.70	rectangular	1.732	0.7	1.90	∞
Hemispherical Isotropy	9.60	rectangular	1.732	0.7	3.88	∞
Linearity	4.70	rectangular	1.732	1	2.71	∞
System Detection Limits	0.25	rectangular	1.732	1	0.14	∞
Boundary effects	1.00	rectangular	1.732	1	0.58	∞
Readout electronics	0.30	normal	1.000	1	0.30	∞
Response time	0.80	rectangular	1.732	1	0.46	∞
RF ambient conditions	3.00	rectangular	1.732	1	1.73	∞
Integration time	0.00	rectangular	1.732	1	0.00	∞
Mechanical constrains of robot	1.50	rectangular	1.732	1	0.87	∞
Probe positioning	2.90	rectangular	1.732	1	1.67	∞
Extrapolation and integration	1.00	rectangular	1.732	1	0.58	∞
Test Sample Related						
Test Sample positioning	1.50	normal	1.000	1	1.50	14
Device holded uncertainty	3.44	normal	1.000	1	3.44	∞
Power Drift	5.00	rectangular	1.732	1	2.89	∞
Phantom and Setup						
Modular Phantom uncertainty	6.02	normal	1.000	1	6.02	2
Phantom uncertainty	4.00	rectangular	1.732	1	2.31	∞
Liquid conductivity (deviation from target)	5.00	rectangular	1.732	0.64	1.85	∞
Liquid conductivity (measurement error)	1.84	normal	1.000	0.64	1.18	∞
Liquid permittivity (deviation from target)	5.00	rectangular	1.732	0.6	1.73	∞
Liquid permittivity (measurement error)	4.54	normal	1.000	0.6	2.73	∞
Combined Standard Uncertainty		Normal	-	-	12.00	60176
Extended Standard Uncertainty(K=2.00)					24.00	60176



FCC ID: A3LGTS3770Y	Report Number: FI-320-S1		Page :	19 of 35
 SAMSUNG Electronics CO. LTD	EUT Type:	850/1900 GSM/GPRS Phone with Bluetooth, WLAN and EDGE Rx only	Issue Date :	Jan.17, 2012

Table 6.3 Uncertainty Budget at 2450MHz

Error Description	Uncertainty Value (±%)	Probability Distribution	Divisor	C _i	Standard uncertainty (±%)	v _i ² or v _{eff}
Measurement System						
Probe Calibration	11.00	normal	2.000	1	5.00	∞
Axial Isotropy	4.70	rectangular	1.732	0.7	1.90	∞
Hemispherical Isotropy	9.60	rectangular	1.732	0.7	3.88	∞
Linearity	4.70	rectangular	1.732	1	2.71	∞
System Detection Limits	0.25	rectangular	1.732	1	0.14	∞
Boundary effects	1.00	rectangular	1.732	1	0.58	∞
Readout electronics	0.30	normal	1.000	1	0.30	∞
Response time	0.80	rectangular	1.732	1	0.46	∞
RF ambient conditions	3.00	rectangular	1.732	1	1.73	∞
Integration time	0.00	rectangular	1.732	1	0.00	∞
Mechanical constrains of robot	1.50	rectangular	1.732	1	0.87	∞
Probe positioning	2.90	rectangular	1.732	1	1.67	∞
Extrapolation and integration	1.00	rectangular	1.732	1	0.58	∞
Test Sample Related						
Test Sample positioning	4.22	normal	1.000	1	4.22	14
Device holded uncertainty	3.44	normal	1.000	1	3.44	∞
Power Drift	5.00	rectangular	1.732	1	2.89	∞
Phantom and Setup						
Modular Phantom uncertainty	2.32	Normal	1.0001	1	2.32	2
Phantom uncertainty	4.00	rectangular	1.732	1	2.31	∞
Liquid conductivity (deviation from target)	5.00	rectangular	1.732	0.64	1.85	∞
Liquid conductivity (measurement error)	2.04	normal	1.000	0.64	1.30	∞
Liquid permittivity (deviation from target)	5.00	rectangular	1.732	0.6	1.73	∞
Liquid permittivity (measurement error)	4.27	normal	1.000	0.6	2.56	∞
Combined Standard Uncertainty		Normal	-	-	11.32	728
Extended Standard Uncertainty(K=2.00)					22.64	728

FCC ID: A3LGTS3770Y	Report Number: FI-320-S1		Page :	20 of 35
 SAMSUNG Electronics CO. LTD	EUT Type:	850/1900 GSM/GPRS Phone with Bluetooth, WLAN and EDGE Rx only	Issue Date :	Jan.17, 2012

7. SYSTEM VERIFICATION

7.1 Tissue Verification

Table 7.1 MEASURED TISSUE PARAMETERS

	835MHz Head		835MHz Body		1900MHz Head		1900MHz Body		2450MHz Head		2450MHz Body	
	Target	Measured	Target	Measured	Target	Measured	Target	Measured	Target	Measured	Target	Measured
Date	Jan.13,2012		Jan.13,2012		Jan.12,2012		Jan.12,2012		Jan.13,2012		Jan.13,2012	
Liquid Temperature(°C)	22.6		22.5		22.8		22.8		22.6		22.6	
Dielectric Constant: \hat{a}'	41.5	42.4	55.2	54.3	40	38.8	53.3	52.6	39.2	38.6	52.7	51.5
Conductivity:	0.9	0.92	0.97	0.98	1.4	1.4	1.52	1.54	1.8	1.85	1.95	1.95
Tissue Batch Number	835DF2001M		835B2001M		1900F2001U		1900B2002J		2450MF2001C		2450B2001C	

The measured value must be within $\pm 5\%$ of the target value.

7.2 Test System Validation

Prior to assessment, the system is verified to the $\pm 10\%$ of the specification at 835MHz, 1900MHz and 2450MHz by using the system validation kit(s). (see Appendix D, Graphic Plot Attached)

Table 7.2 System Validation Results

System Validation Kit	Tissue	Targeted SAR _{1g} (mW/g)	Measured SAR _{1g} (mW/g)	Normalized SAR _{1g} (mW/g)	Deviation (%)	Date	Liquid Temperature(°C)	Ambient Temperature(°C)	Input Power (mW)
4d050	835MHz Brain	9.61	0.975	9.75	1.46	Jan. 13, 2012	22.6	22.8	100
4d050	835MHz Body	10	1.04	10.4	4.00	Jan. 13, 2012	22.5	22.7	100
5d082	1900MHz Brain	41.4	4.17	41.7	0.72	Jan. 12, 2012	22.8	23.0	100
5d082	1900MHz Body	40.7	3.98	39.8	-2.21	Jan. 12, 2012	22.8	23.0	100
708	2450MHz Brain	55.8	5.64	56.4	1.08	Jan. 13, 2012	22.6	22.7	100
708	2450MHz Body	51.2	4.76	47.6	-7.03	Jan. 13, 2012	22.6	22.7	100

*Validation was measured with input power 100 mW, and normalized to 1W.

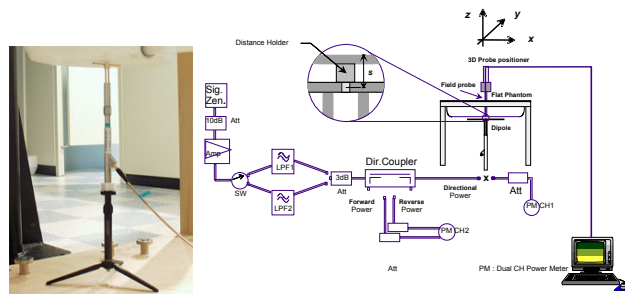



Figure 7.1 Dipole Validation Test Setup

FCC ID: A3LGT53770Y	Report Number: FI-320-S1		Page :	21 of 35
 SAMSUNG Electronics CO. LTD	EUT Type:	850/1900 GSM/GPRS Phone with Bluetooth, WLAN and EDGE Rx only	Issue Date :	Jan.17, 2012

8. SAR MEASUREMENT RESULTS

Procedures Used To Establish Test Signal

The handset was placed into simulated call mode using base station simulator. Such test signals offer a consistent means for testing SAR and are recommended for evaluating SAR. When test modes are not available or inappropriate for testing a handset, the actual transmission is activated through a base station simulator or similar equipment. See data pages for actual procedure used in measurement.

Device Test Conditions

The handset is battery operated. Each SAR measurement was taken with a fully charged battery. In order to verify that the device was tested at full power, conducted output power measurements were performed before and after each SAR measurement to confirm the output power. If a conducted power deviation of more than 5% occurred, the test was repeated. And all Tx(1~4Tx) conducted power were also investigated for Body-Worn SAR Measurement

Table 8.2 GPRS Power Table for GT-S3770Y

Band	Channel	Voice	1Tx	2Tx	3Tx	4Tx
850 (dBm)	128	32.22	32.22	30.94	30.04	28.66
	190	32.21	32.21	30.86	29.94	28.57
	251	32.29	32.29	31.19	29.91	28.54
1900 (dBm)	512	29.32	29.32	27.58	25.6	23.96
	661	28.93	28.93	27.17	25.62	23.92
	810	29	29	27.27	26.03	24.53

Table 8.3 Calculated Frame-Averaged Output Power Table for GT-S3770Y

Band	Channel	Voice	1Tx	2Tx	3Tx	4Tx
850 (dBm)	128	23.19	23.19	24.92	25.78	25.65
	190	23.18	23.18	24.84	25.68	25.56
	251	23.26	23.26	25.17	25.65	25.53
1900 (dBm)	512	20.29	20.29	21.56	21.34	20.95
	661	19.90	19.90	21.15	21.36	20.91
	810	19.97	19.97	21.25	21.77	21.52

FCC ID: A3LGTS3770Y	Report Number: FI-320-S1		Page :	22 of 35
 SAMSUNG Electronics CO. LTD	EUT Type:	850/1900 GSM/GPRS Phone with Bluetooth, WLAN and EDGE Rx only	Issue Date :	Jan.17, 2012

Note:

Both burst-averaged and calculated frame-averaged powers are included. The bolded GPRS modes were selected according to the highest frame-averaged output power table per KDB Publication 941225 D03.

The GSM conducted powers are reported and measured by base station simulator E5515C.

GPRS(GMSK) output powers were measured with CS1.

GSM Class : B

GPRS Multislot Class : 12 (max 4 Tx Uplink slots)

EDGE Multislot class: EDGE Rx Only

DTM Multislot Class : N/A

*The calculated frame averaged output powers are derived from GPRS power table with time averaging. To average output power, subtract $10 \cdot \log(\text{Num of Tx slot})$ from GPRS power.

- End of Page -

FCC ID: A3LGTS3770Y	Report Number: FI-320-S1		Page :	23 of 35
 SAMSUNG Electronics CO. LTD	EUT Type:	850/1900 GSM/GPRS Phone with Bluetooth, WLAN and EDGE Rx only	Issue Date :	Jan.17, 2012

Table 8.4 802.11b and g Average RF Power

Mode	Channel Frequency (MHz)	Channel	Data rate (Mbps)	Attenuator + Cable offset (dB)	Average power Result (dBm)	Peak Power Result (dBm)
DSSS (802.11b)	2 412	Low	1	21.99	16.96	<u>19.42</u>
			2		16.81	19.40
			5.5		16.55	19.29
			11		16.14	19.39
	2 437	Middle	1		16.35	<u>19.45</u>
			2		16.24	18.84
			5.5		15.92	18.92
			11		15.53	19.05
	2 462	High	1		16.80	<u>19.35</u>
			2		16.74	19.32
			5.5		16.39	19.34
			11		15.97	19.33
OFDM (802.11g)	2 412	Low	6	14.32	<u>22.68</u>	
			9	14.01	22.18	
			12	13.64	22.25	
			18	13.19	22.22	
			24	12.73	22.63	
			36	11.94	22.52	
			48	11.39	22.65	
			54	10.63	22.61	
	2 437	Middle	6	13.74	<u>22.68</u>	
			9	13.39	21.80	
			12	13.05	22.13	
			18	12.57	22.06	
			24	12.06	22.29	
			36	11.24	22.17	
			48	10.71	22.62	
			54	10.01	22.35	
	2 462	High	6	14.32	<u>22.68</u>	
			9	13.98	22.18	
			12	13.71	22.65	
			18	13.20	22.56	
			24	12.76	22.65	
			36	11.94	22.56	
			48	11.39	22.61	
			54	10.65	22.64	

Simultaneous Transmission

Refer to the FCC OET document, 'SAR Evaluation Considerations for Handsets with Multiple Transmitters and Antennas' (Feb 2008)

Table 8.6 Output Power Thresholds for Unlicensed Transmitters

	2.45	5.15 - 5.35	5.47 - 5.85	GHz
P Ref	12	6	5	mW
Device output power should be rounded to the nearest mW to compare with values specified in this table				

Table 8.7 Summary of SAR Evaluation Requirements for Cell phones with Multiple Transmitters

	Individual Transmitter	Simultaneous Transmission
Licensed Transmitters	<u>Routine evaluation required</u>	SAR not required: <u>Unlicensed only</u> o when stand-alone 1-g SAR is not required and antenna is > 5 cm from other antennas
Unlicensed Transmitters	<p>When there is no simultaneous transmission –</p> <ul style="list-style-type: none"> o output < 60/f: SAR not required o output ≥ 60/f: stand-alone SAR required <p>When there is simultaneous transmission –</p> <p><u>Stand-alone SAR not required when</u></p> <ul style="list-style-type: none"> o output ≤ 2.P_{Ref} and antenna is > 5.0 cm from other antennas o output ≤ P_{Ref} and antenna is ≥ 2.5 cm from other antennas o output ≤ P_{Ref} and antenna is < 2.5 cm from other antennas, each with either output power ≤ P_{Ref} or 1-g SAR < 1.2 W/kg <p><u>Otherwise stand-alone SAR is required</u></p> <p>When stand-alone SAR is required</p> <ul style="list-style-type: none"> o test SAR on highest output channel for each wireless mode and exposure condition o if SAR for highest output channel is > 50% of SAR limit, evaluate all channels according to normal procedures 	<p><u>Licensed & Unlicensed</u></p> <ul style="list-style-type: none"> o when the sum of the 1-g SAR is <1.6 W/kg for all simultaneous transmitting antennas o when SAR to antenna separation ratio of simultaneous transmitting antenna pair is < 0.3 <p>SAR required:</p> <p><u>Licensed & Unlicensed</u></p> <p>antenna pairs with SAR to antenna separation ratio ≥ 0.3; test is only required for the configuration that results in the highest SAR in standalone configuration for each wireless mode and exposure condition</p> <p>Note: simultaneous transmission exposure conditions for head and body can be different for different style phones; therefore, different test requirements may apply</p>

FCC ID: A3LGT3770Y	Report Number: FI-320-S1		Page :	25 of 35
 SAMSUNG Electronics CO. LTD	EUT Type:	850/1900 GSM/GPRS Phone with Bluetooth, WLAN and EDGE Rx only	Issue Date :	Jan.17, 2012

Table 8.8 Simultaneous Transmission Summation for Held to Ear Voice Call

Simult Tx	Configuration	GSM850 SAR(W/Kg)	WIFI SAR (W/Kg)	Σ SAR (W/Kg)	Simult Tx	Configuration	GSM1900 SAR(W/Kg)	WIFI SAR (W/Kg)	Σ SAR (W/Kg)
Head SAR	Right Cheek	0.405	0.21	0.615	Head SAR	Right Cheek	0.755	0.21	0.965
	Right Tilt	0.216	0.182	0.398		Right Tilt	0.253	0.182	0.435
	Left Cheek	0.499	0.182	0.681		Left Cheek	0.728	0.182	0.91
	Left Tilt	0.2	0.206	0.406		Left Tilt	0.231	0.206	0.437

Table 8.9 Simultaneous Transmission Summation for 2G Data and WIFI(Body-Worn)

Configuration	Mode	2G SAR (W/Kg)	WIFI SAR (W/Kg)	Σ SAR (W/Kg)
Back	GPRS850 SAR(W/Kg)	0.393	0.08	0.473
	GPRS1900 SAR(W/Kg)	0.405	0.08	0.485

Multiple Antenna/Transmission Information for GT-S3770Y

The separation between the main antenna and the Bluetooth antennas is 70.84 mm.

RF Conducted Power of Bluetooth Tx is 7.02 dBm.

RF Conducted Power of WLAN Tx is 16.96 dBm

Conclusion

Based on the output power, antenna separation distance, and Body SAR, a stand-alone BT SAR test is not required. The summation of BT SAR and Licensed Transmitter SAR is 0.405 + 0 = 0.524, which is less than 1.6 W/Kg, therefore, a simultaneous SAR evaluation is not required.

- End of page -

FCC ID: A3LGTS3770Y	Report Number: FI-320-S1		Page :	26 of 35
 SAMSUNG Electronics CO. LTD	EUT Type:	850/1900 GSM/GPRS Phone with Bluetooth, WLAN and EDGE Rx only	Issue Date :	Jan.17, 2012

8.1 GSM850 Head SAR Results

Frequency		Mode	Conducted		Side	Test Position	Antenna Type	Battery	Drift (dB)	SAR Level (W/kg)
MHz	Ch		Start	End						
836.6	190	GSM850	32.21	32.22	Right	Cheek/Touch	Intenna	Standard	-0.057	0.405
836.6	190	GSM850	32.24	32.21	Right	Ear/Tilt 15°	Intenna	Standard	0.015	0.216
836.6	190	GSM850	32.20	32.19	Left	Cheek/Touch	Intenna	Standard	0.024	0.499
836.6	190	GSM850	32.18	32.22	Left	Ear/Tilt 15°	Intenna	Standard	-0.052	0.200
ANSI / IEEE C95.1 1992 – SAFETY LIMIT Spatial Peak Uncontrolled Exposure / General Population						1.6W/kg (mW/g) averaged over 1 gram				

NOTES:

1. The test data reported are the worst-case SAR value with the position set in a typical configuration. Test procedures used are according to FCC/OET Bulletin 65, Supp.C [June 2001].
2. Tissue parameters and temperatures are listed on the SAR plot.
3. Liquid tissue depth is 15.2 ± 0.2 cm
4. Battery is fully charged for all readings.
5. Test Configuration Manu. Test Codes Base Station Simulator
6. Justification for reduced test configurations: Per FCC/OET Bulletin 65 Supplement C (June, 2001), if the SAR measured at the middle channel for each test configuration (left, right, cheek/touch, tilt/ear, extended and retracted) is least 3.0 dB lower than the SAR limit, testing at the high and low channels is optional for such test configuration(s).

FCC ID: A3LGTS3770Y	Report Number: FI-320-S1		Page :	27 of 35
 SAMSUNG Electronics CO. LTD	EUT Type:	850/1900 GSM/GPRS Phone with Bluetooth, WLAN and EDGE Rx only	Issue Date :	Jan.17, 2012

8.2 GPRS850 Body SAR Results(Without Holster)

Frequency		Mode	Conducted		Separation Distance	Test Position	Antenna Type	Battery	Tx GPRS Slots	Drift (dB)	SAR Level (W/kg)
MHz	Ch		Start	End							
836.6	190	GPRS850	30.86	30.88	1.5 cm [w/o Holster]	Back	Intenna	Standard	2	-0.089	0.333
836.6	190	GPRS850	29.95	29.94	1.5 cm [w/o Holster]	Back	Intenna	Standard	3	-0.078	0.393
836.6	190	GPRS850	28.55	28.56	1.5 cm [w/o Holster]	Back	Intenna	Standard	4	-0.072	0.379
ANSI / IEEE C95.1 1992 – SAFETY LIMIT Spatial Peak Uncontrolled Exposure / General Population							1.6W/kg (mW/g) averaged over 1 gram				

NOTES:

- The test data reported are the worst-case SAR value with the position set in a typical configuration. Test procedures used are according to FCC/OET Bulletin 65, Supp.C [June 2001].
- Tissue parameters and temperatures are listed on the SAR plot.
- Liquid tissue depth is 15.2 ± 0.2 cm
- Battery is fully charged for all readings.
- Test Configuration With Holster Without Holster
- Justification for reduced test configurations: This model supports GPRS CLASS "12" (4Tx) So the burst power and timing period is more than 2dB higher in GPRS mode than in GSM850 mode. Hence, the GSM850 mode was not measured.
- Justification for reduced test configurations: Per FCC/OET Bulletin 65 Supplement C (June, 2001), if the SAR measured at the middle channel for each test configuration (left, right, cheek/touch, tilt/ear, extended and retracted) is least 3.0 dB lower than the SAR limit, testing at the high and low channels is optional for such test configuration(s).
- Device was tested using a fixed spacing; a separation distance of 15 mm is chosen because Grantee has determined that it supports the types of body-worn accessories available in the marketplace to users for this handset.

FCC ID: A3LGTS3770Y	Report Number: FI-320-S1		Page :	28 of 35
 SAMSUNG Electronics CO. LTD	EUT Type:	850/1900 GSM/GPRS Phone with Bluetooth, WLAN and EDGE Rx only	Issue Date :	Jan.17, 2012

8.3 GSM1900 Head SAR Results

Frequency		Mode	Conducted		Side	Test Position	Antenna Type	Battery	Drift (dB)	SAR Level (W/kg)
MHz	Ch		Start	End						
1880	661	GSM1900	28.94	28.91	Right	Cheek/Touch	Intenna	Standard	0.078	0.755
1880	661	GSM1900	28.98	28.95	Right	Ear/Tilt 15°	Intenna	Standard	0.138	0.253
1880	661	GSM1900	28.92	28.95	Left	Cheek/Touch	Intenna	Standard	0.167	0.728
1880	661	GSM1900	28.98	28.92	Left	Ear/Tilt 15°	Intenna	Standard	0.016	0.231
ANSI / IEEE C95.1 1992 – SAFETY LIMIT Spatial Peak Uncontrolled Exposure / General Population						1.6W/kg (mW/g) averaged over 1 gram				

NOTES:

1. The test data reported are the worst-case SAR value with the position set in a typical configuration. Test procedures used are according to FCC/OET Bulletin 65, Supp.C [June 2001].
2. Tissue parameters and temperatures are listed on the SAR plot.
3. Liquid tissue depth is 15.2 ± 0.2cm
4. Battery is fully charged for all readings.
5. Test Configuration Manu. Test Codes Base Station Simulator
6. Justification for reduced test configurations: Per FCC/OET Bulletin 65 Supplement C (June, 2001), if the SAR measured at the middle channel for each test configuration (left, right, cheek/touch, tilt/ear, extended and retracted) is least 3.0 dB lower than the SAR limit, testing at the high and low channels is optional for such test configuration(s).

FCC ID: A3LGTS3770Y	Report Number: FI-320-S1		Page :	29 of 35
 SAMSUNG Electronics CO. LTD	EUT Type:	850/1900 GSM/GPRS Phone with Bluetooth, WLAN and EDGE Rx only	Issue Date :	Jan.17, 2012

8.4 GPRS1900 Body SAR Results(Without Holster)

Frequency		Mode	Conducted		Separation Distance	Test Position	Antenna Type	Battery	Tx GPRS Slots	Drift (dB)	SAR Level (W/kg)
MHz	Ch		Start	End							
1880	661	GPRS1900	27.18	27.16	1.5 cm [w/o Holster]	Back	Intenna	Standard	2	0.164	0.392
1880	661	GPRS1900	25.64	25.66	1.5 cm [w/o Holster]	Back	Intenna	Standard	3	0.100	0.405
1880	661	GPRS1900	23.94	23.91	1.5 cm [w/o Holster]	Back	Intenna	Standard	4	-0.032	0.356
ANSI / IEEE C95.1 1992 – SAFETY LIMIT Spatial Peak Uncontrolled Exposure / General Population						1.6W/kg (mW/g) averaged over 1 gram					

NOTES:

- The test data reported are the worst-case SAR value with the position set in a typical configuration. Test procedures used are according to FCC/OET Bulletin 65, Supp.C [June 2001].
- Tissue parameters and temperatures are listed on the SAR plot.
- Liquid tissue depth is 15.2 ± 0.2cm
- Battery is fully charged for all readings.
- Test Configuration With Holster Without Holster
- Justification for reduced test configurations: This model supports GPRS CLASS "12" (4Tx) So the burst power and timing period is more than 2dB higher in GPRS mode than in GSM1900 mode. Hence, the GSM1900 mode was not measured.
- Justification for reduced test configurations: Per FCC/OET Bulletin 65 Supplement C (June, 2001), if the SAR measured at the middle channel for each test configuration (left, right, cheek/touch, tilt/ear, extended and retracted) is least 3.0 dB lower than the SAR limit, testing at the high and low channels is optional for such test configuration(s).
- Device was tested using a fixed spacing; a separation distance of 15 mm is chosen because Grantee has determined that it supports the types of body-worn accessories available in the marketplace to users for this handset.

FCC ID: A3LGTS3770Y	Report Number: FI-320-S1		Page :	30 of 35
 SAMSUNG Electronics CO. LTD	EUT Type:	850/1900 GSM/GPRS Phone with Bluetooth, WLAN and EDGE Rx only	Issue Date :	Jan.17, 2012

8.5 WLAN Head SAR Results

Frequency		Mode	Conducted		Side	Test Position	Antenna Type	Battery	Data Rate (Mbps)	Drift (dB)	SAR Level (W/kg)
MHz	Ch		Start	End							
2412	1	IEEE 802.11b	16.98	16.97	Right	Cheek/Touch	Intenna	Standard	1	0.175	0.210
2412	1	IEEE 802.11b	16.94	16.91	Right	Ear/Tilt 15°	Intenna	Standard	1	-0.174	0.182
2412	1	IEEE 802.11b	16.92	16.92	Left	Cheek/Touch	Intenna	Standard	1	-0.004	0.182
2412	1	IEEE 802.11b	16.91	16.97	Left	Ear/Tilt 15°	Intenna	Standard	1	0.035	0.206
ANSI / IEEE C95.1 1992 – SAFETY LIMIT Spatial Peak Uncontrolled Exposure / General Population						1.6W/kg (mW/g) averaged over 1 gram					

NOTES:

- The test data reported are the worst-case SAR value with the position set in a typical configuration. Test procedures used are according to FCC/OET Bulletin 65, Supp.C [June 2001].
- Tissue parameters and temperatures are listed on the SAR plot.
- Liquid tissue depth is 15.2 ± 0.2 cm
- Battery is fully charged for all readings.
- Test Configuration Manu. Test Codes Base Station Simulator
- Justification for reduced test configurations for WIFI channels per KDB Publication 248227 and April 2010 FCC/TCB Meeting Notes for 2.4 GHz WIFI: Highest average RF output power channel for the lowest data rate were selected for SAR evaluation. Other IEEE 802.11 modes (including 802.11g) were not investigated since the average output powers were not greater than 0.25dB than that of the corresponding channel in the lowest data rate IEEE 802.11b mode.
- WLAN Transmission was verified using a spectrum analyzer.

FCC ID: A3LGT3770Y	Report Number: FI-320-S1		Page :	31 of 35
 SAMSUNG Electronics CO. LTD	EUT Type:	850/1900 GSM/GPRS Phone with Bluetooth, WLAN and EDGE Rx only	Issue Date :	Jan.17, 2012

8.6 WLAN Body SAR Results(Without Holster)

Frequency		Mode	Conducted		Separation Distance	Antenna Type	Battery	Test position	Data Rate (Mbps)	Drift (dB)	SAR Level (W/kg)
MHz	Ch		Start	End							
2412	1	IEEE 802. 11b	16.98	16.99	1.5 mm cm [w/o Holster]	Intenna	Standard	Back	1	0.025	0.080
ANSI / IEEE C95.1 1992 – SAFETY LIMIT Spatial Peak Uncontrolled Exposure / General Population						1.6W/kg (mW/g) averaged over 1 gram					

NOTES:

- The test data reported are the worst-case SAR value with the position set in a typical configuration. Test procedures used are according to FCC/OET Bulletin 65, Supp.C [June 2001].
- Tissue parameters and temperatures are listed on the SAR plot.
- Liquid tissue depth is 15.2 ± 0.2 cm
- Battery is fully charged for all readings.
- Test Configuration With Holster Without Holster
- Justification for reduced test configurations for WIFI channels per KDB Publication 248227 and April 2010 FCC/TCB Meeting Notes for 2.4 GHz WIFI: Highest average RF output power channel for the lowest data rate were selected for SAR evaluation. Other IEEE 802.11 modes (including 802.11g) were not investigated since the average output powers were not greater than 0.25dB than that of the corresponding channel in the lowest data rate IEEE 802.11b mode.
- Device was tested using a fixed spacing; a separation distance of 15 mm is chosen because Grantee has determined that it supports the types of body-worn accessories available in the marketplace to users for this handset.
- WLAN Transmission was verified using a spectrum analyzer.

FCC ID: A3LGTS3770Y	Report Number: FI-320-S1		Page :	32 of 35
 SAMSUNG Electronics CO. LTD	EUT Type:	850/1900 GSM/GPRS Phone with Bluetooth, WLAN and EDGE Rx only	Issue Date :	Jan.17, 2012

9. CONCLUSION

The SAR measurement indicates that the EUT complies with the RF radiation exposure limits of the FCC. These measurements are taken to simulate the RF effects exposure under worst-case conditions. Precise laboratory measures were taken to assure repeatability of the tests. The test results and statements relate only to the item(s) tested.

Please note that the absorption and distribution of electromagnetic energy in the body are very complex phenomena that depend on the mass, shape, and size of the body, the orientation of the body with respect to the field vectors, and the electrical properties of both the body and the environment. Other variables that may play a substantial role in possible biological effects are those that characterize the environment (e.g. ambient temperature, air velocity, relative humidity, and body insulation) and those that characterize the individual (e.g. age, gender, activity level, debilitation, or disease). Because innumerable factors may interact to determine the specific biological outcome of an exposure to electromagnetic fields, any protection guide shall consider maximal amplification of biological effects as a result of field-body interactions, environmental conditions, and physiological variables.

The highest reported SAR values are as follows:

GSM850: Head: 0.499W/Kg : Body-worn: 0.393W/Kg

GSM1900: Head: 0.755W/Kg : Body-worn: 0.405W/Kg

WLAN: Head: 0.210W/Kg : Body-worn: 0.08W/Kg

Highest simultaneous transmission: Head: 0.965W/Kg : Body: 0.485W/Kg

FCC ID: A3LGTS3770Y	Report Number: FI-320-S1		Page :	33 of 35
 SAMSUNG Electronics CO. LTD	EUT Type:	850/1900 GSM/GPRS Phone with Bluetooth, WLAN and EDGE Rx only	Issue Date :	Jan.17, 2012

10. REFERENCES

- [1] Federal Communications Commission, ET Docket 93-62, Guidelines for Evaluating the Environmental Effects of Radiofrequency Radiation, Aug. 1996.
- [2] ANSI/IEEE C95.1-2005, American National Standard safety levels with respect to human exposure to radio frequency electromagnetic fields, 300kHz to 100GHz, New York: IEEE, 2006.
- [3] ANSI/IEEE C95.1-1992, American National Standard safety levels with respect to human exposure to radio frequency electromagnetic fields, 300kHz to 100GHz, New York: IEEE, Sept. 1992.
- [4] ANSI/IEEE C95.3-2002, IEEE Recommended Practice for the Measurement of Potentially Hazardous Electromagnetic Fields - RF and Microwave, New York: IEEE, December 2002.
- [5] Federal Communications Commission, OET Bulletin 65 (Edition 97-01), Supplement C (Edition 01-01), Evaluating Compliance with FCC Guidelines for Human Exposure to Radiofrequency Electromagnetic Fields, June 2001.
- [6] IEEE Standards Coordinating Committee 34 – IEEE Std. 1528-2003, Recommended Practice for Determining the Peak Spatial-Average Specific Absorption Rate (SAR) in the Human Body Due to Wireless Communications Devices.
- [7] NCRP, National Council on Radiation Protection and Measurements, Biological Effects and Exposure Criteria for RadioFrequency Electromagnetic Fields, NCRP Report No. 86, 1986. Reprinted Feb. 1995.
- [8] T. Schmid, O. Egger, N. Kuster, Automated E-field scanning system for dosimetric assessments, IEEE Transaction on Microwave Theory and Techniques, vol. 44, Jan. 1996, pp. 105-113.
- [9] K. Pokovic, T. Schmid, N. Kuster, Robust setup for precise calibration of E-field probes in tissue simulating liquids at mobile communications frequencies, ICECOM97, Oct. 1997, pp. 120-124.
- [10] K. Pokovic, T. Schmid, and N. Kuster, E-field Probe with improved isotropy in brain simulating liquids, Proceedings of the ELMAR, Zadar, Croatia, June 23-25, 1996, pp. 172-175.
- [11] Schmid & Partner Engineering AG, Application Note: Data Storage and Evaluation, June 1998, p2.
- [12] V. Hombach, K. Meier, M. Burkhardt, E. Kuhn, N. Kuster, The Dependence of EM Energy Absorption upon Human Head Modeling at 900 MHz, IEEE Transaction on Microwave Theory and Techniques, vol. 44 no. 10, Oct. 1996, pp. 1865-1873.
- [13] N. Kuster and Q. Balzano, Energy absorption mechanism by biological bodies in the near field of dipole antennas above 300MHz, IEEE Transaction on Vehicular Technology, vol. 41, no. 1, Feb. 1992, pp. 17-23.
- [14] G. Hartsgrrove, A. Kraszewski, A. Surowiec, Simulated Biological Materials for Electromagnetic Radiation Absorption Studies, University of Ottawa, Bioelectromagnetics, Canada: 1987, pp. 29-36.
- [15] Q. Balzano, O. Garay, T. Manning Jr., Electromagnetic Energy Exposure of Simulated Users of Portable Cellular Telephones, IEEE Transactions on Vehicular Technology, vol. 44, no.3, Aug. 1995.
- [16] W. Gander, Computermathematik, Birkhaeuser, Basel, 1992.
- [17] W.H. Press, S.A. Teukolsky, W.T. Vetterling, and B.P. Flannery, Numerical Receptions in C, The Art of Scientific Computing, Second edition, Cambridge University Press, 1992.
- [18] Federal Communications Commission, OET Bulletin 65, Evaluating Compliance with FCC Guidelines for Human

FCC ID: A3LGTS3770Y	Report Number: FI-320-S1		Page :	34 of 35
 SAMSUNG Electronics CO. LTD	EUT Type:	850/1900 GSM/GPRS Phone with Bluetooth, WLAN and EDGE Rx only	Issue Date :	Jan.17, 2012

- Exposure to Radiofrequency Electromagnetic Fields. Supplement C, Dec. 1997.
- [19] N. Kuster, R. Kastle, T. Schmid, Dosimetric evaluation of mobile communications equipment with known precision, IEEE Transaction on Communications, vol. E80-B, no. 5, May 1997, pp. 645-652.
- [20] CENELEC CLC/SC111B, European Prestandard (prENV 50166-2), Human Exposure to Electromagnetic Fields High-frequency: 10kHz-300GHz, Jan. 1995.
- [21] Prof. Dr. Niels Kuster, ETH, Eidgenössische Technische Hochschule Zürich, Dosimetric Evaluation of the Cellular Phone.
- [22] IEC 62209-1, Human exposure to radio frequency fields from hand-held and body-mounted wireless communication devices - Human models, instrumentation, and procedures - Part 1: Procedure to determine the specific absorption rate (SAR) for hand-held devices used in close proximity to the ear (frequency range of 300 MHz to 3 GHz), Feb. 2005.
- [23] Industry Canada RSS-102 Radio Frequency Exposure Compliance of Radiocommunication Apparatus (All Frequency Bands) Issue 4, March 2010.
- [24] Health Canada Safety Code 6 Limits of Human Exposure to Radio Frequency Electromagnetic Fields in the Frequency Range from 3 kHz – 300 GHz, 2009
- [25] FCC Public Notice DA-02-1438. Office of Engineering and Technology Announces a Transition Period for the Phantom Requirements of Supplement C to OET Bulletin 65, June 19, 2002
- [26] FCC SAR Measurement Procedures for 3G Devices KDB 941225
- [27] SAR Measurement procedures for IEEE 802.11a/b/g KDB 248227
- [28] FCC SAR Considerations for Handsets with Multiple Transmitters and Antennas, KDB 648474
- [29] FCC Application Note for SAR Probe Calibration and System Verification Consideration for Measurements at 150 MHz – 3 GHz, KDB 450824
- [30] FCC SAR Evaluation Considerations for Laptop Computers with Antennas Built-in on Display Screens, KDB 616217
- [31] FCC SAR Measurement Requirements for 3 – 6 GHz, KDB 865664
- [32] FCC Mobile Portable RF Exposure Procedure, KDB 447498
- [33] FCC SAR Procedures for Dongle Transmitters, KDB 447498
- [34] Anexo à Resolução No. 533, de 10 de Setembro de 2009.
- [35] FCC SAR Test Considerations for LTE Handsets and Data Modems, KDB Publication 941225
- [36] IEC 62209-2, Human exposure to radio frequency fields from hand-held and body-mounted wireless communication devices - Human models, instrumentation, and procedures - Part 2: Procedure to determine the specific absorption rate (SAR) for wireless communication devices used in close proximity to the human body (frequency range of 30 MHz to 6 GHz), Mar. 2010.
- [37] FCC Hot Spot SAR v01, KDB Publication 941225 D06.

FCC ID: A3LGTS3770Y	Report Number: FI-320-S1		Page :	35 of 35
 SAMSUNG Electronics CO. LTD	EUT Type:	850/1900 GSM/GPRS Phone with Bluetooth, WLAN and EDGE Rx only	Issue Date :	Jan.17, 2012

APPENDIX A

SAR Definition

Specific Absorption Rate (SAR) is defined as the time derivative (rate) of the incremental energy (dU) absorbed by (dissipated in) an incremental mass (dm) contained in a volume element (dV) of a given density (ρ). It is also defined as the rate of RF energy absorption per unit mass at a point in an absorbing body (see Fig. A.1) .

$$SAR = \frac{d}{dt} \left(\frac{dU}{dm} \right) = \frac{d}{dt} \left(\frac{dU}{\rho dv} \right)$$

Figure A.1 SAR Mathematical Equation

SAR is expressed in units of Watts per Kilogram (W/kg).

$$SAR = \sigma E^2 / \rho$$

Where :

- σ = conductivity of the tissue-simulant material (S/m)
- ρ = mass density of the tissue-simulant material (kg/m³)
- E = Total RMS electric field strength (V/m)

Note: The primary factors that control rate or energy absorption were found to be the wavelength of the incident field in relations to the dimensions and geometry of the irradiated organism, the orientation of the organism in relation to the polarity of field vectors, the presence of reflecting surfaces, and whether conductive contact is made by the organism with a ground plane.

APPENDIX B

Probe Calibration Process

Dosimetric Assessment Procedure

Each probe is calibrated according to a dosimetric assessment procedure described in **K. Pokovic, T.Schmid, N. Kuster, *Robust setup for precise calibration of E-field probes in tissue simulating liquids at mobile communications frequencies*, ICECOM97, Oct. 1997, pp. 120-124** with an accuracy better than +/-10%. The spherical isotropy was evaluated with the procedure described in **K. Pokovic, T.Schmid, N. Kuster, *E-field Probe with improved isotropy in brain simulating liquids*, Proceedings of the ELMAR, Zadar, June 23-25, 1996, pp. 172-175** and found to be better than +/-0.25dB. The sensitivity parameters (NormX, NormY, NormZ), the diode compression parameter (DCP) and the conversion factor (ConvF) of the probe is tested.

Free Space Assessment

The free space E-field from amplified probe outputs is determined in a test chamber. This is performed in a TEM cell for frequencies below 1 GHz (see Fig. B.1), and in a waveguide above 1 GHz for free space. For the free space calibration, the probe is placed in the volumetric center of the cavity and at the proper orientation with the field. The probe is then rotated 360 degrees.

Temperature Assessment

E-field temperature correlation calibration is performed in a flat phantom flat phantom filled with the appropriate simulated brain tissue. The measured free space E-field in the medium correlates to temperature rise in a dielectric medium. For temperature correlation calibration a RF transparent thermistor-based temperature probe is used in conjunction with the E-field probe (see Fig. B.2).

$$SAR = C \frac{\Delta T}{\Delta t}$$

$$SAR = \frac{|E|^2 \cdot \sigma}{\rho}$$

where:

Δt = exposure time (30 seconds)

C = heat capacity of tissue (brain or muscle).

ΔT = temperature increase due to RF exposure.

SAR is proportional to $\Delta T / \Delta t$, the initial rate of tissue heating, before thermal diffusion takes place. Now it's possible to quantify the electric field in the simulated tissue by equating the thermally derived SAR to the E-field;

where:

σ = simulated tissue conductivity

ρ = Tissue density (1.25 g/cm³ for brain tissue)

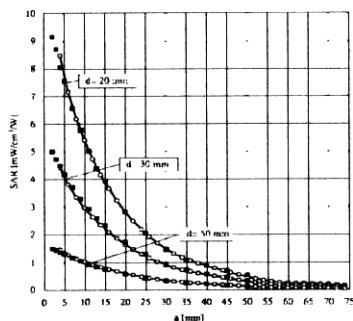

Figure B.1. E-Field and Temperature measurements at 900MHz

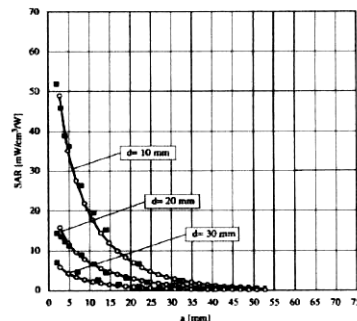

Figure B.2. E-Field and temperature measurements at 1.9GHz

APPENDIX C

ANSI/IEEE C95.1 – 2005 RF EXPOSURE LIMITS

Uncontrolled Environment

UNCONTROLLED ENVIRONMENTS are defined as locations where there is the exposure of individuals who have no knowledge or control of their exposure. The general population/uncontrolled exposure limits are applicable to situations in which the general public may be exposed or in which persons who are exposed as a consequence of their employment may not be made fully aware of the potential for exposure or cannot exercise control over their exposure. Members of the general public would come under this category when exposure is not employment-related; for example, in the case of a wireless transmitter that exposes persons in its vicinity.

Controlled Environment

CONTROLLED ENVIRONMENTS are defined as locations where there is the exposure that may be incurred by persons who are aware of the potential for exposure, (i.e. as a result of employment or occupation). In general, occupational/controlled exposure limits are applicable to situations in which persons are exposed as a consequence of their employment, who have been made fully aware of the potential for exposure and can exercise control over their exposure. This exposure category is also applicable when the exposure is of a transient nature due to incidental passage through a location where the exposure levels may be higher than the general population/uncontrolled limits, but the exposed person is fully aware of the potential for exposure and can exercise control over his or her exposure by leaving the area or by some other appropriate means.

Table C.1 Safety Limits for Partial Body Exposure

	UNCONTROLLED ENVIRONMENT General Population (W/kg) or (mW/g)	CONTROLLED ENVIRONMENT General Population (W/kg) or (mW/g)
SPATIAL PEAK SAR ¹ Brain	1.60	8.00
SPATIAL PEAK SAR ² Whole Body	0.08	0.40
SPATIAL PEAK SAR ³ Hands, Feet, Ankles, Wrists	4.00	20.00

¹ The Spatial Peak value of the SAR averaged over any 1 gram of tissue (defined as tissue volume in the shape of a cube) and over the appropriate averaging time.

² The Spatial Average value of the SAR averaged over the whole body.

³ The Spatial Peak value of the SAR averaged over any 10 grams of tissue (defined as a tissue volume in the shape of a cube) and over the appropriate averaging time.

APPENDIX D

The Validation Measurements

DUT: Dipole 835 MHz; Serial: 4d050
Program Name: 835MHz Dipole Validation 2012.01.13
Procedure Name: 835MHz @ 100mW
Meas. Ambient Temp(celsius)-22.8,Tissue Temp(celsius)-22.6;Test Date-13/Jan/2012

Communication System: CW; ;Duty Cycle: 1:1
Medium parameters used: $f = 835 \text{ MHz}$; $\sigma = 0.92 \text{ mho/m}$; $\epsilon_r = 42.4$; $\rho = 1000 \text{ kg/m}^3$
Phantom section: Flat Section

DASY4 Configuration:

- Probe: EX3DV4 - SN3750; ConvF(8.26, 8.26, 8.26); Calibrated: 2011-04-14
- Sensor-Surface: 4mm (Mechanical Surface Detection)
- Electronics: DAE4 Sn533; Calibrated: 2011-09-21
- Phantom: PHANTOM #1; Type: SAM; Serial: TP-1143
- Measurement SW: DASY4, V4.7 Build 80; Postprocessing SW: SEMCAD, V1.8 Build 184

835MHz @ 100mW/Area Scan (51x51x1): Measurement grid: dx=20mm, dy=20mm
Maximum value of SAR (interpolated) = 1.06 mW/g

835MHz @ 100mW/Zoom Scan (5x5x7)/Cube 0: Measurement grid: dx=8mm, dy=8mm, dz=5mm

Reference Value = 33.8 V/m; Power Drift = 0.024 dB

Peak SAR (extrapolated) = 1.47 W/kg

SAR(1 g) = 0.975 mW/g; SAR(10 g) = 0.636 mW/g

Maximum value of SAR (measured) = 1.06 mW/g

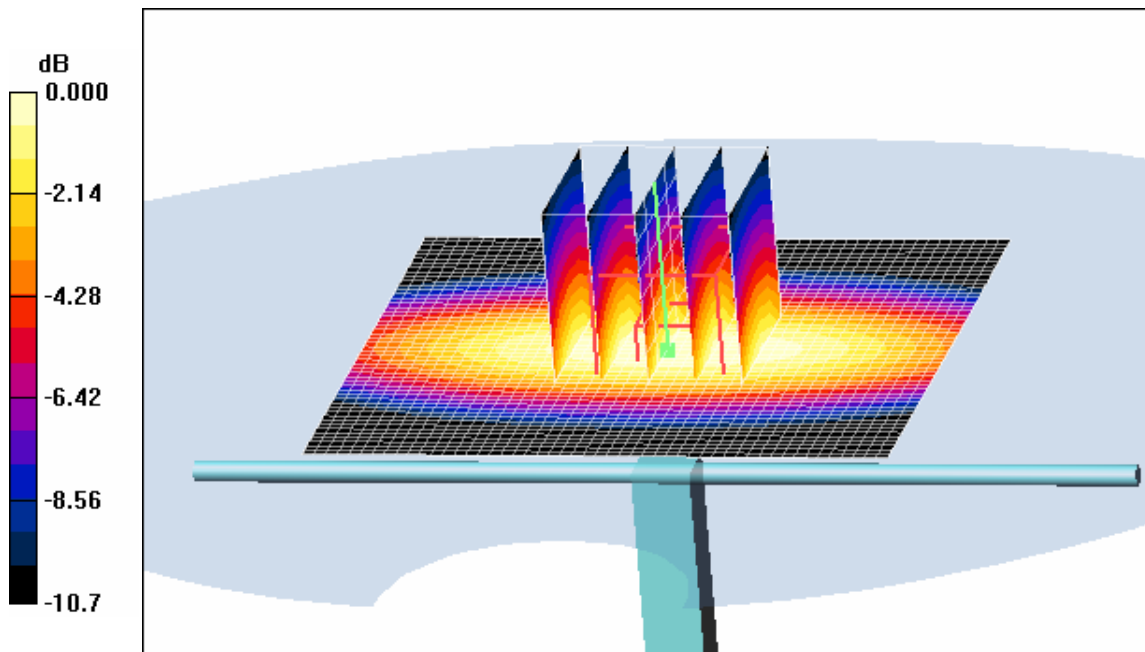

0 dB = 1.06mW/g

DUT: Dipole 835 MHz; Serial: 4d050
Program Name: 835MHz Dipole Validation 2012.01.13
Procedure Name: 835MHz @ 100mW
Meas. Ambient Temp(celsius)-22.7,Tissue Temp(celsius)-22.5;Test Date-13/Jan/2012

Communication System: CW; ;Duty Cycle: 1:1
Medium parameters used: $f = 835 \text{ MHz}$; $\sigma = 0.98 \text{ mho/m}$; $\epsilon_r = 54.3$; $\rho = 1000 \text{ kg/m}^3$
Phantom section: Left Section

DASY4 Configuration:

- Probe: EX3DV4 - SN3750; ConvF(8.34, 8.34, 8.34); Calibrated: 2011-04-14
- Sensor-Surface: 4mm (Mechanical Surface Detection)
- Electronics: DAE4 Sn533; Calibrated: 2011-09-21
- Phantom: Triple Flat Phantom 5.1; Type: Triple Flat Phantom 5.1; Serial: 1001
- Measurement SW: DASY4, V4.7 Build 80; Postprocessing SW: SEMCAD, V1.8 Build 184

835MHz @ 100mW/Area Scan (51x51x1): Measurement grid: dx=20mm, dy=20mm
Maximum value of SAR (interpolated) = 1.13 mW/g

835MHz @ 100mW/Zoom Scan (5x5x7)/Cube 0: Measurement grid: dx=8mm, dy=8mm, dz=5mm

Reference Value = 32.8 V/m; Power Drift = -0.013 dB

Peak SAR (extrapolated) = 1.55 W/kg

SAR(1 g) = 1.04 mW/g; SAR(10 g) = 0.681 mW/g

Maximum value of SAR (measured) = 1.12 mW/g

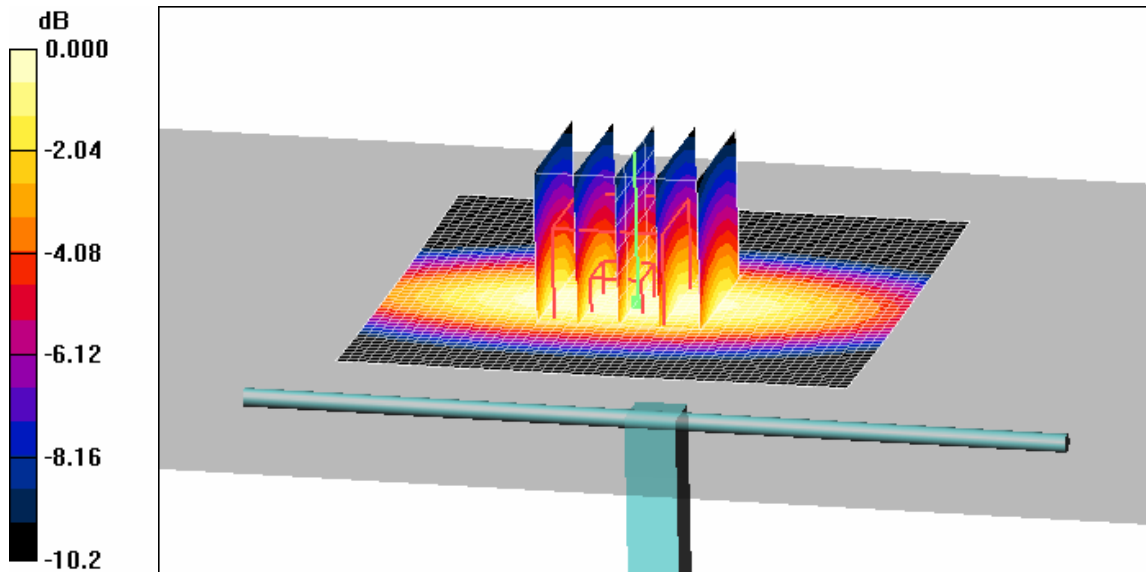

0 dB = 1.12mW/g

DUT: Dipole 1900 MHz; Serial: 5d082

Program Name: 1900MHz Dipole Validation 2012.01.12

Procedure Name: 1900MHz @ 100mW Head

Meas. Ambient Temp(celsius)-23.0,Tissue Temp(celsius)-22.8;Test Date-12/Jan/2012

Communication System: CW; ;Duty Cycle: 1:1

Medium parameters used: $f = 1900 \text{ MHz}$; $\sigma = 1.4 \text{ mho/m}$; $\epsilon_r = 38.8$; $\rho = 1000 \text{ kg/m}^3$

Phantom section: Flat Section

DASY4 Configuration:

- Probe: ES3DV2 - SN3017; ConvF(5.03, 5.03, 5.03); Calibrated: 2011-05-20

- Sensor-Surface: 4mm (Mechanical Surface Detection)

- Electronics: DAE4 Sn468; Calibrated: 2011-05-13

- Phantom: PHANTOM #2; Type: SAM; Serial: TP-1604

- Measurement SW: DASY4, V4.7 Build 80; Postprocessing SW: SEMCAD, V1.8 Build 184

1900MHz @ 100mW Head/Area Scan (51x51x1): Measurement grid: $dx=20\text{mm}$, $dy=20\text{mm}$

Maximum value of SAR (interpolated) = 5.55 mW/g

1900MHz @ 100mW Head/Zoom Scan (5x5x7)/Cube 0: Measurement grid: $dx=8\text{mm}$,

$dy=8\text{mm}$, $dz=5\text{mm}$

Reference Value = 49.3 V/m; Power Drift = -0.014 dB

Peak SAR (extrapolated) = 7.58 W/kg

SAR(1 g) = 4.17 mW/g; SAR(10 g) = 2.19 mW/g

Maximum value of SAR (measured) = 4.62 mW/g

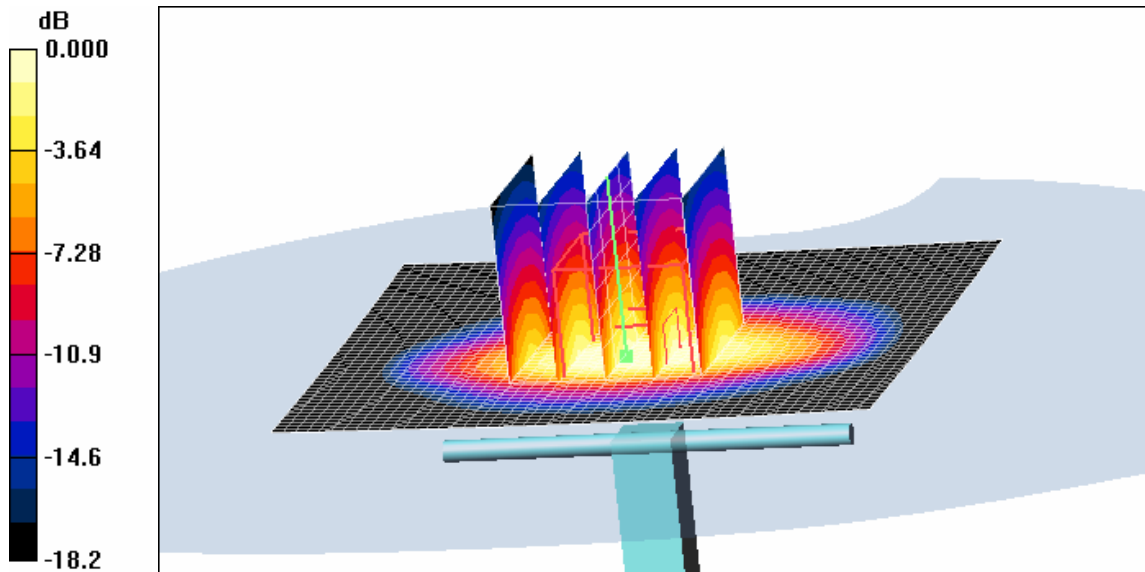

0 dB = 4.62mW/g

DUT: Dipole 1900 MHz; Serial: 5d082
Program Name: 1900MHz Dipole Validation 2012.01.12
Procedure Name: 1900MHz @ 100mW
Meas. Ambient Temp(celsius)-23.0,Tissue Temp(celsius)-22.8;Test Date-12/Jan/2012

Communication System: CW; ;Duty Cycle: 1:1
Medium parameters used: $f = 1900 \text{ MHz}$; $\sigma = 1.54 \text{ mho/m}$; $\epsilon_r = 52.6$; $\rho = 1000 \text{ kg/m}^3$
Phantom section: Right Section

DASY4 Configuration:

- Probe: EX3DV4 - SN3750; ConvF(7.12, 7.12, 7.12); Calibrated: 2011-04-14
- Sensor-Surface: 4mm (Mechanical Surface Detection)
- Electronics: DAE4 Sn533; Calibrated: 2011-09-21
- Phantom: Triple Flat Phantom 5.1; Type: Triple Flat Phantom 5.1; Serial: 1001
- Measurement SW: DASY4, V4.7 Build 80; Postprocessing SW: SEMCAD, V1.8 Build 184

1900MHz @ 100mW/Area Scan (51x51x1): Measurement grid: $dx=20\text{mm}$, $dy=20\text{mm}$
Maximum value of SAR (interpolated) = 5.27 mW/g

1900MHz @ 100mW/Zoom Scan (5x5x7)/Cube 0: Measurement grid: $dx=8\text{mm}$, $dy=8\text{mm}$,
 $dz=5\text{mm}$

Reference Value = 51.4 V/m; Power Drift = -0.031 dB

Peak SAR (extrapolated) = 7.18 W/kg

SAR(1 g) = 3.98 mW/g; SAR(10 g) = 2.09 mW/g

Maximum value of SAR (measured) = 4.34 mW/g

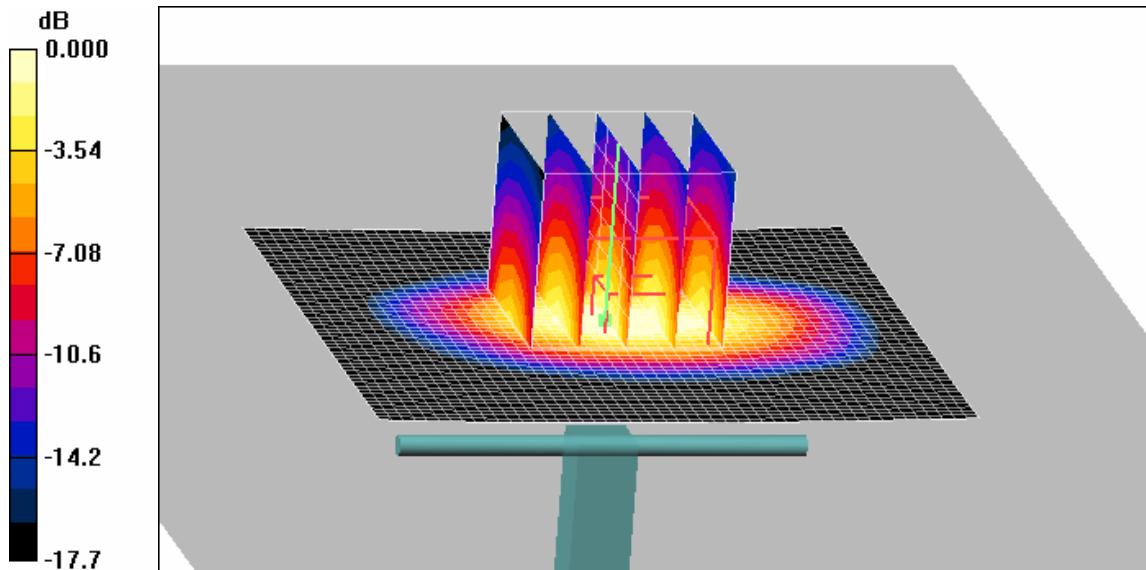

0 dB = 4.34mW/g

DUT: Dipole 2450 MHz; Serial: D2450V2 - SN:708

Program Name: 2450MHz Dipole Head Validation 2012.01.13

Procedure Name: 2450MHz @ 100mW

Meas. Ambient Temp(celsius)-22.7,Tissue Temp(celsius)-22.6;Test Date-13/Jan/2012

Communication System: CW; ;Duty Cycle: 1:1

Medium parameters used: $f = 2450 \text{ MHz}$; $\sigma = 1.85 \text{ mho/m}$; $\epsilon_r = 38.6$; $\rho = 1000 \text{ kg/m}^3$

Phantom section: Flat Section

DASY4 Configuration:

- Probe: ES3DV2 - SN3017; ConvF(4.28, 4.28, 4.28); Calibrated: 2011-05-20

- Sensor-Surface: 4mm (Mechanical Surface Detection)

- Electronics: DAE4 Sn468; Calibrated: 2011-05-13

- Phantom: PHANTOM #2; Type: SAM; Serial: TP-1604

- Measurement SW: DASY4, V4.7 Build 80; Postprocessing SW: SEMCAD, V1.8 Build 184

2450MHz @ 100mW/Area Scan (51x51x1): Measurement grid: $dx=20\text{mm}$, $dy=20\text{mm}$

Maximum value of SAR (interpolated) = 8.61 mW/g

2450MHz @ 100mW/Zoom Scan (5x5x7)/Cube 0: Measurement grid: $dx=8\text{mm}$, $dy=8\text{mm}$, $dz=5\text{mm}$

Reference Value = 58.8 V/m; Power Drift = 0.006 dB

Peak SAR (extrapolated) = 11.7 W/kg

SAR(1 g) = 5.64 mW/g; SAR(10 g) = 2.64 mW/g

Maximum value of SAR (measured) = 6.35 mW/g

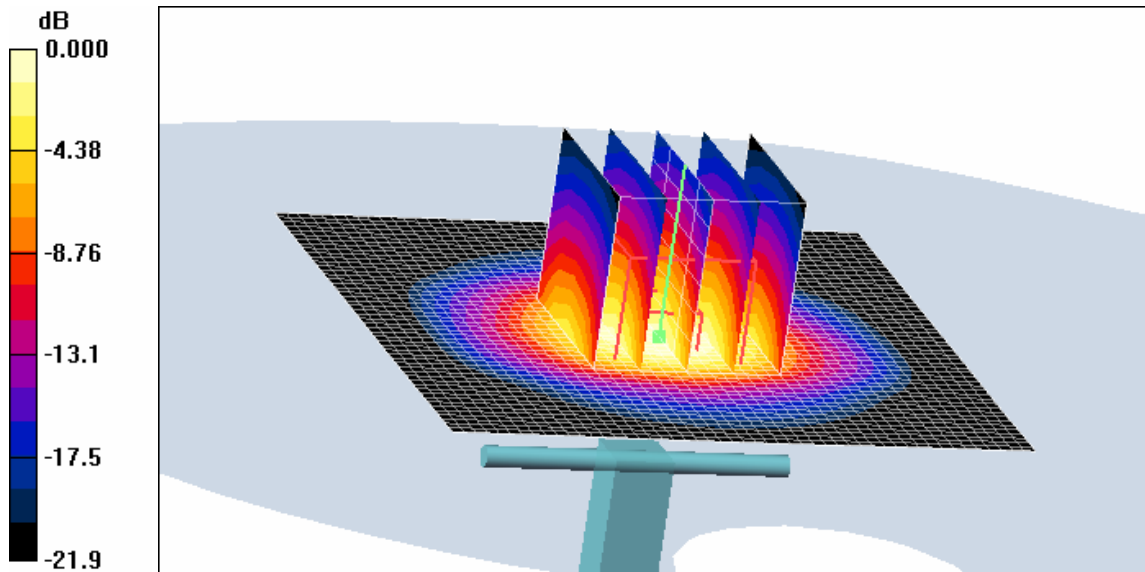

0 dB = 6.35mW/g

DUT: Dipole 2450 MHz; Serial: 708
Program Name: 2450MHz Dipole Validation 2012.01.13
Procedure Name: 2450MHz @ 100mW Body
Meas. Ambient Temp(celsius)-22.7,Tissue Temp(celsius)-22.6;Test Date-13/Jan/2012

Communication System: CW; ;Duty Cycle: 1:1
Medium parameters used: $f = 2450 \text{ MHz}$; $\sigma = 1.95 \text{ mho/m}$; $\epsilon_r = 51.5$; $\rho = 1000 \text{ kg/m}^3$
Phantom section: Right Section

DASY4 Configuration:

- Probe: EX3DV4 - SN3750; ConvF(6.76, 6.76, 6.76); Calibrated: 2011-04-14
- Sensor-Surface: 4mm (Mechanical Surface Detection)
- Electronics: DAE4 Sn533; Calibrated: 2011-09-21
- Phantom: Triple Flat Phantom 5.1; Type: Triple Flat Phantom 5.1; Serial: 1001
- Measurement SW: DASY4, V4.7 Build 80; Postprocessing SW: SEMCAD, V1.8 Build 184

2450MHz @ 100mW Body/Area Scan (51x51x1): Measurement grid: $dx=20\text{mm}$, $dy=20\text{mm}$
Maximum value of SAR (interpolated) = 8.05 mW/g

2450MHz @ 100mW Body/Zoom Scan (5x5x7)/Cube 0: Measurement grid: $dx=8\text{mm}$,
 $dy=8\text{mm}$, $dz=5\text{mm}$

Reference Value = 36.2 V/m; Power Drift = -0.941 dB

Peak SAR (extrapolated) = 9.28 W/kg

SAR(1 g) = 4.76 mW/g; SAR(10 g) = 2.25 mW/g

Maximum value of SAR (measured) = 6.70 mW/g

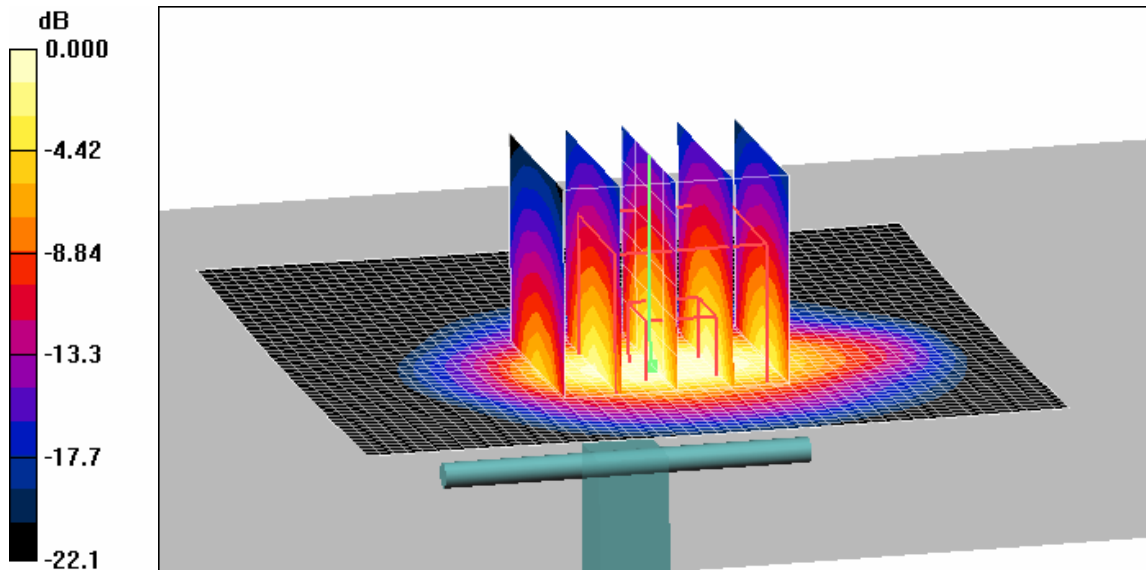

0 dB = 6.70mW/g

APPENDIX E

Plots of The SAR Measurements

DUT: GT-S3770Y; Serial: FI-320-E

Program Name: GT-S3770Y GSM850 Right (Job No. : FI-320)

Procedure Name: Cheek/Touch, Ch.190, Ant.Intenna, Bat.Standard

Meas. Ambient Temp(celsius)-22.8,Tissue Temp(celsius)-22.6;Test Date-13/Jan/2012

Communication System: GSM 850; ;Duty Cycle: 1:8.3

Medium parameters used: $f = 836.6$ MHz; $\sigma = 0.92$ mho/m; $\epsilon_r = 42.4$; $\rho = 1000$ kg/m³

Phantom section: Right Section

DASY4 Configuration:

- Probe: EX3DV4 - SN3750; ConvF(8.26, 8.26, 8.26); Calibrated: 2011-04-14

- Sensor-Surface: 4mm (Mechanical Surface Detection)

- Electronics: DAE4 Sn533; Calibrated: 2011-09-21

- Phantom: PHANTOM #1; Type: SAM; Serial: TP-1143

- Measurement SW: DASY4, V4.7 Build 80; Postprocessing SW: SEMCAD, V1.8 Build 184

Cheek/Touch, Ch.190, Ant.Intenna, Bat.Standard/Area Scan (51x71x1): Measurement grid:

dx=20mm, dy=20mm

Maximum value of SAR (interpolated) = 0.530 mW/g

Cheek/Touch, Ch.190, Ant.Intenna, Bat.Standard/Zoom Scan (5x5x7)/Cube 0:

Measurement grid: dx=8mm, dy=8mm, dz=5mm

Reference Value = 23.2 V/m; Power Drift = -0.057 dB

Peak SAR (extrapolated) = 0.537 W/kg

SAR(1 g) = 0.405 mW/g; SAR(10 g) = 0.292 mW/g

Maximum value of SAR (measured) = 0.478 mW/g

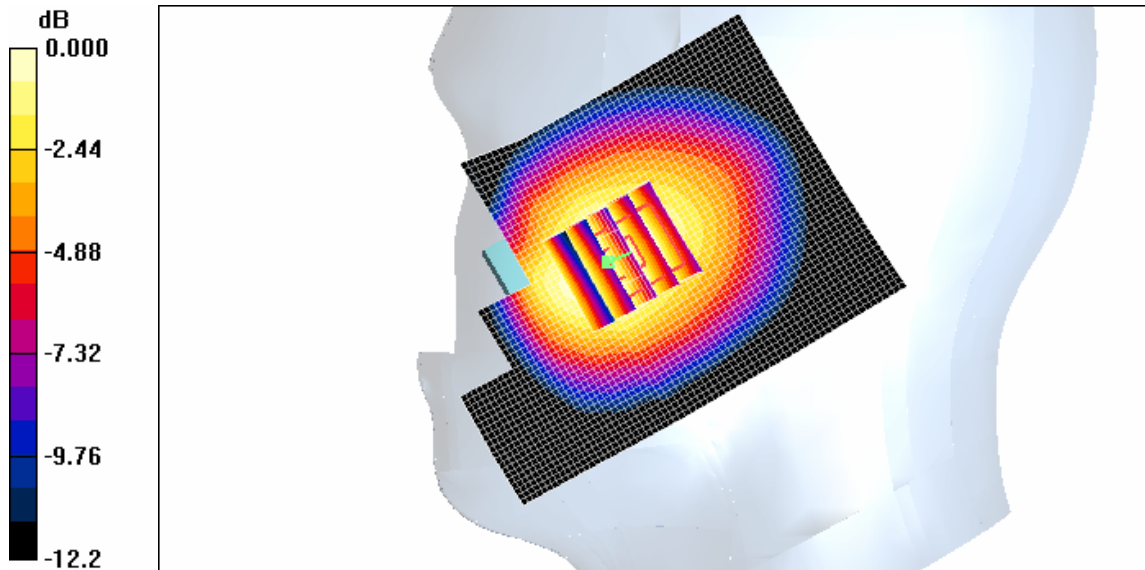

0 dB = 0.478mW/g

DUT: GT-S3770Y; Serial: FI-320-E

Program Name: GT-S3770Y GSM850 Right (Job No. : FI-320)

Procedure Name: Ear/Tilt, Ch.190, Ant.Intenna, Bat.Standard

Meas. Ambient Temp(celsius)-22.8,Tissue Temp(celsius)-22.6;Test Date-13/Jan/2012

Communication System: GSM 850; ;Duty Cycle: 1:8.3

Medium parameters used: $f = 836.6$ MHz; $\sigma = 0.92$ mho/m; $\epsilon_r = 42.4$; $\rho = 1000$ kg/m³

Phantom section: Right Section

DASY4 Configuration:

- Probe: EX3DV4 - SN3750; ConvF(8.26, 8.26, 8.26); Calibrated: 2011-04-14

- Sensor-Surface: 4mm (Mechanical Surface Detection)

- Electronics: DAE4 Sn533; Calibrated: 2011-09-21

- Phantom: PHANTOM #1; Type: SAM; Serial: TP-1143

- Measurement SW: DASY4, V4.7 Build 80; Postprocessing SW: SEMCAD, V1.8 Build 184

Ear/Tilt, Ch.190, Ant.Intenna, Bat.Standard/Area Scan (51x71x1): Measurement grid:

dx=20mm, dy=20mm

Maximum value of SAR (interpolated) = 0.233 mW/g

Ear/Tilt, Ch.190, Ant.Intenna, Bat.Standard/Zoom Scan (5x5x7)/Cube 0: Measurement grid:

dx=8mm, dy=8mm, dz=5mm

Reference Value = 11.3 V/m; Power Drift = 0.015 dB

Peak SAR (extrapolated) = 0.278 W/kg

SAR(1 g) = 0.216 mW/g; SAR(10 g) = 0.160 mW/g

Maximum value of SAR (measured) = 0.229 mW/g

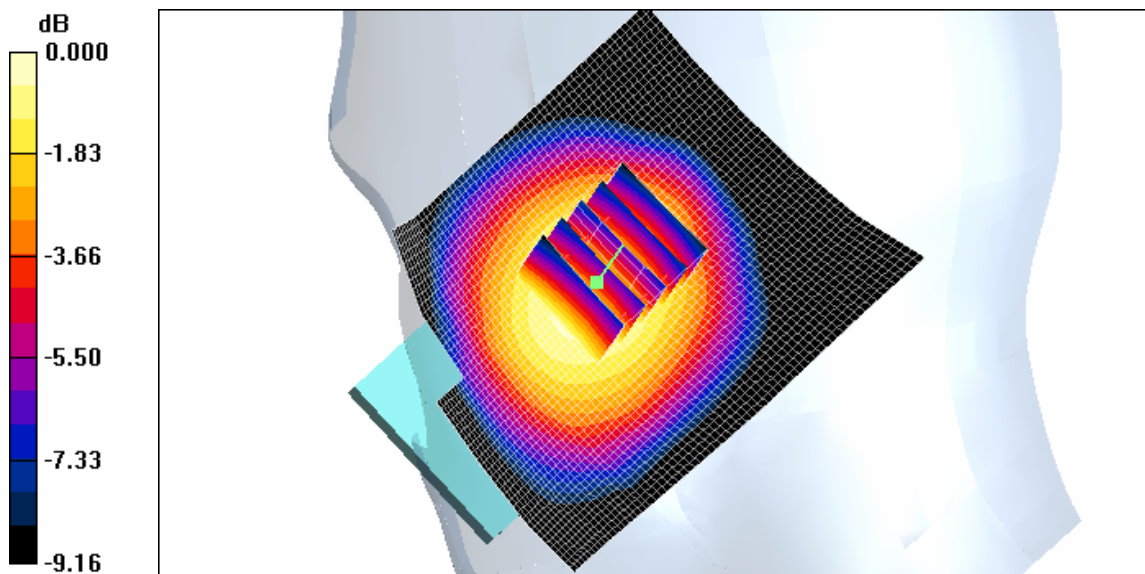

0 dB = 0.229mW/g

DUT: GT-S3770Y; Serial: FI-320-E

Program Name: GT-S3770Y GSM850 Left (Job No. : FI-320)

Procedure Name: Cheek/Touch, Ch.190, Ant.Intenna, Bat.Standard

Meas. Ambient Temp(celsius)-22.8,Tissue Temp(celsius)-22.6;Test Date-13/Jan/2012

Communication System: GSM 850; ;Duty Cycle: 1:8.3

Medium parameters used: $f = 836.6$ MHz; $\sigma = 0.92$ mho/m; $\epsilon_r = 42.4$; $\rho = 1000$ kg/m³

Phantom section: Left Section

DASY4 Configuration:

- Probe: EX3DV4 - SN3750; ConvF(8.26, 8.26, 8.26); Calibrated: 2011-04-14

- Sensor-Surface: 4mm (Mechanical Surface Detection)

- Electronics: DAE4 Sn533; Calibrated: 2011-09-21

- Phantom: PHANTOM #1; Type: SAM; Serial: TP-1143

- Measurement SW: DASY4, V4.7 Build 80; Postprocessing SW: SEMCAD, V1.8 Build 184

Cheek/Touch, Ch.190, Ant.Intenna, Bat.Standard/Area Scan (51x71x1): Measurement grid:

dx=20mm, dy=20mm

Maximum value of SAR (interpolated) = 0.572 mW/g

Cheek/Touch, Ch.190, Ant.Intenna, Bat.Standard/Zoom Scan (5x5x7)/Cube 0:

Measurement grid: dx=8mm, dy=8mm, dz=5mm

Reference Value = 23.3 V/m; Power Drift = 0.024 dB

Peak SAR (extrapolated) = 0.715 W/kg

SAR(1 g) = 0.499 mW/g; SAR(10 g) = 0.348 mW/g

Maximum value of SAR (measured) = 0.529 mW/g

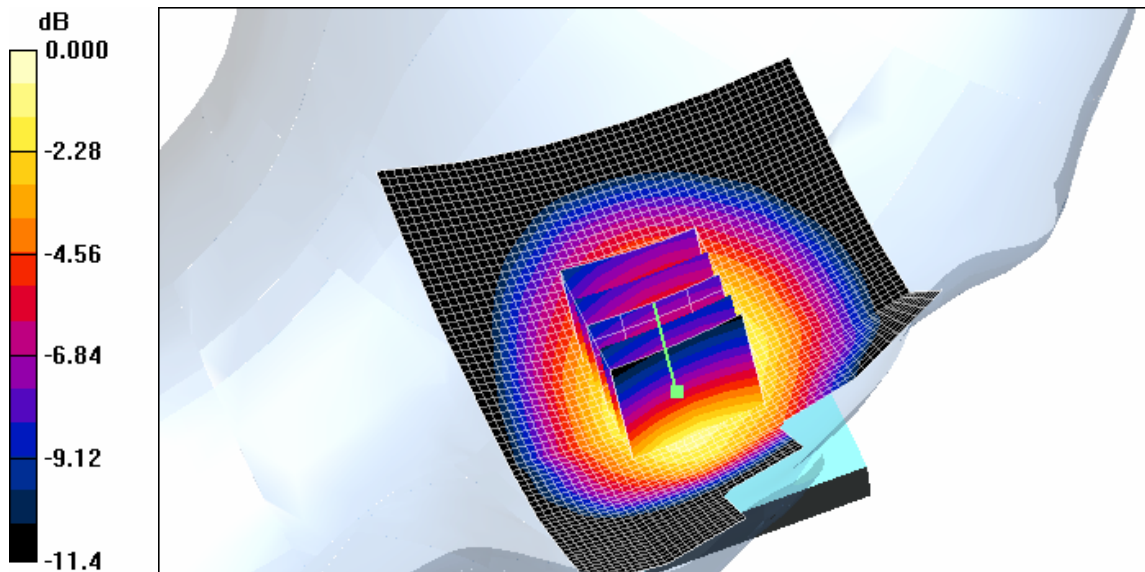

0 dB = 0.529mW/g

DUT: GT-S3770Y; Serial: FI-320-E

Program Name: GT-S3770Y GSM850 Left (Job No. : FI-320)

Procedure Name: Ear/Tilt, Ch.190, Ant.Intenna, Bat.Standard

Meas. Ambient Temp(celsius)-22.8,Tissue Temp(celsius)-22.6;Test Date-13/Jan/2012

Communication System: GSM 850; ;Duty Cycle: 1:8.3

Medium parameters used: $f = 836.6$ MHz; $\sigma = 0.92$ mho/m; $\epsilon_r = 42.4$; $\rho = 1000$ kg/m³

Phantom section: Left Section

DASY4 Configuration:

- Probe: EX3DV4 - SN3750; ConvF(8.26, 8.26, 8.26); Calibrated: 2011-04-14
- Sensor-Surface: 4mm (Mechanical Surface Detection)
- Electronics: DAE4 Sn533; Calibrated: 2011-09-21
- Phantom: PHANTOM #1; Type: SAM; Serial: TP-1143
- Measurement SW: DASY4, V4.7 Build 80; Postprocessing SW: SEMCAD, V1.8 Build 184

Ear/Tilt, Ch.190, Ant.Intenna, Bat.Standard/Area Scan (51x71x1): Measurement grid:

dx=20mm, dy=20mm

Maximum value of SAR (interpolated) = 0.213 mW/g

Ear/Tilt, Ch.190, Ant.Intenna, Bat.Standard/Zoom Scan (5x5x7)/Cube 0: Measurement grid:

dx=8mm, dy=8mm, dz=5mm

Reference Value = 12.8 V/m; Power Drift = -0.052 dB

Peak SAR (extrapolated) = 0.258 W/kg

SAR(1 g) = 0.200 mW/g; SAR(10 g) = 0.148 mW/g

Maximum value of SAR (measured) = 0.213 mW/g

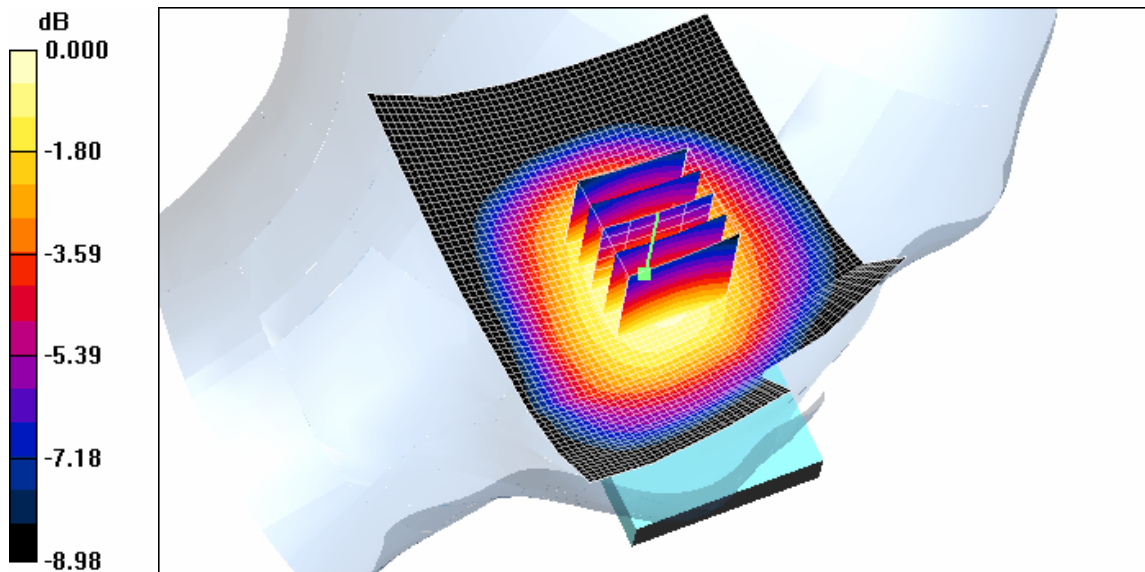

0 dB = 0.213mW/g

DUT: GT-S3770Y; Serial: FI-320-E

Program Name: GT-S3770Y GSM850 Left (Job No. : FI-320)

Procedure Name: Cheek/Touch, Ch.190, Ant.Intenna, Bat.Standard

Meas. Ambient Temp(celsius)-22.8,Tissue Temp(celsius)-22.6;Test Date-13/Jan/2012

Communication System: GSM 850; Frequency: 836.6 MHz;Duty Cycle: 1:8.3

Medium parameters used: $f = 836.6$ MHz; $\sigma = 0.92$ mho/m; $\epsilon_r = 42.4$; $\rho = 1000$ kg/m³

Phantom section: Left Section

DASY4 Configuration:

- Probe: EX3DV4 - SN3750; ConvF(8.26, 8.26, 8.26); Calibrated: 2011-04-14
- Sensor-Surface: 4mm (Mechanical Surface Detection)
- Electronics: DAE4 Sn533; Calibrated: 2011-09-21
- Phantom: PHANTOM #1; Type: SAM; Serial: TP-1143
- Measurement SW: DASY4, V4.7 Build 80; Postprocessing SW: SEMCAD, V1.8 Build 184

Cheek/Touch, Ch.190, Ant.Intenna, Bat.Standard/Area Scan (51x71x1): Measurement grid:

dx=20mm, dy=20mm

Maximum value of SAR (interpolated) = 0.572 mW/g

Cheek/Touch, Ch.190, Ant.Intenna, Bat.Standard/Zoom Scan (5x5x7)/Cube 0:

Measurement grid: dx=8mm, dy=8mm, dz=5mm

Reference Value = 23.3 V/m; Power Drift = 0.024 dB

Peak SAR (extrapolated) = 0.715 W/kg

SAR(1 g) = 0.499 mW/g; SAR(10 g) = 0.348 mW/g

Maximum value of SAR (measured) = 0.529 mW/g

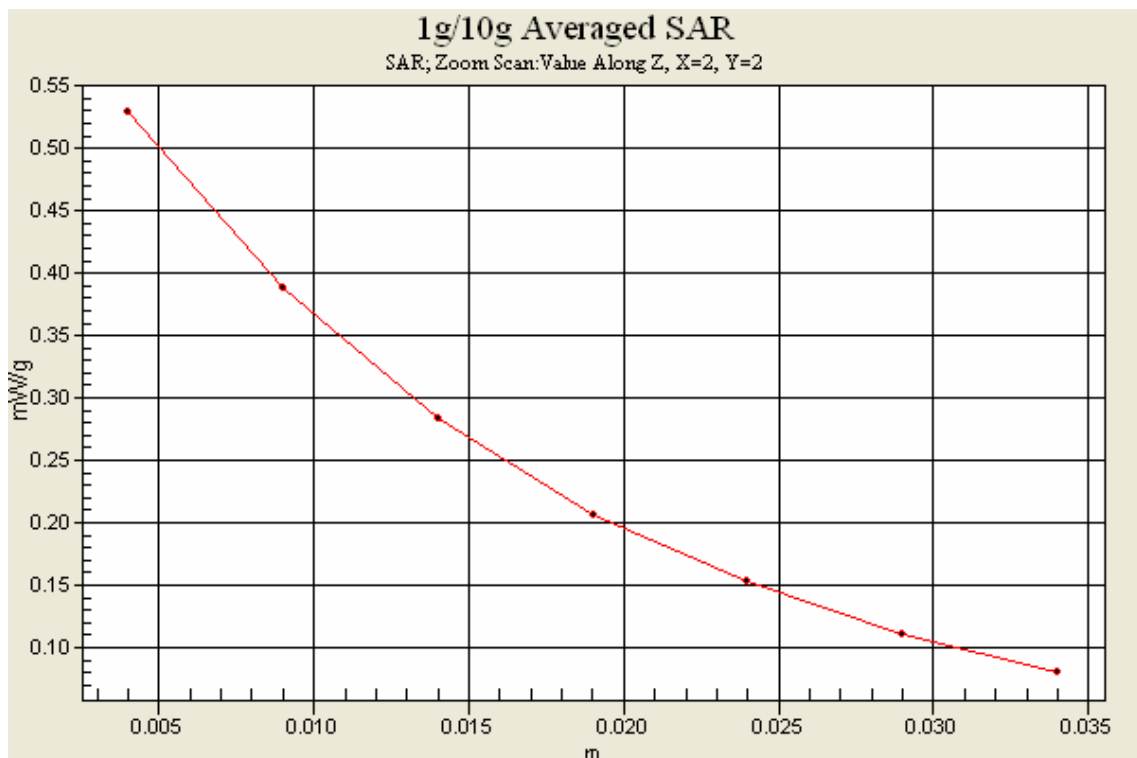

DUT: GT-S3770Y; Serial: FI-320-E

Program Name: GT-S3770Y GPRS850 Body (Job No. : FI-320)

Procedure Name: Body, Ch.190, Ant.Intenna, Bat.Standard, Back, 2Tx, 15mm

Meas. Ambient Temp(celsius)-22.7,Tissue Temp(celsius)-22.5;Test Date-13/Jan/2012

Communication System: GPRS 850; ;Duty Cycle: 1:4.15

Medium parameters used: $f = 836.6$ MHz; $\sigma = 0.98$ mho/m; $\epsilon_r = 54.3$; $\rho = 1000$ kg/m³

Phantom section: Left Section

DASY4 Configuration:

- Probe: EX3DV4 - SN3750; ConvF(8.34, 8.34, 8.34); Calibrated: 2011-04-14
- Sensor-Surface: 4mm (Mechanical Surface Detection)
- Electronics: DAE4 Sn533; Calibrated: 2011-09-21
- Phantom: Triple Flat Phantom 5.1; Type: Triple Flat Phantom 5.1; Serial: 1001
- Measurement SW: DASY4, V4.7 Build 80; Postprocessing SW: SEMCAD, V1.8 Build 184

Body, Ch.190, Ant.Intenna, Bat.Standard, Back, 2Tx, 15mm/Area Scan (51x71x1):

Measurement grid: dx=20mm, dy=20mm

Maximum value of SAR (interpolated) = 0.445 mW/g

Body, Ch.190, Ant.Intenna, Bat.Standard, Back, 2Tx, 15mm/Zoom Scan 2 (5x5x7)/Cube 0:

Measurement grid: dx=8mm, dy=8mm, dz=5mm

Reference Value = 18.9 V/m; Power Drift = -0.089 dB

Peak SAR (extrapolated) = 0.446 W/kg

SAR(1 g) = 0.333 mW/g; SAR(10 g) = 0.236 mW/g

Maximum value of SAR (measured) = 0.394 mW/g

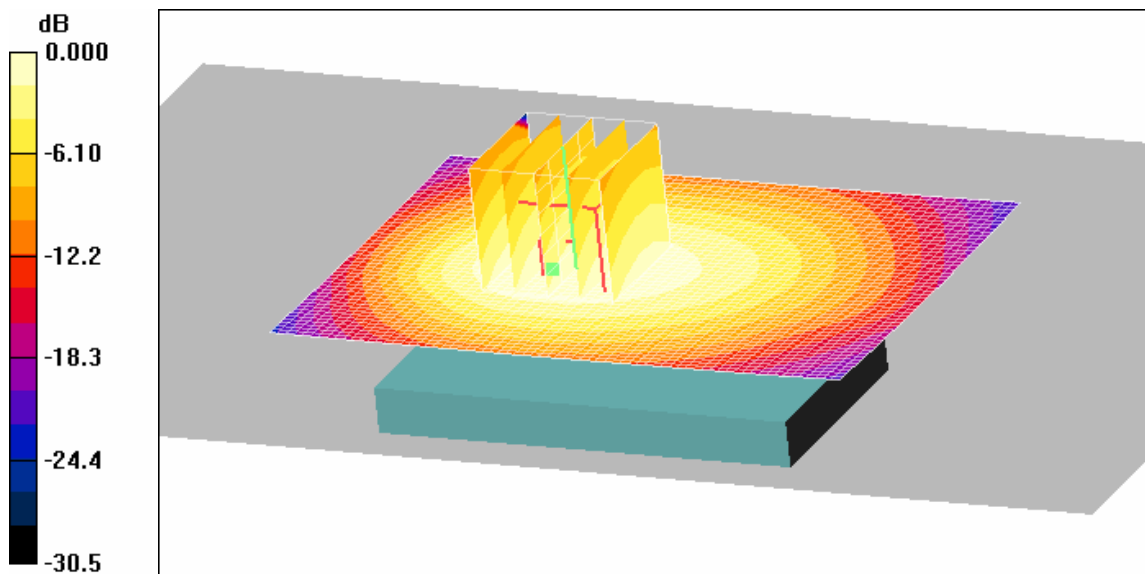

0 dB = 0.394mW/g

DUT: GT-S3770Y; Serial: FI-320-E

Program Name: GT-S3770Y GPRS850 Body (Job No. : FI-320)

Procedure Name: Body, Ch.190, Ant.Intenna, Bat.Standard, Back, 3Tx, 15mm

Meas. Ambient Temp(celsius)-22.7,Tissue Temp(celsius)-22.5;Test Date-13/Jan/2012

Communication System: GPRS 850; ;Duty Cycle: 1:2.767

Medium parameters used: $f = 836.6$ MHz; $\sigma = 0.98$ mho/m; $\epsilon_r = 54.3$; $\rho = 1000$ kg/m³

Phantom section: Left Section

DASY4 Configuration:

- Probe: EX3DV4 - SN3750; ConvF(8.34, 8.34, 8.34); Calibrated: 2011-04-14
- Sensor-Surface: 4mm (Mechanical Surface Detection)
- Electronics: DAE4 Sn533; Calibrated: 2011-09-21
- Phantom: Triple Flat Phantom 5.1; Type: Triple Flat Phantom 5.1; Serial: 1001
- Measurement SW: DASY4, V4.7 Build 80; Postprocessing SW: SEMCAD, V1.8 Build 184

Body, Ch.190, Ant.Intenna, Bat.Standard, Back, 3Tx, 15mm/Area Scan (51x71x1):

Measurement grid: dx=20mm, dy=20mm

Maximum value of SAR (interpolated) = 0.514 mW/g

Body, Ch.190, Ant.Intenna, Bat.Standard, Back, 3Tx, 15mm/Zoom Scan (5x5x7)/Cube 0:

Measurement grid: dx=8mm, dy=8mm, dz=5mm

Reference Value = 20.4 V/m; Power Drift = -0.078 dB

Peak SAR (extrapolated) = 0.527 W/kg

SAR(1 g) = 0.393 mW/g; SAR(10 g) = 0.279 mW/g

Maximum value of SAR (measured) = 0.470 mW/g

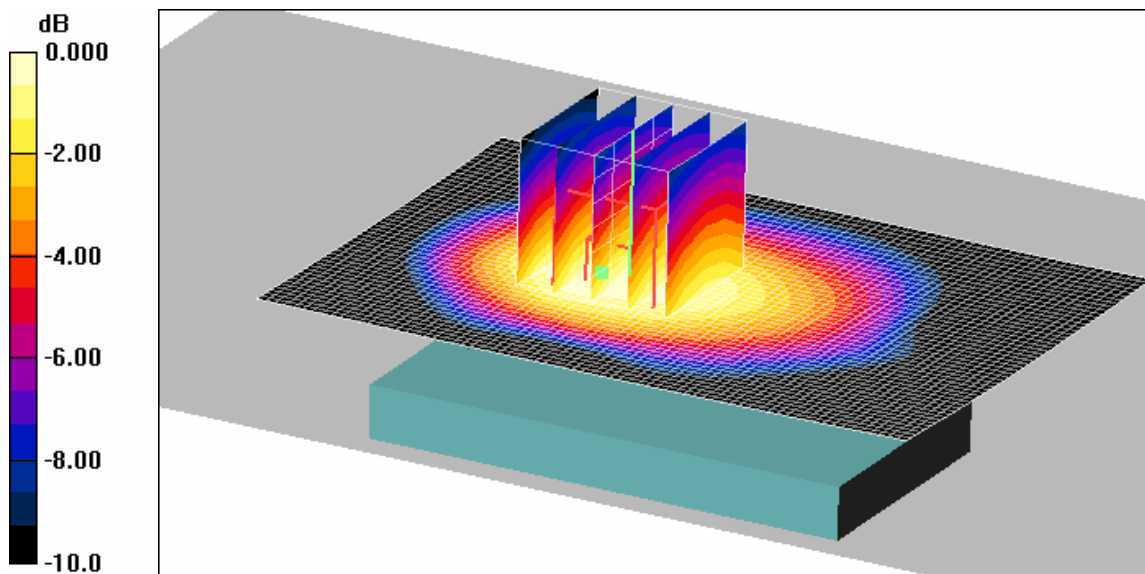

0 dB = 0.470mW/g

DUT: GT-S3770Y; Serial: FI-320-E

Program Name: GT-S3770Y GPRS850 Body (Job No. : FI-320)

Procedure Name: Body, Ch.190, Ant.Intenna, Bat.Standard, Back, 4Tx, 15mm

Meas. Ambient Temp(celsius)-22.7,Tissue Temp(celsius)-22.5;Test Date-13/Jan/2012

Communication System: GPRS 850; ;Duty Cycle: 1:2.075

Medium parameters used: $f = 836.6$ MHz; $\sigma = 0.98$ mho/m; $\epsilon_r = 54.3$; $\rho = 1000$ kg/m³

Phantom section: Left Section

DASY4 Configuration:

- Probe: EX3DV4 - SN3750; ConvF(8.34, 8.34, 8.34); Calibrated: 2011-04-14

- Sensor-Surface: 4mm (Mechanical Surface Detection)

- Electronics: DAE4 Sn533; Calibrated: 2011-09-21

- Phantom: Triple Flat Phantom 5.1; Type: Triple Flat Phantom 5.1; Serial: 1001

- Measurement SW: DASY4, V4.7 Build 80; Postprocessing SW: SEMCAD, V1.8 Build 184

Body, Ch.190, Ant.Intenna, Bat.Standard, Back, 4Tx, 15mm/Area Scan (51x71x1):

Measurement grid: dx=20mm, dy=20mm

Maximum value of SAR (interpolated) = 0.487 mW/g

Body, Ch.190, Ant.Intenna, Bat.Standard, Back, 4Tx, 15mm/Zoom Scan (5x5x7)/Cube 0:

Measurement grid: dx=8mm, dy=8mm, dz=5mm

Reference Value = 18.5 V/m; Power Drift = -0.072 dB

Peak SAR (extrapolated) = 0.547 W/kg

SAR(1 g) = 0.379 mW/g; SAR(10 g) = 0.268 mW/g

Maximum value of SAR (measured) = 0.440 mW/g

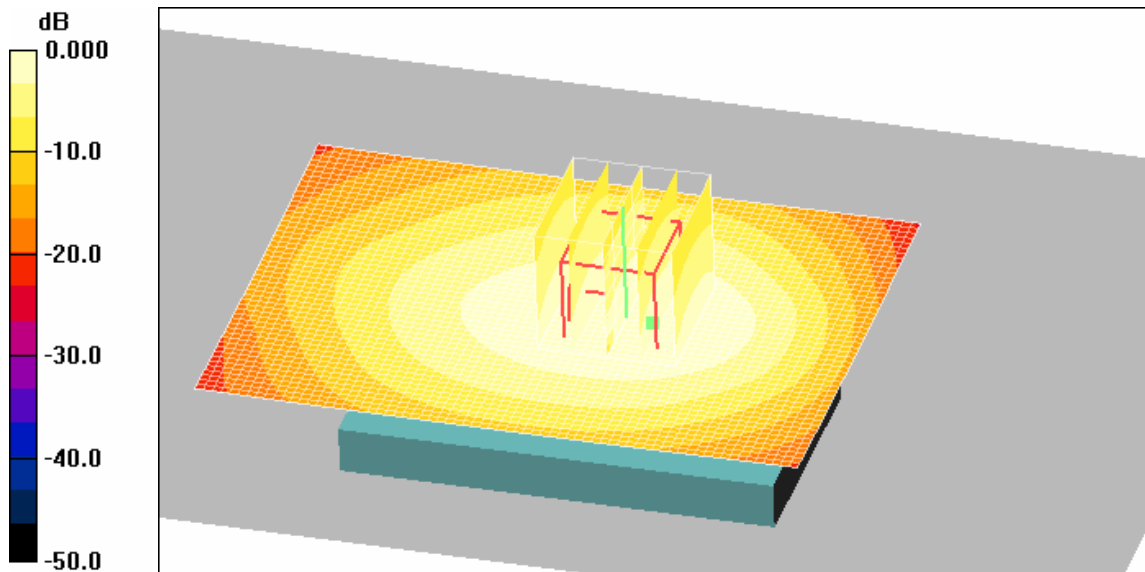

0 dB = 0.440mW/g

DUT: GT-S3770Y; Serial: FI-320-E

Program Name: GT-S3770Y GPRS850 Body (Job No. : FI-320)

Procedure Name: Body, Ch.190, Ant.Intenna, Bat.Standard, Back, 3Tx, 15mm

Meas. Ambient Temp(celsius)-22.7,Tissue Temp(celsius)-22.5;Test Date-13/Jan/2012

Communication System: GPRS 850; Frequency: 836.6 MHz;Duty Cycle: 1:2.767

Medium parameters used: $f = 836.6$ MHz; $\sigma = 0.98$ mho/m; $\epsilon_r = 54.3$; $\rho = 1000$ kg/m³

Phantom section: Left Section

DASY4 Configuration:

- Probe: EX3DV4 - SN3750; ConvF(8.34, 8.34, 8.34); Calibrated: 2011-04-14

- Sensor-Surface: 4mm (Mechanical Surface Detection)

- Electronics: DAE4 Sn533; Calibrated: 2011-09-21

- Phantom: Triple Flat Phantom 5.1; Type: Triple Flat Phantom 5.1; Serial: 1001

- Measurement SW: DASY4, V4.7 Build 80; Postprocessing SW: SEMCAD, V1.8 Build 184

Body, Ch.190, Ant.Intenna, Bat.Standard, Back, 3Tx, 15mm/Area Scan (51x71x1):

Measurement grid: dx=20mm, dy=20mm

Maximum value of SAR (interpolated) = 0.514 mW/g

Body, Ch.190, Ant.Intenna, Bat.Standard, Back, 3Tx, 15mm/Zoom Scan (5x5x7)/Cube 0:

Measurement grid: dx=8mm, dy=8mm, dz=5mm

Reference Value = 20.4 V/m; Power Drift = -0.078 dB

Peak SAR (extrapolated) = 0.527 W/kg

SAR(1 g) = 0.393 mW/g; SAR(10 g) = 0.279 mW/g

Maximum value of SAR (measured) = 0.470 mW/g

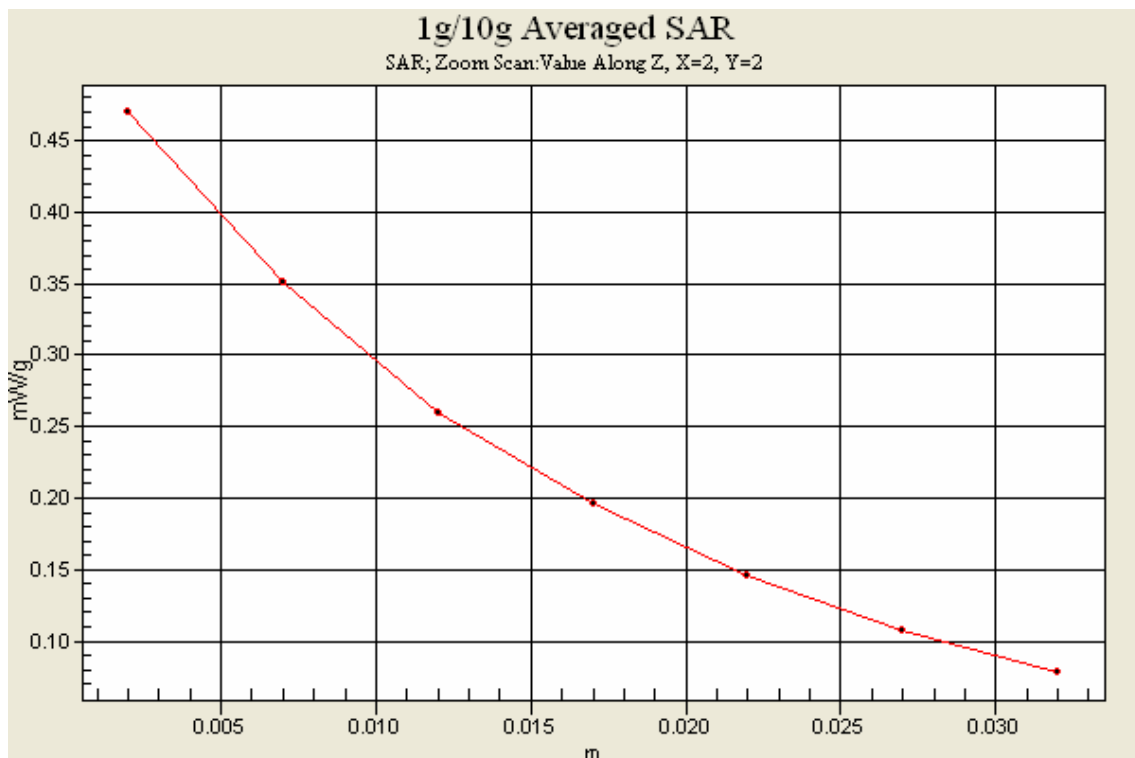

DUT: GT-S3770Y; Serial: FI-320-E

Program Name: GT-S3770Y GSM1900 Right (Job No. : FI-320)

Procedure Name: Cheek/Touch, Ch.661, Ant.Intenna, Bat.Standard

Meas. Ambient Temp(celsius)-23.0,Tissue Temp(celsius)-22.8;Test Date-12/Jan/2012

Communication System: GSM 1900; ;Duty Cycle: 1:8.3

Medium parameters used: $f = 1880$ MHz; $\sigma = 1.4$ mho/m; $\epsilon_r = 38.8$; $\rho = 1000$ kg/m³

Phantom section: Right Section

DASY4 Configuration:

- Probe: ES3DV2 - SN3017; ConvF(5.03, 5.03, 5.03); Calibrated: 2011-05-20

- Sensor-Surface: 4mm (Mechanical Surface Detection)

- Electronics: DAE4 Sn468; Calibrated: 2011-05-13

- Phantom: PHANTOM #2; Type: SAM; Serial: TP-1604

- Measurement SW: DASY4, V4.7 Build 80; Postprocessing SW: SEMCAD, V1.8 Build 184

Cheek/Touch, Ch.661, Ant.Intenna, Bat.Standard/Area Scan (51x71x1): Measurement grid:

dx=20mm, dy=20mm

Maximum value of SAR (interpolated) = 0.972 mW/g

Cheek/Touch, Ch.661, Ant.Intenna, Bat.Standard/Zoom Scan (5x5x7)/Cube 0:

Measurement grid: dx=8mm, dy=8mm, dz=5mm

Reference Value = 18.3 V/m; Power Drift = 0.078 dB

Peak SAR (extrapolated) = 1.33 W/kg

SAR(1 g) = 0.755 mW/g; SAR(10 g) = 0.390 mW/g

Maximum value of SAR (measured) = 0.794 mW/g

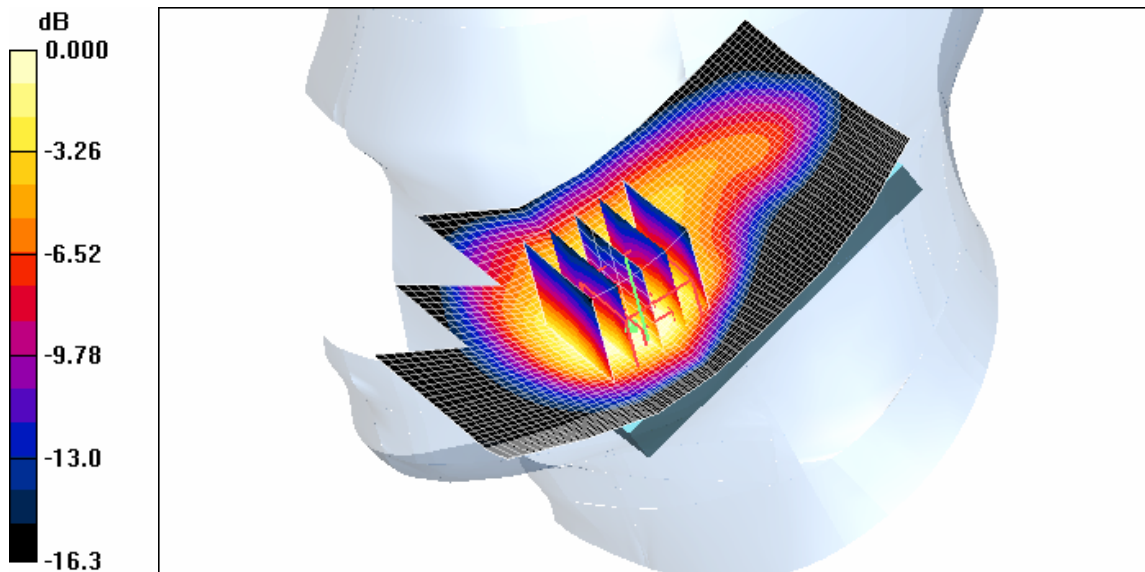

0 dB = 0.794mW/g

DUT: GT-S3770Y; Serial: FI-320-E

Program Name: GT-S3770Y GSM1900 Right (Job No. : FI-320)

Procedure Name: Ear/Tilt, Ch.661, Ant.Intenna, Bat.Standard

Meas. Ambient Temp(celsius)-23.0,Tissue Temp(celsius)-22.8;Test Date-12/Jan/2012

Communication System: GSM 1900; ;Duty Cycle: 1:8.3

Medium parameters used: $f = 1880$ MHz; $\sigma = 1.4$ mho/m; $\epsilon_r = 38.8$; $\rho = 1000$ kg/m³

Phantom section: Right Section

DASY4 Configuration:

- Probe: ES3DV2 - SN3017; ConvF(5.03, 5.03, 5.03); Calibrated: 2011-05-20

- Sensor-Surface: 4mm (Mechanical Surface Detection)

- Electronics: DAE4 Sn468; Calibrated: 2011-05-13

- Phantom: PHANTOM #2; Type: SAM; Serial: TP-1604

- Measurement SW: DASY4, V4.7 Build 80; Postprocessing SW: SEMCAD, V1.8 Build 184

Ear/Tilt, Ch.661, Ant.Intenna, Bat.Standard/Area Scan (51x71x1): Measurement grid:

dx=20mm, dy=20mm

Maximum value of SAR (interpolated) = 0.285 mW/g

Ear/Tilt, Ch.661, Ant.Intenna, Bat.Standard/Zoom Scan (5x5x7)/Cube 0: Measurement grid:

dx=8mm, dy=8mm, dz=5mm

Reference Value = 12.2 V/m; Power Drift = 0.138 dB

Peak SAR (extrapolated) = 0.405 W/kg

SAR(1 g) = 0.253 mW/g; SAR(10 g) = 0.146 mW/g

Maximum value of SAR (measured) = 0.273 mW/g

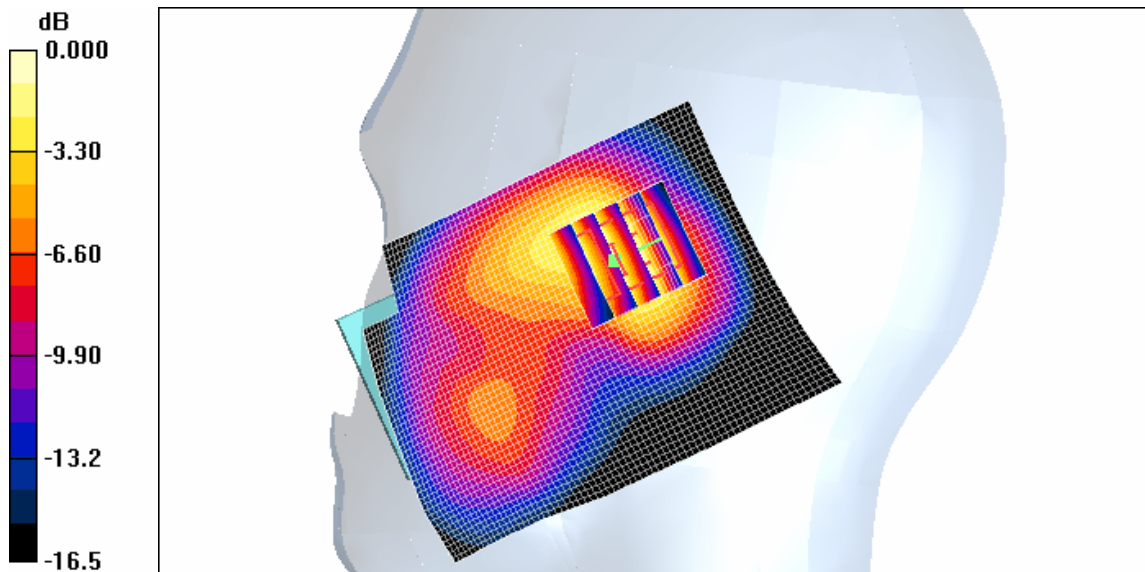

0 dB = 0.273mW/g

DUT: GT-S3770Y; Serial: FI-320-E

Program Name: GT-S3770Y GSM1900 Left (Job No. : FI-320)

Procedure Name: Cheek/Touch, Ch.661, Ant.Intenna, Bat.Standard

Meas. Ambient Temp(celsius)-23.0,Tissue Temp(celsius)-22.8;Test Date-12/Jan/2012

Communication System: GSM 1900; ;Duty Cycle: 1:8.3

Medium parameters used: $f = 1880$ MHz; $\sigma = 1.4$ mho/m; $\epsilon_r = 38.8$; $\rho = 1000$ kg/m³

Phantom section: Left Section

DASY4 Configuration:

- Probe: ES3DV2 - SN3017; ConvF(5.03, 5.03, 5.03); Calibrated: 2011-05-20

- Sensor-Surface: 4mm (Mechanical Surface Detection)

- Electronics: DAE4 Sn468; Calibrated: 2011-05-13

- Phantom: PHANTOM #2; Type: SAM; Serial: TP-1604

- Measurement SW: DASY4, V4.7 Build 80; Postprocessing SW: SEMCAD, V1.8 Build 184

Cheek/Touch, Ch.661, Ant.Intenna, Bat.Standard/Area Scan (51x71x1): Measurement grid:

dx=20mm, dy=20mm

Maximum value of SAR (interpolated) = 0.888 mW/g

Cheek/Touch, Ch.661, Ant.Intenna, Bat.Standard/Zoom Scan (5x5x7)/Cube 0:

Measurement grid: dx=8mm, dy=8mm, dz=5mm

Reference Value = 20.6 V/m; Power Drift = 0.167 dB

Peak SAR (extrapolated) = 1.17 W/kg

SAR(1 g) = 0.728 mW/g; SAR(10 g) = 0.409 mW/g

Maximum value of SAR (measured) = 0.753 mW/g

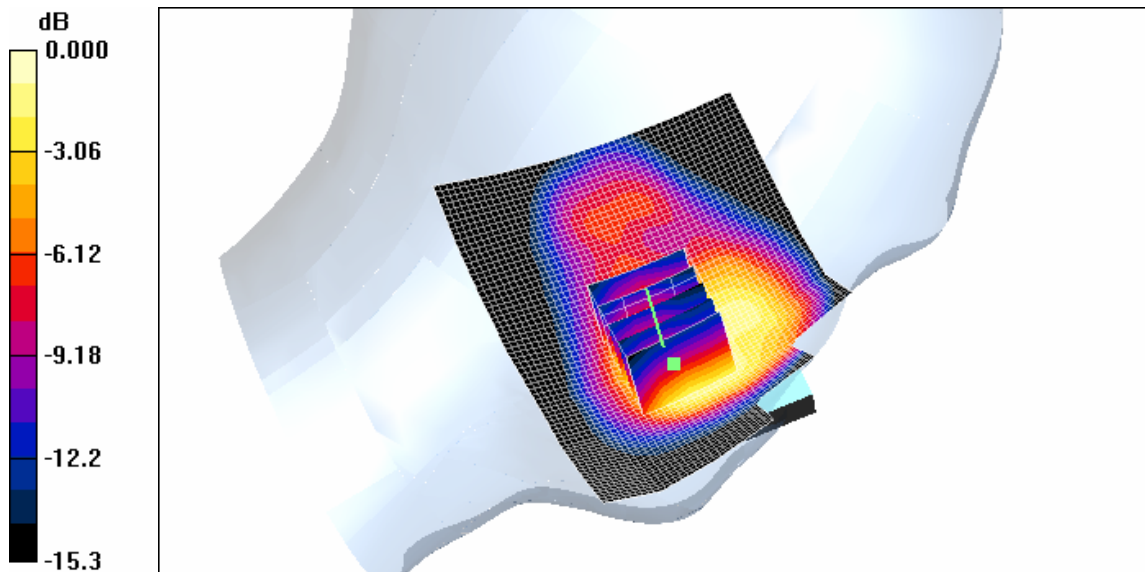

0 dB = 0.753mW/g

DUT: GT-S3770Y; Serial: FI-320-E

Program Name: GT-S3770Y GSM1900 Left (Job No. : FI-320)

Procedure Name: Ear/Tilt, Ch.661, Ant.Intenna, Bat.Standard

Meas. Ambient Temp(celsius)-23.0,Tissue Temp(celsius)-22.8;Test Date-12/Jan/2012

Communication System: GSM 1900; ;Duty Cycle: 1:8.3

Medium parameters used: $f = 1880$ MHz; $\sigma = 1.4$ mho/m; $\epsilon_r = 38.8$; $\rho = 1000$ kg/m³

Phantom section: Left Section

DASY4 Configuration:

- Probe: ES3DV2 - SN3017; ConvF(5.03, 5.03, 5.03); Calibrated: 2011-05-20

- Sensor-Surface: 4mm (Mechanical Surface Detection)

- Electronics: DAE4 Sn468; Calibrated: 2011-05-13

- Phantom: PHANTOM #2; Type: SAM; Serial: TP-1604

- Measurement SW: DASY4, V4.7 Build 80; Postprocessing SW: SEMCAD, V1.8 Build 184

Ear/Tilt, Ch.661, Ant.Intenna, Bat.Standard/Area Scan (51x71x1): Measurement grid:

dx=20mm, dy=20mm

Maximum value of SAR (interpolated) = 0.256 mW/g

Ear/Tilt, Ch.661, Ant.Intenna, Bat.Standard/Zoom Scan (5x5x7)/Cube 0: Measurement grid:

dx=8mm, dy=8mm, dz=5mm

Reference Value = 12.4 V/m; Power Drift = 0.016 dB

Peak SAR (extrapolated) = 0.374 W/kg

SAR(1 g) = 0.231 mW/g; SAR(10 g) = 0.131 mW/g

Maximum value of SAR (measured) = 0.256 mW/g

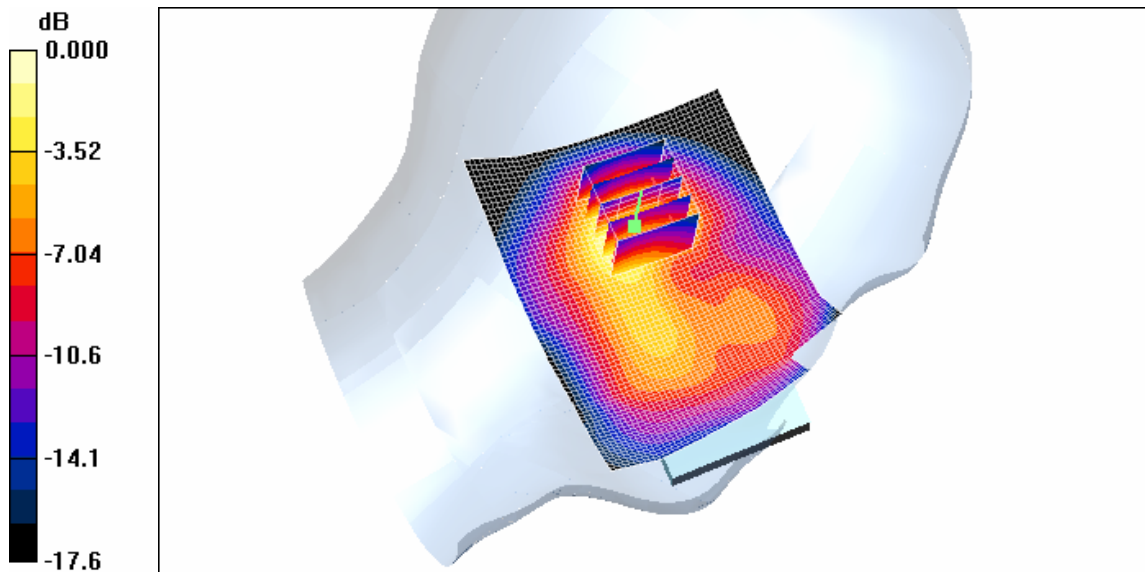

DUT: GT-S3770Y; Serial: FI-320-E

Program Name: GT-S3770Y GSM1900 Right (Job No. : FI-320)

Procedure Name: Cheek/Touch, Ch.661, Ant.Intenna, Bat.Standard

Meas. Ambient Temp(celsius)-23.0,Tissue Temp(celsius)-22.8;Test Date-12/Jan/2012

Communication System: GSM 1900; Frequency: 1880 MHz;Duty Cycle: 1:8.3

Medium parameters used: f = 1880 MHz; σ = 1.4 mho/m; ϵ_r = 38.8; ρ = 1000 kg/m³

Phantom section: Right Section

DASY4 Configuration:

- Probe: ES3DV2 - SN3017; ConvF(5.03, 5.03, 5.03); Calibrated: 2011-05-20

- Sensor-Surface: 4mm (Mechanical Surface Detection)

- Electronics: DAE4 Sn468; Calibrated: 2011-05-13

- Phantom: PHANTOM #2; Type: SAM; Serial: TP-1604

- Measurement SW: DASY4, V4.7 Build 80; Postprocessing SW: SEMCAD, V1.8 Build 184

Cheek/Touch, Ch.661, Ant.Intenna, Bat.Standard/Area Scan (51x71x1): Measurement grid:

dx=20mm, dy=20mm

Maximum value of SAR (interpolated) = 0.972 mW/g

Cheek/Touch, Ch.661, Ant.Intenna, Bat.Standard/Zoom Scan (5x5x7)/Cube 0:

Measurement grid: dx=8mm, dy=8mm, dz=5mm

Reference Value = 18.3 V/m; Power Drift = 0.078 dB

Peak SAR (extrapolated) = 1.33 W/kg

SAR(1 g) = 0.755 mW/g; SAR(10 g) = 0.390 mW/g

Maximum value of SAR (measured) = 0.794 mW/g

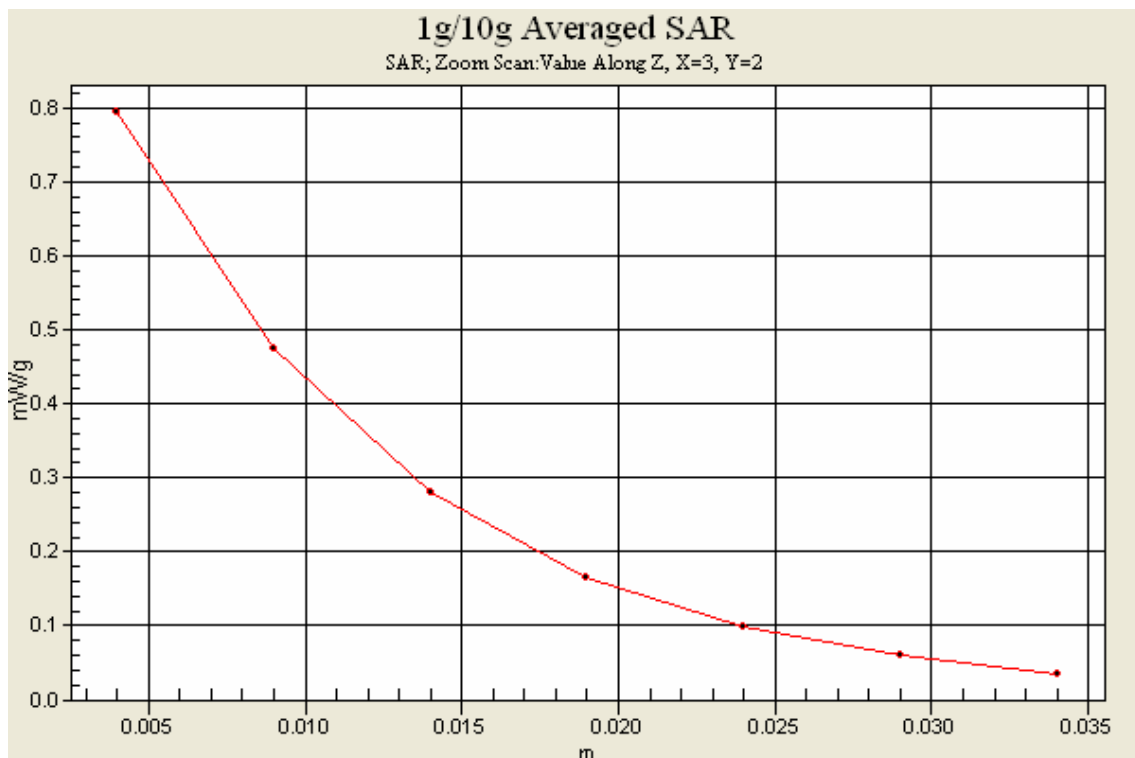

DUT: GT-S3770Y; Serial: FI-320-E

Program Name: GT-S3770Y GPRS1900 Body (Job No. : FI-320)

Procedure Name: Body, Ch.661, Ant.Intenna, Bat.Standard, Back, 2Tx, 15mm

Meas. Ambient Temp(celsius)-23.0,Tissue Temp(celsius)-22.8;Test Date-12/Jan/2012

Communication System: Body GPRS ; ;Duty Cycle: 1:4.15

Medium parameters used: $f = 1880$ MHz; $\sigma = 1.54$ mho/m; $\epsilon_r = 52.6$; $\rho = 1000$ kg/m³

Phantom section: Right Section

DASY4 Configuration:

- Probe: EX3DV4 - SN3750; ConvF(7.12, 7.12, 7.12); Calibrated: 2011-04-14
- Sensor-Surface: 4mm (Mechanical Surface Detection)
- Electronics: DAE4 Sn533; Calibrated: 2011-09-21
- Phantom: Triple Flat Phantom 5.1; Type: Triple Flat Phantom 5.1; Serial: 1001
- Measurement SW: DASY4, V4.7 Build 80; Postprocessing SW: SEMCAD, V1.8 Build 184

Body, Ch.661, Ant.Intenna, Bat.Standard, Back, 2Tx, 15mm/Area Scan (51x71x1):

Measurement grid: dx=20mm, dy=20mm

Maximum value of SAR (interpolated) = 0.433 mW/g

Body, Ch.661, Ant.Intenna, Bat.Standard, Back, 2Tx, 15mm/Zoom Scan (5x5x7)/Cube 0:

Measurement grid: dx=8mm, dy=8mm, dz=5mm

Reference Value = 14.5 V/m; Power Drift = 0.164 dB

Peak SAR (extrapolated) = 0.600 W/kg

SAR(1 g) = 0.392 mW/g; SAR(10 g) = 0.247 mW/g

Maximum value of SAR (measured) = 0.426 mW/g

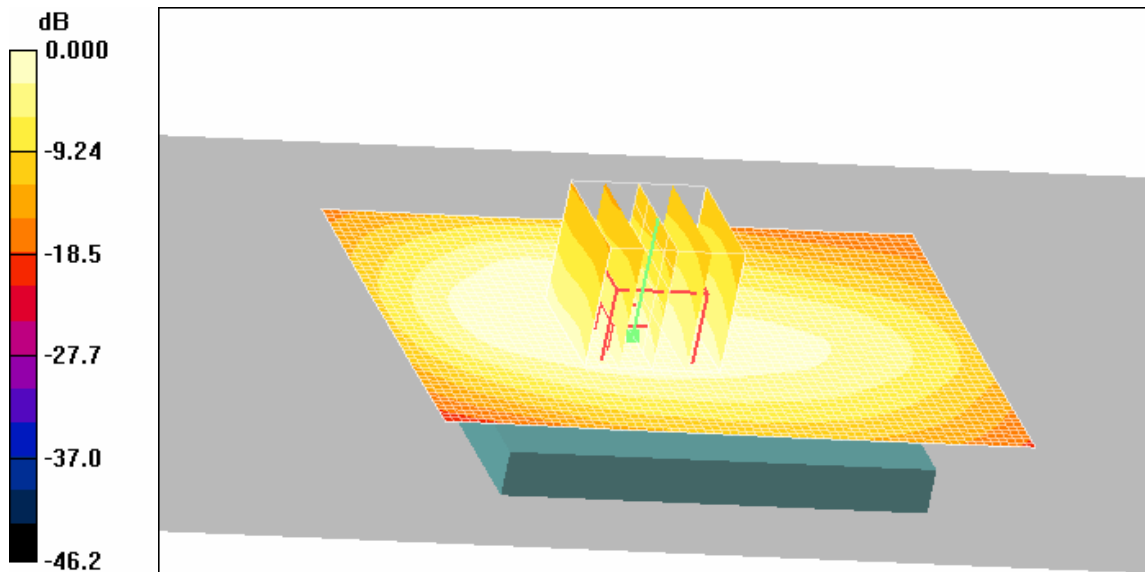

0 dB = 0.426mW/g

DUT: GT-S3770Y; Serial: FI-320-E

Program Name: GT-S3770Y GPRS1900 Body (Job No. : FI-320)

Procedure Name: Body, Ch.661, Ant.Intenna, Bat.Standard, Back, 3Tx, 15mm

Meas. Ambient Temp(celsius)-23.0,Tissue Temp(celsius)-22.8;Test Date-12/Jan/2012

Communication System: Body GPRS ; ;Duty Cycle: 1:2.767

Medium parameters used: $f = 1880$ MHz; $\sigma = 1.54$ mho/m; $\epsilon_r = 52.6$; $\rho = 1000$ kg/m³

Phantom section: Right Section

DASY4 Configuration:

- Probe: EX3DV4 - SN3750; ConvF(7.12, 7.12, 7.12); Calibrated: 2011-04-14

- Sensor-Surface: 4mm (Mechanical Surface Detection)

- Electronics: DAE4 Sn533; Calibrated: 2011-09-21

- Phantom: Triple Flat Phantom 5.1; Type: Triple Flat Phantom 5.1; Serial: 1001

- Measurement SW: DASY4, V4.7 Build 80; Postprocessing SW: SEMCAD, V1.8 Build 184

Body, Ch.661, Ant.Intenna, Bat.Standard, Back, 3Tx, 15mm/Area Scan (51x71x1):

Measurement grid: dx=20mm, dy=20mm

Maximum value of SAR (interpolated) = 0.441 mW/g

Body, Ch.661, Ant.Intenna, Bat.Standard, Back, 3Tx, 15mm/Zoom Scan (5x5x7)/Cube 0:

Measurement grid: dx=8mm, dy=8mm, dz=5mm

Reference Value = 14.8 V/m; Power Drift = 0.100 dB

Peak SAR (extrapolated) = 0.643 W/kg

SAR(1 g) = 0.405 mW/g; SAR(10 g) = 0.255 mW/g

Maximum value of SAR (measured) = 0.437 mW/g

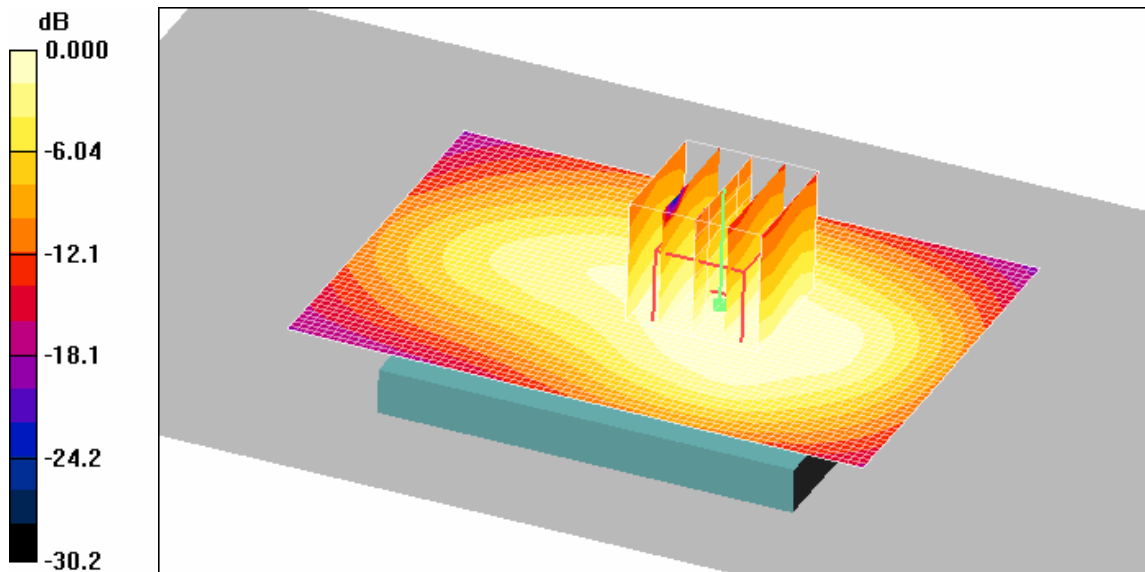

0 dB = 0.437mW/g

DUT: GT-S3770Y; Serial: FI-320-E

Program Name: GT-S3770Y GPRS1900 Body (Job No. : FI-320)

Procedure Name: Body, Ch.661, Ant.Intenna, Bat.Standard, Back, 4Tx, 15mm

Meas. Ambient Temp(celsius)-23.0,Tissue Temp(celsius)-22.8;Test Date-12/Jan/2012

Communication System: Body GPRS ; ;Duty Cycle: 1:2.075

Medium parameters used: $f = 1880$ MHz; $\sigma = 1.54$ mho/m; $\epsilon_r = 52.6$; $\rho = 1000$ kg/m³

Phantom section: Right Section

DASY4 Configuration:

- Probe: EX3DV4 - SN3750; ConvF(7.12, 7.12, 7.12); Calibrated: 2011-04-14
- Sensor-Surface: 4mm (Mechanical Surface Detection)
- Electronics: DAE4 Sn533; Calibrated: 2011-09-21
- Phantom: Triple Flat Phantom 5.1; Type: Triple Flat Phantom 5.1; Serial: 1001
- Measurement SW: DASY4, V4.7 Build 80; Postprocessing SW: SEMCAD, V1.8 Build 184

Body, Ch.661, Ant.Intenna, Bat.Standard, Back, 4Tx, 15mm/Area Scan (51x71x1):

Measurement grid: dx=20mm, dy=20mm

Maximum value of SAR (interpolated) = 0.386 mW/g

Body, Ch.661, Ant.Intenna, Bat.Standard, Back, 4Tx, 15mm/Zoom Scan (5x5x7)/Cube 0:

Measurement grid: dx=8mm, dy=8mm, dz=5mm

Reference Value = 14.1 V/m; Power Drift = -0.032 dB

Peak SAR (extrapolated) = 0.555 W/kg

SAR(1 g) = 0.356 mW/g; SAR(10 g) = 0.224 mW/g

Maximum value of SAR (measured) = 0.378 mW/g

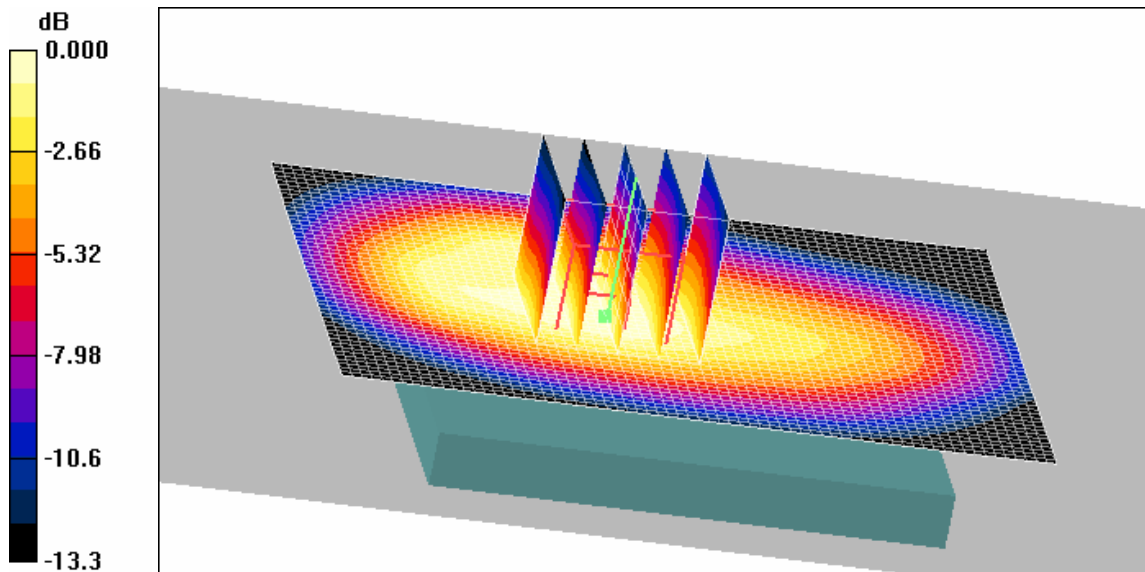

0 dB = 0.378mW/g

DUT: GT-S3770Y; Serial: FI-320-E

Program Name: GT-S3770Y GPRS1900 Body (Job No. : FI-320)

Procedure Name: Body, Ch.661, Ant.Intenna, Bat.Standard, Back, 3Tx, 15mm

Meas. Ambient Temp(celsius)-23.0,Tissue Temp(celsius)-22.8;Test Date-12/Jan/2012

Communication System: Body GPRS ; Frequency: 1880 MHz;Duty Cycle: 1:2.767

Medium parameters used: f = 1880 MHz; σ = 1.54 mho/m; ϵ_r = 52.6; ρ = 1000 kg/m³

Phantom section: Right Section

DASY4 Configuration:

- Probe: EX3DV4 - SN3750; ConvF(7.12, 7.12, 7.12); Calibrated: 2011-04-14

- Sensor-Surface: 4mm (Mechanical Surface Detection)

- Electronics: DAE4 Sn533; Calibrated: 2011-09-21

- Phantom: Triple Flat Phantom 5.1; Type: Triple Flat Phantom 5.1; Serial: 1001

- Measurement SW: DASY4, V4.7 Build 80; Postprocessing SW: SEMCAD, V1.8 Build 184

Body, Ch.661, Ant.Intenna, Bat.Standard, Back, 3Tx, 15mm/Area Scan (51x71x1):

Measurement grid: dx=20mm, dy=20mm

Maximum value of SAR (interpolated) = 0.441 mW/g

Body, Ch.661, Ant.Intenna, Bat.Standard, Back, 3Tx, 15mm/Zoom Scan (5x5x7)/Cube 0:

Measurement grid: dx=8mm, dy=8mm, dz=5mm

Reference Value = 14.8 V/m; Power Drift = 0.100 dB

Peak SAR (extrapolated) = 0.643 W/kg

SAR(1 g) = 0.405 mW/g; SAR(10 g) = 0.255 mW/g

Maximum value of SAR (measured) = 0.437 mW/g

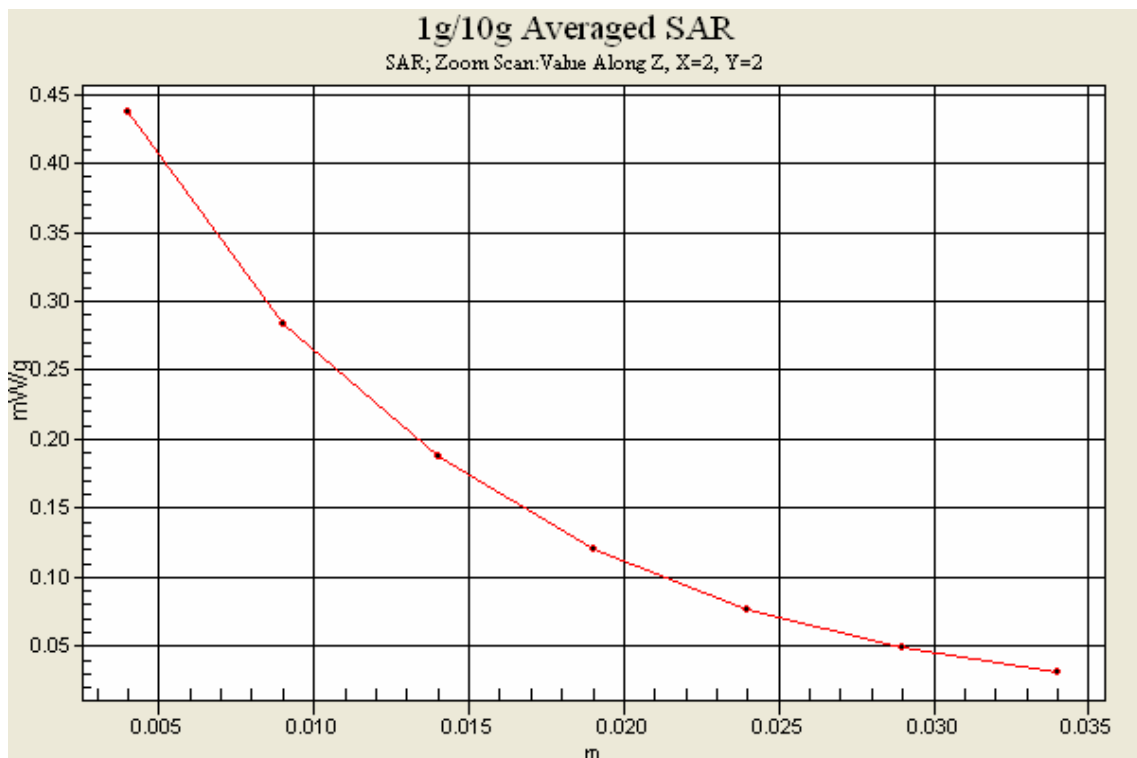

DUT: GT-S3770Y; Serial: FI-320-E

Program Name: GT-S3770Y WLAN Right(Job No. : FI-320)

Procedure Name: Cheek/Touch, Ch.01, Ant.Intenna, Bat.Standard, 1Mbps

Meas. Ambient Temp(celsius)-22.7,Tissue Temp(celsius)-22.6;Test Date-13/Jan/2012

Communication System: WLAN; ;Duty Cycle: 1:1

Medium parameters used: $f = 2412$ MHz; $\sigma = 1.85$ mho/m; $\epsilon_r = 38.6$; $\rho = 1000$ kg/m³

Phantom section: Right Section

DASY4 Configuration:

- Probe: ES3DV2 - SN3017; ConvF(4.28, 4.28, 4.28); Calibrated: 2011-05-20
- Sensor-Surface: 4mm (Mechanical Surface Detection)
- Electronics: DAE4 Sn468; Calibrated: 2011-05-13
- Phantom: PHANTOM #2; Type: SAM; Serial: TP-1604
- Measurement SW: DASY4, V4.7 Build 80; Postprocessing SW: SEMCAD, V1.8 Build 184

Cheek/Touch, Ch.01, Ant.Intenna, Bat.Standard, 1Mbps/Area Scan (51x71x1):

Measurement grid: dx=20mm, dy=20mm

Maximum value of SAR (interpolated) = 0.198 mW/g

Cheek/Touch, Ch.01, Ant.Intenna, Bat.Standard, 1Mbps/Zoom Scan (5x5x7)/Cube 0:

Measurement grid: dx=8mm, dy=8mm, dz=5mm

Reference Value = 8.29 V/m; Power Drift = 0.175 dB

Peak SAR (extrapolated) = 0.407 W/kg

SAR(1 g) = 0.210 mW/g; SAR(10 g) = 0.104 mW/g

Maximum value of SAR (measured) = 0.240 mW/g

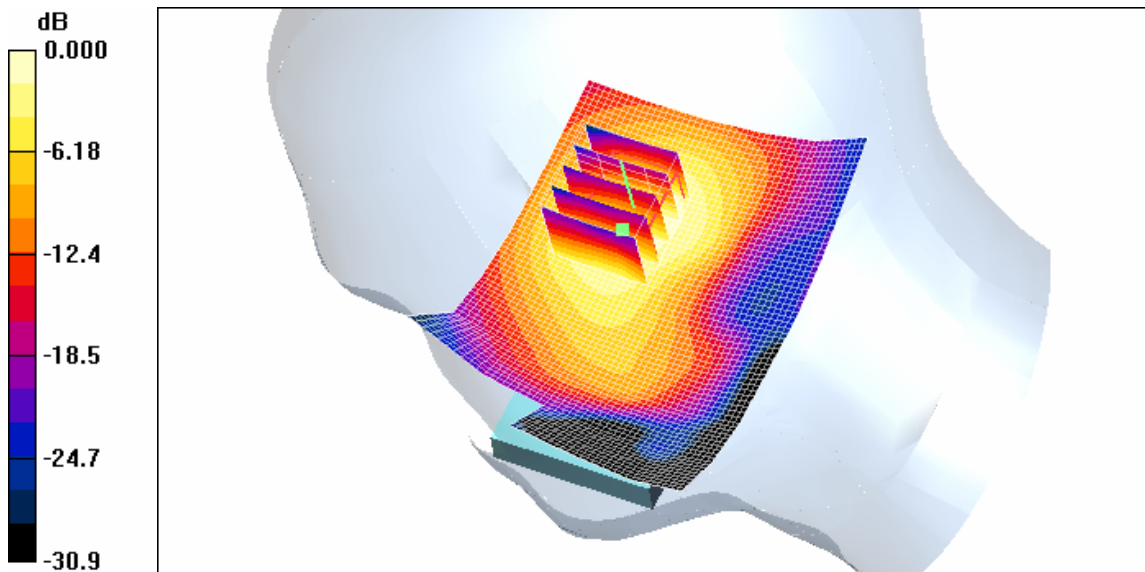

0 dB = 0.240mW/g

DUT: GT-S3770Y; Serial: FI-320-E

Program Name: GT-S3770Y WLAN Right(Job No. : FI-320)

Procedure Name: Ear/Tilt, Ch.01, Ant.Intenna, Bat.Standard, 1Mbps

Meas. Ambient Temp(celsius)-22.7,Tissue Temp(celsius)-22.6;Test Date-13/Jan/2012

Communication System: WLAN; ;Duty Cycle: 1:1

Medium parameters used: $f = 2412$ MHz; $\sigma = 1.85$ mho/m; $\epsilon_r = 38.6$; $\rho = 1000$ kg/m³

Phantom section: Right Section

DASY4 Configuration:

- Probe: ES3DV2 - SN3017; ConvF(4.28, 4.28, 4.28); Calibrated: 2011-05-20

- Sensor-Surface: 4mm (Mechanical Surface Detection)

- Electronics: DAE4 Sn468; Calibrated: 2011-05-13

- Phantom: PHANTOM #2; Type: SAM; Serial: TP-1604

- Measurement SW: DASY4, V4.7 Build 80; Postprocessing SW: SEMCAD, V1.8 Build 184

Ear/Tilt, Ch.01, Ant.Intenna, Bat.Standard, 1Mbps/Area Scan (51x71x1): Measurement grid:

dx=20mm, dy=20mm

Maximum value of SAR (interpolated) = 0.212 mW/g

Ear/Tilt, Ch.01, Ant.Intenna, Bat.Standard, 1Mbps/Zoom Scan (5x5x7)/Cube 0:

Measurement grid: dx=8mm, dy=8mm, dz=5mm

Reference Value = 10.3 V/m; Power Drift = -0.174 dB

Peak SAR (extrapolated) = 0.363 W/kg

SAR(1 g) = 0.182 mW/g; SAR(10 g) = 0.095 mW/g

Maximum value of SAR (measured) = 0.196 mW/g

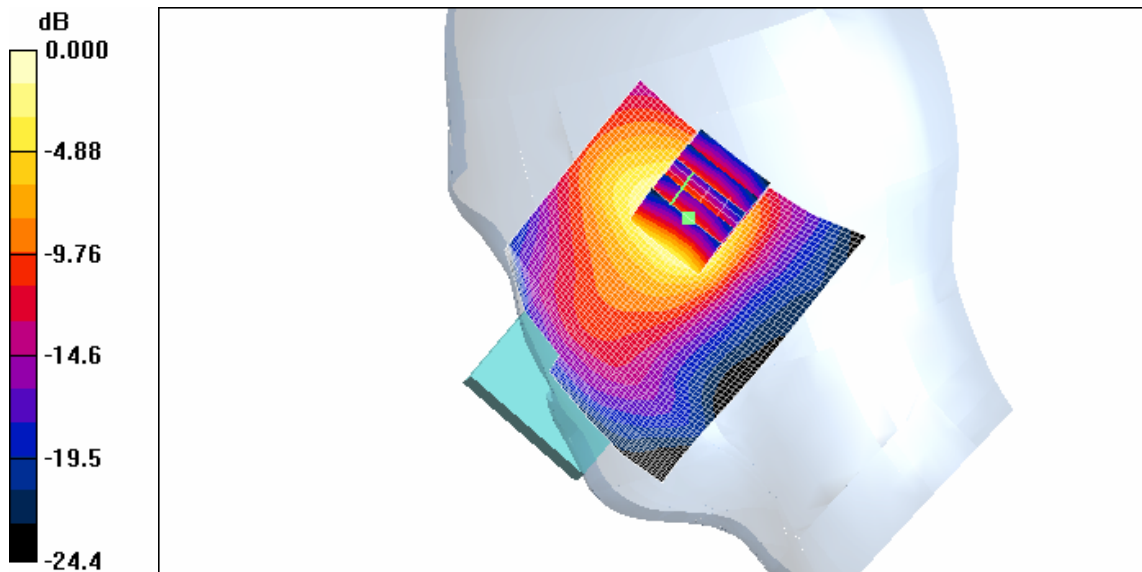

0 dB = 0.196mW/g

DUT: GT-S3770Y; Serial: FI-320-E

Program Name: GT-S3770Y WLAN Left(Job No. : FI-320)

Procedure Name: Cheek/Touch, Ch.01, Ant.Intenna, Bat.Standard, 1Mbps

Meas. Ambient Temp(celsius)-22.7,Tissue Temp(celsius)-22.6;Test Date-13/Jan/2012

Communication System: WLAN; ;Duty Cycle: 1:1

Medium parameters used: $f = 2412$ MHz; $\sigma = 1.85$ mho/m; $\epsilon_r = 38.6$; $\rho = 1000$ kg/m³

Phantom section: Left Section

DASY4 Configuration:

- Probe: ES3DV2 - SN3017; ConvF(4.28, 4.28, 4.28); Calibrated: 2011-05-20
- Sensor-Surface: 4mm (Mechanical Surface Detection)
- Electronics: DAE4 Sn468; Calibrated: 2011-05-13
- Phantom: PHANTOM #2; Type: SAM; Serial: TP-1604
- Measurement SW: DASY4, V4.7 Build 80; Postprocessing SW: SEMCAD, V1.8 Build 184

Cheek/Touch, Ch.01, Ant.Intenna, Bat.Standard, 1Mbps/Area Scan (51x71x1):

Measurement grid: dx=20mm, dy=20mm

Maximum value of SAR (interpolated) = 0.245 mW/g

Cheek/Touch, Ch.01, Ant.Intenna, Bat.Standard, 1Mbps/Zoom Scan (5x5x7)/Cube 0:

Measurement grid: dx=8mm, dy=8mm, dz=5mm

Reference Value = 10.0 V/m; Power Drift = -0.004 dB

Peak SAR (extrapolated) = 0.380 W/kg

SAR(1 g) = 0.182 mW/g; SAR(10 g) = 0.096 mW/g

Maximum value of SAR (measured) = 0.197 mW/g

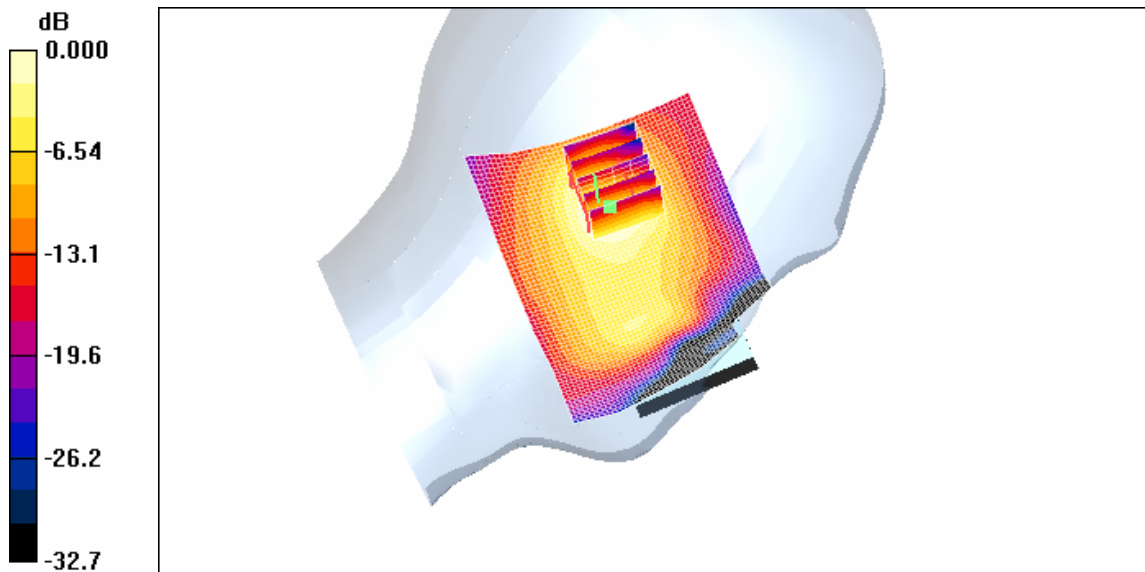

DUT: GT-S3770Y; Serial: FI-320-E

Program Name: GT-S3770Y WLAN Left(Job No. : FI-320)

Procedure Name: Ear/Tilt, Ch.01, Ant.Intenna, Bat.Standard, 1Mbps

Meas. Ambient Temp(celsius)-22.7,Tissue Temp(celsius)-22.6;Test Date-13/Jan/2012

Communication System: WLAN; ;Duty Cycle: 1:1

Medium parameters used: $f = 2412$ MHz; $\sigma = 1.85$ mho/m; $\epsilon_r = 38.6$; $\rho = 1000$ kg/m³

Phantom section: Left Section

DASY4 Configuration:

- Probe: ES3DV2 - SN3017; ConvF(4.28, 4.28, 4.28); Calibrated: 2011-05-20
- Sensor-Surface: 4mm (Mechanical Surface Detection)
- Electronics: DAE4 Sn468; Calibrated: 2011-05-13
- Phantom: PHANTOM #2; Type: SAM; Serial: TP-1604
- Measurement SW: DASY4, V4.7 Build 80; Postprocessing SW: SEMCAD, V1.8 Build 184

Ear/Tilt, Ch.01, Ant.Intenna, Bat.Standard, 1Mbps/Area Scan (51x71x1): Measurement grid:

dx=20mm, dy=20mm

Maximum value of SAR (interpolated) = 0.259 mW/g

Ear/Tilt, Ch.01, Ant.Intenna, Bat.Standard, 1Mbps/Zoom Scan (5x5x7)/Cube 0:

Measurement grid: dx=8mm, dy=8mm, dz=5mm

Reference Value = 11.1 V/m; Power Drift = 0.035 dB

Peak SAR (extrapolated) = 0.429 W/kg

SAR(1 g) = 0.206 mW/g; SAR(10 g) = 0.102 mW/g

Maximum value of SAR (measured) = 0.221 mW/g

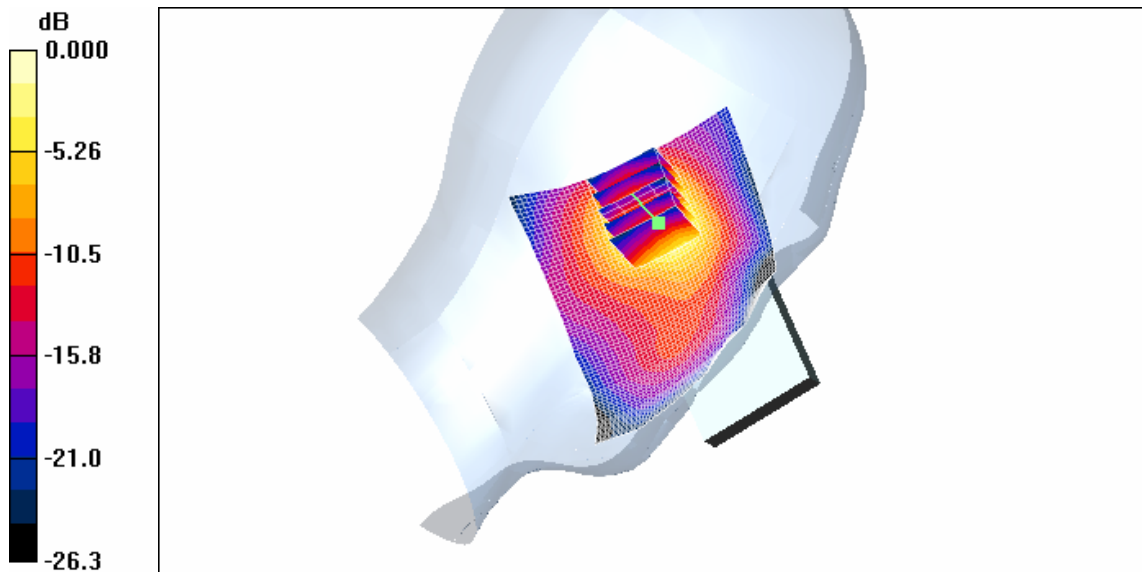

0 dB = 0.221mW/g

DUT: GT-S3770Y; Serial: FI-320-E

Program Name: GT-S3770Y WLAN Right(Job No. : FI-320)

Procedure Name: Cheek/Touch, Ch.01, Ant.Intenna, Bat.Standard, 1Mbps

Meas. Ambient Temp(celsius)-22.7,Tissue Temp(celsius)-22.6;Test Date-13/Jan/2012

Communication System: WLAN; Frequency: 2412 MHz;Duty Cycle: 1:1

Medium parameters used: f = 2412 MHz; σ = 1.85 mho/m; ϵ_r = 38.6; ρ = 1000 kg/m³

Phantom section: Right Section

DASY4 Configuration:

- Probe: ES3DV2 - SN3017; ConvF(4.28, 4.28, 4.28); Calibrated: 2011-05-20
- Sensor-Surface: 4mm (Mechanical Surface Detection)
- Electronics: DAE4 Sn468; Calibrated: 2011-05-13
- Phantom: PHANTOM #2; Type: SAM; Serial: TP-1604
- Measurement SW: DASY4, V4.7 Build 80; Postprocessing SW: SEMCAD, V1.8 Build 184

Cheek/Touch, Ch.01, Ant.Intenna, Bat.Standard, 1Mbps/Area Scan (51x71x1):

Measurement grid: dx=20mm, dy=20mm

Maximum value of SAR (interpolated) = 0.198 mW/g

Cheek/Touch, Ch.01, Ant.Intenna, Bat.Standard, 1Mbps/Zoom Scan (5x5x7)/Cube 0:

Measurement grid: dx=8mm, dy=8mm, dz=5mm

Reference Value = 8.29 V/m; Power Drift = 0.175 dB

Peak SAR (extrapolated) = 0.407 W/kg

SAR(1 g) = 0.210 mW/g; SAR(10 g) = 0.104 mW/g

Maximum value of SAR (measured) = 0.240 mW/g

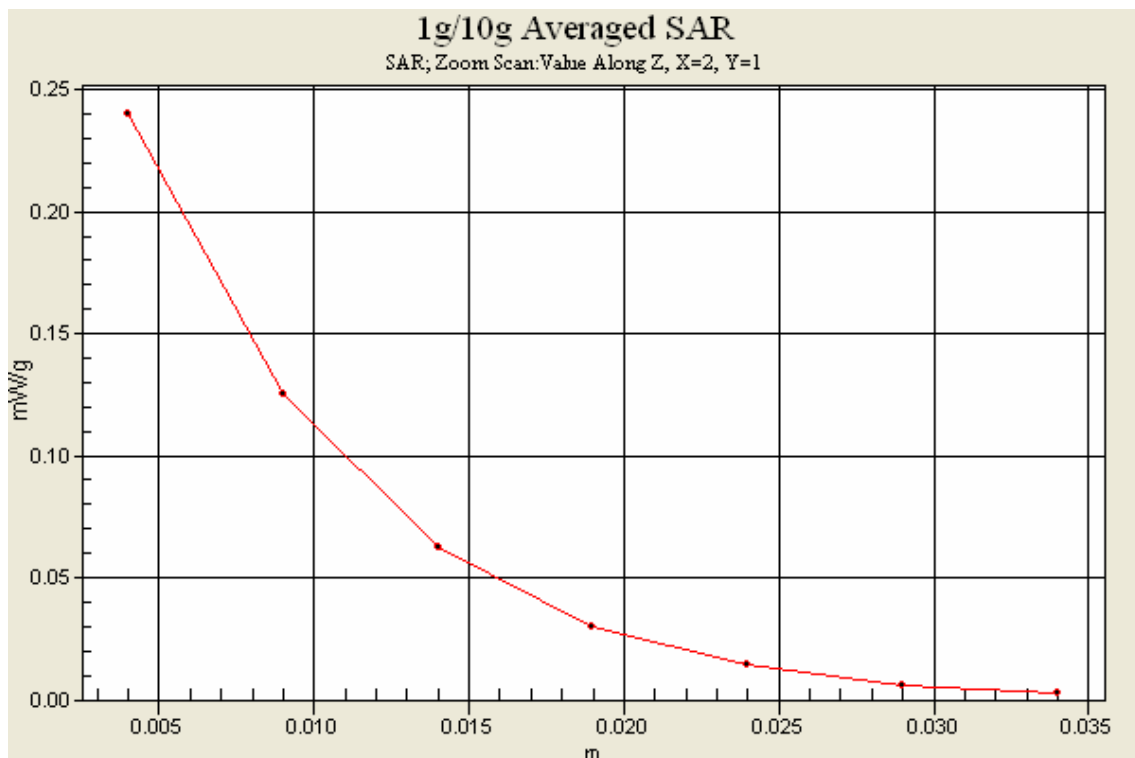

DUT: GT-S3770Y; Serial: FI-320-E

Program Name: GT-S3770Y WLAN Body (Job No. : FI-320)

Procedure Name: Body, Ch.06, Ant.Intenna, Bat.Standard, Back, 1Mbps, 15mm

Meas. Ambient Temp(celsius)-22.7,Tissue Temp(celsius)-22.6;Test Date-13/Jan/2012

Communication System: WLAN; Frequency: 2437 MHz;Duty Cycle: 1:1

Medium parameters used: $f = 2437$ MHz; $\sigma = 1.95$ mho/m; $\epsilon_r = 51.5$; $\rho = 1000$ kg/m³

Phantom section: Right Section

DASY4 Configuration:

- Probe: EX3DV4 - SN3750; ConvF(6.76, 6.76, 6.76); Calibrated: 2011-04-14

- Sensor-Surface: 4mm (Mechanical Surface Detection)

- Electronics: DAE4 Sn533; Calibrated: 2011-09-21

- Phantom: Triple Flat Phantom 5.1; Type: Triple Flat Phantom 5.1; Serial: 1001

- Measurement SW: DASY4, V4.7 Build 80; Postprocessing SW: SEMCAD, V1.8 Build 184

Body, Ch.06, Ant.Intenna, Bat.Standard, Back, 1Mbps, 15mm/Area Scan (51x71x1):

Measurement grid: dx=20mm, dy=20mm

Maximum value of SAR (interpolated) = 0.083 mW/g

Body, Ch.06, Ant.Intenna, Bat.Standard, Back, 1Mbps, 15mm/Zoom Scan (5x5x7)/Cube 0:

Measurement grid: dx=8mm, dy=8mm, dz=5mm

Reference Value = 3.90 V/m; Power Drift = 0.025 dB

Peak SAR (extrapolated) = 0.140 W/kg

SAR(1 g) = 0.080 mW/g; SAR(10 g) = 0.046 mW/g

Maximum value of SAR (measured) = 0.087 mW/g

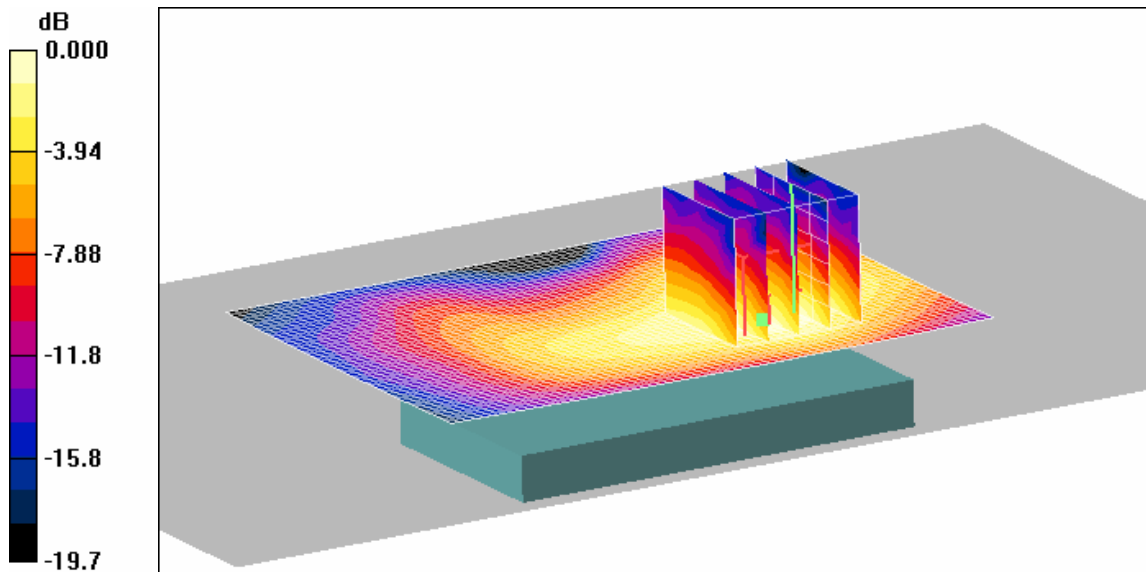

0 dB = 0.087mW/g

DUT: GT-S3770Y; Serial: FI-320-E

Program Name: GT-S3770Y WLAN Body (Job No. : FI-320)

Procedure Name: Body, Ch.06, Ant.Intenna, Bat.Standard, Back, 1Mbps, 15mm

Meas. Ambient Temp(celsius)-22.7,Tissue Temp(celsius)-22.6;Test Date-13/Jan/2012

Communication System: WLAN; Frequency: 2437 MHz;Duty Cycle: 1:1

Medium parameters used: $f = 2437$ MHz; $\sigma = 1.95$ mho/m; $\epsilon_r = 51.5$; $\rho = 1000$ kg/m³

Phantom section: Right Section

DASY4 Configuration:

- Probe: EX3DV4 - SN3750; ConvF(6.76, 6.76, 6.76); Calibrated: 2011-04-14
- Sensor-Surface: 4mm (Mechanical Surface Detection)
- Electronics: DAE4 Sn533; Calibrated: 2011-09-21
- Phantom: Triple Flat Phantom 5.1; Type: Triple Flat Phantom 5.1; Serial: 1001
- Measurement SW: DASY4, V4.7 Build 80; Postprocessing SW: SEMCAD, V1.8 Build 184

Body, Ch.06, Ant.Intenna, Bat.Standard, Back, 1Mbps, 15mm/Area Scan (51x71x1):

Measurement grid: dx=20mm, dy=20mm

Maximum value of SAR (interpolated) = 0.083 mW/g

Body, Ch.06, Ant.Intenna, Bat.Standard, Back, 1Mbps, 15mm/Zoom Scan (5x5x7)/Cube 0:

Measurement grid: dx=8mm, dy=8mm, dz=5mm

Reference Value = 3.90 V/m; Power Drift = 0.025 dB

Peak SAR (extrapolated) = 0.140 W/kg

SAR(1 g) = 0.080 mW/g; SAR(10 g) = 0.046 mW/g

Maximum value of SAR (measured) = 0.087 mW/g

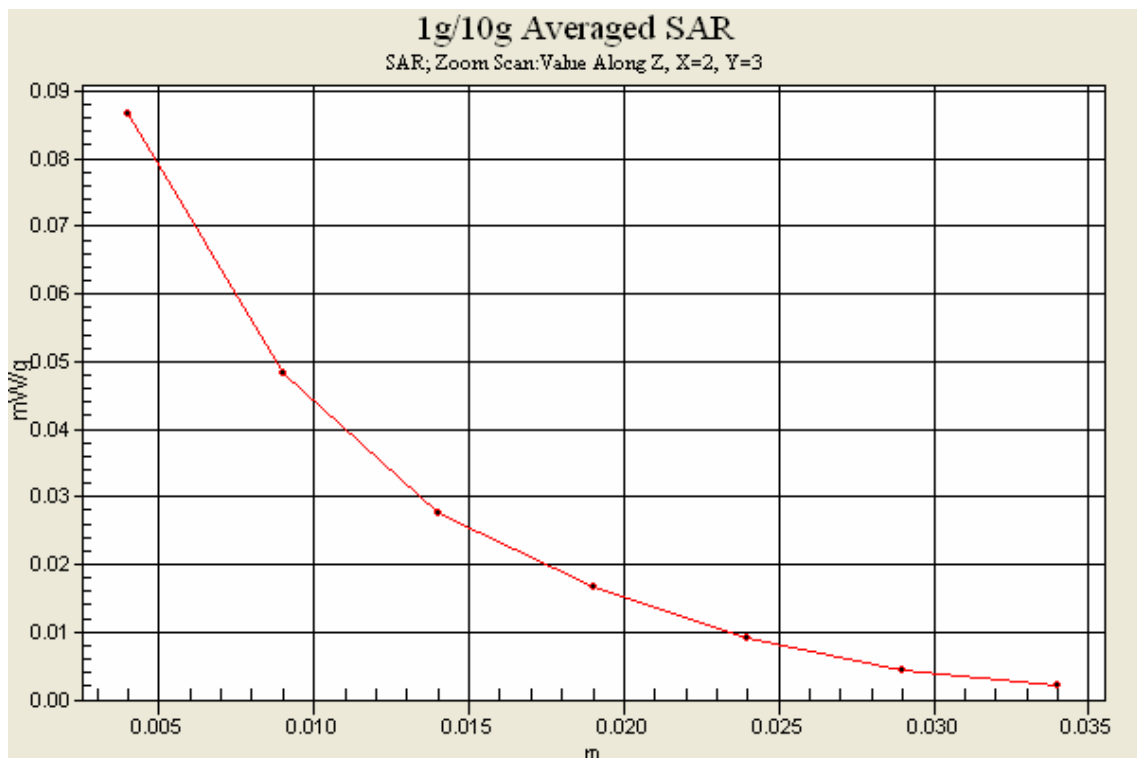

APPENDIX F

Probe Calibration



Accredited by the Swiss Accreditation Service (SAS)
The Swiss Accreditation Service is one of the signatories to the EA
Multilateral Agreement for the recognition of calibration certificates

Accreditation No.: **SCS 108**

Client **Samsung (Dymstec)**

Certificate No: **EX3-3750_Apr11**

CALIBRATION CERTIFICATE

Object **EX3DV4 - SN:3750**

Calibration procedure(s) **QA CAL-01.v7, QA CAL-14.v3, QA CAL-23.v4, QA CAL-25.v3
Calibration procedure for dosimetric E-field probes**

Calibration date: **April 14, 2011**

This calibration certificate documents the traceability to national standards, which realize the physical units of measurements (SI).
The measurements and the uncertainties with confidence probability are given on the following pages and are part of the certificate.

All calibrations have been conducted in the closed laboratory facility: environment temperature (22 ± 3)°C and humidity < 70%.

Calibration Equipment used (M&TE critical for calibration)

Primary Standards	ID	Cal Date (Certificate No.)	Scheduled Calibration
Power meter E4419B	GB41293874	31-Mar-11 (No. 217-01372)	Apr-12
Power sensor E4412A	MY41495277	31-Mar-11 (No. 217-01372)	Apr-12
Power sensor E4412A	MY41498087	31-Mar-11 (No. 217-01372)	Apr-12
Reference 3 dB Attenuator	SN: S5054 (3c)	29-Mar-11 (No. 217-01369)	Apr-12
Reference 20 dB Attenuator	SN: S5086 (20b)	29-Mar-11 (No. 217-01367)	Apr-12
Reference 30 dB Attenuator	SN: S5129 (30b)	29-Mar-11 (No. 217-01370)	Apr-12
Reference Probe ES3DV2	SN: 3013	29-Dec-10 (No. ES3-3013_Dec10)	Dec-11
DAE4	SN: 654	23-Apr-10 (No. DAE4-654_Apr10)	Apr-11
Secondary Standards	ID	Check Date (in house)	Scheduled Check
RF generator HP 8648C	US3642U01700	4-Aug-99 (in house check Oct-09)	In house check: Oct-11
Network Analyzer HP 8753E	US37390585	18-Oct-01 (in house check Oct-10)	In house check: Oct-11

	Name	Function	Signature
Calibrated by:	Katja Pokovic	Technical Manager	
Approved by:	Niels Kuster	Quality Manager	

Issued: April 14, 2011

This calibration certificate shall not be reproduced except in full without written approval of the laboratory.



Accredited by the Swiss Accreditation Service (SAS)

Accreditation No.: SCS 108

The Swiss Accreditation Service is one of the signatories to the EA
Multilateral Agreement for the recognition of calibration certificates

Glossary:

TSL	tissue simulating liquid
NORM _{x,y,z}	sensitivity in free space
ConvF	sensitivity in TSL / NORM _{x,y,z}
DCP	diode compression point
CF	crest factor (1/duty_cycle) of the RF signal
A, B, C	modulation dependent linearization parameters
Polarization φ	φ rotation around probe axis
Polarization ϑ	ϑ rotation around an axis that is in the plane normal to probe axis (at measurement center), i.e., $\vartheta = 0$ is normal to probe axis

Calibration is Performed According to the Following Standards:

- IEEE Std 1528-2003, "IEEE Recommended Practice for Determining the Peak Spatial-Averaged Specific Absorption Rate (SAR) in the Human Head from Wireless Communications Devices: Measurement Techniques", December 2003
- IEC 62209-1, "Procedure to measure the Specific Absorption Rate (SAR) for hand-held devices used in close proximity to the ear (frequency range of 300 MHz to 3 GHz)", February 2005

Methods Applied and Interpretation of Parameters:

- NORM_{x,y,z}**: Assessed for E-field polarization $\vartheta = 0$ ($f \leq 900$ MHz in TEM-cell; $f > 1800$ MHz: R22 waveguide). NORM_{x,y,z} are only intermediate values, i.e., the uncertainties of NORM_{x,y,z} does not affect the E²-field uncertainty inside TSL (see below ConvF).
- NORM(f)_{x,y,z}** = NORM_{x,y,z} * frequency_response (see Frequency Response Chart). This linearization is implemented in DASY4 software versions later than 4.2. The uncertainty of the frequency response is included in the stated uncertainty of ConvF.
- DCP_{x,y,z}**: DCP are numerical linearization parameters assessed based on the data of power sweep with CW signal (no uncertainty required). DCP does not depend on frequency nor media.
- PAR**: PAR is the Peak to Average Ratio that is not calibrated but determined based on the signal characteristics
- A_{x,y,z}; B_{x,y,z}; C_{x,y,z}** are numerical linearization parameters in dB assessed based on the data of power sweep for specific modulation signal. The parameters do not depend on frequency nor media.
- VR**: VR is the validity range of the calibration related to the average diode voltage or DAE voltage in mV.
- ConvF and Boundary Effect Parameters**: Assessed in flat phantom using E-field (or Temperature Transfer Standard for $f \leq 800$ MHz) and inside waveguide using analytical field distributions based on power measurements for $f > 800$ MHz. The same setups are used for assessment of the parameters applied for boundary compensation (alpha, depth) of which typical uncertainty values are given. These parameters are used in DASY4 software to improve probe accuracy close to the boundary. The sensitivity in TSL corresponds to NORM_{x,y,z} * ConvF whereby the uncertainty corresponds to that given for ConvF. A frequency dependent ConvF is used in DASY version 4.4 and higher which allows extending the validity from ± 50 MHz to ± 100 MHz.
- Spherical isotropy (3D deviation from isotropy)**: in a field of low gradients realized using a flat phantom exposed by a patch antenna.
- Sensor Offset**: The sensor offset corresponds to the offset of virtual measurement center from the probe tip (on probe axis). No tolerance required.

Probe EX3DV4

SN:3750

Manufactured: March 26, 2010
Calibrated: April 14, 2011

Calibrated for DASY/EASY Systems
(Note: non-compatible with DASY2 system!)

DASY/EASY - Parameters of Probe: EX3DV4 - SN:3750

Basic Calibration Parameters

	Sensor X	Sensor Y	Sensor Z	Unc (k=2)
Norm ($\mu\text{V}/(\text{V}/\text{m})^2$) ^A	0.45	0.51	0.55	$\pm 10.1 \%$
DCP (mV) ^B	96.3	100.0	95.8	

Modulation Calibration Parameters

UID	Communication System Name	PAR		A dB	B dB	C dB	VR mV	Unc ^E (k=2)
10000	CW	0.00	X	0.00	0.00	1.00	107.2	$\pm 3.0 \%$
			Y	0.00	0.00	1.00	120.0	
			Z	0.00	0.00	1.00	115.4	

The reported uncertainty of measurement is stated as the standard uncertainty of measurement multiplied by the coverage factor $k=2$, which for a normal distribution corresponds to a coverage probability of approximately 95%.

^A The uncertainties of NormX,Y,Z do not affect the E^2 -field uncertainty inside TSL (see Pages 5 and 6).

^B Numerical linearization parameter; uncertainty not required.

^E Uncertainty is determined using the max. deviation from linear response applying rectangular distribution and is expressed for the square of the field value.

DASY/EASY - Parameters of Probe: EX3DV4 - SN:3750

Calibration Parameter Determined in Head Tissue Simulating Media

f (MHz) ^c	Relative Permittivity ^f	Conductivity (S/m) ^f	ConvF X	ConvF Y	ConvF Z	Alpha	Depth (mm)	Unct. (k=2)
750	41.9	0.89	8.65	8.65	8.65	0.79	0.69	± 12.0 %
850	41.5	0.92	8.26	8.26	8.26	0.79	0.70	± 12.0 %
1750	40.1	1.37	7.37	7.37	7.37	0.78	0.63	± 12.0 %
1900	40.0	1.40	7.16	7.16	7.16	0.71	0.68	± 12.0 %
2450	39.2	1.80	6.47	6.47	6.47	0.65	0.66	± 12.0 %
3500	37.9	2.91	5.92	5.92	5.92	0.26	1.50	± 13.1 %
5200	36.0	4.66	4.61	4.61	4.61	0.45	1.80	± 13.1 %
5300	35.9	4.76	4.40	4.40	4.40	0.45	1.80	± 13.1 %
5500	35.6	4.96	4.23	4.23	4.23	0.45	1.80	± 13.1 %
5600	35.5	5.07	4.01	4.01	4.01	0.50	1.80	± 13.1 %
5800	35.3	5.27	4.07	4.07	4.07	0.50	1.80	± 13.1 %

^c Frequency validity of ± 100 MHz only applies for DASY v4.4 and higher (see Page 2), else it is restricted to ± 50 MHz. The uncertainty is the RSS of the ConvF uncertainty at calibration frequency and the uncertainty for the indicated frequency band.

^f At frequencies below 3 GHz, the validity of tissue parameters (ϵ and σ) can be relaxed to ± 10% if liquid compensation formula is applied to measured SAR values. At frequencies above 3 GHz, the validity of tissue parameters (ϵ and σ) is restricted to ± 5%. The uncertainty is the RSS of the ConvF uncertainty for indicated target tissue parameters.

DASY/EASY - Parameters of Probe: EX3DV4- SN:3750

Calibration Parameter Determined in Body Tissue Simulating Media

f (MHz) ^c	Relative Permittivity ^f	Conductivity (S/m) ^f	ConvF X	ConvF Y	ConvF Z	Alpha	Depth (mm)	Unct. (k=2)
750	55.5	0.96	8.48	8.48	8.48	0.79	0.72	± 12.0 %
850	55.2	0.99	8.34	8.34	8.34	0.79	0.70	± 12.0 %
1750	53.4	1.49	7.49	7.49	7.49	0.79	0.73	± 12.0 %
1900	53.3	1.52	7.12	7.12	7.12	0.79	0.70	± 12.0 %
2450	52.7	1.95	6.76	6.76	6.76	0.79	0.65	± 12.0 %
3500	51.3	3.31	5.67	5.67	5.67	0.28	1.60	± 13.1 %
5200	49.0	5.30	4.02	4.02	4.02	0.50	1.90	± 13.1 %
5300	48.9	5.42	3.83	3.83	3.83	0.52	1.90	± 13.1 %
5500	48.6	5.65	3.52	3.52	3.52	0.55	1.90	± 13.1 %
5600	48.5	5.77	3.35	3.35	3.35	0.58	1.90	± 13.1 %
5800	48.2	6.00	3.53	3.53	3.53	0.58	1.90	± 13.1 %

^c Frequency validity of ± 100 MHz only applies for DASY v4.4 and higher (see Page 2), else it is restricted to ± 50 MHz. The uncertainty is the RSS of the ConvF uncertainty at calibration frequency and the uncertainty for the indicated frequency band.

^f At frequencies below 3 GHz, the validity of tissue parameters (ϵ and σ) can be relaxed to ± 10% if liquid compensation formula is applied to measured SAR values. At frequencies above 3 GHz, the validity of tissue parameters (ϵ and σ) is restricted to ± 5%. The uncertainty is the RSS of the ConvF uncertainty for indicated target tissue parameters.

Frequency Response of E-Field (TEM-Cell:ifi110 EXX, Waveguide: R22)

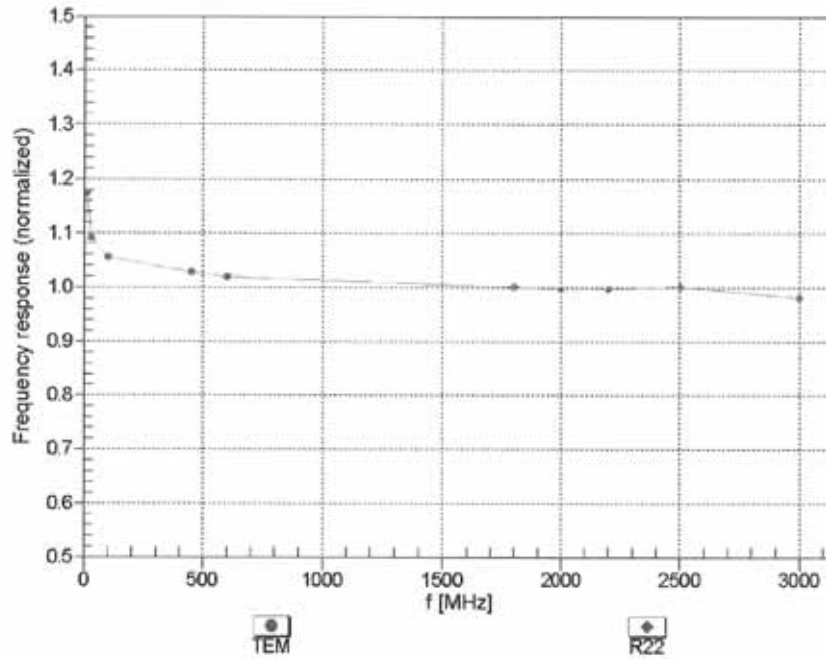

Uncertainty of Frequency Response of E-field: $\pm 6.3\%$ ($k=2$)

Receiving Pattern (ϕ), $\vartheta = 0^\circ$

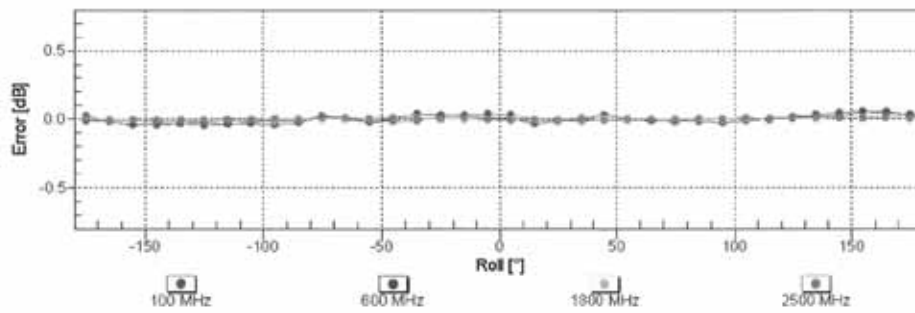
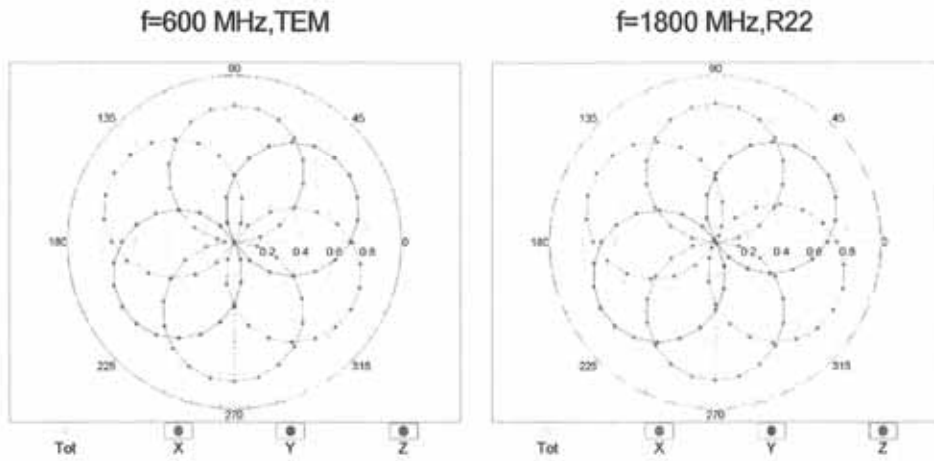

Uncertainty of Axial Isotropy Assessment: $\pm 0.5\%$ (k=2)

Dynamic Range f(SAR_{head}) (TEM cell , f = 900 MHz)

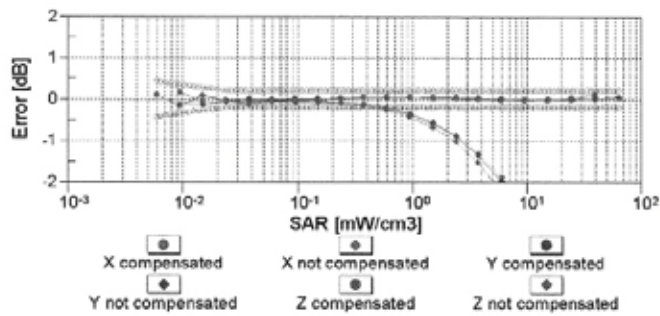
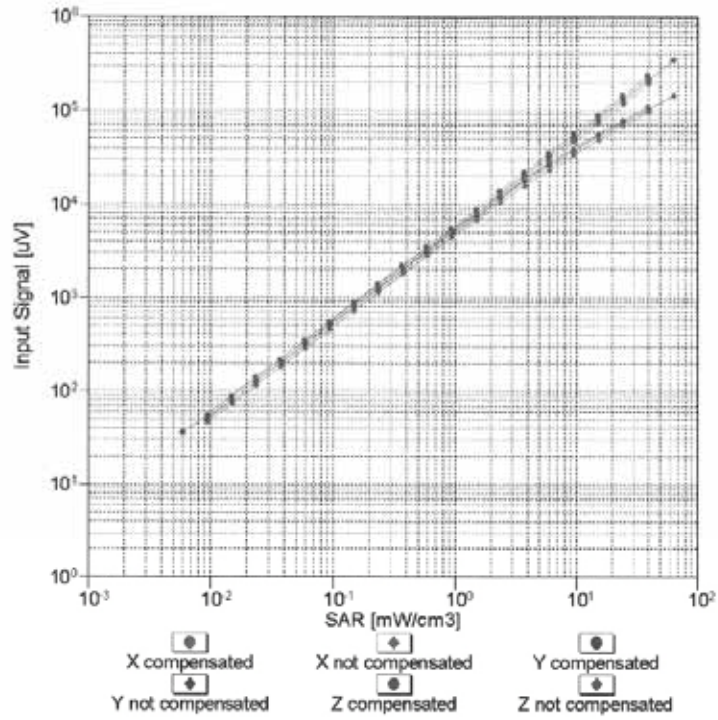

Uncertainty of Linearity Assessment: ± 0.6% (k=2)

Conversion Factor Assessment

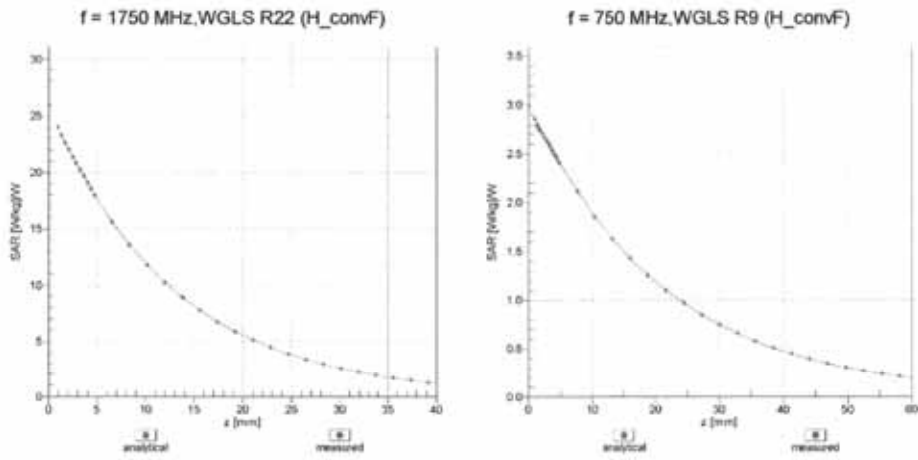

Deviation from Isotropy in Liquid Error (ϕ, θ), f = 900 MHz

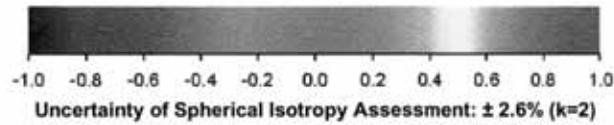
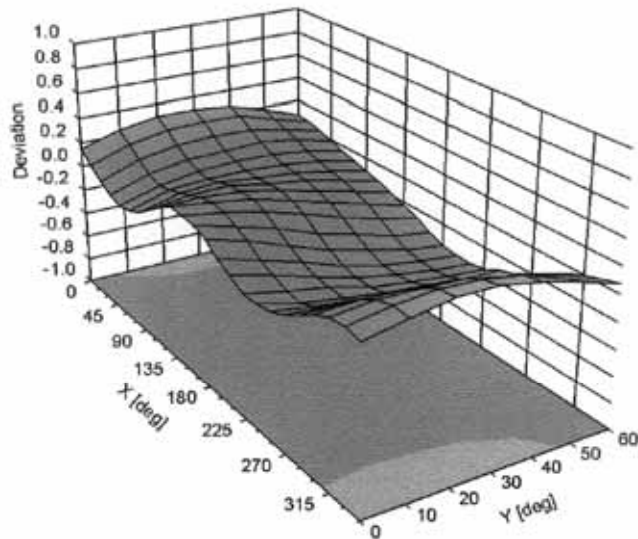

Uncertainty of Spherical Isotropy Assessment: $\pm 2.6\%$ (k=2)

DASY/EASY - Parameters of Probe: EX3DV4 - SN:3750**Other Probe Parameters**

Sensor Arrangement	Triangular
Connector Angle (°)	Not applicable
Mechanical Surface Detection Mode	enabled
Optical Surface Detection Mode	disabled
Probe Overall Length	337 mm
Probe Body Diameter	10 mm
Tip Length	9 mm
Tip Diameter	2.5 mm
Probe Tip to Sensor X Calibration Point	1 mm
Probe Tip to Sensor Y Calibration Point	1 mm
Probe Tip to Sensor Z Calibration Point	1 mm
Recommended Measurement Distance from Surface	2 mm

Calibration Laboratory of
Schmid & Partner
Engineering AG
Zeughausstrasse 43, 8004 Zurich, Switzerland



S Schweizerischer Kalibrierdienst
S Service suisse d'étalonnage
S Servizio svizzero di taratura
S Swiss Calibration Service

Accredited by the Swiss Accreditation Service (SAS)
The Swiss Accreditation Service is one of the signatories to the EA
Multilateral Agreement for the recognition of calibration certificates

Accreditation No.: SCS 108

Client **Samsung (Dymstec)**

Certificate No: ES3-3017_May11

CALIBRATION CERTIFICATE

Object **ES3DV2 - SN:3017**

Calibration procedure(s) **QA CAL-01.v7, QA CAL-23.v4, QA CAL-25.v3
Calibration procedure for dosimetric E-field probes**

Calibration date: **May 20, 2011**

This calibration certificate documents the traceability to national standards, which realize the physical units of measurements (SI).
The measurements and the uncertainties with confidence probability are given on the following pages and are part of the certificate.

All calibrations have been conducted in the closed laboratory facility: environment temperature (22 ± 3)°C and humidity < 70%.

Calibration Equipment used (M&TE critical for calibration)

Primary Standards	ID	Cal Date (Certificate No.)	Scheduled Calibration
Power meter E4419B	GB41293874	31-Mar-11 (No. 217-01372)	Apr-12
Power sensor E4412A	MY41498087	31-Mar-11 (No. 217-01372)	Apr-12
Reference 3 dB Attenuator	SN: S5054 (3c)	29-Mar-11 (No. 217-01369)	Apr-12
Reference 20 dB Attenuator	SN: S5086 (20b)	29-Mar-11 (No. 217-01367)	Apr-12
Reference 30 dB Attenuator	SN: S5129 (30b)	29-Mar-11 (No. 217-01370)	Apr-12
Reference Probe ES3DV2	SN: 3013	29-Dec-10 (No. ES3-3013_Dec10)	Dec-11
DAE4	SN: 654	3-May-11 (No. DAE4-654_May11)	May-12
Secondary Standards	ID	Check Date (in house)	Scheduled Check
RF generator HP 8648C	US3642U01700	4-Aug-99 (in house check Oct-09)	In house check: Oct-11
Network Analyzer HP 8753E	US37390585	18-Oct-01 (in house check Oct-10)	In house check: Oct-11

	Name	Function	Signature
Calibrated by:	Jeton Kastrati	Laboratory Technician	
Approved by:	Katja Pokovic	Technical Manager	

Issued: May 23, 2011

This calibration certificate shall not be reproduced except in full without written approval of the laboratory.

O.k. to use

2011.6.9



Accredited by the Swiss Accreditation Service (SAS)

Accreditation No.: **SCS 108**

The Swiss Accreditation Service is one of the signatories to the EA
Multilateral Agreement for the recognition of calibration certificates

Glossary:

TSL	tissue simulating liquid
NORM _{x,y,z}	sensitivity in free space
ConvF	sensitivity in TSL / NORM _{x,y,z}
DCP	diode compression point
CF	crest factor (1/duty_cycle) of the RF signal
A, B, C	modulation dependent linearization parameters
Polarization φ	φ rotation around probe axis
Polarization ϑ	ϑ rotation around an axis that is in the plane normal to probe axis (at measurement center), i.e., $\vartheta = 0$ is normal to probe axis

Calibration is Performed According to the Following Standards:

- IEEE Std 1528-2003, "IEEE Recommended Practice for Determining the Peak Spatial-Averaged Specific Absorption Rate (SAR) in the Human Head from Wireless Communications Devices: Measurement Techniques", December 2003
- IEC 62209-1, "Procedure to measure the Specific Absorption Rate (SAR) for hand-held devices used in close proximity to the ear (frequency range of 300 MHz to 3 GHz)", February 2005

Methods Applied and Interpretation of Parameters:

- NORM_{x,y,z}**: Assessed for E-field polarization $\vartheta = 0$ ($f \leq 900$ MHz in TEM-cell; $f > 1800$ MHz: R22 waveguide). NORM_{x,y,z} are only intermediate values, i.e., the uncertainties of NORM_{x,y,z} does not affect the E²-field uncertainty inside TSL (see below ConvF).
- NORM(f)_{x,y,z}** = NORM_{x,y,z} * frequency_response (see Frequency Response Chart). This linearization is implemented in DASY4 software versions later than 4.2. The uncertainty of the frequency response is included in the stated uncertainty of ConvF.
- DCP_{x,y,z}**: DCP are numerical linearization parameters assessed based on the data of power sweep with CW signal (no uncertainty required). DCP does not depend on frequency nor media.
- PAR**: PAR is the Peak to Average Ratio that is not calibrated but determined based on the signal characteristics
- A_{x,y,z}; B_{x,y,z}; C_{x,y,z}** are numerical linearization parameters in dB assessed based on the data of power sweep for specific modulation signal. The parameters do not depend on frequency nor media.
- VR**: VR is the validity range of the calibration related to the average diode voltage or DAE voltage in mV.
- ConvF and Boundary Effect Parameters**: Assessed in flat phantom using E-field (or Temperature Transfer Standard for $f \leq 800$ MHz) and inside waveguide using analytical field distributions based on power measurements for $f > 800$ MHz. The same setups are used for assessment of the parameters applied for boundary compensation (alpha, depth) of which typical uncertainty values are given. These parameters are used in DASY4 software to improve probe accuracy close to the boundary. The sensitivity in TSL corresponds to NORM_{x,y,z} * ConvF whereby the uncertainty corresponds to that given for ConvF. A frequency dependent ConvF is used in DASY version 4.4 and higher which allows extending the validity from ± 50 MHz to ± 100 MHz.
- Spherical isotropy (3D deviation from isotropy)**: in a field of low gradients realized using a flat phantom exposed by a patch antenna.
- Sensor Offset**: The sensor offset corresponds to the offset of virtual measurement center from the probe tip (on probe axis). No tolerance required.

Probe ES3DV2

SN:3017

Manufactured: December 5, 2002
Calibrated: May 20, 2011

Calibrated for DASY/EASY Systems
(Note: non-compatible with DASY2 system!)

DASY/EASY - Parameters of Probe: ES3DV2 - SN:3017

Basic Calibration Parameters

	Sensor X	Sensor Y	Sensor Z	Unc (k=2)
Norm ($\mu\text{V}/(\text{V/m})^2$) ^A	1.65	1.68	1.71	$\pm 10.1\%$
DCP (mV) ^B	99.7	98.4	99.8	

Modulation Calibration Parameters

UID	Communication System Name	PAR		A dB	B dB	C dB	VR mV	Unc ^E (k=2)
10000	CW	0.00	X	0.00	0.00	1.00	132.3	$\pm 3.0\%$
			Y	0.00	0.00	1.00	128.9	
			Z	0.00	0.00	1.00	137.6	

The reported uncertainty of measurement is stated as the standard uncertainty of measurement multiplied by the coverage factor $k=2$, which for a normal distribution corresponds to a coverage probability of approximately 95%.

^A The uncertainties of NormX, Y, Z do not affect the E^2 -field uncertainty inside TSL (see Pages 5 and 6).

^B Numerical linearization parameter: uncertainty not required.

^E Uncertainty is determined using the max. deviation from linear response applying rectangular distribution and is expressed for the square of the field value.

DASY/EASY - Parameters of Probe: ES3DV2 - SN:3017

Calibration Parameter Determined in Head Tissue Simulating Media

f (MHz) ^c	Relative Permittivity ^f	Conductivity (S/m) ^f	ConvF X	ConvF Y	ConvF Z	Alpha	Depth (mm)	Unct. (k=2)
750	41.9	0.89	6.55	6.55	6.55	0.46	1.43	± 12.0 %
850	41.5	0.92	6.31	6.31	6.31	0.56	1.21	± 12.0 %
1750	40.1	1.37	5.30	5.30	5.30	0.46	1.40	± 12.0 %
1900	40.0	1.40	5.03	5.03	5.03	0.43	1.49	± 12.0 %
2000	40.0	1.40	5.01	5.01	5.01	0.44	1.39	± 12.0 %
2300	39.5	1.67	4.60	4.60	4.60	0.40	1.49	± 12.0 %
2450	39.2	1.80	4.28	4.28	4.28	0.41	1.47	± 12.0 %
2600	39.0	1.96	4.12	4.12	4.12	0.42	1.50	± 12.0 %

^c Frequency validity of ± 100 MHz only applies for DASY v4.4 and higher (see Page 2), else it is restricted to ± 50 MHz. The uncertainty is the RSS of the ConvF uncertainty at calibration frequency and the uncertainty for the indicated frequency band.

^f At frequencies below 3 GHz, the validity of tissue parameters (ϵ and σ) can be relaxed to ± 10% if liquid compensation formula is applied to measured SAR values. At frequencies above 3 GHz, the validity of tissue parameters (ϵ and σ) is restricted to ± 5%. The uncertainty is the RSS of the ConvF uncertainty for indicated target tissue parameters.

DASY/EASY - Parameters of Probe: ES3DV2- SN:3017

Calibration Parameter Determined in Body Tissue Simulating Media

f (MHz) ^C	Relative Permittivity ^F	Conductivity (S/m) ^F	ConvF X	ConvF Y	ConvF Z	Alpha	Depth (mm)	Unct. (k=2)
750	55.5	0.96	6.34	6.34	6.34	0.61	1.26	± 12.0 %
850	55.2	0.99	6.21	6.21	6.21	0.69	1.17	± 12.0 %
1750	53.4	1.49	4.90	4.90	4.90	0.46	1.58	± 12.0 %
1900	53.3	1.52	4.53	4.53	4.53	0.41	1.62	± 12.0 %
2000	53.3	1.52	4.48	4.48	4.48	0.36	1.80	± 12.0 %
2300	52.9	1.81	4.06	4.06	4.06	0.38	1.54	± 12.0 %
2450	52.7	1.95	3.83	3.83	3.83	0.52	1.09	± 12.0 %
2600	52.5	2.16	3.67	3.67	3.67	0.41	1.30	± 12.0 %

^C Frequency validity of ± 100 MHz only applies for DASY v4.4 and higher (see Page 2), else it is restricted to ± 50 MHz. The uncertainty is the RSS of the ConvF uncertainty at calibration frequency and the uncertainty for the indicated frequency band.

^F At frequencies below 3 GHz, the validity of tissue parameters (ϵ and σ) can be relaxed to ± 10% if liquid compensation formula is applied to measured SAR values. At frequencies above 3 GHz, the validity of tissue parameters (ϵ and σ) is restricted to ± 5%. The uncertainty is the RSS of the ConvF uncertainty for indicated target tissue parameters.

Frequency Response of E-Field (TEM-Cell:ifi110 EXX, Waveguide: R22)

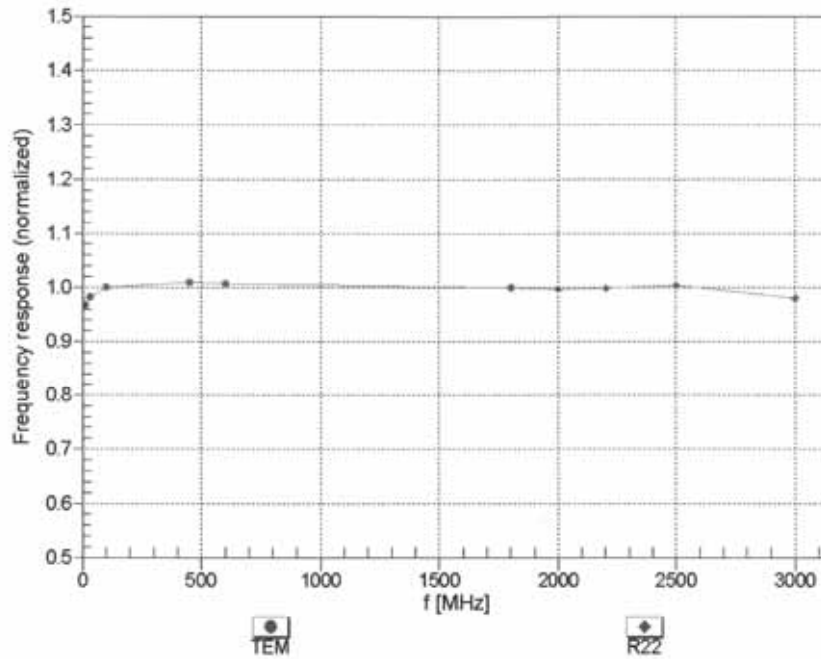

Uncertainty of Frequency Response of E-field: $\pm 6.3\%$ (k=2)

Receiving Pattern (ϕ), $\vartheta = 0^\circ$

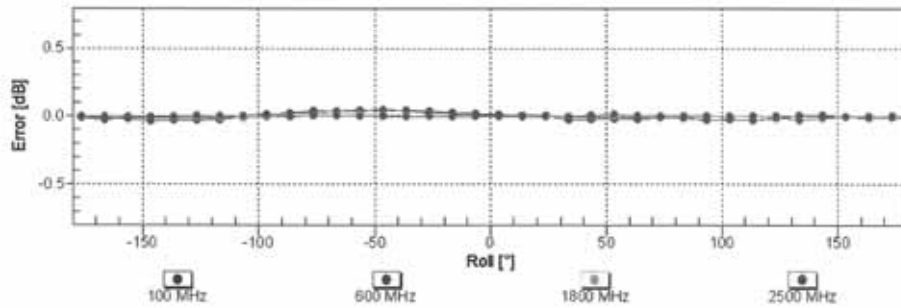
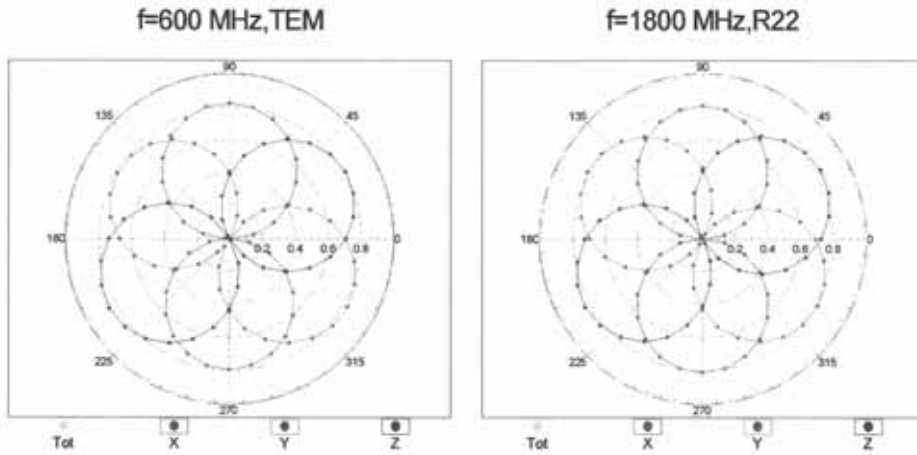

Uncertainty of Axial Isotropy Assessment: $\pm 0.5\%$ ($k=2$)

Dynamic Range f(SAR_{head}) (TEM cell , f = 900 MHz)

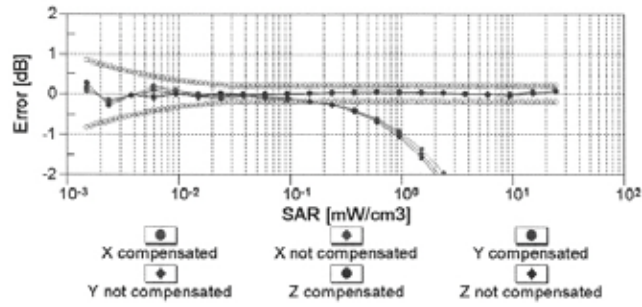
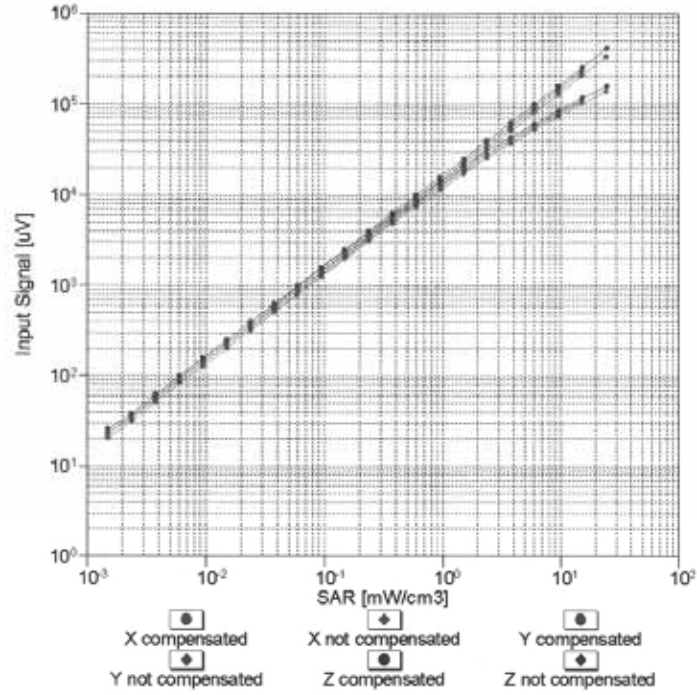

Uncertainty of Linearity Assessment: ± 0.6% (k=2)

Conversion Factor Assessment

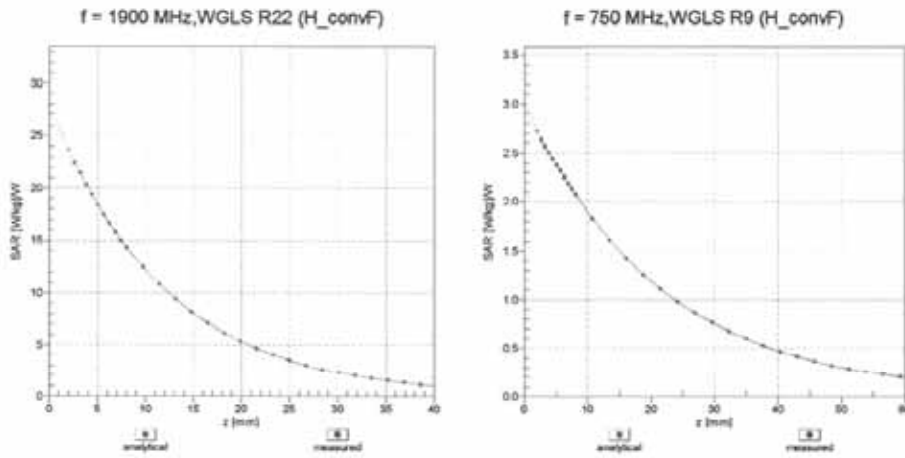

Deviation from Isotropy in Liquid Error (ϕ, θ), f = 900 MHz

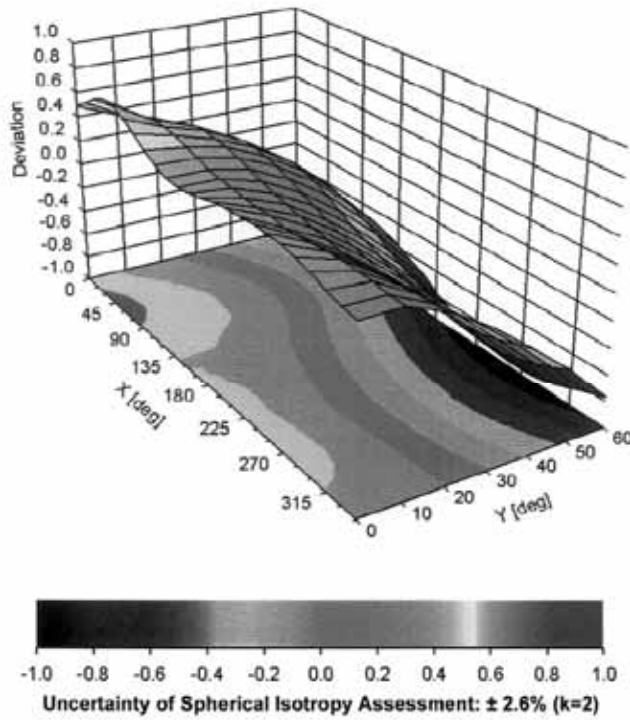

DASY/EASY - Parameters of Probe: ES3DV2 - SN:3017**Other Probe Parameters**

Sensor Arrangement	Triangular
Connector Angle (°)	Not applicable
Mechanical Surface Detection Mode	enabled
Optical Surface Detection Mode	disabled
Probe Overall Length	337 mm
Probe Body Diameter	10 mm
Tip Length	10 mm
Tip Diameter	4 mm
Probe Tip to Sensor X Calibration Point	2 mm
Probe Tip to Sensor Y Calibration Point	2 mm
Probe Tip to Sensor Z Calibration Point	2 mm
Recommended Measurement Distance from Surface	3 mm