



SAMSUNG ELECTRONICS Co., Ltd.,
Regulatory Compliance Group
IT R&D Center
416 Maetan3-Dong,
Yeongtong-gu, Suwon city,
Gyeonggi-Do, Korea 443-742

FCC CFR47 PART 22 & 24 SUBPART CERTIFICATION REPORT

Model Tested : GT-S3572
Additional Model : GT-S3570
FCC ID (Requested) : A3LGTS3572
Report No : FJ-160-R1
Job No : FJ-160
Date issued : July 4, 2012

- Abstract -

All measurement reported herein accordance with FCC Rules, 47CFR Part2,
Part22, Part24.

Prepared By

HK LEE – Test Engineer

Authorized By

WT JANG – Technical Manager



TABLE OF CONTENT

MEASUREMENT REPORT	Page
1. FCC CERTIFICATION INFORMATION	3
1.1. §2.1033 General Information	3
2. INTRODUCTION	4
2.1. General	4
3. MEASURING INSTRUMENT CALIBRATION	5
4. TEST EQUIPMENT LIST	6
5. DESCRIPTION OF TESTS	7
5.1. Effective Radiated Power / Equivalent Isotropic Radiated Power	7
5.2. Radiated Spurious & Harmonic Emission	8
5.3. Peak-Average Ratio	9
5.4. Occupied Bandwidth	10
5.5. Spurious and Harmonic Emission at Antenna Terminal	10
5.5.1. Occupied Bandwidth Emission Limits	10
5.5.2. Conducted Spurious Emission	12
5.6. Frequency Stability / Temperature Variation	13
6. TEST DATA	14
6.1. Effective Radiated Power (E.R.P.)	14
6.2. Equivalent Isotropic Radiated Power (E.I.R.P.)	15
6.3. GSM850 Radiated Spurious & Harmonic measurement	16
6.4. GSM1900 Radiated Spurious & Harmonic measurement	17
6.5. Frequency Stability	18
6.5.1. GSM850 Frequency Stability Table	18
6.5.2. GSM850 Frequency Stability Graph	19
6.5.3. GSM1900 Frequency Stability Table	21
6.5.4. GSM1900 Frequency Stability Graph	22
7. CONCLUSION	24
8. TEST PLOTS	25



MEASUREMENT REPORT

1. FCC Certification Information

The following information is in accordance with FCC Rules, 47CFR Part2, Subpart J, Sections 2.1033 – 2.1055.

1.1. §2.1033 General Information

- Applicant Name : SAMSUNG ELECTRONICS CO., LTD.
- Address : 416 Maetan3-Dong, Yeongtong-gu, Suwon City
Gyeonggi-Do, Korea 443-742
- FCC ID : A3LGTS3572
- Model : GT-S3572
- Additional Model : GT-S3570
- Quantity : Quantity production is planned
- Emission Designators : 250KGXW(GSM850)
253KGXW(GSM1900)
- Tx Freq. Range : 824.2 - 848.8MHz (GSM850)
1850.2MHz - 1909.8MHz (GSM1900)
- Rx Freq. Range : 869.2 - 893.8 MHz (GSM850)
1930.2MHz - 1989.8MHz (GSM1900)
- Max. Power Rating : 0.476 W ERP GSM850 (26.78 dBm)
1.265 W EIRP GSM1900 (31.02 dBm)
- FCC Classification(s) : PCS Licensed Portable Tx Held to Ear (PCE)
- Equipment (EUT) Type : Portable Handset
- Device Capabilities : 850/1900 GSM/GPRS Phone with Bluetooth, EDGE Rx
only and WLAN
- Frequency Tolerance : $\pm 0.00025\%$ (2.5ppm)
- FCC Rule Part(s) : §24(E), §22(H), §2.
- Dates of Test : June 1-2, 2012
- Place of Test : SAMSUNG Lab,
- Test Report S/N : FJ-160-R1

2. INTRODUCTION

2.1. General

These measurement test were conducted at **SAMSUNG ELECTRONICS CO., LTD(SUWON)**. The site address is 416 Maetan3-Dong, Yeongtong-gu, Suwon City, Gyeonggi-Do, Korea 443-742 The site have 1 Fully-anechoic chamber and measurement facility.

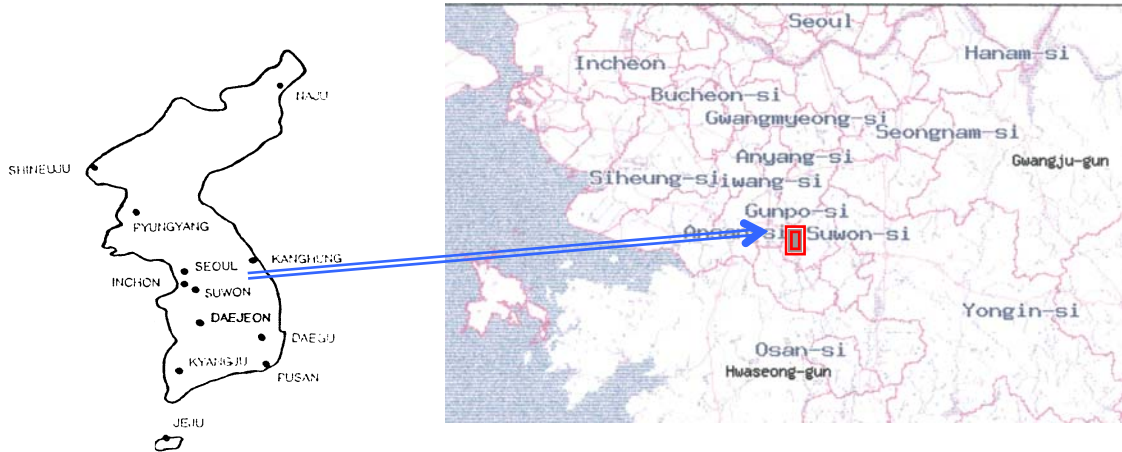

Figure1. Map of the Suwon City area.

Measurement Procedure

The radiated and spurious measurements were made Fully-anechoic chamber at a 3-meter test range (see Figure2). The equipment under testing was placed on the rotating device at the same height and at a distance of 3-meters from the receive antenna. The rotating device which can rotate horizontal axis was mounted on the turn unit to facilitate rotation around a vertical axis. The measurement was made for each horizontal/vertical position combination with receive antenna horizontally polarized. This measurement was repeated with receive antenna vertically polarized. The substitution antenna will replace the EUT antenna it the same position and in vertical polarization. The frequency of the signal generator shall be set to the frequencies that were measured on the EUT. The signal generator, output level, shall be adjusted until an equal or a known related level to what was measured from the EUT is obtained in the spectrum analyzer. This level was recorded. For readings above 1 GHz, the above procedure is repeated using horn antennas and the difference between the gain of the horn and an isotropic antenna are taken into consideration.



Figure2. Photograph of 3m Fully-Anechoic Chamber



3. MEASURING INSTRUMENT CALIBRATION

The measuring equipment, which was utilized in performing the tests documented herein, has been calibrated in accordance with the manufacturer's recommendations for utilizing calibration equipment, which is traceable to recognized national standards.

4. TEST EQUIPMENT LIST

Name Of Equipment	Model	Serial No.	Due Date
Spectrum Analyzer	ESI26	836119/010	2012-10-25
	E4440A(3Hz~26.5GHz)	MY46187454	2013-03-14
	E4440A(3Hz~26.5GHz)	MY41000236	2013-04-26
Signal Generator	SMR20	835197/030	2012-12-01
Network Analyzer	8753E	JP38160590	2013-06-19
Pre-Amplifier	8449B	3008A00691	2012-12-09
Communication test set	8960	MY47510060	2013-03-05
	8960	GB42360886	2012-09-02
Controller	CO2000	CO2000/424	Not Required
Turn Unit	CT0800	CT0800/057	Not Required
Rotating Device	DE3600-RH-PR	DE3600-RH-PR/050	Not Required
Antenna Master	MA4000	MA4000/204	Not Required
Horn Antenna	HF906	100134	2013-09-05
	BBHA9120	9120D-636	2012-07-14
Dipole Antenna	UHA 9105	9105-2412	2013-09-09
	UHA 9105	9105-2413	2012-07-15
Receive Antenna	HL040	353255/019	2013-09-05
Power Supply	E3640A	MY40003594	2013-06-19
	E3640A	MY40003595	2013-05-16
	E3632A	MY40022438	2013-03-02
Divider	11636B	51946	2012-07-04
	11636B	51942	2012-07-05
	11636B	56918	2012-09-28
High Pass Filter	WHK/3.0/18G-10SS	492	2013-04-09
	WHK/3.5/18G-10SS	4	2013-04-09
Environmental Chamber	SH-241	92000548	2012-11-14
	SH-241	92000549	2012-11-14
Shielded Fully Anechoic Chamber	CHAMBER	ANT0001	Not Required

5. DESCRIPTION OF TESTS

5.1. Effective Radiated Power / Equivalent Isotropic Radiated Power

Test Set-up for the ERP/EIRP TEST

Effective Radiated Power Output and Equivalent Isotropic Radiated Power output Measurements by Substitution Method according to ANSI/TIA/EIA-603-C-2004

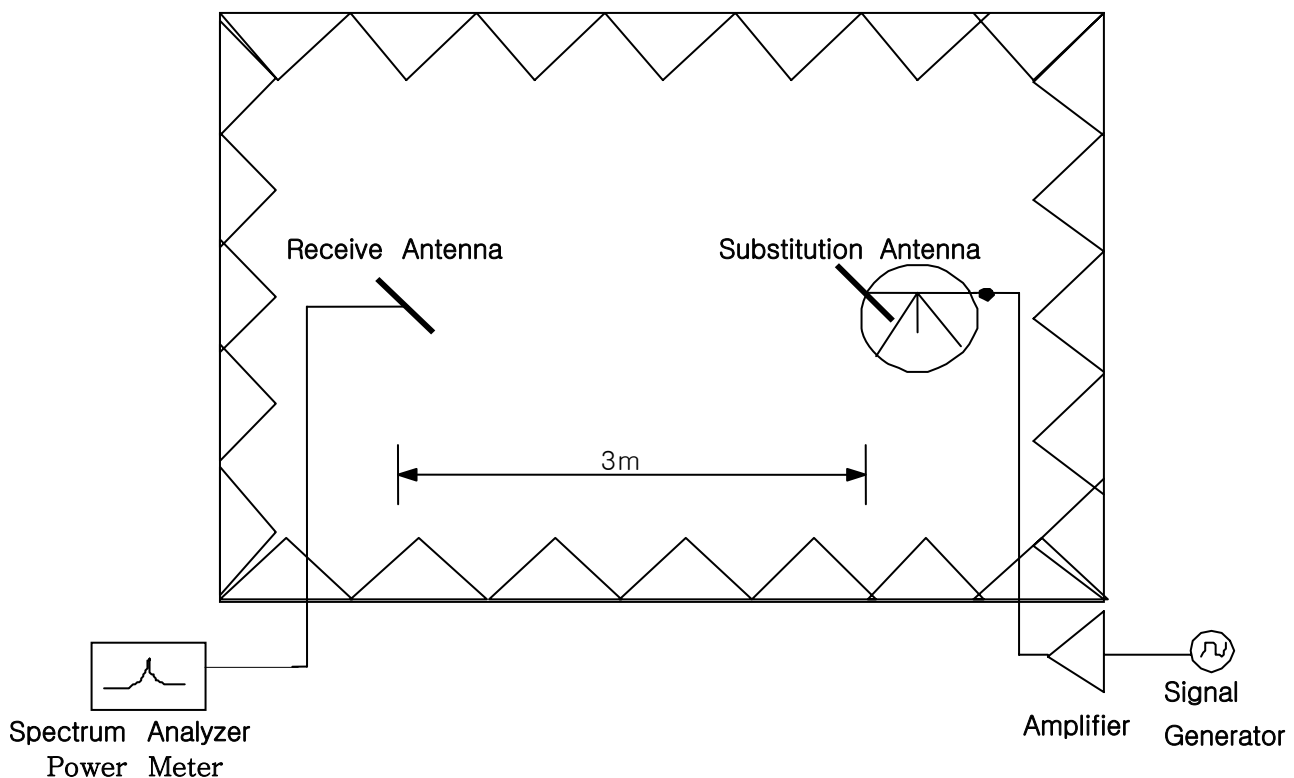

Figure 3. Diagram of ERP/EIRP test Set-up

The EUT was placed on the rotating device at 3-meters from the receive antenna and tested in 3 orthogonal planes. The turn unit and rotating device was adjusted for the highest reading on the receive spectrum analyzer. For GSM signals, an average detector is used, with RBW=VBW=3MHz, SPAN=10MHz. A half-wave dipole and Horn antenna was substituted in place of the EUT. This dipole antenna was driven by a signal generator and the level of the signal generator was adjusted to obtain the same receive spectrum analyzer reading. The conducted power at the terminals of dipole is measured. The ERP and EIRP are recorded. For readings above 1GHz, the above procedure is repeated using horn antennas and the difference between the gain of the horn and an isotropic or dipole antenna are taken into consideration.

5.2. Radiated Spurious & Harmonic Emission

Test Set-up for the Radiated Emission TEST

Radiated Spurious Emission Measurements by Substitution Method according to ANSI/TIA/EIA-603-C-2004

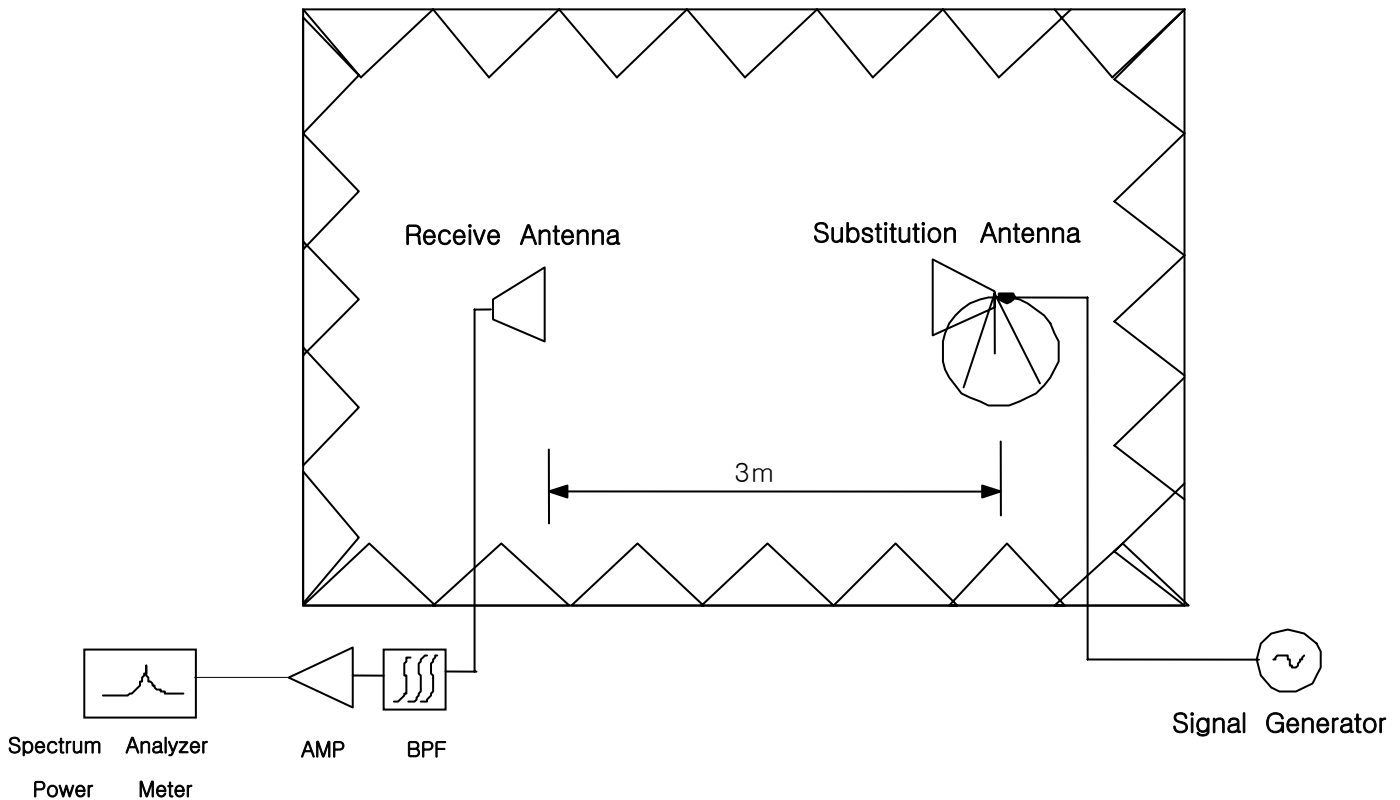

Figure 4. Diagram of Radiated Spurious & Harmonic test Set-up

The EUT was placed on the rotating device at 3-meters from the receive antenna and tested in 3 orthogonal planes. The turn unit and rotating device was adjusted for the highest reading on the receive spectrum analyzer. The Spectrum was investigated from 30MHz to the 10th Harmonic of the fundamental. A peak detector is used, with RBW=VBW=1MHz. The value that we could measure was only reported. A half-wave dipole was substituted in place of the EUT. This dipole antenna was driven by a signal generator and the level of the signal generator was adjusted to obtain the same receive spectrum analyzer reading. This spurious level is recorded. For readings above 1GHz, the above procedure is repeated using horn antennas and the difference between the gain of the horn and an isotropic or dipole antenna are taken into consideration.

SAMPLE CALCULATION

Example: Channel 661 , Second Harmonic(3760.00MHz)

The receive analyzer reading at 3meters with the EUT on the turntable was -81.0dBm . The gain of the substituted antenna is 8.1dBi . The signal generator connected to the substituted antenna terminals is adjusted to produce a reading of -81.0dBm of the receive analyzer. The loss of the cable between the signal generator and the terminals of the substituted antenna is 2.0dB at 3760.00MHz . So 6.1dB is added to the signal generator reading of -30.9dBm yielding -24.8dBm . The fundamental EIRP was 25.5dBm so this harmonic was $25.5\text{dBm} - (-24.8) = 50.3\text{dBc}$.

5.3. Peak-Average Ratio

A peak to average ratio measurement is performed at the conducted port of the EUT. An average and a peak trace are used on a spectrum analyzer to determine the largest deviation between the average and the peak power of the EUT in a given bandwidth.

Test set-up

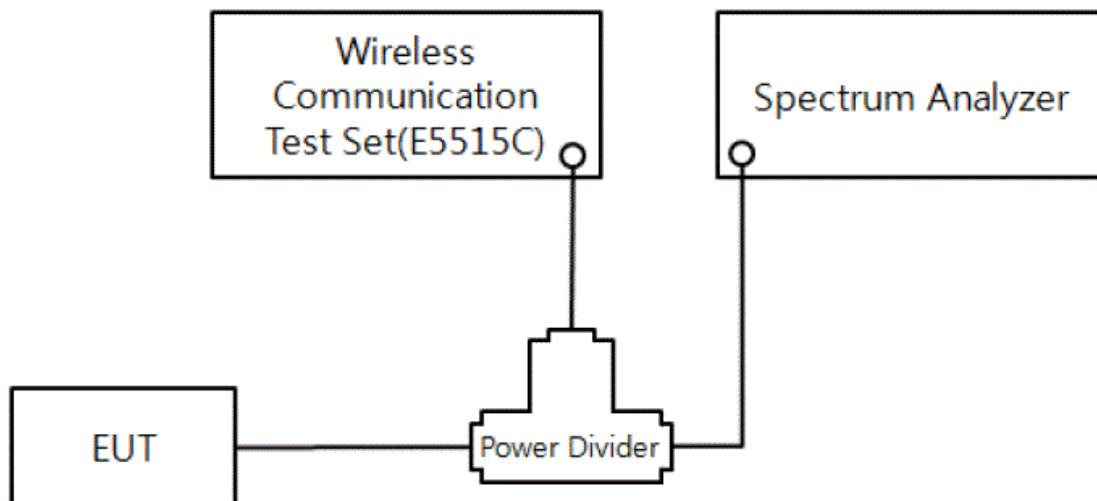

(Configuration of conducted Emission measurement)

5.4.Occupied Bandwidth

Test Procedure

The occupied bandwidth, that is the frequency bandwidth such that, below its lower and above its upper frequency limits, the mean powers radiated are each equal to 0.5 percent of the total mean power radiated by a given emission shall be measured. The span of the analyzer shall be set to capture all products of the modulation process, including the emission skirts. The resolution and video bandwidth shall be set to as close to 1 percent of the selected span as is possible without being below 1 percent. Video averaging is not permitted. The trace data points are recovered and are directly summed in linear terms. The recovered amplitude data points, beginning at the lowest frequency, are placed in a running sum until 0.5 percent of the total is reached and that frequency recorded. The process is repeated for the highest frequency data points. This frequency is recorded, The span between the two recorded frequencies is the occupied bandwidth. These measurements were performed on Agilent E4440A Spectrum Analyzer, and use analyzer's bandwidth measurement function.

5.5. Spurious and Harmonic Emission at Antenna Terminal

5.5.1. Occupied Bandwidth Emission Limits

Part 24

- (a) On any frequency outside a licensee's frequency block, the power of any emission shall be attenuated below the transmitter power (P) by at least $43 + 10 \log(P)$ dB.
- (b) Compliance with these provisions is based on the use of measurement instrumentation employing a resolution bandwidth of 1 MHz or greater. However, in the 1MHz bands immediately outside and adjacent to the frequency block a resolution bandwidth of at least one percent of the emission bandwidth of the fundamental emission of the transmitter may be employed. The emission bandwidth is defined as the width of the signal between two points, one below the carrier center frequency and one above the carrier center frequency, outside of which all emission are attenuated at least 26 dB below the transmitter power.
- (c) When measuring the emission limits, the nominal carrier frequency shall be adjusted as close to the licensee's frequency block edges, both upper and lower, as the design permits.

Part 22

- (a) Out of band emissions. The power of any emission outside of the authorized operating frequency ranges must be attenuated below the transmitting power (P) by a factor of at least $43 + 10 \log(P)$ dB.
- (b) Measurement procedure. Compliance with these rules is based on the use of measurement instrumentation employing a resolution bandwidth of 100 kHz or greater. In the 1 MHz bands immediately outside and adjacent to the frequency block a resolution bandwidth of at least one percent of the emission bandwidth of the fundamental emission of the transmitter may be employed. A narrower resolution bandwidth is permitted in all cases to improve measurement accuracy provided the measured power is integrated over the full required measurement bandwidth (i.e. 100 kHz or 1 percent of emission bandwidth, as specified). The emission bandwidth is defined as the width of the signal between two points, one below the carrier center frequency and one above the carrier center frequency, outside of which all emissions are attenuated at least 26 dB below the transmitter power.

BLOCK	Freq. Range (MHz) Transmitter (Tx)	Freq. Range (MHz) Receiver (Rx)
A	1850 – 1865	1930 – 1945
B	1870 – 1885	1950 – 1965
C	1895 – 1910	1975 – 1990
D	1865 – 1870	1945 – 1950
E	1885 – 1890	1965 – 1970
F	1890 – 1895	1970 – 1975

Table 1. Broadband PCS Service Frequency Blocks

BLOCK	Freq. Range (MHz) Transmitter (Tx)	Freq. Range (MHz) Receiver (Rx)
A* Low + A	824 ~ 835	869 ~ 880
B	835 ~ 845	880 ~ 890
A* High	845 ~ 846.5	890 ~ 891.5
B*	846.5 ~ 849	891.5 ~ 894

Table 2. Cellular Service Frequency Blocks

5.5.2. Conducted Spurious Emission

Minimum standard:

On any frequency outside a license frequency block, the power of any emission shall be attenuated below the transmitter power(P) by at least $43+10\log(P)$ dB. Limit equivalent to -13dBm, calculation shown below.

$$43 + 10\log (0.476 \text{ W}) = 39.78 \text{ dB}$$

$$26.78 \text{ dBm} - 39.78 \text{ dB} = -13 \text{ dBm}$$

Compliance with the out-of-band emissions requirement is based on test being performed with an analyzer resolution bandwidth of 1MHz. However in the 1MHz band immediately outside and adjacent to the frequency block a resolution bandwidth of at least 1% of the fundamental emissions bandwidth may be employed.

Example)

In case of GSM : $0.01 * 273\text{KHz} = 2.73\text{KHz}$

A Resolution BW of 3KHz was used for measurement at the band edges.

Test Procedure:

The EUT was setup to maximum output power at its lowest channel. The Resolution BW of the analyzer is set to 1% of the emission bandwidth to show compliance with the -13dBm limit, in the 1MHz bands immediately outside and adjacent to the edge of the frequency block. The measurements are repeated for the EUT's highest channel. For the Out-of-Band measurements a 1MHz RBW was used to scan from 10MHz to 10GHz. (GSM1900 Mode : 10MHz to 20GHz). A display line was placed at -13dBm to show compliance. The high, lowest and a middle channel were tested for out of band measurements.

Plots are shown herein.

5.6. Frequency Stability / Temperature Variation

The frequency stability of the transmitter is measured by:

- a.) Temperature: The temperature is carried from -30°C to $+50^{\circ}\text{C}$ using an environmental chamber.
- b.) Primary Supply Voltage: The primary supply voltage is varied from 85% to 115% of the voltage normally at the input to the device or at the power supply terminals if cables are not normally supplied.

Specification- The frequency stability shall be sufficient to ensure that the fundamental emission stays within the authorized frequency block. The frequency stability of the transmitter shall be maintained within ± 0.00025 ($\pm 2.5\text{ppm}$) of the center frequency.

Time Period and Procedure:

1. The carrier frequency of the transmitter and the individual oscillators is measured at room temperature (25°C to 27°C to provide a reference).
2. The equipment is subjected to an overnight "soak" at -30°C without any power applied.
3. After the overnight "soak" at -30°C (Usually 14~16 hours), the equipment is turned on in a "standby" condition for one minute before applying power to the transmitter. Measurement of the carrier frequency of the transmitter and the individual oscillators is made within a three minute interval after applying to the transmitter.
4. Frequency measurements are made at 10°C interval up to room temperature. At least a period of one and one half-hour is provided to allow stabilization of the equipment at each temperature level.
5. Again the transmitter carrier frequency and the individual oscillators is measured at room temperature to begin measurement of the upper temperature levels.
6. Frequency measurements are at 10 intervals starting at -30°C up to $+50^{\circ}\text{C}$ allowing at least two hours at each temperature for stabilization. In all measurements the frequency is measured within three minutes after re-applying power to the transmitter.
7. The artificial load is mounted external to the temperature chamber.

NOTE : The EUT is tested down to the battery endpoint.

6. TEST DATA

6.1. Effective Radiated Power (E.R.P.)

Supply Voltage : 3.7VDC

Modulation : GSM850

■ Result

Frequency (MHz)	Tested level [dBm]	Substitute Level [dBm]	Antenna Gain [dBd]	Polarization [H/V]	ERP [dBm]	ERP [W]	Battery
824.20	-9.78	27.72	-1.95	H	25.77	0.378	Standard
836.60	-10.70	27.30	-1.72	H	25.58	0.361	Standard
848.80	-11.82	28.36	-1.58	H	26.78	0.476	Standard

NOTE : Standard batteries are the only battery options for this phone

- All modes of operation were investigated, and the worst-case results are reported.

Radiated measurements at 3 meters by Substitution Method



6.2. Equivalent Isotropic Radiated Power (E.I.R.P.)

Supply Voltage : 3.7VDC

Modulation : PCS 1900

■ Result

Frequency (MHz)	Tested level [dBm]	Substitute Level [dBm]	Antenna Gain [dBi]	Polarization [H/V]	EIRP [dBm]	EIRP [W]	Battery
1850.20	-19.30	19.61	10.16	V	29.77	0.948	Standard
1880.00	-19.08	20.24	10.16	V	30.40	1.096	Standard
1909.80	-18.31	20.86	10.16	V	31.02	1.265	Standard

NOTE : Standard batteries are the only battery options for this phone

- All modes of operation were investigated, and the worst-case results are reported.

Radiated measurements at 3 meters by Substitution Method

6.3. GSM850 Radiated Spurious & Harmonic measurement

Operating Frequency : 824.20 MHz(Low), 836.60MHz(Middle), 848.80MHz(High)

Measured Output Power : 26.78 dBm = 0.476 W

Modulation Signal : GSM850

Limit : $43 + 10\log_{10}(P) = 39.78 \text{ dBc}$

Result

Channel	Harmonic	Frequency (MHz)	Substitute Antenna Gain (dBi)	From EUT Tested level (dBm)	Result (dBc)	POL (H/V)
128	2	1648.40	9.40	-46.37	60.56	H
	3	2472.60	10.60	-54.66	64.35	V
	4	3296.80	12.00	-64.40	69.48	V
	5	4121.00	-	-	-	-
	6	4945.20	-	-	-	-
	7	5769.40	-	-	-	-
190	2	1673.20	9.40	-51.79	65.73	H
	3	2509.80	10.60	-62.29	71.03	H
	4	3346.40	12.00	-66.21	71.38	V
	5	4183.00	-	-	-	-
	6	5019.60	-	-	-	-
	7	5856.20	-	-	-	-
251	2	1697.60	9.40	-57.17	69.83	H
	3	2546.40	10.60	-65.22	74.51	H
	4	3395.20	12.00	-64.43	69.75	H
	5	4244.00	-	-	-	-
	6	5092.80	-	-	-	-
	7	5941.60	-	-	-	-

NOTE :

1. "-" Indicates the spurious emission could not be detected due to noise limitations or ambients.
2. The spectrum is measured from 30MHz to the 10th harmonic and All modes of operation were investigated, and the worst-case results are reported..

Radiated Spurious Emission measurements at 3 meters by Substitution Method

6.4. GSM1900 Radiated Spurious & Harmonic measurement

Operating Frequency : 1850.2 MHz(Low), 1880.00 MHz(Middle), 1909.80 MHz(High)

Measured Output Power : 31.02 dBm = 1.265 W

Modulation Signal : GSM1900

Limit : $43 + 10\log_{10}(P) = 44.02$ dBc

Result

Channel	Harmonic	Frequency (MHz)	Substitute Antenna Gain (dBi)	From EUT Tested level (dBm)	Result (dBc)	POL (H/V)
512	2	3700.40	12.60	-59.40	63.44	H
	3	5550.60	12.50	-64.67	65.29	H
	4	7400.80	11.50	-64.76	60.07	H
	5	9251.00	-	-	-	-
	6	11101.20	-	-	-	-
	7	12951.40	-	-	-	-
661	2	3760.00	12.60	-56.11	60.24	H
	3	5640.00	12.50	-62.60	62.88	H
	4	7520.00	11.50	-65.71	61.67	V
	5	9400.00	-	-	-	-
	6	11280.00	-	-	-	-
	7	13160.00	-	-	-	-
810	2	3819.60	12.60	-56.05	60.12	H
	3	5729.40	12.50	-61.36	61.18	H
	4	7639.20	11.50	-68.34	64.11	H
	5	9549.00	-	-	-	-
	6	11458.80	-	-	-	-
	7	13368.60	-	-	-	-

NOTE :

1. "-" Indicates the spurious emission could not be detected due to noise limitations or ambients.
2. The spectrum is measured from 30MHz to the 10th harmonic and All modes of operation were investigated, and the worst-case results are reported.

Radiated Spurious Emission measurements at 3 meters by Substitution Method

6.5. Frequency Stability

6.5.1. GSM850 Frequency Stability Table

Operating Frequency : 836,600,000 Hz

Channel : 190

Reference Voltage : 3.7VDC

Deviation Limit : ± 0.00025 % or 2.5ppm

Voltage (%)	Power (VDC)	Temp. (°C)	Frequency Error (Hz)	Frequency (Hz)	Deviation (%)	ppm
100%	3.70	+20(Ref)	15.70	836,600,016	0.000002	0.019
100%		-30	28.10	836,600,028	0.000003	0.034
100%		-20	41.20	836,600,041	0.000005	0.049
100%		-10	-9.70	836,599,990	-0.000001	-0.012
100%		0	40.50	836,600,041	0.000005	0.048
100%		+10	18.80	836,600,019	0.000002	0.022
100%		+20	15.70	836,600,016	0.000002	0.019
100%		+30	-41.80	836,599,958	-0.000005	-0.050
100%		+40	-3.60	836,599,996	0.000000	-0.004
100%		+50	-3.90	836,599,996	0.000000	-0.005
115%	4.26	+20	-19.90	836,599,980	-0.000002	-0.024
Batt.Endpoint	3.35	+20	33.40	836,600,033	0.000004	0.040

Note : The temperature is varied from -30 °C to +50 °C using an environmental chamber.

The EUT is tested down to the battery end point.

6.5.2. GSM850 Frequency Stability Graph

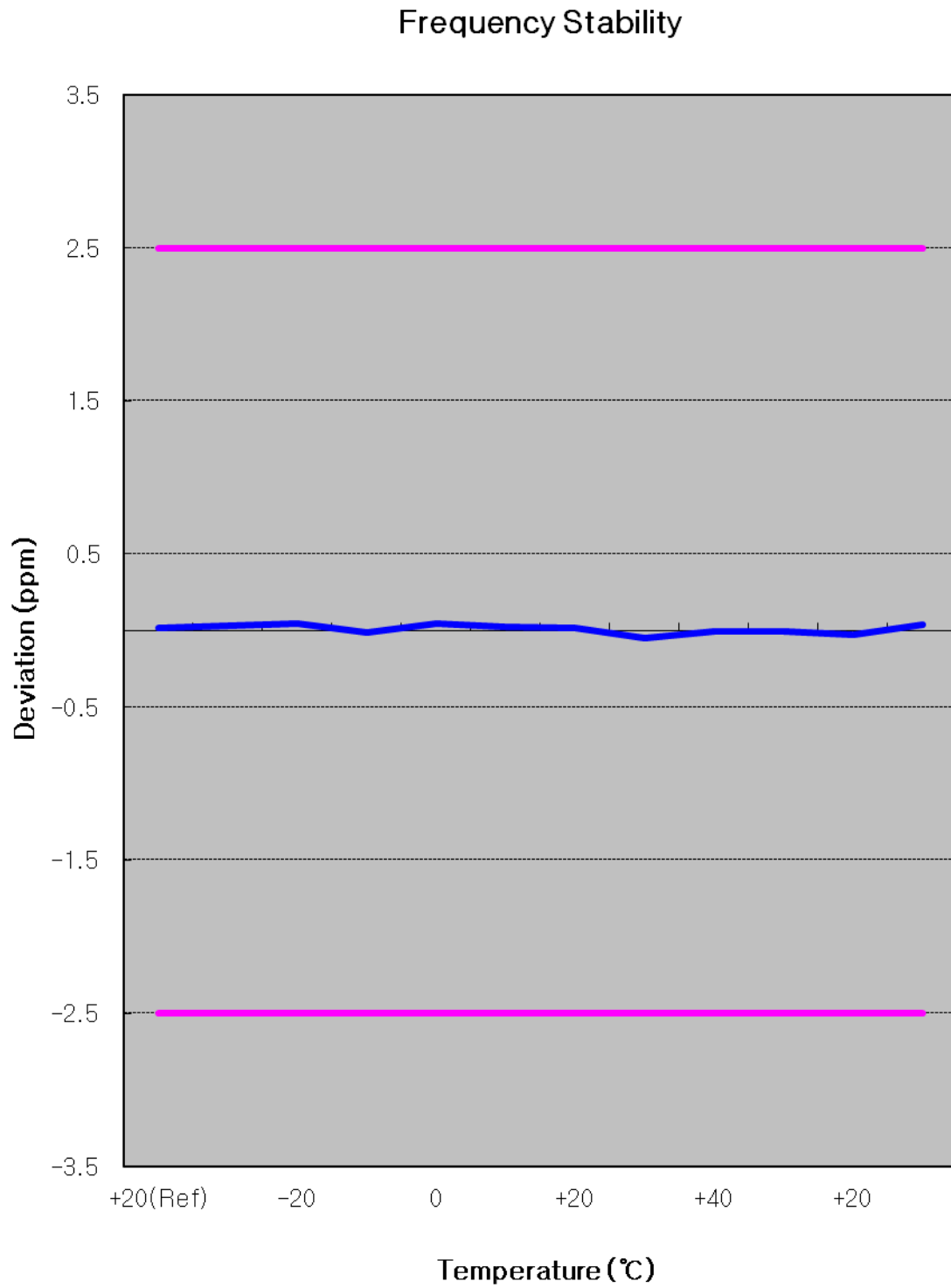

Zoom IN

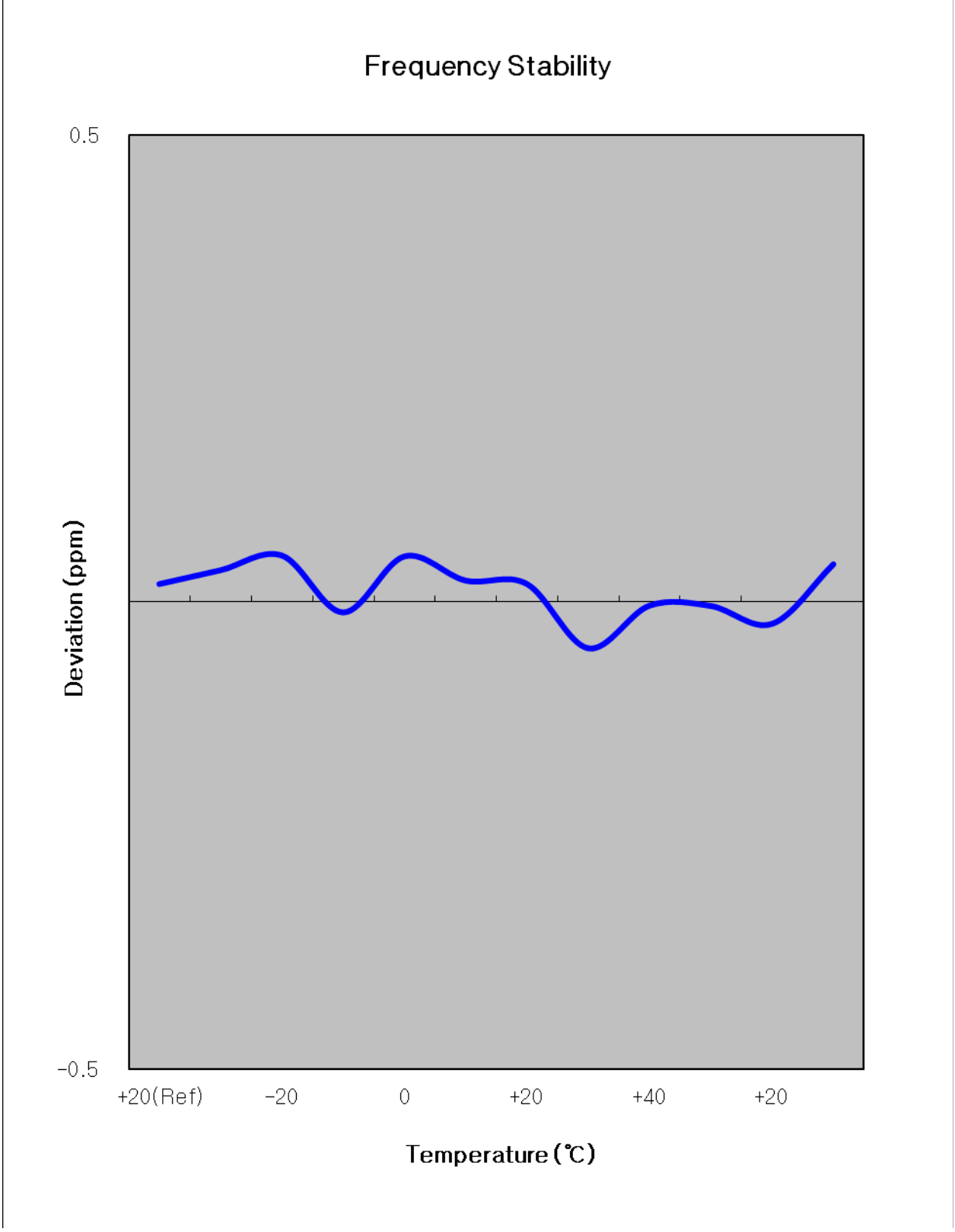

6.5.3. GSM1900 Frequency Stability Table

Operating Frequency : 1,880,000,000 Hz

Channel : 661

Reference Voltage : 3.7VDC

Deviation Limit : ± 0.00025 % or 2.5ppm

Voltage (%)	Power (VDC)	Temp. (°C)	Frequency Error (Hz)	Frequency (Hz)	Deviation (%)	ppm
100%	3.70	+20(Ref)	31.70	1,880,000,032	0.000002	0.017
100%		-30	32.30	1,880,000,032	0.000002	0.017
100%		-20	6.70	1,880,000,007	0.000000	0.004
100%		-10	43.50	1,880,000,044	0.000002	0.023
100%		0	21.70	1,880,000,022	0.000001	0.012
100%		+10	22.20	1,880,000,022	0.000001	0.012
100%		+20	31.70	1,880,000,032	0.000002	0.017
100%		+30	-47.50	1,879,999,953	-0.000003	-0.025
100%		+40	-17.50	1,879,999,983	-0.000001	-0.009
100%		+50	18.20	1,880,000,018	0.000001	0.010
115%		4.26	+20	5.00	1,880,000,005	0.000000
Batt.Endpoint	3.35	+20	38.80	1,880,000,039	0.000002	0.021

Note : The temperature is varied from -30 °C to +50 °C using an environmental chamber.

The EUT is tested down to the battery end point.

6.5.4. GSM1900 Frequency Stability Graph

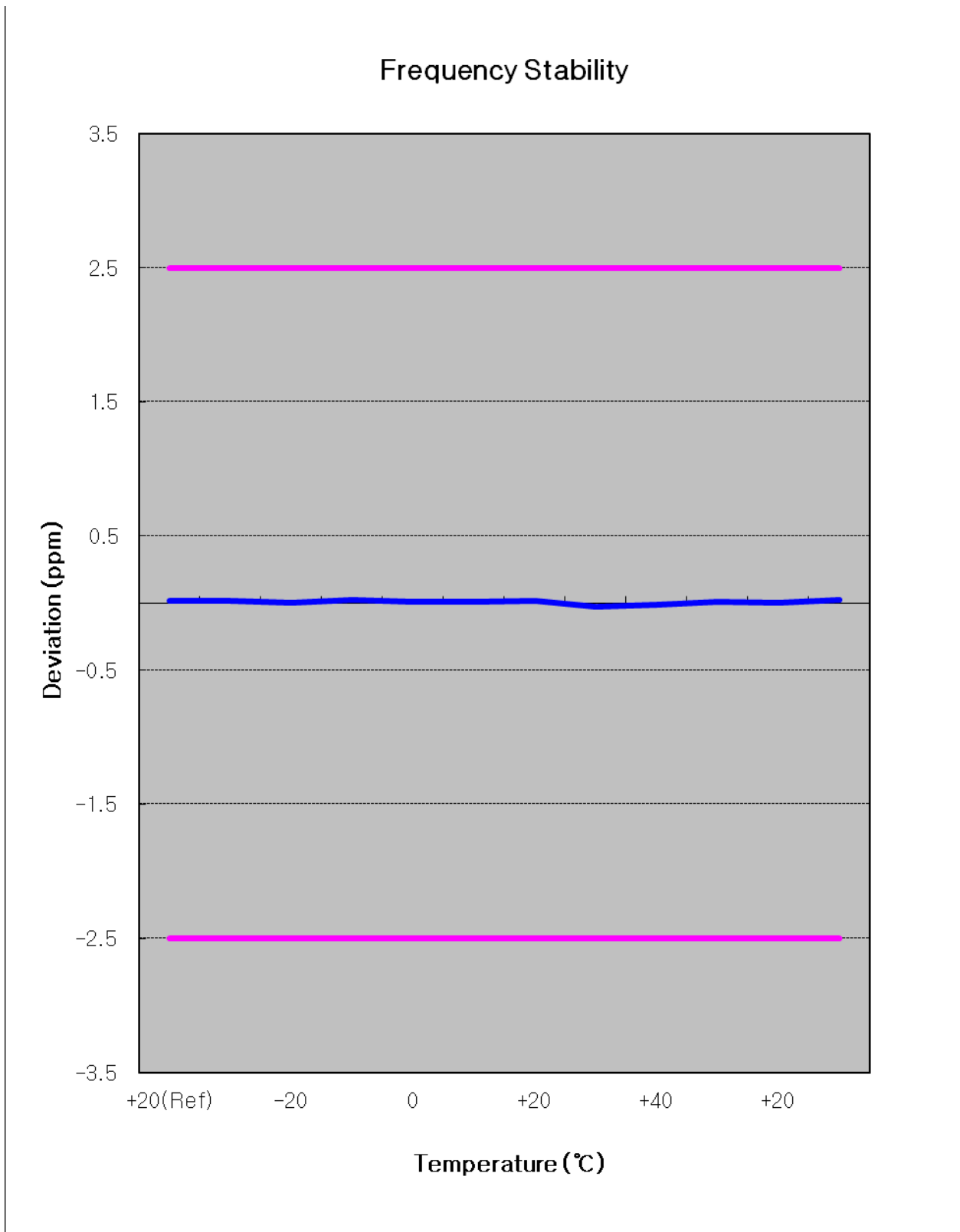

Zoom IN

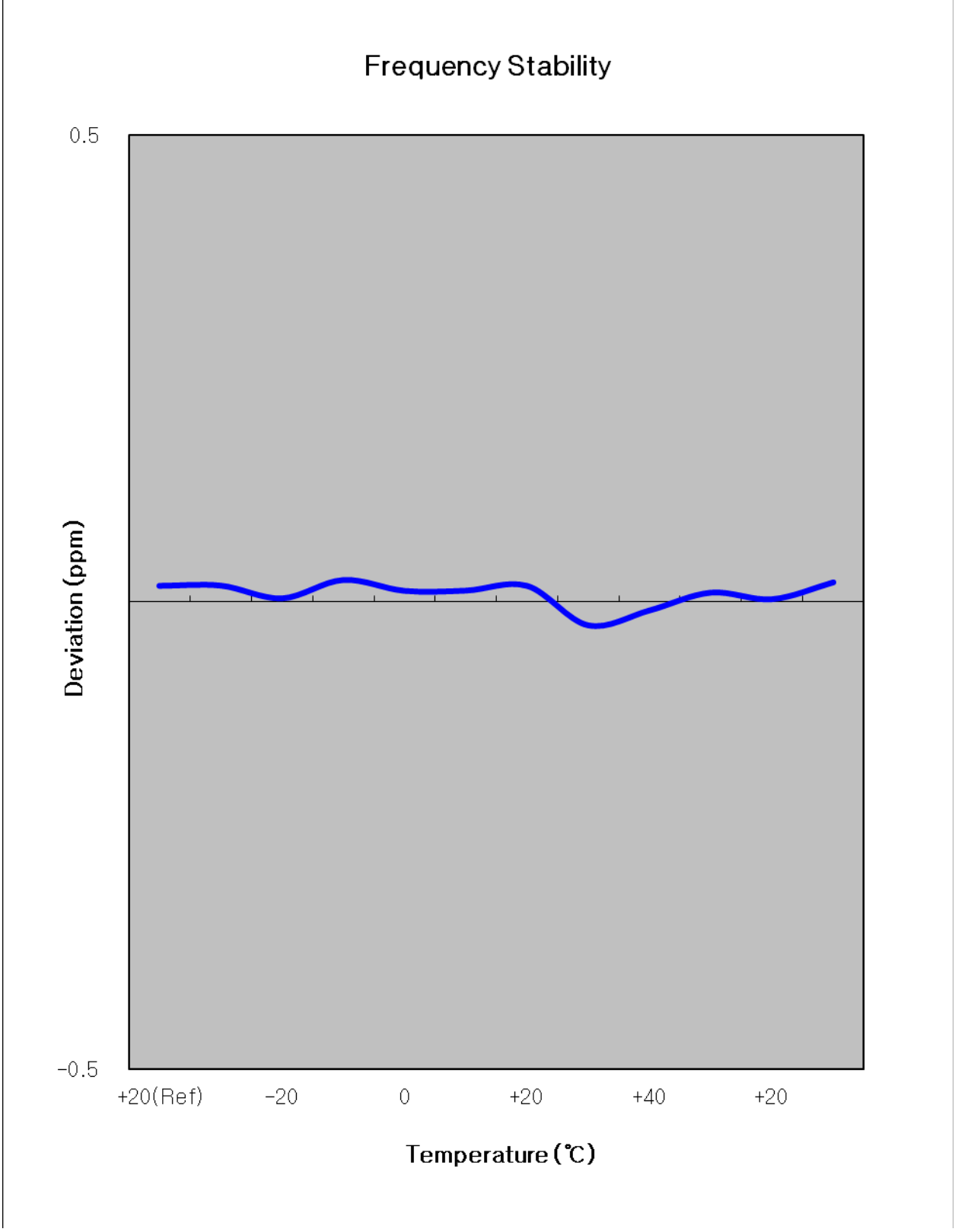



7. CONCLUSION

The data collected shows that the SAMSUNG Portable Handset
FCC ID : A3LGTS3572 complies with all the requirements of Parts 2,22,24 of the FCC Rules.

8. TEST PLOTS

※ For above 5GHz, we measure Ref. offset every 1GHz. And we tested the plots with worst offset of all offset.

1. Spectrum Offset(dB) = Cable loss(dB) + Power divider(dB)
2. Ref Offset at 1880 MHz = 9.56dBm

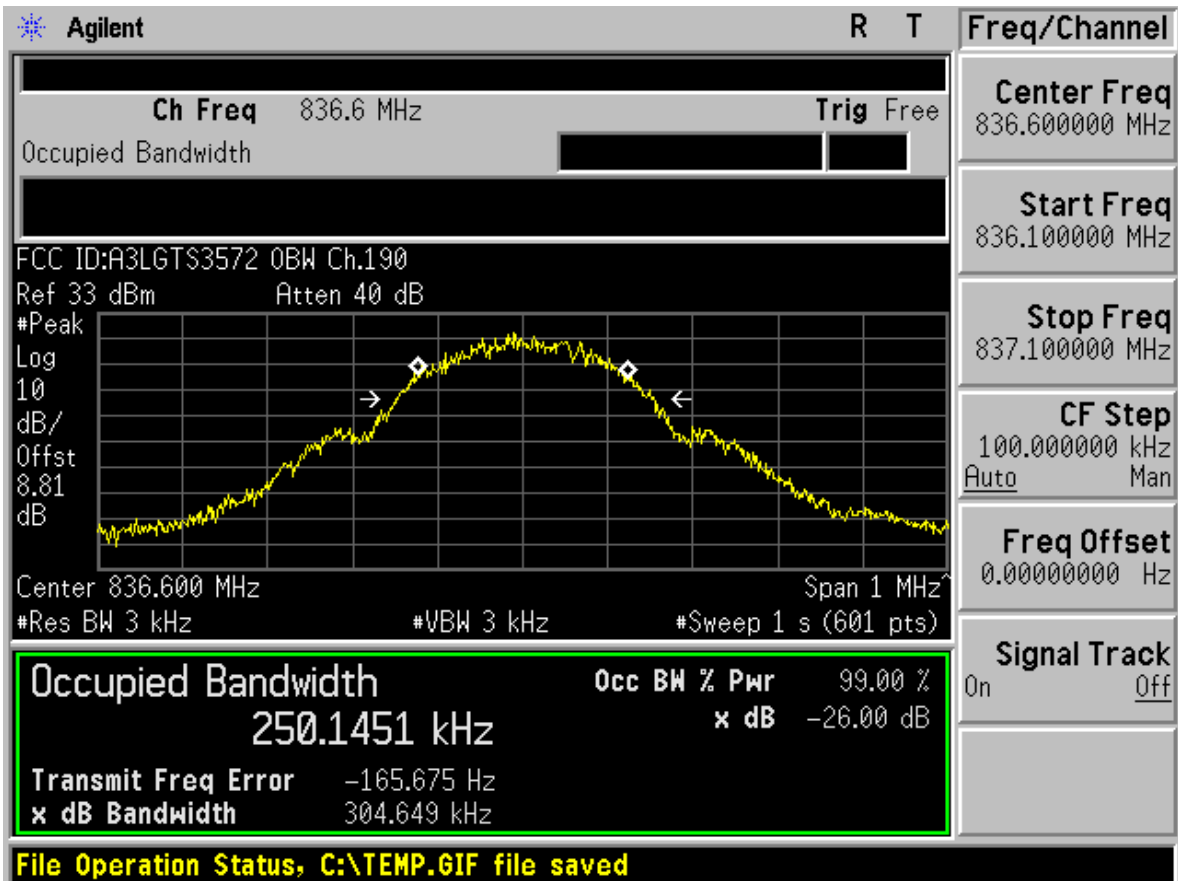
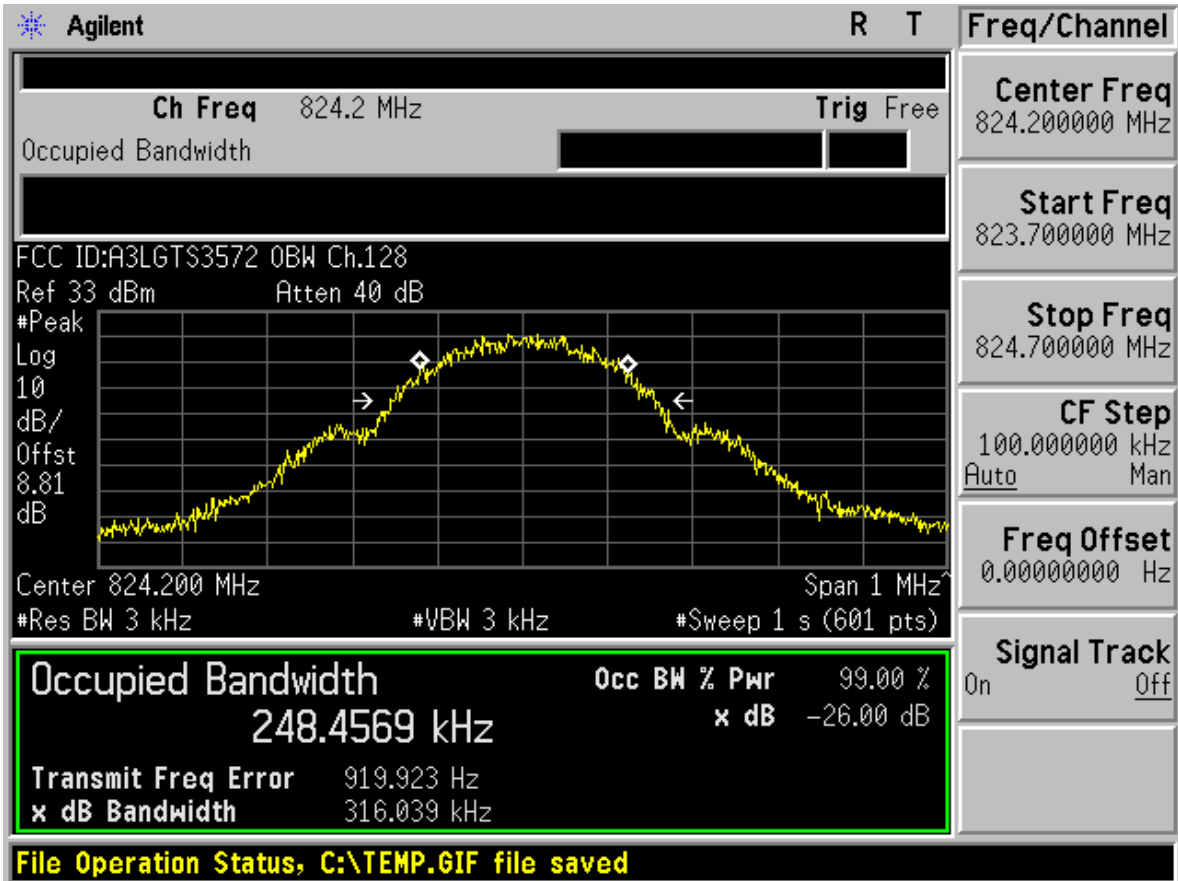

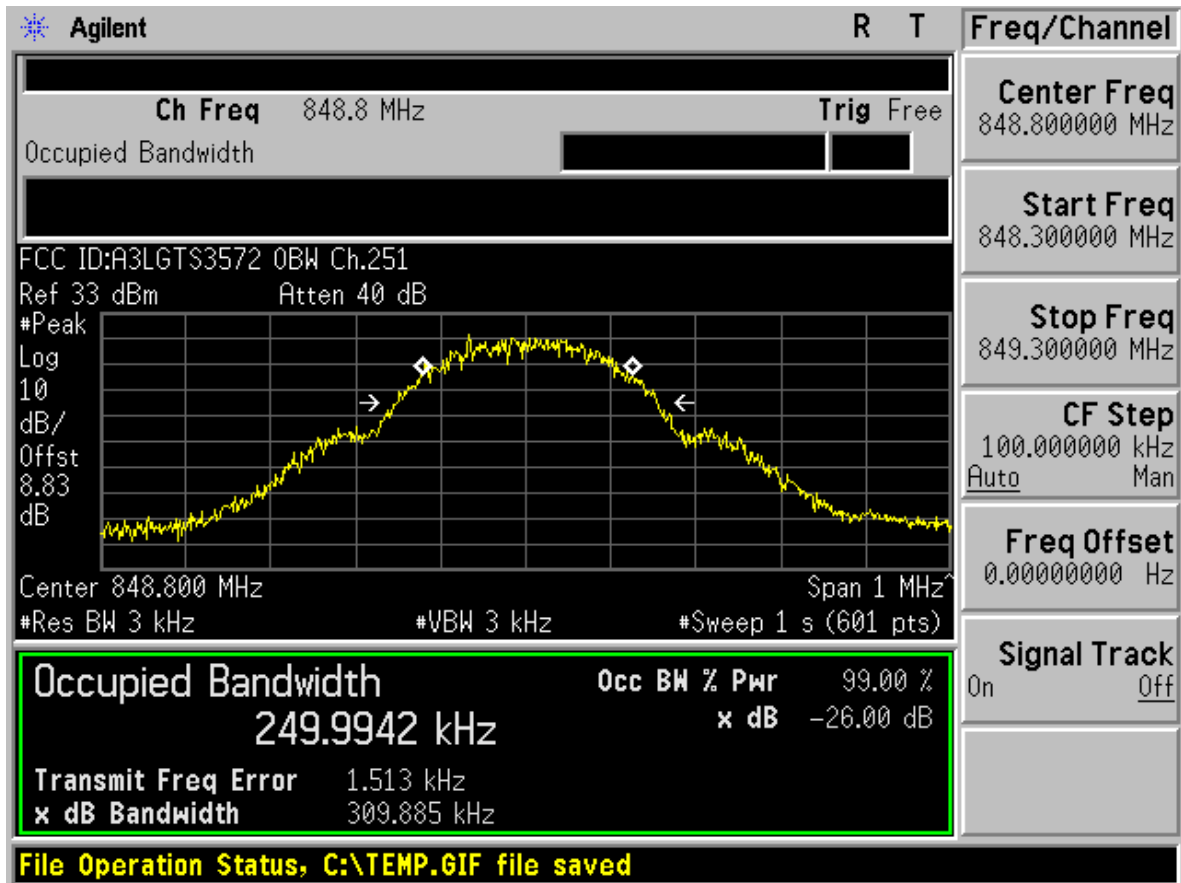

Measurement/Instrument Screen																													
Control	Transmit Power							TCH Parms																					
Transmit Power Setup								Downlink Traffic Power																					
								Traffic Band																					
								GSN850																					
								Traffic Channel																					
								128																					
								MS TX Level																					
								5																					
								Channel Mode Setup																					
								Return																					
								1 of 2																					
100 / 100 Single																													
Phase & Frequency Error																													
<table border="1"> <thead> <tr> <th></th> <th>Peak Phase °</th> <th>RMS Phase °</th> <th>Frequency Hz</th> </tr> </thead> <tbody> <tr> <td>Minimum</td> <td>3.07</td> <td>1.43</td> <td>-6.00</td> </tr> <tr> <td>Maximum</td> <td>5.63</td> <td>1.68</td> <td>5.61</td> </tr> <tr> <td>Average</td> <td>4.12</td> <td>1.55</td> <td>-1.17</td> </tr> <tr> <td>Pass/Fail</td> <td>Pass</td> <td>Pass</td> <td>Pass</td> </tr> </tbody> </table>											Peak Phase °	RMS Phase °	Frequency Hz	Minimum	3.07	1.43	-6.00	Maximum	5.63	1.68	5.61	Average	4.12	1.55	-1.17	Pass/Fail	Pass	Pass	Pass
	Peak Phase °	RMS Phase °	Frequency Hz																										
Minimum	3.07	1.43	-6.00																										
Maximum	5.63	1.68	5.61																										
Average	4.12	1.55	-1.17																										
Pass/Fail	Pass	Pass	Pass																										
100 / 100 Single																													
Active Cell Connected Sys Type: GSN																													
1 of 2 IntRef Offset R T 1 of 2																													
Swap Window Positions																													

Measurement/Instrument Screen																													
Control	Transmit Power							TCH Parms																					
Transmit Power Setup								Downlink Traffic Power																					
								Traffic Band																					
								GSN850																					
								Traffic Channel																					
								190																					
								MS TX Level																					
								5																					
								Channel Mode Setup																					
								Return																					
								1 of 2																					
100 / 100 Single																													
Phase & Frequency Error																													
<table border="1"> <thead> <tr> <th></th> <th>Peak Phase °</th> <th>RMS Phase °</th> <th>Frequency Hz</th> </tr> </thead> <tbody> <tr> <td>Minimum</td> <td>3.11</td> <td>1.38</td> <td>-7.52</td> </tr> <tr> <td>Maximum</td> <td>5.76</td> <td>1.65</td> <td>4.16</td> </tr> <tr> <td>Average</td> <td>3.93</td> <td>1.48</td> <td>-1.56</td> </tr> <tr> <td>Pass/Fail</td> <td>Pass</td> <td>Pass</td> <td>Pass</td> </tr> </tbody> </table>											Peak Phase °	RMS Phase °	Frequency Hz	Minimum	3.11	1.38	-7.52	Maximum	5.76	1.65	4.16	Average	3.93	1.48	-1.56	Pass/Fail	Pass	Pass	Pass
	Peak Phase °	RMS Phase °	Frequency Hz																										
Minimum	3.11	1.38	-7.52																										
Maximum	5.76	1.65	4.16																										
Average	3.93	1.48	-1.56																										
Pass/Fail	Pass	Pass	Pass																										
100 / 100 Single																													
Active Cell Connected Sys Type: GSN																													
1 of 2 IntRef Offset R T 1 of 2																													
Swap Window Positions																													

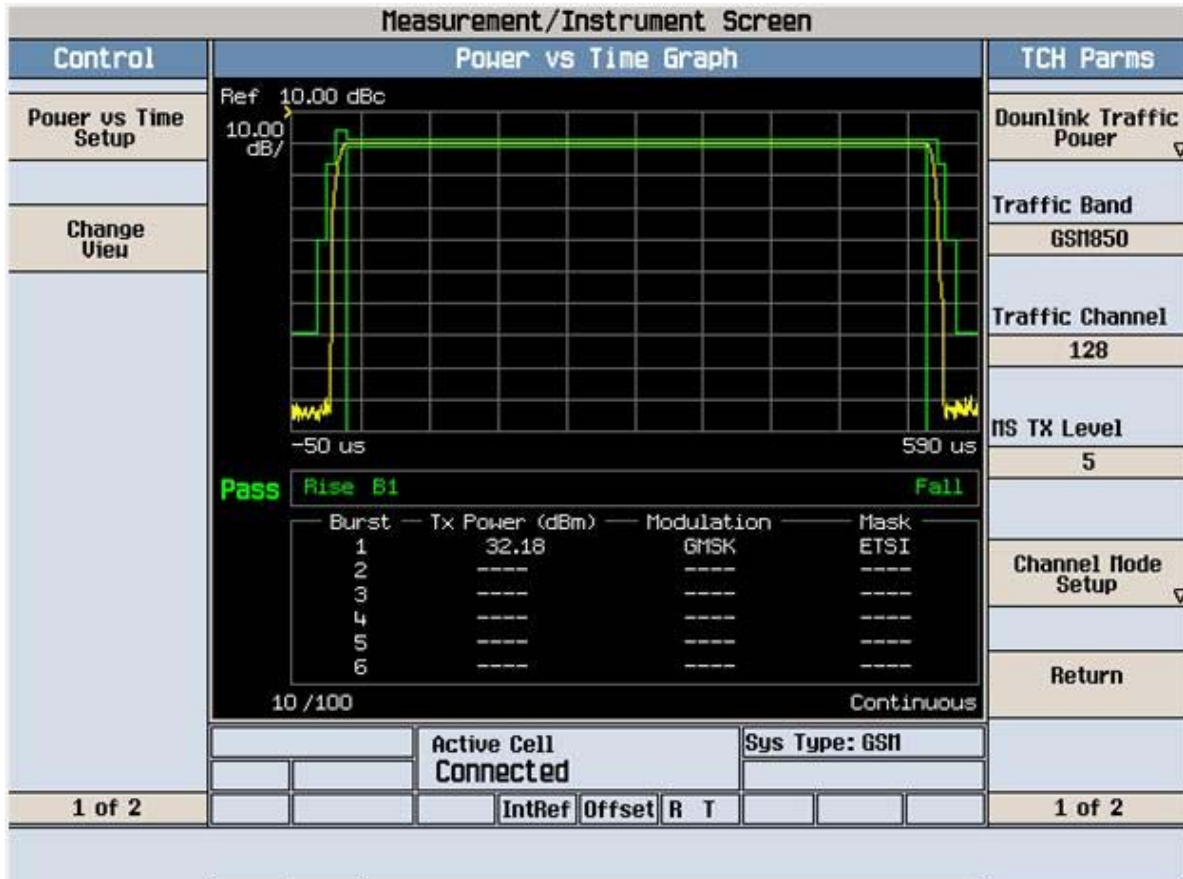
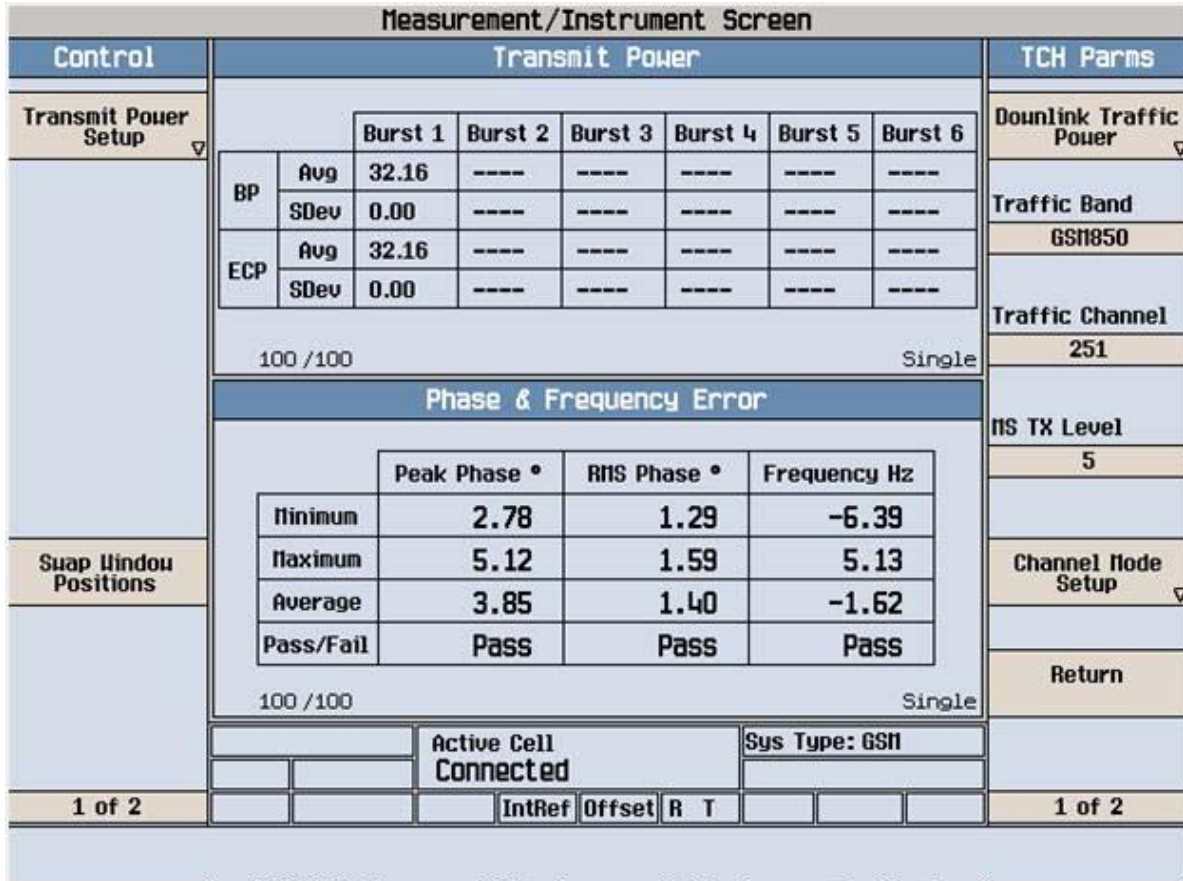

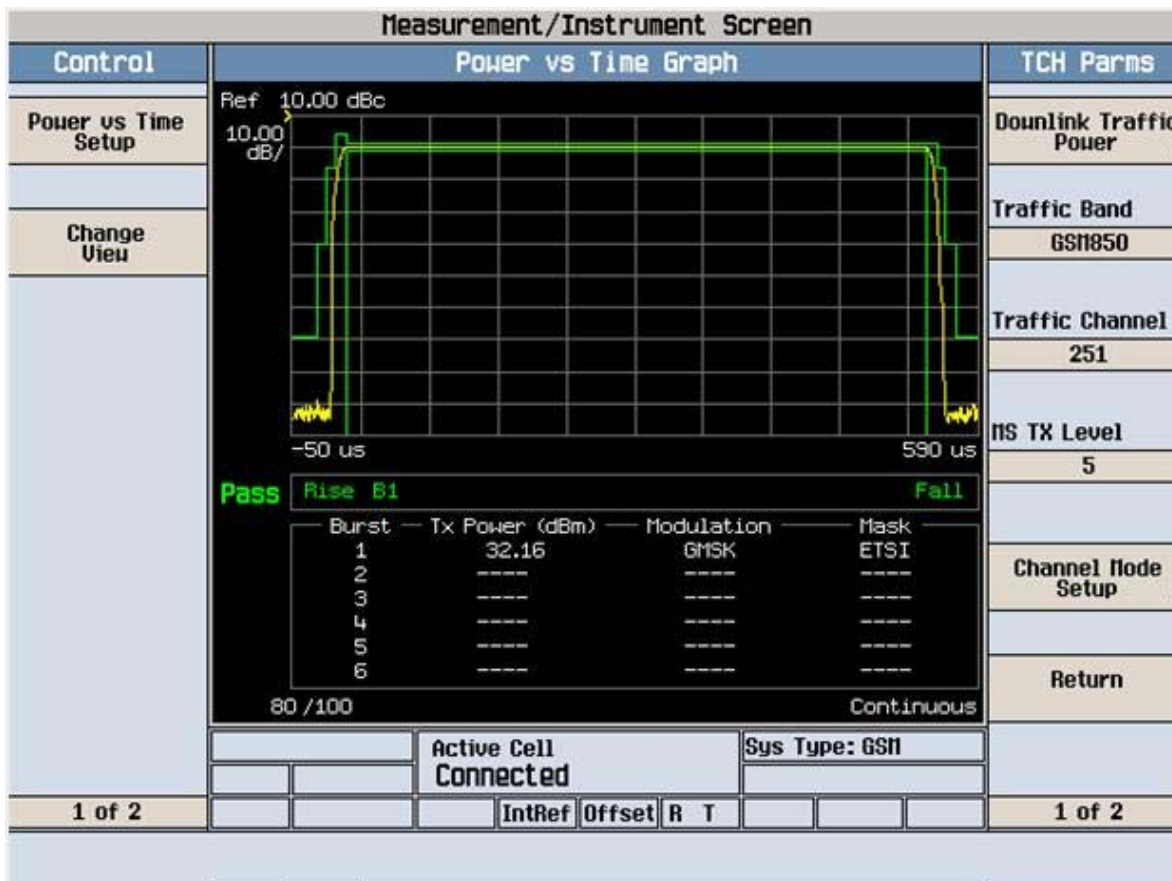
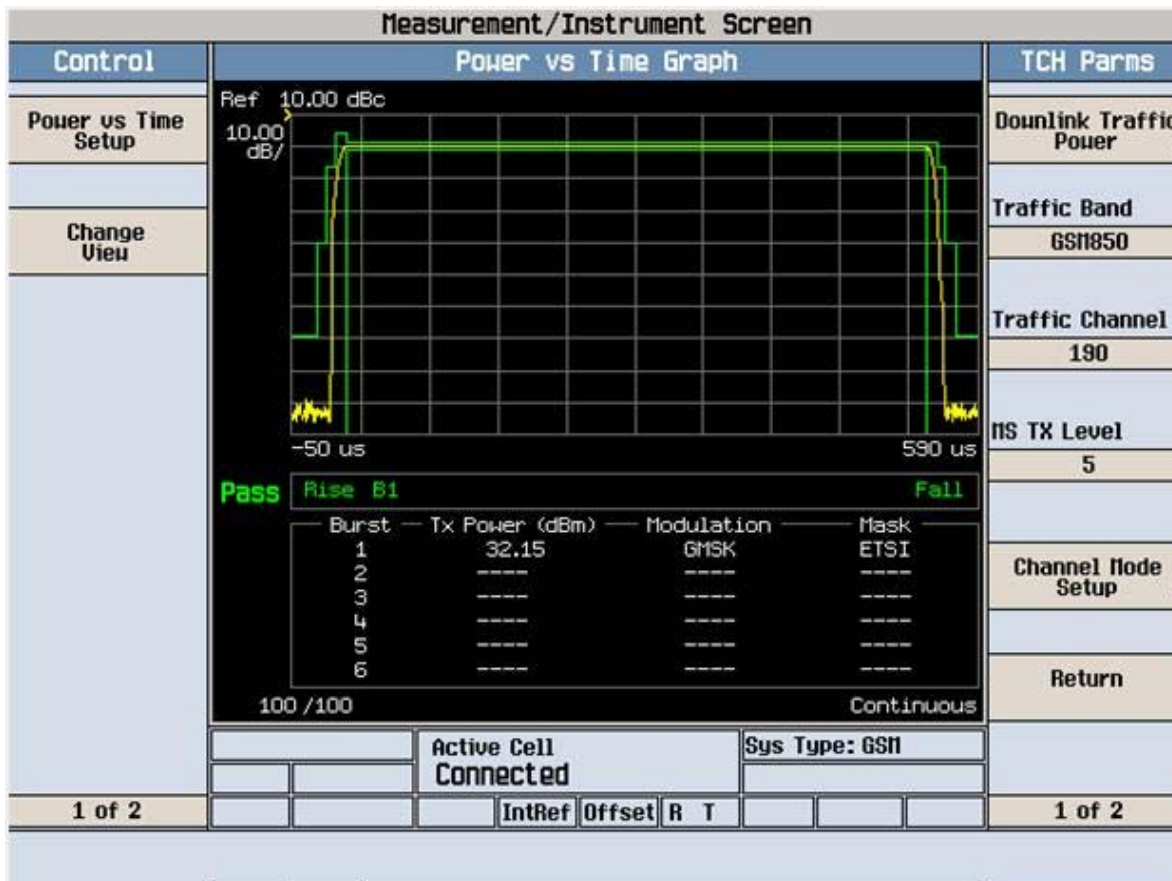

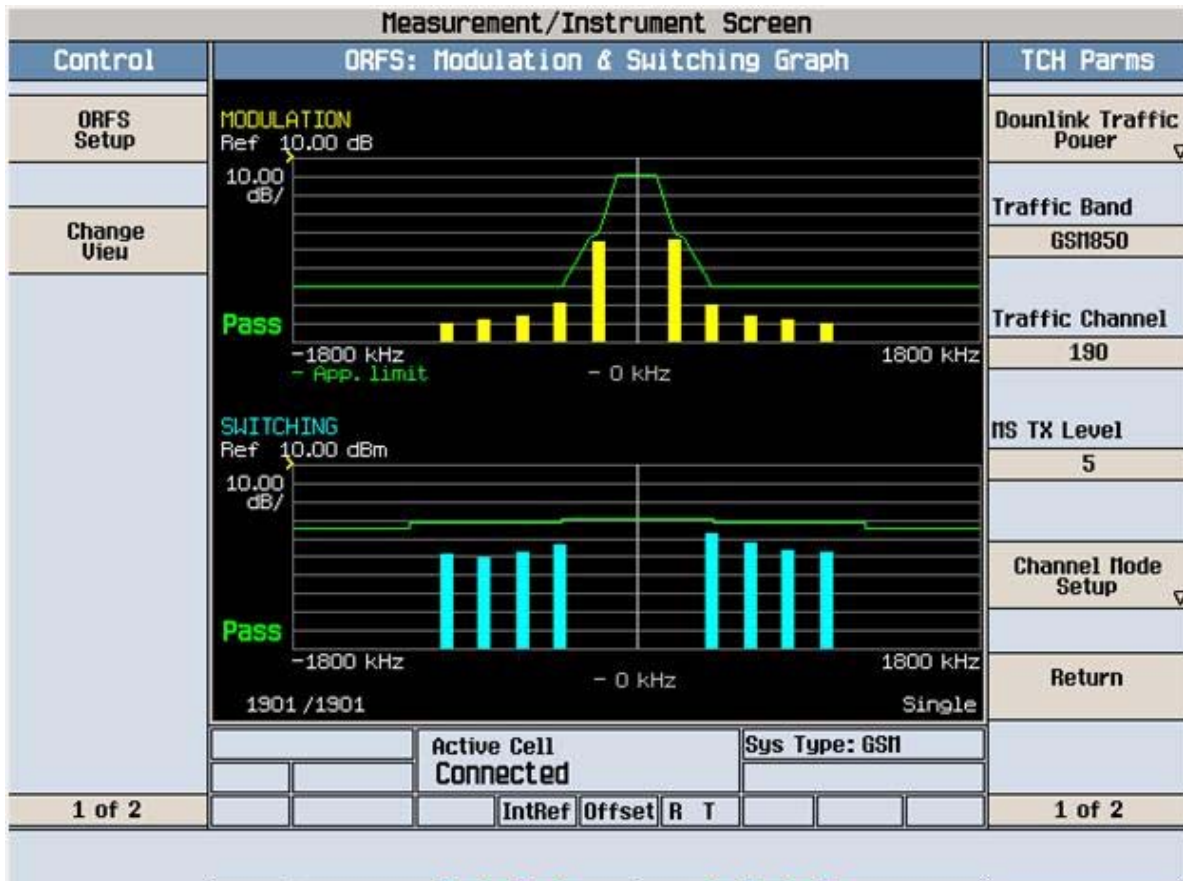
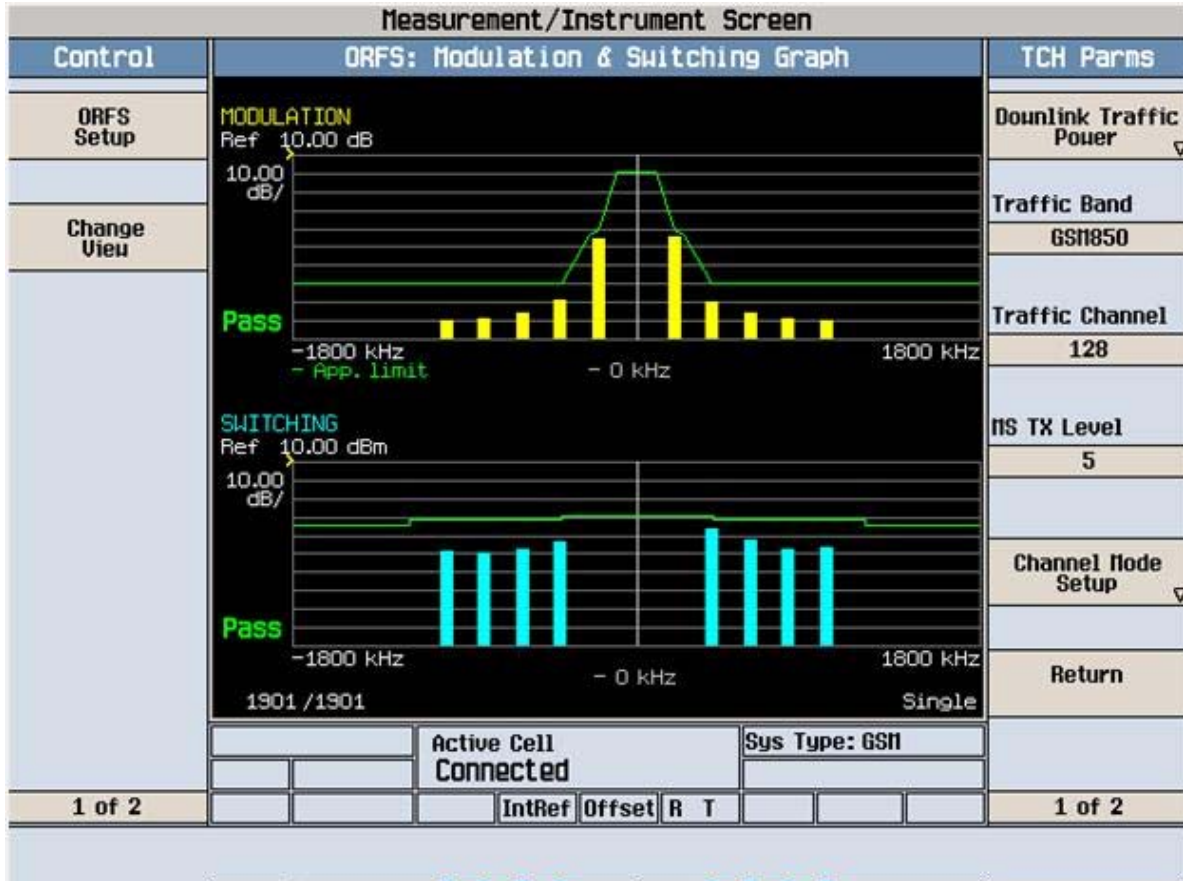

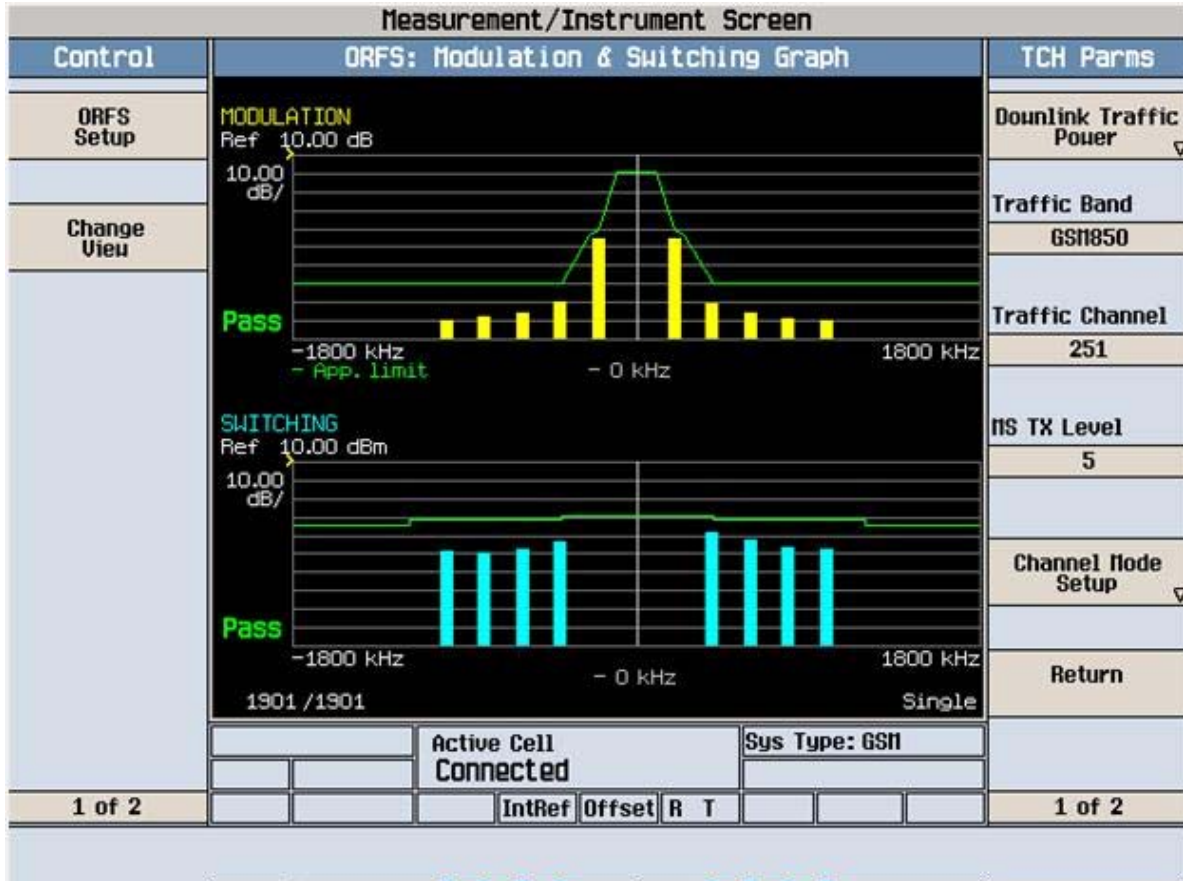

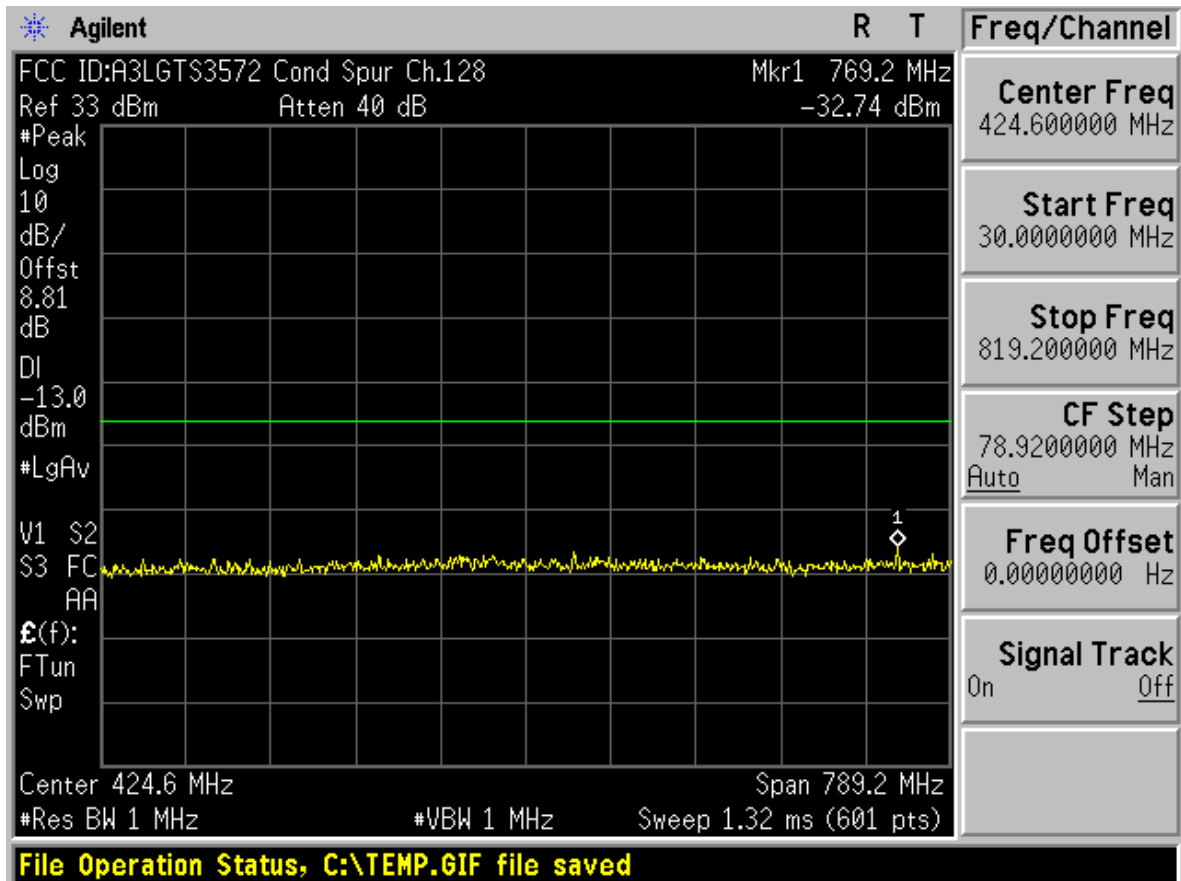
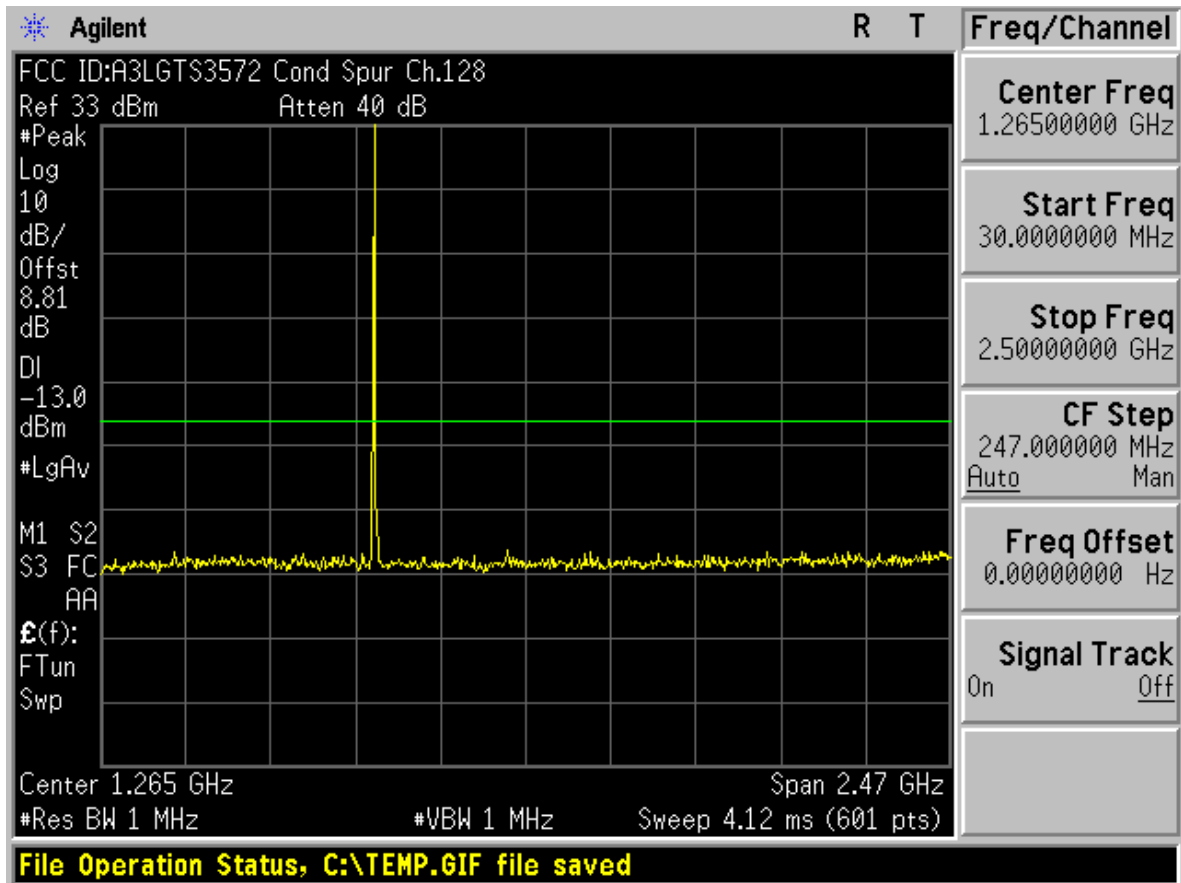

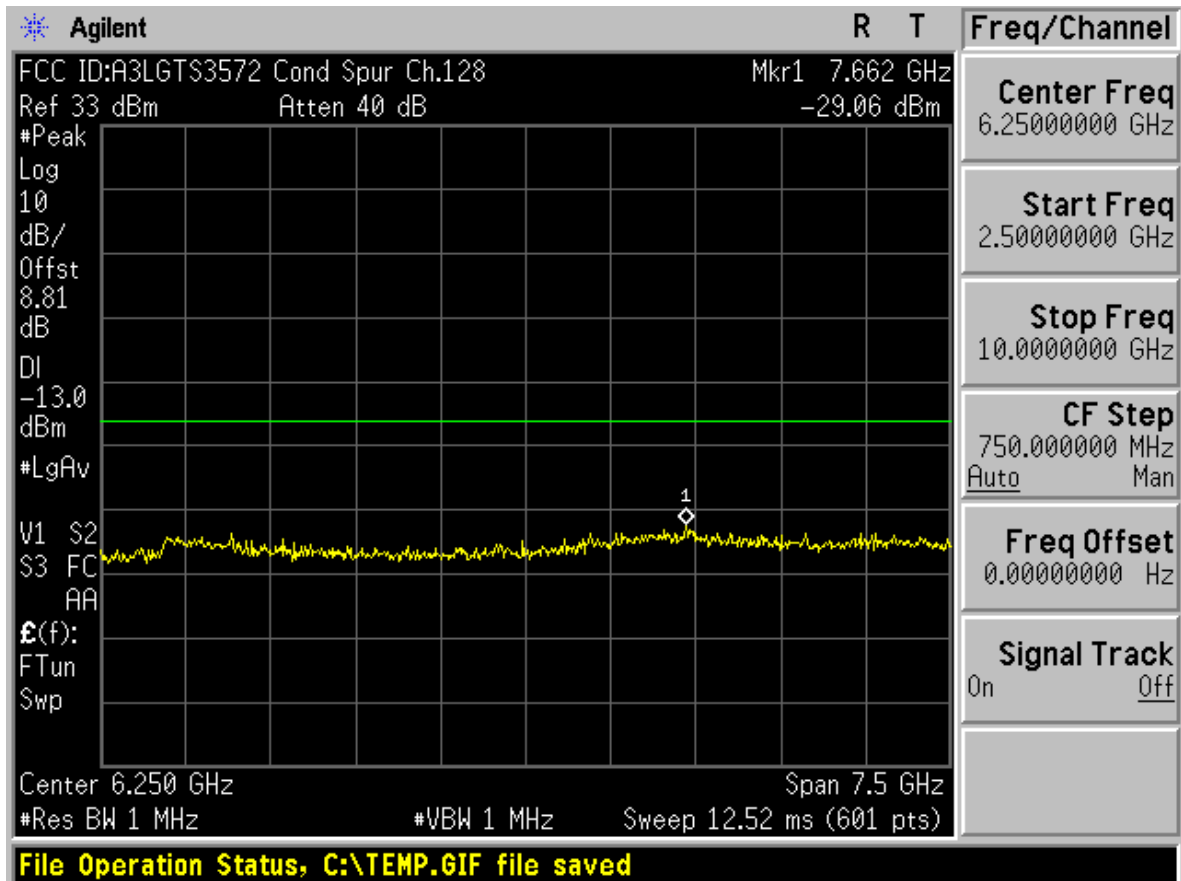
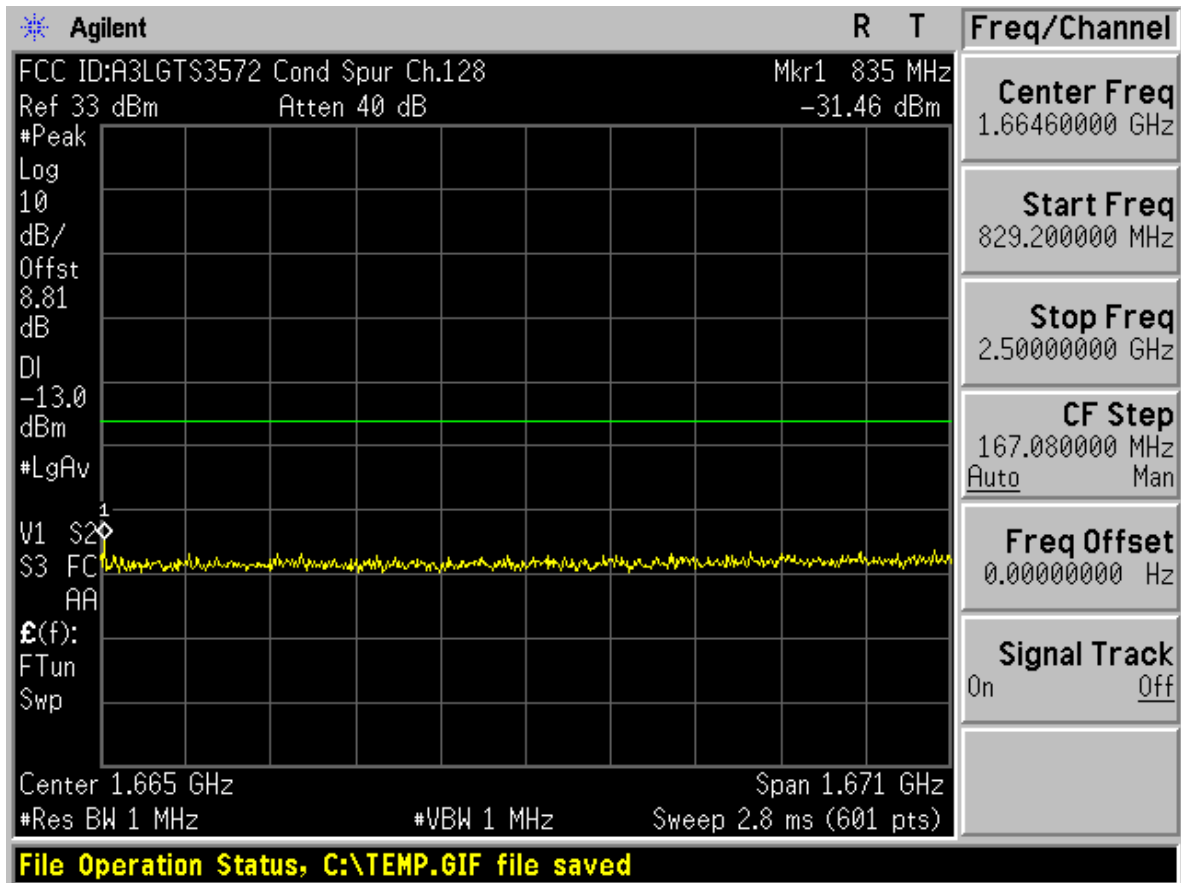

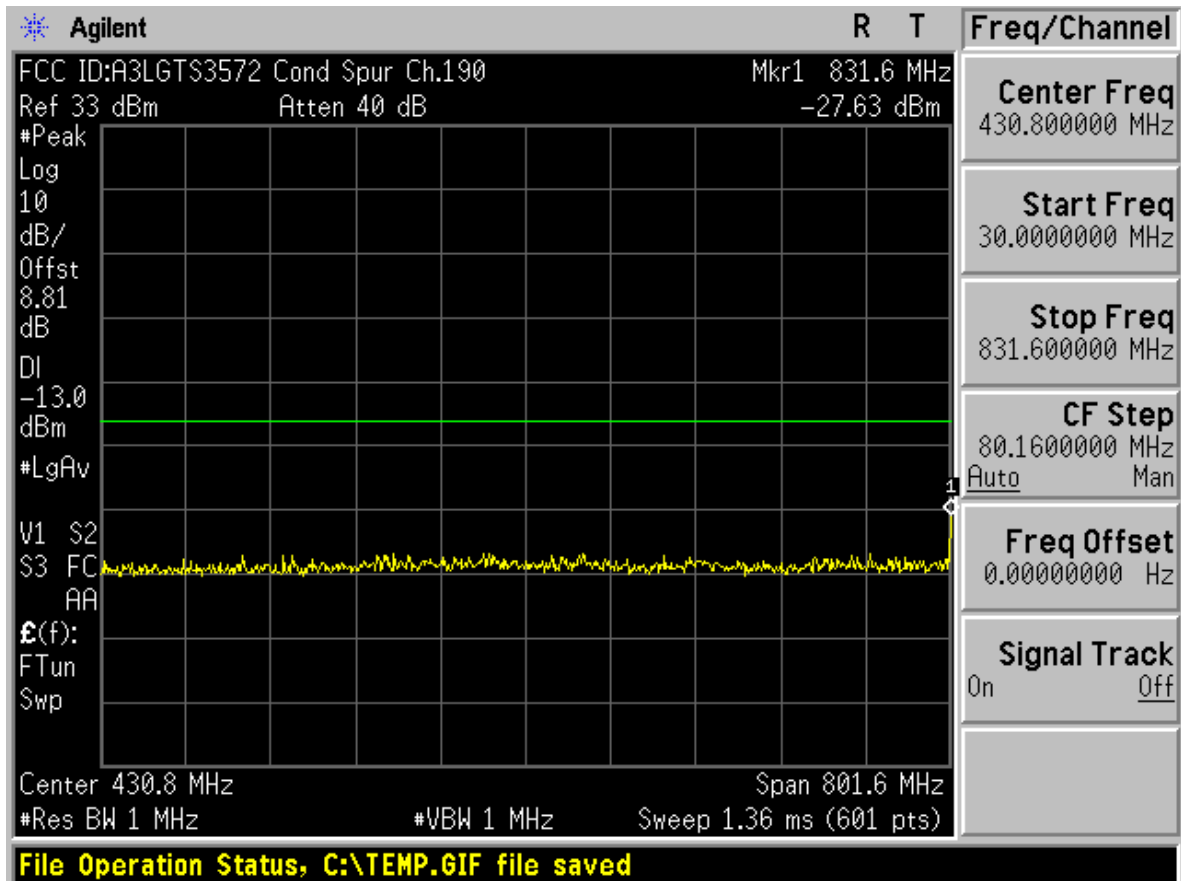
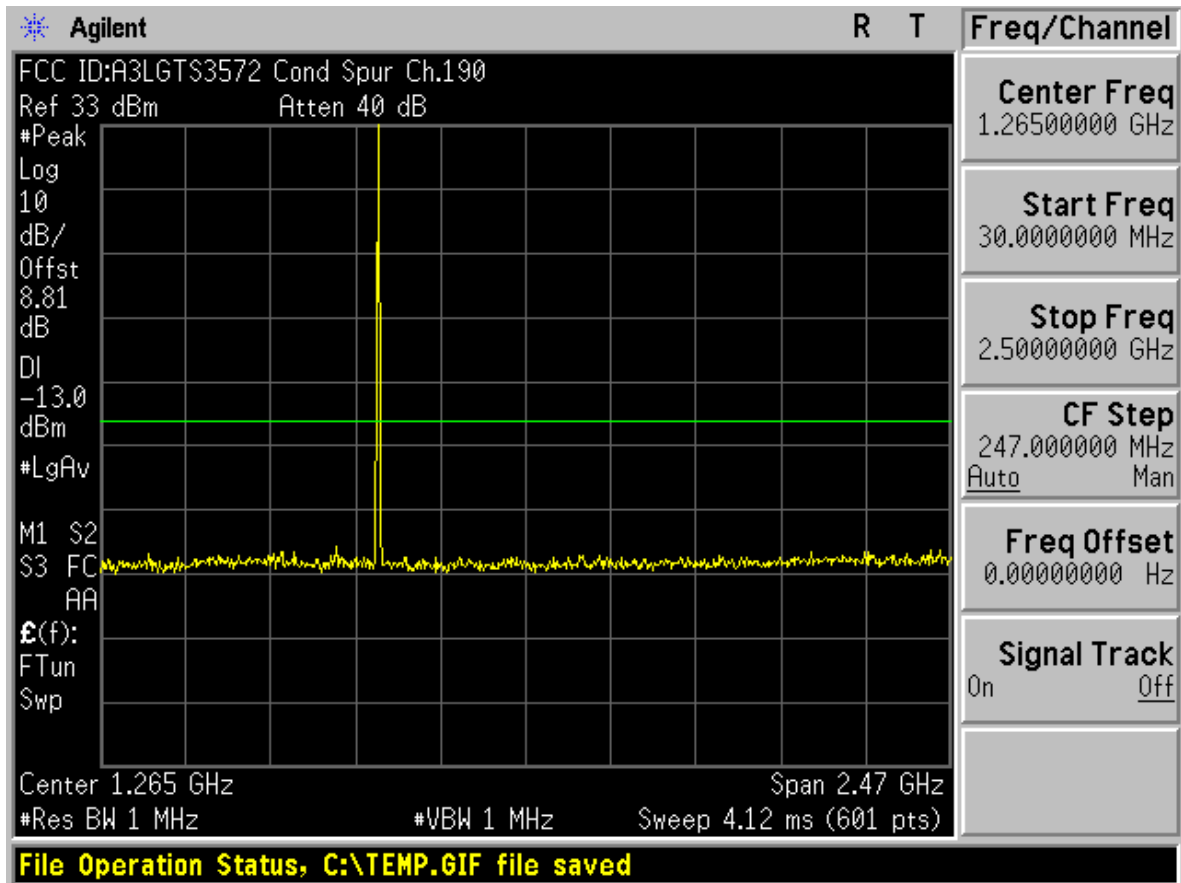

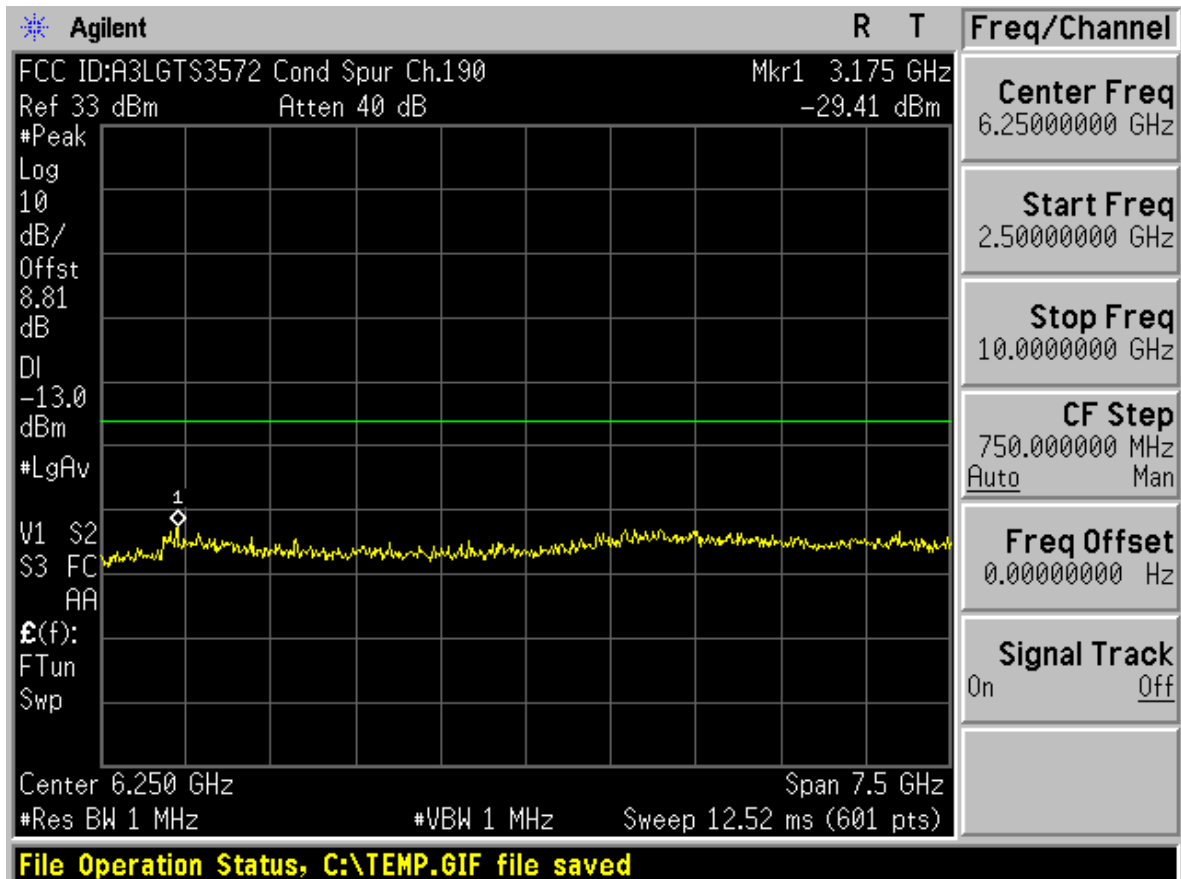
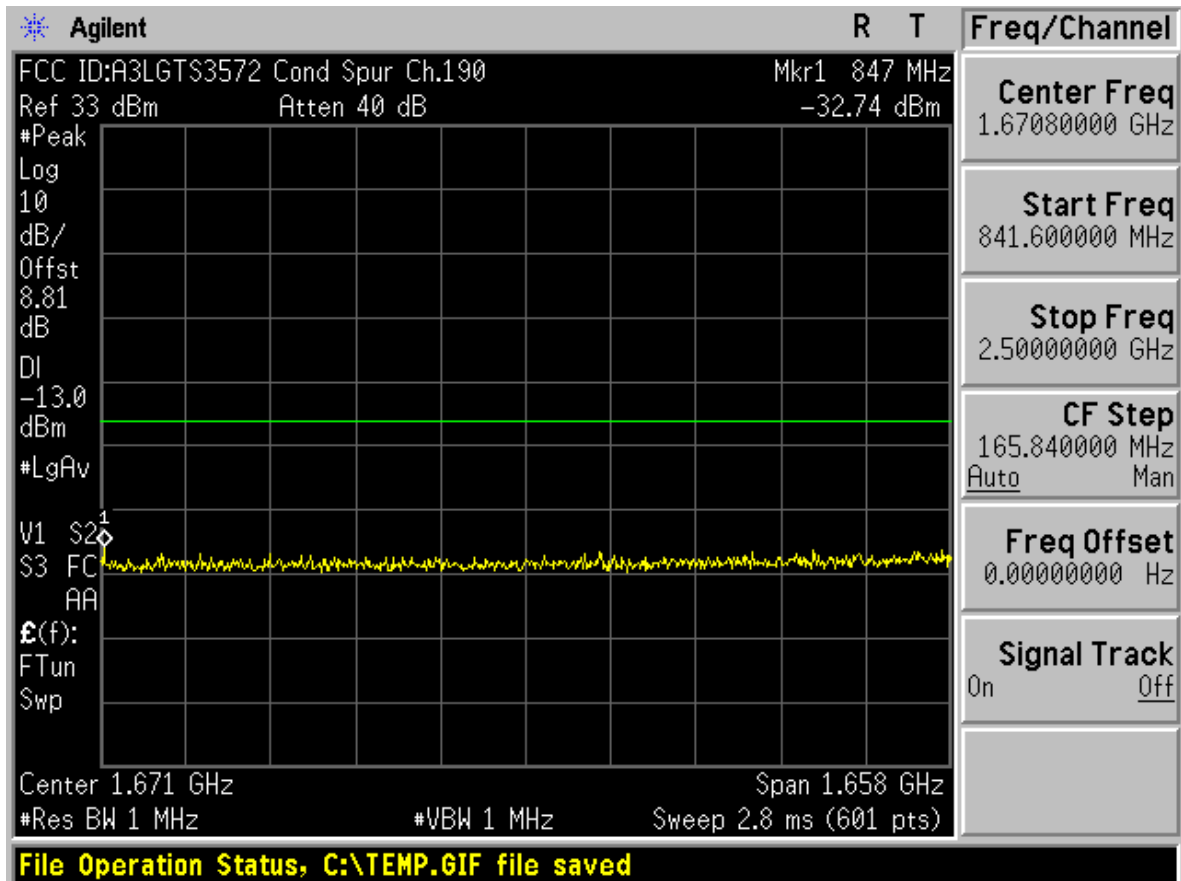

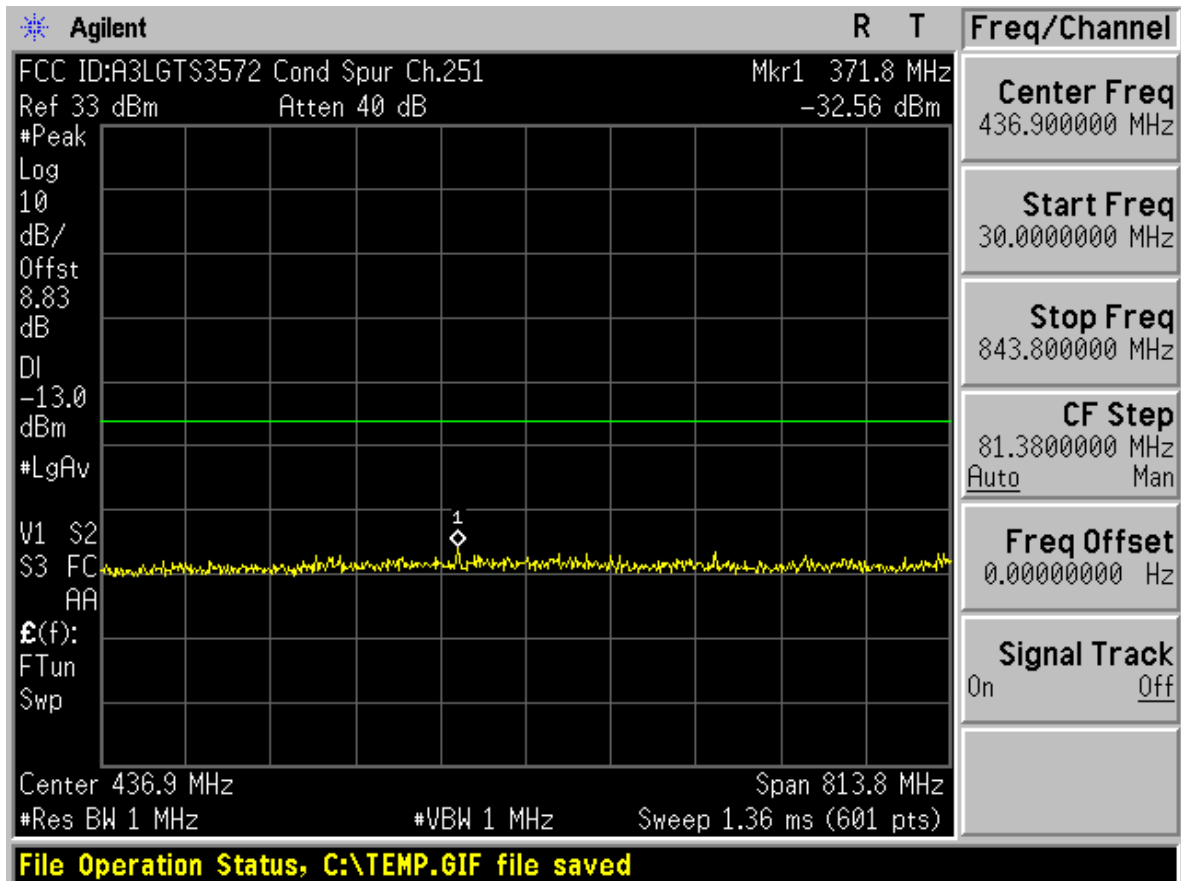
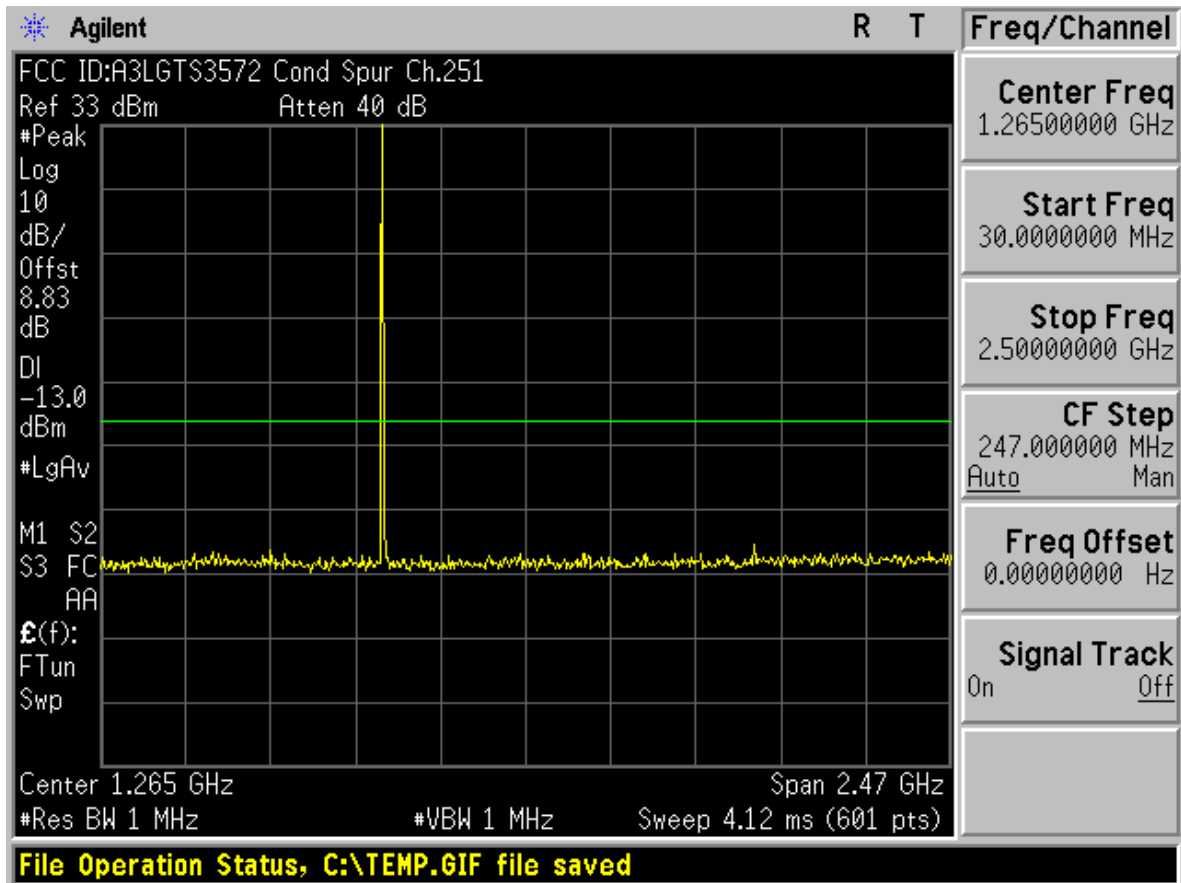

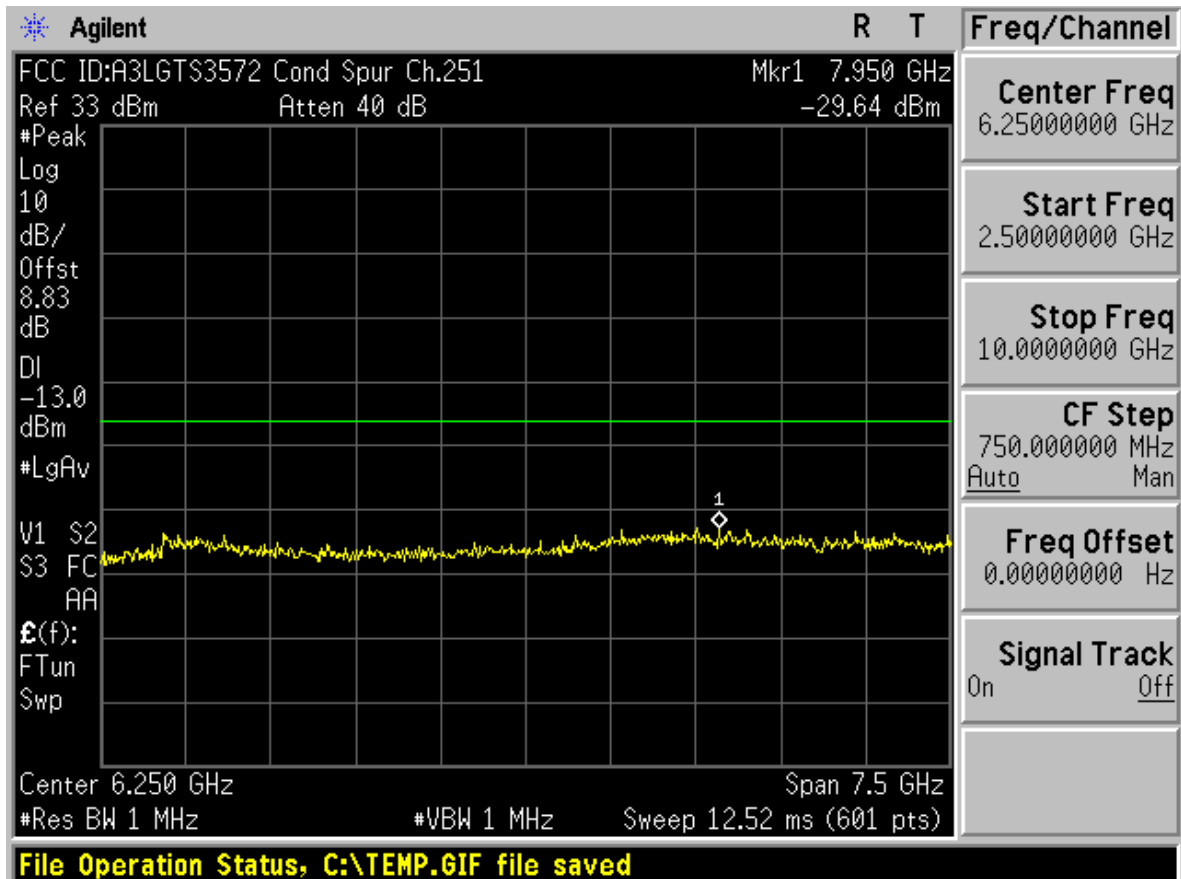
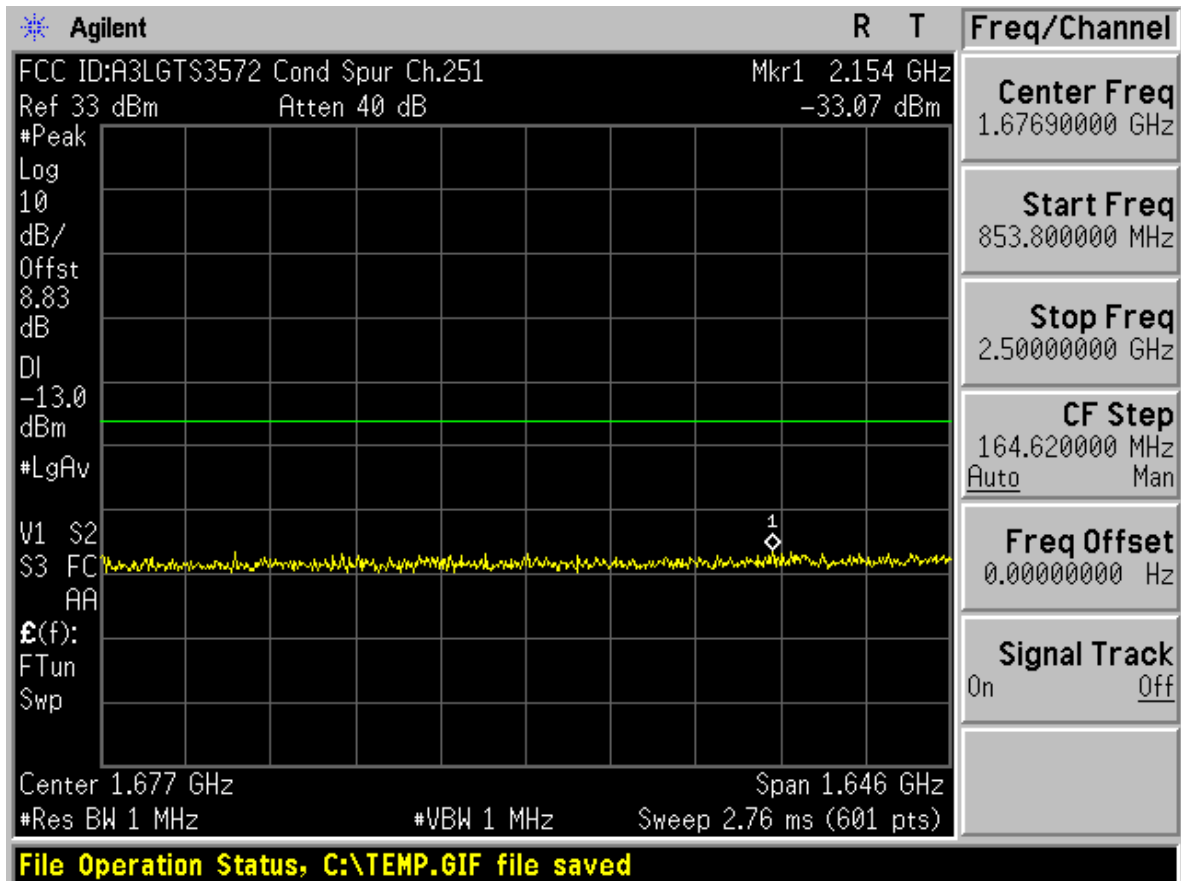

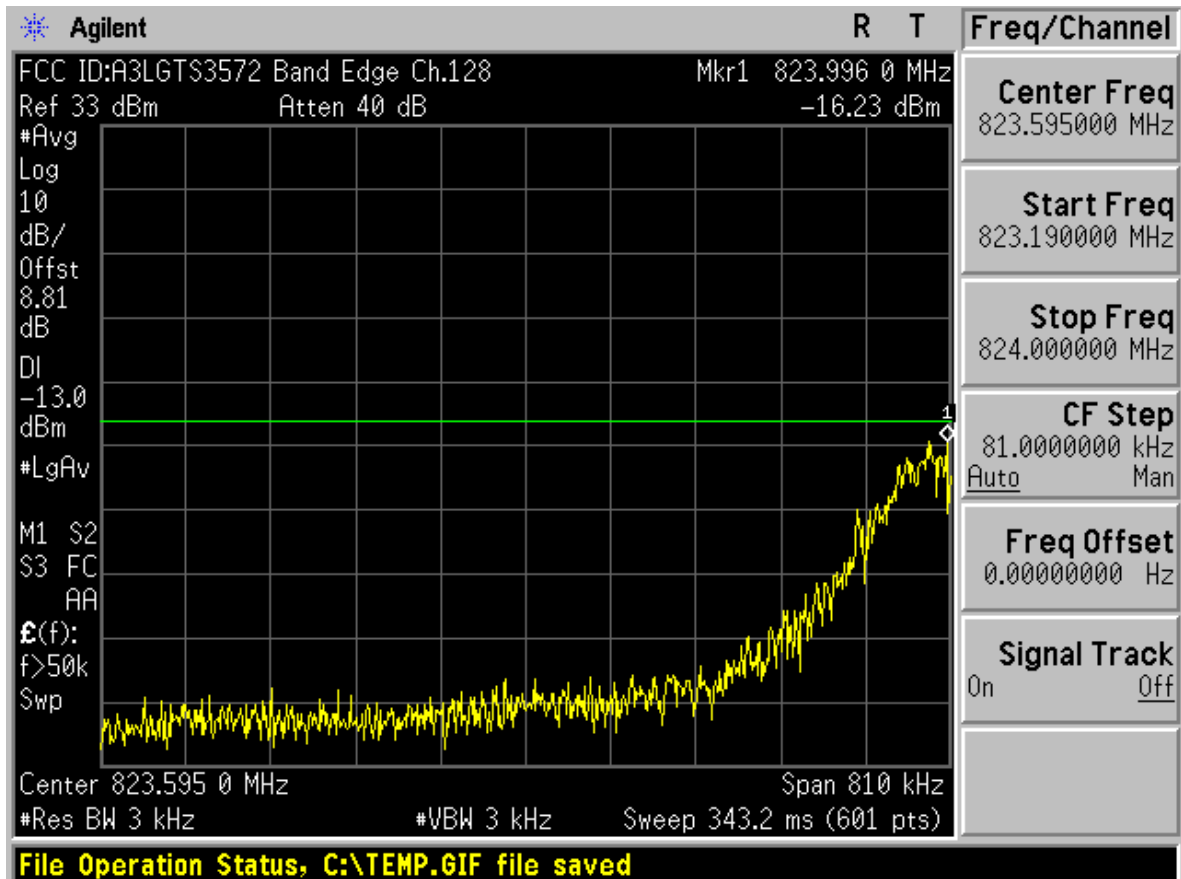
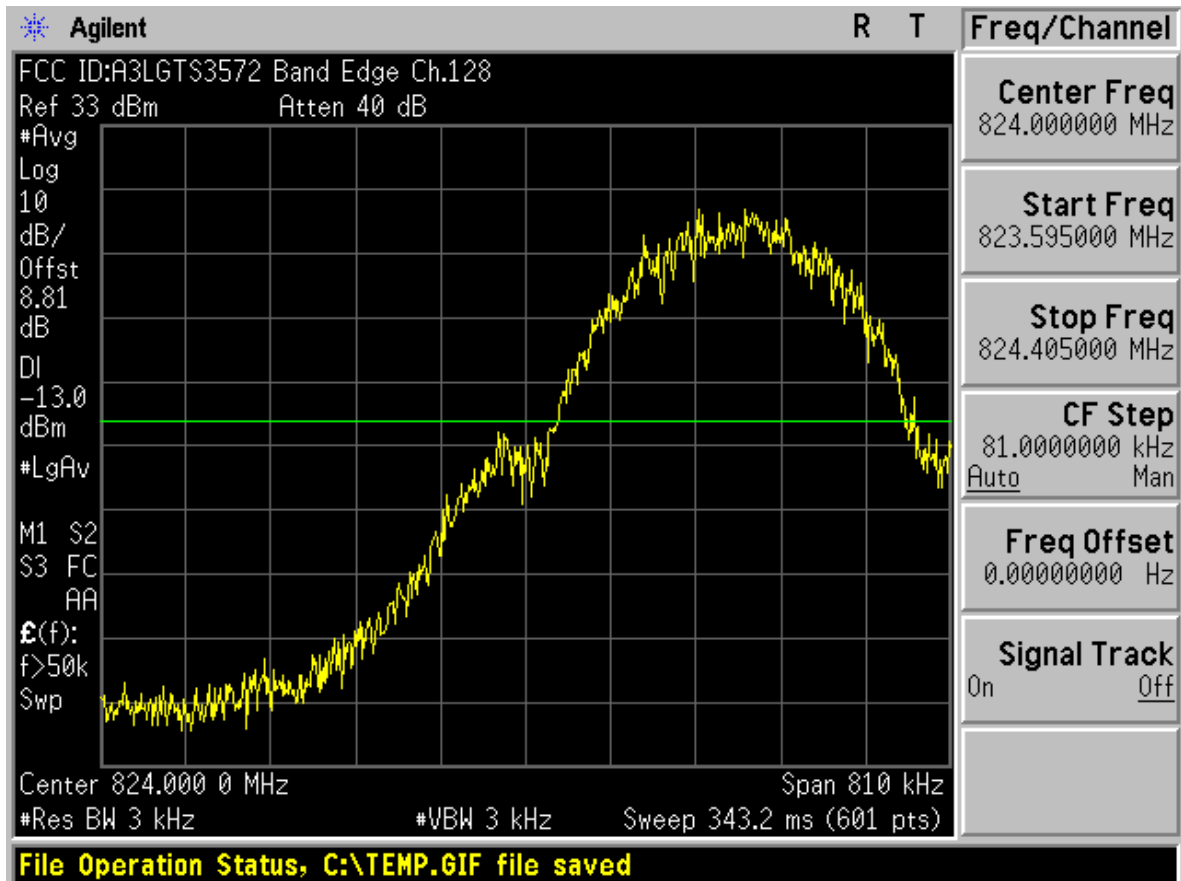

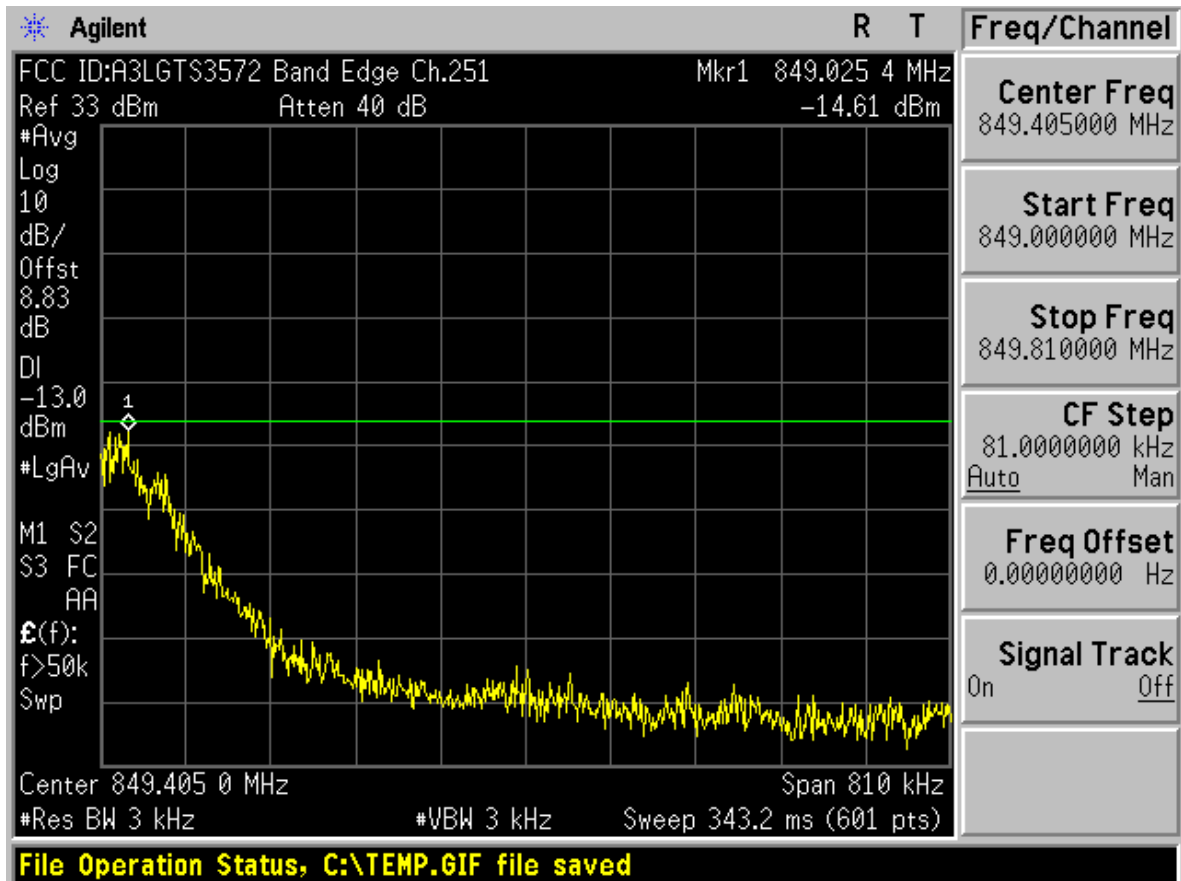
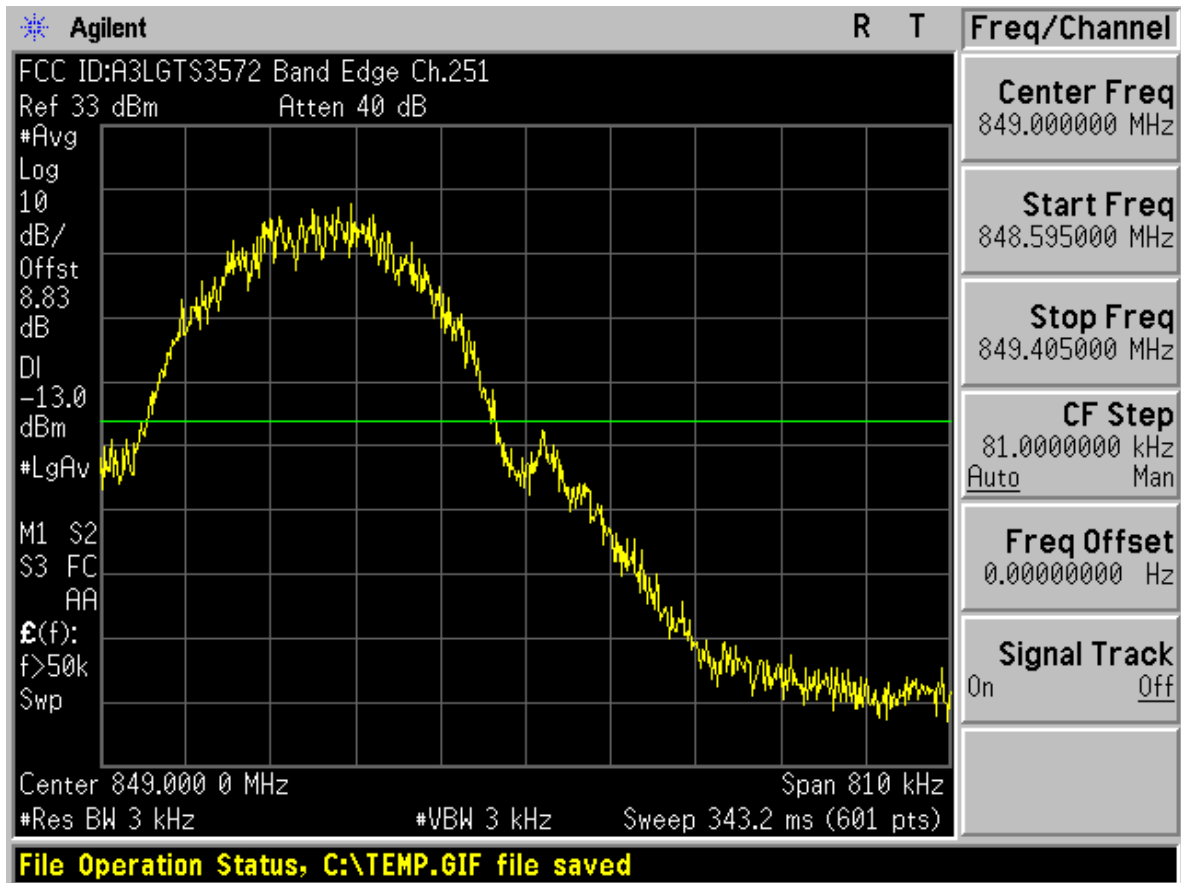

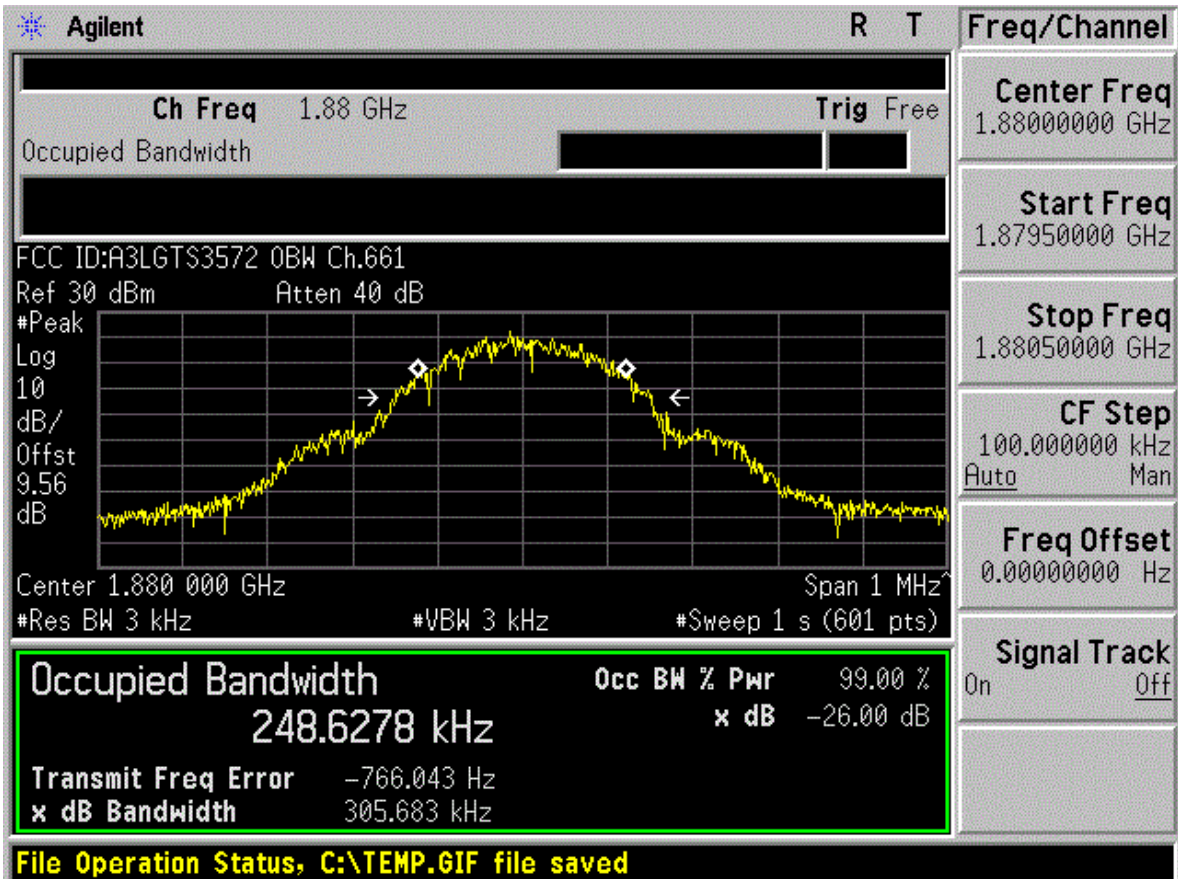
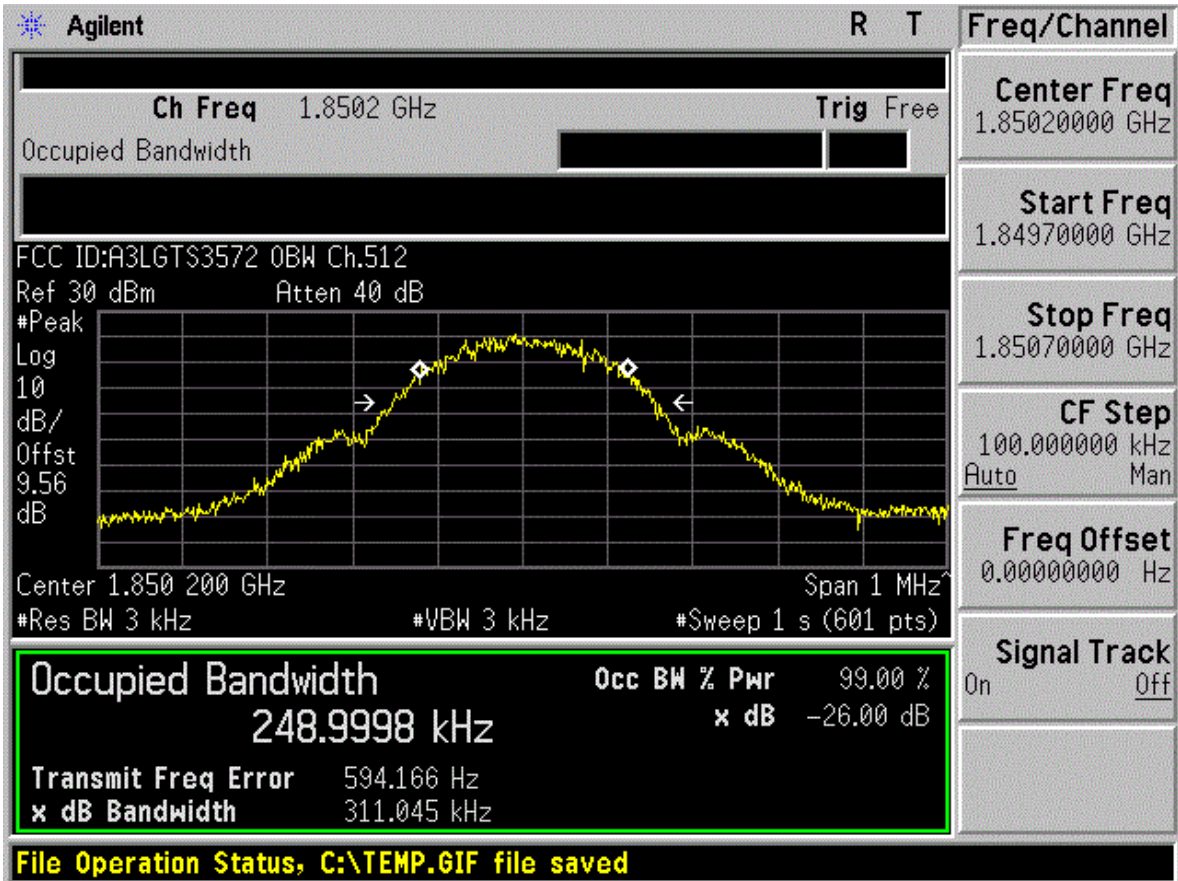

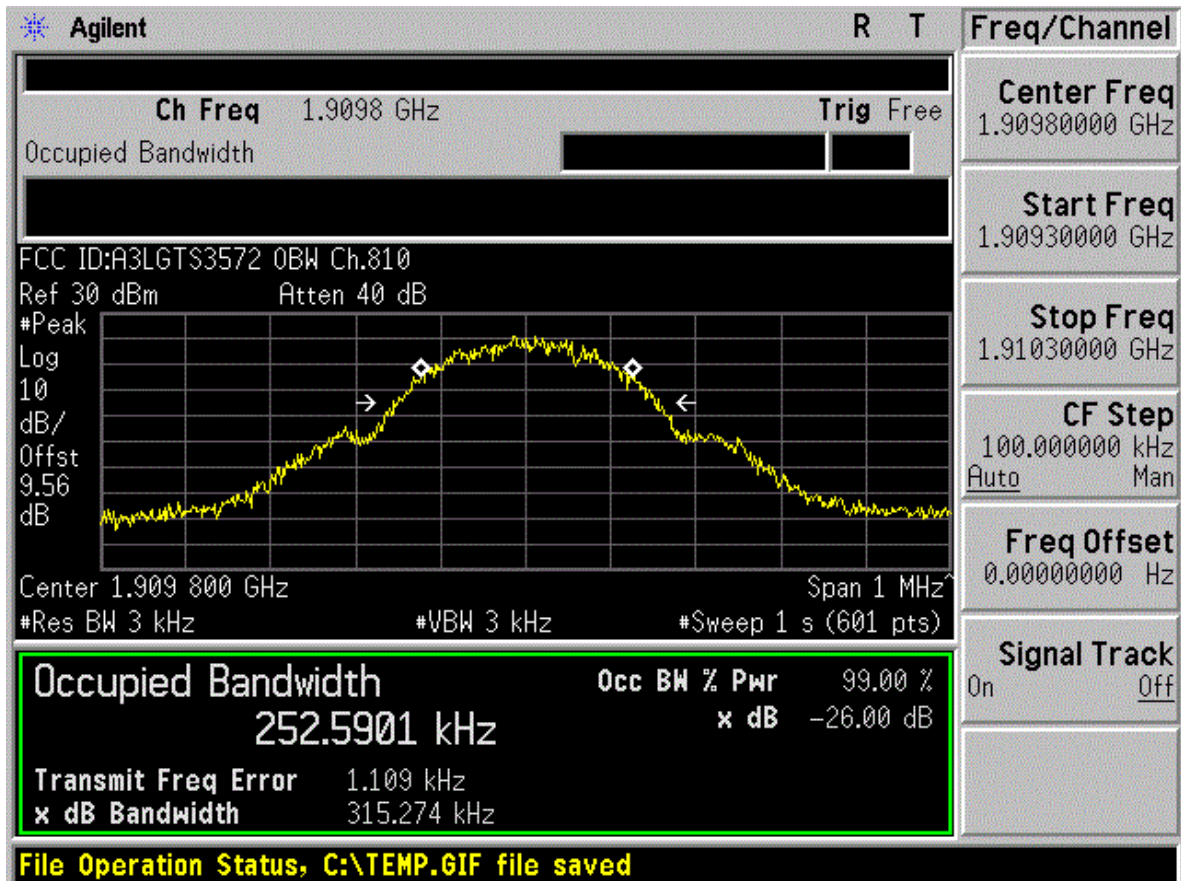

FCC ID : A3LGTS3572 Transmit Power 512CH

Measurement/Instrument Screen									
Control		Transmit Power						TCH Parms	
Transmit Power Setup	BP	Avg	29.74	----	----	----	----	Downlink Traffic Power	Traffic Band
		SDev	0.00	----	----	----	----		
	ECP	Avg	29.74	----	----	----	----	Traffic Channel	512
		SDev	0.00	----	----	----	----		
100 / 100		Single						Channel Mode Setup	
Snap Window Positions	Phase & Frequency Error								
			Peak Phase °		RMS Phase °		Frequency Hz		
	Minimum		4.28		1.59		-18.61		
	Maximum		9.51		2.04		3.76		
	Average		6.38		1.82		-7.70		
Pass/Fail		Pass		Pass		Pass			
100 / 100		Single						Return	
		Active Cell Connected				Sys Type: GSM			
1 of 2				IntRef	Offset	R T	1 of 2		

Measurement/Instrument Screen																																	
Control	Transmit Power							TCH Parms																									
Transmit Power Setup								Downlink Traffic Power																									
								Traffic Band																									
								PCS																									
								Traffic Channel																									
								661																									
								MS TX Level																									
								0																									
								Channel Mode Setup																									
								Return																									
								1 of 2																									
<table border="1"> <thead> <tr> <th colspan="4">Phase & Frequency Error</th> </tr> <tr> <th></th> <th>Peak Phase °</th> <th>RMS Phase °</th> <th>Frequency Hz</th> </tr> </thead> <tbody> <tr> <td>Minimum</td> <td>4.17</td> <td>1.56</td> <td>-14.12</td> </tr> <tr> <td>Maximum</td> <td>10.01</td> <td>2.14</td> <td>3.91</td> </tr> <tr> <td>Average</td> <td>6.31</td> <td>1.82</td> <td>-4.68</td> </tr> <tr> <td>Pass/Fail</td> <td>Pass</td> <td>Pass</td> <td>Pass</td> </tr> </tbody> </table>										Phase & Frequency Error					Peak Phase °	RMS Phase °	Frequency Hz	Minimum	4.17	1.56	-14.12	Maximum	10.01	2.14	3.91	Average	6.31	1.82	-4.68	Pass/Fail	Pass	Pass	Pass
Phase & Frequency Error																																	
	Peak Phase °	RMS Phase °	Frequency Hz																														
Minimum	4.17	1.56	-14.12																														
Maximum	10.01	2.14	3.91																														
Average	6.31	1.82	-4.68																														
Pass/Fail	Pass	Pass	Pass																														
<table border="1"> <tr> <td colspan="2"></td> <td colspan="3">Active Cell Connected</td> <td colspan="2">Sys Type: GSM</td> <td colspan="3"></td> </tr> </table>												Active Cell Connected			Sys Type: GSM																		
		Active Cell Connected			Sys Type: GSM																												
<table border="1"> <tr> <td colspan="2"></td> <td>IntRef</td> <td>Offset</td> <td>R</td> <td>T</td> <td colspan="4"></td> </tr> </table>												IntRef	Offset	R	T																		
		IntRef	Offset	R	T																												

Measurement/Instrument Screen																																	
Control	Transmit Power							TCH Parms																									
Transmit Power Setup								Downlink Traffic Power																									
								Traffic Band																									
								PCS																									
								Traffic Channel																									
								810																									
								MS TX Level																									
								0																									
								Channel Mode Setup																									
								Return																									
								1 of 2																									
<table border="1"> <thead> <tr> <th colspan="4">Phase & Frequency Error</th> </tr> <tr> <th></th> <th>Peak Phase °</th> <th>RMS Phase °</th> <th>Frequency Hz</th> </tr> </thead> <tbody> <tr> <td>Minimum</td> <td>4.37</td> <td>1.41</td> <td>-11.98</td> </tr> <tr> <td>Maximum</td> <td>9.02</td> <td>2.08</td> <td>0.99</td> </tr> <tr> <td>Average</td> <td>6.22</td> <td>1.79</td> <td>-5.27</td> </tr> <tr> <td>Pass/Fail</td> <td>Pass</td> <td>Pass</td> <td>Pass</td> </tr> </tbody> </table>										Phase & Frequency Error					Peak Phase °	RMS Phase °	Frequency Hz	Minimum	4.37	1.41	-11.98	Maximum	9.02	2.08	0.99	Average	6.22	1.79	-5.27	Pass/Fail	Pass	Pass	Pass
Phase & Frequency Error																																	
	Peak Phase °	RMS Phase °	Frequency Hz																														
Minimum	4.37	1.41	-11.98																														
Maximum	9.02	2.08	0.99																														
Average	6.22	1.79	-5.27																														
Pass/Fail	Pass	Pass	Pass																														
<table border="1"> <tr> <td colspan="2"></td> <td colspan="3">Active Cell Connected</td> <td colspan="2">Sys Type: GSM</td> <td colspan="3"></td> </tr> </table>												Active Cell Connected			Sys Type: GSM																		
		Active Cell Connected			Sys Type: GSM																												
<table border="1"> <tr> <td colspan="2"></td> <td>IntRef</td> <td>Offset</td> <td>R</td> <td>T</td> <td colspan="4"></td> </tr> </table>												IntRef	Offset	R	T																		
		IntRef	Offset	R	T																												

