

TEST REPORT

of

FCC Part 15 Subpart C §15.247

FCC ID: A3LGTS3572

Equipment Under Test : Mobile Phone
Model Name : GT-S3572 (Alt: GT-S3570)
Serial No. : N/A
Applicant : SAMSUNG ELECTRONICS CO., LTD
Manufacturer : SAMSUNG ELECTRONICS CO., LTD
Date of Test(s) : 2012.06.19 ~ 2012.06.27
Date of Issue : 2012.07.05

In the configuration tested, the EUT complied with the standards specified above.

Tested By:

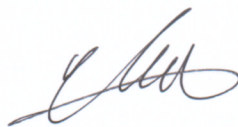

Date

2012.07.05

Harim Lee

Approved By:



Date

2012.07.05

Feel Jeong

The results shown in this test report refer only to the sample(s) tested unless otherwise stated. This test report cannot be reproduced, except in full, without prior written permission of the Company.

INDEX

Table of contents

1. General information -----	3
2. Transmitter radiated spurious emissions and conducted spurious emission -----	6
3. 6 dB bandwidth -----	20
4. Maximum peak output power -----	25
5. Power Spectral Density -----	27
6. Transmitter AC Power Line Conducted Emission-----	32
7. Antenna Requirement -----	37

The results shown in this test report refer only to the sample(s) tested unless otherwise stated. This test report cannot be reproduced, except in full, without prior written permission of the Company.

1. General Information

1.1. Testing Laboratory

SGS Korea Co., Ltd. (Gunpo Laboratory)

- 413-15, Gomae-Dong Giheung-Gu, Yongin-Si, Gyeonggi-Do, South Korea.
- Wireless Div.3FL, 18-34, Sanbon-dong, Gunpo-si, Gyeonggi-do, Korea 435-040

www.ee.sgs.com/korea

Telephone : +82 31 428 5700

FAX : +82 31 427 2371

1.2. Details of Applicant

Applicant : SAMSUNG ELECTRONICS CO., LTD.
 Address : 416, Maetan-3dong, Yeongtong, Suwon, Gyeonggi, Korea
 Contact Person : Choi, Kang-Hyup
 Phone No. : +82 10 9117 3832

1.3. Description of EUT

Kind of Product	Mobile Phone
Model Name	GT-S3572 (Alt: GT-S3570)
Serial Number	N/A
Power Supply	DC 3.7 V
Frequency Range	2 412 MHz ~ 2 462 MHz (11b/g)
Modulation Technique	DSSS, OFDM
Number of Channels	11 channels (11b/g)
Antenna Type	Internal type
Antenna Gain	-0.75 dBi

1.4. Declaration by the manufacturer

- WLAN & BT do not transmit simultaneously.

1.5. Alternative model name

Model name	Information
GT-S3572	- Basic model
GT-S3570	- Same to basic model but it is different in the following - Modify S/W version - Use only one SIM connector

The results shown in this test report refer only to the sample(s) tested unless otherwise stated. This test report cannot be reproduced, except in full, without prior written permission of the Company.

1.6. Test Equipment List

Equipment	Manufacturer	Model	S/N	Cal Date	Cal Interval	Cal Due.
Signal Generator	R&S	SMR40	100272	Jul, 15, 2012	Annual	Jul, 15, 2013
Signal Generator	R&S	SMBV100A	255834	Sep, 20, 2011	Annual	Sep, 20, 2012
Spectrum Analyzer	Agilent	E4440A	MY43362142	Mar. 29, 2012	Annual	Mar. 29, 2013
Attenuator	AEROFLEX / INMET	18N-20dB	2	Apr. 02, 2012	Annual	Apr. 02, 2013
Low Pass Filter	Mini-Circuits	NLP-1200+	V9500401023-3	Aug. 22, 2011	Annual	Aug. 22, 2012
High Pass Filter	Wainwright	WHKX3.0/18G-6SS	4	Sep. 14, 2011	Annual	Sep. 14, 2012
Power Sensor	R & S	NRP-Z81	100669	Apr. 03. 2012	Annual	Apr. 03. 2013
Power divider	AEROFLEX	1575	1537	Sep. 27. 2011	Annual	Sep. 27. 2012
DC Power Supply	Agilent	6553A	MY40000695	Jul. 04, 2011	Annual	Jul. 04, 2012
Preamplifier	H.P.	8447F	2944A03909	Jul. 04, 2011	Annual	Jul. 04, 2012
Preamplifier	R&S	SCU18	10117	Jan. 02, 2012	Annual	Jan. 02, 2013
Preamplifier	MITEQ Inc.	JS44-18004000-35-8P	1546891	Jul. 04, 2011	Annual	Jul. 04, 2012
Test Receiver	R&S	ESU26	100109	Feb. 21, 2012	Annual	Feb. 21, 2013
Bilog Antenna	SCHWARZBECK MESSELEKTRONIK	VULB9163	396	May 12, 2011	Biennial	May 12, 2013
Horn Antenna	R&S	HF906	100326	Nov. 23, 2011	Biennial	Nov. 23, 2013
Horn Antenna	SCHWARZBECK MESSELEKTRONIK	BBHA9170	BBHA9170431	May 15, 2012	Biennial	May 15, 2014
Antenna Master	INN-CO	MM4000	N/A	N.C.R.	N/A	N.C.R.
Turn Table	INN-CO	DS 1200S	N/A	N.C.R.	N/A	N.C.R.
EMI Test Receiver	R&S	ESHSI0	863365/018	Jul. 07, 2011	Annual	Jul. 07, 2012
Two-Line V-Network	R&S	ENV216	100190	Jan. 09, 2012	Annual	Jan. 09, 2013
Anechoic Chamber	SY Corporation	L x W x H (6.5 m x 3.5 m x 3.5 m)	N/A	N.C.R.	N/A	N.C.R.
Anechoic Chamber	SY Corporation	L x W x H (9.6 m x 6.4 m x 6.4 m)	N/A	N.C.R.	N/A	N.C.R.

► Support equipment

Description	Manufacturer	Model	Serial Number
N/A	-	-	-

The results shown in this test report refer only to the sample(s) tested unless otherwise stated. This test report cannot be reproduced, except in full, without prior written permission of the Company.

1.7. Summary of Test Results

The EUT has been tested according to the following specifications:

APPLIED STANDARD: FCC Part15 Subpart C § 15.247		
FCC Part Section(s)	Test Item(s)	Result
15.205 15.209 15.247(d)	Transmitter Radiated Spurious Emissions Conducted Spurious Emission	Complied
15.247(a)(2)	6 dB Bandwidth	Complied
15.247(b)(3)	Maximum Peak Output Power	Complied
15.247(e)	Power Spectral Density	Complied
15.207	Transmitter AC Power Line Conducted Emission	Complied

1.8. Test Procedure(s)

The measurement procedures described in the American National Standard for Methods of Measurement of Radio-Noise Emission from Low-Voltage Electrical and Electronic Equipment in the Range of 9 kHz to 40 GHz (ANSI C63.4-2003) and the guidance provided in KDB 558074 were used in the measurement of the DUT.

1.9. Sample calculation

Where relevant, the following sample calculation is provided:

1.9.1. Conducted test

Offset value (dB) = Power Divider (dB) + Attenuator (dB) + Cable loss (dB)

1.9.2. Radiation test

Field strength level(dB μ V/m) = Measured level(dB μ V) + Antenna factor(dB) + Cable loss(dB) - amplifier gain(dB)

1.10. Test report revision

Revision	Report number	Description
0	F690501/RF-RTL005613	Initial
1	F690501/RF-RTL005613-1	Add the alternative model.

The results shown in this test report refer only to the sample(s) tested unless otherwise stated. This test report cannot be reproduced, except in full, without prior written permission of the Company.

2. Transmitter Radiated Spurious Emissions and Conducted Spurious Emission

2.1. Test Setup

2.1.1. Transmitter Radiated Spurious Emissions

The diagram below shows the test setup that is utilized to make the measurements for emission from 30 MHz to 1 GHz Emissions.

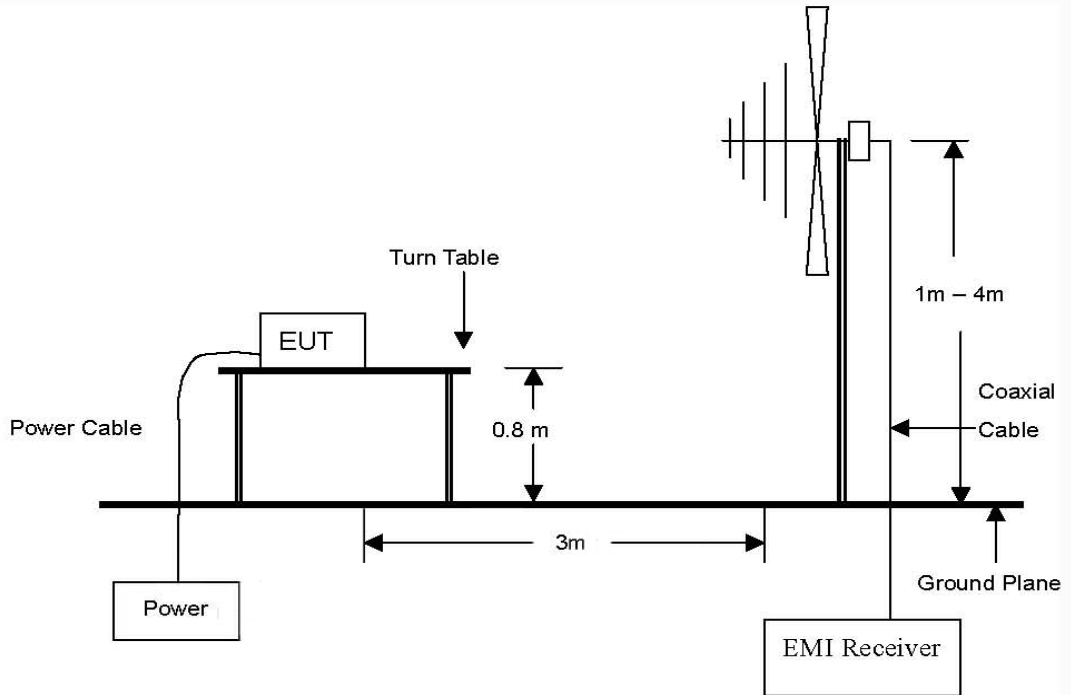

The diagram below shows the test setup that is utilized to make the measurements for emission. The spurious emissions were investigated from 1 GHz to the 10th harmonic of the highest fundamental frequency or 40 GHz, whichever is lower.

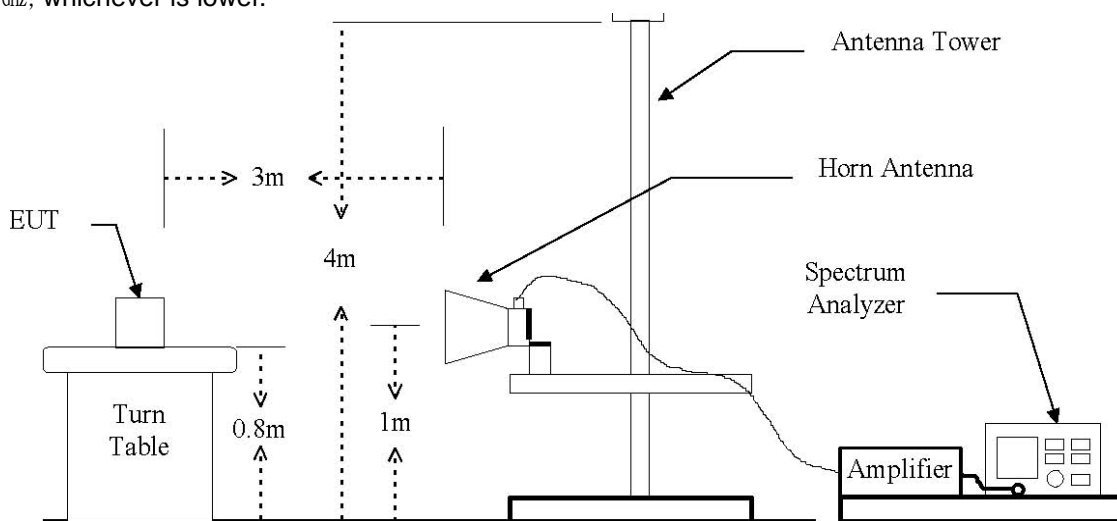

The results shown in this test report refer only to the sample(s) tested unless otherwise stated. This test report cannot be reproduced, except in full, without prior written permission of the Company.

2.1.2. Conducted Spurious Emission

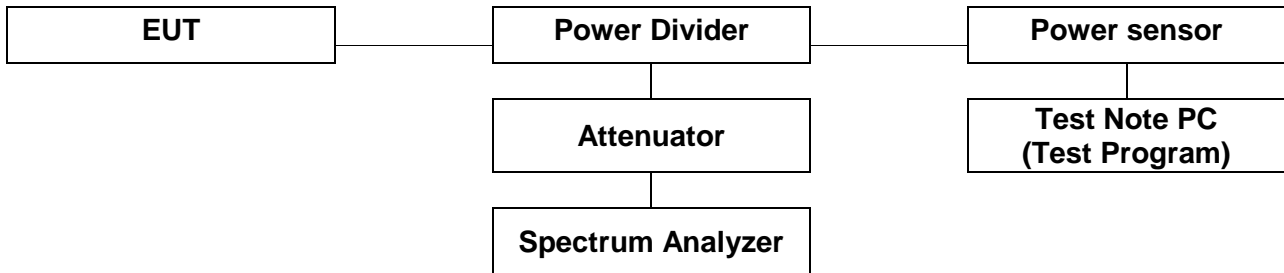

2.2. Limit

According to §15.247(d), in any 100 kHz bandwidth outside the frequency band in which the spread spectrum or digitally modulated intentional radiator is operating, the radio frequency power that is produced by the intentional radiator shall be at least 20 dB below that in the 100 kHz bandwidth within the band that contains the highest level of the desired power, based on either an RF conducted or a radiated measurement, provided the transmitter demonstrates compliance with the peak conducted power limits. If the transmitter complies with the conducted power limits based on the use of RMS averaging over a time interval, as permitted under paragraph(b)(3) of this section, the attenuation required under this paragraph shall be 30 dB instead of 20 dB. Attenuation below the general limits specified in section §15.209(a) is not required. In addition, radiated emission which in the restricted band, as define in section §15.205(a), must also comply the radiated emission limits specified in section §15.209(a) (see section §15.205(c))

According to § 15.209(a), Except as provided elsewhere in this Subpart, the emissions from an intentional radiator shall not exceed the field strength levels specified in the following table :

Frequency (MHz)	Distance (Meters)	Field Strength (dB μ V/m)	Field Strength (μ V/m)
30 - 88	3	40.0	100
88 – 216	3	43.5	150
216 – 960	3	46.0	200
Above 960	3	54.0	500

The results shown in this test report refer only to the sample(s) tested unless otherwise stated. This test report cannot be reproduced, except in full, without prior written permission of the Company.

2.3. Test Procedures

Radiated emissions from the EUT were measured according to the dictates in section 5.4 of KDB 558074

2.3.1. Test Procedures for Radiated Spurious Emissions

1. The EUT was placed on the top of a rotating table 0.8 meters above the ground at a 3 meter anechoic chamber test site. The table was rotated 360 degrees to determine the position of the highest radiation.
2. During performing radiated emission below 1 GHz, the EUT was set 3 meters away from the interference receiving antenna, which was mounted on the top of a variable-height antenna tower. During performing radiated emission above 1 GHz, the EUT was set 3 meter away from the interference-receiving antenna.
3. The antenna is a broadband antenna, and its height is varied from one meter to four meters above the ground to determine the maximum value of the field strength. Both horizontal and vertical polarizations of the antenna are set to make the measurement.
4. For each suspected emission, the EUT was arranged to its worst case and then the antenna was tuned to heights from 1 meter to 4 meters and the table was turned from 0 degrees to 360 degrees to find the maximum reading.
5. The test-receiver system was set to Peak Detect Function and Specified Bandwidth with Maximum Hold Mode.
6. If the emission level of the EUT in peak mode was 10 dB lower than the limit specified, then testing could be stopped and the peak values of the EUT would be reported. Otherwise the emissions that did not have 10 dB margin would be re-tested one by one using peak, quasi-peak or average method as specified and then reported in a data sheet.

NOTE ;

All data rates and modes were investigated for radiated spurious emissions. Only the radiated emissions of the configuration that produced the worst case emissions are reported in this section.

1. The measurements for below 1 GHz
Set the RBW = 100 - 120 kHz and VBW $\geq 3 \times$ RBW of test receiver/spectrum analyzer for Peak detection (PK) or Quasi-peak detection (QP)
2. The measurements for above 1 GHz
Average measurements are recorded using the RBAVG1 measurement procedure of KDB 558074.
Peak measurements are recorded using RBW = 1 MHz, VBW = 3 MHz
3. To get a maximum emission level from the EUT, the EUT is manipulated through three orthogonal planes.

2.3.2. Test Procedures for Conducted Spurious Emissions

All data rates and modes were investigated for conducted spurious emissions. Only the conducted emissions of the configuration that produced the worst case emissions are reported in this section.

Per the guidance of KDB 558074, section 5.4.1.1, the reference level for out of band emissions is established from the plots of this section since the band edge emissions are measured with a RBW of 100 kHz. This reference level is then used as the limit in subsequent plots for out of band spurious emissions shown in section 2.4.3. The limit for out of band spurious emission at the band edge is 30 dB below the fundamental emission level measured in a 100 kHz bandwidth.

The results shown in this test report refer only to the sample(s) tested unless otherwise stated. This test report cannot be reproduced, except in full, without prior written permission of the Company.

2.4. Test Results

Ambient temperature : (24 ± 2) °C
 Relative humidity : 47 % R.H.

2.4.1. Radiated Spurious Emission (Worst case configuration_11g mode, 6 Mbps, Low channel)

The frequency spectrum from 30 MHz to 1 000 MHz was investigated. All reading values are peak values.

Radiated Emissions			Ant	Correction Factors		Total	FCC Limit	
Frequency (MHz)	Reading (dBμV)	Detect Mode	Pol.	AF (dB/m)	AMP + CL (dB)	Actual (dBμV/m)	Limit (dBμV/m)	Margin (dB)
36.99	35.5	Peak	H	13.0	-26.6	21.9	40.0	18.1
386.07	37.2	Peak	V	13.6	-25.3	25.5	46.0	20.5
421.44	36.9	Peak	H	14.2	-25.2	25.9	46.0	20.1
537.27	39.9	Peak	V	16.6	-25.5	31.0	46.0	15.0
Above 600.00	Not detected	-	-	-	-	-	-	-

Remark:

- All spurious emission at channels are almost the same below 1 GHz, so that the middle channel was chosen at representative in final test.
- Actual = Reading + AF + AMP + CL

The results shown in this test report refer only to the sample(s) tested unless otherwise stated. This test report cannot be reproduced, except in full, without prior written permission of the Company.

2.4.2. Spurious Radiated Emission

The frequency spectrum above 1 000 MHz was investigated. Emission levels are not reported much lower than the limits by over 30 dB.

DSSS : 802.11b(1 Mbps)

Low Channel (2 412 MHz)

Radiated Emissions			Ant	Correction Factors		Total	FCC Limit	
Frequency (MHz)	Reading (dB μ V)	Detect Mode	Pol.	AF (dB/m)	CL (dB)	Actual (dB μ V/m)	Limit (dB μ V/m)	Margin (dB)
*2 390.00	25.39	Peak	H	28.05	5.23	58.67	74.00	15.33
*2 390.00	15.03	Average	H	28.05	5.23	48.31	54.00	5.69

Radiated Emissions			Ant	Correction Factors		Total	FCC Limit	
Frequency (MHz)	Reading (dB μ V)	Detect Mode	Pol.	AF (dB/m)	AMP+CL (dB)	Actual (dB μ V/m)	Limit (dB μ V/m)	Margin (dB)
*4 824.01	49.51	Peak	H	32.31	-34.55	47.27	74.00	26.73
*4 824.01	47.37	Average	H	32.31	-34.55	45.13	54.00	8.87
Above 4 900.00	Not detected	-	-	-	-	-	-	-

The results shown in this test report refer only to the sample(s) tested unless otherwise stated. This test report cannot be reproduced, except in full, without prior written permission of the Company.

Middle Channel (2 437 MHz)

Radiated Emissions			Ant	Correction Factors		Total	FCC Limit	
Frequency (MHz)	Reading (dB μ V)	Detect Mode	Pol.	AF (dB/m)	AMP+CL (dB)	Actual (dB μ V/m)	Limit (dB μ V/m)	Margin (dB)
*4 874.14	49.10	Peak	H	32.79	-34.53	47.36	74.00	26.64
*4 874.14	46.93	Average	H	32.79	-34.53	45.19	54.00	8.81
Above 4 900.00	Not detected	-	-	-	-	-	-	-

High Channel (2 462 MHz)

Radiated Emissions			Ant	Correction Factors		Total	FCC Limit	
Frequency (MHz)	Reading (dB μ V)	Detect Mode	Pol.	AF (dB/m)	CL (dB)	Actual (dB μ V/m)	Limit (dB μ V/m)	Margin (dB)
*2 483.50	24.66	Peak	H	28.31	5.37	58.34	74.00	15.66
*2 483.50	15.49	Average	H	28.31	5.37	49.17	54.00	4.83

Radiated Emissions			Ant	Correction Factors		Total	FCC Limit	
Frequency (MHz)	Reading (dB μ V)	Detect Mode	Pol.	AF (dB/m)	AMP+CL (dB)	Actual (dB μ V/m)	Limit (dB μ V/m)	Margin (dB)
*4 924.08	49.11	Peak	H	33.10	-34.24	47.97	74.00	26.03
*4 924.08	46.78	Average	H	33.10	-34.24	45.64	54.00	8.36
Above 5 000.00	Not detected	-	-	-	-	-	-	-

The results shown in this test report refer only to the sample(s) tested unless otherwise stated. This test report cannot be reproduced, except in full, without prior written permission of the Company.

DSSS : 802.11g(6 Mbps)

Low Channel (2 412 MHz)

Radiated Emissions			Ant	Correction Factors		Total	FCC Limit	
Frequency (MHz)	Reading (dB μ V)	Detect Mode	Pol.	AF (dB/m)	CL (dB)	Actual (dB μ V/m)	Limit (dB μ V/m)	Margin (dB)
*2 390.00	27.07	Peak	H	28.05	5.23	60.35	74.00	13.65
*2 390.00	16.44	Average	H	28.05	5.23	49.72	54.00	4.28

Radiated Emissions			Ant	Correction Factors		Total	FCC Limit	
Frequency (MHz)	Reading (dB μ V)	Detect Mode	Pol.	AF (dB/m)	AMP+CL (dB)	Actual (dB μ V/m)	Limit (dB μ V/m)	Margin (dB)
*4 833.14	42.66	Peak	H	32.43	-34.60	40.49	74.00	33.51
*4 833.14	30.27	Average	H	32.43	-34.60	28.10	54.00	25.90
Above 4 900.00	Not detected	-	-	-	-	-	-	-

Middle Channel (2 437 MHz)

Radiated Emissions			Ant	Correction Factors		Total	FCC Limit	
Frequency (MHz)	Reading (dB μ V)	Detect Mode	Pol.	AF (dB/m)	AMP+CL (dB)	Actual (dB μ V/m)	Limit (dB μ V/m)	Margin (dB)
*4 877.65	42.92	Peak	H	32.82	-34.51	41.23	74.00	32.77
*4 877.65	30.75	Average	H	32.82	-34.51	29.06	54.00	24.94
Above 4 900.00	Not detected	-	-	-	-	-	-	-

The results shown in this test report refer only to the sample(s) tested unless otherwise stated. This test report cannot be reproduced, except in full, without prior written permission of the Company.

High Channel (2 462 MHz)

Radiated Emissions			Ant	Correction Factors		Total	FCC Limit	
Frequency (MHz)	Reading (dB μ V)	Detect Mode	Pol.	AF (dB/m)	CL (dB)	Actual (dB μ V/m)	Limit (dB μ V/m)	Margin (dB)
*2 483.50	25.97	Peak	H	28.31	5.37	59.65	74.00	14.35
*2 483.50	16.45	Average	H	28.31	5.37	50.13	54.00	3.87

Radiated Emissions			Ant	Correction Factors		Total	FCC Limit	
Frequency (MHz)	Reading (dB μ V)	Detect Mode	Pol.	AF (dB/m)	AMP+CL (dB)	Actual (dB μ V/m)	Limit (dB μ V/m)	Margin (dB)
*4 913.57	42.24	Peak	H	33.04	-34.28	41.00	74.00	33.00
*4 913.57	30.28	Average	H	33.04	-34.28	29.04	54.00	24.96
Above 5 000.00	Not detected	-	-	-	-	-	-	-

Remarks :

1. "*" means the restricted band.
2. Radiated emissions measured in frequency above 1 000 MHz were made with an instrument using peak/average detector mode.
3. Average test would be performed if the peak result were greater than the average limit.
4. Actual = Reading + AF + AMP + CL

The results shown in this test report refer only to the sample(s) tested unless otherwise stated. This test report cannot be reproduced, except in full, without prior written permission of the Company.

2.4.3. Spurious RF Conducted Emissions: Plot of Spurious RF Conducted Emission

DSSS : 802.11b(1 Mbps)

Low Channel

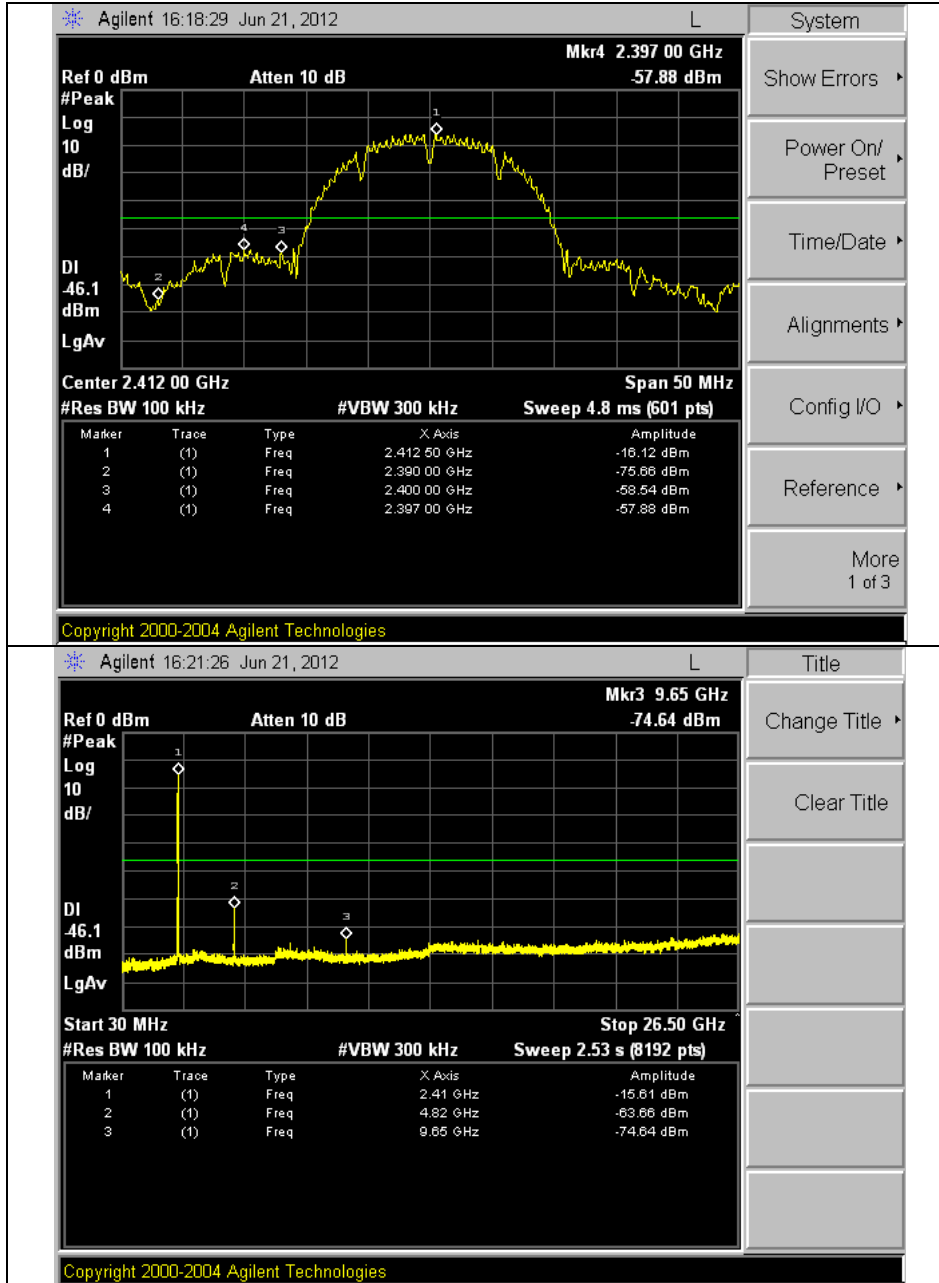

Note:

Offset (dB) = Power Divider (dB) + Attenuator (dB) + Cable loss (dB)

Result (dB m) = Spurious offset (dB) + Reading values (dB m)

Frequency (MHz)	Spurious offset (dB)	Reading values (dB m)	Result (dB m)
2 390.00	20.97	-75.66	-54.69
2 397.00	20.96	-57.88	-36.92
2 400.00	20.96	-58.54	-37.58
4 820.00	21.64	-63.66	-42.02
9 650.00	22.73	-74.64	-51.91

The results shown in this test report refer only to the sample(s) tested unless otherwise stated. This test report cannot be reproduced, except in full, without prior written permission of the Company.

Middle Channel

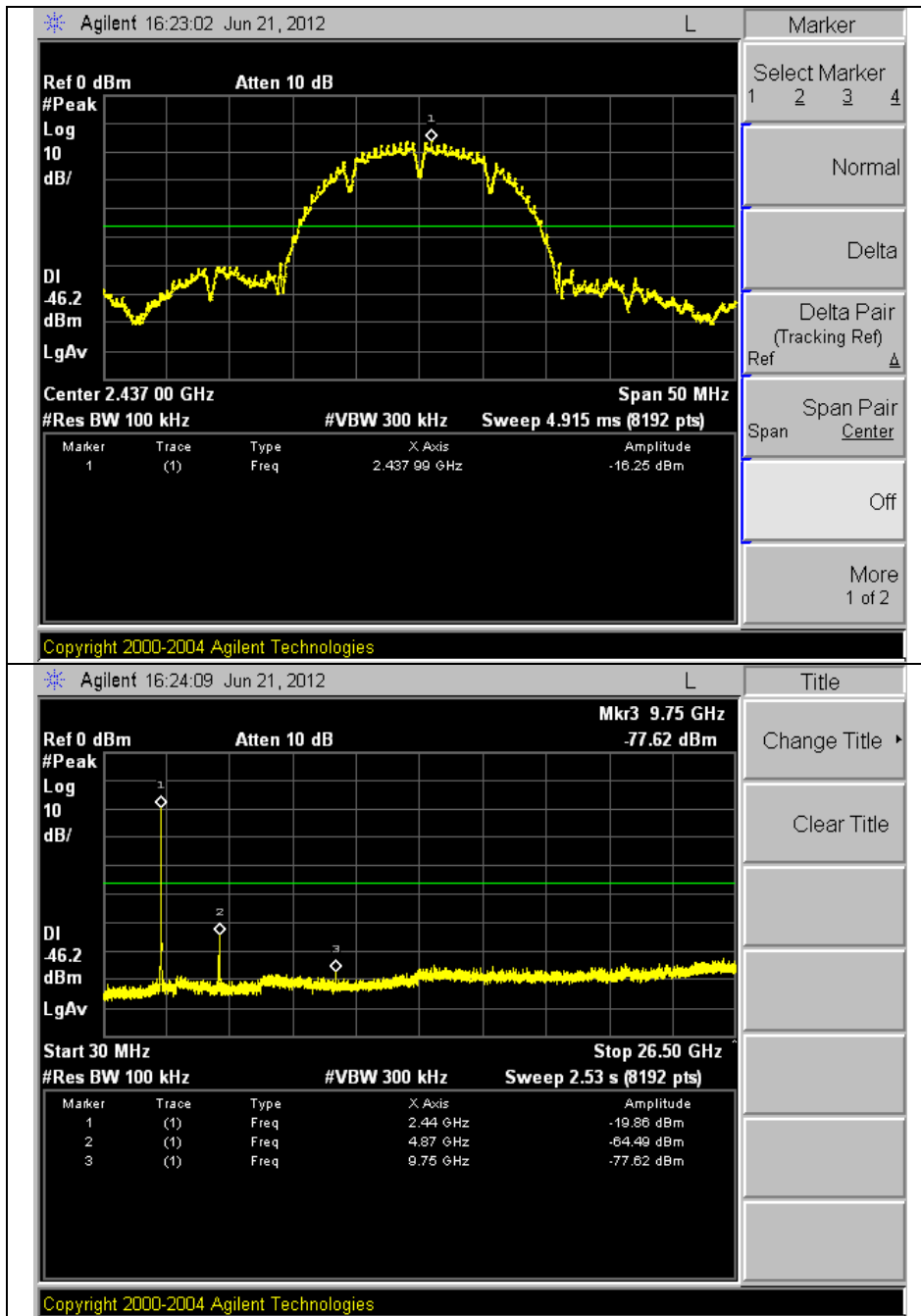

Note:

Offset (dB) = Power Divider (dB) + Attenuator(dB) + Cable loss (dB)

Result (dB m) = Spurious offset (dB) + Reading values (dB m)

Frequency (MHz)	Spurious offset (dB)	Reading values (dB m)	Result (dB m)
4 870.00	21.64	-64.49	-42.85
9 750.00	22.73	-77.62	-54.89

The results shown in this test report refer only to the sample(s) tested unless otherwise stated. This test report cannot be reproduced, except in full, without prior written permission of the Company.

High Channel

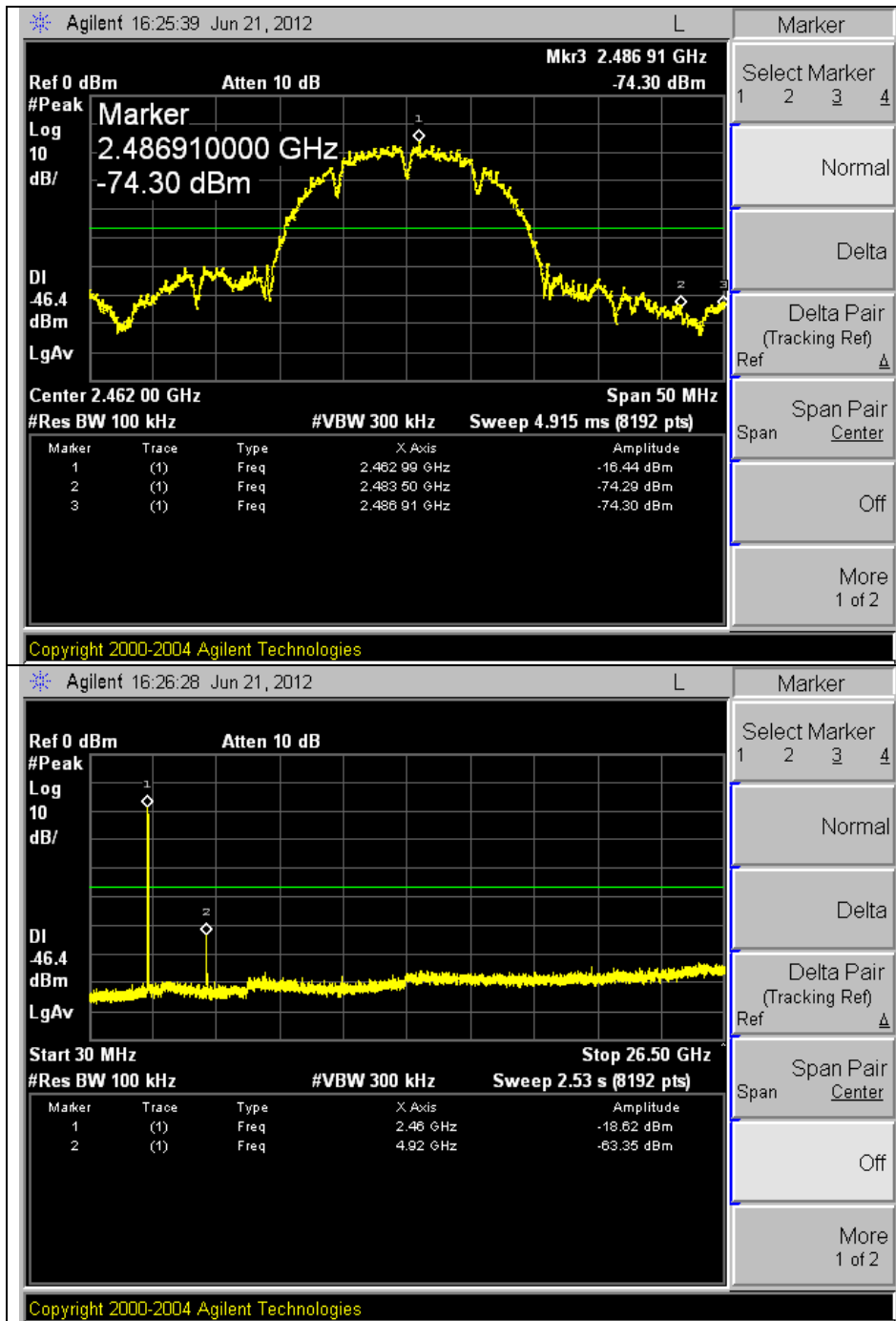

Note:

Offset (dB) = Power Divider (dB) + Attenuator (dB) + Cable loss (dB)

Result (dB m) = Spurious offset (dB) + Reading values (dB m)

Frequency (MHz)	Spurious offset (dB)	Reading values (dB m)	Result (dB m)
2 483.50	20.98	-74.29	-53.31
2 486.91	20.98	-74.30	-53.32
4 920.00	21.64	-63.35	-41.71

The results shown in this test report refer only to the sample(s) tested unless otherwise stated. This test report cannot be reproduced, except in full, without prior written permission of the Company.

OFDM : 802.11g(6 Mbps)

Low Channel

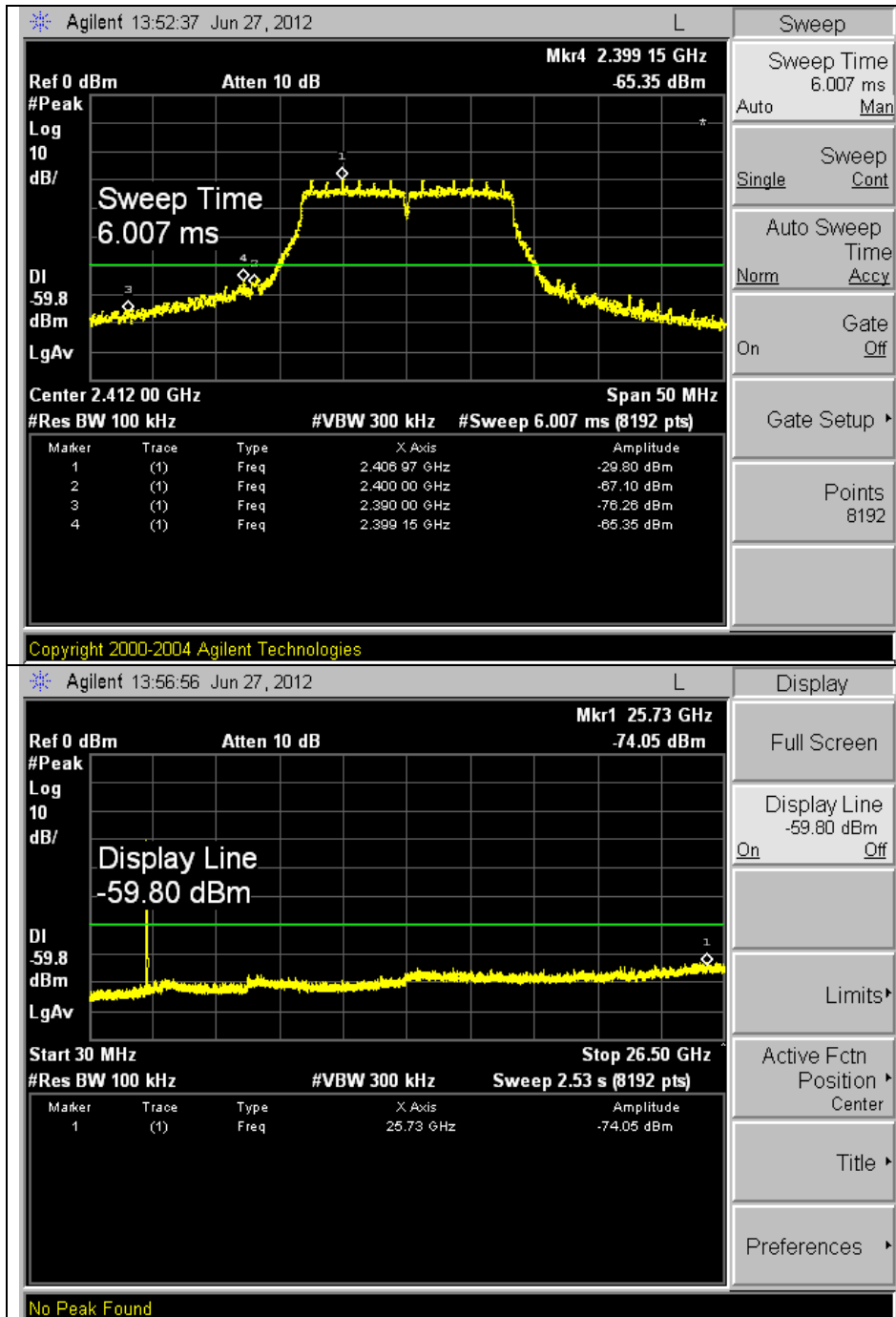

Note:

Offset (dB) = Power Divider (dB) + Attenuator(dB) + Cable loss (dB)

Result (dB m) = Spurious offset (dB) + Reading values (dB m)

Frequency (MHz)	Spurious offset (dB)	Reading values (dB m)	Result (dB m)
2 390.00	28.27	-76.26	-47.99
2 399.15	28.31	-65.35	-37.04
2 400.00	28.31	-67.10	-38.79
25 730.00	38.51	Noise floor	-

The results shown in this test report refer only to the sample(s) tested unless otherwise stated. This test report cannot be reproduced, except in full, without prior written permission of the Company.

Middle Channel

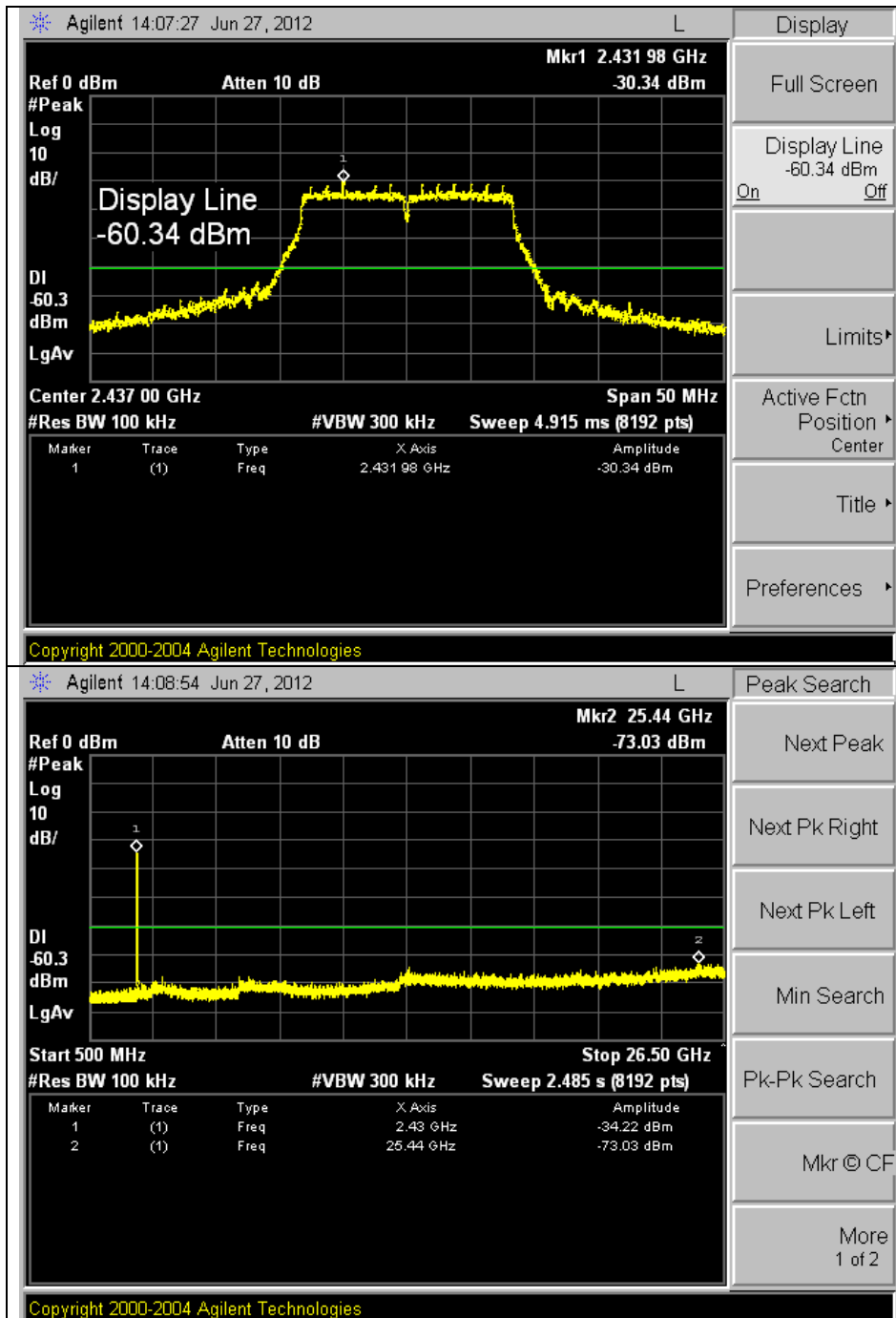

Note:

Offset (dB) = Power Divider (dB) + Attenuator(dB) + Cable loss (dB)

Result (dB m) = Spurious offset (dB) + Reading values (dB m)

Frequency (MHz)	Spurious offset (dB)	Reading values (dB m)	Result (dB m)
25 440.00	36.34	Noise floor	-

The results shown in this test report refer only to the sample(s) tested unless otherwise stated. This test report cannot be reproduced, except in full, without prior written permission of the Company.

High Channel

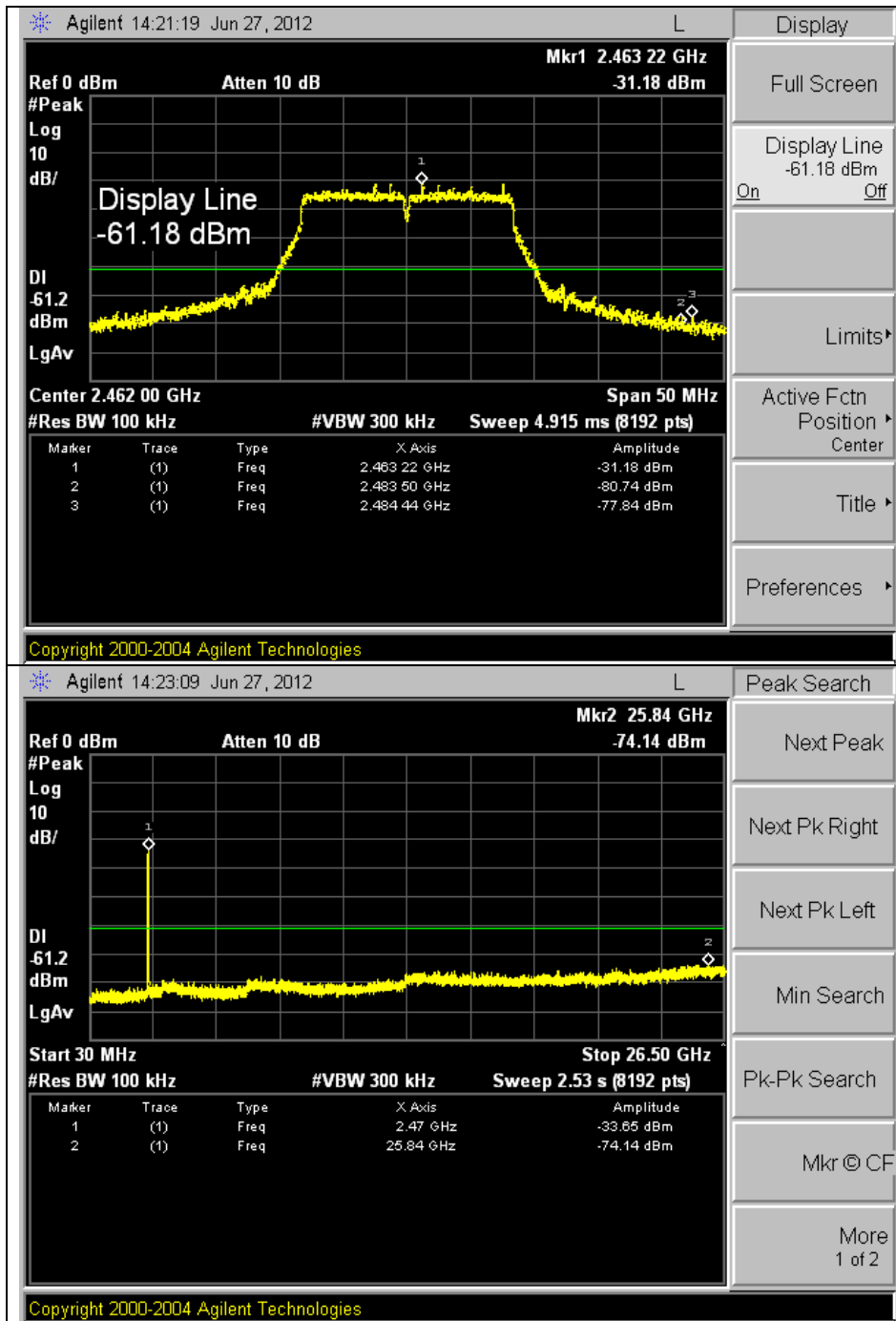

Note:

Offset (dB) = Power Divider (dB) + Attenuator (dB) + Cable loss (dB)

Result (dB m) = Spurious offset (dB) + Reading values (dB m)

Frequency (MHz)	Spurious offset (dB)	Reading values (dB m)	Result (dB m)
2 483.50	28.32	-80.74	-52.42
2 484.44	28.32	-77.84	-49.52
25 840.00	39.81	Noise floor	-

The results shown in this test report refer only to the sample(s) tested unless otherwise stated. This test report cannot be reproduced, except in full, without prior written permission of the Company.

3. 6 dB Bandwidth Measurement

3.1. Test Setup

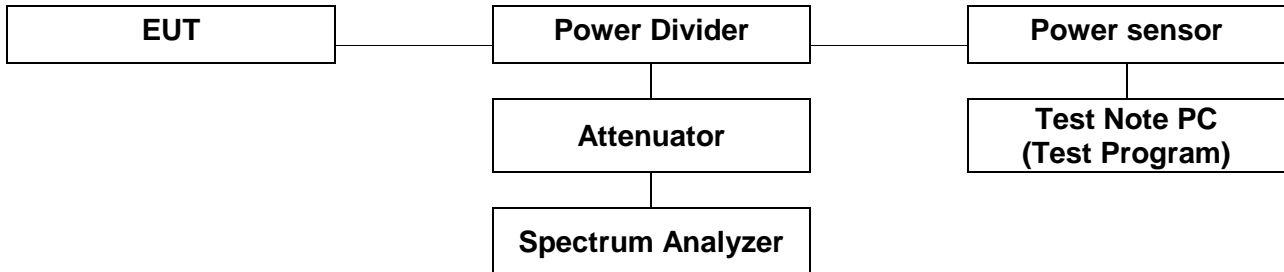

3.2. Limit

According to §15.247(a)(2), systems using digital modulation techniques may operate in the 902 ~928 MHz, 2 400 ~ 2 483.5 MHz, and 5 725 ~ 5 825 MHz bands. The minimum of 6 dB Bandwidth shall be at least 500 kHz

3.3. Test Procedure

All data rates and modes were investigated for this test. The full data for the worst case data rate are reported in this section.

The test follows section 5.1 of FCC KDB Publication 558074

1. Set resolution bandwidth (RBW) = 1 – 5 % of the emission bandwidth (EBW).
2. Set the video bandwidth (VBW) $\geq 3 \times$ RBW.
3. Detector = Peak.
4. Trace mode = max hold.
5. Sweep = auto couple.
6. Allow the trace to stabilize.
7. Measure the maximum width of the emission that is constrained by the frequencies associated with the two outermost amplitude point (upper and lower) that are attenuated by 6 dB relative to the maximum level measured in the fundamental emission. Compare the resultant bandwidth with the RBW setting of the analyzer. Readjust RBW and repeat measurement as needed until the RBW/EBW ratio is 1 – 5 %.

The results shown in this test report refer only to the sample(s) tested unless otherwise stated. This test report cannot be reproduced, except in full, without prior written permission of the Company.

3.4. Test Results

Ambient temperature : (24 ± 2) °C
 Relative humidity : 47 % R.H.

Operation Mode	Data Rate (Mbps)	Channel	Channel Frequency (MHz)	6 dB Bandwidth (MHz)	Minimum Limit (MHz)
DSSS (802.11b)	1	Low	2 412	10.33	0.5
		Middle	2 437	10.33	
		High	2 462	10.33	
OFDM (802.11g)	6	Low	2 412	16.50	0.5
		Middle	2 437	16.58	
		High	2 462	16.58	

The results shown in this test report refer only to the sample(s) tested unless otherwise stated. This test report cannot be reproduced, except in full, without prior written permission of the Company.

6 dB Bandwidth

DSSS : 802.11b

Low Channel

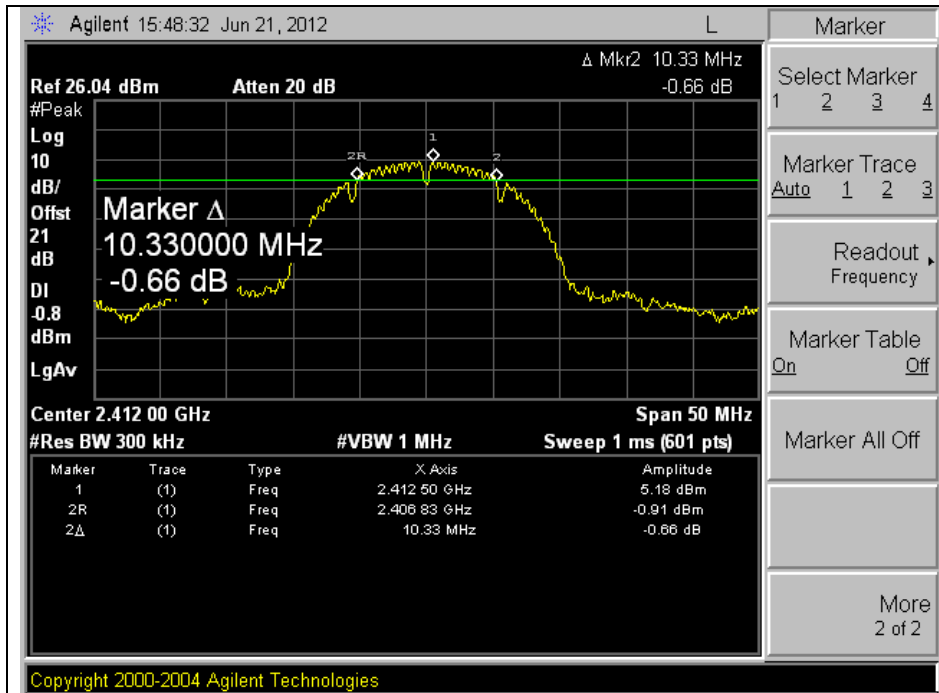

Middle Channel

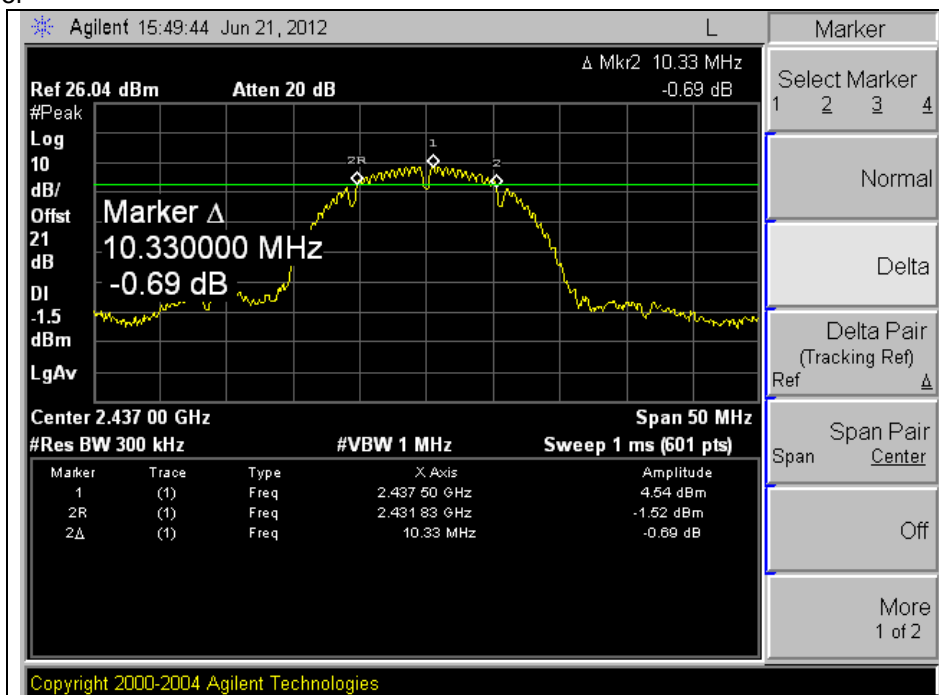

The results shown in this test report refer only to the sample(s) tested unless otherwise stated. This test report cannot be reproduced, except in full, without prior written permission of the Company.

High Channel

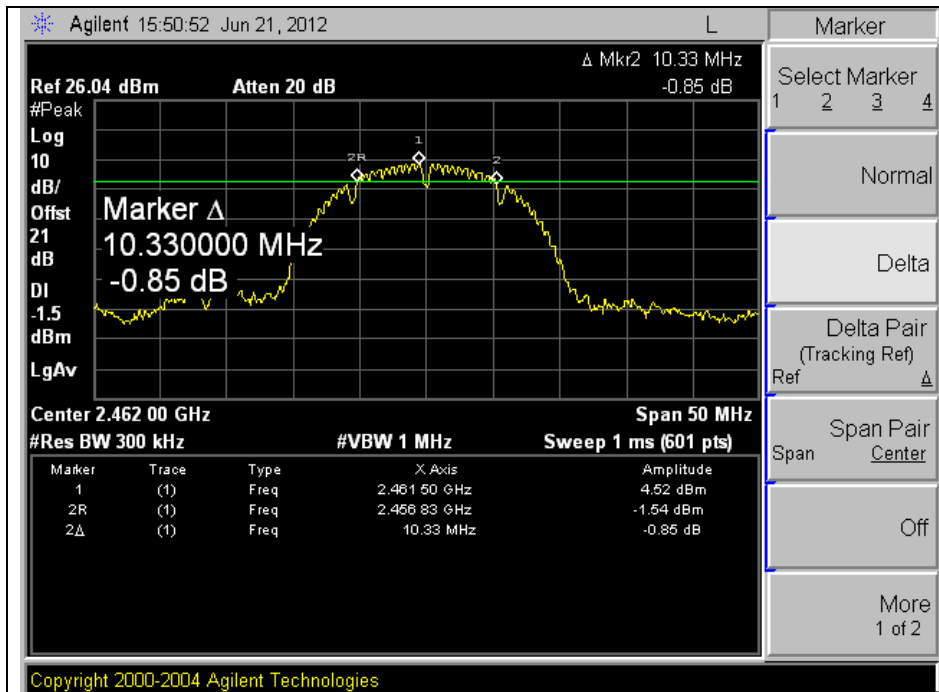

OFDM : 802.11g

Low Channel

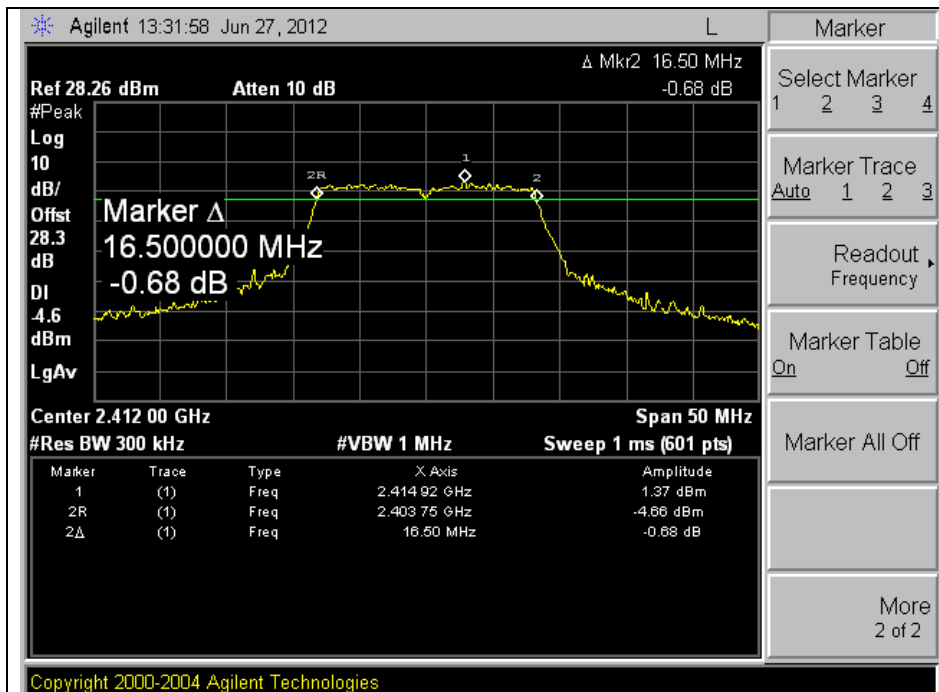

The results shown in this test report refer only to the sample(s) tested unless otherwise stated. This test report cannot be reproduced, except in full, without prior written permission of the Company.

Middle Channel

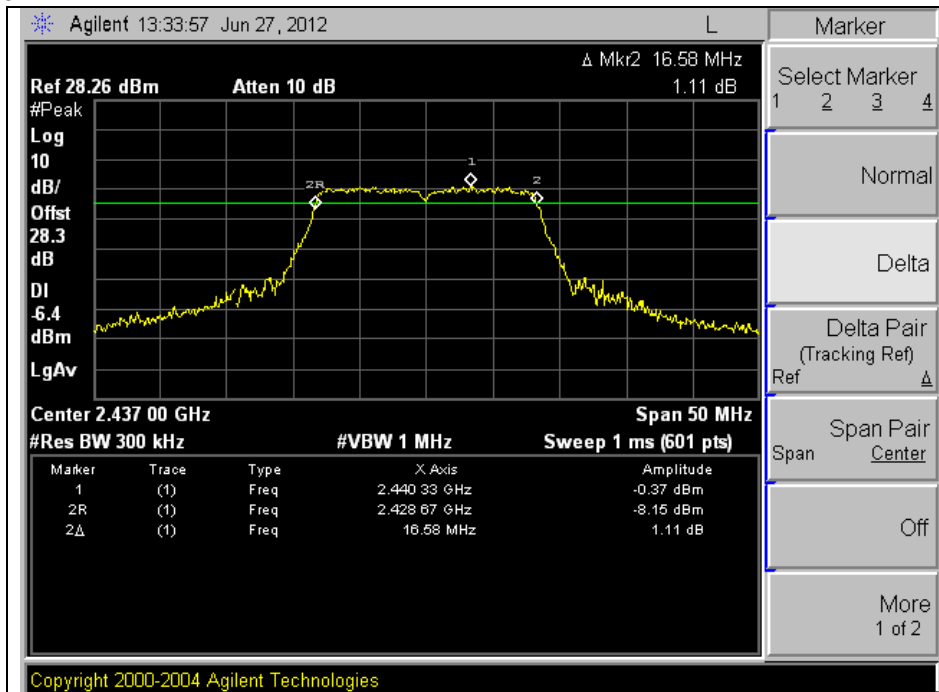

High Channel

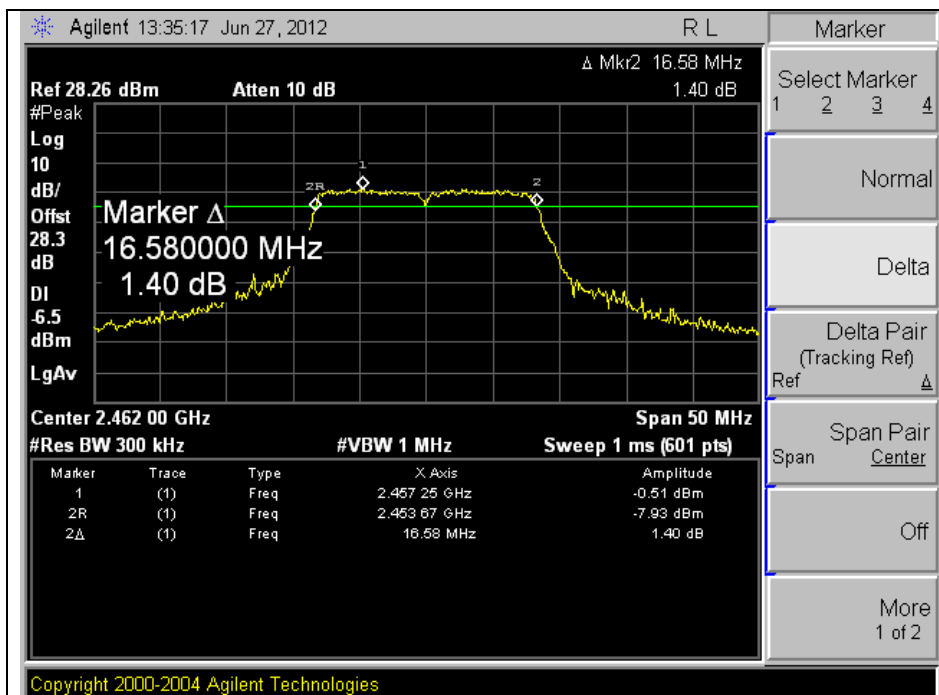

The results shown in this test report refer only to the sample(s) tested unless otherwise stated. This test report cannot be reproduced, except in full, without prior written permission of the Company.

4. Maximum Peak Output Power Measurement

4.1. Test Setup

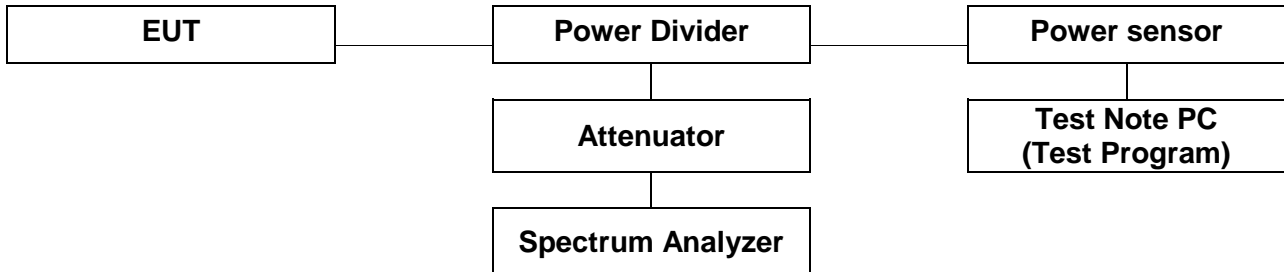

4.2. Limit

According to §15.247(b)(3), for systems using digital modulation in the 902 ~ 928 MHz, 2 400 ~2 483.5 MHz, and 5 725 ~ 5 850 MHz band: 1 Watt. As an alternative to a peak power measurement, compliance with the one watt limit can be based on a measurement of the maximum conducted output power. Maximum Conducted output Power is defined as the total transmit power delivered to all antennas and antenna elements averaged across all symbols in the signaling alphabet when the transmitter is operating at its maximum power control level. Power must be summed across all antenna elements. The average must not include any intervals during which the transmitter is off or is transmitting at a reduced power level. If multiple modes of operation are possible (e.g., alternative modulation methods), the maximum conducted output power is the highest total transmit power occurring in any mode.

According to §15.247(b)(4), the conducted output power limit specified in paragraph(b) of this section is based on the use of antenna with directional gains that do not exceed 6 dBi. Except as shown in paragraph(c) of this section, if transmitting antenna of directional gain greater than 6 dBi are used, the conducted output power from the intentional radiator shall be reduced below the stated values in paragraph (b)(1), (b)(2), and (b)(3) of this section, as appropriate, by the amount in dB that the directional gain of the antenna exceeds 6dBi.

4.3. Test Procedure

- 11b, g

1. Place the EUT on the table and set it in the transmitting mode.
2. Remove the antenna from the EUT and then connect a low loss RF cable from the antenna port to the Power sensor.
3. Test program : (S/W name : R&S Power Viewer, Version : 3.2.0)
4. Measure peak & average power each channel.

The results shown in this test report refer only to the sample(s) tested unless otherwise stated. This test report cannot be reproduced, except in full, without prior written permission of the Company.

4.4. Test Results

Ambient temperature : (24 ± 2) °C
 Relative humidity : 47 % R.H.

Mode	Channel	Channel Frequency (MHz)	Data Rate (Mbps)	Attenuator + Cable offset (dB)	Average power Result (dB m)	Peak Power Result (dB m)
DSSS (802.11b)	Low	2 412	1	26.67	13.53	16.06
			2		13.31	15.94
			5.5		13.02	16.01
			11		12.45	16.02
	Middle	2 437	1	26.79	12.87	15.48
			2		12.81	15.43
			5.5		12.60	15.50
			11		12.26	15.60
	High	2 462	1	26.99	13.27	15.75
			2		13.13	15.73
			5.5		12.67	15.65
			11		12.34	15.88
OFDM (802.11g)	Low	2 412	6	26.67	8.36	17.73
			9		8.14	17.77
			12		7.80	17.76
			18		7.28	17.85
			24		6.75	18.45
			36		5.94	18.59
			48		5.40	18.22
			54		5.08	18.73
	Middle	2 437	6	26.79	7.70	17.47
			9		7.37	17.35
			12		7.11	17.36
			18		6.63	17.60
			24		6.12	17.22
			36		5.22	18.20
			48		4.73	17.82
			54		4.38	18.36
	High	2 462	6	26.99	7.95	17.33
			9		7.67	17.38
			12		7.55	17.59
			18		7.00	17.47
			24		6.56	18.17
			36		5.58	18.29
			48		5.05	18.02
			54		4.65	18.50

The results shown in this test report refer only to the sample(s) tested unless otherwise stated. This test report cannot be reproduced, except in full, without prior written permission of the Company.

5. Power Spectral Density Measurement

5.1. Test Setup

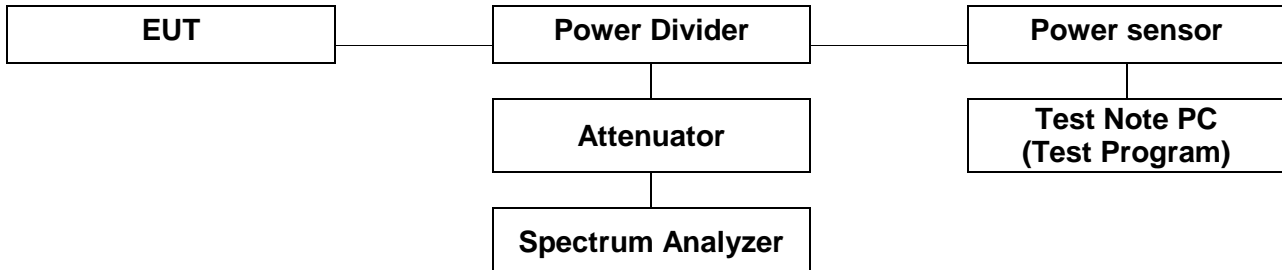

5.2. Limit

§15.247(e) For digitally modulated system, the power spectral density conducted from the intentional radiator to the antenna shall not be greater than 8 dB m in any 3 kHz band any time interval of continuous transmission. This power spectral density shall be determined in accordance with the provisions of paragraph (b) of this section. The same method of determining the conducted output power shall be used to determine the power spectral density.

5.3. Test Procedure

All data rates and modes were investigated for this test. The full data for the worst case data rate are reported in this section.

The measurements are recorded using the AVGPSD measurement procedure in section 5.3 of KDB 558074.

1. Use this procedure when the maximum conducted output power in the fundamental emission is used to demonstrate compliance. The EUT must be configured to transmit continuously at full power over the measurement duration.
2. Set the analyzer span to 5 – 30 % greater than the EBW.
3. Set the RBW = 100 kHz
4. Set the VBW \geq 300 kHz
5. Detector = power average (RMS).
6. Ensure that the number of measurement points in the sweep $\geq 2 \times$ span/RBW (use of a greater number of measurement points than this minimum requirement is recommended).
7. Manually set the sweep time to : $\geq 10 \times$ (number of measurement points in sweep) \times (transmission symbol period).
8. Perform the measurement over a single sweep.
9. Use the peak marker function to determine the maximum level in any 100 kHz band segment within the fundamental EBW.
10. Scale the observed power level to an equivalent level in 3 kHz by adjusting (reducing) the measured power by a bandwidth correction factor (BWCF) where : $BWCF = 10\log(3 \text{ kHz}/100 \text{ kHz} = -15.2 \text{ dB})$.
11. The resulting PSD level must be $\leq 8 \text{ dB m}$.

The results shown in this test report refer only to the sample(s) tested unless otherwise stated. This test report cannot be reproduced, except in full, without prior written permission of the Company.

5.4. Test Results

Ambient temperature : (24 ± 2) °C
 Relative humidity : 47 % R.H.

Operation Mode	Data Rate (Mbps)	Channel	Frequency	Measured PSD (dB m)	Bandwidth Correction Factor (dB)	Corrected PSD (dB m)	Maximum Limit (dB m)
DSSS (802.11b)	1	Low	2 412 MHz	-2.72	-15.20	-17.92	8
		Middle	2 437 MHz	-3.51	-15.20	-18.71	8
		High	2 462 MHz	-3.40	-15.20	-18.60	8
OFDM (802.11g)	6	Low	2 412 MHz	-10.56	-15.20	-25.76	8
		Middle	2 437 MHz	-11.71	-15.20	-26.91	8
		High	2 462 MHz	-11.25	-15.20	-26.45	8

Note;

Corrected Power Spectral Density (dB m) = Measured Power Spectral Density (dB m) + Bandwidth Correction Factor (dB)

The results shown in this test report refer only to the sample(s) tested unless otherwise stated. This test report cannot be reproduced, except in full, without prior written permission of the Company.

DSSS : 802.11b

Low Channel

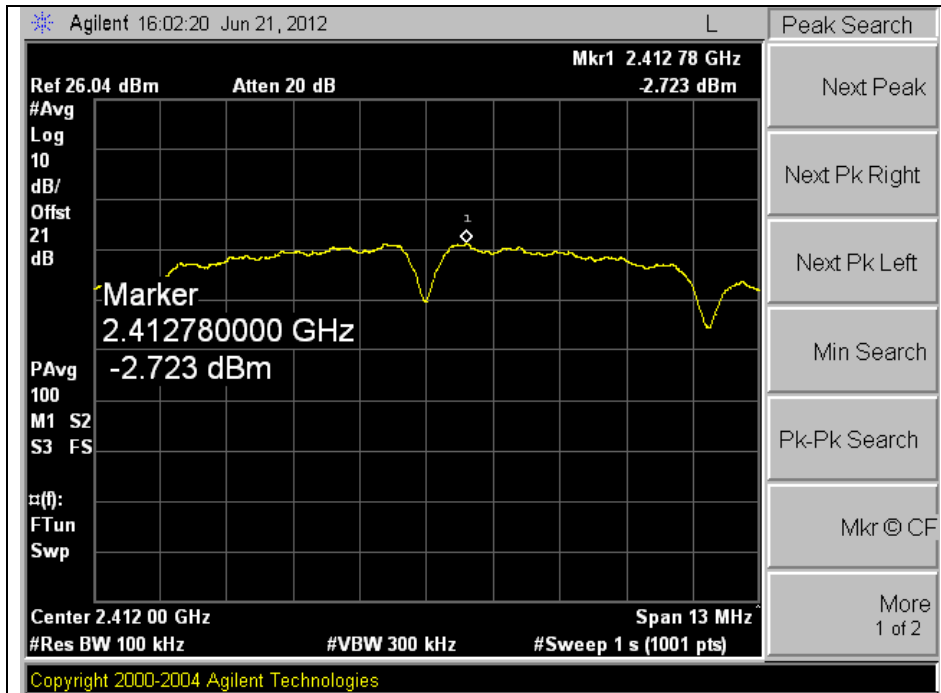

Middle Channel

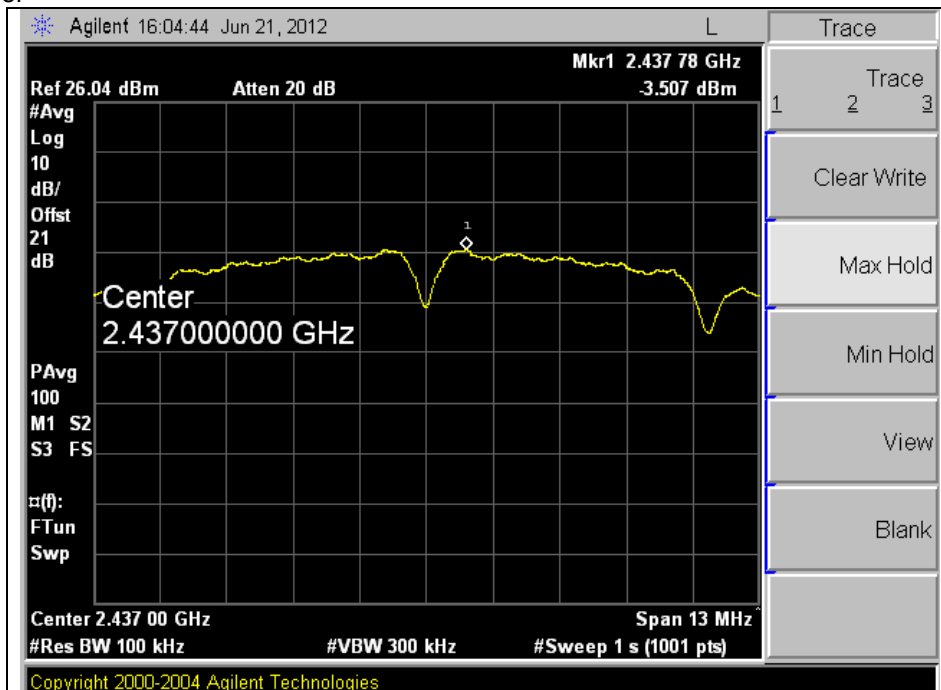

The results shown in this test report refer only to the sample(s) tested unless otherwise stated. This test report cannot be reproduced, except in full, without prior written permission of the Company.

High Channel

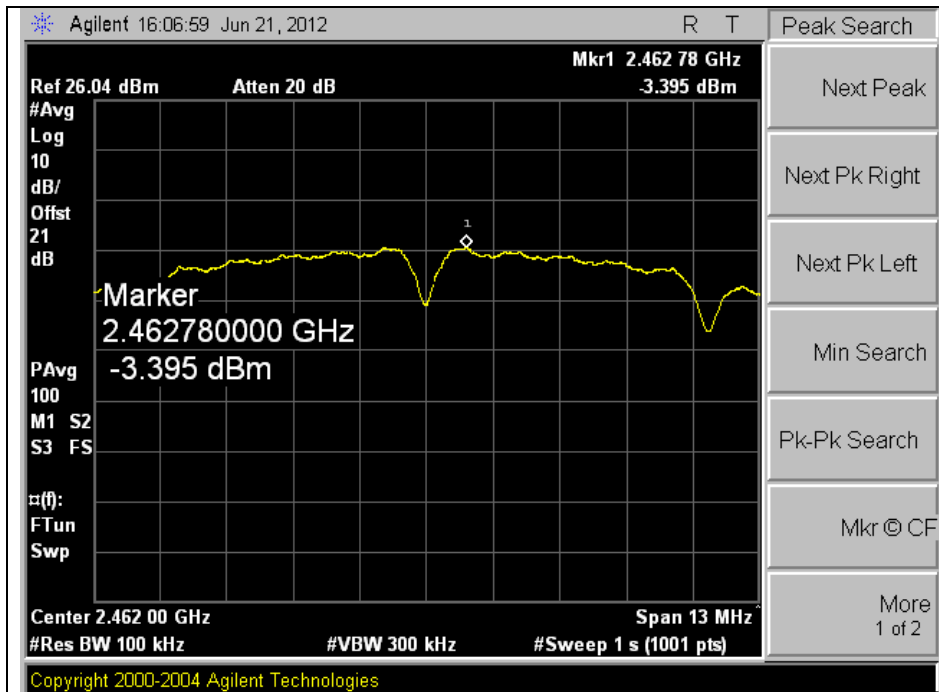

OFDM : 802.11g

Low Channel

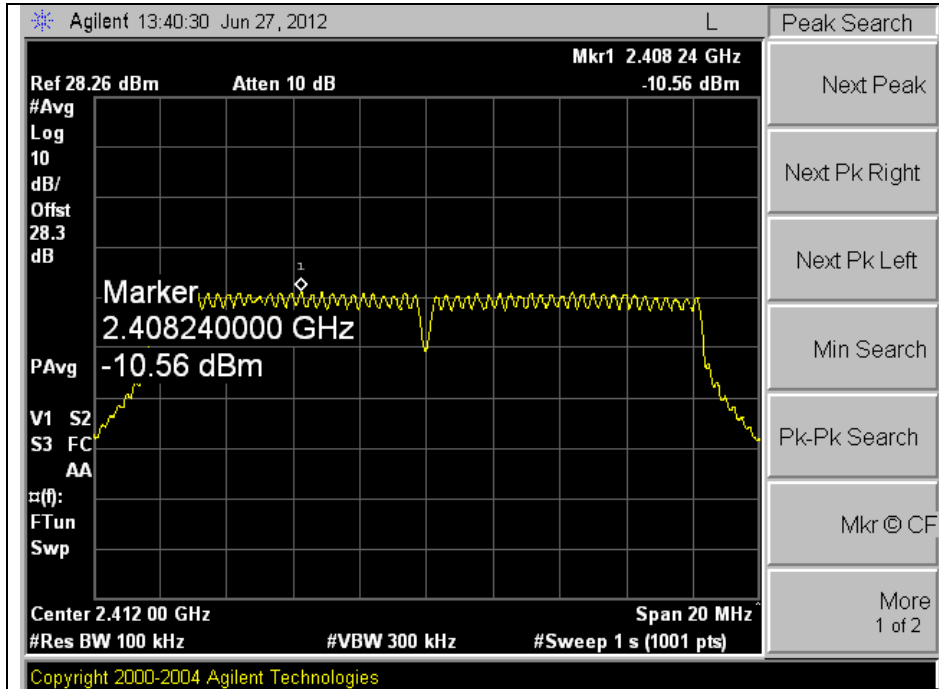

The results shown in this test report refer only to the sample(s) tested unless otherwise stated. This test report cannot be reproduced, except in full, without prior written permission of the Company.

Middle Channel

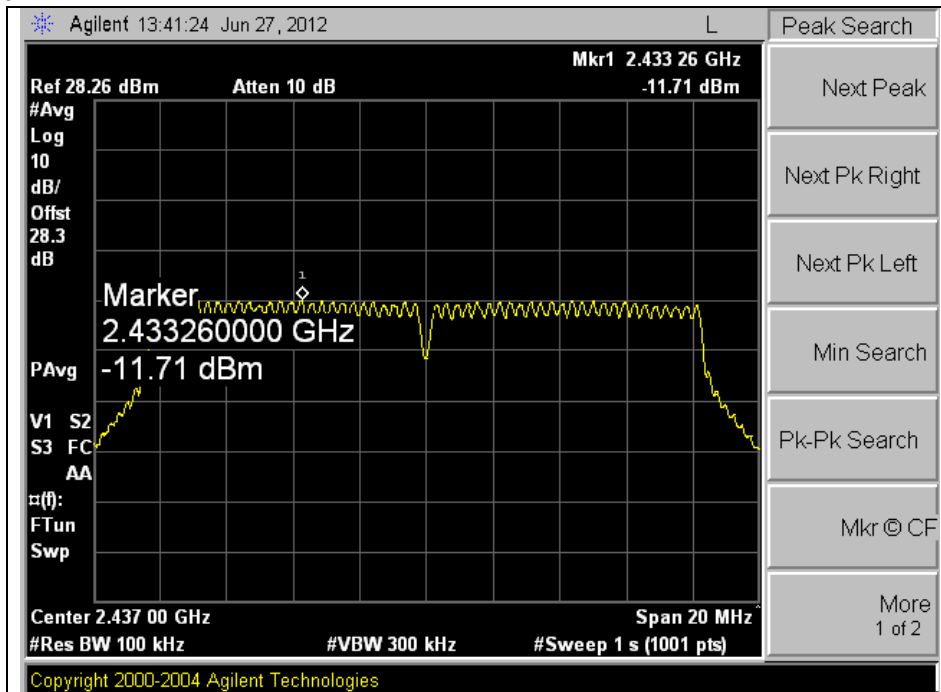

High Channel

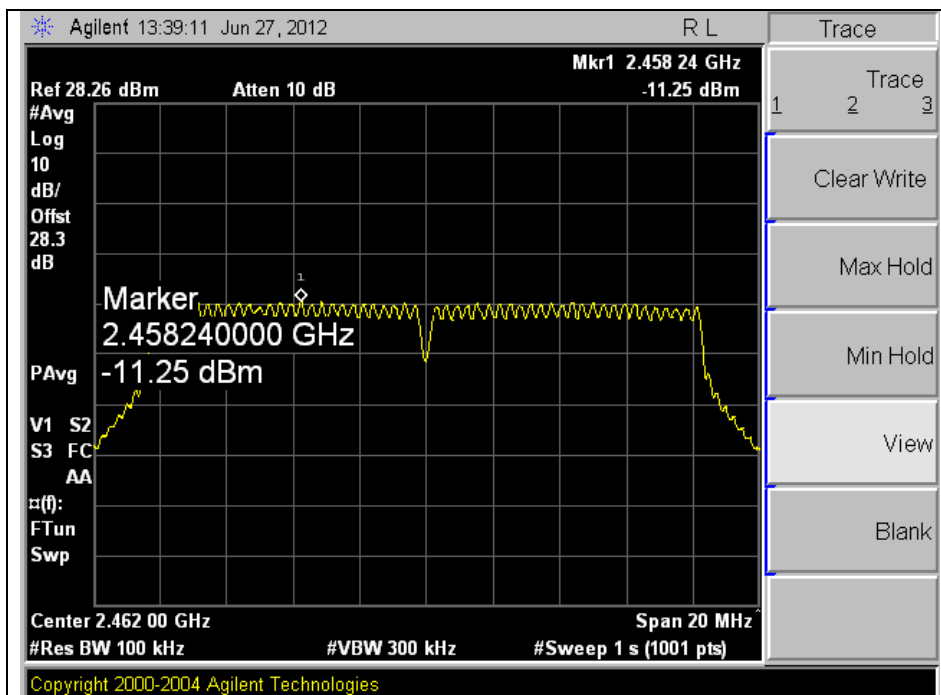

The results shown in this test report refer only to the sample(s) tested unless otherwise stated. This test report cannot be reproduced, except in full, without prior written permission of the Company.

6. Transmitter AC Power Line Conducted Emission

6.1. Test Setup

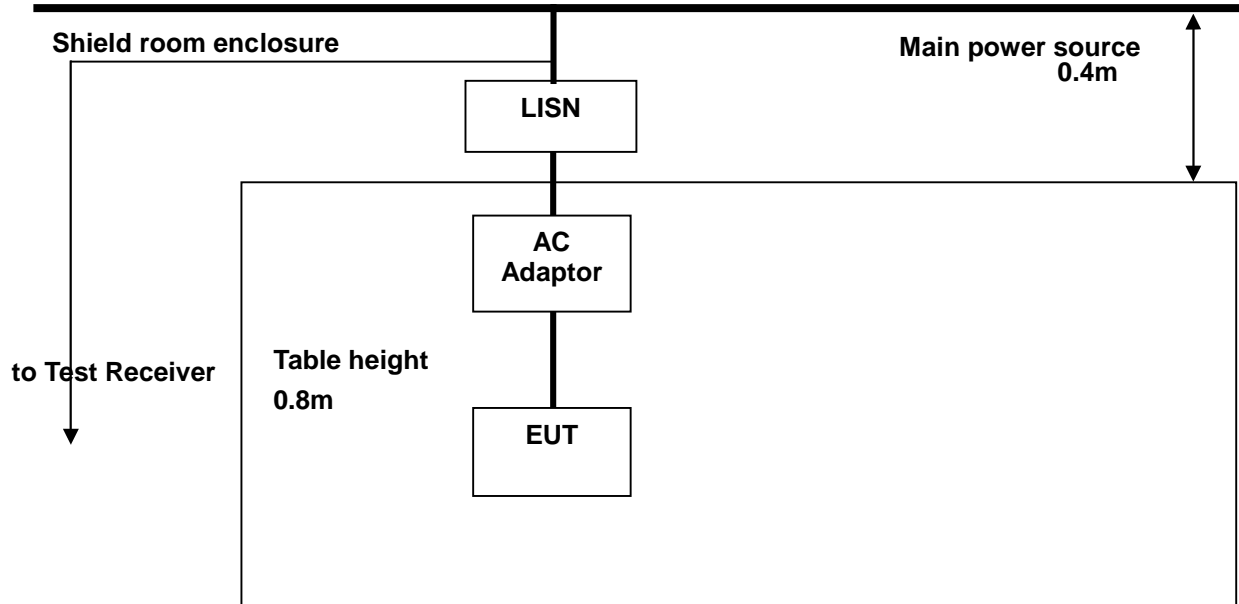

6.2. Limit

According to §15.207(a) for an intentional radiator that is designed to be connected to the public utility (AC) power line, the radio frequency voltage that is conducted back onto the AC power line on any frequency or frequencies, within the band 150 kHz to 30 MHz, shall not exceed the limits in the following table, as measured using a 50 uH/50 ohm line impedance stabilization network(LISN).

Compliance with the provision of this paragraph shall on the measurement of the radio frequency voltage between each power line and ground at the power terminal. The lower applies at the boundary between the frequency ranges.

Frequency of Emission (MHz)	Conducted limit (dB μ V)	
	Quasi-peak	Average
0.15 – 0.50	66 - 56*	56 - 46*
0.50 – 5.00	56	46
5.00 – 30.0	60	50

* Decreases with the logarithm of the frequency.

The results shown in this test report refer only to the sample(s) tested unless otherwise stated. This test report cannot be reproduced, except in full, without prior written permission of the Company.

6.3. Test Procedures

All data rates and modes were investigated for this test. The full data for the worst case data rate are reported in this section.

AC line conducted emissions from the EUT were measured according to the dictates of ANSI C63.4-2003

1. The test procedure is performed in a 6.5m × 3.6m × 3.6m (L × W × H) shielded room. The EUT along with its peripherals were placed on a 1.0 m(W) × 1.5 m(L) and 0.8 m in height wooden table and the EUT was adjusted to maintain a 0.4 meter space from a vertical reference plane.
2. The EUT was connected to power mains through a line impedance stabilization network (LISN) which provides 50 ohm coupling impedance for measuring instrument and the chassis ground was bounded to the horizontal ground plane of shielded room.
3. The excess power cable between the EUT and the LISN was bundled. All connecting cables of EUT were moved to find the maximum emission.

The results shown in this test report refer only to the sample(s) tested unless otherwise stated. This test report cannot be reproduced, except in full, without prior written permission of the Company.

6.4. Test Results (Worst case configuration_11b mode, 1 Mbps, Low channel)

The following table shows the highest levels of conducted emissions on both phase of Hot and Neutral line.

Ambient temperature : (24 ± 2) °C
 Relative humidity : 47 % R.H.

Frequency range : 0.15 MHz – 30 MHz
 Measured Bandwidth : 9 kHz

FREQ. (MHz)	LEVEL(dB μ V)		LINE	LIMIT(dB μ V)		MARGIN(dB)	
	Q-Peak	Average		Q-Peak	Average	Q-Peak	Average
0.17	35.13	24.83	H	64.96	54.96	29.83	30.13
0.25	39.33	30.83	H	61.76	51.76	22.43	20.93
0.54	36.54	25.04	H	56.00	46.00	19.46	20.96
1.12	36.17	25.67	H	56.00	46.00	19.83	20.33
1.74	35.79	23.99	H	56.00	46.00	20.21	22.01
2.09	35.30	24.30	H	56.00	46.00	20.70	21.70
0.17	34.71	22.41	N	65.21	55.21	30.50	32.80
0.26	36.21	28.91	N	61.59	51.59	25.38	22.68
0.64	30.82	21.32	N	56.00	46.00	25.18	24.68
1.06	33.75	25.15	N	56.00	46.00	22.25	20.85
1.22	34.06	24.56	N	56.00	46.00	21.94	21.44
1.26	34.16	24.96	N	56.00	46.00	21.84	21.04

Note ;

Line (H) : Hot

Line (N) : Neutral

The results shown in this test report refer only to the sample(s) tested unless otherwise stated. This test report cannot be reproduced, except in full, without prior written permission of the Company.

Plots of Conducted Power line

Test mode : (Hot)

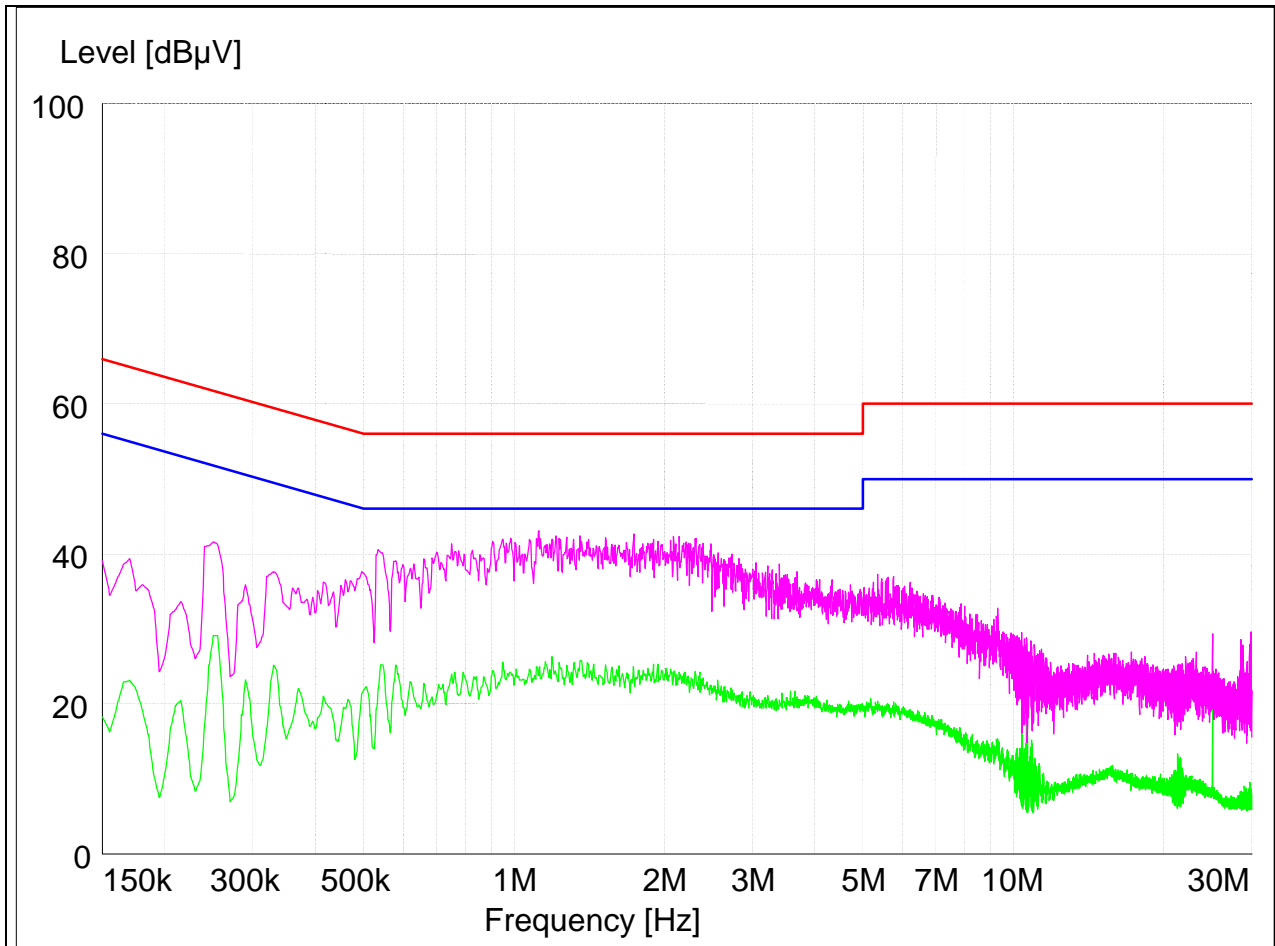

The results shown in this test report refer only to the sample(s) tested unless otherwise stated. This test report cannot be reproduced, except in full, without prior written permission of the Company.

Test mode : (Neutral)

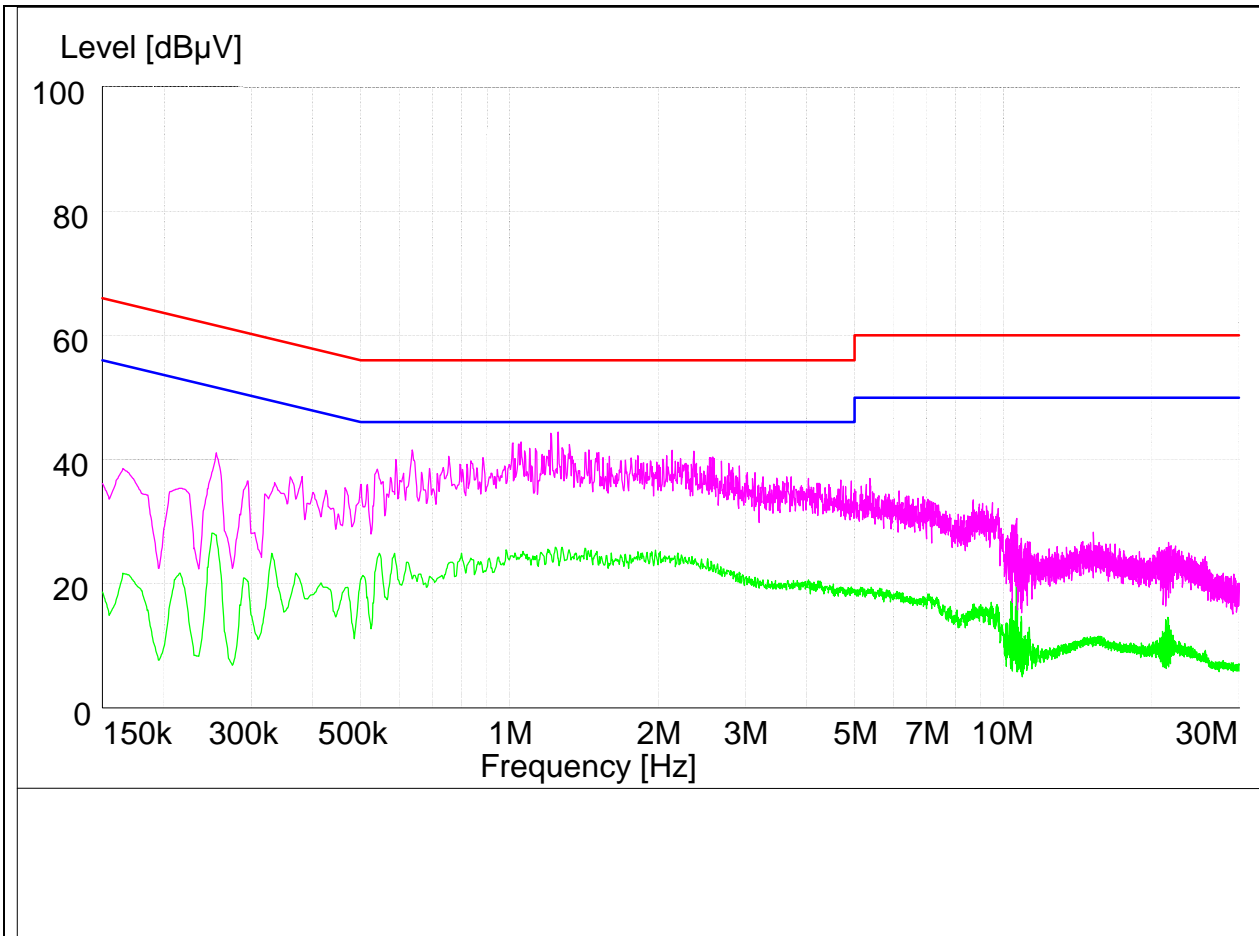

The results shown in this test report refer only to the sample(s) tested unless otherwise stated. This test report cannot be reproduced, except in full, without prior written permission of the Company.

7. Antenna Requirement

7.1. Standard Applicable

For intentional device, according to FCC 47 CFR Section §15.203, an intentional radiator shall be designed to ensure that no antenna other than that furnished by the responsible party shall be used with the device. And according to FCC 47 CFR Section §15.247 (b) if transmitting antennas of directional gain greater than 6 dB i are used, the power shall be reduced by the amount in dB that the gain of the antenna exceeds 6 dB i.

7.2. Antenna Connected Construction

Antenna used in this product is Internal type with gain of -0.75 dB i.