

This drawing is property of SEC. Use or copy of this drawing without proper permission from the appropriate technical-document managing department is prohibited.

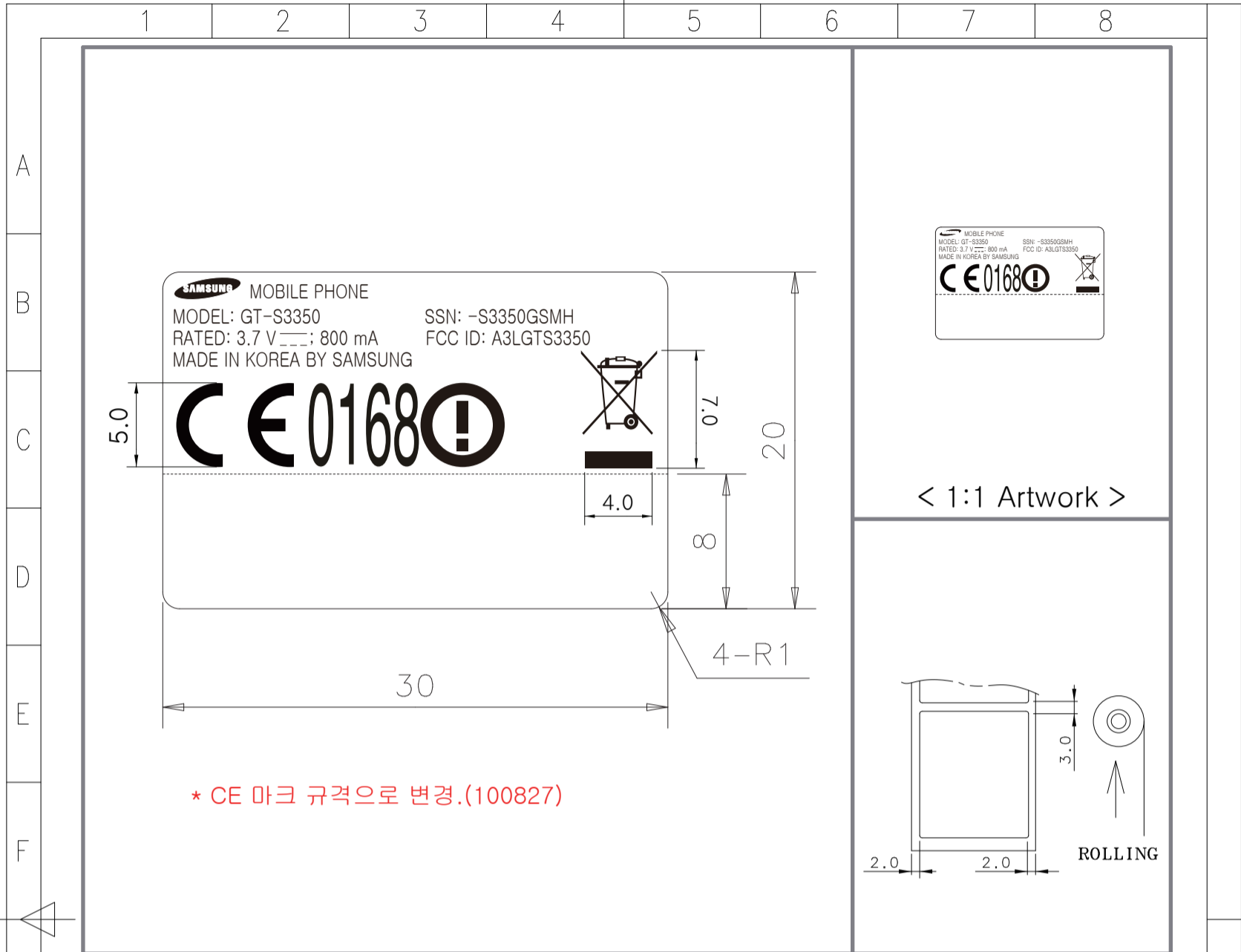

Technical Description

1. Use 'AI / PDF' provided by 'SAMSUNG' for letter and contents
2. Background color is 'WHITE', letter color is 'BLACK'
(reverse for SAMSUNG LOGO)
3. Back side should be attached to release paper once adhesive is applied.
4. No letter should be blur/smeared
5. The production must be proceed after the approval of SAMSUNG R&D Group
6. The product must be within approved sample's specification tolerance.
7. The product must be finished in a ROLL
8. Release paper must be unifiedn for material and color(blue)
9. Do not contain any substances which are specified in (OQA-2049).

MAT.		WHITE POLYESTER			FIN.		Semi transparency OPP Laminating + UVP Coating	
TITLE		GT-S3350(EU)						
		LABEL-MAIN						
UNIT	mm	DESIGNED	CHECKED	APPROVED	PROJECTION			
TOLERANCE	+0.0 -0.1	Park Tae San	Jo Kyeong Hwan	Kim June Sop				
SCALE	N/S					SHEET NO		1/1
Vendor	HANSUNG	100614	100614	100614				
SAMSUNG ELECTRONICS		Doc. CODE						

This drawing is property of SEC. Use or copy of this drawing without proper permission from the appropriate technical-document managing department is prohibited.

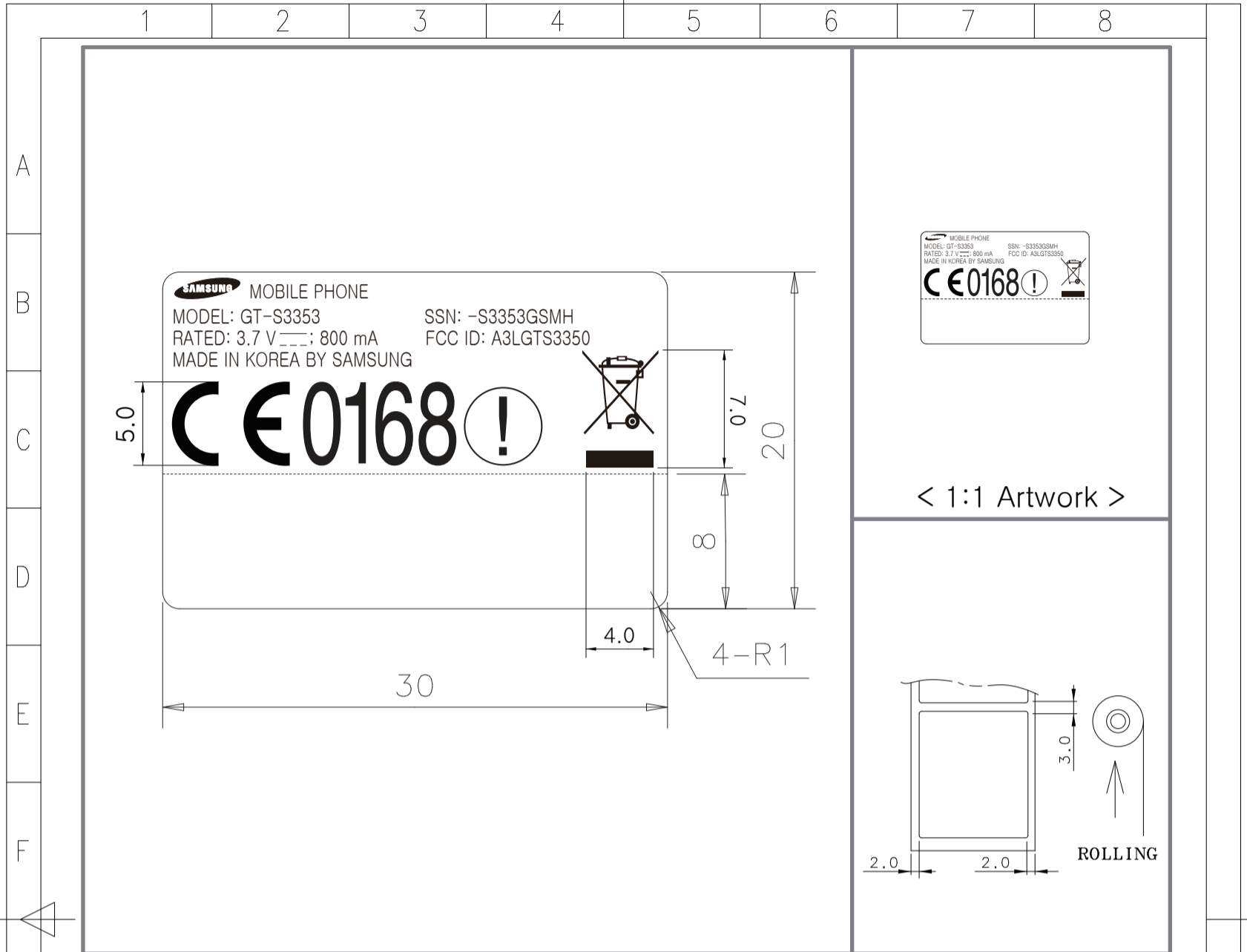

Technical Description

1. Use 'AI / PDF' provided by 'SAMSUNG' for letter and contents
2. Background color is 'WHITE', letter color is 'BLACK'
(reverse for SAMSUNG LOGO)
3. Back side should be attached to release paper once adhesive is applied.
4. No letter should be blur/smeared
5. The production must be proceed after the approval of SAMSUNG R&D Group
6. The product must be within approved sample's specification tolerance.
7. The product must be finished in a ROLL
8. Release paper must be unifiedn for material and color(blue)
9. Do not contain any substances which are specified in (OQA-2049).

MAT.		WHITE POLYESTER			FIN.		Semi transparency OPP Laminating + UVP Coating	
TITLE		GT-S3353(EU)						
		LABEL-MAIN						
UNIT	mm	DESIGNED	CHECKED	APPROVED	PROJECTION			
TOLERANCE	+0.0 -0.1	Park Tae San	Jo Kyeong Hwan	Kim June Sop				
SCALE	N/S					SHEET NO	1/1	
Vendor	HANSUNG	100810	100810	100810				
SAMSUNG ELECTRONICS		Doc. CODE						

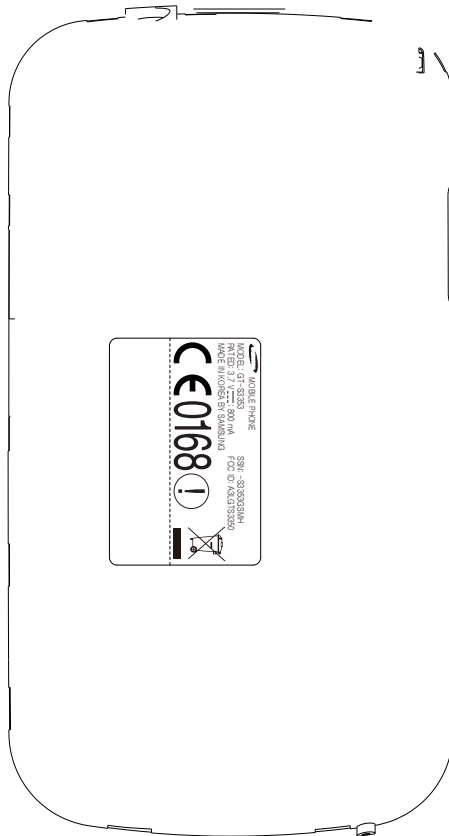

The label is placed inside the battery compartment

The FCC ID Label shown will be readily visible at the time of purchase.