

APPENDIX 2 : System Validation

1. Validation uncertainty

The uncertainty budget has been determined for the DASYS measurement system according to the SPEAG documents[2] and is given in the following Table.

<300MHz-6GHz>

Error Description	Uncertainty value \pm %	Probability distribution	divisor	(ci) 1g	Standard Uncertainty (1g)	vi or veff
Measurement System						
Probe calibration	± 6.55	Normal	1	1	± 6.55	∞
Axial isotropy of the probe	± 4.7	Rectangular	$\sqrt{3}$	1	± 2.7	∞
Spherical isotropy of the probe	± 9.6	Rectangular	0	0	0	∞
Boundary effects	± 1.0	Rectangular	$\sqrt{3}$	1	± 1.2	∞
Probe linearity	± 4.7	Rectangular	$\sqrt{3}$	1	± 2.7	∞
Detection limit	± 1.0	Rectangular	$\sqrt{3}$	1	± 0.6	∞
Readout electronics	± 0.3	Normal	1	1	± 0.3	∞
Response time	0	Rectangular	$\sqrt{3}$	1	0	∞
Integration time	0	Rectangular	$\sqrt{3}$	1	0	∞
RF ambient Noise	± 1.0	Rectangular	$\sqrt{3}$	1	± 1.7	∞
RF ambient Reflections	± 1.0	Rectangular	$\sqrt{3}$	1	± 1.7	∞
Probe Positioner	± 0.8	Rectangular	$\sqrt{3}$	1	± 0.5	∞
Probe positioning	± 6.7	Rectangular	$\sqrt{3}$	1	± 3.9	∞
Algorithms for Max.SAR Eval.	± 2.0	Rectangular	$\sqrt{3}$	1	± 1.2	∞
Dipole						
Deviation of exp.dipole	± 5.5	Rectangular	$\sqrt{3}$	1	± 3.2	∞
Dipole Axis to Liquid Distance	± 2.0	Rectangular	$\sqrt{3}$	1	± 1.2	∞
Input power and SAR drift meas.	± 3.4	Rectangular	$\sqrt{3}$	1	± 2.7	∞
Phantom and Setup						
Phantom uncertainty	± 4.0	Rectangular	$\sqrt{3}$	1	± 2.3	∞
SAR correction	± 1.9	Rectangular	$\sqrt{3}$	1	± 1.1	
Liquid conductivity (target)	± 5.0	Rectangular	$\sqrt{3}$	0.78	± 2.3	∞
Liquid conductivity (meas.)	± 5.0	Rectangular	1	0.26	± 1.3	∞
Liquid permittivity (target)	± 5.0	Rectangular	$\sqrt{3}$	0.78	± 2.3	∞
Liquid permittivity (meas.)	-4.9	Rectangular	1	0.23	± 1.1	∞
Combined Standard Uncertainty						
					± 11.00	
Expanded Uncertainty (k=2)						
					± 22.0	

2. System validation result 2450MHz

System validation result for Head 2450

Simulated Tissue Liquid Parameter confirmation

DIELECTRIC PARAMETERS MEASUREMENT RESULTS										
Date	Ambient Temp. [deg.c]	Relative Humidity [%]	Liquid type	Liquid Temp. [deg.c]	Measured Frequency [MHz]	Parameters	Target Value*1	Measured	Deviation [%]	Limit [%]
7-Oct	24	57	HSL 2450	23.5	2450	ϵ_r	39.2	38.0	-3.1	+/-5
						σ [mho/m]	1.80	1.89	5.0	+/-5

ϵ_r : Relative Permittivity / σ : Conductivity

*1 The Target value is a parameter defined in FCC OET 65.

System validation result

SYSTEM VALIDATION							
Date	Frequency [MHz]	SAR 1g [W/kg]					
		Forward Power 250mW		Conversion 1W	Target 1W *1	Deviation [%]	Limit [%]
		Measured	Calculation				
7-Oct	2450.00	13.20	52.80	52.40	0.8	+/-10	

*1 The target value is the parameter defined in IEEE 1528.

2450MHz System Validation DATA / Dipole2.4GHz / Forward Conducted Power : 250mW

Communication System: CW; Communication System Band: D2450 (2450.0 MHz); Frequency: 2450 MHz; Duty Cycle: 1:1

Medium parameters used: $f = 2450$ MHz; $\sigma = 1.89$ mho/m; $\epsilon_r = 38$; $\rho = 1000$ kg/m³

Phantom section: Flat Section

Measurement Standard: DASYS5 (IEEE/IEC/ANSI C63.19-2007)

DASY5 Configuration

Probe: EX3DV3 - SN3507; ConvF(7.88, 7.88, 7.88); Calibrated: 2011/03/16

Sensor-Surface: 2mm (Mechanical Surface Detection)

Electronics: DAE4 Sn509; Calibrated: 2011/07/20

Phantom: ELI 4.0; Type: QDOVA001BA;

Measurement SW: DASY52, Version 52.6 (1);

Area Scan (61x61x1): Measurement grid: $dx=15$ mm, $dy=15$ mm

Maximum value of SAR (interpolated) = 21.622 mW/g

Zoom Scan (7x7x7)/Cube 0: Measurement grid: $dx=5$ mm, $dy=5$ mm, $dz=5$ mm

Reference Value = 106.3 V/m; Power Drift = -0.08 dB

Peak SAR (extrapolated) = 27.595 W/kg

SAR(1 g) = 13.2 mW/g; SAR(10 g) = 6.09 mW/g

Maximum value of SAR (measured) = 20.223 mW/g

Date: 2011/10/07

Ambient Temp. : 24.0 degree.C. Liquid Temp.; 23.5 degree.C.

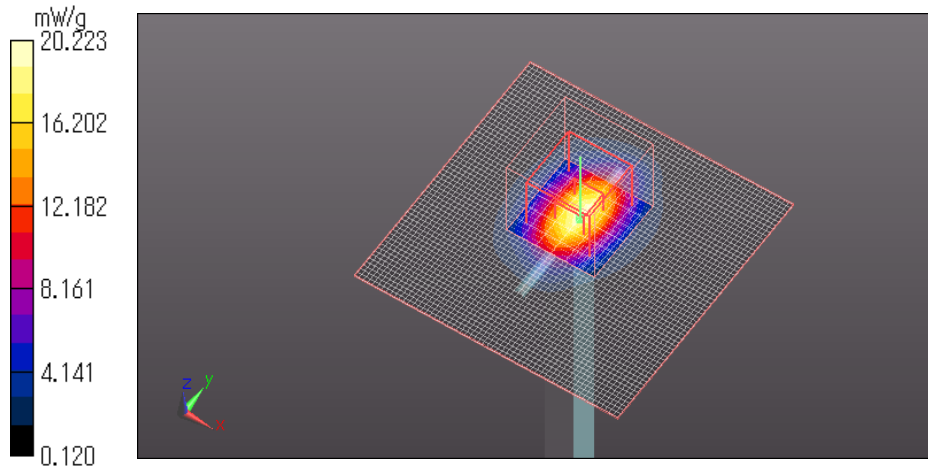

UL Japan, Inc.

Head Office EMC Lab.

4383-326 Asama-cho, Ise-shi, Mie-ken 516-0021 JAPAN

Telephone: +81 596 24 8116

Facsimile: +81 596 24 8124

System validation result for Body 2450

Simulated Tissue Liquid Parameter confirmation

DIELECTRIC PARAMETERS MEASUREMENT RESULTS										
Date	Ambient Temp. [deg.c]	Relative Humidity [%]	Liquid type	Liquid Temp. [deg.c]	Measured Frequency [MHz]	Parameters	Target Value*1	Measured	Deviation [%]	Limit [%]
2-Oct	24	54	MSL 2450	24.5	2450	ϵ_r	52.7	50.1	-4.9	+/-5
						σ [mho/m]	1.95	2.00	2.6	+/-5

ϵ_r : Relative Permittivity / σ : Conductivity

*1 The Target value is a parameter defined in FCC OET 65 .

DIELECTRIC PARAMETERS MEASUREMENT RESULTS										
Date	Ambient Temp. [deg.c]	Relative Humidity [%]	Liquid type	Liquid Temp. [deg.c]	Measured Frequency [MHz]	Parameters	Target Value*2	Measured	Deviation [%]	Limit*3 [%]
2-Oct	24	54	MSL 2450	24.5	2450	ϵ_r	52.5	50.1	-4.6	+/-6
						σ [mho/m]	1.95	2.00	2.6	+/-6

ϵ_r : Relative Permittivity / σ : Conductivity

*2 The target value is the calibrated dipole Body TSL parameters. (D2450V2 SN:713, Measured Body TSL parameters)

*3 The limit is for deviation provided by manufacture.

System validation result

SYSTEM VALIDATION							
Date	Frequency [MHz]	SAR 1g [W/kg]				Deviation [%]	Limit [%]
		Forward Power 250mW		Conversion 1W			
		Measured	Calculation	Target 1W *1			
2-Oct	2450.00	14.40	57.60	51.90	-9.9	+/-10	

*1 The target value is the parameter defined in 1g SAR (normalizes to 1W) in manufacturer calibrated dipole (D2450V2 SN:713)

UL Japan, Inc.

Head Office EMC Lab.

4383-326 Asama-cho, Ise-shi, Mie-ken 516-0021 JAPAN

Telephone: +81 596 24 8116

Facsimile: +81 596 24 8124

Body 2450MHz System Validation DATA / Dipole2.4GHz / Forward Conducted Power : 250mW

Communication System: CW; Communication System Band: D2450 (2450.0 MHz);

Frequency: 2450 MHz;Duty Cycle: 1:1

Medium parameters used: $f = 2450$ MHz; $\sigma = 2$ mho/m; $\epsilon_r = 50.1$; $\rho = 1000$ kg/m³

Phantom section: Flat Section

Measurement Standard: DASYS5 (IEEE/IEC/ANSI C63.19-2007)

DASY5 Configuration

Probe: EX3DV3 - SN3507; ConvF(7.61, 7.61, 7.61); Calibrated: 2011/03/16

Sensor-Surface: 2mm (Mechanical Surface Detection)

Electronics: DAE4 Sn509; Calibrated: 2011/07/20

Phantom: ELI 4.0; Type: QDOVA001BA;

Measurement SW: DASYS2, Version 52.6 (1);

Area Scan (61x61x1): Measurement grid: dx=15mm, dy=15mm

Maximum value of SAR (interpolated) = 22.182 mW/g

Zoom Scan (7x7x7)/Cube 0: Measurement grid: dx=5mm, dy=5mm, dz=5mm

Reference Value = 106.8 V/m; Power Drift = -0.09 dB

Peak SAR (extrapolated) = 30.131 W/kg

SAR(1 g) = 14.4 mW/g; SAR(10 g) = 6.63 mW/g

Maximum value of SAR (measured) = 22.098 mW/g

Date: 2011/10/02

Ambient Temp. : 24.0 degree.C. Liquid Temp.; 24.5 degree.C.

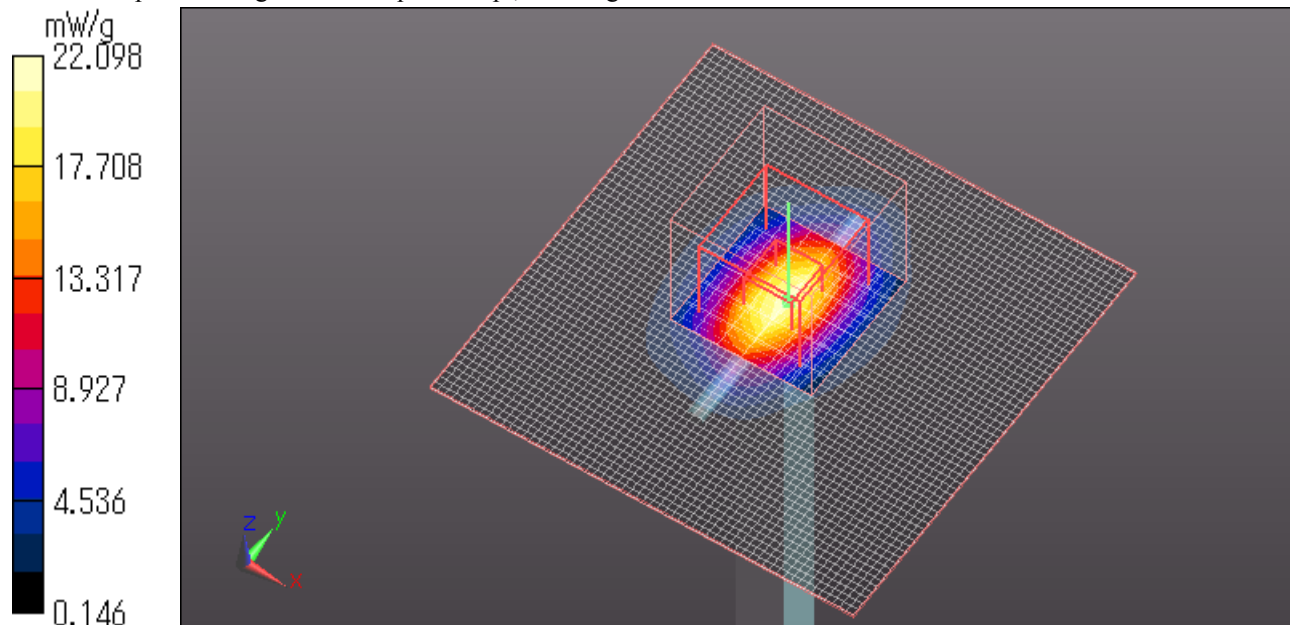

3. System Validation Dipole (D2450V2,S/N:713)

Calibration Laboratory of
Schmid & Partner
Engineering AG
Zeughausstrasse 43, 8004 Zurich, Switzerland



S Schweizerischer Kalibrierdienst
C Service suisse d'étalonnage
S Servizio svizzero di taratura
S Swiss Calibration Service

Accredited by the Swiss Accreditation Service (SAS)
The Swiss Accreditation Service is one of the signatories to the EA
Multilateral Agreement for the recognition of calibration certificates

Accreditation No.: SCS 108

Client **UL Japan (PTF)**

Certificate No: **D2450V2-713_Sep10**

CALIBRATION CERTIFICATE																																															
Object	D2450V2 - SN-713																																														
Calibration procedure(s)	QA CAL-05.v7 Calibration procedure for dipole validation kits																																														
Calibration date:	September 06, 2010																																														
<p>This calibration certificate documents the traceability to national standards, which realize the physical units of measurements (SI). The measurements and the uncertainties with confidence probability are given on the following pages and are part of the certificate.</p> <p>All calibrations have been conducted in the closed laboratory facility: environment temperature (22 ± 3)°C and humidity < 70%.</p> <p>Calibration Equipment used (M&TE critical for calibration)</p> <table border="1"> <thead> <tr> <th>Primary Standards</th> <th>ID #</th> <th>Cal Date (Certificate No.)</th> <th>Scheduled Calibration</th> </tr> </thead> <tbody> <tr> <td>Power meter EPM-442A</td> <td>GB37480704</td> <td>06-Oct-09 (No. 217-01086)</td> <td>Oct-10</td> </tr> <tr> <td>Power sensor HP 8481A</td> <td>US37282783</td> <td>08-Oct-09 (No. 217-01086)</td> <td>Oct-10</td> </tr> <tr> <td>Reference 20 dB Attenuator</td> <td>SN: 5086 (20g)</td> <td>30-Mar-10 (No. 217-01158)</td> <td>Mar-11</td> </tr> <tr> <td>Type-N mismatch combination</td> <td>SN: 5047.2 / 06327</td> <td>30-Mar-10 (No. 217-01162)</td> <td>Mar-11</td> </tr> <tr> <td>Reference Probe ES3DV3</td> <td>SN: 3205</td> <td>30-Apr-10 (No. ES3-3205_Apr10)</td> <td>Apr-11</td> </tr> <tr> <td>DAE4</td> <td>SN: 601</td> <td>10-Jun-10 (No. DAE4-601_Jun10)</td> <td>Jun-11</td> </tr> </tbody> </table> <table border="1"> <thead> <tr> <th>Secondary Standards</th> <th>ID #</th> <th>Check Date (in house)</th> <th>Scheduled Check</th> </tr> </thead> <tbody> <tr> <td>Power sensor HP 8481A</td> <td>MY41092317</td> <td>18-Oct-02 (in house check Oct-09)</td> <td>In house check: Oct-11</td> </tr> <tr> <td>RF generator R&S SMT-06</td> <td>100005</td> <td>4-Aug-99 (in house check Oct-09)</td> <td>In house check: Oct-11</td> </tr> <tr> <td>Network Analyzer HP 8753E</td> <td>US37390585 S4206</td> <td>18-Oct-01 (in house check Oct-09)</td> <td>In house check: Oct-10</td> </tr> </tbody> </table>				Primary Standards	ID #	Cal Date (Certificate No.)	Scheduled Calibration	Power meter EPM-442A	GB37480704	06-Oct-09 (No. 217-01086)	Oct-10	Power sensor HP 8481A	US37282783	08-Oct-09 (No. 217-01086)	Oct-10	Reference 20 dB Attenuator	SN: 5086 (20g)	30-Mar-10 (No. 217-01158)	Mar-11	Type-N mismatch combination	SN: 5047.2 / 06327	30-Mar-10 (No. 217-01162)	Mar-11	Reference Probe ES3DV3	SN: 3205	30-Apr-10 (No. ES3-3205_Apr10)	Apr-11	DAE4	SN: 601	10-Jun-10 (No. DAE4-601_Jun10)	Jun-11	Secondary Standards	ID #	Check Date (in house)	Scheduled Check	Power sensor HP 8481A	MY41092317	18-Oct-02 (in house check Oct-09)	In house check: Oct-11	RF generator R&S SMT-06	100005	4-Aug-99 (in house check Oct-09)	In house check: Oct-11	Network Analyzer HP 8753E	US37390585 S4206	18-Oct-01 (in house check Oct-09)	In house check: Oct-10
Primary Standards	ID #	Cal Date (Certificate No.)	Scheduled Calibration																																												
Power meter EPM-442A	GB37480704	06-Oct-09 (No. 217-01086)	Oct-10																																												
Power sensor HP 8481A	US37282783	08-Oct-09 (No. 217-01086)	Oct-10																																												
Reference 20 dB Attenuator	SN: 5086 (20g)	30-Mar-10 (No. 217-01158)	Mar-11																																												
Type-N mismatch combination	SN: 5047.2 / 06327	30-Mar-10 (No. 217-01162)	Mar-11																																												
Reference Probe ES3DV3	SN: 3205	30-Apr-10 (No. ES3-3205_Apr10)	Apr-11																																												
DAE4	SN: 601	10-Jun-10 (No. DAE4-601_Jun10)	Jun-11																																												
Secondary Standards	ID #	Check Date (in house)	Scheduled Check																																												
Power sensor HP 8481A	MY41092317	18-Oct-02 (in house check Oct-09)	In house check: Oct-11																																												
RF generator R&S SMT-06	100005	4-Aug-99 (in house check Oct-09)	In house check: Oct-11																																												
Network Analyzer HP 8753E	US37390585 S4206	18-Oct-01 (in house check Oct-09)	In house check: Oct-10																																												
Calibrated by:	Name Claudio Leubler	Function Laboratory Technician	Signature 																																												
Approved by:	Name Katja Pokovic	Function Technical Manager	Signature 																																												
			Issued: September 8, 2010																																												
This calibration certificate shall not be reproduced except in full without written approval of the laboratory.																																															

**Calibration Laboratory of
Schmid & Partner
Engineering AG**
Zeughausstrasse 43, 8004 Zurich, Switzerland



S Schweizerischer Kalibrierdienst
C Service suisse d'étalonnage
S Servizio svizzero di taratura
S Swiss Calibration Service

Accredited by the Swiss Accreditation Service (SAS)
The Swiss Accreditation Service is one of the signatories to the EA
Multilateral Agreement for the recognition of calibration certificates

Accreditation No.: **SCS 108**

Glossary:

TSL tissue simulating liquid
ConvF sensitivity in TSL / NORM x,y,z
N/A not applicable or not measured

Calibration is Performed According to the Following Standards:

- a) IEEE Std 1528-2003, "IEEE Recommended Practice for Determining the Peak Spatial-Averaged Specific Absorption Rate (SAR) in the Human Head from Wireless Communications Devices: Measurement Techniques", December 2003
- b) IEC 62209-1, "Procedure to measure the Specific Absorption Rate (SAR) for hand-held devices used in close proximity to the ear (frequency range of 300 MHz to 3 GHz)", February 2005
- c) Federal Communications Commission Office of Engineering & Technology (FCC OET), "Evaluating Compliance with FCC Guidelines for Human Exposure to Radiofrequency Electromagnetic Fields; Additional Information for Evaluating Compliance of Mobile and Portable Devices with FCC Limits for Human Exposure to Radiofrequency Emissions", Supplement C (Edition 01-01) to Bulletin 65

Additional Documentation:

- d) DASY4/5 System Handbook

Methods Applied and Interpretation of Parameters:

- *Measurement Conditions:* Further details are available from the Validation Report at the end of the certificate. All figures stated in the certificate are valid at the frequency indicated.
- *Antenna Parameters with TSL:* The dipole is mounted with the spacer to position its feed point exactly below the center marking of the flat phantom section, with the arms oriented parallel to the body axis.
- *Feed Point Impedance and Return Loss:* These parameters are measured with the dipole positioned under the liquid filled phantom. The impedance stated is transformed from the measurement at the SMA connector to the feed point. The Return Loss ensures low reflected power. No uncertainty required.
- *Electrical Delay:* One-way delay between the SMA connector and the antenna feed point. No uncertainty required.
- *SAR measured:* SAR measured at the stated antenna input power.
- *SAR normalized:* SAR as measured, normalized to an input power of 1 W at the antenna connector.
- *SAR for nominal TSL parameters:* The measured TSL parameters are used to calculate the nominal SAR result.

UL Japan, Inc.

Head Office EMC Lab.

4383-326 Asama-cho, Ise-shi, Mie-ken 516-0021 JAPAN

Telephone: +81 596 24 8116

Facsimile: +81 596 24 8124

Measurement Conditions

DASY system configuration, as far as not given on page 1.

DASY Version	DASY5	V52.2
Extrapolation	Advanced Extrapolation	
Phantom	Modular Flat Phantom V5.0	
Distance Dipole Center - TSL	10 mm	with Spacer
Zoom Scan Resolution	dx, dy, dz = 5 mm	
Frequency	2450 MHz \pm 1 MHz	

Head TSL parameters

The following parameters and calculations were applied.

	Temperature	Permittivity	Conductivity
Nominal Head TSL parameters	22.0 °C	39.2	1.80 mho/m
Measured Head TSL parameters	(22.0 \pm 0.2) °C	39.0 \pm 6 %	1.74 mho/m \pm 6 %
Head TSL temperature during test	(21.8 \pm 0.2) °C	----	----

SAR result with Head TSL

SAR averaged over 1 cm ³ (1 g) of Head TSL	Condition	
SAR measured	250 mW input power	12.9 mW / g
SAR normalized	normalized to 1W	51.6 mW / g
SAR for nominal Head TSL parameters	normalized to 1W	52.4 mW /g \pm 17.0 % (k=2)

SAR averaged over 10 cm ³ (10 g) of Head TSL	condition	
SAR measured	250 mW input power	6.08 mW / g
SAR normalized	normalized to 1W	24.3 mW / g
SAR for nominal Head TSL parameters	normalized to 1W	24.4 mW /g \pm 16.5 % (k=2)

Body TSL parameters

The following parameters and calculations were applied.

	Temperature	Permittivity	Conductivity
Nominal Body TSL parameters	22.0 °C	52.7	1.95 mho/m
Measured Body TSL parameters	(22.0 ± 0.2) °C	52.5 ± 6 %	1.95 mho/m ± 6 %
Body TSL temperature during test	(22.0 ± 0.2) °C	----	----

SAR result with Body TSL

SAR averaged over 1 cm ³ (1 g) of Body TSL	Condition	
SAR measured	250 mW input power	13.0 mW / g
SAR normalized	normalized to 1W	52.0 mW / g
SAR for nominal Body TSL parameters	normalized to 1W	51.9 mW / g ± 17.0 % (k=2)

SAR averaged over 10 cm ³ (10 g) of Body TSL	condition	
SAR measured	250 mW input power	6.04 mW / g
SAR normalized	normalized to 1W	24.2 mW / g
SAR for nominal Body TSL parameters	normalized to 1W	24.1 mW / g ± 16.5 % (k=2)

Appendix**Antenna Parameters with Head TSL**

Impedance, transformed to feed point	53.0 Ω + 1.0 j Ω
Return Loss	- 30.4 dB

Antenna Parameters with Body TSL

Impedance, transformed to feed point	49.6 Ω + 2.1 j Ω
Return Loss	- 33.5 dB

General Antenna Parameters and Design

Electrical Delay (one direction)	1.160 ns
----------------------------------	----------

After long term use with 100W radiated power, only a slight warming of the dipole near the feedpoint can be measured.

The dipole is made of standard semirigid coaxial cable. The center conductor of the feeding line is directly connected to the second arm of the dipole. The antenna is therefore short-circuited for DC-signals.

No excessive force must be applied to the dipole arms, because they might bend or the soldered connections near the feedpoint may be damaged.

Additional EUT Data

Manufactured by	SPEAG
Manufactured on	July 05, 2002

DASY5 Validation Report for Head TSL

Date/Time: 03.09.2010 15:07:26

Test Laboratory: SPEAG, Zurich, Switzerland

DUT: Dipole 2450 MHz; Type: D2450V2; Serial: D2450V2 - SN:713

Communication System: CW; Frequency: 2450 MHz; Duty Cycle: 1:1

Medium: HSL U12 BB

Medium parameters used: $f = 2450$ MHz; $\sigma = 1.74$ mho/m; $\epsilon_r = 39$; $\rho = 1000$ kg/m³

Phantom section: Flat Section

Measurement Standard: DASY5 (IEEE/IEC/ANSI C63.19-2007)

DASY5 Configuration:

- Probe: ES3DV3 - SN3205; ConvF(4.53, 4.53, 4.53); Calibrated: 30.04.2010
- Sensor-Surface: 3mm (Mechanical Surface Detection)
- Electronics: DAE4 Sn601; Calibrated: 10.06.2010
- Phantom: Flat Phantom 5.0 (front); Type: QD000P50AA; Serial: 1001
- Measurement SW: DASY52, V52.2 Build 0, Version 52.2.0 (163)
- Postprocessing SW: SEMCAD X, V14.2 Build 2, Version 14.2.2 (1685)

Head/d=10mm, Pin=250 mW, dist=3.0mm (ES-Probe)/Zoom Scan (7x7x7) (7x7x7)/Cube 0:

Measurement grid: dx=5mm, dy=5mm, dz=5mm

Reference Value = 100.4 V/m; Power Drift = 0.050 dB

Peak SAR (extrapolated) = 26.3 W/kg

SAR(1 g) = 12.9 mW/g; SAR(10 g) = 6.08 mW/g

Maximum value of SAR (measured) = 16.2 mW/g

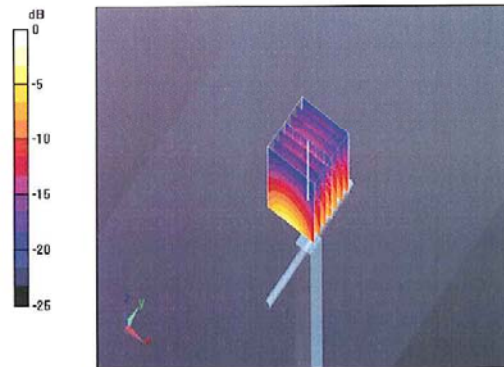

0 dB = 16.2mW/g

Impedance Measurement Plot for Head TSL

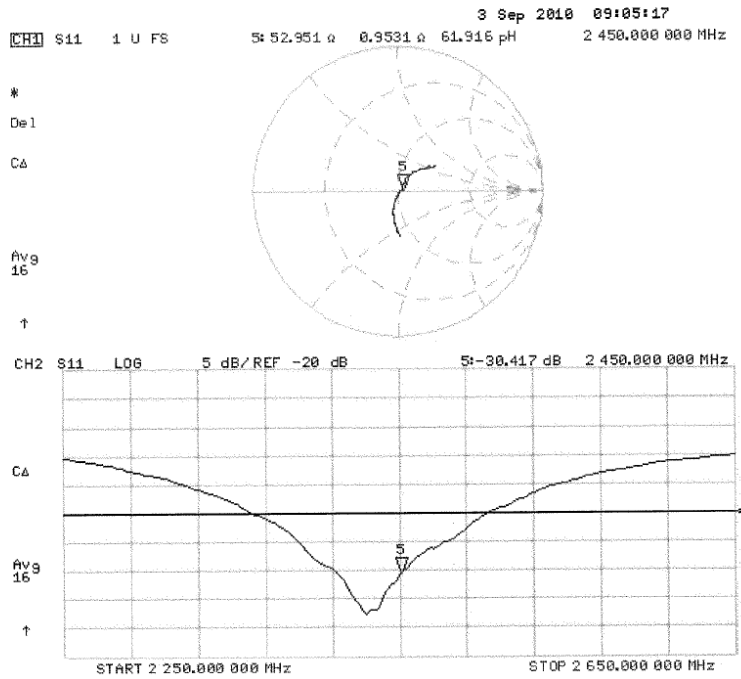

Validation Report for Body

Date/Time: 06.09.2010 13:42:13

Test Laboratory: SPEAG, Zurich, Switzerland

DUT: Dipole 2450 MHz; Type: D2450V2; Serial: D2450V2 - SN:713

Communication System: CW; Frequency: 2450 MHz; Duty Cycle: 1:1

Medium: MSL U12 BB

Medium parameters used: $f = 2450$ MHz; $\sigma = 1.95$ mho/m; $\epsilon_r = 52.5$; $\rho = 1000$ kg/m³

Phantom section: Flat Section

Measurement Standard: DASYS (IEEE/IEC/ANSI C63.19-2007)

DASY5 Configuration:

- Probe: ES3DV3 - SN3205; ConvF(4.31, 4.31, 4.31); Calibrated: 30.04.2010
- Sensor-Surface: 3mm (Mechanical Surface Detection)
- Electronics: DAE4 Sn601; Calibrated: 10.06.2010
- Phantom: Flat Phantom 5.0 (back); Type: QD000P50AA; Serial: 1002
- Measurement SW: DASYS2, V52.2 Build 0, Version 52.2.0 (163)
- Postprocessing SW: SEMCAD X, V14.2 Build 2, Version 14.2.2 (1685)

Body/d=10mm, Pin=250 mW, dist=3.0mm (ES-Probe)/Zoom Scan (7x7x7) (7x7x7)/Cube 0:

Measurement grid: dx=5mm, dy=5mm, dz=5mm

Reference Value = 95.7 V/m; Power Drift = 0.030 dB

Peak SAR (extrapolated) = 27 W/kg

SAR(1 g) = 13 mW/g; SAR(10 g) = 6.04 mW/g

Maximum value of SAR (measured) = 16.9 mW/g

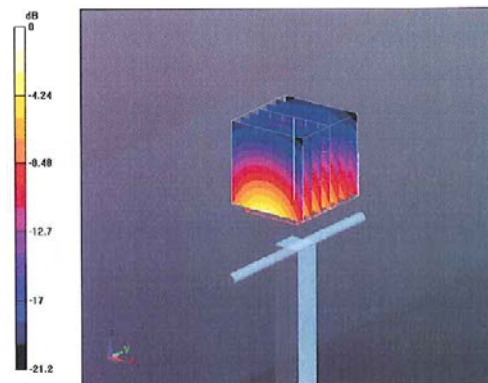

0 dB = 16.9mW/g

Impedance Measurement Plot for Body TSL

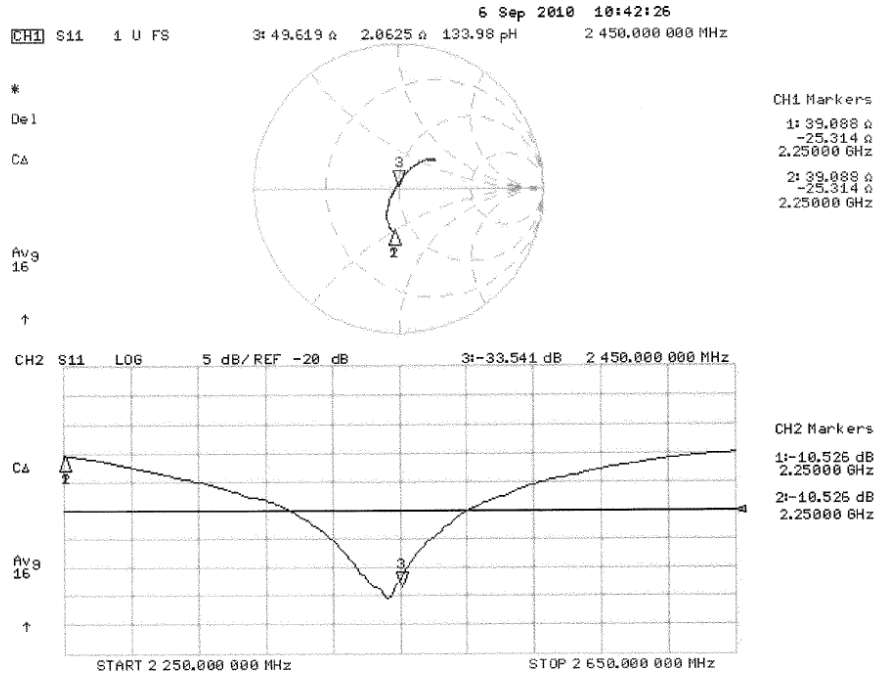

D2450V2 Calibration for Impedance and Return-loss

Date	September 13, 2011		
Ambient Temperature	24.5 deg.C	Relative humidity	63%RH

1. Test environment

Equipment	Dipole Antenna	Model	D2450V2
Manufacture	Schmid&Partner Engineering AG	Serial	713
Tested by	Miyo Kishimoto/ISE/ULI		

2. Equipment used

Control No.	Instrument	Manufacturer	Model No	Serial No	Calibration Date * Interval(month)
MNA-01	Network Analyzer	Agilent/HP	E8358A	US41080381	2011/08/22* 12
MNCK-01	Type N Calibration Kit	Agilent	85032F	MY41495257	2011/08/12 * 12
EST-46	3.5mm Calibration Kit	Agilent	85052D	MY43252869	2011/06/13*12
MDA-12	Dipole Antenna	Schmid&Partner Engineering AG	D1450V2	1024	2009/06/23 * 36
MPSAM-02	SAM Phantom	Schmid&Partner Engineering AG	SAM Twin Phantom V4.0	1333	Pre Check
MOS-24	Thermo-Hygrometer	Custom	CTH-201	0005	2011/02/23 * 12
HSL2450					Daily check
MSL2450					Daily check
SAR room					Daily check

3. Test Result

Impedance, Transformed to feed point	Head	Deviation	Tolerance	Result
Calibration (SPEAG) 2010/9/06	53.0 Ω +1.0j Ω	-	-	-
Calibration(ULJ)2011/9/13	52.27 Ω -0.57j Ω	-0.73 Ω -1.57j Ω	+/-5 Ω +/-5j Ω	Complied

Return loss	Head	Deviation	Tolerance	Result
Calibration (SPEAG) 2010/9/06	-30.4dB	-	-	-
Calibration(ULJ)2011/9/13	-32.79dB	-2.39dB	30.4 *+/-20%	Complied

Impedance, Transformed to feed point	Body	Deviation	Tolerance	Result
Calibration (SPEAG) 2010/9/06	49.6 Ω +2.1j Ω	-	-	-
Calibration(ULJ)2011/9/13	48.28 Ω +0.35j Ω	-1.32 Ω -1.75j Ω	+/-5 Ω +/-5j Ω	Complied

Return loss	Body	Deviation	Tolerance	Result
Calibration (SPEAG) 2010/9/06	-33.5dB	-	-	-
Calibration(ULJ)2011/9/13	-34.98dB	-1.48dB	33.5*+/-20%	Complied

*Tolerance : According to the KDB450824D02

UL Japan, Inc.

Head Office EMC Lab.

4383-326 Asama-cho, Ise-shi, Mie-ken 516-0021 JAPAN

Telephone: +81 596 24 8116

Facsimile: +81 596 24 8124

Measurement Plots

<Head Liquid>

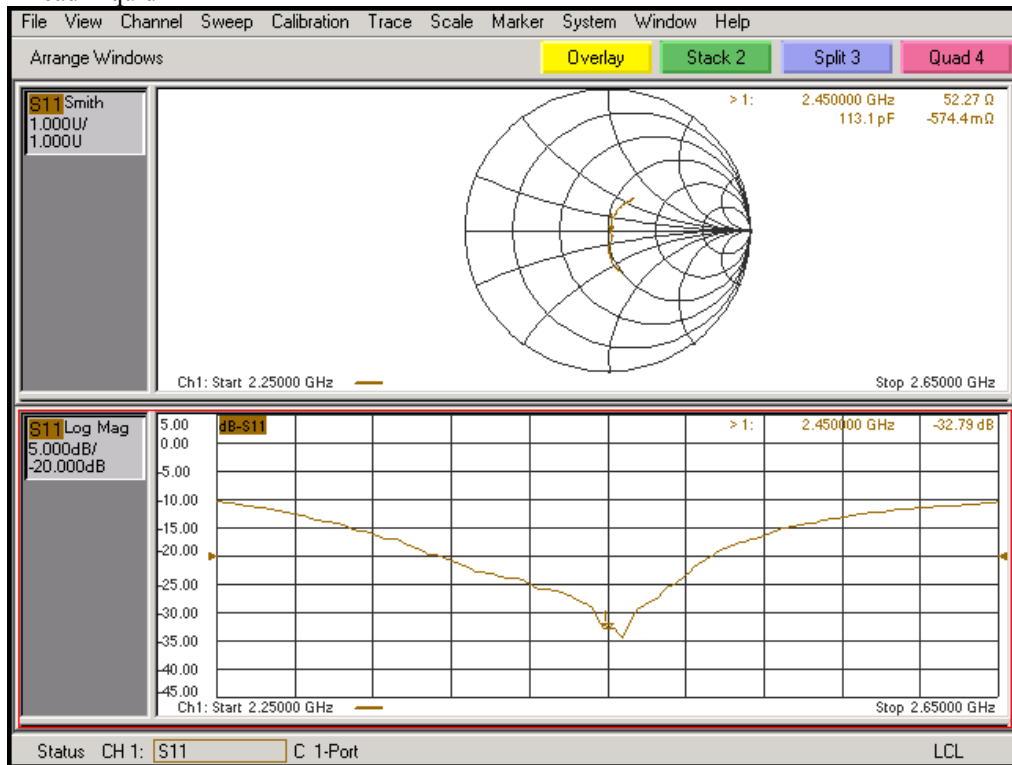

<Body Liquid>

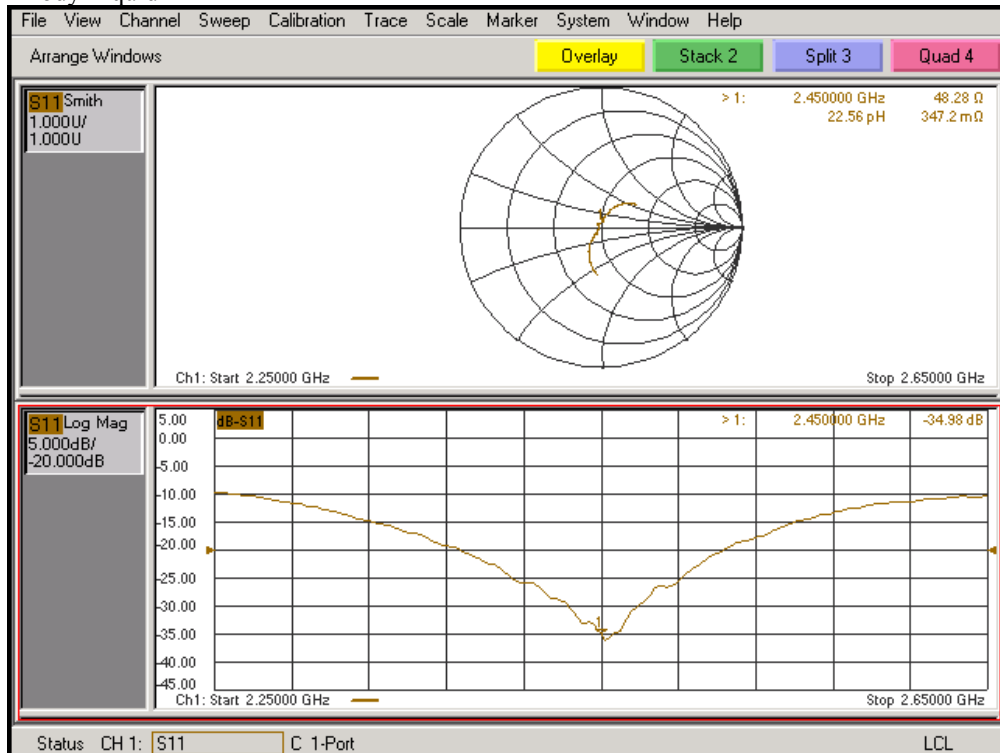

UL Japan, Inc.

Head Office EMC Lab.

4383-326 Asama-cho, Ise-shi, Mie-ken 516-0021 JAPAN

Telephone: +81 596 24 8116

Facsimile: +81 596 24 8124

4. System validation result 5GHz**System validation result for Head 5GHz****Simulated Tissue Liquid Parameter confirmation**

DIELECTRIC PARAMETERS MEASUREMENT RESULTS										
Date	Ambient Temp. [deg.c]	Relative Humidity [%]	Liquid type	Liquid Temp. [deg.c]	Measured Frequency [MHz]	Parameters	Target Value*1	Measured	Deviation [%]	Limit [%]
5-Nov	24	55	HSL 3-6GHz	23.5	5200	ϵ_r	36.0	34.8	-3.3	+/-5
						σ [mho/m]	4.66	4.78	2.6	+/-5
10-Oct	24	61	HSL 3-6GHz	23.5	5500	ϵ_r	35.6	34.4	-3.4	+/-5
						σ [mho/m]	4.96	5.14	3.6	+/-5
5-Nov	24	55	HSL 3-6GHz	23.5	5500	ϵ_r	35.6	34.1	-4.2	+/-5
						σ [mho/m]	4.96	5.10	2.8	+/-5
5-Nov	24	55	HSL 3-6GHz	23.5	5800	ϵ_r	35.3	33.6	-4.8	+/-5
						σ [mho/m]	5.27	5.46	3.6	+/-5

ϵ_r : Relative Permittivity / σ : Conductivity

*1 The Target value is a parameter defined in FCC OET 65.

System validation result

SYSTEM VALIDATION							
Date	Frequency [MHz]	SAR 1g [W/kg]			Target 1W *1	Deviation [%]	Limit [%]
		Forward Power 100mW	Conversion 1W				
		Measured	Calculation				
5-Nov	5200	7.84	78.40		75.7	3.6	+/-10
10-Oct	5500	8.66	86.60		78.9	9.8	+/-10
5-Nov	5500	8.43	84.30		78.9	6.8	+/-10
5-Nov	5800	7.82	78.20		72.8	7.4	+/-10

*1 The target value is the parameter defined in 1g SAR (normalizes to 1W) in manufacturer calibrated dipole (D5GHzV2 SN:1020)

UL Japan, Inc.

Head Office EMC Lab.

4383-326 Asama-cho, Ise-shi, Mie-ken 516-0021 JAPAN

Telephone: +81 596 24 8116

Facsimile: +81 596 24 8124

5200MHz System Validation DATA / Dipole5GHz / Forward Conducted Power : 100mW

Communication System: CW; Communication System Band: Exported from older format (data unavailable - please correct).; Frequency: 5200 MHz; Duty Cycle: 1:1

Medium parameters used: $f = 5200$ MHz; $\sigma = 4.78$ mho/m; $\epsilon_r = 34.8$; $\rho = 1000$ kg/m³

Phantom section: Flat Section

Measurement Standard: DASYS5 (IEEE/IEC/ANSI C63.19-2007)

DASY5 Configuration

Probe: EX3DV4 - SN3540; ConvF(4.71, 4.71, 4.71); Calibrated: 2011/07/21

Sensor-Surface: 2mm (Mechanical Surface Detection)

Electronics: DAE4 Sn509; Calibrated: 2011/07/20

Phantom: ELI 4.0; Type: QDOVA001BA;

Measurement SW: DASYS2, Version 52.6 (1);

Area Scan (81x81x1): Measurement grid: dx=10mm, dy=10mm

Maximum value of SAR (interpolated) = 16.242 mW/g

Zoom Scan (8x8x10)/Cube 0: Measurement grid: dx=4mm, dy=4mm, dz=2.5mm

Reference Value = 62.312 V/m; Power Drift = 0.07 dB

Peak SAR (extrapolated) = 32.182 W/kg

SAR(1 g) = 7.84 mW/g; SAR(10 g) = 2.22 mW/g

Maximum value of SAR (measured) = 15.513 mW/g

Date: 2011/11/04

Ambient Temp. : 24.0 degree.C. Liquid Temp.; 23.5 degree.C.

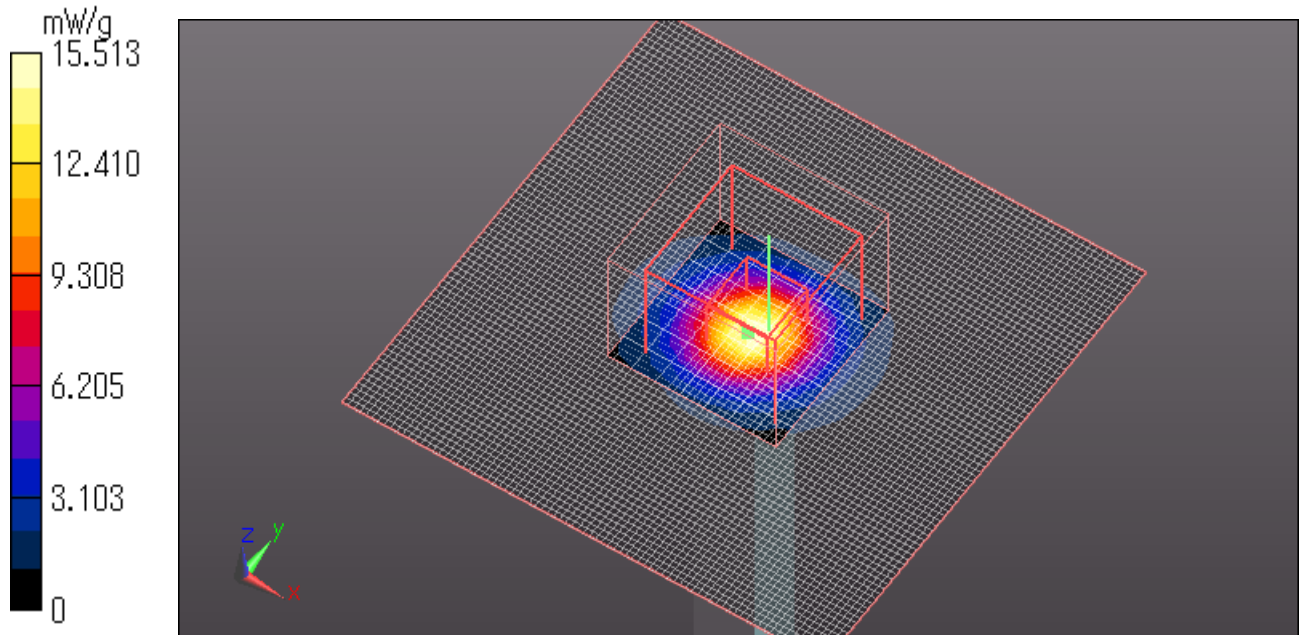

UL Japan, Inc.

Head Office EMC Lab.

4383-326 Asama-cho, Ise-shi, Mie-ken 516-0021 JAPAN

Telephone: +81 596 24 8116

Facsimile: +81 596 24 8124

5500MHz System Validation DATA / Dipole5GHz / Forward Conducted Power : 100mW

Communication System: CW; Communication System Band: Exported from older format (data unavailable - please correct).; Frequency: 5500 MHz; Duty Cycle: 1:1

Medium parameters used: $f = 5500$ MHz; $\sigma = 5.14$ mho/m; $\epsilon_r = 34.4$; $\rho = 1000$ kg/m³

Phantom section: Flat Section

Measurement Standard: DASYS5 (IEEE/IEC/ANSI C63.19-2007)

DASY5 Configuration

Probe: EX3DV4 - SN3679; ConvF(4.27, 4.27, 4.27); Calibrated: 2011/05/19

Sensor-Surface: 2mm (Mechanical Surface Detection)

Electronics: DAE4 Sn509; Calibrated: 2011/07/20

Phantom: ELI 4.0; Type: QDOVA001BA;

Measurement SW: DASYS2, Version 52.6 (1);

Area Scan (81x81x1): Measurement grid: dx=10mm, dy=10mm

Maximum value of SAR (interpolated) = 18.296 mW/g

Zoom Scan (8x8x10)/Cube 0: Measurement grid: dx=4mm, dy=4mm, dz=2.5mm

Reference Value = 65.629 V/m; Power Drift = 0.06 dB

Peak SAR (extrapolated) = 35.576 W/kg

SAR(1 g) = 8.66 mW/g; SAR(10 g) = 2.43 mW/g

Maximum value of SAR (measured) = 17.472 mW/g

Date: 2011/10/10

Ambient Temp. : 24.0 degree.C. Liquid Temp.; 23.5 degree.C.

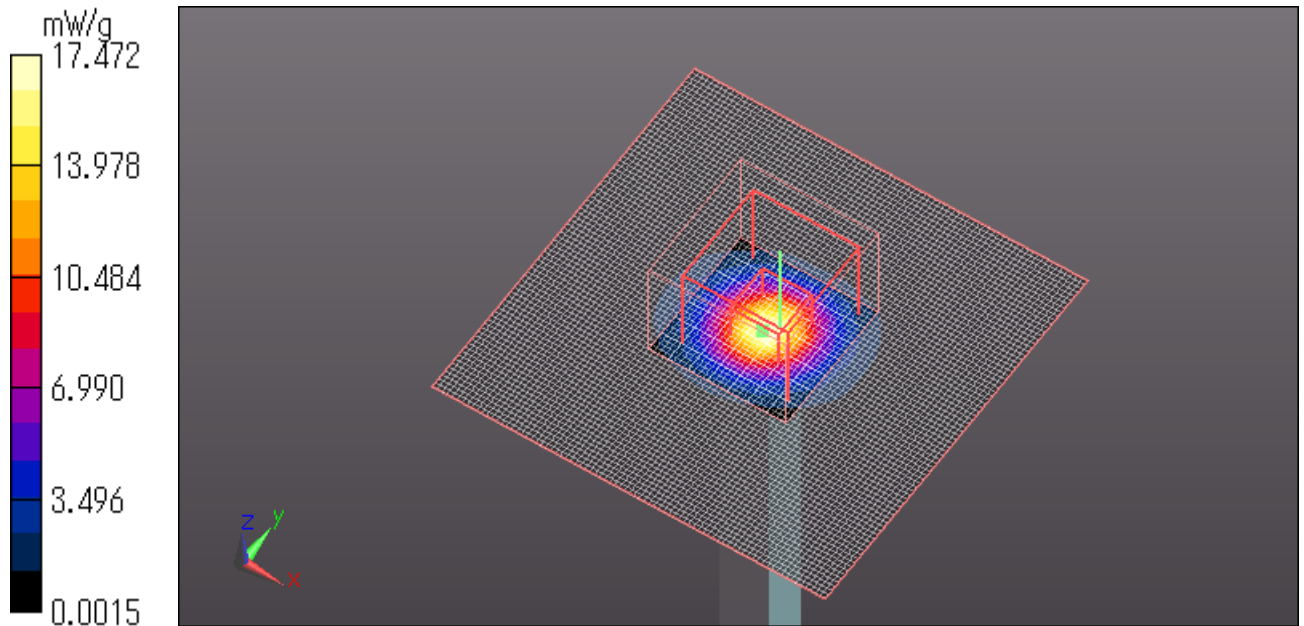

UL Japan, Inc.

Head Office EMC Lab.

4383-326 Asama-cho, Ise-shi, Mie-ken 516-0021 JAPAN

Telephone: +81 596 24 8116

Facsimile: +81 596 24 8124

5500MHz System Validation DATA / Dipole5GHz / Forward Conducted Power : 100mW

Communication System: CW; Communication System Band: Exported from older format (data unavailable - please correct).; Frequency: 5500 MHz; Duty Cycle: 1:1

Medium parameters used: $f = 5500$ MHz; $\sigma = 5.1$ mho/m; $\epsilon_r = 34.1$; $\rho = 1000$ kg/m³

Phantom section: Flat Section

Measurement Standard: DASYS5 (IEEE/IEC/ANSI C63.19-2007)

DASY5 Configuration

Probe: EX3DV4 - SN3540; ConvF(4.3, 4.3, 4.3); Calibrated: 2011/07/21

Sensor-Surface: 2mm (Mechanical Surface Detection)

Electronics: DAE4 Sn509; Calibrated: 2011/07/20

Phantom: ELI 4.0; Type: QDOVA001BA;

Measurement SW: DASYS2, Version 52.6 (1);

Area Scan (81x81x1): Measurement grid: dx=10mm, dy=10mm

Maximum value of SAR (interpolated) = 17.478 mW/g

Zoom Scan(8x8x10)/Cube 0: Measurement grid: dx=4mm, dy=4mm, dz=2.5mm

Reference Value = 62.911 V/m; Power Drift = -0.04 dB

Peak SAR (extrapolated) = 34.978 W/kg

SAR(1 g) = 8.43 mW/g; SAR(10 g) = 2.36 mW/g

Maximum value of SAR (measured) = 16.838 mW/g

Date: 2011/11/04

Ambient Temp. : 24.0 degree.C. Liquid Temp.; 23.5 degree.C.

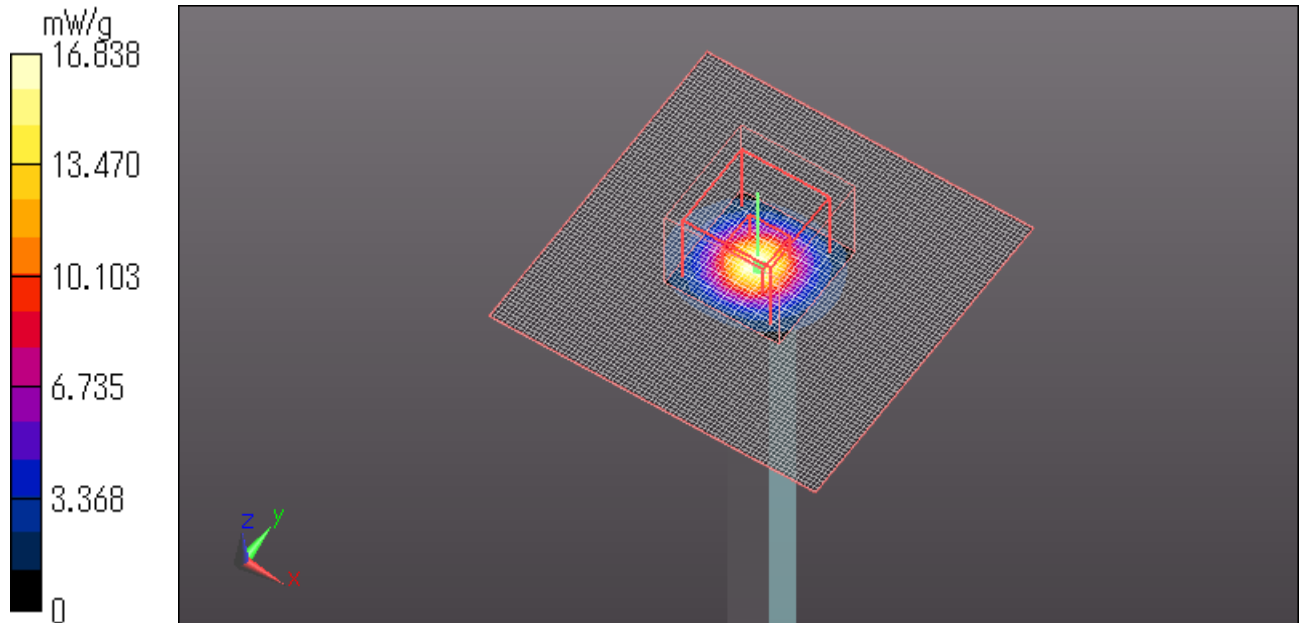

UL Japan, Inc.

Head Office EMC Lab.

4383-326 Asama-cho, Ise-shi, Mie-ken 516-0021 JAPAN

Telephone: +81 596 24 8116

Facsimile: +81 596 24 8124

5800MHz System Validation DATA / Dipole5GHz / Forward Conducted Power : 100mW

Communication System: CW; Communication System Band: Exported from older format (data unavailable - please correct).; Frequency: 5800 MHz;Duty Cycle: 1:1

Communication System: WLAN 11a/b/g/n ; Communication System Band: 11a/n; Frequency: 5800 MHz;Duty Cycle: 1:1

Medium parameters used: $f = 5800$ MHz; $\sigma = 5.46$ mho/m; $\epsilon_r = 33.6$; $\rho = 1000$ kg/m³

Phantom section: Flat Section

Measurement Standard: DASYS5 (IEEE/IEC/ANSI C63.19-2007)

DASY5 Configuration

Probe: EX3DV4 - SN3540; ConvF(4.16, 4.16, 4.16); Calibrated: 2011/07/21

Sensor-Surface: 2mm (Mechanical Surface Detection)

Electronics: DAE4 Sn509; Calibrated: 2011/07/20

Phantom: ELI 4.0; Type: QDOVA001BA;

Measurement SW: DASYS2, Version 52.6 (1);

Area Scan (51x51x1): Measurement grid: dx=10mm, dy=10mm

Maximum value of SAR (interpolated) = 16.913 mW/g

Zoom Scan (8x8x10)/Cube 0: Measurement grid: dx=4mm, dy=4mm, dz=2.5mm

Reference Value = 64.581 V/m; Power Drift = -0.02 dB

Peak SAR (extrapolated) = 34.390 W/kg

SAR(1 g) = 7.82 mW/g; SAR(10 g) = 2.19 mW/g

Maximum value of SAR (measured) = 15.687 mW/g

Date: 2011/11/04

Ambient Temp. : 24.0 degree.C. Liquid Temp.; 23.5 degree.C.

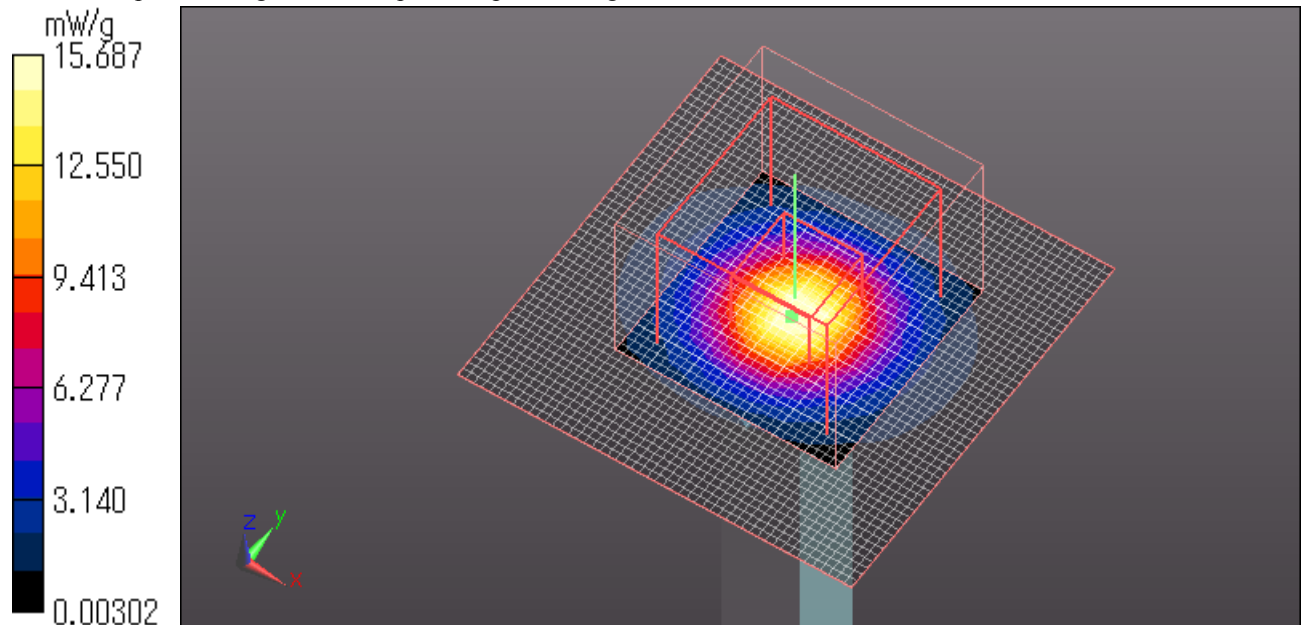

UL Japan, Inc.

Head Office EMC Lab.

4383-326 Asama-cho, Ise-shi, Mie-ken 516-0021 JAPAN

Telephone: +81 596 24 8116

Facsimile: +81 596 24 8124

System validation result for Body 5GHz**Simulated Tissue Liquid Parameter confirmation**

DIELECTRIC PARAMETERS MEASUREMENT RESULTS										
Date	Ambient Temp. [deg.c]	Relative Humidity [%]	Liquid type	Liquid Temp. [deg.c]	Measured Frequency [MHz]	Parameters	Target Value*1	Measured	Deviation [%]	Limit [%]
5-Nov	24.5	66	MSL 3-6GHz	24.5	5200	ϵ_r	49.0	47.1	-3.9	+/-5
						σ [mho/m]	5.30	5.42	2.3	+/-5
6-Oct	24.5	60	MSL 3-6GHz	24.5	5500	ϵ_r	48.6	46.8	-3.7	+/-5
						σ [mho/m]	5.65	5.82	3.0	+/-5
5-Nov	24.5	66	MSL 3-6GHz	24.5	5500	ϵ_r	48.6	46.5	-4.3	+/-5
						σ [mho/m]	5.65	5.83	3.2	+/-5
6-Nov	24.6	54	MSL 3-6GHz	24.2	5800	ϵ_r	48.2	45.9	-4.8	+/-5
						σ [mho/m]	6.00	6.29	4.8	+/-5

ϵ_r : Relative Permittivity / σ : Conductivity

*1 The Target value is a parameter defined in FCC OET65.

DIELECTRIC PARAMETERS MEASUREMENT RESULTS										
Date	Ambient Temp. [deg.c]	Relative Humidity [%]	Liquid type	Liquid Temp. [deg.c]	Measured Frequency [MHz]	Parameters	Target Value*2	Measured	Deviation [%]	Limit*3 [%]
5-Nov	24.5	66	MSL 3-6GHz	24.5	5200	ϵ_r	48.8	47.1	-3.5	+/-6
						σ [mho/m]	5.45	5.42	-0.6	+/-6
5-Nov	24.5	60	MSL 3-6GHz	24.5	5500	ϵ_r	48.6	46.8	-3.7	+/-6
						σ [mho/m]	5.86	5.82	-0.7	+/-6
6-Oct	24.5	66	MSL 3-6GHz	24.5	5500	ϵ_r	48.6	46.5	-4.3	+/-6
						σ [mho/m]	5.86	5.83	-0.5	+/-6
6-Nov	24.6	54	MSL 3-6GHz	24.2	5800	ϵ_r	48.2	45.9	-4.8	+/-6
						σ [mho/m]	6.27	6.29	0.3	+/-6

ϵ_r : Relative Permittivity / σ : Conductivity

*2 The target value is the calibrated dipole Body TSL parameters. (D5GHzV2 SN:1020, Measured Body TSL parameters)

*3 The limit is for deviation provided by manufacture.

System validation result

SYSTEM VALIDATION							
Date	Frequency [MHz]	SAR 1g [W/kg]				Deviation [%]	Limit [%]
		Forward Power 100mW		Conversion 1W			
		Measured	Calculation	Target 1W *1			
5-Nov	5200	8.19	81.90		75.10	9.1	+/-10
6-Oct	5500	8.61	86.10		79.90	7.8	+/-10
5-Nov	5500	8.39	83.90		79.90	5.0	+/-10
6-Nov	5800	8.13	81.30		74.40	9.3	+/-10

*1 The target value is the parameter defined in 1g SAR (normalizes to 1W) in manufacturer calibrated dipole (D5GHzV2 SN:1020)

UL Japan, Inc.

Head Office EMC Lab.

4383-326 Asama-cho, Ise-shi, Mie-ken 516-0021 JAPAN

Telephone: +81 596 24 8116

Facsimile: +81 596 24 8124

Body 5200MHz System Validation DATA / Dipole5GHz / Forward Conducted Power : 100mW

Communication System: CW; Communication System Band: Exported from older format (data unavailable - please correct).; Frequency: 5200 MHz; Duty Cycle: 1:1

Medium parameters used: $f = 5200$ MHz; $\sigma = 5.42$ mho/m; $\epsilon_r = 47.1$; $\rho = 1000$ kg/m³

Phantom section: Flat Section

Measurement Standard: DASY5 (IEEE/IEC/ANSI C63.19-2007)

DASY5 Configuration

Probe: EX3DV4 - SN3540; ConvF(3.94, 3.94, 3.94); Calibrated: 2011/07/21

Sensor-Surface: 2mm (Mechanical Surface Detection)

Electronics: DAE4 Sn509; Calibrated: 2011/07/20

Phantom: ELI 4.0; Type: QDOVA001BA;

Measurement SW: DASY52, Version 52.6 (1);

Area Scan (81x81x1): Measurement grid: dx=10mm, dy=10mm

Maximum value of SAR (interpolated) = 16.777 mW/g

Zoom Scan (8x8x10)/Cube 0: Measurement grid: dx=4mm, dy=4mm, dz=2.5mm

Reference Value = 63.733 V/m; Power Drift = -0.05 dB

Peak SAR (extrapolated) = 32.150 W/kg

SAR(1 g) = 8.19mW/g; SAR(10 g) = 2.21 mW/g

Maximum value of SAR (measured) = 15.513 mW/g

Date: 2011/11/05

Ambient Temp. : 24.0 degree.C. Liquid Temp.; 23.5 degree.C.

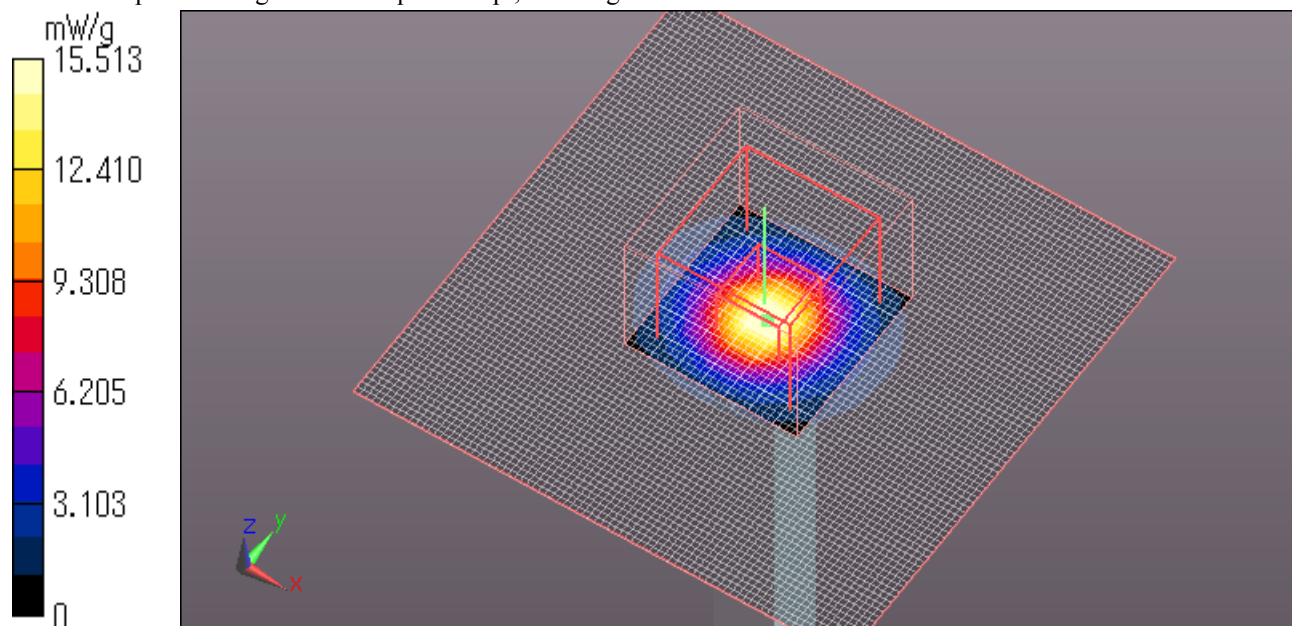

Body 5500MHz System Validation DATA / Dipole5GHz / Forward Conducted Power : 100mW

Communication System: CW; Communication System Band: D5GHz (5000.0 - 6000.0 MHz); Frequency: 5500 MHz; Duty Cycle: 1:1

Medium parameters used: $f = 5500$ MHz; $\sigma = 5.82$ mho/m; $\epsilon_r = 46.8$; $\rho = 1000$ kg/m³

Phantom section: Flat Section

Measurement Standard: DASYS (IEEE/IEC/ANSI C63.19-2007)

DASY5 Configuration

Probe: EX3DV3 - SN3507; ConvF(3.7, 3.7, 3.7); Calibrated: 2011/03/16

Sensor-Surface: 2mm (Mechanical Surface Detection)

Electronics: DAE4 Sn509; Calibrated: 2011/07/20

Phantom: ELI 4.0; Type: QDOVA001BA;

Measurement SW: DASYS2, Version 52.6 (1);

Area Scan (81x81x1): Measurement grid: dx=10mm, dy=10mm

Maximum value of SAR (interpolated) = 17.868 mW/g

Zoom Scan (8x8x10)/Cube 0: Measurement grid: dx=4mm, dy=4mm, dz=2.5mm

Reference Value = 54.007 V/m; Power Drift = -0.09 dB

Peak SAR (extrapolated) = 32.765 W/kg

SAR(1 g) = 8.61 mW/g; SAR(10 g) = 2.42 mW/g

Maximum value of SAR (measured) = 17.084 mW/g

Date: 2011/10/06

Ambient Temp. : 24.5 degree.C. Liquid Temp.; 24.5 degree.C.

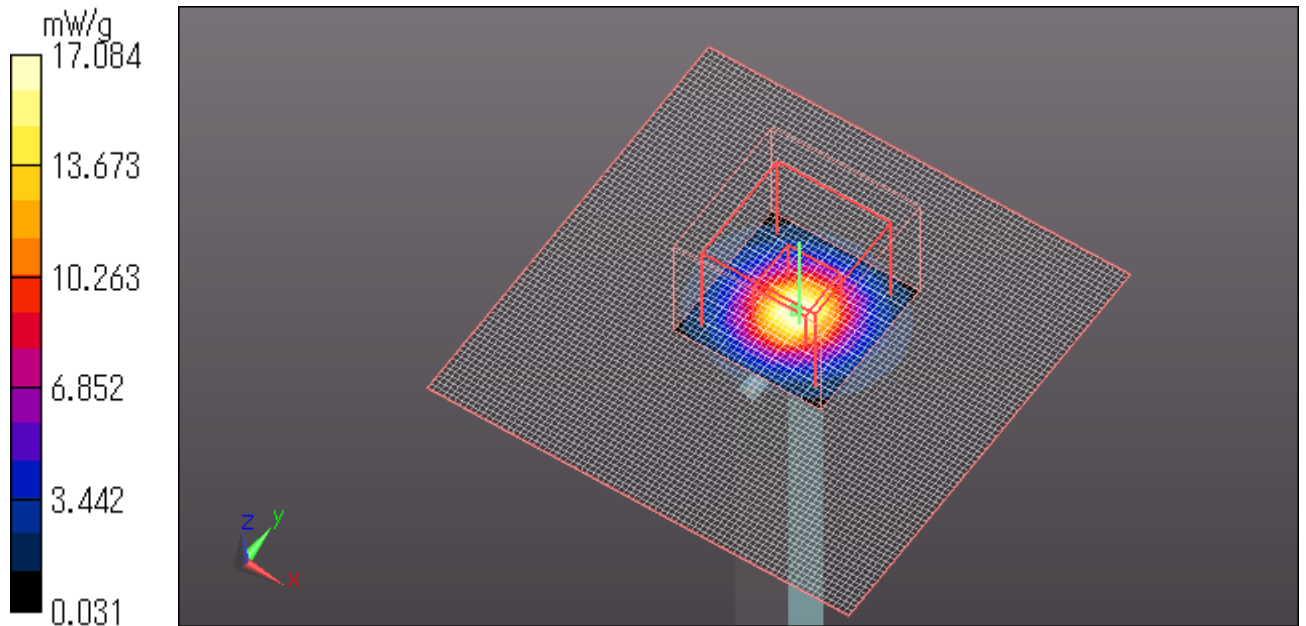

Body 5500MHz System Validation DATA / Dipole5GHz / Forward Conducted Power : 100mW

Communication System: WLAN 11a/b/g/n ; Communication System Band: 11a/n; Frequency: 5500 MHz;Duty Cycle: 1:1

Medium parameters used: $f = 5500$ MHz; $\sigma = 5.83$ mho/m; $\epsilon_r = 46.5$; $\rho = 1000$ kg/m³

Phantom section: Flat Section

Measurement Standard: DASYS (IEEE/IEC/ANSI C63.19-2007)

DASY5 Configuration

Probe: EX3DV4 - SN3540; ConvF(3.56, 3.56, 3.56); Calibrated: 2011/07/21

Sensor-Surface: 2mm (Mechanical Surface Detection)

Electronics: DAE4 Sn509; Calibrated: 2011/07/20

Phantom: ELI 4.0; Type: QDOVA001BA;

Measurement SW: DASYS2, Version 52.6 (1);

Area Scan (81x81x1): Measurement grid: dx=10mm, dy=10mm

Maximum value of SAR (interpolated) = 17.127 mW/g

Zoom Scan (8x8x10)/Cube 0: Measurement grid: dx=4mm, dy=4mm, dz=2.5mm

Reference Value = 1.659 V/m; Power Drift = -0.10 dB

Peak SAR (extrapolated) = 32.545 W/kg

SAR(1 g) = 8.39 mW/g; SAR(10 g) = 2.33 mW/g

Maximum value of SAR (measured) = 16.767 mW/g

Date: 2011/11/05

Ambient Temp. : 24.5 degree.C. Liquid Temp.; 24.5 degree.C.

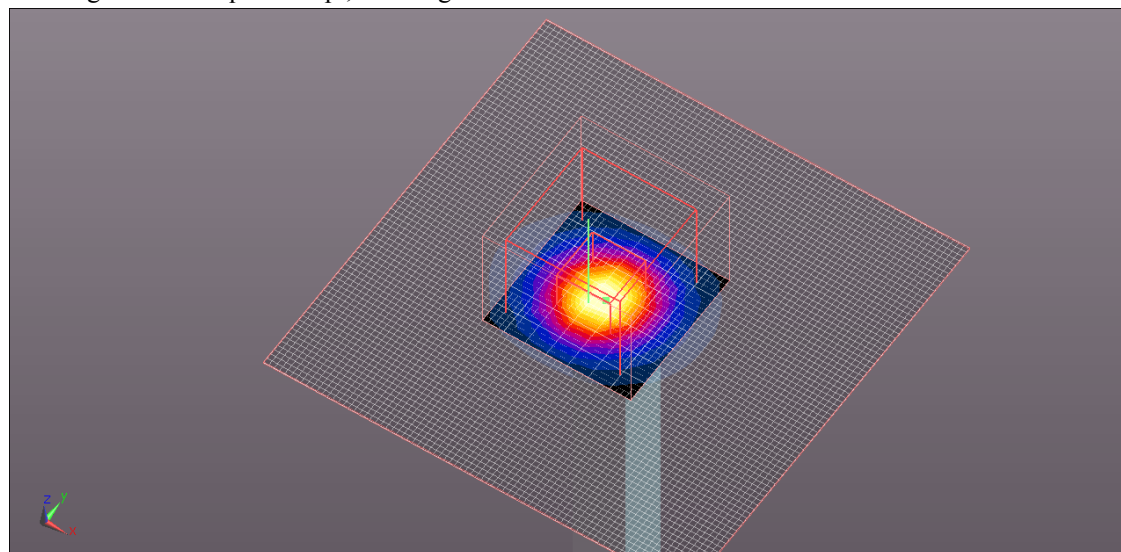
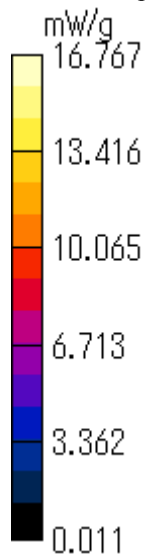

Body 5800MHz System Validation DATA / Dipole5GHz / Forward Conducted Power : 100mW

Communication System: WLAN 11a/b/g/n ; Communication System Band: 11a/n; Frequency: 5800 MHz;Duty Cycle: 1:1

Medium parameters used: $f = 5800$ MHz; $\sigma = 6.29$ mho/m; $\epsilon_r = 45.9$; $\rho = 1000$ kg/m³

Phantom section: Flat Section

Measurement Standard: DASYS (IEEE/IEC/ANSI C63.19-2007)

DASY5 Configuration

Probe: EX3DV4 - SN3540; ConvF(3.4, 3.4, 3.4); Calibrated: 2011/07/21

Sensor-Surface: 2mm (Mechanical Surface Detection)

Electronics: DAE4 Sn509; Calibrated: 2011/07/20

Phantom: ELI 4.0; Type: QDOVA001BA;

Measurement SW: DASYS2, Version 52.6 (1);

Area Scan (61x61x1): Measurement grid: dx=10mm, dy=10mm

Maximum value of SAR (interpolated) = 17.090 mW/g

Zoom Scan (8x8x10)/Cube 0: Measurement grid: dx=4mm, dy=4mm, dz=2.5mm

Reference Value = 1.645 V/m; Power Drift = 0.06 dB

Peak SAR (extrapolated) = 32.780 W/kg

SAR(1 g) = 8.13 mW/g; SAR(10 g) = 2.25 mW/g

Maximum value of SAR (measured) = 16.394 mW/g

Date: 2011/11/06

Ambient Temp. : 24.6 degree.C. Liquid Temp.; 24.2 degree.C.

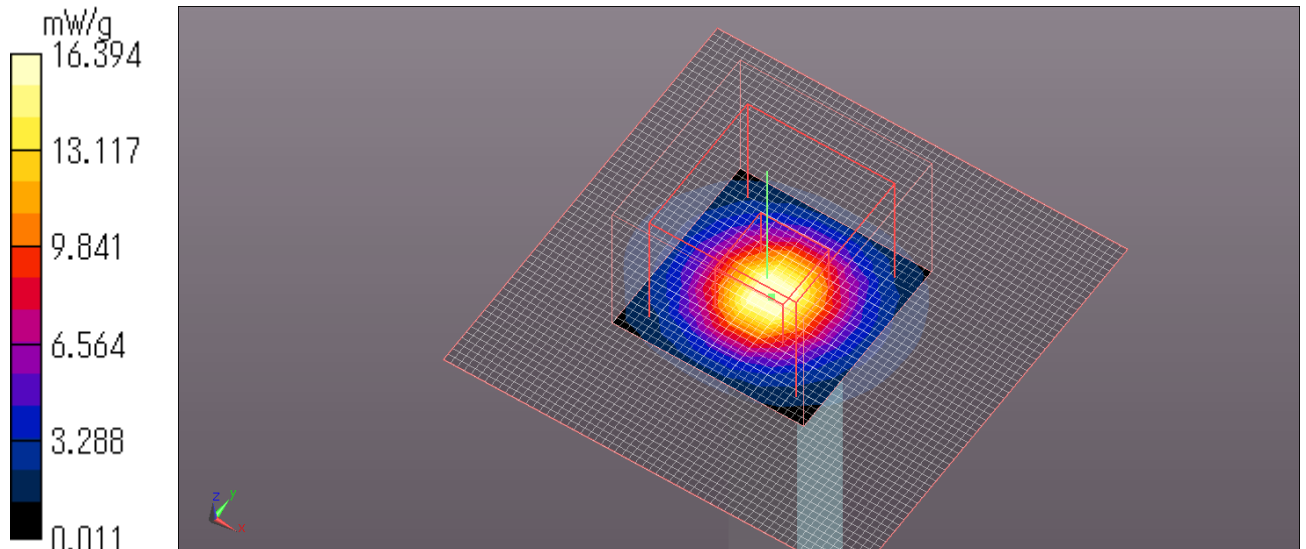

5. System Validation Dipole (D5GHzV2,S/N:1020)

Calibration Laboratory of
Schmid & Partner
Engineering AG
Zeughausstrasse 43, 8004 Zurich, Switzerland



S Schweizerischer Kalibrierdienst
C Service suisse d'étalonnage
S Servizio svizzero di taratura
S Swiss Calibration Service

Accredited by the Swiss Accreditation Service (SAS)
The Swiss Accreditation Service is one of the signatories to the EA
Multilateral Agreement for the recognition of calibration certificates

Accreditation No.: SCS 108

Client **UL Japan (PTT)**

Certificate No: **D5GHz-1020_Aug11**

CALIBRATION CERTIFICATE

Object: **D5GHzV2 - SN: 1020**

Calibration procedure(s): **QA CAL-22.v1
Calibration procedure for dipole validation kits between 3-6 GHz**

Calibration date: **August 23, 2011**

This calibration certificate documents the traceability to national standards, which realize the physical units of measurements (SI).
The measurements and the uncertainties with confidence probability are given on the following pages and are part of the certificate.

All calibrations have been conducted in the closed laboratory facility: environment temperature (22 ± 3)°C and humidity < 70%.

Calibration Equipment used (M&TE critical for calibration)

Primary Standards	ID #	Cal Date (Certificate No.)	Scheduled Calibration
Power meter EPM-442A	GB37480704	06-Oct-10 (No. 217-01266)	Oct-11
Power sensor HP 8481A	US37292783	06-Oct-10 (No. 217-01266)	Oct-11
Reference 20 dB Attenuator	SN: 5086 (20g)	29-Mar-11 (No. 217-01368)	Apr-12
Type-N mismatch combination	SN: 5047.2 / 06327	29-Mar-11 (No. 217-01371)	Apr-12
Reference Probe EX3DV4	SN: 3503	04-Mar-11 (No. EX3-3503_Mar11)	Mar-12
DAE4	SN: 601	04-Jul-11 (No. DAE4-601_Jul11)	Jul-12
Secondary Standards	ID #	Check Date (in house)	Scheduled Check
Power sensor HP 8481A	MY41092317	18-Oct-02 (in house check Oct-09)	In house check: Oct-11
RF generator R&S SMT-06	100005	04-Aug-99 (in house check Oct-09)	In house check: Oct-11
Network Analyzer HP 8753E	US37390585 S4206	18-Oct-01 (in house check Oct-10)	In house check: Oct-11

Calibrated by: **Claudio Leubler** (Name), **Laboratory Technician** (Function), *[Signature]* (Signature)

Approved by: **Katja Pokovic** (Name), **Technical Manager** (Function), *[Signature]* (Signature)

Issued: August 23, 2011

This calibration certificate shall not be reproduced except in full without written approval of the laboratory.

**Calibration Laboratory of
Schmid & Partner
Engineering AG**
Zeughausstrasse 43, 8004 Zurich, Switzerland



S Schweizerischer Kalibrierdienst
C Service suisse d'étalonnage
S Servizio svizzero di taratura
S Swiss Calibration Service

Accredited by the Swiss Accreditation Service (SAS)
The Swiss Accreditation Service is one of the signatories to the EA
Multilateral Agreement for the recognition of calibration certificates

Accreditation No.: **SCS 108**

Glossary:

TSL tissue simulating liquid
ConvF sensitivity in TSL / NORM x,y,z
N/A not applicable or not measured

Calibration is Performed According to the Following Standards:

- a) IEEE Std 1528-2003, "IEEE Recommended Practice for Determining the Peak Spatial-Averaged Specific Absorption Rate (SAR) in the Human Head from Wireless Communications Devices: Measurement Techniques", December 2003
- b) IEC 62209-1, "Procedure to measure the Specific Absorption Rate (SAR) for hand-held devices used in close proximity to the ear (frequency range of 300 MHz to 3 GHz)", February 2005
- c) Federal Communications Commission Office of Engineering & Technology (FCC OET), "Evaluating Compliance with FCC Guidelines for Human Exposure to Radiofrequency Electromagnetic Fields; Additional Information for Evaluating Compliance of Mobile and Portable Devices with FCC Limits for Human Exposure to Radiofrequency Emissions", Supplement C (Edition 01-01) to Bulletin 65

Additional Documentation:

- d) DASY4/5 System Handbook

Methods Applied and Interpretation of Parameters:

- *Measurement Conditions:* Further details are available from the Validation Report at the end of the certificate. All figures stated in the certificate are valid at the frequency indicated.
- *Antenna Parameters with TSL:* The dipole is mounted with the spacer to position its feed point exactly below the center marking of the flat phantom section, with the arms oriented parallel to the body axis.
- *Feed Point Impedance and Return Loss:* These parameters are measured with the dipole positioned under the liquid filled phantom. The impedance stated is transformed from the measurement at the SMA connector to the feed point. The Return Loss ensures low reflected power. No uncertainty required.
- *Electrical Delay:* One-way delay between the SMA connector and the antenna feed point. No uncertainty required.
- *SAR measured:* SAR measured at the stated antenna input power.
- *SAR normalized:* SAR as measured, normalized to an input power of 1 W at the antenna connector.
- *SAR for nominal TSL parameters:* The measured TSL parameters are used to calculate the nominal SAR result.

UL Japan, Inc.

Head Office EMC Lab.

4383-326 Asama-cho, Ise-shi, Mie-ken 516-0021 JAPAN

Telephone: +81 596 24 8116

Facsimile: +81 596 24 8124

Measurement Conditions

DASY system configuration, as far as not given on page 1.

DASY Version	DASY5	V52.6.2
Extrapolation	Advanced Extrapolation	
Phantom	Modular Flat Phantom V5.0	
Distance Dipole Center - TSL	10 mm	with Spacer
Zoom Scan Resolution	dx, dy = 4.0 mm, dz = 1.4 mm	Graded Ratio = 1.4 (Z direction)
Frequency	5200 MHz ± 1 MHz 5500 MHz ± 1 MHz 5800 MHz ± 1 MHz	

Head TSL parameters at 5200 MHz

The following parameters and calculations were applied.

	Temperature	Permittivity	Conductivity
Nominal Head TSL parameters	22.0 °C	36.0	4.66 mho/m
Measured Head TSL parameters	(22.0 ± 0.2) °C	35.7 ± 6 %	4.49 mho/m ± 6 %
Head TSL temperature change during test	< 0.5 °C	----	----

SAR result with Head TSL at 5200 MHz

SAR averaged over 1 cm ³ (1 g) of Head TSL	Condition	
SAR measured	100 mW input power	7.59 mW / g
SAR for nominal Head TSL parameters	normalized to 1W	75.7 mW / g ± 17.0 % (k=2)

SAR averaged over 10 cm ³ (10 g) of Head TSL	condition	
SAR measured	100 mW input power	2.16 mW / g
SAR for nominal Head TSL parameters	normalized to 1W	21.5 mW / g ± 16.5 % (k=2)

Head TSL parameters at 5500 MHz

The following parameters and calculations were applied.

	Temperature	Permittivity	Conductivity
Nominal Head TSL parameters	22.0 °C	35.6	4.96 mho/m
Measured Head TSL parameters	(22.0 ± 0.2) °C	35.3 ± 6 %	4.79 mho/m ± 6 %
Head TSL temperature change during test	< 0.5 °C	----	----

SAR result with Head TSL at 5500 MHz

SAR averaged over 1 cm ³ (1 g) of Head TSL	Condition	
SAR measured	100 mW input power	7.91 mW / g
SAR for nominal Head TSL parameters	normalized to 1W	78.9 mW / g ± 17.0 % (k=2)

SAR averaged over 10 cm ³ (10 g) of Head TSL	condition	
SAR measured	100 mW input power	2.24 mW / g
SAR for nominal Head TSL parameters	normalized to 1W	22.3 mW / g ± 16.5 % (k=2)

Head TSL parameters at 5800 MHz

The following parameters and calculations were applied.

	Temperature	Permittivity	Conductivity
Nominal Head TSL parameters	22.0 °C	35.3	5.27 mho/m
Measured Head TSL parameters	(22.0 ± 0.2) °C	34.8 ± 6 %	5.09 mho/m ± 6 %
Head TSL temperature change during test	< 0.5 °C	----	----

SAR result with Head TSL at 5800 MHz

SAR averaged over 1 cm ³ (1 g) of Head TSL	Condition	
SAR measured	100 mW input power	7.31 mW / g
SAR for nominal Head TSL parameters	normalized to 1W	72.8 mW / g ± 17.0 % (k=2)

SAR averaged over 10 cm ³ (10 g) of Head TSL	condition	
SAR measured	100 mW input power	2.08 mW / g
SAR for nominal Head TSL parameters	normalized to 1W	20.7 mW / g ± 16.5 % (k=2)

Body TSL parameters at 5200 MHz

The following parameters and calculations were applied.

	Temperature	Permittivity	Conductivity
Nominal Body TSL parameters	22.0 °C	49.0	5.30 mho/m
Measured Body TSL parameters	(22.0 ± 0.2) °C	48.8 ± 6 %	5.45 mho/m ± 6 %
Body TSL temperature change during test	< 0.5 °C	----	----

SAR result with Body TSL at 5200 MHz

SAR averaged over 1 cm ³ (1 g) of Body TSL	Condition	
SAR measured	100 mW input power	7.52 mW / g
SAR for nominal Body TSL parameters	normalized to 1W	75.1 mW / g ± 18.1 % (k=2)

SAR averaged over 10 cm ³ (10 g) of Body TSL	condition	
SAR measured	100 mW input power	2.11 mW / g
SAR for nominal Body TSL parameters	normalized to 1W	21.1 mW / g ± 17.6 % (k=2)

Body TSL parameters at 5500 MHz

The following parameters and calculations were applied.

	Temperature	Permittivity	Conductivity
Nominal Body TSL parameters	22.0 °C	48.6	5.65 mho/m
Measured Body TSL parameters	(22.0 ± 0.2) °C	48.3 ± 6 %	5.86 mho/m ± 6 %
Body TSL temperature change during test	< 0.5 °C	----	----

SAR result with Body TSL at 5500 MHz

SAR averaged over 1 cm ³ (1 g) of Body TSL	Condition	
SAR measured	100 mW input power	8.00 mW / g
SAR for nominal Body TSL parameters	normalized to 1W	79.9 mW / g ± 18.1 % (k=2)

SAR averaged over 10 cm ³ (10 g) of Body TSL	condition	
SAR measured	100 mW input power	2.22 mW / g
SAR for nominal Body TSL parameters	normalized to 1W	22.2 mW / g ± 17.6 % (k=2)

Body TSL parameters at 5800 MHz

The following parameters and calculations were applied.

	Temperature	Permittivity	Conductivity
Nominal Body TSL parameters	22.0 °C	48.2	6.00 mho/m
Measured Body TSL parameters	(22.0 ± 0.2) °C	47.7 ± 6 %	6.27 mho/m ± 6 %
Body TSL temperature change during test	< 0.5 °C	----	----

SAR result with Body TSL at 5800 MHz

SAR averaged over 1 cm ³ (1 g) of Body TSL	Condition	
SAR measured	100 mW input power	7.45 mW / g
SAR for nominal Body TSL parameters	normalized to 1W	74.4 mW / g ± 18.1 % (k=2)

SAR averaged over 10 cm ³ (10 g) of Body TSL	condition	
SAR measured	100 mW input power	2.07 mW / g
SAR for nominal Body TSL parameters	normalized to 1W	20.7 mW / g ± 17.6 % (k=2)

Appendix**Antenna Parameters with Head TSL at 5200 MHz**

Impedance, transformed to feed point	48.8 Ω - 9.8 $\mu\Omega$
Return Loss	- 20.0 dB

Antenna Parameters with Head TSL at 5500 MHz

Impedance, transformed to feed point	49.3 Ω - 2.7 $\mu\Omega$
Return Loss	- 31.1 dB

Antenna Parameters with Head TSL at 5800 MHz

Impedance, transformed to feed point	55.4 Ω - 0.8 $\mu\Omega$
Return Loss	- 25.7 dB

Antenna Parameters with Body TSL at 5200 MHz

Impedance, transformed to feed point	49.2 Ω - 8.4 $\mu\Omega$
Return Loss	- 21.4 dB

Antenna Parameters with Body TSL at 5500 MHz

Impedance, transformed to feed point	49.7 Ω - 2.0 $\mu\Omega$
Return Loss	- 33.9 dB

Antenna Parameters with Body TSL at 5800 MHz

Impedance, transformed to feed point	56.6 Ω + 0.4 $\mu\Omega$
Return Loss	- 24.1 dB

General Antenna Parameters and Design

Electrical Delay (one direction)	1.199 ns
----------------------------------	----------

After long term use with 100W radiated power, only a slight warming of the dipole near the feedpoint can be measured.

The dipole is made of standard semirigid coaxial cable. The center conductor of the feeding line is directly connected to the second arm of the dipole. The antenna is therefore short-circuited for DC-signals.

No excessive force must be applied to the dipole arms, because they might bend or the soldered connections near the feedpoint may be damaged.

Additional EUT Data

Manufactured by	SPEAG
Manufactured on	February 05, 2004

DASY5 Validation Report for Head TSL

Date: 22.08.2011

Test Laboratory: SPEAG, Zurich, Switzerland

DUT: Dipole 5GHz; Type: D5GHz; Serial: D5GHzV2 - SN: 1020

Communication System: CW; Frequency: 5200 MHz, Frequency: 5500 MHz, Frequency: 5800 MHz

Medium parameters used: $f = 5200$ MHz; $\sigma = 4.49$ mho/m; $\epsilon_r = 35.7$; $\rho = 1000$ kg/m³,

Medium parameters used: $f = 5500$ MHz; $\sigma = 4.79$ mho/m; $\epsilon_r = 35.3$; $\rho = 1000$ kg/m³,

Medium parameters used: $f = 5800$ MHz; $\sigma = 5.09$ mho/m; $\epsilon_r = 34.8$; $\rho = 1000$ kg/m³

Phantom section: Flat Section

Measurement Standard: DASY5 (IEEE/IEC/ANSI C63.19-2007)

DASY52 Configuration:

- Probe: EX3DV4 - SN3503; ConvF(5.41, 5.41, 5.41), ConvF(4.91, 4.91, 4.91), ConvF(4.81, 4.81, 4.81); Calibrated: 04.03.2011
- Sensor-Surface: 1.4mm (Mechanical Surface Detection)
- Electronics: DAE4 Sn601; Calibrated: 04.07.2011
- Phantom: Flat Phantom 5.0 (front); Type: QD000P50AA; Serial: 1001
- DASY52 52.6.2(482); SEMCAD X 14.4.5(3634)

Dipole Calibration for Head Tissue/Pin=100mW, dist=10mm, f=5200 MHz/Zoom Scan,

dist=1.4mm (8x8x7)/Cube 0: Measurement grid: dx=4mm, dy=4mm, dz=1.4mm

Reference Value = 64.076 V/m; Power Drift = 0.07 dB

Peak SAR (extrapolated) = 28.396 W/kg

SAR(1 g) = 7.59 mW/g; SAR(10 g) = 2.16 mW/g

Maximum value of SAR (measured) = 17.283 mW/g

Dipole Calibration for Head Tissue/Pin=100mW, dist=10mm, f=5500 MHz/Zoom Scan,

dist=1.4mm (8x8x7)/Cube 0: Measurement grid: dx=4mm, dy=4mm, dz=1.4mm

Reference Value = 63.853 V/m; Power Drift = 0.02 dB

Peak SAR (extrapolated) = 31.592 W/kg

SAR(1 g) = 7.91 mW/g; SAR(10 g) = 2.24 mW/g

Maximum value of SAR (measured) = 18.499 mW/g

Dipole Calibration for Head Tissue/Pin=100mW, dist=10mm, f=5800 MHz/Zoom Scan,

dist=1.4mm (8x8x7)/Cube 0: Measurement grid: dx=4mm, dy=4mm, dz=1.4mm

Reference Value = 58.832 V/m; Power Drift = -0.04 dB

Peak SAR (extrapolated) = 30.526 W/kg

SAR(1 g) = 7.31 mW/g; SAR(10 g) = 2.08 mW/g

Maximum value of SAR (measured) = 17.712 mW/g

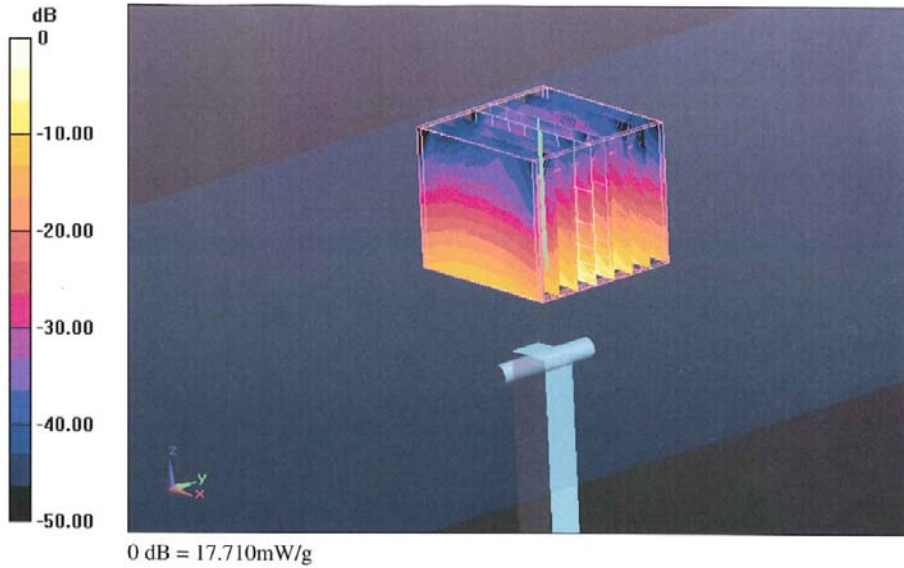

Impedance Measurement Plot for Head TSL

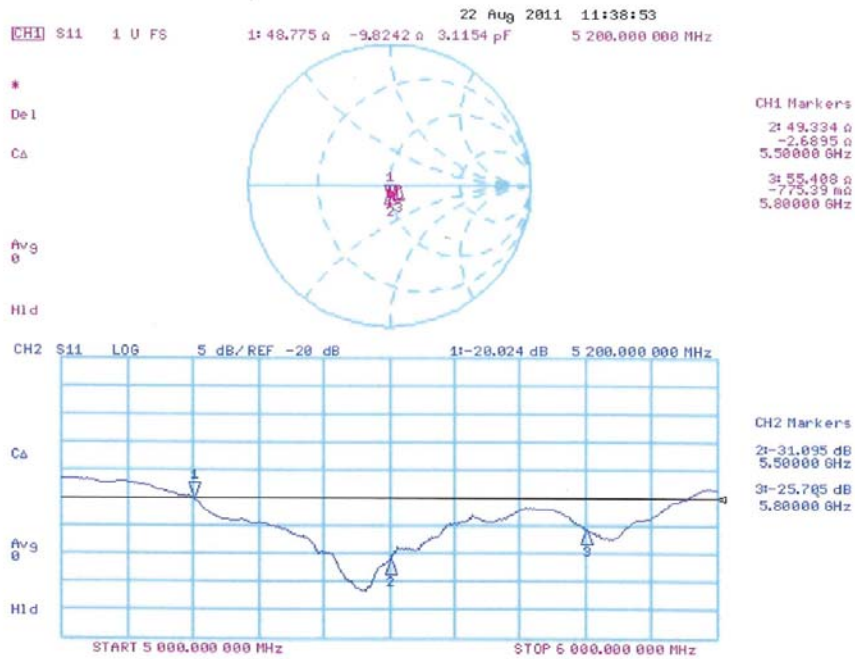

DASY5 Validation Report for Body TSL

Date: 23.08.2011

Test Laboratory: SPEAG, Zurich, Switzerland

DUT: Dipole 5GHz; Type: D5GHz; Serial: D5GHzV2 - SN: 1020

Communication System: CW; Frequency: 5200 MHz, Frequency: 5500 MHz, Frequency: 5800 MHz

Medium parameters used: $f = 5200$ MHz; $\sigma = 5.45$ mho/m; $\epsilon_r = 48.8$; $\rho = 1000$ kg/m³,

Medium parameters used: $f = 5500$ MHz; $\sigma = 5.86$ mho/m; $\epsilon_r = 48.3$; $\rho = 1000$ kg/m³,

Medium parameters used: $f = 5800$ MHz; $\sigma = 6.27$ mho/m; $\epsilon_r = 47.7$; $\rho = 1000$ kg/m³

Phantom section: Flat Section

Measurement Standard: DASY5 (IEEE/IEC/ANSI C63.19-2007)

DASY52 Configuration:

- Probe: EX3DV4 - SN3503; ConvF(4.91, 4.91, 4.91), ConvF(4.43, 4.43, 4.43), ConvF(4.38, 4.38, 4.38); Calibrated: 04.03.2011
- Sensor-Surface: 1.4mm (Mechanical Surface Detection)
- Electronics: DAE4 Sn601; Calibrated: 04.07.2011
- Phantom: Flat Phantom 5.0 (back); Type: QD000P50AA; Serial: 1002
- DASY52 52.6.2(482); SEMCAD X 14.4.5(3634)

Dipole Calibration for Body Tissue/Pin=100mW, dist=10mm, f=5200 MHz/Zoom Scan, dist=1.4mm (8x8x7)/Cube 0:

Measurement grid: dx=4mm, dy=4mm, dz=1.4mm

Reference Value = 58.047 V/m; Power Drift = 0.03 dB

Peak SAR (extrapolated) = 29.159 W/kg

SAR(1 g) = 7.52 mW/g; SAR(10 g) = 2.11 mW/g

Maximum value of SAR (measured) = 17.129 mW/g

Dipole Calibration for Body Tissue/Pin=100mW, dist=10mm, f=5500 MHz/Zoom Scan, dist=1.4mm (8x8x7)/Cube 0:

Measurement grid: dx=4mm, dy=4mm, dz=1.4mm

Reference Value = 58.219 V/m; Power Drift = 0.0032 dB

Peak SAR (extrapolated) = 33.950 W/kg

SAR(1 g) = 8 mW/g; SAR(10 g) = 2.22 mW/g

Maximum value of SAR (measured) = 18.840 mW/g

Dipole Calibration for Body Tissue/Pin=100mW, dist=10mm, f=5800 MHz/Zoom Scan, dist=1.4mm (8x8x7)/Cube 0:

Measurement grid: dx=4mm, dy=4mm, dz=1.4mm

Reference Value = 54.661 V/m; Power Drift = 0.03 dB

Peak SAR (extrapolated) = 34.226 W/kg

SAR(1 g) = 7.45 mW/g; SAR(10 g) = 2.07 mW/g

Maximum value of SAR (measured) = 18.095 mW/g

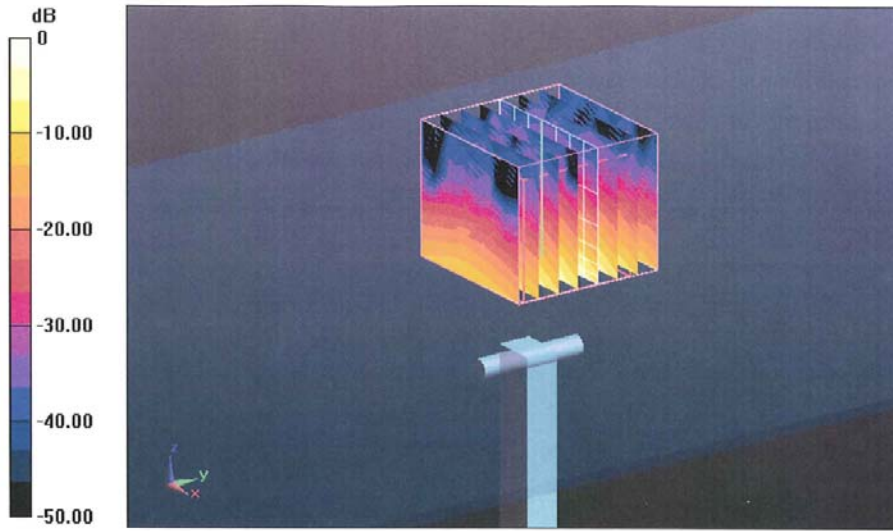

0 dB = 18.090mW/g

Impedance Measurement Plot for Body TSL

