



RADIO TEST REPORT

Test Report No. : 32BE0278-HO-N-R1

Applicant : SAMSUNG ELECTRONICS CO., LTD.
Type of Equipment : Cellular/PCS GSM/GPRS/EDGE, Cellular/PCS WCDMA Tablet with 802.11abgn, BT3.0
Model No. : GT-P6200L
Test standard : FCC Part 22 Subpart H: 2006
FCC ID : A3LGTP6200L
Test Result : Complied

1. This test report shall not be reproduced in full or partial, without the written approval of UL Japan, Inc.
2. The results in this report apply only to the sample tested.
3. This sample tested is in compliance with above regulation.
4. The test results in this report are traceable to the national or international standards.
5. This test report must not be used by the customer to claim product certification, approval, or endorsement by NVLAP, NIST, or any agency of the Federal Government.
6. This report is a revised version of 32BE0278-HO-N. 32BE0278-HO-N is replaced with this report.

Date of test: September 30 to October 8, 2011

Representative test engineer:

Yutaka Yoshida
Engineer of WiSE Japan,
UL Verification Service

Approved by:

Takahiro Hatakeda
Leader of WiSE Japan,
UL Verification Service



NVLAP LAB CODE: 200572-0

This laboratory is accredited by the NVLAP LAB CODE 200572-0, U.S.A. The tests reported herein have been performed in accordance with its terms of accreditation.
*As for the range of Accreditation in NVLAP, you may refer to the WEB address,
<http://www.ul.com/japan/jpn/pages/services/emc/about/mark1/index.jsp#nvlap>

UL Japan, Inc.

Head Office EMC Lab.

4383-326 Asama-cho, Ise-shi, Mie-ken 516-0021 JAPAN

Telephone : +81 596 24 8116

Facsimile : +81 596 24 8124

CONTENTS	PAGE
SECTION 1: Customer information	3
SECTION 2: Equipment under test (E.U.T.)	3
SECTION 3: Test specification, procedures & results	5
SECTION 4: Operation of E.U.T. during testing.....	8
SECTION 5: RF Output Power (Conducted/Radiated).....	14
SECTION 6: Bandwidth (Conducted)	15
SECTION 7: Spurious Emission and Band-Edge (Conducted/Radiated)	15
SECTION 8: Frequency Stability(Temperature/Voltage Variation).....	16
APPENDIX 1: Data of EMI test	17
RF Output Power (Conducted).....	17
RF Output Power (Radiated).....	19
Peak to Average power Ratio (Conducted)	21
Bandwidth(Conducted)	23
Spurious Emission (Conducted)	30
Spurious Emission (Radiated)	42
Frequency Stability(Temperature/Voltage Variation).....	45
APPENDIX 3: Test instruments	47
APPENDIX3: Photographs of test setup.....	49
Radiated Spurious Emission	49
Worst Case Position (Horizontal: X-axis/ Vertical:Y-axis)	50

SECTION 1: Customer information

Company Name : SAMSUNG ELECTRONICS CO., LTD.
Address : 416, MAETAN 3-DONG, YEONGTONG-GU SUWON-CITY,
GYEONGGI-DO 443-742, SOUTH KOREA

SECTION 2: Equipment under test (E.U.T.)

2.1 Identification of E.U.T.

Type of Equipment : Cellular/PCS GSM/GPRS/EDGE, Cellular/PCS WCDMA Tablet with
802.11abgn, BT3.0
Model No. : GT-P6200L
Serial No. : Refer to Section 4, Clause 4.2
Rating : DC4.0V
Receipt Date of Sample : September 27, 2011
Modification of EUT : No Modification by the test lab

2.2 Product Description

Radio Specification

Bluetooth

Equipment Type	Transceiver
Frequency of Operation	2402-2480MHz
Type of Modulation	FHSS
Bandwidth & Channel spacing	1MHz & 1MHz
Antenna Type	PIFA
Antenna Gain	-0.63 dBi

WLAN (IEEE802.11a/b/g/n-20)

Equipment Type	Transceiver	
Frequency of Operation	2412-2462MHz	5180-5240MHz 5260-5320MHz 5500-5700MHz 5745-5825MHz
Type of Modulation	DSSS, OFDM	OFDM
Bandwidth & Channel spacing	20MHz & 5MHz	20MHz & 20MHz
Antenna Type	SEMI-PIFA	
Antenna Gain	2.4G: -2.85dBi	5G: -4.15dBi

WLAN (IEEE802.11n-40)

Equipment Type	Transceiver
Frequency of Operation	5190-5230MHz 5270-5310MHz 5510-5670MHz 5755-5795MHz
Type of Modulation	OFDM
Bandwidth & Channel spacing	40MHz & 40MHz
Antenna Type	SEMI-PIFA
Antenna Gain	-4.15dBi

UL Japan, Inc.

Head Office EMC Lab.

4383-326 Asama-cho, Ise-shi, Mie-ken 516-0021 JAPAN

Telephone : +81 596 24 8116

Facsimile : +81 596 24 8124

GSM

Equipment Type	Transceiver
Frequency of Operation	[Up Link] GSM850: 824 – 849MHz PCS: 1850 – 1910MHz [Down Link] GSM850: 869 – 894MHz PCS: 1930 – 1990MHz
Type of Modulation	GMSK , 8PSK
Emission Designator	GSM850: 248KGXW, 248KG7W PCS: 254KGXW, 250KG7W
Antenna Type	PIFA
Antenna Gain	GSM850: -5.86dBi PCS: -4.02dBi

W-CDMA

Equipment Type	Transceiver
Frequency of Operation	[Up Link] Band V: 824 – 849MHz Band II: 1850 – 1910MHz [Down Link] Band V: 869 – 894MHz Band II: 1930 – 1990MHz
Type of Modulation	QPSK
Emission Designator	Band V: 4M05F9W Band II: 4M06F9W
Antenna Type	PIFA
Antenna Gain	Band V: -5.86dBi Band II: -4.02dBi

SECTION 3: Test specification, procedures & results

3.1 Test Specification

Test Specification : FCC Part 22 Subpart H: 2006, final revised on November 29, 2006
Title : FCC 47CFR Part 22 Subpart H
Cellular Radiotelephone Service

3.2 Procedures and results

Item	Test Specification & Procedure	Remarks	Deviation	Worst margin	Results
RF Output Power(Conducted/ Radiated) (Conducted Output Power / Effective radiated power(ERP))	FCC 2.1046 FCC 22.913(a)(2)	Conducted/ Radiated	N/A	-	Complied
Emission Bandwidth, 99% Occupied Bandwidth	FCC 2.1049 FCC 22.917	Conducted	N/A	-	Complied
Band-Edge	FCC 2.1051 FCC 2.1053 FCC 22.917	Conducted/ Radiated	N/A	GSM [Conducted] 2.58dB 849.0185MHz [Radiated] 7.8dB 849.02MHz, Horizontal W-CDMA [Conducted] 6.28dB 823.9170MHz [Radiated] 10.1dB 824.00MHz, Horizontal	Complied
Spurious Emission(Conducted)	FCC 2.1051 FCC 22.917	Conducted	N/A	-	Complied
Spurious Emission(Radiated)	FCC 2.1053 FCC 22.917	Radiated	N/A	GSM 28.6dB 2472.60MHz, Horizontal W-CDMA 42.1dB 1693.20MHz, Vertical	Complied
Frequency Stability (Temperature Variation)	FCC 2.1055(a)(1)(b) FCC 22.355	Conducted	N/A	-	Complied
Frequency Stability (Voltage Variation)	FCC 2.1055(d)(1)(2) FCC 22.355	Conducted	N/A	-	Complied

Note: UL Japan's EMI Work Procedures No. 13-EM-W0420

*These tests were also referred to ANSI/TIA 603-C-2004 "Land Mobile FM or PM Communications Equipment Measurement and Performance Standards."

*These tests were performed without any deviations from test procedure except for additions or exclusions.

UL Japan, Inc.

Head Office EMC Lab.

4383-326 Asama-cho, Ise-shi, Mie-ken 516-0021 JAPAN

Telephone : +81 596 24 8116

Facsimile : +81 596 24 8124

3.3 Uncertainty

EMI

The following uncertainties have been calculated to provide a confidence level of 95% using a coverage factor k=2.

Radiated Emission (EUT height: 0.8m) (±dB)	
Measurement Distance 3m	
30MHz-300MHz	5.4dB
300MHz-1000MHz	4.0dB
1GHz-12.75GHz	4.4dB

Power meter (±dB)	
Below 1GHz	Above 1GHz
1.0dB	1.0dB

Antenna terminal conducted emission and Power density (±dB)			Antenna terminal conducted emission (±dB)		Channel power (±dB)
Below 1GHz	1GHz-3GHz	3GHz-18GHz	18GHz-26.5GHz	26.5GHz-40GHz	
1.0dB	1.1dB	2.7dB	3.2dB	3.3dB	1.5dB

Antenna Terminal Conducted emission test

The data listed in this test report has enough margin, more than the site margin.

Radiated emission test(3m)

The data listed in this report meets the limits unless the uncertainty is taken into consideration.

UL Japan, Inc.

Head Office EMC Lab.

4383-326 Asama-cho, Ise-shi, Mie-ken 516-0021 JAPAN

Telephone : +81 596 24 8116

Facsimile : +81 596 24 8124

3.4 Test Location

UL Japan, Inc. Head Office EMC Lab. *NVLAP Lab. code: 200572-0
4383-326 Asama-cho, Ise-shi, Mie-ken 516-0021 JAPAN
Telephone : +81 596 24 8116 Facsimile : +81 596 24 8124

	FCC Registration Number	IC Registration Number	Width x Depth x Height (m)	Size of reference ground plane (m) / horizontal conducting plane	Other rooms
No.1 semi-anechoic chamber	313583	2973C-1	19.2 x 11.2 x 7.7m	7.0 x 6.0m	No.1 Power source room
No.2 semi-anechoic chamber	655103	2973C-2	7.5 x 5.8 x 5.2m	4.0 x 4.0m	-
No.3 semi-anechoic chamber	148738	2973C-3	12.0 x 8.5 x 5.9m	6.8 x 5.75m	No.3 Preparation room
No.3 shielded room	-	-	4.0 x 6.0 x 2.7m	N/A	-
No.4 semi-anechoic chamber	134570	2973C-4	12.0 x 8.5 x 5.9m	6.8 x 5.75m	No.4 Preparation room
No.4 shielded room	-	-	4.0 x 6.0 x 2.7m	N/A	-
No.5 semi-anechoic chamber	-	-	6.0 x 6.0 x 3.9m	6.0 x 6.0m	-
No.6 shielded room	-	-	4.0 x 4.5 x 2.7m	4.75 x 5.4 m	-
No.6 measurement room	-	-	4.75 x 5.4 x 3.0m	4.75 x 4.15 m	-
No.7 shielded room	-	-	4.7 x 7.5 x 2.7m	4.7 x 7.5m	-
No.8 measurement room	-	-	3.1 x 5.0 x 2.7m	N/A	-
No.9 measurement room	-	-	8.0 x 4.5 x 2.8m	2.0 x 2.0m	-
No.10 measurement room	-	-	2.6 x 2.8 x 2.5m	2.4 x 2.4m	-
No.11 measurement room	-	-	3.1 x 3.4 x 3.0m	2.4 x 3.4m	-

* Size of vertical conducting plane (for Conducted Emission test): 2.0 x 2.0m for No.1, No.2, No.3, and No.4 semi-anechoic chambers and No.3 and No.4 shielded rooms.

3.5 Test set up, Test instruments and Data of EMI

Refer to APPENDIX.

SECTION 4: Operation of E.U.T. during testing

4.1 Operating Modes

<GSM850>

Test	Operating mode	Power Control	Tested frequency	Channel
RF output Power(Conducted), Peak to Average power Ratio (Conducted)	Transmitting (Tx) (GSM, GMSK, 1slot) Transmitting (Tx) (GPRS, GMSK, 1slot, CS-1) Transmitting (Tx) (EGPRS, 8PSK, 1slot, MCS-5)	Max (PCL=5)	824.2MHz 836.6MHz 848.8MHz	128 190 251
RF output Power (Radiated)	Transmitting (Tx) (GSM, GMSK, 1slot) Transmitting (Tx) (EGPRS, 8PSK, 1slot, MCS-5)	Max (PCL=5)	824.2MHz 836.6MHz 848.8MHz	128 190 251
Emission Bandwidth, 99% Occupied bandwidth	Transmitting (Tx) (GSM, GMSK, 1slot) Transmitting (Tx) (EGPRS, 8PSK, 1slot, MCS-5)	Max (PCL=5)	836.6MHz	190
Band Edge (Conducted)	Transmitting (Tx) (GSM, GMSK, 1slot) Transmitting (Tx) (EGPRS, 8PSK, 1slot, MCS-5)	Max (PCL=5)	824.2MHz 848.8MHz	128 251
Band Edge (Radiated)	Transmitting (Tx) (GSM, GMSK, 1slot)	Max (PCL=5)	824.2MHz 848.8MHz	128 251
Spurious Emission (Conducted)	Transmitting (Tx) (GSM, GMSK, 1slot) Transmitting (Tx) (EGPRS, 8PSK, 1slot, MCS-5)	Max (PCL=5)	824.2MHz 836.6MHz 848.8MHz	128 190 251
Spurious Emission (Radiated)	Transmitting (Tx) (GSM, GMSK, 1slot)	Max (PCL=5)	824.2MHz 848.8MHz	128 251
Frequency Stability (Temperature/Voltage Variation)	Transmitting (Tx) (GSM, GMSK, 1slot)	Max (PCL=5)	836.6MHz	190

<W-CDMA Band V>

Test	Operating mode	Power Control	Tested frequency	Channel
RF output Power(Conducted)	Transmitting (Tx) W-CDMA (RMC12.2kbps) Transmitting (Tx) W-CDMA (AMR) Transmitting (Tx) W-CDMA (HSDPA Subtest 1-4) Transmitting (Tx) W-CDMA (HSUPA Subtest 1-5)	See Section 4.1.1	826.4MHz 836.6MHz 846.6MHz	4132 4183 4233
RF output Power (Radiated), Spurious Emission(Conducted/Radiated), Peak to Average power Ratio (Conducted)	Transmitting (Tx) W-CDMA (RMC12.2kbps)	TPC all up bits (MAX)	826.4MHz 836.6MHz 846.6MHz	4132 4183 4233
Band Edge (Conducted/Radiated)	Transmitting (Tx) W-CDMA (RMC12.2kbps)	TPC all up bits(MAX)	826.4MHz 846.6MHz	4132 4233
Emission Bandwidth, 99% Occupied bandwidth, Frequency Stability (Temperature/Voltage Variation)	Transmitting (Tx) W-CDMA (RMC12.2kbps)	TPC all up bits (MAX)	836.6MHz	4183

*The WCDMA and HSPA modes of EUT were verified on each channel and "sub-tests" according to section 4.1.1.
(Also refer to Release-6 procedures in section 5.2 of 3GPP TS 34.121.)

UL Japan, Inc.

Head Office EMC Lab.

4383-326 Asama-cho, Ise-shi, Mie-ken 516-0021 JAPAN

Telephone : +81 596 24 8116

Facsimile : +81 596 24 8124

4.1.1 Explanation of the Rel-99 WCDMA and Rel-6 HSPA measurement mode

3GPP defines UE Test Modes and Channel Configurations for Regulatory Testing.

- **UE Test Modes:**
Test Mode 1(Data Loopback Test)
- **Channel Configurations:**
R99 – 12.2kpbs Reference Measurement Channel (RMC) channel
HSDPA – Fixed Reference Channel (FRC)
HSUPA – New HSUPA channel configuration (HSDPA data from DL is looped back onto UL)
- **Procedure to configure UE to transmit maximum power:**
Rel99: 3GPP TS 34.121 section 5.2
HSDPA Rel5: 3GPP TS 34.121 section 5.2A
HSDPA Rel6: 3GPP TS 34.121 section 5.2AA
HSUPA Rel6: 3GPP TS 34.121 section 5.2B

* About Rel-99 and HSDPA testing, test equipment send “all up bits” forcing UE max power

1) Explanation for HSDPA/HSPA Subtests

3GPP TS 34.121 defines test requirements and procedures for testing all variations of WCDMA. 3GPP TS 34.121 defines 4 HSDPA test configurations and 5 HSPA test configurations (“Subtests”) for various RF Conformance tests. The Following table shows Release 5 HSDPA and Release 6 HSPA Subtest Configurations per 3GPP TS 34.121.

[HSDPA]

Table C.10.1.4: β values for transmitter characteristics tests with HS-DPCCH

Sub-test	β_c	β_d	β_d (SF)	β_c/β_d	β_{HS} (Note 1, Note 2)	CM (dB) (Note 3)	MPR (dB) (Note 3)
1	2/15	15/15	64	2/15	4/15	0.0	0.0
2	12/15 (Note 4)	15/15 (Note 4)	64	12/15 (Note 4)	24/15	1.0	0.0
3	15/15	8/15	64	15/8	30/15	1.5	0.5
4	15/15	4/15	64	15/4	30/15	1.5	0.5

Note 1: Δ_{ACK} , Δ_{NACK} and $\Delta_{CQI} = 30/15$ with $\beta_{BS} = 30/15 * \beta_c$.

Note 2: For the HS-DPCCH power mask requirement test in clause 5.2C, 5.7A, and the Error Vector Magnitude (EVM) with HS-DPCCH test in clause 5.13.1A, and HSDPA EVM with phase discontinuity in clause 5.13.1AA, Δ_{ACK} and $\Delta_{NACK} = 30/15$ with $\beta_{BS} = 30/15 * \beta_c$, and $\Delta_{CQI} = 24/15$ with $\beta_{BS} = 24/15 * \beta_c$.

Note 3: CM = 1 for $\beta_c/\beta_d = 12/15$, $\beta_{HS}/\beta_c = 24/15$. For all other combinations of DPDCCH, DPCCH and HS-DPCCH the MPR is based on the relative CM difference. This is applicable for only UEs that support HSDPA in release 6 and later releases.

Note 4: For subtest 2 the β_c/β_d ratio of 12/15 for the TFC during the measurement period (TF1, TF0) is achieved by setting the signalled gain factors for the reference TFC (TF1, TF1) to $\beta_c = 11/15$ and $\beta_d = 15/15$.

UL Japan, Inc.

Head Office EMC Lab.

4383-326 Asama-cho, Ise-shi, Mie-ken 516-0021 JAPAN

Telephone : +81 596 24 8116

Facsimile : +81 596 24 8124

[HSUPA]

Table C.11.1.3: β values for transmitter characteristics tests with HS-DPCCH and E-DCH

Sub-test	β_c	β_d	β_d (SF)	β_c/β_d	β_{HS} (Note1)	β_{oc}	β_{ed} (Note 5) (Note 6)	β_{ed} (SF)	β_{ed} (Codes)	CM (dB) (Note 2)	MPR (dB) (Note 2)	AG Index (Note 6)	E- TFCI
1	11/15 (Note 3)	15/15 (Note 3)	64	11/15 (Note 3)	22/15	209/25	1309/225	4	1	1.0	0.0	20	75
2	6/15	15/15	64	6/15	12/15	12/15	94/75	4	1	3.0	2.0	12	67
3	15/15	9/15	64	15/9	30/15	30/15	$\beta_{ed1}: 47/15$ $\beta_{ed2}: 47/15$	4	2	2.0	1.0	15	92
4	2/15	15/15	64	2/15	4/15	2/15	56/75	4	1	3.0	2.0	17	71
5	15/15 (Note 4)	15/15 (Note 4)	64	15/15 (Note 4)	30/15	24/15	134/15	4	1	1.0	0.0	21	81

Note 1: Δ_{ACK} , Δ_{NACK} and $\Delta_{CQI} = 30/15$ with $\beta_{hs} = 30/15 * \beta_c$.

Note 2: CM = 1 for $\beta_c/\beta_d = 12/15$, $\beta_{hs}/\beta_c = 24/15$. For all other combinations of DPDCH, DPCCH, HS-DPCCH, E-DPDCH and E-DPCCH the MPR is based on the relative CM difference.

Note 3: For subtest 1 the β_c/β_d ratio of 11/15 for the TFC during the measurement period (TF1, TF0) is achieved by setting the signalled gain factors for the reference TFC (TF1, TF1) to $\beta_c = 10/15$ and $\beta_d = 15/15$.

Note 4: For subtest 5 the β_c/β_d ratio of 15/15 for the TFC during the measurement period (TF1, TF0) is achieved by setting the signalled gain factors for the reference TFC (TF1, TF1) to $\beta_c = 14/15$ and $\beta_d = 15/15$.

Note 5: In case of testing by UE using E-DPDCH Physical Layer category 1, Sub-test 3 is omitted according to TS25.306 Table 5.1g.

Note 6: β_d can not be set directly, it is set by Absolute Grant Value.

2) Maximum Output Power Verification

[HSDPA]

Maximum output power was verified on High, Middle and Low channels according to the Release 5 procedures described in section 5.2 of 3GPP TS 34.121, using an FRC with H-set 1 and 12.2kbps RMC with TPC (transmit power control) set to all "1's". Output power was measured according requirements for HS-DPCCH Sub-test 1-4.

[HSUPA]

Maximum output power was verified on the High, Middle and Low channels according to Release 6 procedures in section 5.2 of 3GPP TS 34.121, using the appropriate RMC, FRC and E-DCH configurations. When E-DCH was active, inner loop power control with power control algorithm 2 was used to maintain E-TFCI requirements. Output power for the applicable HSPA modes was measured for E-DCH Sub-test 1-5.

UL Japan, Inc.

Head Office EMC Lab.

4383-326 Asama-cho, Ise-shi, Mie-ken 516-0021 JAPAN

Telephone : +81 596 24 8116

Facsimile : +81 596 24 8124

3) Test Equipment Setting Summary Table

The following table is the key parameters that was configured in test equipment.

Subtest	Mode	Loopback Mode	Rel99 RMC	HSDPA FRC	HSUPA Test	Common Setting		β_c/β_d	MPR	Power Class 3 limit
						β_c	β_d			
	Rel99	Test Mode 1	12.2kbps RMC	-	-	-	-	8/15	-	24(+1.7/-3.7dB)
1	Rel6 HSDPA	Test Mode 1	12.2kbps RMC	H-Set 1 (QPSK)	-	2/15	15/15	2/15	0	24(+1.7/-3.7dB)
2	Rel6 HSDPA	Test Mode 1	12.2kbps RMC	H-Set 1 (QPSK)	-	12/15	15/15	12/15	0	24(+1.7/-3.7dB)
3	Rel6 HSDPA	Test Mode 1	12.2kbps RMC	H-Set 1 (QPSK)	-	15/15	8/15	15/8	0.5	23.5(+2.2/-3.7dB)
4	Rel6 HSDPA	Test Mode 1	12.2kbps RMC	H-Set 1 (QPSK)	-	15/15	4/15	15/4	0.5	23.5(+2.2/-3.7dB)
1	Rel6 HSUPA	Test Mode 1	12.2kbps RMC	H-Set 1 (QPSK)	HSUPA Loopback	11/15	15/15	11/15	0	24(+1.7/-3.7dB)
2	Rel6 HSUPA	Test Mode 1	12.2kbps RMC	H-Set 1 (QPSK)	HSUPA Loopback	6/15	15/15	6/15	2	22(+3.7/-3.7dB)
3	Rel6 HSUPA	Test Mode 1	12.2kbps RMC	H-Set 1 (QPSK)	HSUPA Loopback	15/15	9/15	15/9	1	23(+2.7/-3.7dB)
4	Rel6 HSUPA	Test Mode 1	12.2kbps RMC	H-Set 1 (QPSK)	HSUPA Loopback	2/15	15/15	2/15	2	22(+3.7/-3.7dB)
5	Rel6 HSUPA	Test Mode 1	12.2kbps RMC	H-Set 1 (QPSK)	HSUPA Loopback	15/15	15/15	15/15	0	24(+1.7/-3.7dB)

Subtest	HSDPA Specific Settings						
	Δ ACK	Δ NACK	Δ CQI	Ack-Nack repetition factor	CQI Feedback	CQI Repetition Factor	Ahs= β_{hs}/β_c
Rel 6 HSDPA							
1	8	8	8	3	4ms	2	30/15
2	8	8	8	3	4ms	2	30/15
3	8	8	8	3	4ms	2	30/15
4	8	8	8	3	4ms	2	30/15

Subtest	HSDPA Specific Settings							HSUPA Specific Settings			HSUPA Additional Info	
	Δ ACK	Δ NACK	Δ CQI	Ack-Nack repetition factor	CQI Feedback	CQI Repetition Factor	Ahs= β_{hs}/β_c	Δ E-DPCCH	Δ HARQ	AG Index	ETFCI (form TS34.121 Table C.11.1.3)	Associated Max UL Data Rate kbps
Rel 6 HSPA												
1	8	8	8	3	4ms	2	30/15	6	0	20	75	242.1
2	8	8	8	3	4ms	2	30/15	8	0	12	67	174.9
3	8	8	8	3	4ms	2	30/15	8	0	15	92	482.8
4	8	8	8	3	4ms	2	30/15	5	0	17	71	205.8
5	8	8	8	3	4ms	2	30/15	7	0	21	81	308.9

HSUPA Reference E-TFCI Parameters
 [Subtest 1,2,4,5]

Information Element	Value/Remark
E-DCH info	Uplink DPCH info
- E-DPDCH info	
- Reference E-TFCIs	5 E-TFCIs
- Reference E-TFCI	11
- Reference E-TFCI PO	4
- Reference E-TFCI	67
- Reference E-TFCI PO	18
- Reference E-TFCI	71
- Reference E-TFCI PO	23
- Reference E-TFCI	75
- Reference E-TFCI PO	26
- Reference E-TFCI	81
- Reference E-TFCI PO	27

[Subtest 3]

Information Element	Value/Remark
E-DCH info	Uplink DPCH info
- E-DPDCH info	
- Reference E-TFCIs	2 E-TFCIs
- Reference E-TFCI	11
- Reference E-TFCI PO	4
- Reference E-TFCI	92
- Reference E-TFCI PO	18

4.2 Configuration and peripherals

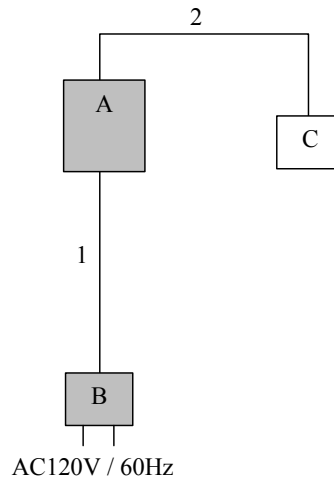

* Cabling and setup(s) were taken into consideration and test data was taken under worse case conditions.

Description of EUT and Support equipment

No.	Item	Model number	Serial number	Manufacturer	Remarks
A	Cellular/PCS GSM/GPRS/EDGE, Cellular/PCS WCDMA Tablet with 802.11abgn, BT3.0	GT-P6200L	R2DB815120W *1) R2DB815125K *2)	SAMSUNG	EUT
B	AC Adapter	ETA-P11X	-	SAMSUNG	EUT
C	Ear phone	-	-	SAMSUNG	-

*1) Used for Antenna Terminal Conducted test

*2) Used for Radiated Emission test

List of cables used

No.	Name	Length (m)	Shield		Remarks
			Cable	Connector	
1	USB Cable	1.0	Shielded	Shielded	-
2	Ear phone Cable	1.2	Unshielded	Unshielded	-

UL Japan, Inc.

Head Office EMC Lab.

4383-326 Asama-cho, Ise-shi, Mie-ken 516-0021 JAPAN

Telephone : +81 596 24 8116

Facsimile : +81 596 24 8124

SECTION 5: RF Output Power (Conducted/Radiated)

[Conducted: Conducted Output Power]

Test Procedure

The RF output power (conducted) was measured with Wireless Communication Test Set and an attenuator at the antenna port.

[Radiated : Effective radiated power(ERP)]

Test Procedure

- 1) EUT was placed on a platform of nominal size, 0.5 m by 1.0m, raised 80cm above the conducting ground plane. Test was made with the antenna positioned in both the horizontal and vertical planes of polarization. The Radiated Electric Field Strength intensity has been measured in a semi anechoic chamber with a ground plane and at a distance of 3m.
The measuring antenna height varied between 1 and 4m and EUT was rotated a full revolution in order to obtain the maximum value of the electric field intensity.
- 2) Exchanged the EUT to the Substitution Antenna, the antenna was set for the same height as EUT on the table. The frequency below 1GHz of the Substitution Antenna was used as the Half wave dipole Antenna, which is harmonized with the measured frequency in 1).
The Substitution Antenna was connected with the Signal Generator, and the polarized electromagnetic radiation of the Substitution Antenna was matched with the one of the measuring Antenna, which was set with the Signal Generator to the measured frequency in 1). Then, we set with the Output power (CW) of the Signal Generator where the measuring electromagnetic field is equal to the measured value in 1).
The measuring antenna height varied between 1 and 4m to obtain the maximum receiving level. Its Output power of Signal Generator was recorded.
- 3) Effective radiated power(ERP) was calculated by subtracting the cable loss and the attenuator loss connected between the Signal Generator and the Substitution Antenna from the Output power of the Signal Generator recorded in 2).

- The carrier level and noise levels were confirmed at each position of X, Y and Z axis of EUT to see the position of maximum noise, and the test was made at the position that has the maximum noise.

Test data : **APPENDIX 1**
Test result : **Pass**

SECTION 6: Bandwidth (Conducted)

Test Procedure

The Emission Bandwidth and 99% Occupied Bandwidth was measured with a spectrum analyzer and attenuator connected to the antenna port.

Test data : APPENDIX 1
Test result : Pass

SECTION 7: Spurious Emission and Band-Edge (Conducted/Radiated)

[Conducted]

Test Procedure

The Spurious Emission and Band-Edge was measured with a spectrum analyzer and attenuator connected to the antenna port.

[Radiated]

Test Procedure

- 1) EUT was placed on a platform of nominal size, 0.5m by 1.0m, raised 80cm above the conducting ground plane. Test was made with the antenna positioned in both the horizontal and vertical planes of polarization. The Radiated Electric Field Strength intensity has been measured in a semi anechoic chamber with a ground plane and at a distance of 3m. The measuring antenna height varied between 1 and 4m and EUT was rotated a full revolution in order to obtain the maximum value of the electric field intensity.
- 2) Exchanged the EUT to the Substitution Antenna, the antenna was set for the same height as EUT on the table. The frequency below 1GHz of the Substitution antenna was used as the Half wave dipole antenna and Shorted dipole antenna calibrated with the Half wave dipole antenna, which is harmonized with the measured frequency in 1). The frequency above 1GHz of the Substitution antenna was used with Horn antenna calibrated with the Half wave dipole antenna. The Substitution antenna was connected with the Signal Generator, and the polarized electromagnetic radiation of the Substitution antenna was matched with the one of the measuring antenna, which was set with the Signal Generator to the measured frequency in 1). Then, we set with the Output power (CW) of the Signal Generator where the measuring electromagnetic field is equal to the measured value in 1). The measuring antenna height varied between 1 and 4m to obtain the maximum receiving level. Its Output power of Signal Generator was recorded.
- 3) Effective radiated power was calculated by subtracting the cable loss and the attenuator loss connected between the Signal Generator and the Substitution Antenna from the Output power of the Signal Generator recorded in 2). For the usage of the antenna (Shorted dipole and Horn antenna) except for the Half wave dipole antenna (2.15dBi) for the Substitution antenna, the Effective radiated power was calculated by compensating the finite difference in the antenna gain of the Half wave dipole antenna, and Substitution antenna.

- The carrier level and noise levels were confirmed at each position of X, Y and Z axis of EUT to see the position of maximum noise, and the test was made at the position that has the maximum noise.

Test data : APPENDIX 1
Test result : Pass

UL Japan, Inc.

Head Office EMC Lab.

4383-326 Asama-cho, Ise-shi, Mie-ken 516-0021 JAPAN

Telephone : +81 596 24 8116

Facsimile : +81 596 24 8124

SECTION 8: Frequency Stability(Temperature/Voltage Variation)

Test Procedure

The Frequency Stability was measured with a Wireless Communication Test Set and attenuator connected to the antenna port.

The Frequency Drift was measured with the 10 deg. C. steps from -30 deg. C. to 50 deg. C., and it is presented as the ppm unit. The Frequency Drift was measured with the normal temperature (20 deg. C.) and Voltage tolerance (DC3.7V to DC4.2V), and it is presented as the ppm unit.

Temperature : -30deg.C to +50deg.C (10 deg. C. step)
Voltage : Vnom:DC4.0V, Vmin:DC3.7V, Vmax:DC4.2V

As the operating input voltage of the EUT is between DC3.7V to 4.2V (nominal voltage: DC4.0V), Frequency Stability test was performed under the above condition.

Test data : **APPENDIX 1**
Test result : **Pass**

APPENDIX 1: Data of EMI test

RF Output Power (Conducted)

Conducted Output Power GSM850

Test place Head Office EMC Lab. No.11 Measurement Room
Report No. 32BE0278-HO-N
Date 09/30/2011
Temperature/ Humidity 22deg.C / 52% RH
Engineer Yutaka Yoshida
Mode Tx GSM(GMSK), 1slot, PCL=5
Mode Tx GPRS(GMSK), 1slot, CS-1, PCL=5
Mode Tx EGPRS(8PSK), 1slot, MCS-5, PCL=5

Mode	Ch	Frequency [MHz]	Reading Average frame power [dBm]	Cable Loss [dB]	Result [dBm]
GSM	128	824.2	28.21	3.72	31.93
	190	836.6	28.11	3.72	31.83
	251	848.8	28.10	3.72	31.82
GPRS	128	824.2	28.21	3.72	31.93
	190	836.6	28.11	3.72	31.83
	251	848.8	28.09	3.72	31.81
EGPRS	128	824.2	22.85	3.72	26.57
	190	836.6	22.74	3.72	26.46
	251	848.8	22.70	3.72	26.42

Results = Reading + Cable Loss

RF Output Power (Conducted)

Conducted Output Power W-CDMA Band V

Test place	Head Office EMC Lab. No.7 Shielded Room
Report No.	32BE0278-HO-N
Date	09/30/2011
Temperature/ Humidity	22deg.C / 52% RH
Engineer	Yutaka Yoshida
Mode	Tx W-CDMA

Mode	Ch	Frequency [MHz]	Reading AVG [dBm]	Cable Loss [dB]	Result [dBm]
RMC 12.2kbps	Low	826.4	22.33	0.17	22.50
	Mid	836.6	22.30	0.17	22.47
	High	846.6	22.19	0.17	22.36
AMR	Low	826.4	22.31	0.17	22.48
	Mid	836.6	22.29	0.17	22.46
	High	846.6	22.19	0.17	22.36
HSDPA Subtest 1	Low	826.4	22.33	0.17	22.50
	Mid	836.6	22.28	0.17	22.45
	High	846.6	22.15	0.17	22.32
HSDPA Subtest 2	Low	826.4	22.06	0.17	22.23
	Mid	836.6	22.04	0.17	22.21
	High	846.6	21.90	0.17	22.07
HSDPA Subtest 3	Low	826.4	21.81	0.17	21.98
	Mid	836.6	21.76	0.17	21.93
	High	846.6	21.66	0.17	21.83
HSDPA Subtest 4	Low	826.4	21.55	0.17	21.72
	Mid	836.6	21.51	0.17	21.68
	High	846.6	21.40	0.17	21.57
HSUPA Subtest 1	Low	826.4	21.22	0.17	21.39
	Mid	836.6	21.31	0.17	21.48
	High	846.6	21.16	0.17	21.33
HSUPA Subtest 2	Low	826.4	19.95	0.17	20.12
	Mid	836.6	20.00	0.17	20.17
	High	846.6	19.89	0.17	20.06
HSUPA Subtest 3	Low	826.4	21.05	0.17	21.22
	Mid	836.6	21.05	0.17	21.22
	High	846.6	20.91	0.17	21.08
HSUPA Subtest 4	Low	826.4	20.54	0.17	20.71
	Mid	836.6	20.53	0.17	20.70
	High	846.6	20.39	0.17	20.56
HSUPA Subtest 5	Low	826.4	21.44	0.17	21.61
	Mid	836.6	21.42	0.17	21.59
	High	846.6	21.21	0.17	21.38

Results = Reading + Cable Loss

*The enhanced power reduction may result in around 1dB of variance from the MPR target values depending on HSPA channel configuration (e.g. 34.121 subtest) and characteristics of hardware RF design.

UL Japan, Inc.

Head Office EMC Lab.

4383-326 Asama-cho, Ise-shi, Mie-ken 516-0021 JAPAN

Telephone : +81 596 24 8116

Facsimile : +81 596 24 8124

RF Output Power (Radiated)
Effective radiated power(ERP)
GSM850

Report No. 32BE0278-HO-N
Test place Head Office EMC Lab. No.2 Semi Anechoic Chamber
Date 09/30/2011
Temperature / Humidity 20 deg. C / 67% RH
Engineer Keisuke Kawamura
Mode Tx GSM(GMSK), 1slot, PCL=5

Frequency [MHz]	Rx SA/TR Reading [dBuV]		Tx SG Reading [dBm]		Tx Cable Loss [dB]	Tx Ant. Gain [dBi]	Tx Ant. Atten. Loss [dB]	Result (ERP) [dBm]		Limit (ERP) [dBm]	Margin [dB]		Horizontal		Vertical		Remarks		
	HOR	VER	HOR	VER				HOR	VER		HOR	VER	HOR	VER	Rx Ant.	Turn		Rx Ant.	Turn
															Height	Table		Height	Table
824.20	94.9	90.3	40.3	39.6	5.6	2.2	10.0	24.7	24.0	38.4	13.7	14.4	100	107	100	124			
836.60	94.8	90.3	40.4	39.2	5.6	2.2	10.0	24.8	23.6	38.4	13.7	14.9	114	165	117	105			
848.80	96.1	90.9	42.8	40.1	5.7	2.2	10.1	27.1	24.4	38.4	11.3	14.0	110	156	116	106			

Calculation Result = SG Reading - Tx Cable Loss + Tx Antenna Gain - Tx Antenna Attenuator Loss -2.15
Rx-ANTENNA : Biconical Antenna(30M-300MHz), Logperiodic Antenna(300M-1000MHz), Horn Antenna(1G-12.75GHz)
Tx-ANTENNA : 120MHz tuned Dipole Antenna(30M-120MHz), Dipole Antenna(120M-1000MHz), Horn Antenna(1G-12.75GHz)
Other frequency noises omitted in this report were not seen or had enough margin (more than 20dB).
NS : No signal detect.
Detector : S/A PK (RBW: 3MHz, VBW: 8MHz)

Report No. 32BE0278-HO-N
Test place Head Office EMC Lab. No.4 Semi Anechoic Chamber
Date 10/14/2011
Temperature / Humidity 23deg. C / 69% RH
Engineer Katsunori Okai
Mode Tx EGPRS(8PSK), 1slot, MCS-5, PCL=5

Frequency [MHz]	Rx SA/TR Reading [dBuV]		Tx SG Reading [dBm]		Tx Cable Loss [dB]	Tx Ant. Gain [dBi]	Tx Ant. Atten. Loss [dB]	Result (ERP) [dBm]		Limit (ERP) [dBm]	Margin [dB]		Horizontal		Vertical		Remarks		
	HOR	VER	HOR	VER				HOR	VER		HOR	VER	HOR	VER	Rx Ant.	Turn		Rx Ant.	Turn
															Height	Table		Height	Table
824.20	89.6	87.1	36.7	36.9	4.7	2.2	10.0	22.0	22.2	38.4	16.4	16.2	115	146	111	80			
836.60	90.0	87.1	36.9	36.9	4.7	2.2	10.0	22.2	22.2	38.4	16.2	16.2	114	153	110	81			
848.80	90.7	88.0	39.0	38.7	4.7	2.2	10.1	24.2	23.9	39.4	15.2	15.5	114	160	110	91			

Calculation Result = SG Reading - Tx Cable Loss + Tx Antenna Gain - Tx Antenna Attenuator Loss -2.15
Rx-ANTENNA : Biconical Antenna(30M-300MHz), Logperiodic Antenna(300M-1000MHz), Horn Antenna(1G-12.75GHz)
Tx-ANTENNA : 120MHz tuned Dipole Antenna(30M-120MHz), Dipole Antenna(120M-1000MHz), Horn Antenna(1G-12.75GHz)
Other frequency noises omitted in this report were not seen or had enough margin (more than 20dB).
Detector : S/A PK (RBW: 3MHz, VBW: 8MHz)

RF Output Power (Radiated)

**Effective radiated power(ERP)
W-CDMA Band V**

Report No. 32BE0278-HO-N
Test place Head Office EMC Lab. No.2 Semi Anechoic Chamber
Date 10/05/2011
Temperature / Humidity 23deg. C / 57% RH
Engineer Takumi Shimada
Mode Tx W-CDMA(RMC12.2kbps), All Up Bits

Frequency [MHz]	Rx SA/TR Reading [dBuV]		Tx SG Reading [dBm]		Tx Cable Loss [dB]	Tx Ant. Gain [dBi]	Tx Ant. Atten. Loss [dB]	Result (ERP) [dBm]		Limit (ERP) [dBm]	Margin [dB]		Horizontal		Vertical		Remarks		
	HOR	VER	HOR	VER				HOR	VER		HOR	VER	HOR	VER	Rx Ant. Height [cm]	Turn Table [deg.]		Rx Ant. Height [cm]	Turn Table [deg.]
826.40	92.7	86.8	38.4	37.2	5.57	2.15	10.03	22.8	21.6	38.4	15.6	16.8	100	132	140	314			
836.60	88.8	83.4	34.8	32.8	5.61	2.15	10.04	19.2	17.2	38.4	19.3	21.3	100	137	136	312			
846.60	90.7	86.6	37.4	35.6	5.66	2.15	10.05	21.7	19.9	38.4	16.7	18.5	110	135	136	312			

Calculation Result = SG Reading - Tx Cable Loss + Tx Antenna Gain - Tx Antenna Attenuator Loss -2.15

Rx-ANTENNA : Biconical Antenna(30M-300MHz), Logperiodic Antenna(300M-1000MHz), Horn Antenna(1G-12.75GHz)

Tx-ANTENNA : 120MHz tuned Dipole Antenna(30M-120MHz), Dipole Antenna(120M-1000MHz), Horn Antenna(1G-12.75GHz)

Detector : S/A PK (RBW: 5MHz , VBW: 50MHz)

UL Japan, Inc.

Head Office EMC Lab.

4383-326 Asama-cho, Ise-shi, Mie-ken 516-0021 JAPAN

Telephone : +81 596 24 8116

Facsimile : +81 596 24 8124

Peak to Average power Ratio (Conducted)

Report No. 32BE0278-HO-N
Test place Head Office EMC Lab. No.7 Shielded Room
Date 10/07/2011
Temperature / Humidity 24deg.C / 56% RH
Engineer Yutaka Yoshida
Mode Tx GSM850(GSM, GMSK), 1slot, PCL=5
Tx GSM850(GPRS, GMSK), 1slot, CS-1, PCL=5
Tx GSM850(EGPRS, 8PSK), 1slot, MCS-5, PCL=5
Tx W-CDMA(RMC12.2kbps), All Up Bits

Mode	Channel	Frequency [MHz]	Peak to Average power Ratio [dB]
GSM	128	824.20	0.073
	190	836.60	0.071
	251	848.80	0.084
GPRS	128	824.20	0.027
	190	836.60	0.012
	251	848.80	0.032
EGPRS	128	824.20	5.861
	190	836.60	5.719
	251	848.80	5.952
W-CDMA	4132	826.40	3.46
	4183	836.60	3.43
	4233	846.60	3.20

Peak to Average power Ratio (Radiated)
W-CDMA Band V

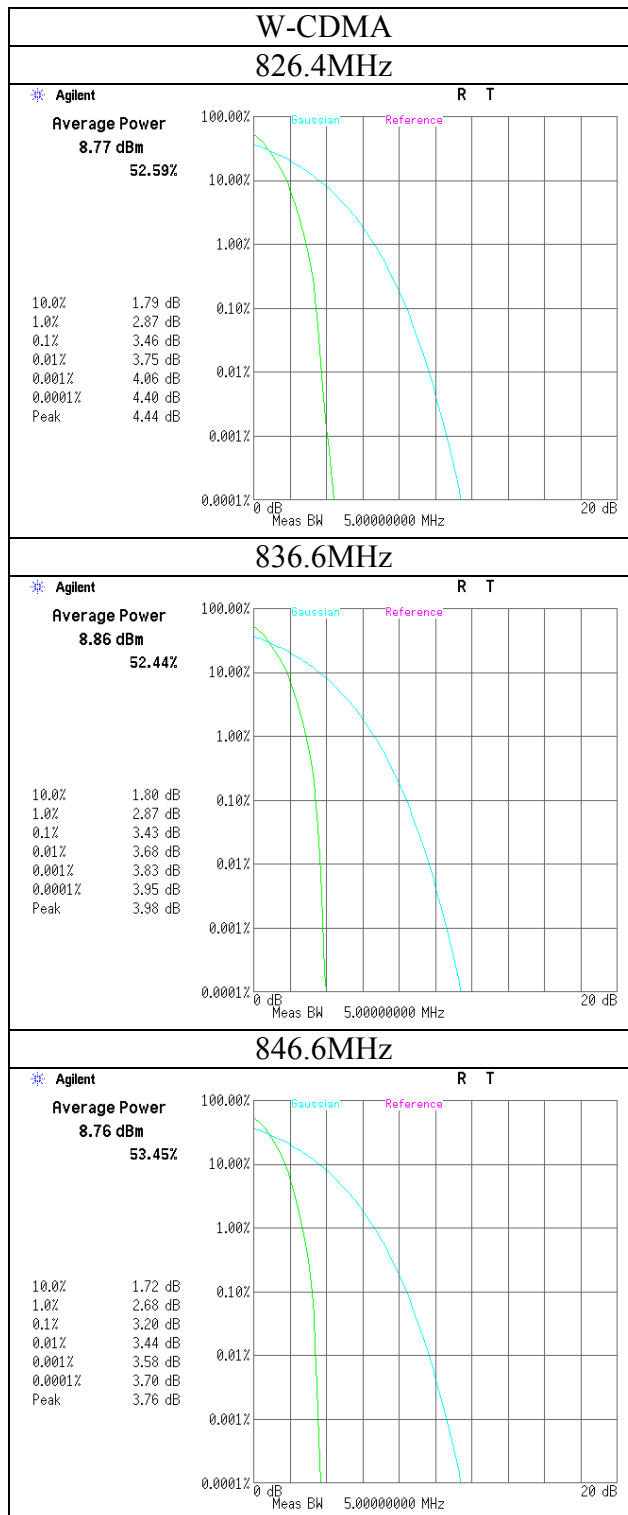

*Set the spectrum analyzer radio mode to 3GPP WCDMA (CCDF)

Bandwidth(Conducted)
GSM850

Test place : Head Office EMC Lab. No.7 Shielded Room
 Report No. : 32BE0278-HO-N
 Date : 10/07/2011
 Temperature/ Humidity : 24deg.C / 56% RH
 Engineer : Yutaka Yoshida
 Mode : Tx GSM(GMSK), 1slot, PCL=5

CH	FREQ [MHz]	26dB Bandwidth [kHz]	99% OBW [kHz]	Limit [kHz]
Mid	836.6	333.735	247.8869	-

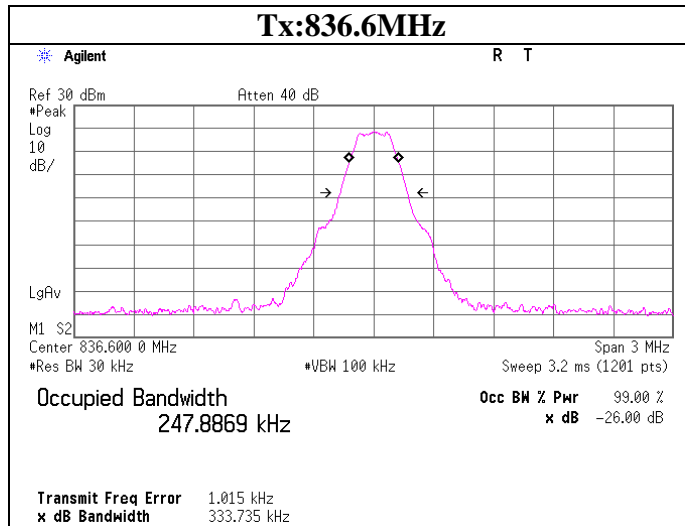

Bandwidth(Conducted)
GSM850

Test place Head Office EMC Lab. No.7 Shielded Room
 Report No. 32BE0278-HO-N
 Date 10/07/2011
 Temperature/ Humidity 24deg.C / 56% RH
 Engineer Yutaka Yoshida
 Mode Tx EGPRS(8PSK), 1slot, MCS-5, PCL=5

CH	FREQ [MHz]	26dB Bandwidth [kHz]	99% OBW [kHz]	Limit [kHz]
Mid	836.6	331.734	247.9474	-

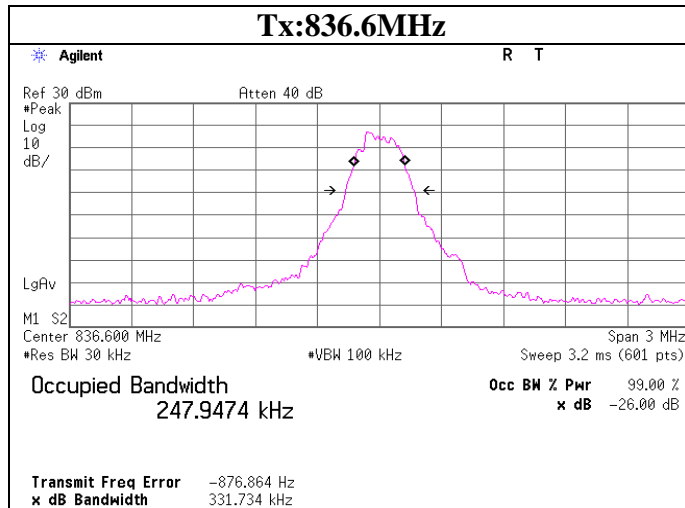

Bandwidth(Conducted)
W-CDMA Band V

Test place : Head Office EMC Lab. No.7 Shielded Room
 Report No. : 32BE0278-HO-N
 Date : 10/07/2011
 Temperature/ Humidity : 24deg.C / 56% RH
 Engineer : Yutaka Yoshida
 Mode : Tx W-CDMA(RMC12.2kbps), All Up Bits

CH	FREQ [MHz]	26dB Bandwidth [MHz]	99% OBW [MHz]	Limit [MHz]
Mid	836.6	4.582	4.0459	-

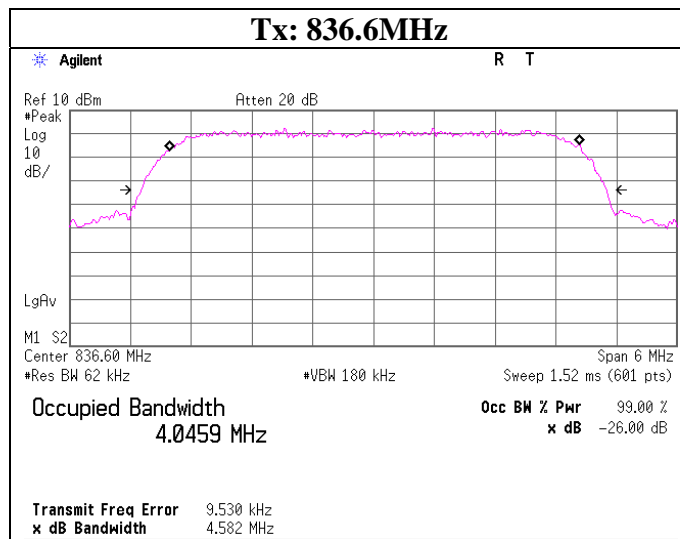

Band-Edge(Conducted)
GSM850

Test place	Head Office EMC Lab. No.7 Shielded Room
Report No.	32BE0278-HO-N
Date	10/07/2011
Temperature/ Humidity	24deg.C / 56% RH
Engineer	Yutaka Yoshida
Mode	Tx GSM(GMSK), 1slot, PCL=5

Frequency [MHz]	Reading [dBm]	Atten. [dB]	Cable Loss [dB]	Result [dBm]	Limit [dBm]	Margin [dB]
823.9807	-31.22	10.10	3.67	-17.45	-13.0	4.45
824.0000	-33.69	10.10	3.67	-19.92	-13.0	6.92
849.0000	-34.78	10.10	3.67	-21.01	-13.0	8.01
849.0185	-29.35	10.10	3.67	-15.58	-13.0	2.58

VIDEO AV 30 times
 Sample Calculation : Result = Reading + Atten. + Cable Loss

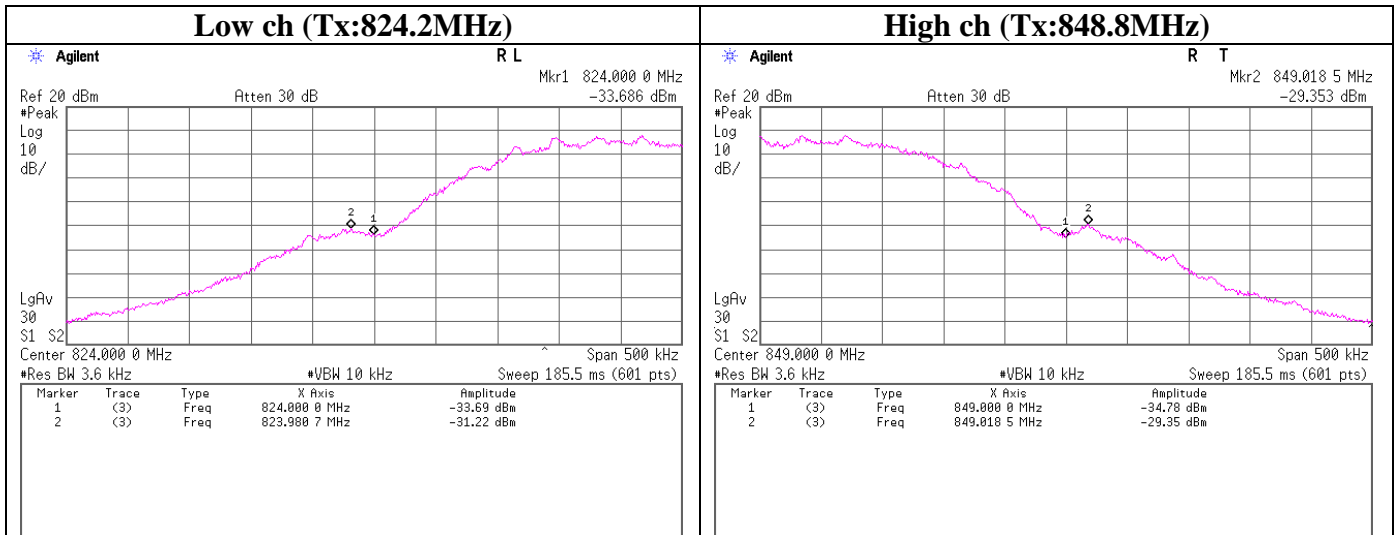

Band-Edge(Conducted)
GSM850

Test place	Head Office EMC Lab. No.7 Shielded Room
Report No.	32BE0278-HO-N
Date	10/07/2011
Temperature/ Humidity	24deg.C / 56% RH
Engineer	Yutaka Yoshida
Mode	Tx EGPRS(8PSK), 1slot, MCS-5, PCL=5

Frequency [MHz]	Reading [dBm]	Atten. [dB]	Cable Loss [dB]	Result [dBm]	Limit [dBm]	Margin [dB]
823.9866	-34.41	10.10	3.67	-20.64	-13.0	7.64
824.0000	-36.21	10.10	3.67	-22.44	-13.0	9.44
849.0000	-37.98	10.10	3.67	-24.21	-13.0	11.21
849.0034	-37.80	10.10	3.67	-24.03	-13.0	11.03

VIDEO AV 30 times
 Sample Calculation : Result = Reading + Atten. + Cable Loss

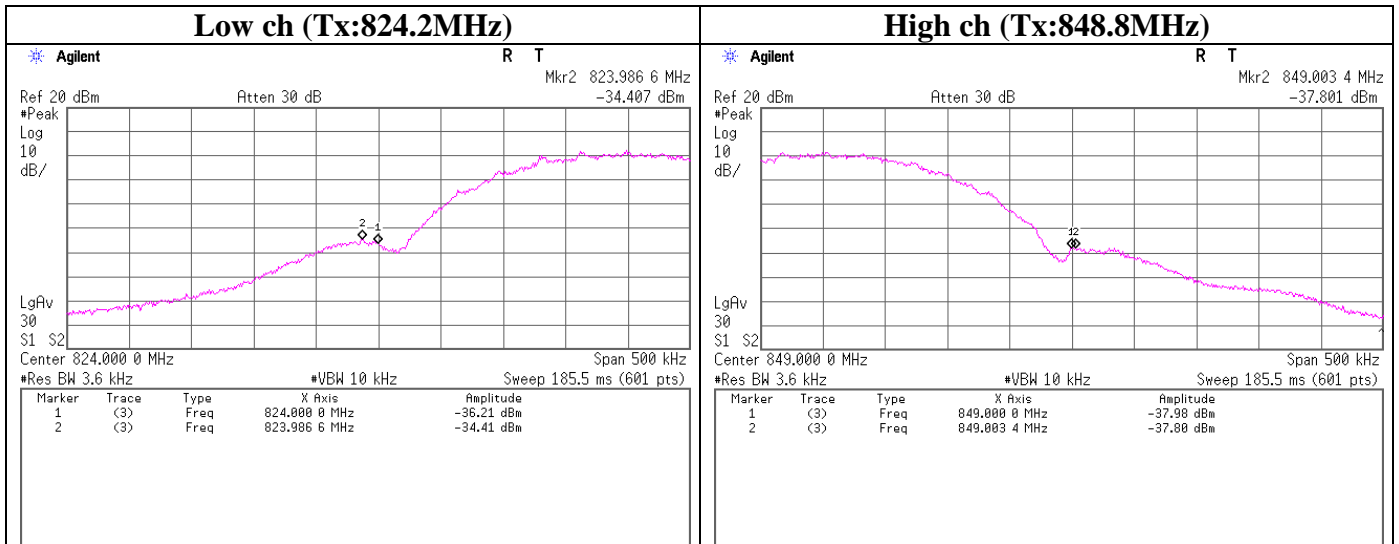

Band-Edge(Conducted)

W-CDMA Band V

Test place	Head Office EMC Lab. No.7 Shielded Room
Report No.	32BE0278-HO-N
Date	10/07/2011
Temperature/ Humidity	24deg.C / 56% RH
Engineer	Yutaka Yoshida
Mode	Tx W-CDMA(RMC12.2kbps), All Up Bits

Frequency [MHz]	Reading [dBm]	Atten. [dB]	Cable Loss [dB]	Result [dBm]	Limit [dBm]	Margin [dB]
823.9170	-33.05	10.10	3.67	-19.28	-13.0	6.28
824.0000	-35.77	10.10	3.67	-22.00	-13.0	9.00
849.0000	-37.54	10.10	3.67	-23.77	-13.0	10.77
849.1000	-36.53	10.10	3.67	-22.76	-13.0	9.76

VIDEO AV 30 times

Sample Calculation : Result = Reading + Atten. + Cable Loss

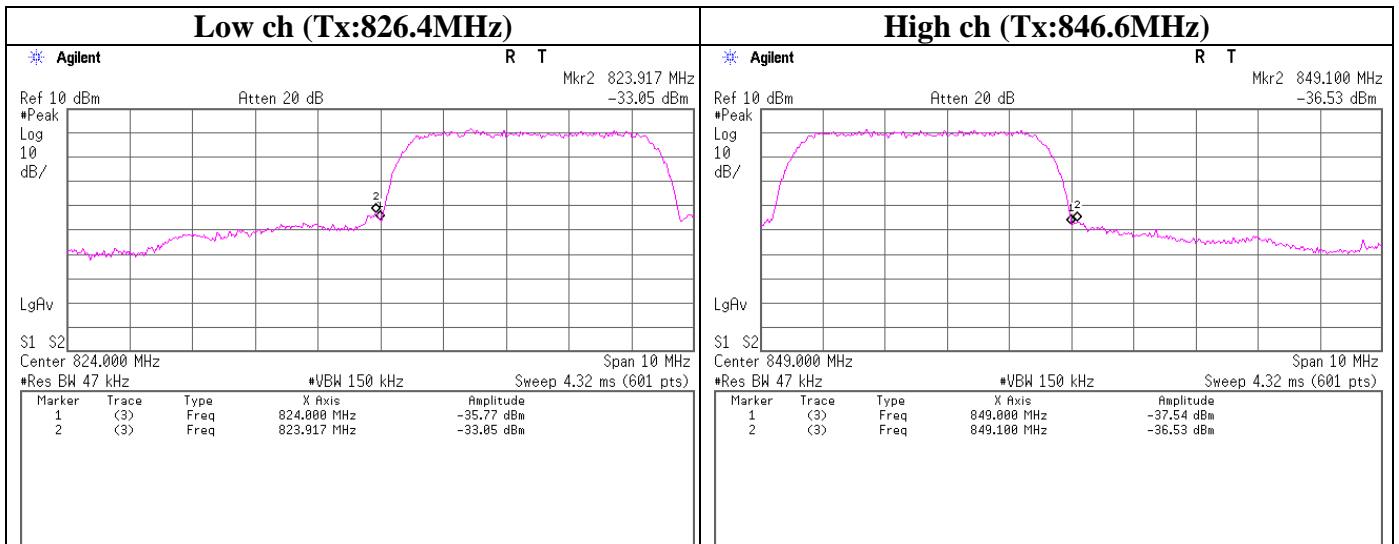

Band Edge (Radiated)
GSM850

Report No. 32BE0278-HO-N
Test place Head Office EMC Lab. No.2 Semi Anechoic Chamber
Date 09/30/2011
Temperature / Humidity 20 deg. C / 67 % RH
Engineer Keisuke Kawamura
Mode Tx GSM(GMSK), 1slot, PCL=5

Frequency [MHz]	Rx SA/TR Reading [dBuV]		Tx SG Reading [dBm]		Tx Cable Loss [dB]	Tx Ant. Gain [dBi]	Tx Ant. Atten. Loss [dB]	Result (ERP) [dBm]		Limit (ERP) [dBm]	Margin [dB]		Horizontal		Vertical		Remarks		
	HOR	VER	HOR	VER				HOR	VER		HOR	VER	HOR	VER	Rx Ant.	Turn		Rx Ant.	Turn
															Height [cm]	Table [deg.]		Height [cm]	Table [deg.]
823.98	41.9	39.5	-12.5	-10.9	5.6	2.2	10.0	-28.1	-26.5	-13.0	15.1	13.5	100	107	100	124			
824.00	37.3	34.6	-17.1	-15.8	5.6	2.2	10.0	-32.7	-31.4	-13.0	19.7	18.4	100	107	100	124			
849.00	38.1	35.4	-14.9	-14.8	5.7	2.2	10.1	-30.6	-30.6	-13.0	17.6	17.6	110	156	116	106			
849.02	47.9	42.7	-5.1	-7.5	5.7	2.2	10.1	-20.8	-23.2	-13.0	7.8	10.2	110	156	116	106			

Calculation Result = SG Reading - Tx Cable Loss + Tx Antenna Gain - Tx Antenna Attenuator Loss -2.15
Rx-ANTENNA : Biconical Antenna(30M-300MHz), Logperiodic Antenna(300M-1000MHz), Horn Antenna(1G-12.75GHz)
Tx-ANTENNA : 120MHz tuned Dipole Antenna(30M-120MHz), Dipole Antenna(120M-1000MHz), Horn Antenna(1G-12.75GHz)
Other frequency noises omitted in this report were not seen or had enough margin (more than 20dB).
NS : No signal detect.
Detector : S/A PK (RBW: 3.6kHz , VBW: 10kHz)

Band Edge (Radiated)
W-CDMA Band V

Report No. 32BE0278-HO-N
Test place Head Office EMC Lab. No.2 Semi Anechoic Chamber
Date 10/05/2011
Temperature / Humidity 23deg. C / 57% RH
Engineer Takumi Shimada
Mode Tx W-CDMA(RMC12.2kbps), All Up Bits

Frequency [MHz]	Rx SA/TR Reading [dBuV]		Tx SG Reading [dBm]		Tx Cable Loss [dB]	Tx Ant. Gain [dBi]	Tx Ant. Atten. Loss [dB]	Result (ERP) [dBm]		Limit (ERP) [dBm]	Margin [dB]		Horizontal		Vertical		Remarks		
	HOR	VER	HOR	VER				HOR	VER		HOR	VER	HOR	VER	Rx Ant.	Turn		Rx Ant.	Turn
															Height [cm]	Table [deg.]		Height [cm]	Table [deg.]
824.00	46.3	42.1	-7.5	-7.8	5.6	2.2	10.0	-23.1	-23.4	-13.0	10.1	10.4	100	132	140	314			
849.00	42.1	38.4	-11.2	-13.1	5.7	2.2	10.1	-26.9	-28.8	-13.0	13.9	15.8	110	135	136	312			

Calculation Result = SG Reading - Tx Cable Loss + Tx Antenna Gain - Tx Antenna Attenuator Loss -2.15
Rx-ANTENNA : Biconical Antenna(30M-300MHz), Logperiodic Antenna(300M-1000MHz), Horn Antenna(1G-12.75GHz)
Tx-ANTENNA : 120MHz tuned Dipole Antenna(30M-120MHz), Dipole Antenna(120M-1000MHz), Horn Antenna(1G-12.75GHz)
Detector : S/A AV (RBW: 47kHz , VBW: 150kHz)

Spurious Emission (Conducted)
GSM850

Test place Head Office EMC Lab. No.7 Shielded Room
Report No. 32BE0278-HO-N
Date 10/07/2011
Temperature/ Humidity 24deg.C / 56% RH
Engineer Yutaka Yoshida
Mode Tx GSM(GMSK), 1slot, PCL=5

Limit Line

Tx Frequency [MHz]	Limit [dBm]	Atten. [dB]	Cable Loss [dB]	Limit Line [dBm]
824.2	-13.0	10.10	3.67	-26.8
836.6	-13.0	10.10	3.67	-26.8
848.8	-13.0	10.10	3.67	-26.8

Sample Calculation : Limit Line = Limit - Atten. - Cable Loss

Spurious Emission (Conducted)
GSM
Tx:824.2MHz

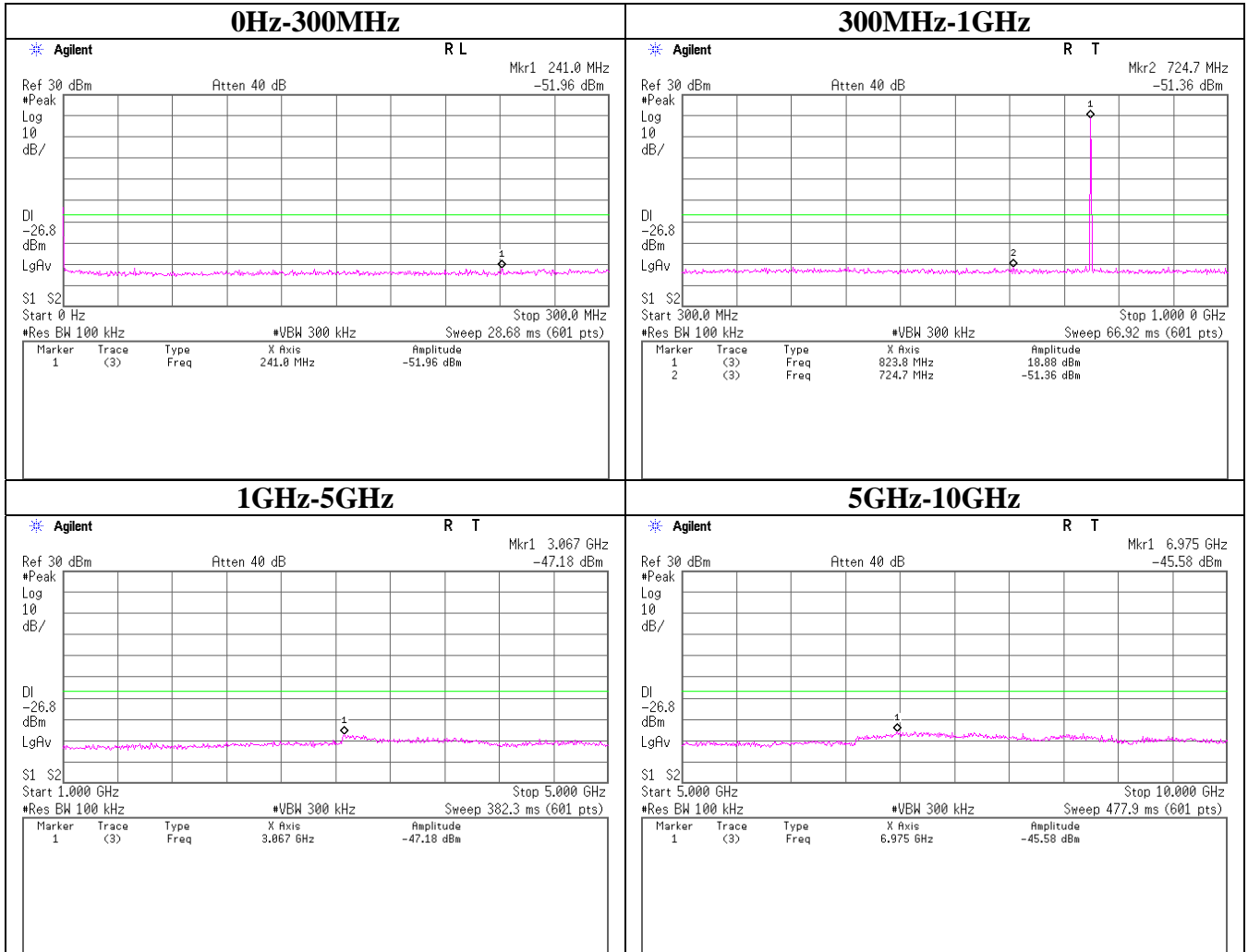

Spurious Emission (Conducted)

GSM
Tx:836.6MHz

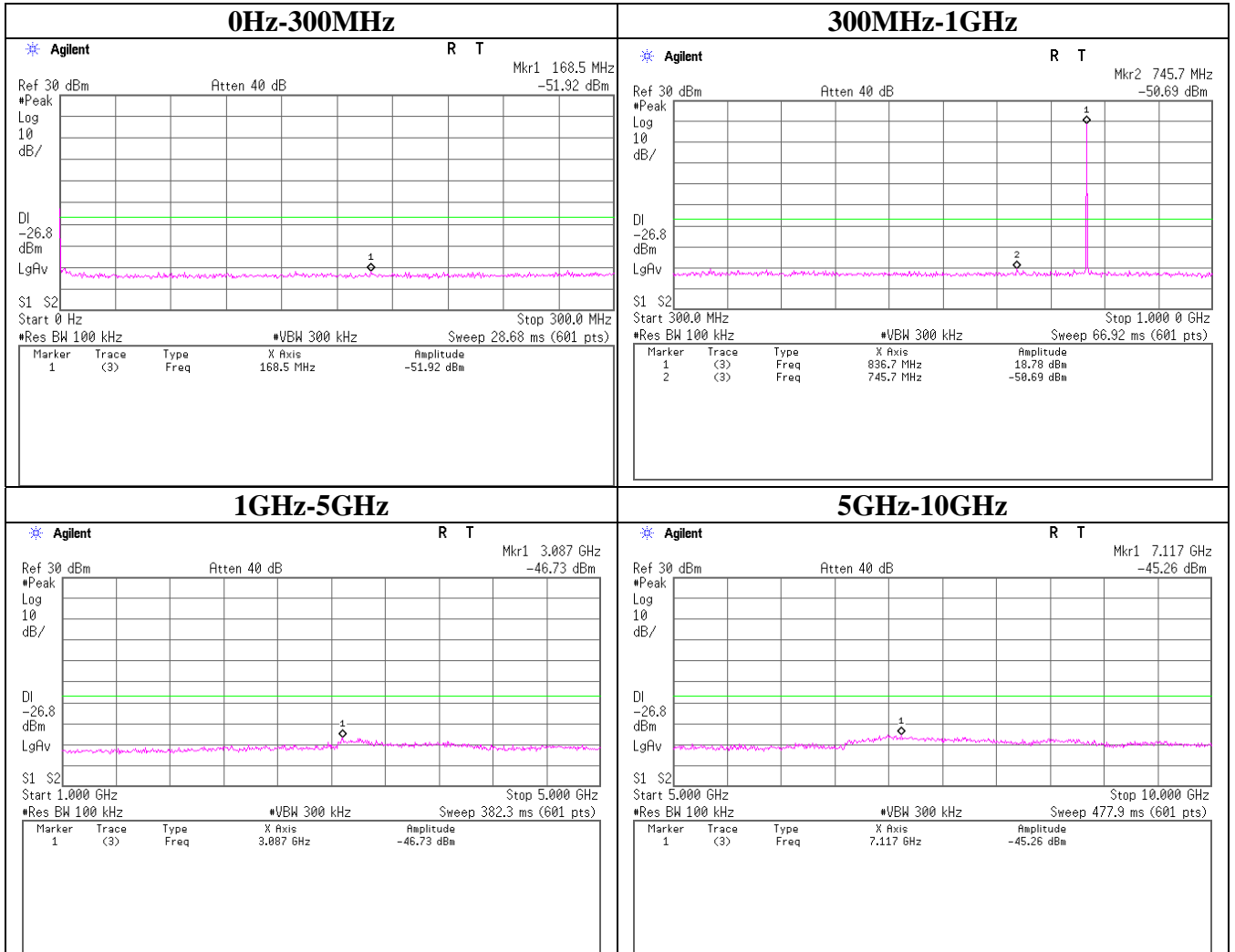

Spurious Emission (Conducted)
GSM
Tx:848.8MHz

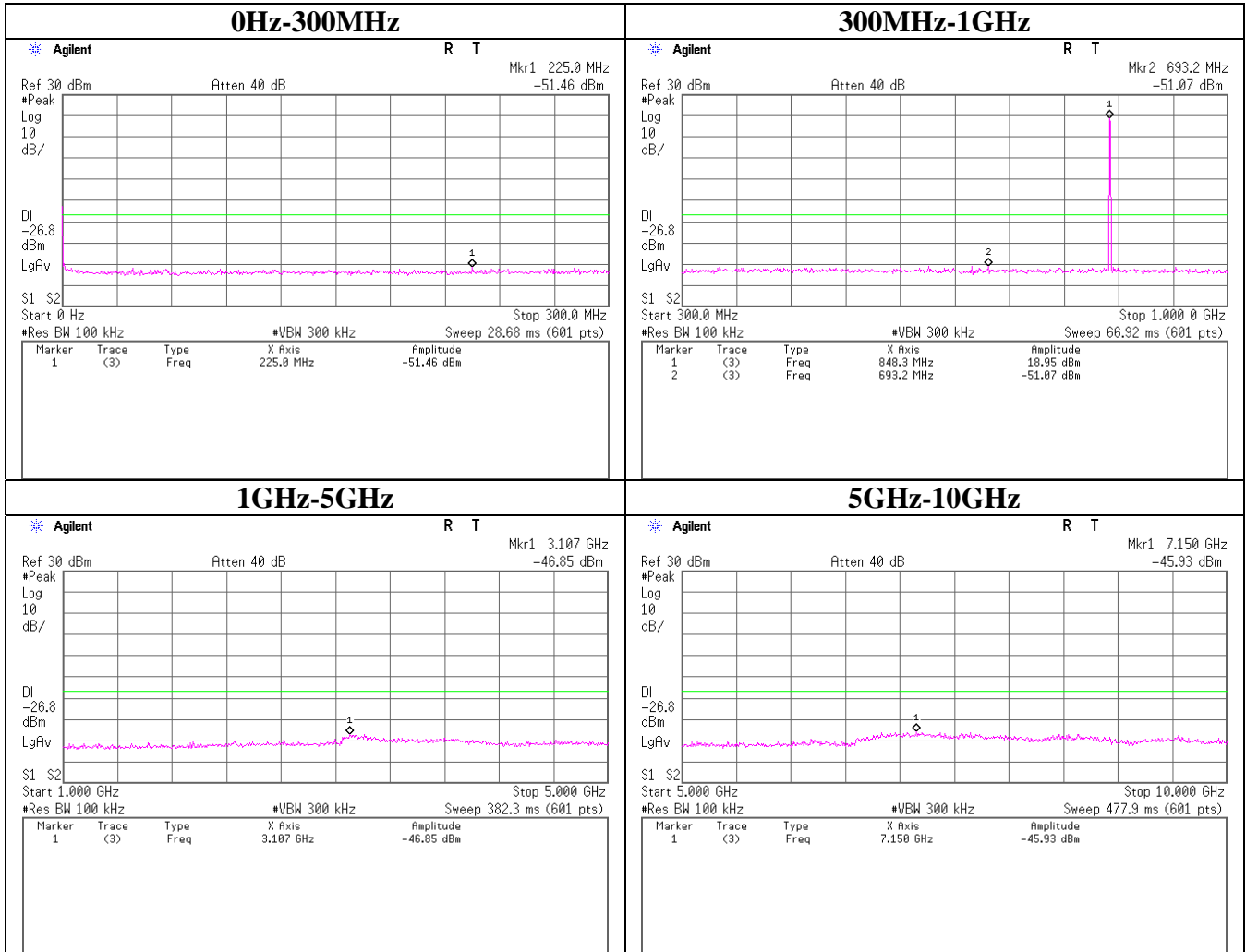

Spurious Emission (Conducted)
GSM850

Test place : Head Office EMC Lab. No.7 Shielded Room
Report No. : 32BE0278-HO-N
Date : 10/07/2011
Temperature/ Humidity : 24deg.C / 56% RH
Engineer : Yutaka Yoshida
Mode : Tx EGPRS(8PSK), 1slot, MCS-5, PCL=5

Limit Line

Tx Frequency [MHz]	Limit [dBm]	Atten. [dB]	Cable Loss [dB]	Limit Line [dBm]
824.2	-13.0	10.10	3.67	-26.8
836.6	-13.0	10.10	3.67	-26.8
848.8	-13.0	10.10	3.67	-26.8

Sample Calculation : Limit Line = Limit - Atten. - Cable Loss

*All the spurious noises were below the above limit line.

Spurious Emission (Conducted)
EGPRS
Tx:824.2MHz

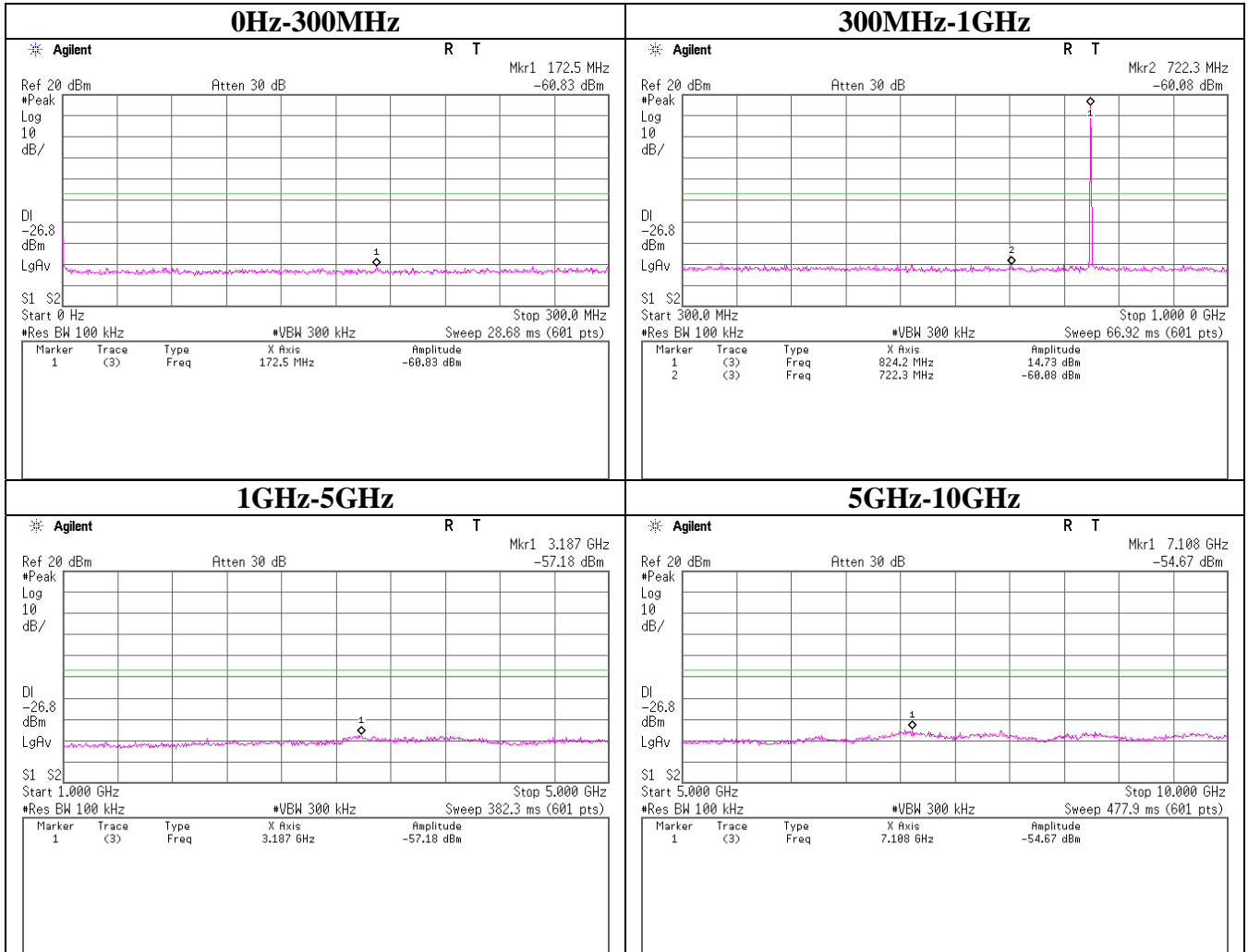

Spurious Emission (Conducted)
EGPRS
Tx:836.6MHz

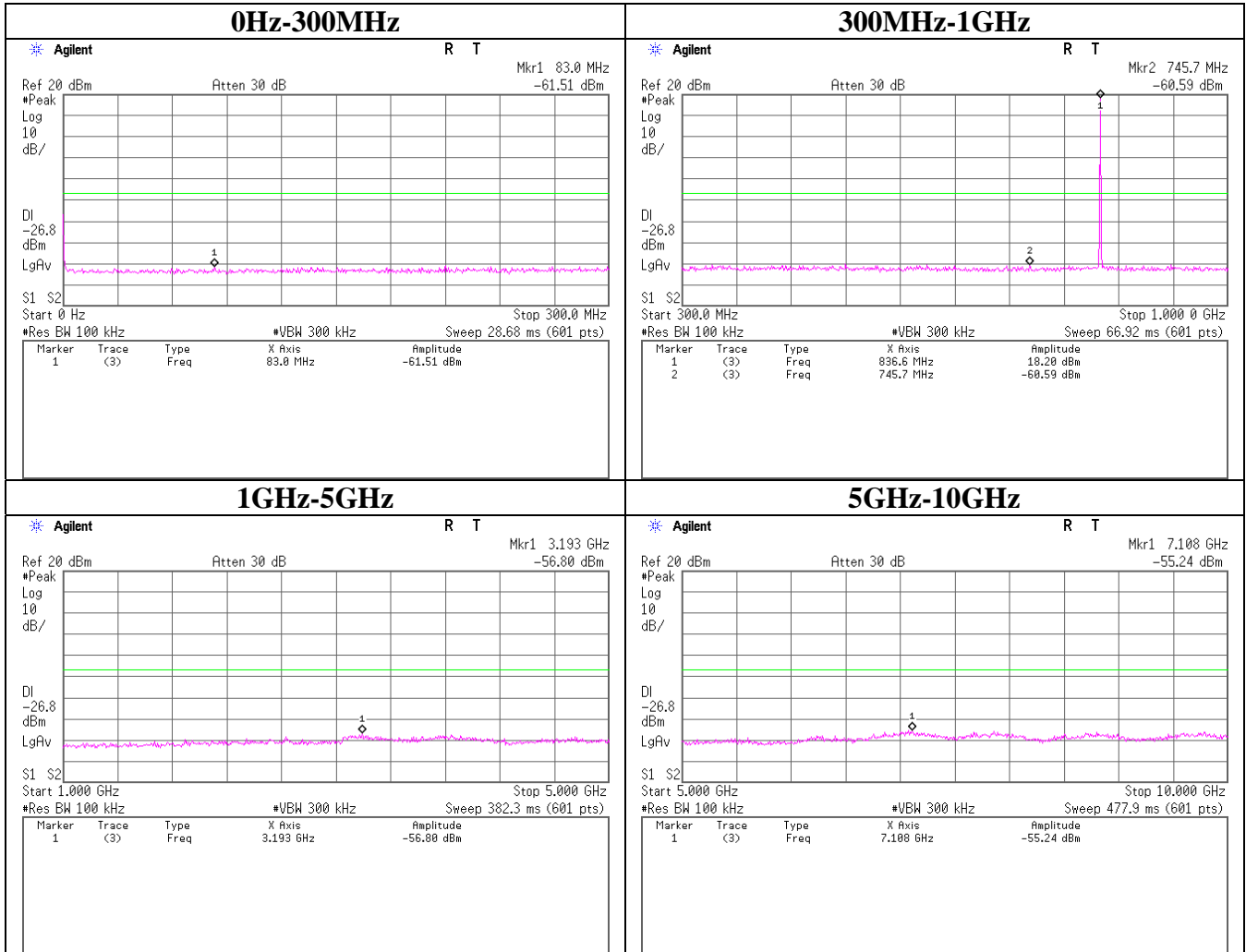

Spurious Emission (Conducted)
EGPRS
Tx:848.8MHz

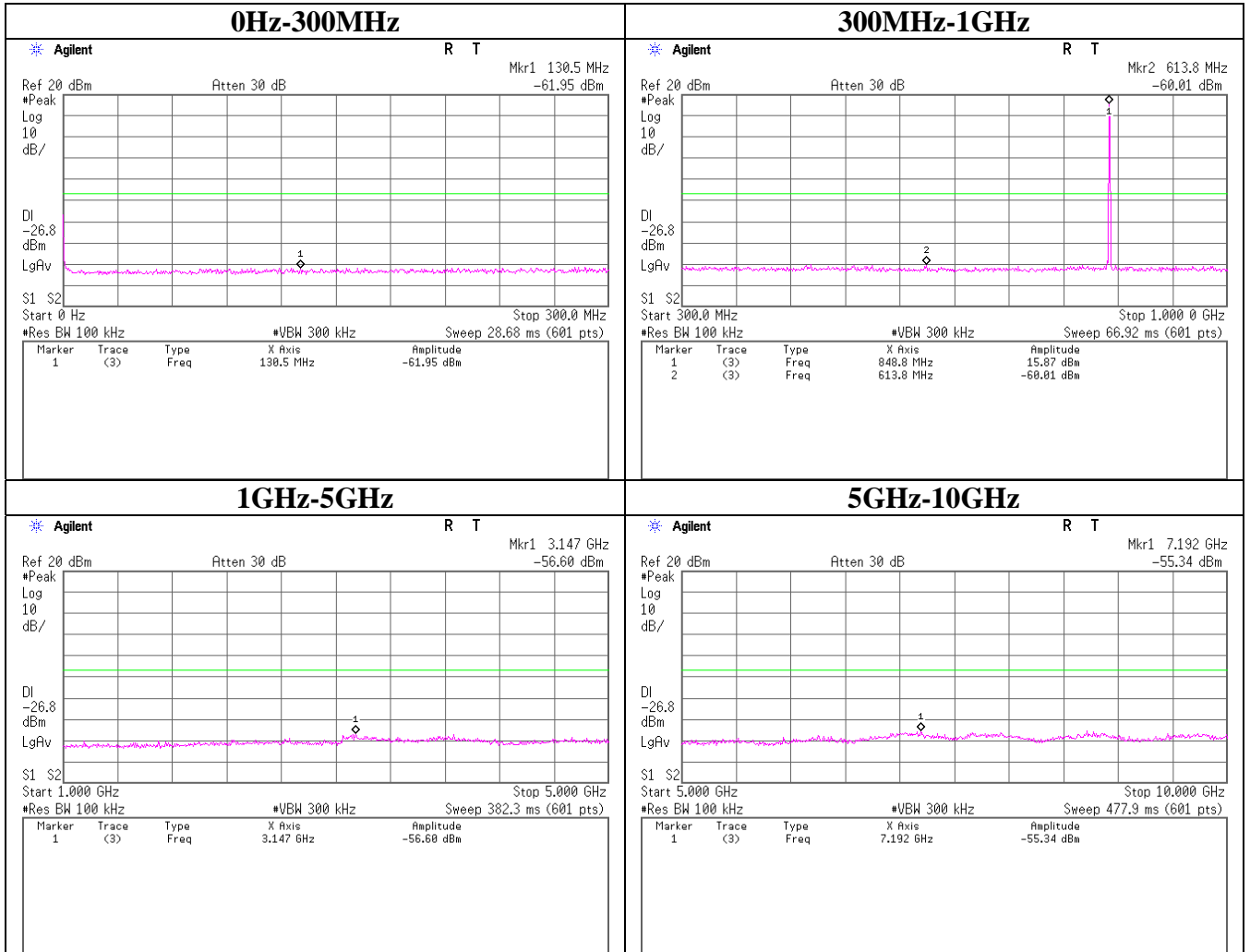

Spurious Emission (Conducted)
W-CDMA Band V

Test place Head Office EMC Lab. No.7 Shielded Room
Report No. 32BE0278-HO-N
Date 10/07/2011
Temperature/ Humidity 24deg.C / 56% RH
Engineer Yutaka Yoshida
Mode Tx W-CDMA(RMC12.2kbps), All Up Bits

Limit Line

Tx Frequency [MHz]	Limit [dBm]	Atten. [dB]	Cable Loss [dB]	Limit Line [dBm]
826.4	-13.0	10.10	3.67	-26.8
836.6	-13.0	10.10	3.67	-26.8
846.6	-13.0	10.10	3.67	-26.8

Sample Calculation : Limit Line = Limit - Atten. - Cable Loss

Spurious Emission (Conducted)
W-CDMA
Tx: 826.4MHz

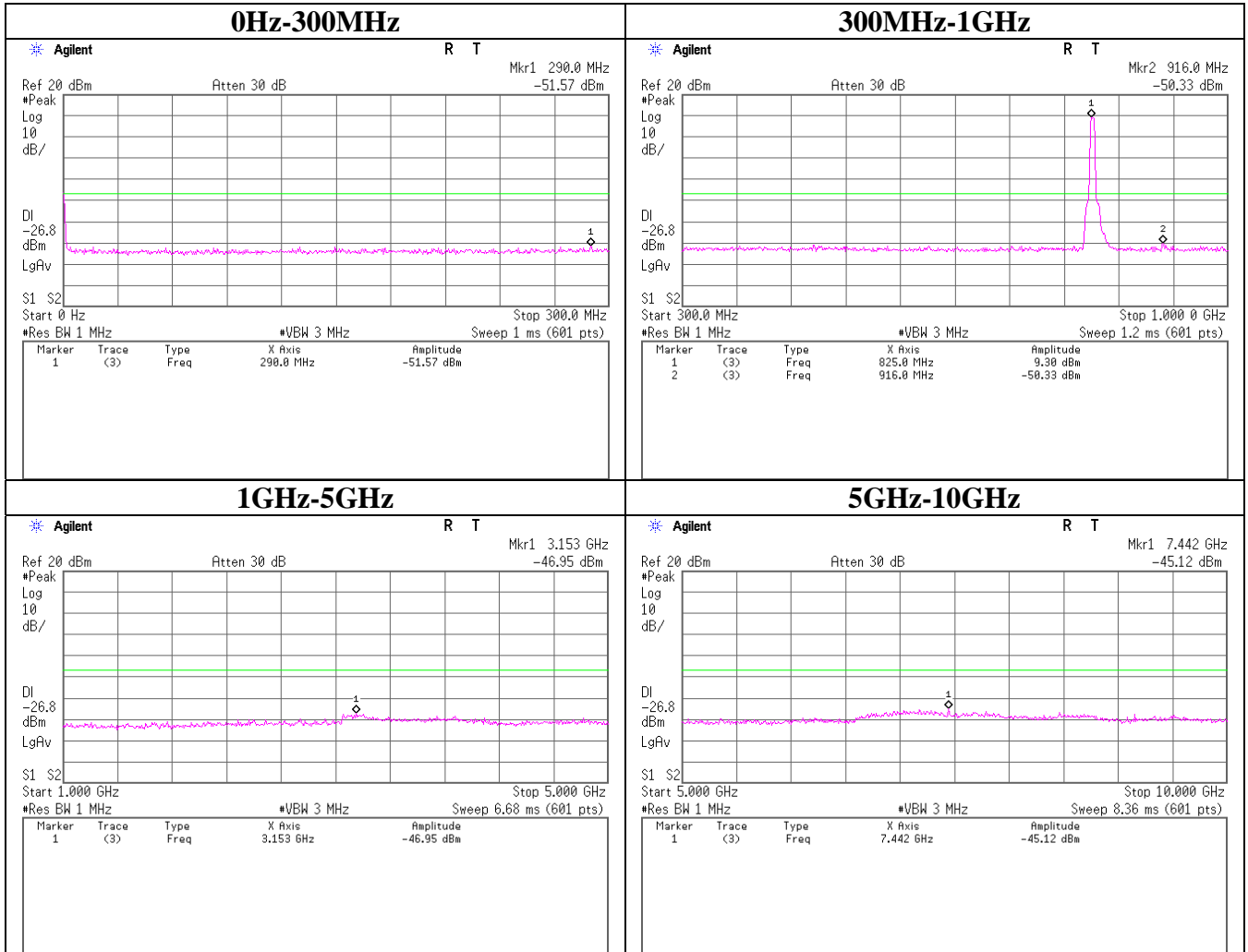

Spurious Emission (Conducted)
W-CDMA
Tx: 836.6MHz

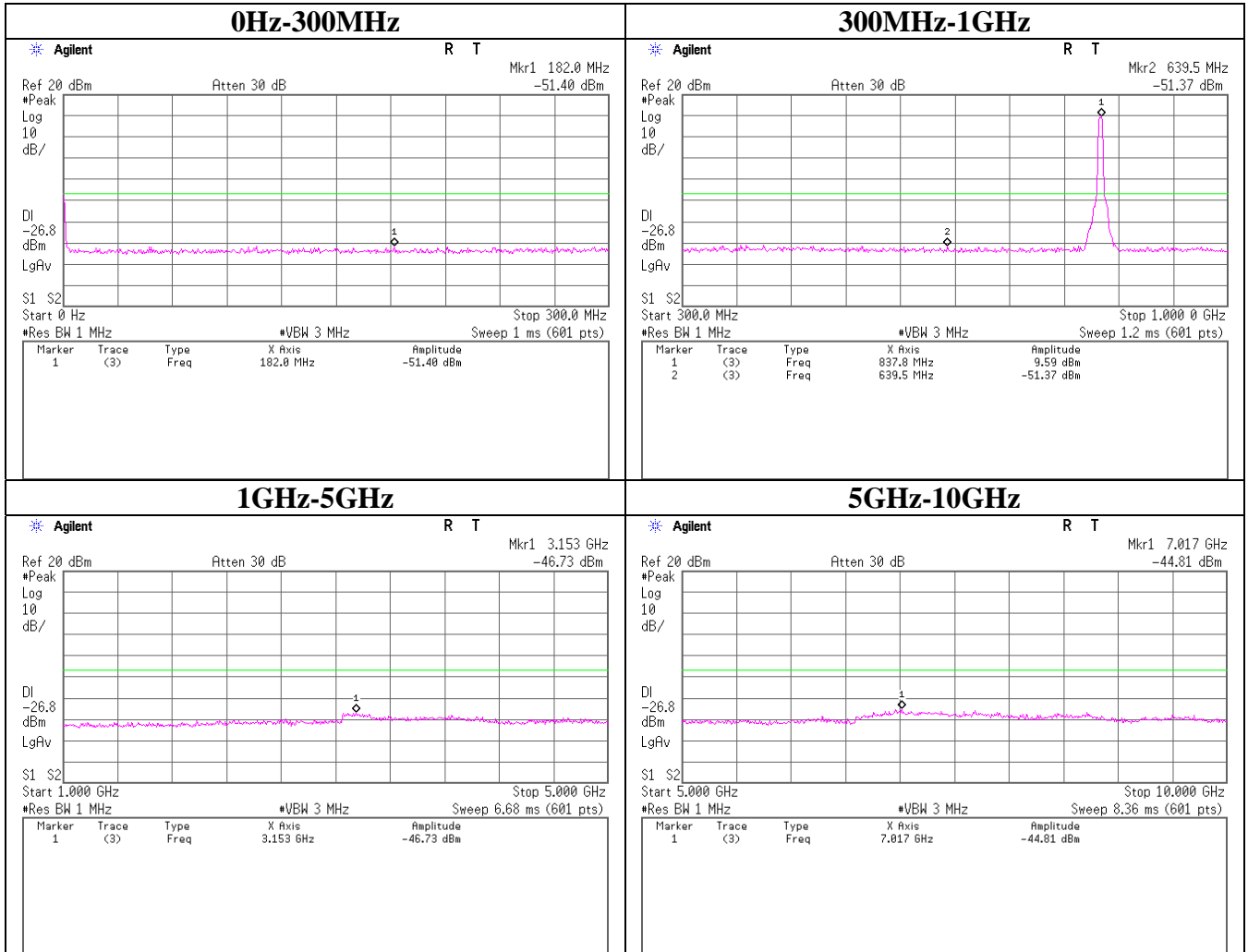

Spurious Emission (Conducted)
W-CDMA
Tx: 846.6MHz

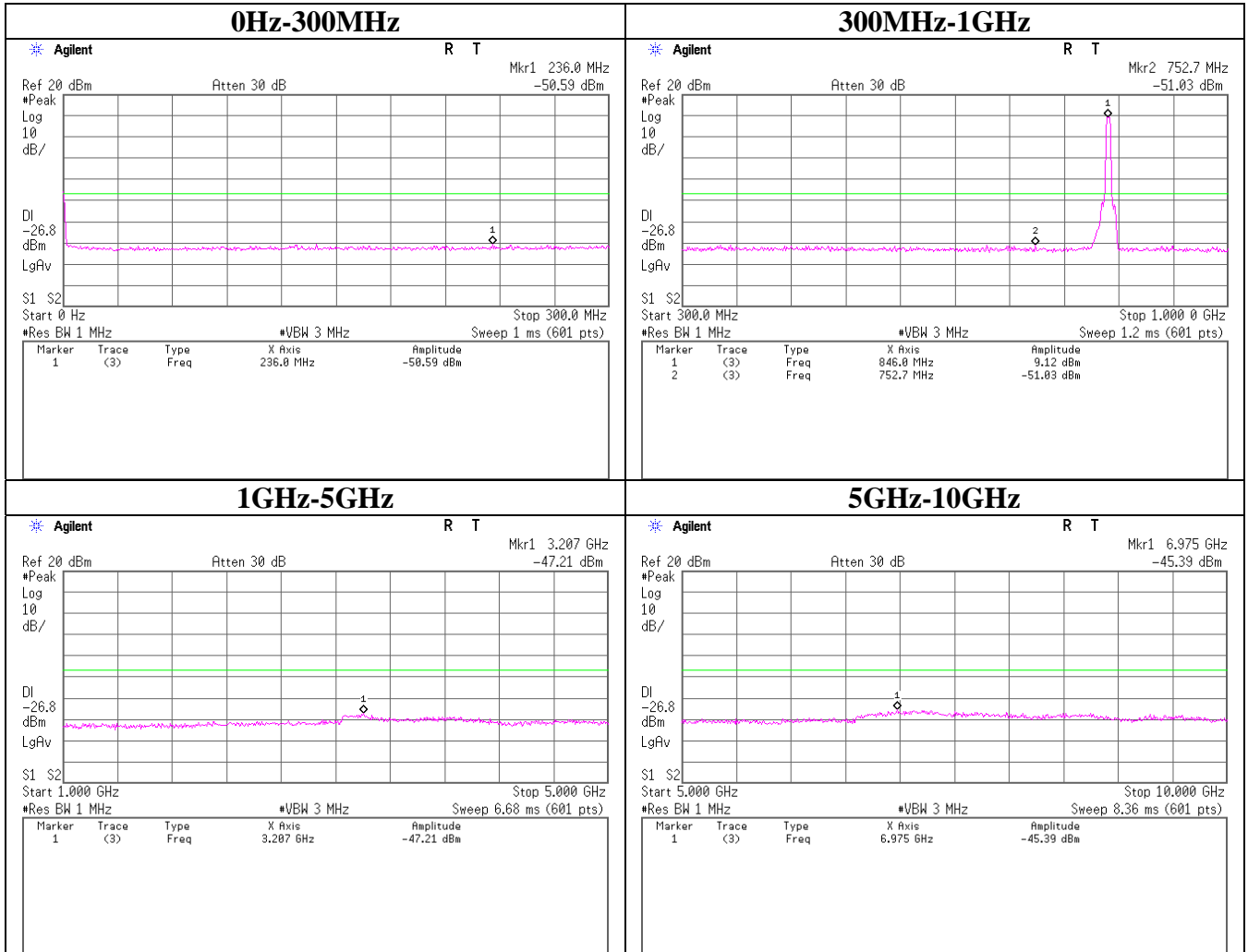

Spurious Emission (Radiated)

GSM850

Tx:824.2MHz

Report No. 32BE0278-HO-N
Test place Head Office EMC Lab. No.2 Semi Anechoic Chamber
Date 09/30/2011
Temperature / Humidity 20 deg. C. / 67 %
Engineer Keisuke Kawamura
Mode Tx GSM(GMSK), 1slot, PCL=5

Frequency [MHz]	Rx SA/TR Reading [dBuV]		Tx SG Reading [dBm]		Tx Cable Loss [dB]	Tx Ant. Gain [dBi]	Tx Ant. Atten. Loss [dB]	Result (ERP) [dBm]		Limit (ERP) [dBm]	Margin [dB]		Horizontal		Vertical		Remarks		
	HOR	VER	HOR	VER				HOR	VER		HOR	VER	HOR	VER	Rx Ant.	Turn		Rx Ant.	Turn
															Height	Table		Height	Table
1648.40	49.2	53.1	-62.1	-59.2	3.1	9.3	0.0	-58.1	-55.2	-13.0	45.1	42.2	100	172	102	222			
2472.60	64.9	61.3	-46.7	-48.4	3.8	11.0	0.0	-41.6	-43.3	-13.0	28.6	30.3	132	336	100	182			

Calculation Result = SG Reading - Tx Cable Loss + Tx Antenna Gain - Tx Antenna Attenuator Loss -2.15

Rx-ANTENNA : Biconical Antenna(30M-300MHz), Logperiodic Antenna(300M-1000MHz), Horn Antenna(1G-12.75GHz)

Tx-ANTENNA : 120MHz tuned Dipole Antenna(30M-120MHz), Dipole Antenna(120M-1000MHz), Horn Antenna(1G-12.75GHz)

Other frequency noises omitted in this report were not seen or had enough margin (more than 20dB).

Detector : S/A PK (RBW: 1MHz, VBW: 3MHz)

Spurious Emission (Radiated)

GSM850

Tx:836.6MHz

Report No. 32BE0278-HO-N
Test place Head Office EMC Lab. No.2 Semi Anechoic Chamber
Date 09/30/2011
Temperature / Humidity 20 deg. C. / 67 %
Engineer Keisuke Kawamura
Mode Tx GSM(GMSK), 1slot, PCL=5

Frequency [MHz]	Rx SA/TR Reading [dBuV]		Tx SG Reading [dBm]		Tx Cable Loss [dB]	Tx Ant. Gain [dBi]	Tx Ant. Atten. Loss [dB]	Result (ERP) [dBm]		Limit (ERP) [dBm]	Margin [dB]		Horizontal		Vertical		Remarks		
	HOR	VER	HOR	VER				HOR	VER		HOR	VER	HOR	VER	Rx Ant.	Turn		Rx Ant.	Turn
															Height	Table		Height	Table
1673.20	49.9	52.2	-61.4	-60.1	3.1	9.4	0.0	-57.3	-56.0	-13.0	44.3	43.0	176	193	143	80			
2509.80	63.9	58.7	-47.7	-51.0	3.8	11.1	0.0	-42.6	-45.9	-13.0	29.6	32.9	155	336	100	168			

Calculation Result = SG Reading - Tx Cable Loss + Tx Antenna Gain - Tx Antenna Attenuator Loss -2.15

Rx-ANTENNA : Biconical Antenna(30M-300MHz), Logperiodic Antenna(300M-1000MHz), Horn Antenna(1G-12.75GHz)

Tx-ANTENNA : 120MHz tuned Dipole Antenna(30M-120MHz), Dipole Antenna(120M-1000MHz), Horn Antenna(1G-12.75GHz)

Other frequency noises omitted in this report were not seen or had enough margin (more than 20dB).

Detector : S/A PK (RBW: 1MHz, VBW: 3MHz)

UL Japan, Inc.

Head Office EMC Lab.

4383-326 Asama-cho, Ise-shi, Mie-ken 516-0021 JAPAN

Telephone : +81 596 24 8116

Facsimile : +81 596 24 8124

Spurious Emission (Radiated)
GSM850 / Tx:848.8MHz

Report No. 32BE0278-HO-N
Test place Head Office EMC Lab. No.2 Semi Anechoic Chamber
Date 09/30/2011
Temperature / Humidity 20 deg. C. / 67 % RH
Engineer Keisuke Kawamura
Mode Tx GSM(GMSK), 1slot, PCL=5

Frequency [MHz]	Rx SA/TR Reading [dBuV]		Tx SG Reading [dBm]		Tx Cable Loss [dB]	Tx Ant. Gain [dBi]	Tx Ant. Atten. Loss [dB]	Result (ERP) [dBm]		Limit (ERP) [dBm]	Margin [dB]		Horizontal		Vertical		Remarks		
	HOR	VER	HOR	VER				HOR	VER		HOR	VER	HOR	VER	Rx Ant.	Turn		Rx Ant.	Turn
															Height	Table		Height	Table
1697.60	50.9	48.7	-60.4	-63.6	3.2	9.5	0.0	-56.2	-59.4	-13.0	43.2	46.4	100	182	180	280			
2546.40	61.4	58.8	-50.2	-50.9	3.9	11.1	0.0	-45.1	-45.8	-13.0	32.1	32.8	100	357	100	174			

Calculation Result = SG Reading - Tx Cable Loss + Tx Antenna Gain - Tx Antenna Attenuator Loss -2.15
Rx-ANTENNA : Biconical Antenna(30M-300MHz), Logperiodic Antenna(300M-1000MHz), Horn Antenna(1G-12.75GHz)
Tx-ANTENNA : 120MHz tuned Dipole Antenna(30M-120MHz), Dipole Antenna(120M-1000MHz), Horn Antenna(1G-12.75GHz)
Other frequency noises omitted in this report were not seen or had enough margin (more than 20dB).
Detector : S/A PK (RBW: 1MHz, VBW: 3MHz)

Spurious Emission (Radiated)
W-CDMA Band V / Tx: 826.4MHz

Report No. 32BE0278-HO-N
Test place Head Office EMC Lab. No.2 Semi Anechoic Chamber
Date 10/01/2011 10/05/2011
Temperature / Humidity 25deg. C / 60% RH 23deg. C / 57% RH
Engineer Satofumi Matsuyama Takumi Shimada
Mode Above 1GHz Below 1GHz
Tx W-CDMA(RMC12.2kbps), All Up Bits

Frequency [MHz]	Rx SA/TR Reading [dBuV]		Tx SG Reading [dBm]		Tx Cable Loss [dB]	Tx Ant. Gain [dBi]	Tx Ant. Atten. Loss [dB]	Result (ERP) [dBm]		Limit (ERP) [dBm]	Margin [dB]		Horizontal		Vertical		Remarks		
	HOR	VER	HOR	VER				HOR	VER		HOR	VER	HOR	VER	Rx Ant.	Turn		Rx Ant.	Turn
															Height	Table		Height	Table
1652.80	48.0	48.6	-65.2	-64.1	3.1	9.3	0.0	-61.2	-60.1	-13.0	48.2	47.1	116	21	123	97			
2479.20	50.1	46.7	-61.1	-73.0	3.8	11.0	0.0	-56.0	-67.9	-13.0	43.0	54.9	132	333	100	0			

Calculation Result = SG Reading - Tx Cable Loss + Tx Antenna Gain - Tx Antenna Attenuator Loss -2.15
Rx-ANTENNA : Biconical Antenna(30M-300MHz), Logperiodic Antenna(300M-1000MHz), Horn Antenna(1G-12.75GHz)
Tx-ANTENNA : 120MHz tuned Dipole Antenna(30M-120MHz), Dipole Antenna(120M-1000MHz), Horn Antenna(1G-12.75GHz)
Detector : S/A PK (RBW: 1MHz, VBW: 3MHz)

Spurious Emission (Radiated)
W-CDMA Band V / Tx: 836.6MHz

Report No. 32BE0278-HO-N
Test place Head Office EMC Lab. No.2 Semi Anechoic Chamber
Date 10/01/2011 10/05/2011
Temperature / Humidity 25deg. C / 60% RH 23deg. C / 57% RH
Engineer Satofumi Matsuyama Takumi Shimada
Above 1GHz Below 1GHz
Mode Tx W-CDMA(RMC12.2kbps), All Up Bits

Frequency [MHz]	Rx SA/TR Reading [dBuV]		Tx SG Reading [dBm]		Tx Cable Loss [dB]	Tx Ant. Gain [dBi]	Tx Ant. Atten. Loss [dB]	Result (ERP) [dBm]		Limit (ERP) [dBm]	Margin [dB]		Horizontal		Vertical		Remarks		
	HOR	VER	HOR	VER				HOR	VER		HOR	VER	HOR	VER	Rx Ant.	Turn		Rx Ant.	Turn
															Height [cm]	Table [deg.]		Height [cm]	Table [deg.]
1673.20	50.7	48.5	-62.5	-64.2	3.1	9.4	0.0	-58.4	-60.1	-13.0	45.4	47.1	110	19	124	117			
2509.80	46.5	45.1	-64.7	-74.7	3.8	11.1	0.0	-59.6	-69.6	-13.0	46.6	56.6	121	331	100	0			

Calculation Result = SG Reading - Tx Cable Loss + Tx Antenna Gain - Tx Antenna Attenuator Loss -2.15
Rx-ANTENNA : Biconical Antenna(30M-300MHz), Logperiodic Antenna(300M-1000MHz), Horn Antenna(1G-12.75GHz)
Tx-ANTENNA : 120MHz tuned Dipole Antenna(30M-120MHz), Dipole Antenna(120M-1000MHz), Horn Antenna(1G-12.75GHz)
Detector : S/A PK (RBW: 1MHz , VBW: 3MHz)

Spurious Emission (Radiated)
W-CDMA Band V / Tx: 846.6MHz

Report No. 32BE0278-HO-N
Test place Head Office EMC Lab. No.2 Semi Anechoic Chamber
Date 10/01/2011 10/05/2011
Temperature / Humidity 25deg. C / 60% RH 23deg. C / 57% RH
Engineer Satofumi Matsuyama Takumi Shimada
Above 1GHz Below 1GHz
Mode Tx W-CDMA(RMC12.2kbps), All Up Bits

Frequency [MHz]	Rx SA/TR Reading [dBuV]		Tx SG Reading [dBm]		Tx Cable Loss [dB]	Tx Ant. Gain [dBi]	Tx Ant. Atten. Loss [dB]	Result (ERP) [dBm]		Limit (ERP) [dBm]	Margin [dB]		Horizontal		Vertical		Remarks		
	HOR	VER	HOR	VER				HOR	VER		HOR	VER	HOR	VER	Rx Ant.	Turn		Rx Ant.	Turn
															Height [cm]	Table [deg.]		Height [cm]	Table [deg.]
1693.20	50.5	53.5	-62.7	-59.2	3.2	9.5	0.0	-58.6	-55.1	-13.0	45.6	42.1	121	18	112	342			
2539.80	47.0	44.8	-64.2	-75.0	3.8	11.1	0.0	-59.1	-69.9	-13.0	46.1	56.9	152	316	118	5			
3386.40	45.3	43.9	-71.8	-75.4	4.5	12.5	0.0	-65.9	-69.5	-13.0	52.9	56.5	100	145	100	340			

Calculation Result = SG Reading - Tx Cable Loss + Tx Antenna Gain - Tx Antenna Attenuator Loss -2.15
Rx-ANTENNA : Biconical Antenna(30M-300MHz), Logperiodic Antenna(300M-1000MHz), Horn Antenna(1G-12.75GHz)
Tx-ANTENNA : 120MHz tuned Dipole Antenna(30M-120MHz), Dipole Antenna(120M-1000MHz), Horn Antenna(1G-12.75GHz)
Detector : S/A PK (RBW: 1MHz , VBW: 3MHz)

Frequency Stability(Temperature/Voltage Variation)
GSM850
Tx:836.6MHz

Test place : Head Office EMC Lab. No.7 Measurement Room
 Report No. : 32BE0278-HO-N
 Date : 10/08/2011
 Temperature/ Humidity : 24 deg.C./ 41% RH
 Engineer : Keisuke Kawamura
 Mode : Tx GSM(GMSK), 1slot, PCL=5

Temp. [deg.C]	Volt. [V]	Frequency Reading [MHz]	Frequency Error [Hz]	Frequency Error [ppm]	Limit [ppm]
-30	4.00	836.60001241	2.15	0.003	2.5
-20	4.00	836.60001586	1.30	0.002	2.5
-10	4.00	836.60001588	1.32	0.002	2.5
0	4.00	836.60002027	5.71	0.007	2.5
10	4.00	836.60001559	1.03	0.001	2.5
20	4.00	836.60001456	0.00	0.000	Reference
30	4.00	836.60001348	1.08	0.001	2.5
40	4.00	836.60001127	3.29	0.004	2.5
50	4.00	836.60001196	2.60	0.003	2.5

Temp. [deg.C]	Volt. [V]	Frequency Reading [MHz]	Frequency Error [Hz]	Frequency Error [ppm]	Limit [ppm]
20	4.20	836.60001343	1.13	0.001	2.5
20	4.00	836.60001456	0.00	0.000	Reference
20	3.70	836.60001634	1.78	0.002	2.5

Frequency Stability(Temperature/Voltage Variation)
W-CDMA Band V
Tx: 836.6MHz

Test place Head Office EMC Lab. No.7 Measurement Room
Report No. 32BE0278-HO-N
Date 10/08/2011
Temperature/ Humidity 24 deg.C / 41% RH
Engineer Keisuke Kawamura
Mode Tx W-CDMA(RMC12.2kbps), All Up Bits

Temp. [deg.C]	Volt. [V]	Frequency Reading [MHz]	Frequency Error [Hz]	Frequency Error [ppm]	Limit [ppm]
-30.0	4.00	836.59999382	0.51	0.001	2.5
-20.0	4.00	836.59999513	0.80	0.001	2.5
-10.0	4.00	836.60000531	10.98	0.013	2.5
0.0	4.00	836.60000529	10.96	0.013	2.5
10.0	4.00	836.60000433	10.00	0.012	2.5
20.0	4.00	836.59999433	0.00	0.000	Reference
30.0	4.00	836.59999501	0.68	0.001	2.5
40.0	4.00	836.59999387	0.46	0.001	2.5
50.0	4.00	836.60000450	10.17	0.012	2.5

Temp. [deg.C]	Volt. [V]	Frequency Reading [MHz]	Frequency Error [Hz]	Frequency Error [ppm]	Limit [ppm]
20.0	4.20	836.59999657	2.24	0.003	2.5
20.0	4.00	836.59999433	0.00	0.000	Reference
20.0	3.70	836.60000680	12.47	0.015	2.5

APPENDIX 3: Test instruments

EMI test equipment (1/2)

Control No.	Instrument	Manufacturer	Model No	Serial No	Test Item	Calibration Date * Interval(month)
MAEC-02	Semi Anechoic Chamber(NSA)	TDK	Semi Anechoic Chamber 3m	DA-06902	RE	2011/06/21 * 12
MOS-22	Thermo-Hygrometer	Custom	CTH-201	0003	RE	2011/02/23 * 12
MJM-14	Measure	KOMELON	KMC-36	-	RE	-
COTS-MEMI	EMI measurement program	TSJ	TEPTO-DV	-	RE	-
MSA-03	Spectrum Analyzer	Agilent	E4448A	MY44020357	RE/AT	2010/11/30 * 12
MBA-02	Biconical Antenna	Schwarzbeck	BBA9106	VHA91032008	RE	2011/09/10 * 12
MLA-02	Logperiodic Antenna	Schwarzbeck	USLP9143	201	RE	2011/09/10 * 12
MCC-12	Coaxial Cable	Fujikura/Agilent	-	-	RE	2011/02/18 * 12
MAT-07	Attenuator(6dB)	Weinschel Corp	2	BK7970	RE	2010/11/05 * 12
MPA-09	Pre Amplifier	Agilent	8447D	2944A10845	RE	2011/09/26 * 12
MHA-06	Horn Antenna 1-18GHz	Schwarzbeck	BBHA9120D	254	RE	2011/01/16 * 12
MPA-10	Pre Amplifier	Agilent	8449B	3008A02142	RE	2011/09/21 * 12
MCC-132	Microwave Cable	HUBER+SUHNER	SUCOFLEX104	336161/4(1m) / 340639(5m)	RE	2011/09/06 * 12
MHF-03	High pass Filter 1.4-5.0GHz	Mini-Circuit	VHF-1320	10411	RE	2011/08/25 * 12
MSG-09	Signal Generator	Wiltron	68247B	674005	RE	2011/02/05 * 12
MDA-04	Dipole Antenna	Schwarzbeck	UHAP	992	RE	2010/10/16 * 12
MCC-125	Corexial Cable	UL Japan	-	-	RE	2011/07/04 * 12
MHA-20	Horn Antenna 1-18GHz	Schwarzbeck	BBHA9120D	258	RE	2011/05/23 * 12
MCC-129	Microwave Cable(1-33GHz)	HUBER+SUHNER	SF103/11PC3.5-31	54307/3	RE	2011/01/06 * 12
KSG-05	Signal Generator	Rohde & Schwarz	SMR40	100137	RE	2011/08/30 * 12
MHF-04	High Pass Filter 1.22-4.60GHz	Mini-Circuit	VHF-1200	10435	RE	2011/08/25 * 12
MHA-02	Horn Antenna 18-26.5GHz	EMCO	3160-09	1265	RE	2011/01/16 * 12
MURC-02	Wireless Communication Test Set	Agilent	E5515C	GB47050683	AT	2009/10/20 * 36
MCC-97	Microwave Cable 1G-40GHz	Schner	SUCOFLEX102	30818/2	AT	2011/05/27 * 12
MCC-98	Microwave Cable 1G-40GHz	Schner	SUCOFLEX102	30819/2	AT	2011/05/27 * 12
MAT-22	Attenuator(10dB) 1-18GHz	Orient Microwave	BX10-0476-00	-	AT	2011/03/14 * 12
MAT-23	Attenuator(10dB) 1-18GHz	Orient Microwave	BX10-0476-00	-	AT	2011/03/14 * 12
MPSC-01	Power splitters/Combiners	Mini-Circuit	ZFSC-2-2500	0124	AT	2011/09/27 * 12
MOS-04	Digital Humidity Indicator	N.T	NT-1800	MOS04	AT	2011/02/23 * 12
KCH-01	Temperature and Humidity Chamber	Tabai Espec	PL-1KT	14007630	AT	2011/04/27 * 12

UL Japan, Inc.

Head Office EMC Lab.

4383-326 Asama-cho, Ise-shi, Mie-ken 516-0021 JAPAN

Telephone : +81 596 24 8116

Facsimile : +81 596 24 8124

EMI test equipment (2/2)

Control No.	Instrument	Manufacturer	Model No	Serial No	Test Item	Calibration Date * Interval(month)
MOS-19	Thermo-Hygrometer	Custom	CTH-201	0001	AT	2010/12/13 * 12
MURC-02	Wireless Communication Test Set	Agilent	E5515C	GB47050683	AT	2009/10/20 * 36
MPSE-11	Power sensor	Anritsu	MA2411B	011737	AT	2011/09/13 * 12
MPM-08	Power Meter	Anritsu	ML2495A	6K00003338	AT	2011/09/13 * 12
MAT-22	Attenuator(10dB) 1- 18GHz	Orient Microwave	BX10-0476-00	-	AT	2011/03/14 * 12
MAT-23	Attenuator(10dB) 1- 18GHz	Orient Microwave	BX10-0476-00	-	AT	2011/03/14 * 12
MPSC-01	Power splitters/Combiners	Mini-Circuit	ZFSC-2-2500	0124	AT	2011/09/27 * 12
MAT-24	Attenuator(10dB)(above 1GHz)	Agilent	8493C	71389	AT	2011/06/23 * 12
MCC-91	Microwave Cable 1G- 40GHz	Schner	SUCOFLEX102	30812/2	AT	2011/05/27 * 12
MCC-96	Microwave Cable 1G- 40GHz	Schner	SUCOFLEX102	30817/2	AT	2011/05/27 * 12
MAT-25	Attenuator(10dB)(above 1GHz)	Agilent	8493C	71642	AT	2011/06/23 * 12

The expiration date of the calibration is the end of the expired month.

All equipment is calibrated with valid calibrations. Each measurement data is traceable to the national or international standards.

As for some calibrations performed after the tested dates, those test equipment have been controlled by means of an unbroken chains of calibrations.

Test Item:

RE: Radiated Emission

AT: Antenna terminal conducted test

UL Japan, Inc.

Head Office EMC Lab.

4383-326 Asama-cho, Ise-shi, Mie-ken 516-0021 JAPAN

Telephone : +81 596 24 8116

Facsimile : +81 596 24 8124