



# RADIO TEST REPORT

**Test Report No. : 32BE0278-HO-K**

**Applicant** : SAMSUNG ELECTRONICS CO., LTD.  
**Type of Equipment** : Cellular/PCS GSM/GPRS/EDGE, Cellular/PCS WCDMA Tablet with 802.11abgn, BT3.0  
**Model No.** : GT-P6200L  
**FCC ID** : A3LGTP6200L  
**Test regulation** : FCC Part 15 Subpart C: 2011  
**Test Result** : Complied

1. This test report shall not be reproduced in full or partial, without the written approval of UL Japan, Inc.
2. The results in this report apply only to the sample tested.
3. This sample tested is in compliance with the above regulation.
4. The test results in this report are traceable to the national or international standards.
5. This test report must not be used by the customer to claim product certification, approval, or endorsement by NVLAP, NIST, or any agency of the Federal Government.

**Date of test:** October 4 to 7, 2011

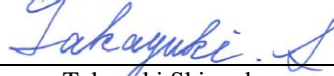
**Representative test engineer:**   
Takayuki Shimada  
Engineer of WiSE Japan,  
UL Verification Service

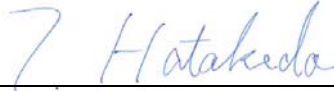
**Approved by:**   
Takahiro Hatakeda  
Leader of WiSE Japan,  
UL Verification Service

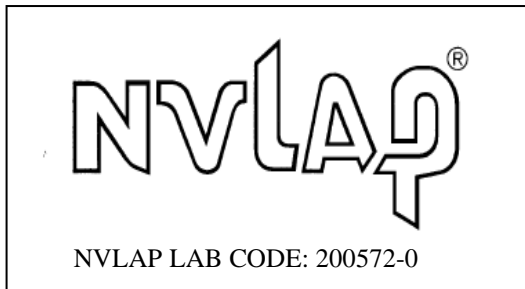

This laboratory is accredited by the NVLAP LAB CODE 200572-0, U.S.A. The tests reported herein have been performed in accordance with its terms of accreditation. \*As for the range of Accreditation in NVLAP, you may refer to the WEB address, <http://www.ul.com/japan/jpn/pages/services/emc/about/mark1/index.jsp#nvlap>

<b>CONTENTS</b>	<b>PAGE</b>
<b>SECTION 1: Customer information</b> .....	<b>3</b>
<b>SECTION 2: Equipment under test (E.U.T.)</b> .....	<b>3</b>
<b>SECTION 3: Test specification, procedures &amp; results</b> .....	<b>5</b>
<b>SECTION 4: Operation of E.U.T. during testing</b> .....	<b>8</b>
<b>SECTION 5: Conducted Emission</b> .....	<b>10</b>
<b>SECTION 6: Radiated Spurious Emission</b> .....	<b>11</b>
<b>SECTION 7: Antenna Terminal Conducted Tests</b> .....	<b>12</b>
<b>APPENDIX 1: Data of EMI test</b> .....	<b>13</b>
Conducted Emission .....	13
20dB Bandwidth and Carrier Frequency Separation .....	17
Number of Hopping Frequency .....	20
Dwell time .....	22
Maximum Peak Output Power.....	25
Radiated Spurious Emission .....	26
Conducted Spurious Emission.....	33
Conducted Emission Band Edge compliance .....	45
99% Occupied Bandwidth .....	47
<b>APPENDIX 2: Test instruments</b> .....	<b>49</b>
<b>APPENDIX 3: Photographs of test setup</b> .....	<b>50</b>
Conducted Emission .....	50
Radiated Spurious Emission .....	51
Worst Case Position (Horizontal: Z-axis/ Vertical:Z-axis) .....	52

**SECTION 1: Customer information**

Company Name : SAMSUNG ELECTRONICS CO., LTD.  
Address : 416, MAETAN 3-DONG, YEONGTONG-GU SUWON-CITY,  
GYEONGGI-DO 443-742, SOUTH KOREA

**SECTION 2: Equipment under test (E.U.T.)**

**2.1 Identification of E.U.T.**

Type of Equipment : Cellular/PCS GSM/GPRS/EDGE, Cellular/PCS WCDMA Tablet with  
802.11abgn, BT3.0  
Model No. : GT-P6200L  
Serial No. : Refer to Section 4, Clause 4.2  
Rating : DC4.0V  
Receipt Date of Sample : September 27, 2011  
Modification of EUT : No Modification by the test lab

**2.2 Product Description**

**Radio Specification**

**Bluetooth**

Equipment Type	Transceiver
Frequency of Operation	2402-2480MHz
Type of Modulation	FHSS
Bandwidth & Channel spacing	1MHz & 1MHz
Antenna Type	PIFA
Antenna Gain	-0.63 dBi

**WLAN (IEEE802.11a/b/g/n-20)**

Equipment Type	Transceiver	
Frequency of Operation	2412-2462MHz	5180-5240MHz 5260-5320MHz 5500-5700MHz 5745-5825MHz
Type of Modulation	DSSS, OFDM	OFDM
Bandwidth & Channel spacing	20MHz & 5MHz	20MHz & 20MHz
Antenna Type	SEMI-PIFA	
Antenna Gain	2.4G: -2.85dBi	5G: -4.15dBi

**WLAN (IEEE802.11n-40)**

Equipment Type	Transceiver
Frequency of Operation	5190-5230MHz 5270-5310MHz 5510-5670MHz 5755-5795MHz
Type of Modulation	OFDM
Bandwidth & Channel spacing	40MHz & 40MHz
Antenna Type	SEMI-PIFA
Antenna Gain	-4.15dBi

**UL Japan, Inc.**

**Head Office EMC Lab.**

4383-326 Asama-cho, Ise-shi, Mie-ken 516-0021 JAPAN

Telephone : +81 596 24 8116

Facsimile : +81 596 24 8124

### GSM

Equipment Type	Transceiver
Frequency of Operation	[Up Link] GSM850: 824 – 849MHz PCS: 1850 – 1910MHz [Down Link] GSM850: 869 – 894MHz PCS: 1930 – 1990MHz
Type of Modulation	GMSK , 8PSK
Antenna Type	PIFA
Antenna Gain	GSM850: -5.86dBi PCS: -4.02dBi

### W-CDMA

Equipment Type	Transceiver
Frequency of Operation	[Up Link] Band V: 824 – 849MHz Band II: 1850 – 1910MHz [Down Link] Band V: 869 – 894MHz Band II: 1930 – 1990MHz
Type of Modulation	QPSK
Antenna Type	PIFA
Antenna Gain	Band V: -5.86dBi Band II: -4.02dBi

---

**UL Japan, Inc.**

**Head Office EMC Lab.**

4383-326 Asama-cho, Ise-shi, Mie-ken 516-0021 JAPAN

Telephone : +81 596 24 8116

Facsimile : +81 596 24 8124

### SECTION 3: Test specification, procedures & results

#### 3.1 Test Specification

Test Specification : FCC Part 15 Subpart C: 2011, final revised on July 8, 2011 and effective August 8, 2011

Title : FCC 47CFR Part15 Radio Frequency Device Subpart C Intentional Radiators  
Section 15.207 Conducted limits  
Section 15.247 Operation within the bands 902-928MHz,  
2400-2483.5MHz, and 5725-5850MHz

\* The EUT complies with FCC Part 15 Subpart B: 2011, final revised on July 8, 2011 and effective August 8, 2011

#### 3.2 Procedures and results

Item	Test Procedure	Specification	Worst Margin	Results	Remarks	
Conducted Emission	FCC: ANSI C63.4:2003 7. AC powerline conducted emission measurements IC: RSS-Gen 7.2.4	FCC: Section 15.207 ----- IC: RSS-Gen 7.2.4	QP 13.8dB, 26.22360MHz, N AV 21.3dB, 0.47931MHz, L	Complied	-	
Carrier Frequency Separation	FCC: FCC Public Notice DA 00-705 IC: -	FCC: Section15.247(a)(1) ----- IC: RSS-210 A8.1 (b)	See data.	Complied	Conducted	
20dB Bandwidth	FCC: FCC Public Notice DA 00-705 IC: -	FCC: Section15.247(a)(1) ----- IC: RSS-210 A8.1 (a)		-	Conducted	
Number of Hopping Frequency	FCC: FCC Public Notice DA 00-705 IC: -	FCC: Section15.247(a)(1)(iii) ----- IC: RSS-210 A8.1 (d)		Complied	Conducted	
Dwell time	FCC: FCC Public Notice DA 00-705 IC: -	FCC: Section15.247(a)(1)(iii) ----- IC: RSS-210 A8.1 (d)		Complied	Conducted	
Maximum Peak Output Power	FCC: FCC Public Notice DA 00-705 IC: RSS-Gen 4.8	FCC: Section15.247(a)(b)(1) ----- IC: RSS-210 A8.4 (2)		Complied	Conducted	
Spurious Emission & Band Edge Compliance	FCC: FCC Public Notice DA 00-705 IC: RSS-Gen 4.9	FCC: Section15.247(d) ----- IC: RSS-210 A8.5 RSS-Gen 6 and 7.2.3		4.3dB 41.449MHz, QP, Vert.	Complied	Conducted/ Radiated

Note: UL Japan, Inc.'s EMI Work Procedures No. 13-EM-W0420 and 13-EM-W0422.

\* In case any questions arise about test procedure, ANSI C63.4: 2003 is also referred.

### 3.3 Addition to standard

Item	Test Procedure	Specification	Worst margin	Results	Remarks
99% Occupied Bandwidth	IC: RSS-Gen 4.6.1	IC: RSS-Gen 4.6.1	N/A	-	Conducted

Other than above, no addition, exclusion nor deviation has been made from the standard.

### 3.4 Uncertainty

#### EMI

The following uncertainties have been calculated to provide a confidence level of 95% using a coverage factor k=2.

Test room (semi-anechoic chamber)	Conducted emission (+dB)
	150kHz-30MHz
No.1	3.5dB
No.2	3.6dB
No.3	3.6dB
No.4	3.6dB

Test room (semi-anechoic chamber)	Radiated emission						
	(3m*)(+dB)				(1m*)(+dB)		(0.5m*)(+dB)
	9kHz -30MHz	30MHz -300MHz	300MHz -1GHz	1GHz -10GHz	10GHz -18GHz	18GHz -26.5GHz	26.5GHz -40GHz
No.1	4.2dB	5.0dB	5.1dB	5.6dB	5.9dB	4.4dB	4.3dB
No.2	4.1dB	5.2dB	5.1dB	5.7dB	5.8dB	4.3dB	4.2dB
No.3	4.5dB	5.0dB	5.2dB	5.7dB	5.8dB	4.5dB	4.2dB
No.4	4.7dB	5.2dB	5.2dB	5.7dB	5.8dB	5.1dB	4.2dB

\*3m/1m/0.5m = Measurement distance

Power meter (+dB)	
Below 1GHz	Above 1GHz
1.0dB	1.0dB

Antenna terminal conducted emission and Power density (+dB)			Antenna terminal conducted emission (+dB)		Channel power (+dB)
Below 1GHz	1GHz-3GHz	3GHz-18GHz	18GHz-26.5GHz	26.5GHz-40GHz	
1.0dB	1.1dB	2.7dB	3.2dB	3.3dB	1.5dB

#### Conducted Emission test

The data listed in this test report has enough margin, more than the site margin.

#### Radiated emission test (3m)

The data listed in this report meets the limits unless the uncertainty is taken into consideration.

**UL Japan, Inc.**

**Head Office EMC Lab.**

4383-326 Asama-cho, Ise-shi, Mie-ken 516-0021 JAPAN

Telephone : +81 596 24 8116

Facsimile : +81 596 24 8124

### 3.5 Test Location

UL Japan, Inc. Head Office EMC Lab. \*NVLAP Lab. code: 200572-0  
4383-326 Asama-cho, Ise-shi, Mie-ken 516-0021 JAPAN  
Telephone : +81 596 24 8116 Facsimile : +81 596 24 8124

	FCC Registration Number	IC Registration Number	Width x Depth x Height (m)	Size of reference ground plane (m) / horizontal conducting plane	Other rooms
No.1 semi-anechoic chamber	313583	2973C-1	19.2 x 11.2 x 7.7m	7.0 x 6.0m	No.1 Power source room
No.2 semi-anechoic chamber	655103	2973C-2	7.5 x 5.8 x 5.2m	4.0 x 4.0m	-
No.3 semi-anechoic chamber	148738	2973C-3	12.0 x 8.5 x 5.9m	6.8 x 5.75m	No.3 Preparation room
No.3 shielded room	-	-	4.0 x 6.0 x 2.7m	N/A	-
No.4 semi-anechoic chamber	134570	2973C-4	12.0 x 8.5 x 5.9m	6.8 x 5.75m	No.4 Preparation room
No.4 shielded room	-	-	4.0 x 6.0 x 2.7m	N/A	-
No.5 semi-anechoic chamber	-	-	6.0 x 6.0 x 3.9m	6.0 x 6.0m	-
No.6 shielded room	-	-	4.0 x 4.5 x 2.7m	4.75 x 5.4 m	-
No.6 measurement room	-	-	4.75 x 5.4 x 3.0m	4.75 x 4.15 m	-
No.7 shielded room	-	-	4.7 x 7.5 x 2.7m	4.7 x 7.5m	-
No.8 measurement room	-	-	3.1 x 5.0 x 2.7m	N/A	-
No.9 measurement room	-	-	8.0 x 4.5 x 2.8m	2.0 x 2.0m	-
No.10 measurement room	-	-	2.6 x 2.8 x 2.5m	2.4 x 2.4m	-
No.11 measurement room	-	-	3.1 x 3.4 x 3.0m	2.4 x 3.4m	-

\* Size of vertical conducting plane (for Conducted Emission test) : 2.0 x 2.0m for No.1, No.2, No.3, and No.4 semi-anechoic chambers and No.3 and No.4 shielded rooms.

### 3.6 Data of EMI, Test instruments, and Test set up

Refer to APPENDIX.

## **SECTION 4: Operation of E.U.T. during testing**

### **4.1 Operating Mode(s)**

Bluetooth (BT): Transmitting (Tx), Payload: PRBS9  
Inquiry

Details of Operating Mode(s)

<b>Test Item</b>	<b>Mode</b>	<b>Tested frequency</b>
Conducted Emission, Spurious Emission (Conducted/Radiated)	Tx (Hopping off) DH5, 3DH5	2402MHz 2441MHz 2480MHz
Carrier Frequency Separation 20dB Bandwidth	Tx (Hopping on) DH5, 3DH5 Inquiry	2402MHz 2441MHz 2480MHz
Number of Hopping Frequency	Tx (Hopping on) DH5, 3DH5 Inquiry	-
Dwell time	Tx (Hopping on), -DH1, DH3, DH5 -3DH1, 3DH3, 3DH5 Inquiry	-
Maximum Peak Output Power	Tx (Hopping off) DH5, 3DH5 Inquiry	2402MHz 2441MHz 2480MHz
Band Edge Compliance (Conducted)	Tx DH5, 3DH5 -Hopping on -Hopping off	2402MHz 2480MHz
99% Occupied Bandwidth	Tx DH5, 3DH5 -Hopping on -Hopping off	2402MHz 2441MHz 2480MHz
<p>*As a result of preliminary test, the formal test was performed with the above modes, which had the maximum payload length (except Dwell time test)  *The EUT support AFH with a minimum of 20 channels, following the Bluetooth protocol to ensure compliance with the pseudo-hopping sequence and dwell time requirements of FCC 15.247.</p>		

**\*Power of the EUT was set by the software as follows:**

Power settings: Maximum power of the EUT was transmitted on Bluetooth testing mode.  
Software: HW: Rev. 1.0, SW: P6200L.010

This setting of software is the worst case.

Any conditions under the normal use do not exceed the condition of setting.

In addition, end users cannot change the settings of the output power of the product.

**UL Japan, Inc.**

**Head Office EMC Lab.**

4383-326 Asama-cho, Ise-shi, Mie-ken 516-0021 JAPAN

Telephone : +81 596 24 8116

Facsimile : +81 596 24 8124

## 4.2 Configuration and peripherals

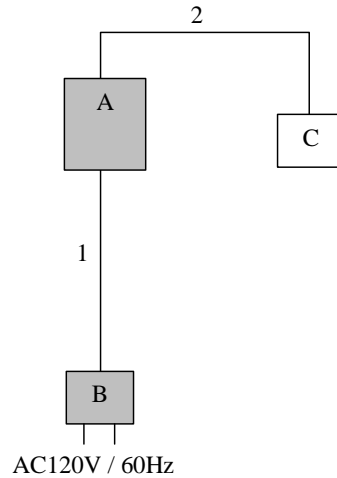

\* Cabling and setup(s) were taken into consideration and test data was taken under worse case conditions.

### Description of EUT and Support equipment

No.	Item	Model number	Serial number	Manufacturer	Remarks
A	Cellular/PCS GSM/GPRS/EDGE, Cellular /PCS WCDMA Tablet with 802.11abgn, BT3.0	GT-P6200L	R2DB815121V *1) R2DB815125K *2)	SAMSUNG	EUT
B	AC Adapter	ETA-P11X	-	SAMSUNG	EUT
C	Ear phone	-	-	SAMSUNG	-

\*1) Used for Antenna Terminal conducted test

\*2) Used for Conducted Emission and Radiated Emission tests

### List of cables used

No.	Name	Length (m)	Shield		Remarks
			Cable	Connector	
1	USB Cable	1.0	Shielded	Shielded	-
2	Ear phone Cable	1.2	Unshielded	Unshielded	-

**UL Japan, Inc.**

**Head Office EMC Lab.**

4383-326 Asama-cho, Ise-shi, Mie-ken 516-0021 JAPAN

Telephone : +81 596 24 8116

Facsimile : +81 596 24 8124

## **SECTION 5: Conducted Emission**

### **Test Procedure and conditions**

EUT was placed on a urethane platform of nominal size, 1.0m by 0.5m, raised 0.8m above the conducting ground plane. The rear of tabletop was located 40cm to the vertical conducting plane. The rear of EUT, including peripherals aligned and flushed with rear of tabletop. All other surfaces of tabletop were at least 80cm from any other grounded conducting surface. EUT was located 80cm from a Line Impedance Stabilization Network (LISN)/ Artificial mains Network (AMN) and excess AC cable was bundled in center.

#### For the tests on EUT with other peripherals (as a whole system)

I/O cables that were connected to the peripherals were bundled in center. They were folded back and forth forming a bundle 30cm to 40cm long and were hanged at a 40cm height to the ground plane. All unused 50ohm connectors of the LISN(AMN) were resistivity terminated in 50ohm when not connected to the measuring equipment.

The AC Mains Terminal Continuous disturbance Voltage has been measured with the EUT in a Semi Anechoic Chamber.

The EUT was connected to a LISN (AMN).

An overview sweep with peak detection has been performed.

The test results and limit are rounded off to one decimal place, so some differences might be observed.

<b>Detector</b>	<b>: QP and AV</b>
<b>Measurement range</b>	<b>: 0.15-30MHz</b>
<b>Test data</b>	<b>: APPENDIX</b>
<b>Test result</b>	<b>: Pass</b>

---

**UL Japan, Inc.**

**Head Office EMC Lab.**

4383-326 Asama-cho, Ise-shi, Mie-ken 516-0021 JAPAN

Telephone : +81 596 24 8116

Facsimile : +81 596 24 8124

## **SECTION 6: Radiated Spurious Emission**

### **Test Procedure**

EUT was placed on a urethane platform of nominal size, 1.0m by 0.5m, raised 0.8m above the conducting ground plane. The Radiated Electric Field Strength has been measured in a Semi Anechoic Chamber with a ground plane.

The height of the measuring antenna varied between 1 and 4m and EUT was rotated a full revolution in order to obtain the maximum value of the electric field strength.

The measurements were performed for both vertical and horizontal antenna polarization with the Test Receiver, or the Spectrum Analyzer.

The measurements were made with the following detector function of the test receiver and the Spectrum analyzer (in linear mode).

The test was made with the detector (RBW/VBW) in the following table.

When using Spectrum analyzer, the test was made with adjusting span to zero by using peak hold.

### **Test Antennas are used as below;**

Frequency	Below 30MHz	30MHz to 300MHz	300MHz to 1GHz	Above 1GHz
Antenna Type	Loop	Biconical	Logperiodic	Horn

In any 100kHz bandwidth outside the restricted band in which the spread spectrum intentional radiator is operating, the radio frequency power that is produced by the intentional radiator confirmed 20dB below that in the 100kHz bandwidth within the band that contains the highest level of the desired power, based on a radiated measurement.

### **20dBc was applied to the frequency over the limit of FCC 15.209 / Table 5 of RSS-Gen 7.2.5 (IC) and outside the restricted band of FCC15.205 / Table 3 of RSS-Gen 7.2.2 (IC).**

Frequency	Below 1GHz	Above 1GHz		20dBc
Instrument used	Test Receiver	Spectrum Analyzer *1)		Spectrum Analyzer *1)
Detector	QP	PK	AV	PK
IF Bandwidth	BW 120kHz(T/R)	RBW: 1MHz VBW: 3MHz	RBW: 1MHz VBW: 10Hz	RBW: 100kHz VBW: 300kHz (S/A)
Test Distance	3m	3m (below 10GHz), 1m*2) (above 10GHz)		3m (below 10GHz), 1m*2) (above 10GHz)

\*1) The Spectrum Analyzer was used in 3dB resolution bandwidth.

\*2) Distance Factor:  $20 \times \log(3.0\text{m}/1.0\text{m}) = 9.5\text{dB}$

- The carrier level and noise levels were confirmed at each position of X, Y and Z axes of EUT to see the position of maximum noise, and the test was made at the position that has the maximum noise.

The test results and limit are rounded off to one decimal place, so some differences might be observed.

**Measurement range** : 30M-25GHz  
**Test data** : APPENDIX  
**Test result** : Pass

**UL Japan, Inc.**

**Head Office EMC Lab.**

4383-326 Asama-cho, Ise-shi, Mie-ken 516-0021 JAPAN

Telephone : +81 596 24 8116

Facsimile : +81 596 24 8124

## **SECTION 7: Antenna Terminal Conducted Tests**

### **Test Procedure**

The tests were made with below setting connected to the antenna port.

<b>Test</b>	<b>Span</b>	<b>RBW</b>	<b>VBW</b>	<b>Sweep time</b>	<b>Detector</b>	<b>Trace</b>	<b>Instrument used</b>
20dB Bandwidth	3MHz	30kHz	100kHz	Auto	Peak	Max Hold	Spectrum Analyzer
99% Occupied Bandwidth	Enough width to display 20dB Bandwidth	1 to 3% of Span	Three times of RBW	Auto	Peak	Max Hold	Spectrum Analyzer
Maximum Peak Output Power	-	-	-	Auto	Peak	-	Power Meter (Sensor: 50MHz BW)
Carrier Frequency Separation	3MHz	30kHz	100kHz	Auto	Peak	Max Hold	Spectrum Analyzer
Number of Hopping Frequency	30MHz	300kHz	1MHz	Auto	Peak	Max Hold	Spectrum Analyzer
Dwell Time	Zero Span	100kHz, 1MHz	300kHz, 3MHz	As necessary capture the entire dwell time per hopping channel	Peak	Max Hold	Spectrum Analyzer
Conducted Spurious Emission *1)	9kHz to 150kHz	200Hz	620Hz	Auto	Peak	Max Hold	Spectrum Analyzer
	150kHz to 30MHz	9.1kHz	27kHz				
	30MHz to 25GHz (Less or equal to 5GHz)	100kHz	300kHz				
Conducted Spurious Emission Band Edge compliance	20MHz	300kHz	1MHz	Auto	Peak	Max Hold	Spectrum Analyzer

\*1) In the frequency range below 30MHz, RBW was narrowed to separate the noise contents. Then, wide-band noise near the limit was checked separately, however the noise was not detected as shown in the chart.(9kHz-150kHz:RBW=200Hz, 150kHz-30MHz:RBW=9.1kHz)

The test results and limit are rounded off to two decimals place, so some differences might be observed.

**Test data** : APPENDIX  
**Test result** : Pass

**APPENDIX 1: Data of EMI test**

**Conducted Emission**

**DATA OF CONDUCTED EMISSION TEST**

UL Japan, Inc. Head Office EMC Lab. No. 2 Semi Anechoic Chamber  
Date : 2011/10/06

Report No. : 32BE0278-H0

Temp./Humi. : 24deg. C / 52%RH  
Engineer : Hisayoshi Sato

Mode / Remarks : Tx BT 2441MHz DH5

LIMIT : FCC15.207 QP  
FCC15.207 AV

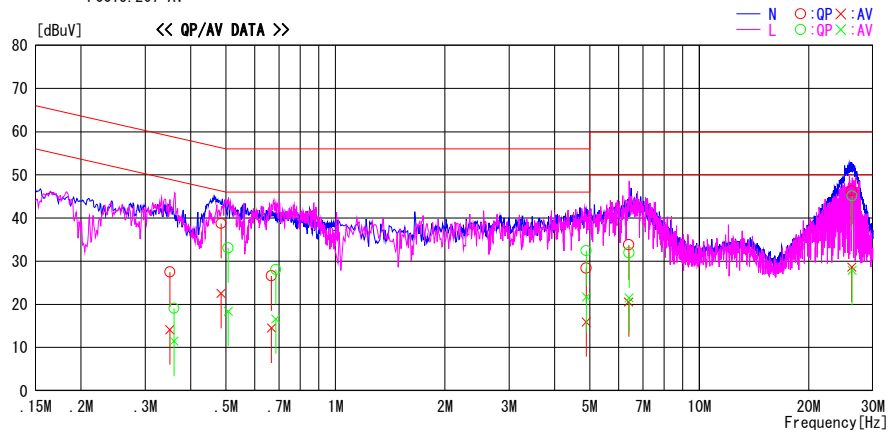

Frequency [MHz]	Reading Level		Corr. Factor [dB]	Results		Limit		Margin		Phase	Comment
	QP [dBuV]	AV [dBuV]		QP [dBuV]	AV [dBuV]	QP [dBuV]	AV [dBuV]	QP [dB]	AV [dB]		
0.35043	14.2	0.8	13.3	27.5	14.1	59.0	49.0	31.5	34.9	N	
0.48491	25.4	9.2	13.3	38.7	22.5	56.3	46.3	17.6	23.8	N	
0.66688	13.1	1.0	13.5	26.6	14.5	56.0	46.0	29.4	31.5	N	
4.88728	13.9	1.4	14.5	28.4	15.9	56.0	46.0	27.6	30.1	N	
6.39265	19.1	5.8	14.7	33.8	20.5	60.0	50.0	26.2	29.5	N	
26.22360	27.9	10.3	18.3	46.2	28.6	60.0	50.0	13.8	21.4	N	
0.35982	5.8	-1.9	13.3	19.1	11.4	58.7	48.7	39.6	37.3	L	
0.50708	19.8	5.1	13.3	33.1	18.4	56.0	46.0	22.9	27.6	L	
0.68592	14.6	3.1	13.5	28.1	16.6	56.0	46.0	27.9	29.4	L	
4.89045	17.9	7.2	14.5	32.4	21.7	56.0	46.0	23.6	24.3	L	
6.41300	17.2	6.8	14.7	31.9	21.5	60.0	50.0	28.1	28.5	L	
26.29780	26.8	9.5	18.3	45.1	27.8	60.0	50.0	14.9	22.2	L	

CHART: WITH FACTOR, Peak hold data. CALCULATION: RESULT=READING+C.F.(LISN LOSS + ATT LOSS + CABLE LOSS)  
Except for the above table : adequate margin data below the limits.

## Conducted Emission

Test place	Head Office EMC Lab. No.2 Semi Anechoic Chamber
Report No.	32BE0278-HO
Date	10/06/2011
Temperature/ Humidity	24 deg.C/ 52% RH
Engineer	Hisayoshi Sato
Mode	Tx DH5

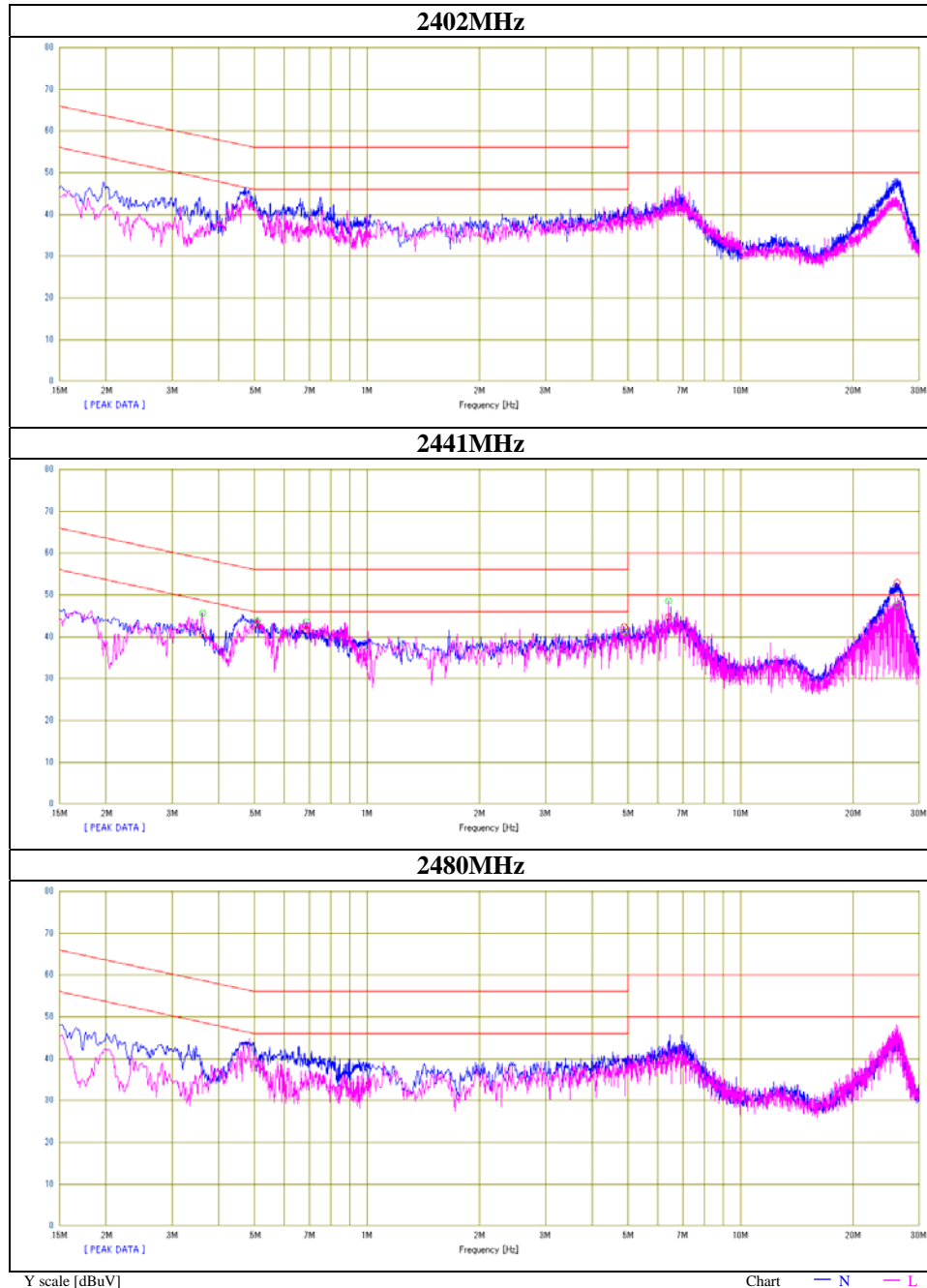

## Conducted Emission

### DATA OF CONDUCTED EMISSION TEST

UL Japan, Inc. Head Office EMC Lab. No. 2 Semi Anechoic Chamber  
Date : 2011/10/06

Report No. : 32BE0278-HO  
Temp./Humi. : 24deg. C / 52%RH  
Engineer : Hisayoshi Sato

Mode / Remarks : Tx BT 2441MHz 3DH5

LIMIT : FCC15.207 QP  
FCC15.207 AV

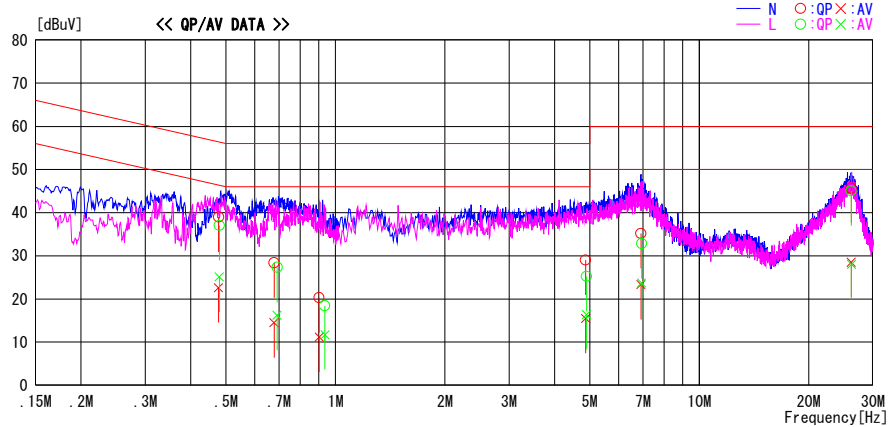

Frequency [MHz]	Reading Level		Corr. Factor [dB]	Results		Limit		Margin		Phase	Comment
	QP [dBuV]	AV [dBuV]		QP [dBuV]	AV [dBuV]	QP [dBuV]	AV [dBuV]	QP [dB]	AV [dB]		
0.47733	25.7	9.3	13.3	39.0	22.6	56.4	46.4	17.4	23.8	N	
0.67780	14.9	1.0	13.5	28.4	14.5	56.0	46.0	27.6	31.5	N	
0.90238	6.8	-2.3	13.5	20.3	11.2	56.0	46.0	35.7	34.8	N	
4.87060	14.5	1.0	14.5	29.0	15.5	56.0	46.0	27.0	30.5	N	
6.90712	20.4	8.5	14.8	35.2	23.3	60.0	50.0	24.8	26.7	N	
26.13050	27.4	10.2	18.3	45.7	28.5	60.0	50.0	14.3	21.5	N	
0.47931	23.7	11.8	13.3	37.0	25.1	56.4	46.4	19.4	21.3	L	
0.69130	13.8	2.7	13.5	27.3	16.2	56.0	46.0	28.7	29.8	L	
0.93460	4.9	-1.8	13.5	18.4	11.7	56.0	46.0	37.6	34.3	L	
4.89921	10.7	1.9	14.5	25.2	16.4	56.0	46.0	30.8	29.6	L	
6.94151	18.0	8.9	14.8	32.8	23.7	60.0	50.0	27.2	26.3	L	
26.15960	26.7	9.7	18.3	45.0	28.0	60.0	50.0	15.0	22.0	L	

CHART: WITH FACTOR, Peak hold data. CALCULATION: RESULT=READING+C.F (LISN LOSS + ATT LOSS + CABLE LOSS)  
Except for the above table : adequate margin data below the limits.

## Conducted Emission

Test place	Head Office EMC Lab. No.2 Semi Anechoic Chamber
Report No.	32BE0278-HO
Date	10/06/2011
Temperature/ Humidity	24 deg.C/ 52% RH
Engineer	Hisayoshi Sato
Mode	Tx 3DH5

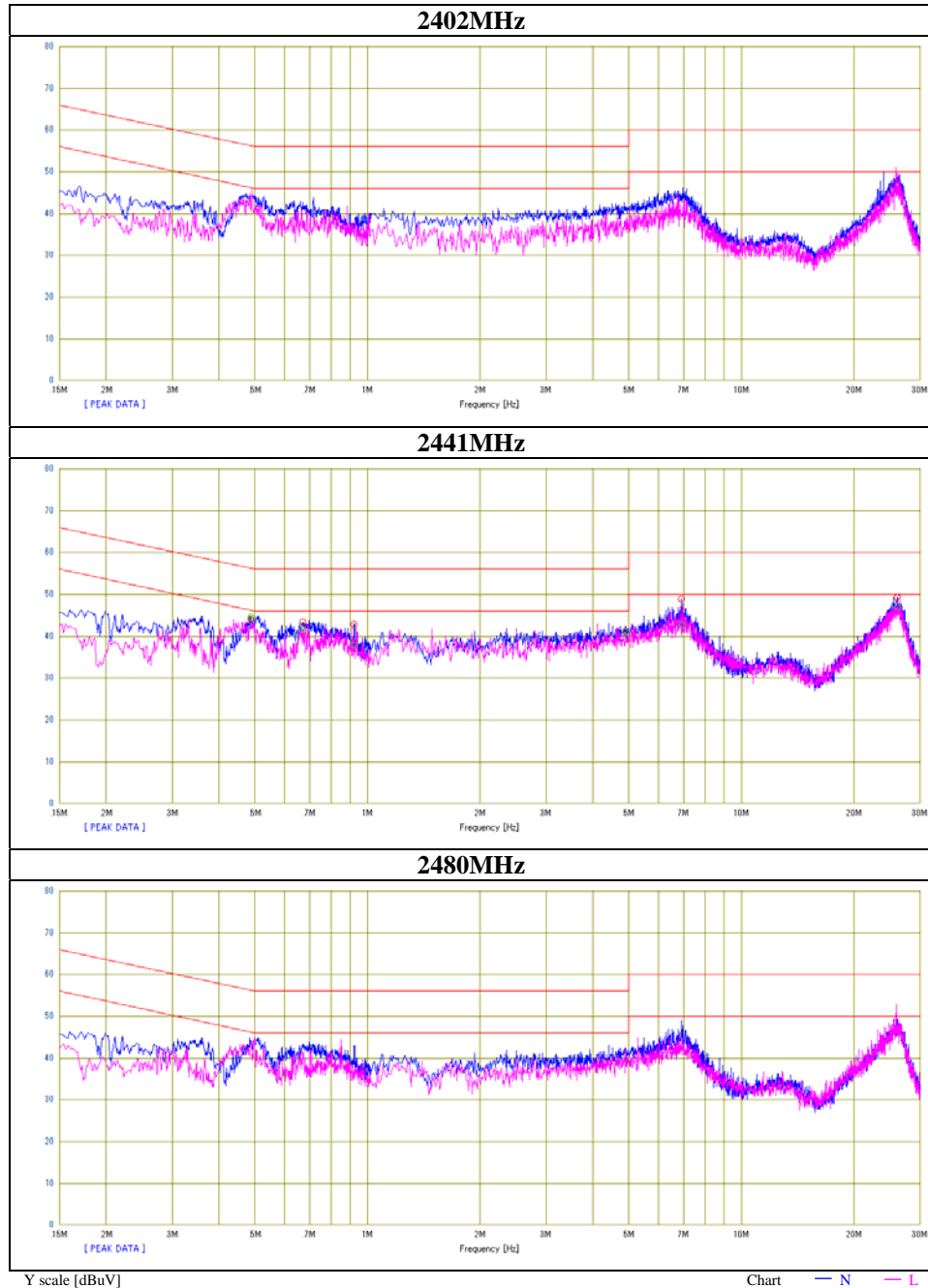

## 20dB Bandwidth and Carrier Frequency Separation

Test place	Head Office EMC Lab. No.7 Shielded Room
Report No.	32BE0278-HO
Date	10/07/2011
Temperature/ Humidity	25 deg.C/ 44% RH
Engineer	Takayuki Shimada
Mode	Tx (Hopping on) DH5/3DH5/Inquiry

Mode	Freq. [MHz]	20dB Bandwidth [MHz]	Carrier Frequency Separation [MHz]	Limit for Carrier Frequency separation [MHz]
DH5	2402.0	0.959	1.000	>= 0.639
DH5	2441.0	0.954	1.000	>= 0.636
DH5	2480.0	0.955	1.000	>= 0.637
3DH5	2402.0	1.281	1.000	>= 0.854
3DH5	2441.0	1.288	1.000	>= 0.859
3DH5	2480.0	1.283	1.000	>= 0.855
Inquiry	2441.0	0.829	2.000	>= 0.552

Limit: Two-thirds of 20dB Bandwidth or 25kHz (whichever is greater).  
No limit applies to 20dB Bandwidth.

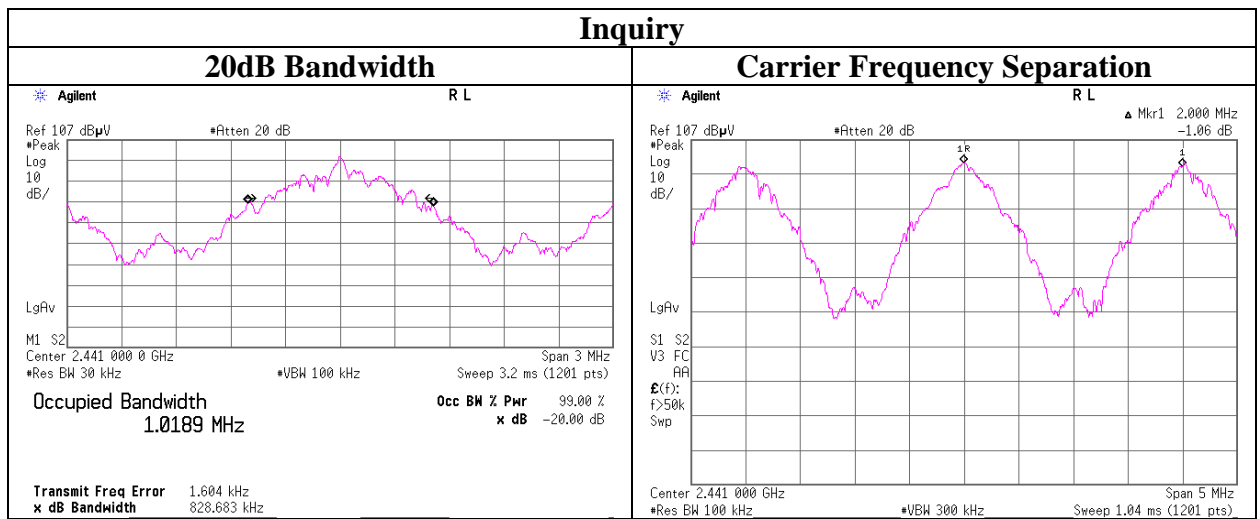

**20dB Bandwidth and Carrier Frequency Separation**

<b>Tx DH5</b>	
<b>20dB Bandwidth</b>	<b>Carrier Frequency Separation</b>
<b>2402MHz</b>	<b>2402MHz</b>
<p>Agilent R L</p> <p>Ref 107 dBµV *Atten 20 dB</p> <p>Occupied Bandwidth 885.6773 kHz</p> <p>Transmit Freq Error 15.669 kHz x dB Bandwidth 958.894 kHz</p>	<p>Agilent R L</p> <p>Ref 107 dBµV *Atten 20 dB</p> <p>Carrier Freq Separation 1.000 MHz</p>
<b>2441MHz</b>	<b>2441MHz</b>
<p>Agilent R L</p> <p>Ref 107 dBµV *Atten 20 dB</p> <p>Occupied Bandwidth 880.0415 kHz</p> <p>Transmit Freq Error 5.119 kHz x dB Bandwidth 954.130 kHz</p>	<p>Agilent R L</p> <p>Ref 107 dBµV *Atten 20 dB</p> <p>Carrier Freq Separation 1.000 MHz</p>
<b>2480MHz</b>	<b>2480MHz</b>
<p>Agilent R L</p> <p>Ref 107 dBµV *Atten 20 dB</p> <p>Occupied Bandwidth 876.9158 kHz</p> <p>Transmit Freq Error 3.742 kHz x dB Bandwidth 954.963 kHz</p>	<p>Agilent R L</p> <p>Ref 107 dBµV *Atten 20 dB</p> <p>Carrier Freq Separation 1.000 MHz</p>

**20dB Bandwidth and Carrier Frequency Separation**

Tx 3DH5	
20dB Bandwidth	Carrier Frequency Separation
<b>2402MHz</b>	<b>2402MHz</b>
<b>2441MHz</b>	<b>2441MHz</b>
<b>2480MHz</b>	<b>2480MHz</b>

## Number of Hopping Frequency

Test place	Head Office EMC Lab. No.7 Shielded Room
Report No.	32BE0278-HO
Date	10/07/2011
Temperature/ Humidity	25 deg.C/ 44% RH
Engineer	Takayuki Shimada
Mode	Tx (Hopping on) DH5/3DH5/Inquiry

Mode	Number of channel [times]	Limit [times]
DH5	79	>= 15
3DH5	79	>= 15
Inquiry	32	>= 15

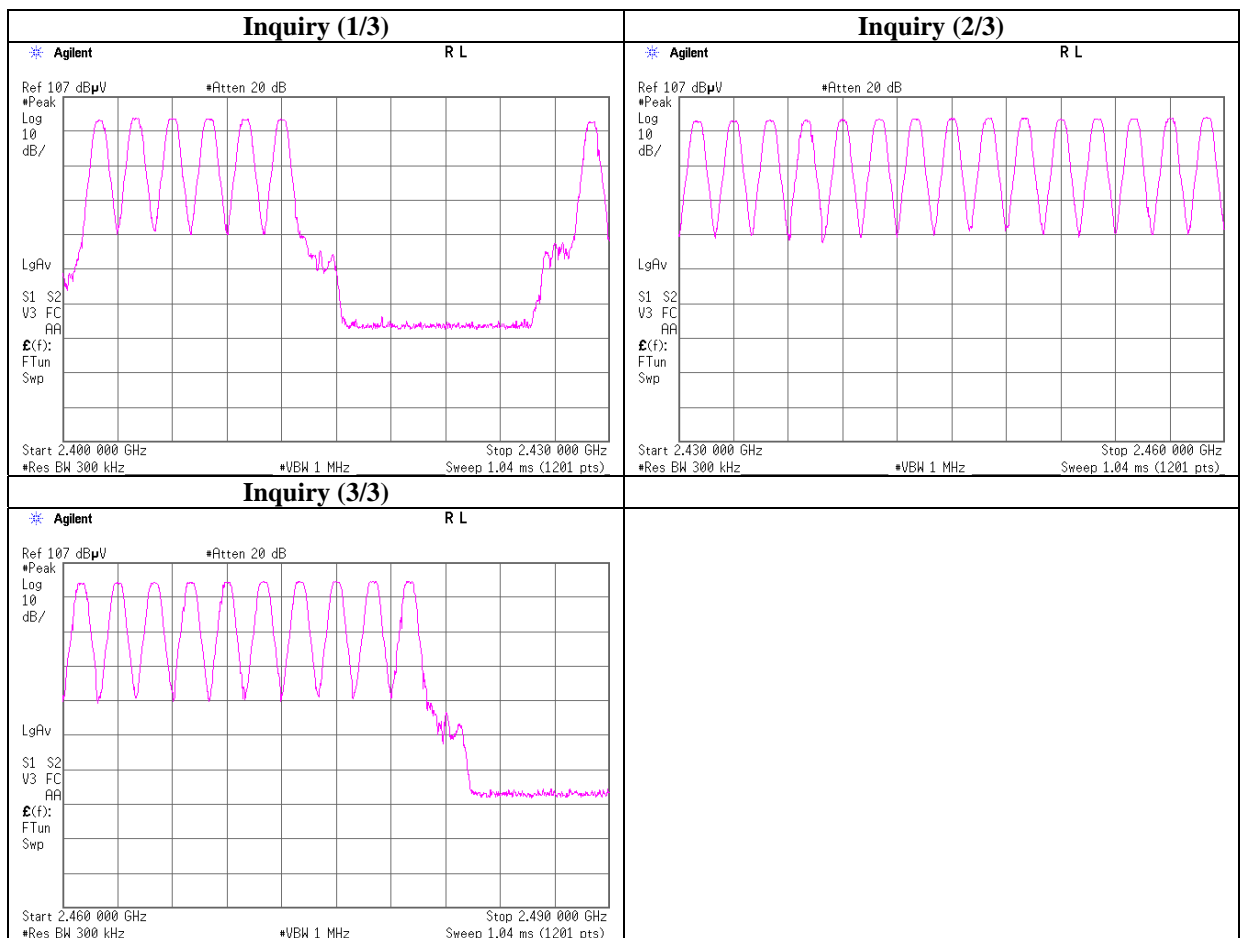

### Number of Hopping Frequency

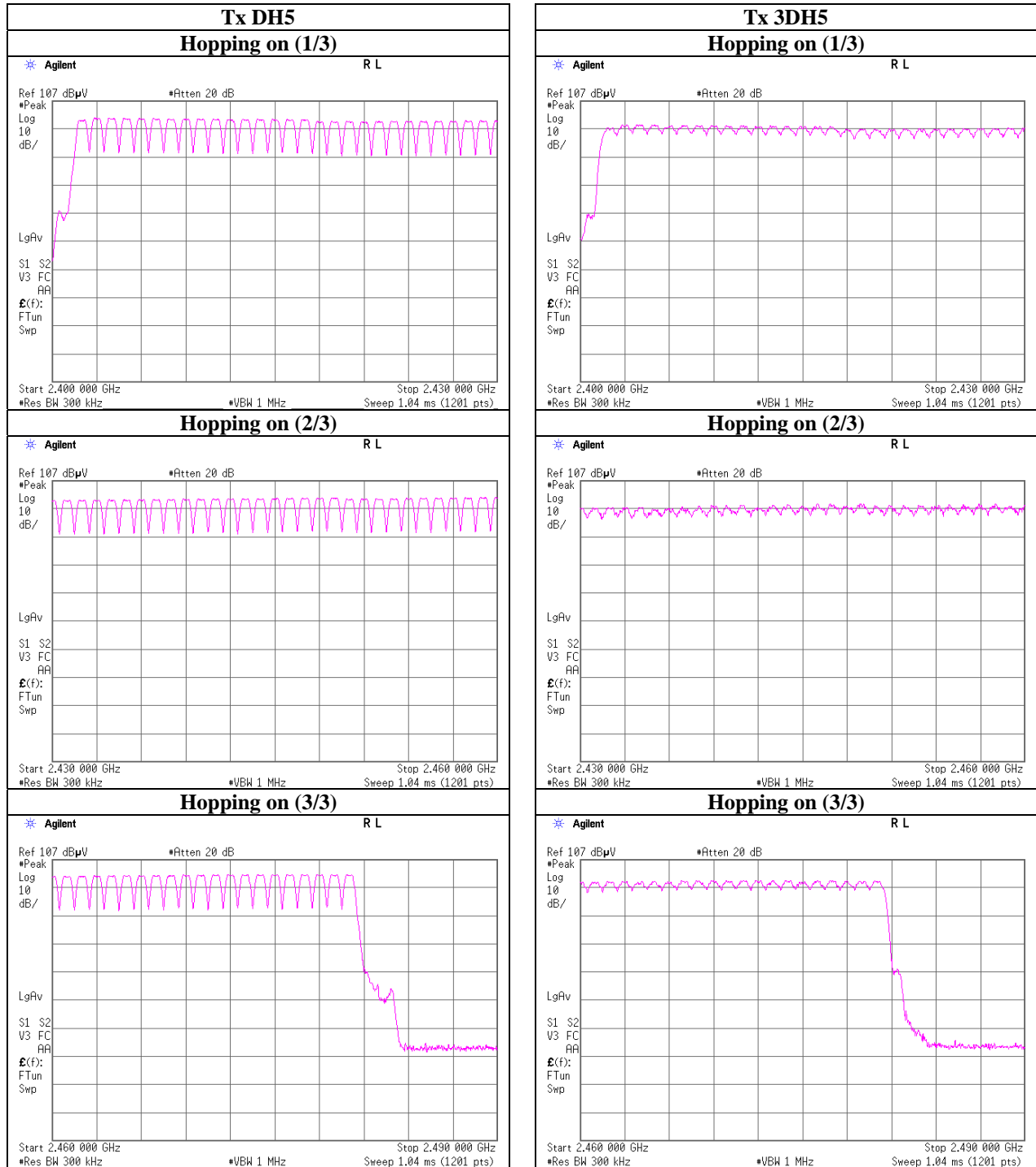

## Dwell time

Test place	Head Office EMC Lab. No.7 Shielded Room
Report No.	32BE0278-HO
Date	10/07/2011
Temperature/ Humidity	25 deg.C/ 44% RH
Engineer	Takayuki Shimada
Mode	Tx (Hopping on) DH5/3DH5/Inquiry

Mode	Number of transmission in a 31.6(79 Hopping x 0.4) / 12.8(32 Hopping x 0.4)second period		Length of transmission time [msec]	Result [msec]	Limit [msec]
DH1	49.4 times / 5 sec. x	31.6 sec. =	313 times	0.430	400
DH3	25.2 times / 5 sec. x	31.6 sec. =	160 times	1.692	400
DH5	18.2 times / 5 sec. x	31.6 sec. =	116 times	2.953	400
3DH1	48.6 times / 5 sec. x	31.6 sec. =	308 times	0.444	400
3DH3	25.0 times / 5 sec. x	31.6 sec. =	158 times	1.695	400
3DH5	18.8 times / 5 sec. x	31.6 sec. =	119 times	2.948	400
Inquiry	100.0 times / 1 sec. x	12.8 sec. =	1280 times	0.130	400

Sample Calculation

Result = Number of transmission x Length of transmission time

\*Average data of 5 tests.(except Inquiry)

Mode	Sampling [times]					Average [times]
	1	2	3	4	5	
DH1	50	47	51	49	50	49.4
DH3	27	23	26	25	25	25.2
DH5	19	18	18	18	18	18.2
3DH1	49	49	47	48	50	48.6
3DH3	25	25	28	21	26	25.0
3DH5	20	18	18	21	17	18.8

Sample Calculation

Average= Summation(Sampling 1 to 5) / 5

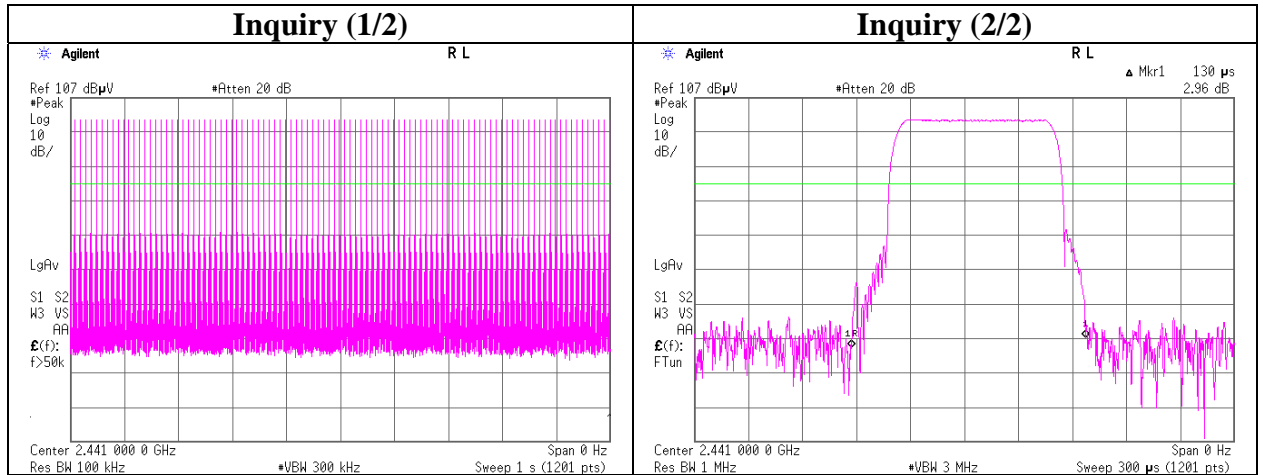

**UL Japan, Inc.**

**Head Office EMC Lab.**

4383-326 Asama-cho, Ise-shi, Mie-ken 516-0021 JAPAN

Telephone : +81 596 24 8116

Facsimile : +81 596 24 8124

**Dwell time**

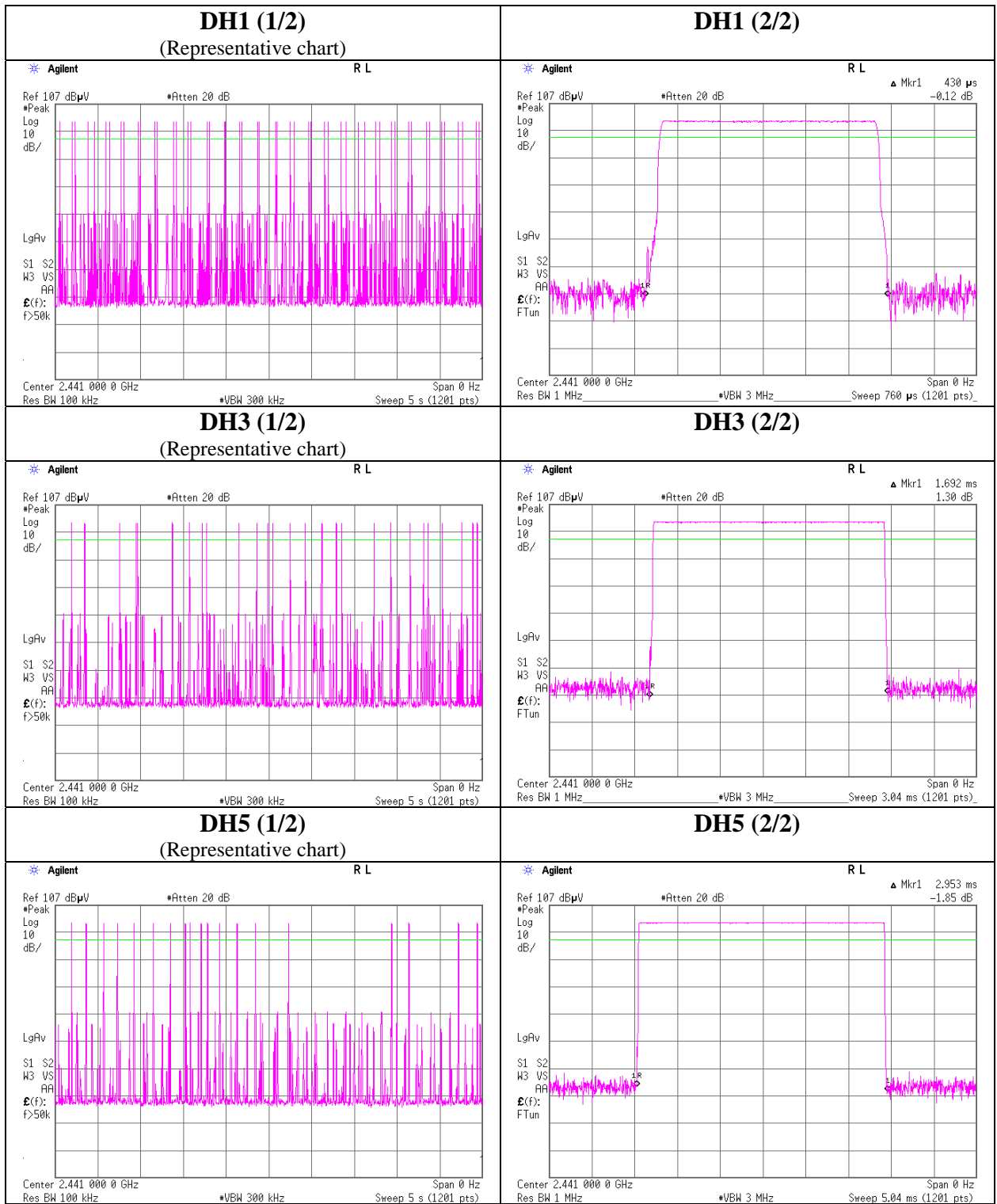

**Dwell time**

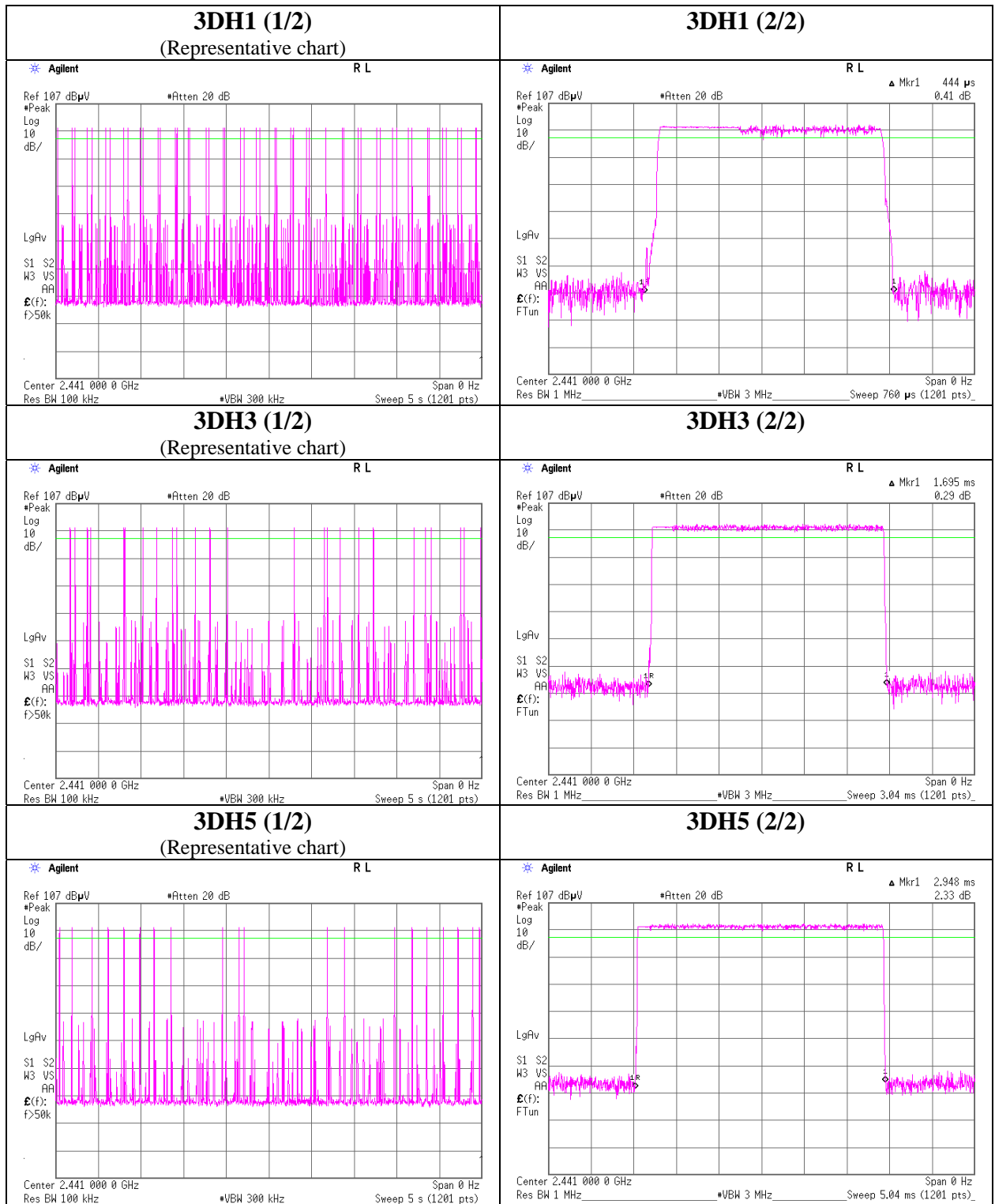









## Radiated Spurious Emission

Test place Head Office EMC Lab. No.2 Semi Anechoic Chamber  
Report No. 32BE0278-HO  
Date 10/04/2011  
Temperature/ Humidity 23 deg.C/ 57% RH  
Engineer Takumi Shimada  
Mode Tx, 3DH5 2402MHz

Polarity	Frequency [MHz]	Detector	Reading [dBuV]	Ant.Fac. [dB/m]	Loss [dB]	Gain [dB]	Result [dBuV/m]	Limit [dBuV/m]	Margin [dB]	Remark
Hori	41.460	QP	30.6	14.1	6.9	28.6	23.0	40.0	17.0	
Hori	106.652	QP	29.5	11.1	7.5	28.4	19.7	43.5	23.8	
Hori	160.001	QP	29.4	15.5	7.9	28.1	24.7	43.5	18.8	
Hori	320.003	QP	31.9	14.7	8.9	27.8	27.7	46.0	18.3	
Hori	372.342	QP	33.1	16.4	9.2	28.1	30.6	46.0	15.4	
Hori	426.659	QP	29.3	17.5	9.4	28.4	27.8	46.0	18.2	
Hori	2390.000	PK	42.3	27.4	2.2	32.4	39.5	73.9	34.4	
Hori	2400.000	PK	68.4	27.4	2.2	32.4	65.6	-	-	See 20dBc Data Sheet
Hori	4804.000	PK	42.1	31.3	4.8	31.6	46.6	73.9	27.3	
Hori	7206.000	PK	42.3	35.5	5.6	31.5	51.9	73.9	22.0	
Hori	9608.000	PK	42.1	38.4	6.3	31.9	54.9	73.9	19.0	
Hori	24020.000	PK	46.0	40.5	-1.7	30.5	54.3	73.9	19.6	
Hori	2390.000	AV	30.3	27.4	2.2	32.4	27.5	53.9	26.4	
Hori	2400.000	AV	52.3	27.4	2.2	32.4	49.5	-	-	See 20dBc Data Sheet
Hori	4804.000	AV	30.3	31.3	4.8	31.6	34.8	53.9	19.1	
Hori	7206.000	AV	29.9	35.5	5.6	31.5	39.5	53.9	14.4	
Hori	9608.000	AV	29.9	38.4	6.3	31.9	42.7	53.9	11.2	
Hori	24020.000	AV	34.8	40.5	-1.7	30.5	43.1	53.9	10.8	
Vert	41.593	QP	43.1	14.1	6.9	28.6	35.5	40.0	4.5	
Vert	106.010	QP	26.6	11.0	7.5	28.4	16.7	43.5	26.8	
Vert	106.649	QP	28.6	11.1	7.5	28.4	18.8	43.5	24.7	
Vert	320.001	QP	29.4	14.7	8.9	27.8	25.2	46.0	20.8	
Vert	373.343	QP	30.7	16.4	9.2	28.1	28.2	46.0	17.8	
Vert	426.661	QP	28.6	17.5	9.4	28.4	27.1	46.0	18.9	
Vert	2390.000	PK	44.5	27.4	2.2	32.4	41.7	73.9	32.2	
Vert	2400.000	PK	69.0	27.4	2.2	32.4	66.2	-	-	See 20dBc Data Sheet
Vert	4804.000	PK	41.4	31.3	4.8	31.6	45.9	73.9	28.0	
Vert	7206.000	PK	42.1	35.5	5.6	31.5	51.7	73.9	22.2	
Vert	9608.000	PK	42.5	38.4	6.3	31.9	55.3	73.9	18.6	
Vert	24020.000	PK	46.4	40.5	-1.7	30.5	54.7	73.9	19.2	
Vert	2390.000	AV	30.4	27.4	2.2	32.4	27.6	53.9	26.3	
Vert	2400.000	AV	53.7	27.4	2.2	32.4	50.9	-	-	See 20dBc Data Sheet
Vert	4804.000	AV	30.2	31.3	4.8	31.6	34.7	53.9	19.2	
Vert	7206.000	AV	29.6	35.5	5.6	31.5	39.2	53.9	14.7	
Vert	9608.000	AV	29.7	38.4	6.3	31.9	42.5	53.9	11.4	
Vert	24020.000	AV	34.7	40.5	-1.7	30.5	43.0	53.9	10.9	

Result = Reading + Ant Factor + Loss (Cable+Attenuator+Filter-Distance factor(above 10GHz)) - Gain(Amplifier)

\*Other frequency noises omitted in this report were not seen or had enough margin (more than 20dB).

\*The 10th harmonic was not seen so the result was its base noise level.

Distance factor: 10GHz-26.5GHz 20log(3.0m/1.0m)= 9.5dB  
26.5GHz-40GHz 20log(3.0m/0.5m)=15.6dB







## Conducted Spurious Emission

### Tx DH5 2402MHz

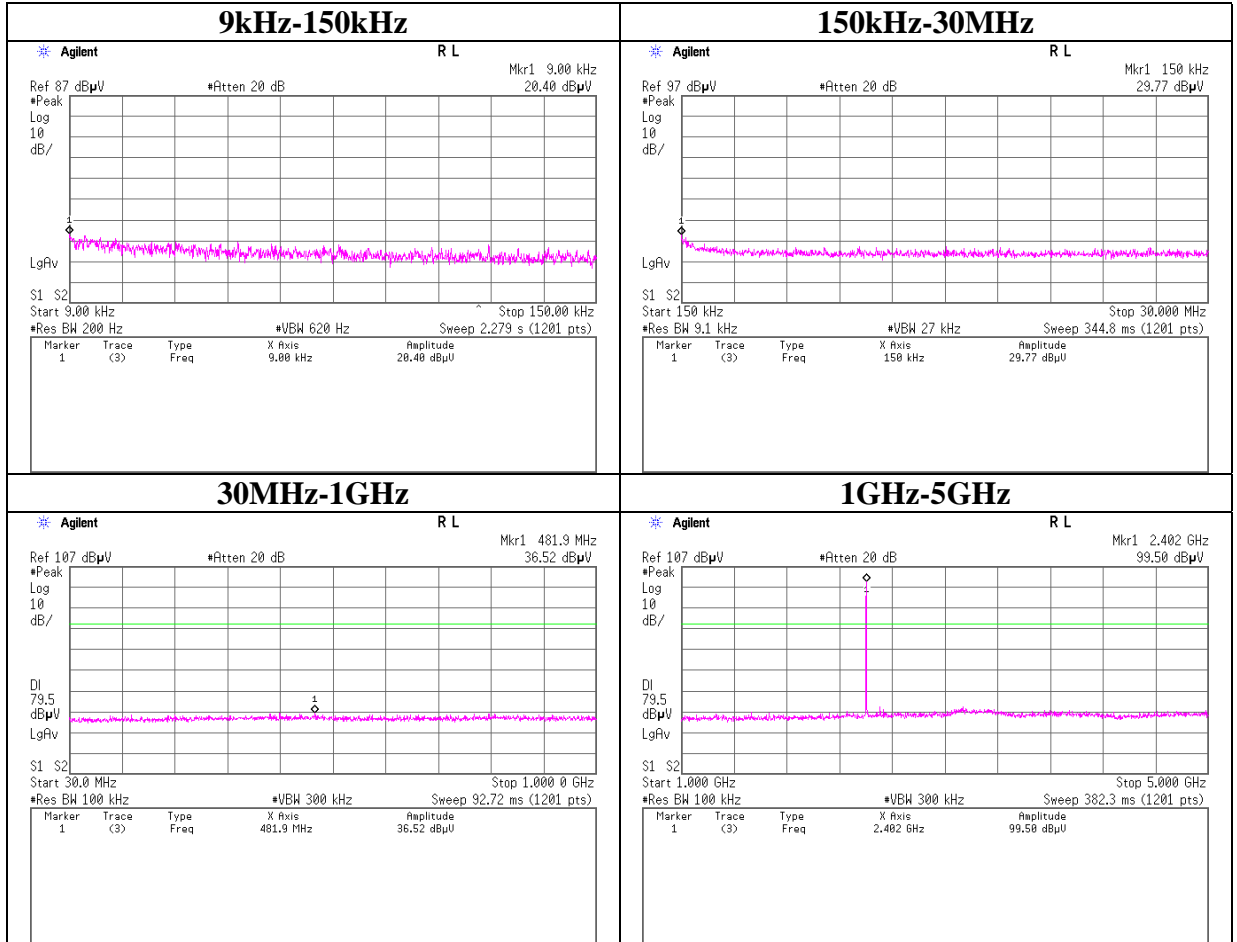

## Conducted Spurious Emission

### Tx DH5 2402MHz

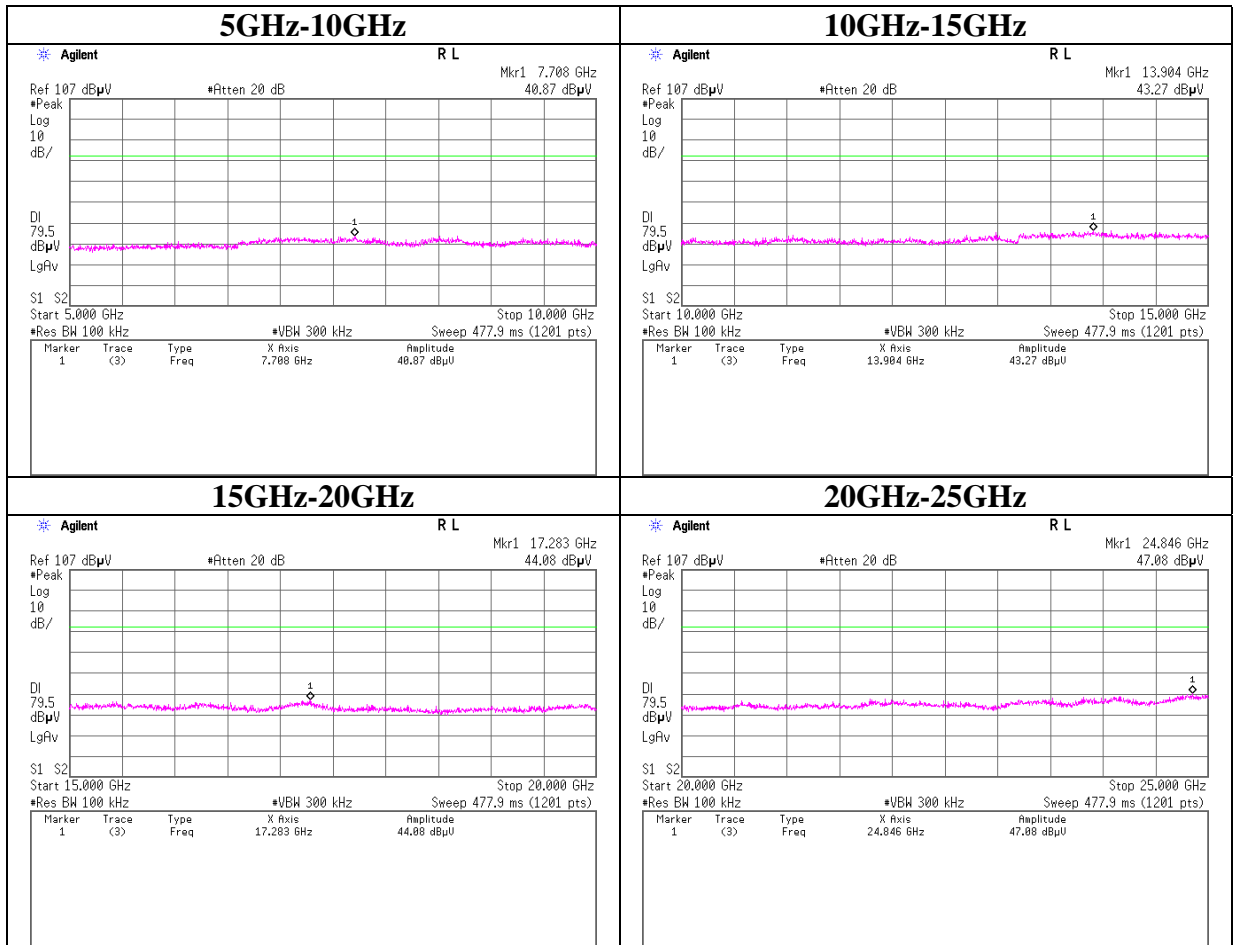

## Conducted Spurious Emission

### Tx DH5 2441MHz

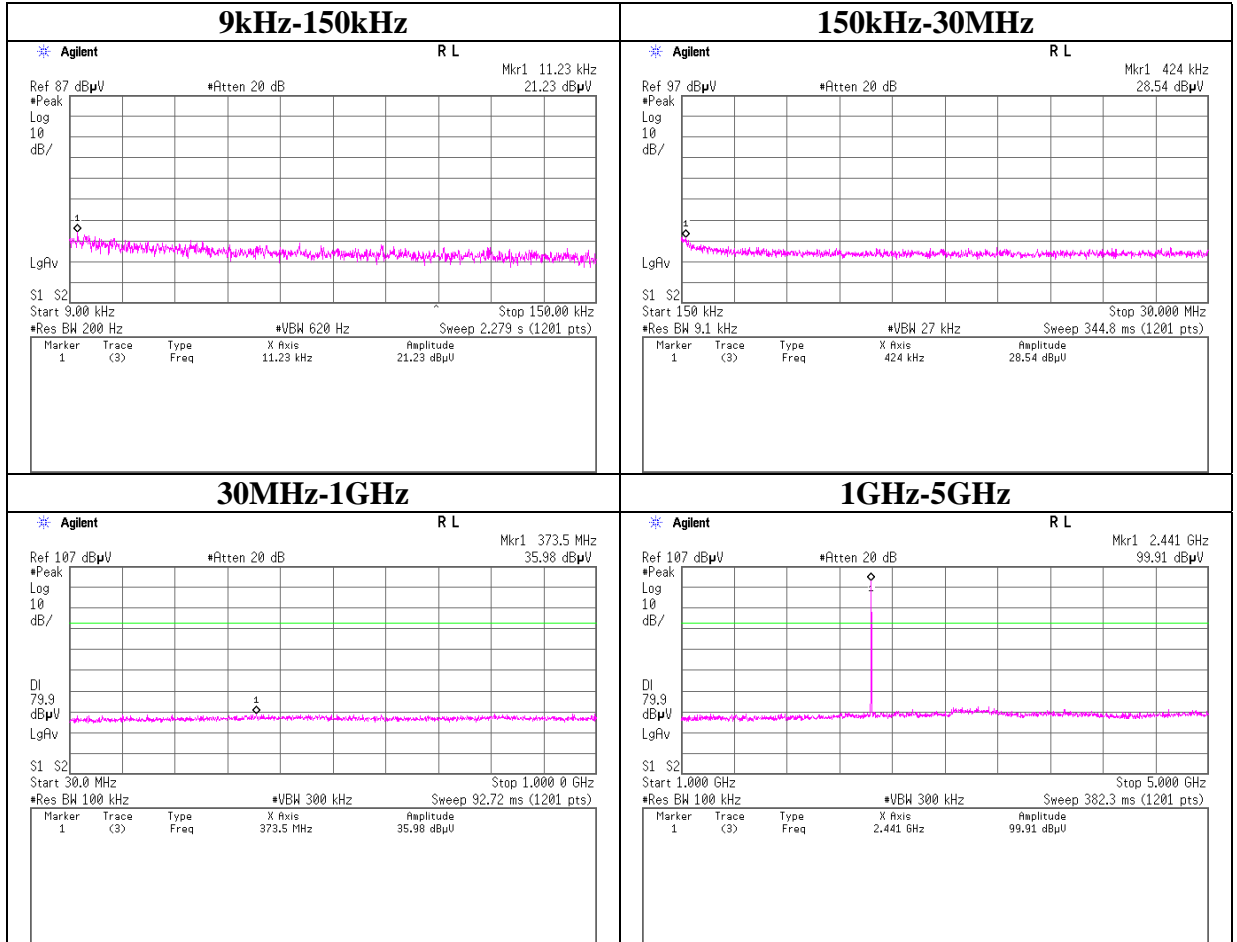

## Conducted Spurious Emission

### Tx DH5 2441MHz

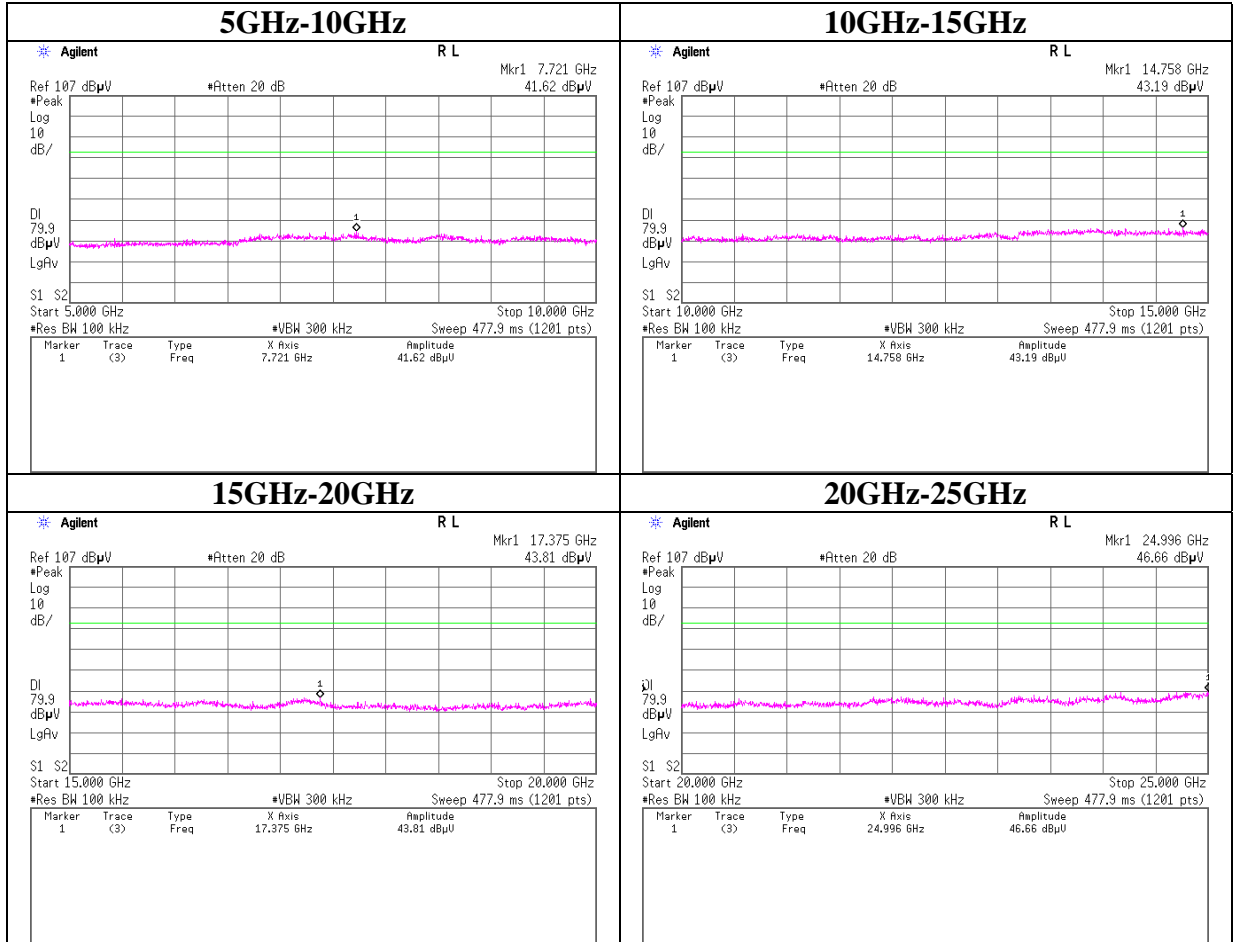

**Conducted Spurious Emission**

**Tx DH5 2480MHz**

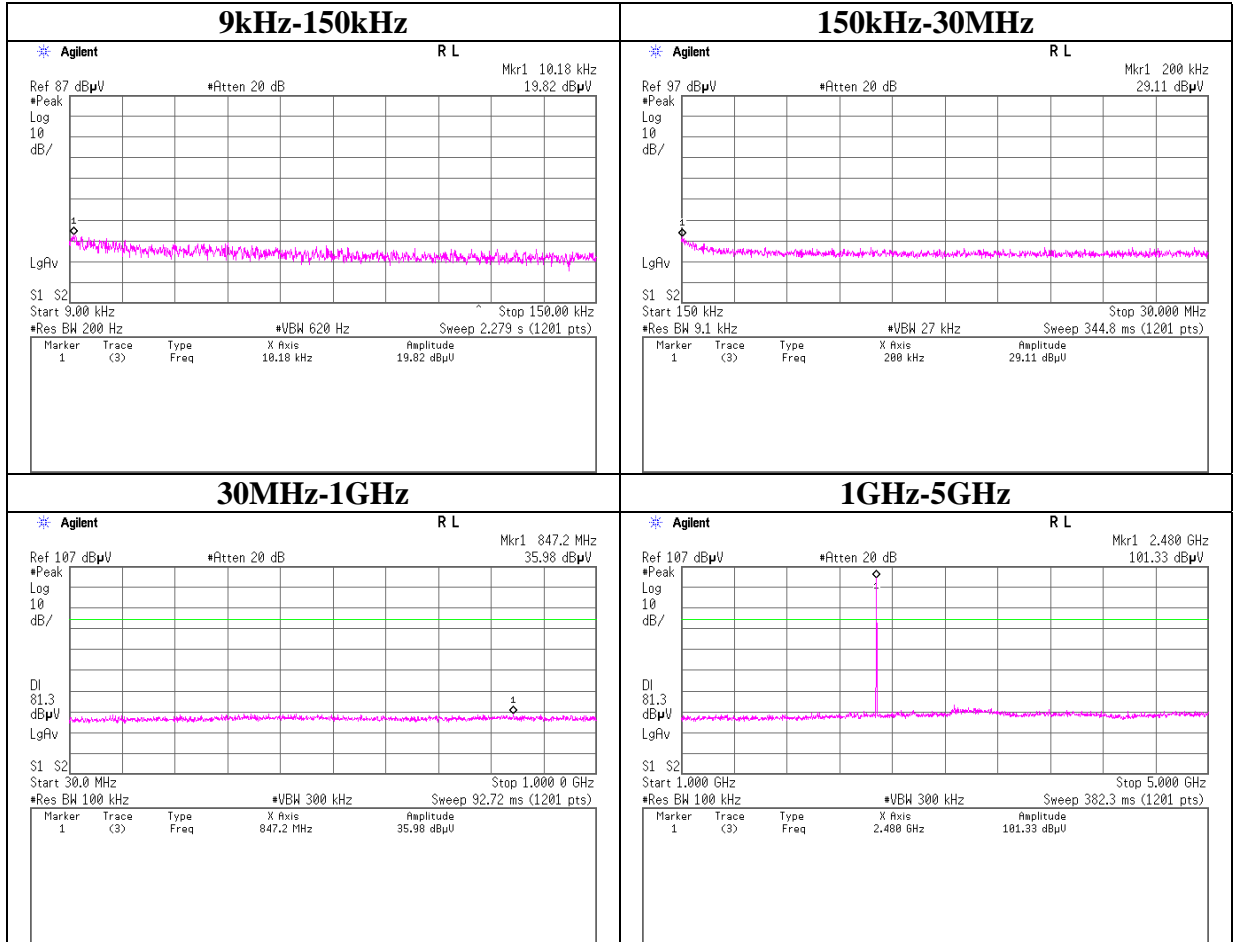

## Conducted Spurious Emission

### Tx DH5 2480MHz

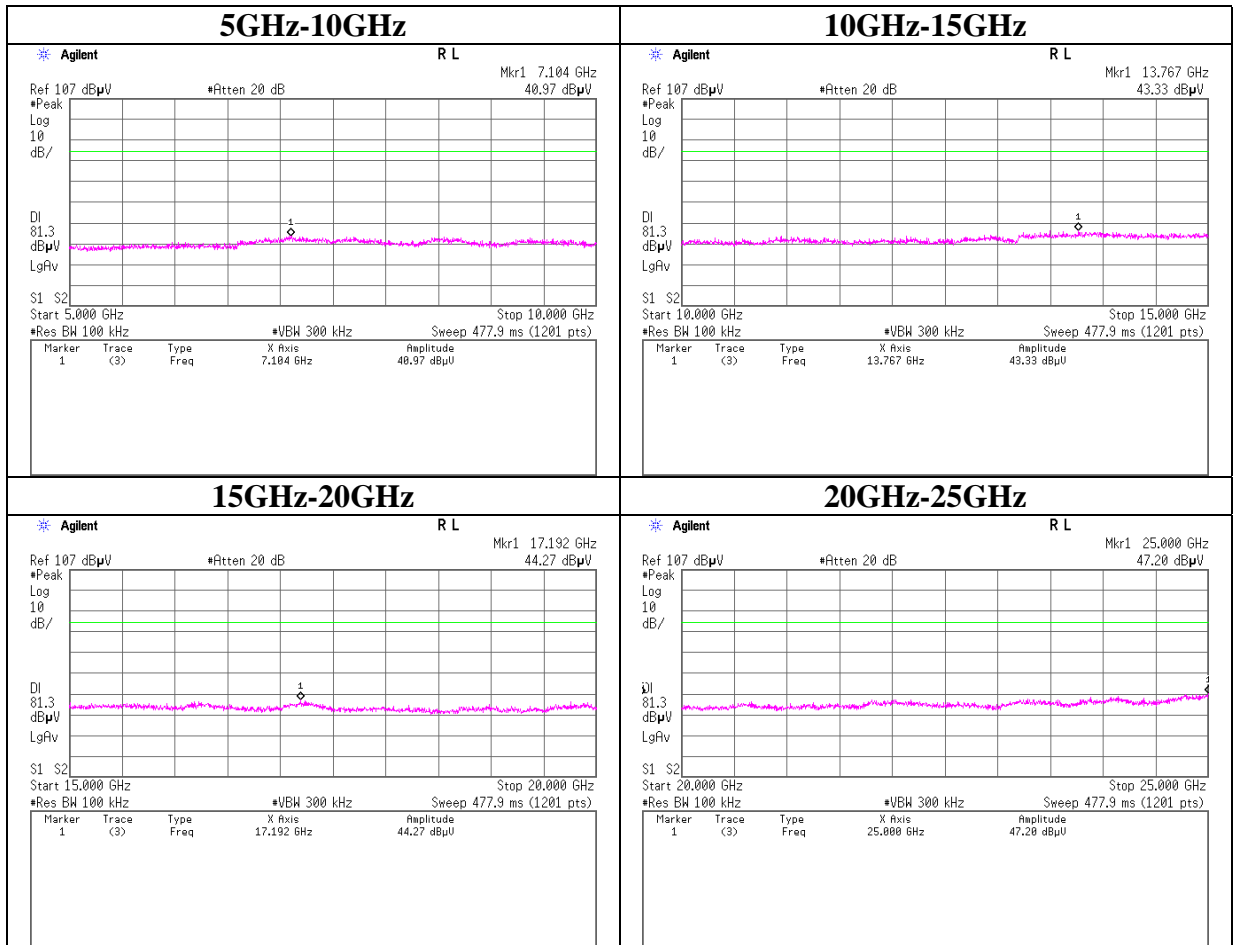

**Conducted Spurious Emission**

**Tx 3DH5 2402MHz**

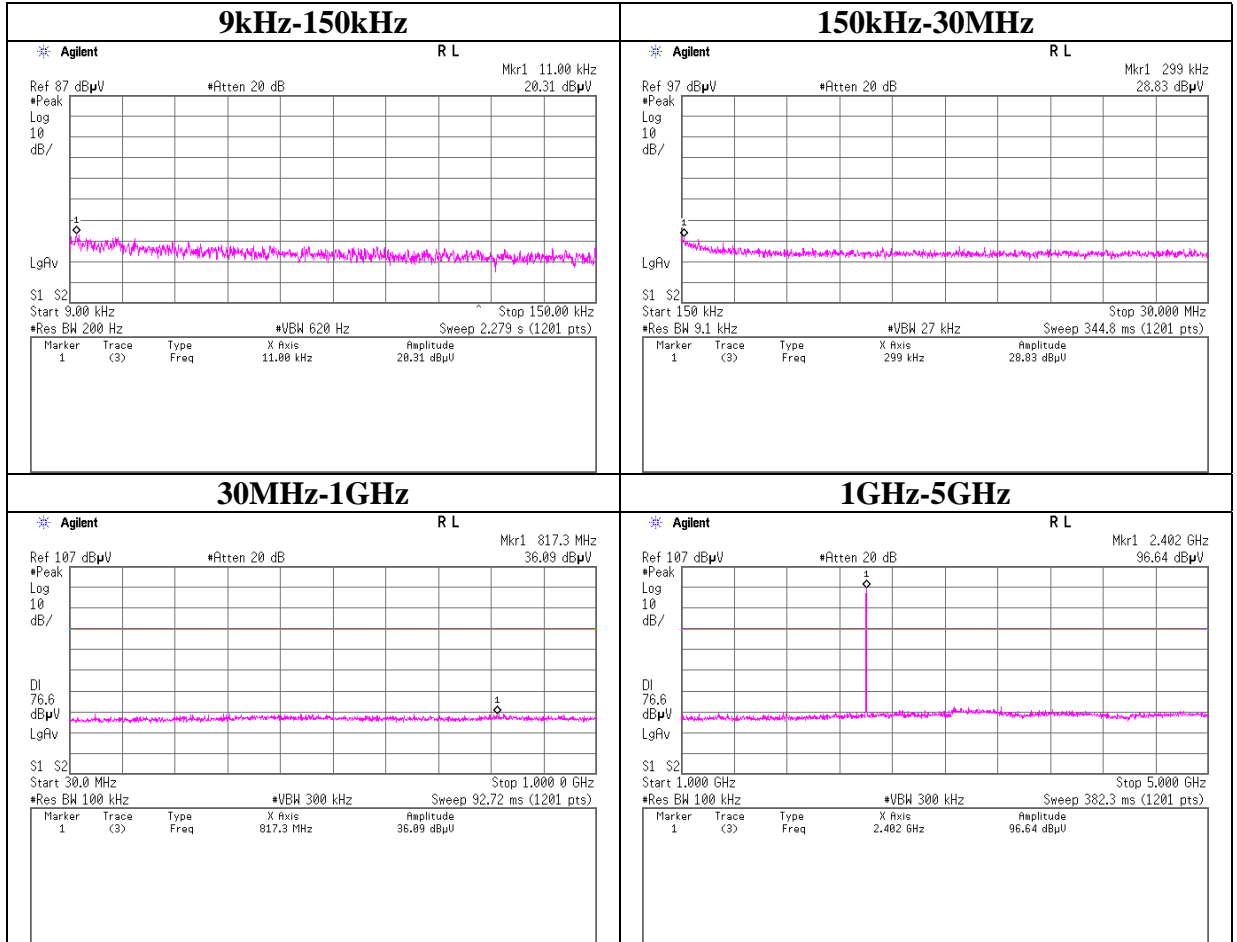

## Conducted Spurious Emission

### Tx 3DH5 2402MHz

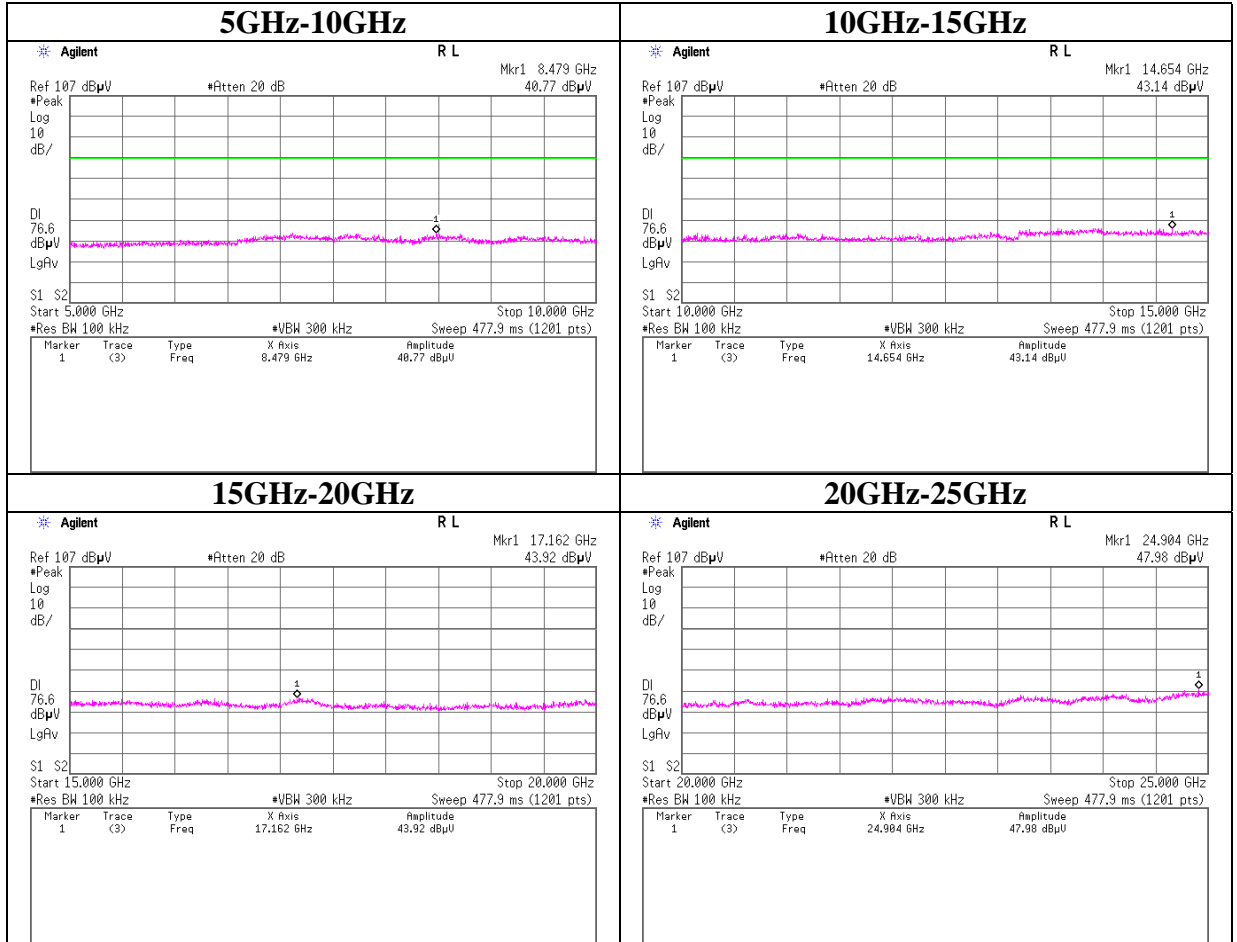

## Conducted Spurious Emission

### Tx 3DH5 2441MHz

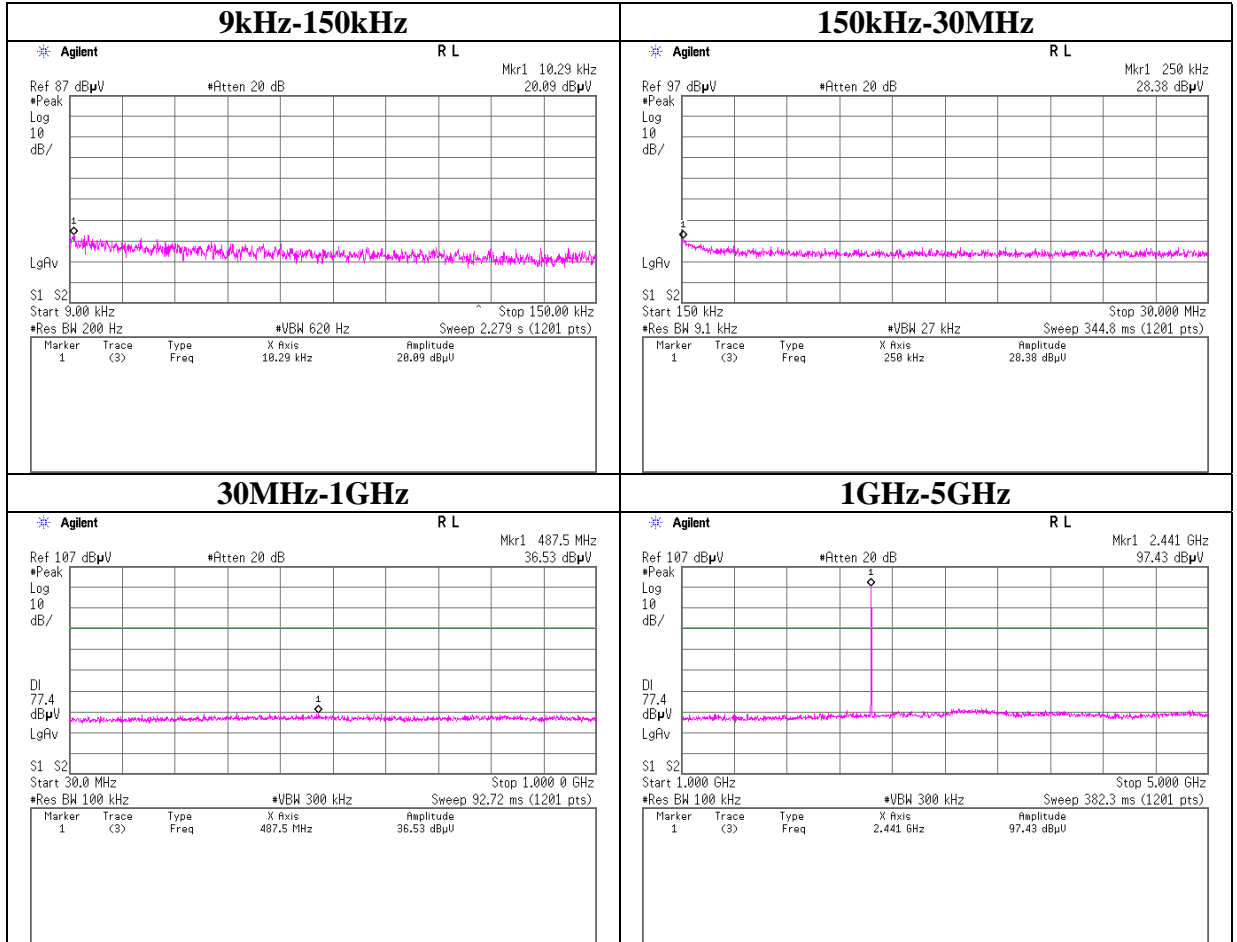

**Conducted Spurious Emission**

**Tx 3DH5 2441MHz**

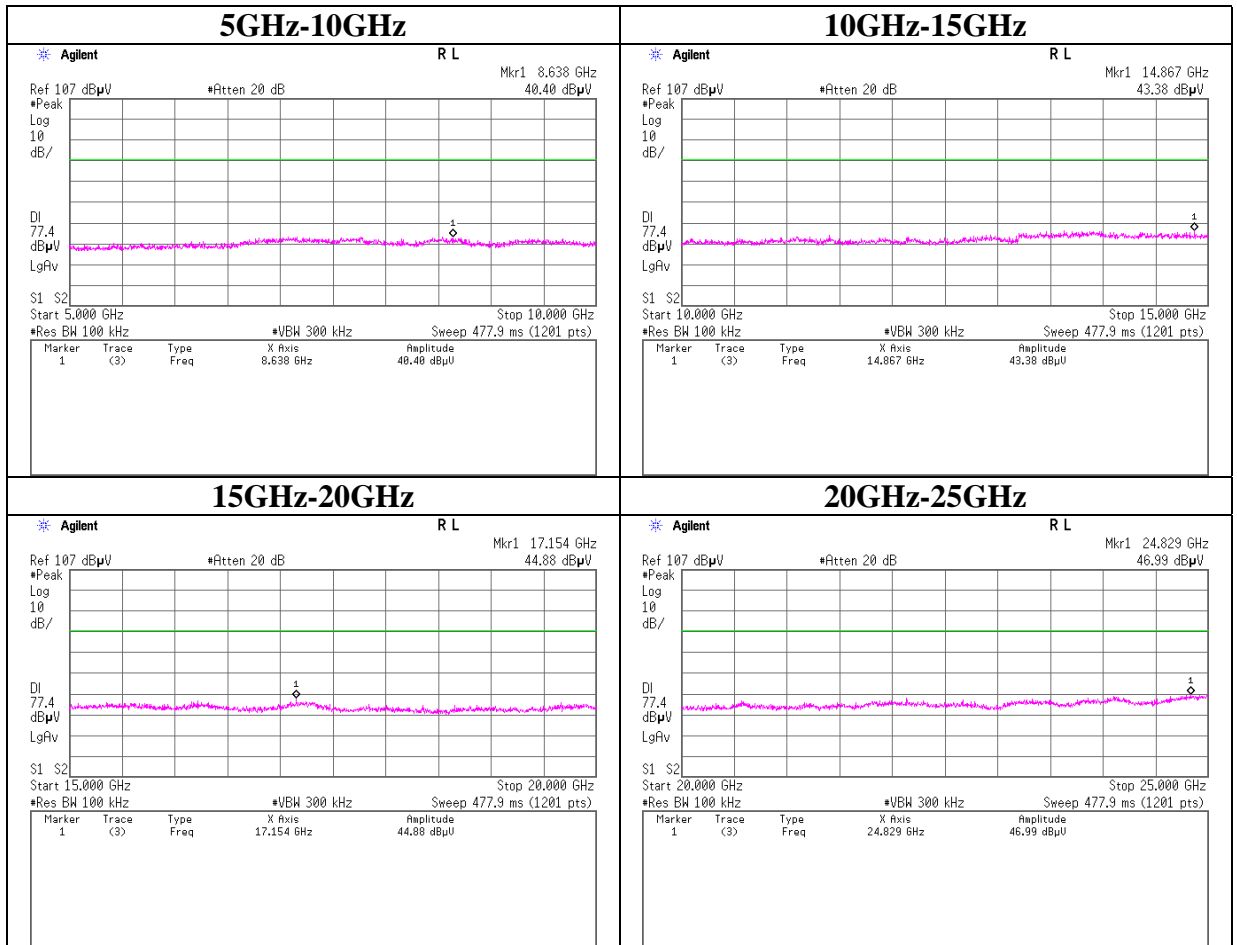

## Conducted Spurious Emission

### Tx 3DH5 2480MHz

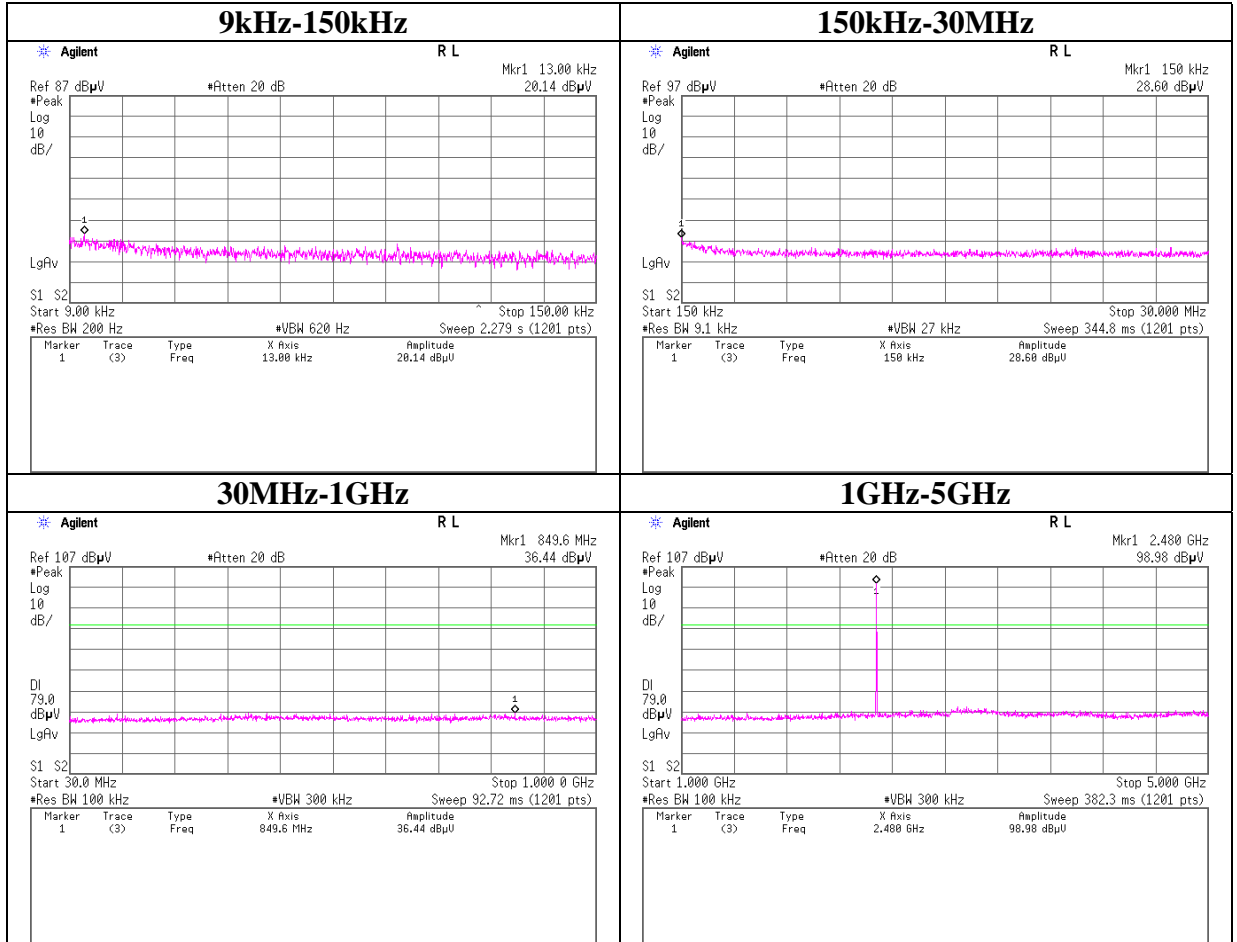

## Conducted Spurious Emission

### Tx 3DH5 2480MHz

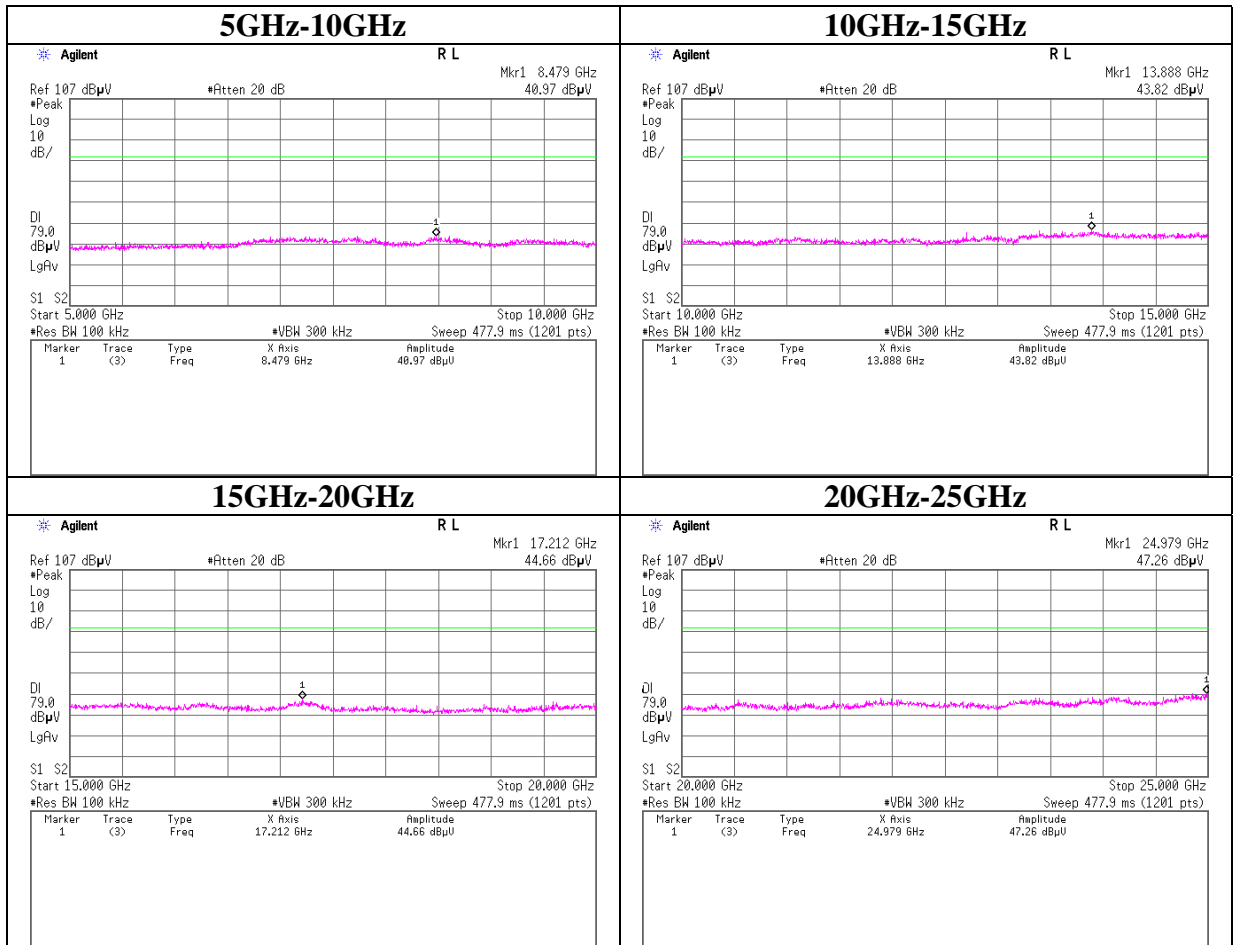

**Conducted Emission Band Edge compliance**

**Tx DH5, Hopping on**

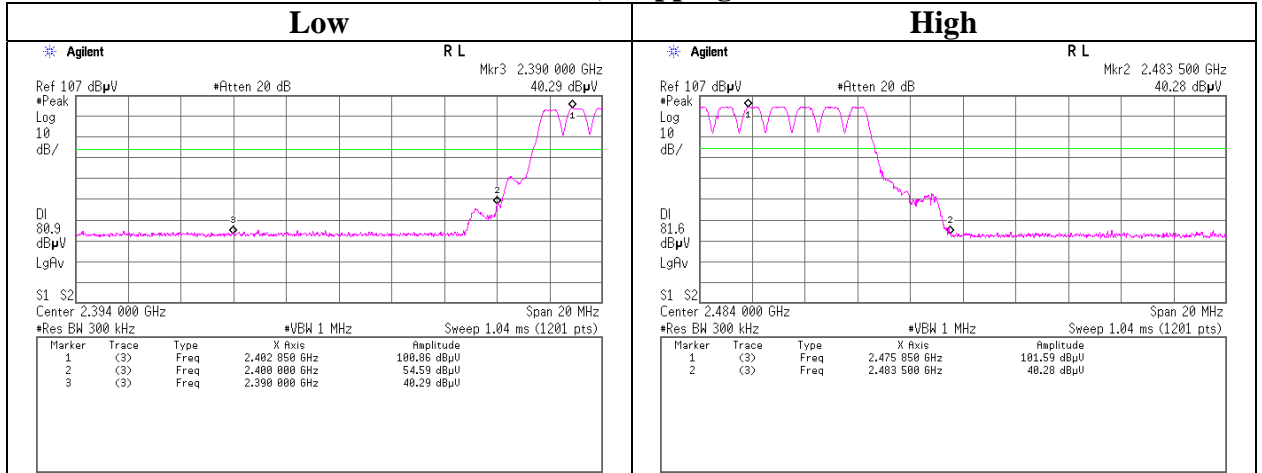

**Tx DH5, Hopping off**

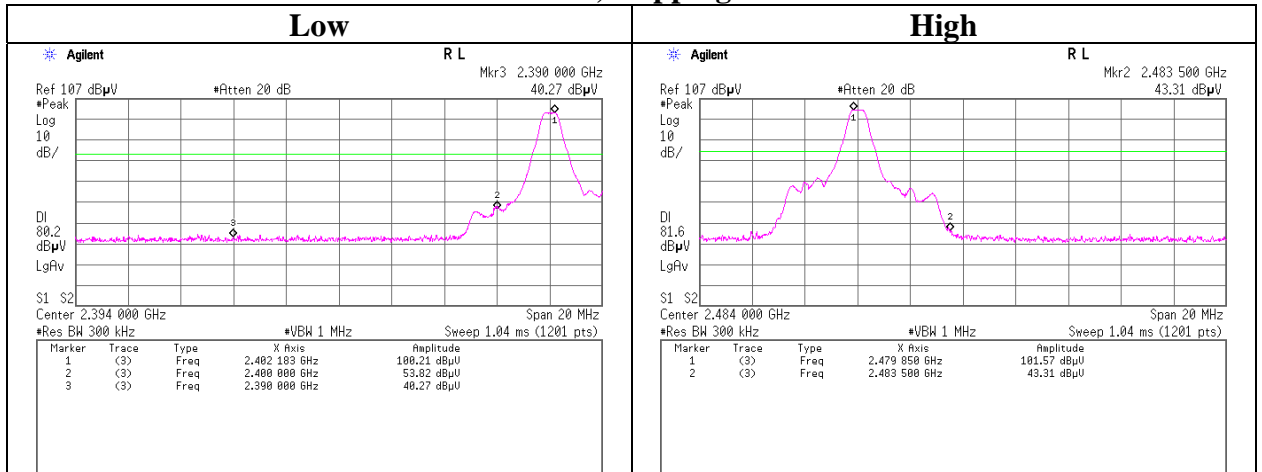

**Conducted Emission Band Edge compliance**

**Tx 3DH5, Hopping on**

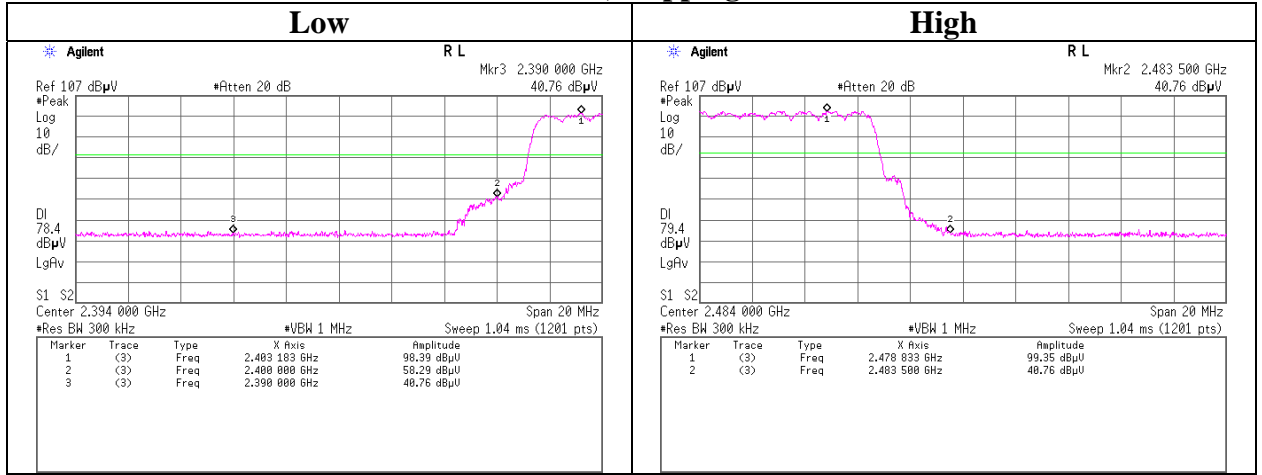

**Tx 3DH5, Hopping off**

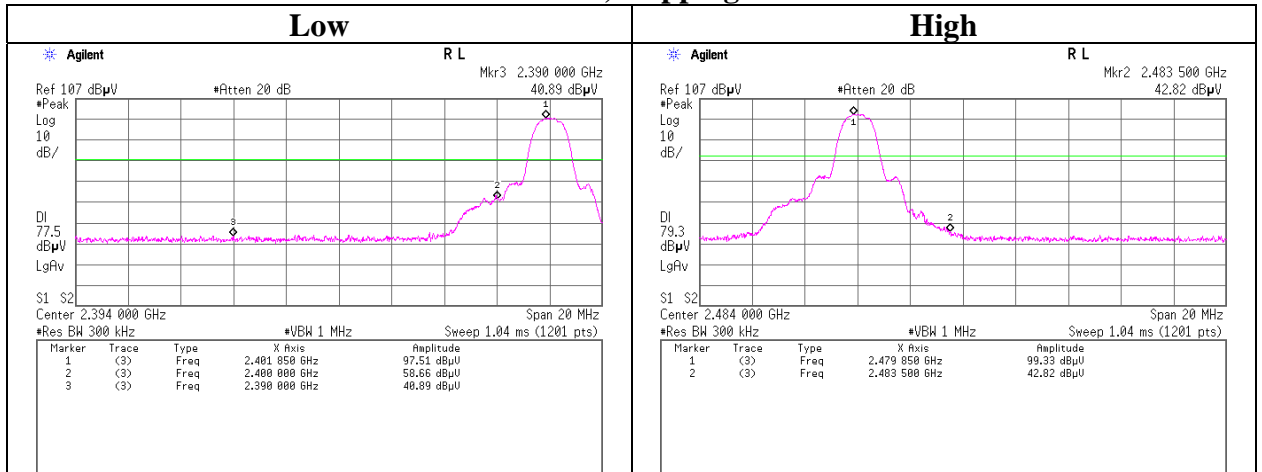

**99% Occupied Bandwidth**

**Tx DH5, Hopping off**

**Tx 3DH5, Hopping off**

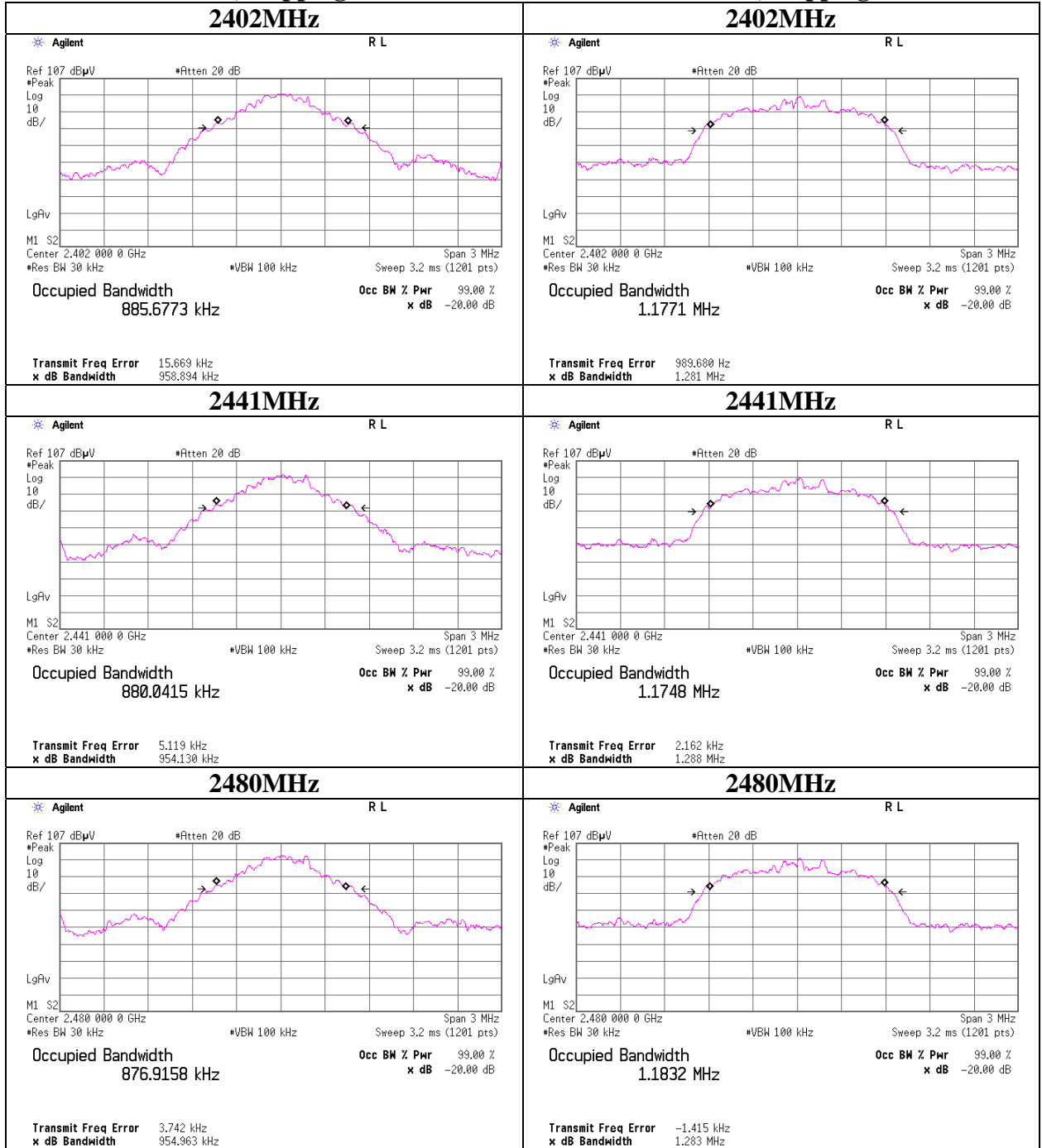

## 99% Occupied Bandwidth

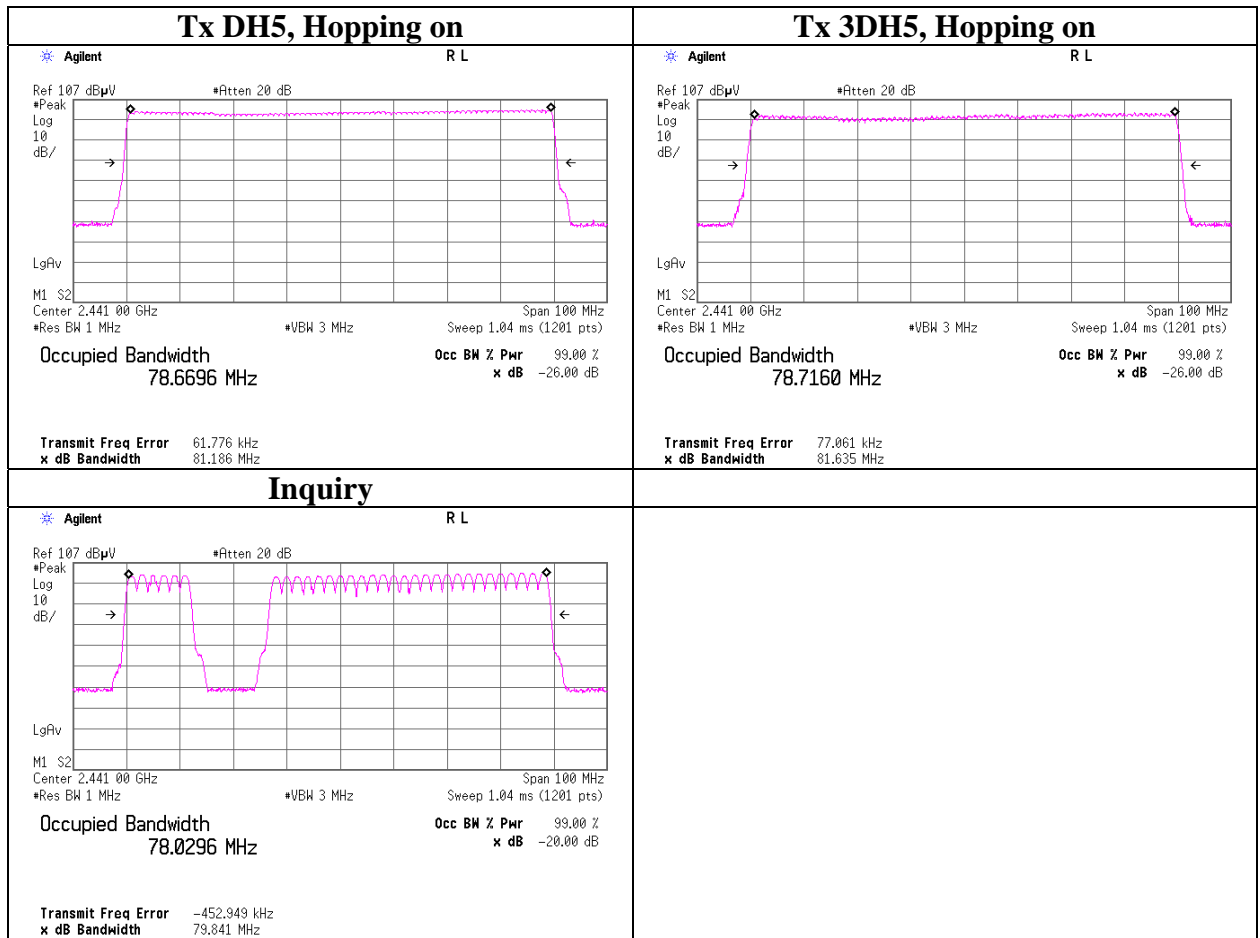

## APPENDIX 2: Test instruments

### EMI test equipment

Control No.	Instrument	Manufacturer	Model No	Serial No	Test Item	Calibration Date * Interval(month)
MAEC-02	Semi Anechoic Chamber(NSA)	TDK	Semi Anechoic Chamber 3m	DA-06902	RE/CE	2011/06/21 * 12
MOS-22	Thermo-Hygrometer	Custom	CTH-201	0003	RE/CE	2011/02/23 * 12
MJM-14	Measure	KOMELON	KMC-36	-	RE/CE	-
COTS-MEMI	EMI measurement program	TSJ	TEPTO-DV	-	RE/CE	-
MSA-03	Spectrum Analyzer	Agilent	E4448A	MY44020357	RE	2010/11/30 * 12
MSA-05	Spectrum Analyzer	Advantest	R3273	160400285	RE/CE	2010/11/18 * 12
MTR-03	Test Receiver	Rohde & Schwarz	ESCI	100300	RE/CE	2011/04/15 * 12
MBA-02	Biconical Antenna	Schwarzbeck	BBA9106	VHA91032008	RE	2011/09/10 * 12
MLA-02	Logperiodic Antenna	Schwarzbeck	USLP9143	201	RE	2011/09/10 * 12
MCC-12	Coaxial Cable	Fujikura/Agilent	-	-	RE	2011/02/18 * 12
MAT-07	Attenuator(6dB)	Weinschel Corp	2	BK7970	RE	2010/11/05 * 12
MPA-09	Pre Amplifier	Agilent	8447D	2944A10845	RE	2011/09/26 * 12
MHA-06	Horn Antenna 1-18GHz	Schwarzbeck	BBHA9120D	254	RE	2011/01/16 * 12
MPA-10	Pre Amplifier	Agilent	8449B	3008A02142	RE	2011/09/21 * 12
MHA-02	Horn Antenna 18-26.5GHz	EMCO	3160-09	1265	RE	2011/01/16 * 12
MCC-77	Microwave Cable 1G-26.5GHz	Suhner	SUCOFLEX104	278942/4	RE	2010/12/02 * 12
MHF-18	High Pass Filter 3.5-18.0GHz	TOKIMEC	TF323DCA	7002	RE	2011/09/08 * 12
MLS-06	LISN(AMN)	Schwarzbeck	NSLK8127	8127363	CE(EUT)	2011/02/20 * 12
MTA-31	Terminator	TME	CT-01	-	CE	2011/01/05 * 12
MCC-13	Coaxial Cable	Fujikura	3D-2W(12m)/5D-2W(5m)/5D-2W(0.8m)/5D-2W(1m)	-	CE	2011/02/18 * 12
MAT-65	Attenuator(13dB)	JFW Industries, Inc.	50FP-013H2 N	-	CE	2011/02/21 * 12
MOS-04	Digital Humidity Indicator	N.T	NT-1800	MOS04	AT	2011/02/23 * 12
MSA-03	Spectrum Analyzer	Agilent	E4448A	MY44020357	AT	2010/11/30 * 12
MPM-08	Power Meter	Anritsu	ML2495A	6K00003338	AT	2011/09/13 * 12
MPSE-11	Power sensor	Anritsu	MA2411B	011737	AT	2011/09/13 * 12
MCC-93	Microwave Cable 1G-40GHz	Schner	SUCOFLEX102	30814/2	AT	2011/05/27 * 12
MAT-25	Attenuator(10dB)(above 1GHz)	Agilent	8493C	71642	AT	2011/06/23 * 12
MPSC-01	Power splitters/Combiners	Mini-Circuit	ZFSC-2-2500	0124	AT	2011/09/27 * 12

The expiration date of the calibration is the end of the expired month.

All equipment is calibrated with valid calibrations. Each measurement data is traceable to the national or international standards.

As for some calibrations performed after the tested dates, those test equipment have been controlled by means of an unbroken chains of calibrations.

Test Item: CE: Conducted Emission  
RE: Radiated Emission  
AT: Antenna Terminal Conducted test

**UL Japan, Inc.**

**Head Office EMC Lab.**

4383-326 Asama-cho, Ise-shi, Mie-ken 516-0021 JAPAN

Telephone : +81 596 24 8116

Facsimile : +81 596 24 8124