



RADIO TEST REPORT

Test Report No.: 32FE0253-HO-P

Applicant : SAMSUNG ELECTRONICS CO., LTD.
Type of Equipment : GPRS850/1900, EDGE850/1900, WCDMA2,
WCDMA5 Tablet with 802.11bgn, BT3.0+EDR
Model No. : GT-P5100
Test standard : FCC Part 24 Subpart E: 2008
(Radiated tests only)
FCC ID : A3LGTP5100
Test Result : **Complied**

1. This test report shall not be reproduced in full or partial, without the written approval of UL Japan, Inc
2. The results in this report apply only to the sample tested.
3. This sample tested is in compliance with the above regulation.
4. The test results in this report are traceable to the national or international standards.
5. This test report must not be used by the customer to claim product certification, approval, or endorsement by NVLAP, NIST, or any agency of the Federal Government.

Date of test: March 1, 2012

Representative test engineer:

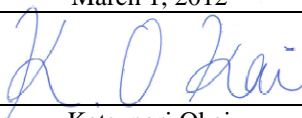
Katsunori Okai
Engineer of WiSE Japan,
UL Verification Service

Approved by:

Takahiro Hatakeda
Leader of WiSE Japan,
UL Verification Service



NVLAP LAB CODE: 200572-0

This laboratory is accredited by the NVLAP LAB CODE 200572-0, U.S.A. The tests reported herein have been performed in accordance with its terms of accreditation.
*As for the range of Accreditation in NVLAP, you may refer to the WEB address,
<http://www.ul.com/japan/jpn/pages/services/emc/about/mark1/index.jsp#nvlap>

UL Japan, Inc.

Head Office EMC Lab.

4383-326 Asama-cho, Ise-shi, Mie-ken 516-0021 JAPAN

Telephone : +81 596 24 8116

Facsimile : +81 596 24 8124

CONTENTS	PAGE
SECTION 1: Customer information	3
SECTION 2: Equipment under test (E.U.T.)	3
SECTION 3: Test specification, procedures & results	5
SECTION 4: Operation of E.U.T. during testing.....	7
SECTION 5: RF Output Power(Radiated).....	9
SECTION 6: Spurious Emission and Band-Edge (Radiated)	10
APPENDIX 1: Data of EMI test	11
RF Output Power (Radiated)	11
Band-Edge (Radiated)	13
Spurious Emission (Radiated)	14
APPENDIX 2: Test instruments	16
APPENDIX 3: Photographs of test setup.....	17
Radiated Spurious Emission.....	17
Worst Case Position (Horizontal: Y-axis/ Vertical:Z-axis)	18

SECTION 1: Customer information

Company Name : SAMSUNG ELECTRONICS CO., LTD.
Address : 416, MAETAN 3-DONG, YEONGTONG-GU SUWON-CITY,
GYEONGGI-DO 443-742, SOUTH KOREA

SECTION 2: Equipment under test (E.U.T.)

2.1 Identification of E.U.T.

Type of Equipment : GPRS850/1900, EDGE850/1900, WCDMA2, WCDMA5 Tablet with
802.11bgn, BT3.0+EDR
Model No. : GT-P5100
Serial No. : Refer to Section 4, Clause 4.2
Rating : DC5.0V
Receipt Date of Sample : February 6, 2012
Modification of EUT : No Modification by the test lab

2.2 Product Description

Radio Specification

Bluetooth

Equipment Type	Transceiver
Frequency of Operation	2402-2480MHz
Type of Modulation	FHSS
Bandwidth & Channel spacing	1MHz & 1MHz
Antenna Type	PIFA
Antenna Gain	-0.31 dBi (MAX)

WLAN (IEEE802.11b/g/n-20)

Equipment Type	Transceiver
Frequency of Operation	2412-2462MHz
Type of Modulation	DSSS, OFDM
Bandwidth & Channel spacing	20MHz & 5MHz
Antenna Type	PIFA
Antenna Gain	-0.31 dBi (MAX)

UL Japan, Inc.

Head Office EMC Lab.

4383-326 Asama-cho, Ise-shi, Mie-ken 516-0021 JAPAN

Telephone : +81 596 24 8116

Facsimile : +81 596 24 8124

GSM

Equipment Type	Transceiver
Frequency of Operation	[Up Link] GSM850: 824 – 849MHz PCS: 1850 – 1910MHz [Down Link] GSM850: 869 – 894MHz PCS: 1930 – 1990MHz
Type of Modulation	GMSK , 8PSK
Emission Designator	GSM850: 249KGXW, 256KG7W PCS: 249KGXW, 262KG7W
Antenna Type	PIFA
Antenna Gain	GSM850: 824-849MHz: -4.41dBi (MAX) 869-894MHz: -3.77dBi (MAX) PCS: 1850-1910MHz: 1.65dBi (MAX) 1930-1990MHz: -1.79dBi (MAX)

W-CDMA

Equipment Type	Transceiver
Frequency of Operation	[Up Link] Band V: 824 – 849MHz Band II: 1850 – 1910MHz [Down Link] Band V: 869 – 894MHz Band II: 1930 – 1990MHz
Type of Modulation	QPSK
Emission Designator	Band V: 4M06F9W Band II: 4M06F9W
Antenna Type	PIFA
Antenna Gain	Band V: 824-849MHz: -4.41dBi (MAX) 869-894MHz: -3.77dBi (MAX) Band II: 1850-1910MHz: 1.65dBi (MAX) 1930-1990MHz: -1.79dBi (MAX)

*This test report includes Radiated test results due to the change of GSM/WCDMA antenna and minor change of the enclosure from the original model (FCC ID: A3LGTP5100).

SECTION 3: Test specification, procedures & results

3.1 Test Specification

Test Specification : FCC Part 24 Subpart E: 2008, final revised on May 2, 2008
Title : FCC 47CFR Part 24 Subpart E
Broadband PCS

3.2 Procedures and results

Item	Test Specification & Procedure	Remarks	Deviation	Worst margin	Results
RF Output Power(Radiated) (Equivalent isotropic radiated power(EIRP))	FCC 2.1046 FCC 24.232(c)	Radiated	N/A	-	Complied
Band-Edge	FCC 2.1051 FCC 2.1053 FCC 24.238	Radiated	N/A	GSM 7.6dB 1849.98MHz, Vertical W-CDMA 4.5dB 1910.00MHz, Horizontal	Complied
Spurious Emission(Radiated)	FCC 2.1053 FCC 24.238	Radiated	N/A	GSM 36.9dB 3700.40MHz, Horizontal W-CDMA 31.4dB 3760.00MHz, Horizontal	Complied

Note: UL Japan's EMI Work Procedures No. 13-EM-W0420

*These tests were also referred to ANSI/TIA 603-C-2004 "Land Mobile FM or PM Communications Equipment Measurement and Performance Standards."

*These tests were performed without any deviations from test procedure except for additions or exclusions.

3.3 Uncertainty

EMI

The following uncertainties have been calculated to provide a confidence level of 95% using a coverage factor k=2.

Radiated Emission (EUT height: 0.8m) (\pmdB)	
Measurement Distance 3m	
30MHz-300MHz	5.4dB
300MHz-1000MHz	4.0dB
1GHz-12.75GHz	4.4dB

Radiated emission test(3m)

The data listed in this test report has enough margin, more than the site margin.

UL Japan, Inc.

Head Office EMC Lab.

4383-326 Asama-cho, Ise-shi, Mie-ken 516-0021 JAPAN

Telephone : +81 596 24 8116

Facsimile : +81 596 24 8124

3.4 Test Location

UL Japan, Inc. Head Office EMC Lab. *NVLAP Lab. code: 200572-0
4383-326 Asama-cho, Ise-shi, Mie-ken 516-0021 JAPAN
Telephone : +81 596 24 8116 Facsimile : +81 596 24 8124

	FCC Registration Number	IC Registration Number	Width x Depth x Height (m)	Size of reference ground plane (m) / horizontal conducting plane	Other rooms
No.1 semi-anechoic chamber	313583	2973C-1	19.2 x 11.2 x 7.7m	7.0 x 6.0m	No.1 Power source room
No.2 semi-anechoic chamber	655103	2973C-2	7.5 x 5.8 x 5.2m	4.0 x 4.0m	-
No.3 semi-anechoic chamber	148738	2973C-3	12.0 x 8.5 x 5.9m	6.8 x 5.75m	No.3 Preparation room
No.3 shielded room	-	-	4.0 x 6.0 x 2.7m	N/A	-
No.4 semi-anechoic chamber	134570	2973C-4	12.0 x 8.5 x 5.9m	6.8 x 5.75m	No.4 Preparation room
No.4 shielded room	-	-	4.0 x 6.0 x 2.7m	N/A	-
No.5 semi-anechoic chamber	-	-	6.0 x 6.0 x 3.9m	6.0 x 6.0m	-
No.6 shielded room	-	-	4.0 x 4.5 x 2.7m	4.75 x 5.4 m	-
No.6 measurement room	-	-	4.75 x 5.4 x 3.0m	4.75 x 4.15 m	-
No.7 shielded room	-	-	4.7 x 7.5 x 2.7m	4.7 x 7.5m	-
No.8 measurement room	-	-	3.1 x 5.0 x 2.7m	N/A	-
No.9 measurement room	-	-	8.0 x 4.5 x 2.8m	2.0 x 2.0m	-
No.10 measurement room	-	-	2.6 x 2.8 x 2.5m	2.4 x 2.4m	-
No.11 measurement room	-	-	3.1 x 3.4 x 3.0m	2.4 x 3.4m	-

* Size of vertical conducting plane (for Conducted Emission test) : 2.0 x 2.0m for No.1, No.2, No.3, and No.4 semi-anechoic chambers and No.3 and No.4 shielded rooms.

3.5 Test set up, Test instruments and Data of EMI

Refer to APPENDIX.

SECTION 4: Operation of E.U.T. during testing

4.1 Operating Modes

<PCS1900>

Test	Operating mode	Power Control	Tested frequency	Channel
RF output Power(Radiated)	Transmitting (Tx) (GSM, GMSK, 1slot) Transmitting (Tx) (EGPRS, 8PSK, 2slot, MCS-5)	Max (PCL=0)	1850.2MHz 1880.0MHz 1909.8MHz	512 661 810
Band Edge(Radiated)	Transmitting (Tx) (GSM, GMSK, 1slot)	Max (PCL=0)	1850.2MHz 1909.8MHz	512 810
Spurious Emission(Radiated)	Transmitting (Tx) (GSM, GMSK, 1slot)	Max (PCL=0)	1850.2MHz 1880.0MHz 1909.8MHz	512 661 810

[GSM, GPRS]

*Single slot (1 slot) which had the highest frame power was tested as a representative.

[EGPRS]

*Multi slot (2 slot) which had the highest frame power was tested as a representative.

<W-CDMA Band II>

Test	Operating mode	Power Control	Tested frequency	Channel
RF output Power (Radiated), Spurious Emission (Radiated)	Transmitting (Tx) W-CDMA (RMC12.2kbps)	TPC All Up bits(Max)	1852.4 MHz 1880.0 MHz 1907.6 MHz	9262 9400 9538
Band Edge (Radiated)	Transmitting (Tx) W-CDMA (RMC12.2kbps)	TPC All Up bits(Max)	1852.4 MHz 1907.6 MHz	9262 9538

UL Japan, Inc.

Head Office EMC Lab.

4383-326 Asama-cho, Ise-shi, Mie-ken 516-0021 JAPAN

Telephone : +81 596 24 8116

Facsimile : +81 596 24 8124

4.2 Configuration and peripherals

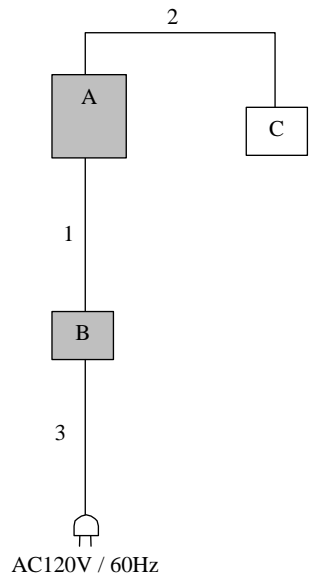

* Cabling and setup(s) were taken into consideration and test data was taken under worse case conditions.

Description of EUT and Support equipment

No.	Item	Model number	Serial number	Manufacturer	Remarks
A	GPRS850/1900, EDGE850/1900, WCDMA2, WCDMA5 Tablet with 802.11bgn, BT3.0+EDR	GT-P5100	R31C10LL01K	SAMSUNG	EUT
B	AC Adapter	ETA-P11X	-	SAMSUNG	EUT
C	Ear phone	-	-	SAMSUNG	-

List of cables used

No.	Name	Length (m)	Shield		Remarks
			Cable	Connector	
1	USB Cable	1.0	Shielded	Shielded	-
2	Ear phone Cable	1.2	Unshielded	Unshielded	-
3	AC Cable	0.9	Unshielded	Unshielded	-

UL Japan, Inc.

Head Office EMC Lab.

4383-326 Asama-cho, Ise-shi, Mie-ken 516-0021 JAPAN

Telephone : +81 596 24 8116

Facsimile : +81 596 24 8124

SECTION 5: RF Output Power(Radiated)

[Radiated : Equivalent isotropic radiated power(EIRP)]

Test Procedure

- 1) EUT was placed on a platform of nominal size, 0.5 by 1.0m, raised 80cm above the conducting ground plane. Test was made with the antenna positioned in both the horizontal and vertical planes of polarization. The Radiated Electric Field Strength intensity has been measured in a semi anechoic chamber with a ground plane and at a distance of 3m.
The measuring antenna height varied between 1 and 4m and EUT was rotated a full revolution in order to obtain the maximum value of the electric field intensity.

- 2) Exchanged the EUT to the Substitution Antenna, the measurement was set for the same height as the EUT. The frequency above 1GHz of the Substitution antenna was used with Horn antenna calibrated with the Half wave dipole antenna, which is harmonized with the measured frequency in 1).
The Substitution Antenna was connected with the Signal Generator, and the polarized electromagnetic radiation of the Substitution Antenna was matched with the one of the measuring Antenna, which was set with the Signal Generator to the measured frequency in 1). Then, we set with the Output power (CW) of the Signal Generator where the measuring electromagnetic field is equal to the measured value in 1).
The measuring antenna height varied between 1 and 4m to obtain the maximum receiving level.
Its Output power of Signal Generator was recorded.

- 3) Equivalent isotropic radiated power(EIRP) was calculated by subtracting the cable loss and the attenuator loss connected between the Signal Generator and the Substitution Antenna from the Output power of the Signal Generator recorded in 2).

- The carrier level and noise levels were confirmed at each position of X, Y and Z axis of EUT to see the position of maximum noise, and the test was made at the position that has the maximum noise.

Test data : **APPENDIX 1**
Test result : **Pass**

SECTION 6: Spurious Emission and Band-Edge (Radiated)

[Radiated]

Test Procedure

- 1) EUT was placed on a platform of nominal size, 0.5m by 1.0m, raised 80cm above the conducting ground plane. Test was made with the antenna positioned in both the horizontal and vertical planes of polarization. The Radiated Electric Field Strength intensity has been measured in a semi anechoic chamber with a ground plane and at a distance of 3m.
The measuring antenna height was varied between 1 to 4m and EUT was rotated a full revolution in order to obtain the maximum value of the electric field intensity.
- 2) Exchanged the EUT to the Substitution Antenna, the antenna was set for the same height as EUT on the table.
The frequency below 1GHz of the Substitution antenna was used as the Half wave dipole antenna and Shorted dipole antenna calibrated with the Half wave dipole antenna, which is harmonized with the measured frequency in 1). The frequency above 1GHz of the Substitution antenna was used with Horn antenna calibrated with the Half wave dipole antenna.
The Substitution antenna was connected with the Signal Generator, and the polarized electromagnetic radiation of the Substitution antenna was matched with the one of the measuring antenna, which was set with the Signal Generator to the measured frequency in 1). Then, we set with the Output power (CW) of the Signal Generator where the measuring electromagnetic field is equal to the measured value in 1).
The measuring antenna height varied between 1 and 4m to obtain the maximum receiving level.
Its Output power of Signal Generator was recorded.
- 3) Equivalent isotropic radiated power was calculated by subtracting the cable loss and the attenuator loss connected between the Signal Generator and the Substitution Antenna from the Output power of the Signal Generator recorded in 2).

- The carrier level and noise levels were confirmed at each position of X, Y and Z axis of EUT to see the position of maximum noise, and the test was made at the position that has the maximum noise.

Test data : **APPENDIX 1**
Test result : **Pass**

APPENDIX 1: Data of EMI test

RF Output Power (Radiated)
Equivalent Isotropically Radiated Power(EIRP)
PCS1900

Report No. 32FE0253-HO
Test place Head Office EMC Lab. No.3 Semi Anechoic Chamber
Date 03/01/2012
Temperature / Humidity 23deg. C / 32% RH
Engineer Katsunori Okai
Mode Tx GSM(GMSK), 1slot, PCL=0

Frequency [MHz]	Rx SA/TR Reading [dBuV]		Tx SG Reading [dBm]		Tx Cable Loss [dB]	Tx Ant. Gain [dBi]	Tx Ant. Atten. Loss [dB]	Result (EIRP) [dBm]		Limit (EIRP) [dBm]	Margin [dB]		Horizontal		Vertical		Remarks		
	HOR	VER	HOR	VER				HOR	VER		HOR	VER	HOR	VER	Rx Ant. Height [cm]	Turn Table [deg.]		Rx Ant. Height [cm]	Turn Table [deg.]
1880.00	97.5	99.0	21.4	22.2	4.0	9.8	0.0	27.1	28.0	33.0	5.9	5.0	100	310	100	280			
1909.80	97.4	98.1	21.3	21.3	4.0	9.8	0.0	27.1	27.1	33.0	5.9	5.9	122	308	100	276			

Calculation Result = SG Reading - Tx Cable Loss + Tx Antenna Gain - Tx Antenna Attenuator Loss
Rx-ANTENNA : Biconical Antenna(30M-300MHz), Logperiodic Antenna(300M-1000MHz), Horn Antenna(1G-40GHz)
Tx-ANTENNA : 120MHz tuned Dipole Antenna(30M-120MHz), Dipole Antenna(120M-1000MHz), Horn Antenna(1G-40GHz)
Other frequency noises omitted in this report were not seen or had enough margin (more than 20dB).
Detector : S/A PK(RBW:3MHz/VBW:8MHz)

Report No. 32FE0253-HO
Test place Head Office EMC Lab. No.3 Semi Anechoic Chamber
Date 03/01/2012
Temperature / Humidity 23deg. C / 32% RH
Engineer Katsunori Okai
Mode Tx EGPRS(8PSK), 2slot, MCS-5, PCL=0

Frequency [MHz]	Rx SA/TR Reading [dBuV]		Tx SG Reading [dBm]		Tx Cable Loss [dB]	Tx Ant. Gain [dBi]	Tx Ant. Atten. Loss [dB]	Result (EIRP) [dBm]		Limit (EIRP) [dBm]	Margin [dB]		Horizontal		Vertical		Remarks		
	HOR	VER	HOR	VER				HOR	VER		HOR	VER	HOR	VER	Rx Ant. Height [cm]	Turn Table [deg.]		Rx Ant. Height [cm]	Turn Table [deg.]
1880.00	97.4	98.9	21.3	22.1	4.0	9.8	0.0	27.0	27.9	33.0	6.0	5.1	100	310	100	276			
1909.80	97.4	98.0	21.3	21.2	4.0	9.8	0.0	27.1	27.0	33.0	5.9	6.0	119	304	100	277			

Calculation Result = SG Reading - Tx Cable Loss + Tx Antenna Gain - Tx Antenna Attenuator Loss
Rx-ANTENNA : Biconical Antenna(30M-300MHz), Logperiodic Antenna(300M-1000MHz), Horn Antenna(1G-40GHz)
Tx-ANTENNA : 120MHz tuned Dipole Antenna(30M-120MHz), Dipole Antenna(120M-1000MHz), Horn Antenna(1G-40GHz)
Other frequency noises omitted in this report were not seen or had enough margin (more than 20dB).
Detector : S/A PK(RBW:3MHz/VBW:8MHz)

RF Output Power (Radiated)
Equivalent Isotropically Radiated Power(EIRP)
W-CDMA Band II

Report No. 32FE0253-HO
Test place Head Office EMC Lab. No.3 Semi Anechoic Chamber
Date 03/01/2012
Temperature / Humidity 23deg. C / 32% RH
Engineer Katsunori Okai
Mode Tx W-CDMA (RMC12.2kbps), All Up Bits

Frequency [MHz]	Rx SA/TR Reading [dBuV]		Tx SG Reading [dBm]		Tx Cable Loss [dB]	Tx Ant. Gain [dBi]	Tx Ant. Atten. Loss [dB]	Result (EIRP) [dBm]		Limit (EIRP) [dBm]	Margin [dB]		Horizontal		Vertical		Remarks
	HOR	VER	HOR	VER				HOR	VER		HOR	VER	Rx Ant. Height [cm]	Turn Table [deg.]	Rx Ant. Height [cm]	Turn Table [deg.]	
	1852.40	94.4	95.4	17.8				17.8	4.0		9.8	0.0	23.6	23.6	33.0	9.4	
1880.00	93.5	94.4	17.2	17.5	4.0	9.8	0.0	23.0	23.2	33.0	10.0	9.8	100	240	100	271	
1907.60	93.8	94.6	17.6	17.7	4.0	9.8	0.0	23.4	23.5	33.0	9.6	9.5	106	184	100	243	

Calculation Result = SG Reading - Tx Cable Loss + Tx Antenna Gain - Tx Antenna Attenuator Loss

Rx-ANTENNA : Biconical Antenna(30M-300MHz), Logperiodic Antenna(300M-1000MHz), Horn Antenna(1G-20GHz)

Tx-ANTENNA : 120MHz tuned Dipole Antenna(30M-120MHz), Dipole Antenna(120M-1000MHz), Horn Antenna(1G-20GHz)

Detector : S/A PK (RBW: 5MHz , VBW: 50MHz)

Band-Edge (Radiated)
PCS1900

Report No. 32FE0253-HO
Test place Head Office EMC Lab. No.3 Semi Anechoic Chamber
Date 03/01/2012
Temperature / Humidity 23deg. C / 32% RH
Engineer Katsunori Okai
Mode Tx GSM(GMSK), 1slot, PCL=0

Frequency [MHz]	Rx SA/TR Reading [dBuV]		Tx SG Reading [dBm]		Tx Cable Loss [dB]	Tx Ant. Gain [dBi]	Tx Ant. Atten. Loss [dB]	Result (EIRP) [dBm]		Limit (EIRP) [dBm]	Margin [dB]		Horizontal		Vertical		Remarks		
	HOR	VER	HOR	VER				HOR	VER		HOR	VER	HOR	VER	Rx Ant.	Turn		Rx Ant.	Turn
															Height [cm]	Table [deg.]		Height [cm]	Table [deg.]
1849.98	49.6	51.0	-26.6	-26.4	4.0	9.8	0.0	-20.8	-20.6	-13.0	7.8	7.6	100	310	100	285			
1850.00	44.5	44.3	-31.7	-33.1	4.0	9.8	0.0	-25.9	-27.3	-13.0	12.9	14.3	100	310	100	285			
1910.00	45.0	44.7	-31.0	-32.0	4.0	9.8	0.0	-25.2	-26.2	-13.0	12.2	13.2	122	308	100	276			
1910.02	48.3	49.3	-27.7	-27.4	4.0	9.8	0.0	-21.9	-21.6	-13.0	8.9	8.6	122	308	100	276			

Calculation Result = SG Reading - Tx Cable Loss + Tx Antenna Gain - Tx Antenna Attenuator Loss
Rx-ANTENNA : Biconical Antenna(30M-300MHz), Logperiodic Antenna(300M-1000MHz), Horn Antenna(1G-40GHz)
Tx-ANTENNA : 120MHz tuned Dipole Antenna(30M-120MHz), Dipole Antenna(120M-1000MHz), Horn Antenna(1G-40GHz)
Other frequency noises omitted in this report were not seen or had enough margin (more than 20dB).
Detector : Tx : S/A AV(RBW:3.6kHz/VBW:10kHz)

Band-Edge (Radiated)
W-CDMA Band II

Report No. 32FE0253-HO
Test place Head Office EMC Lab. No.3 Semi Anechoic Chamber
Date 03/01/2012
Temperature / Humidity 23deg. C / 32% RH
Engineer Katsunori Okai
Mode Tx W-CDMA (RMC12.2kbps), All Up Bits

Frequency [MHz]	Rx SA/TR Reading [dBuV]		Tx SG Reading [dBm]		Tx Cable Loss [dB]	Tx Ant. Gain [dBi]	Tx Ant. Atten. Loss [dB]	Result (EIRP) [dBm]		Limit (EIRP) [dBm]	Margin [dB]		Horizontal		Vertical		Remarks		
	HOR	VER	HOR	VER				HOR	VER		HOR	VER	HOR	VER	Rx Ant.	Turn		Rx Ant.	Turn
															Height [cm]	Table [deg.]		Height [cm]	Table [deg.]
1850.00	51.1	51.6	-25.1	-25.8	4.0	9.8	0.0	-19.4	-20.0	-13.0	6.4	7.0	100	309	100	246			
1910.00	52.7	52.9	-23.3	-23.8	4.0	9.8	0.0	-17.5	-18.0	-13.0	4.5	5.0	123	306	100	254			

Calculation Result = SG Reading - Tx Cable Loss + Tx Antenna Gain - Tx Antenna Attenuator Loss
Rx-ANTENNA : Biconical Antenna(30M-300MHz), Logperiodic Antenna(300M-1000MHz), Horn Antenna(1G-20GHz)
Tx-ANTENNA : 120MHz tuned Dipole Antenna(30M-120MHz), Dipole Antenna(120M-1000MHz), Horn Antenna(1G-20GHz)
Other frequency noises omitted in this report were not seen or had enough margin (more than 20dB).
Detector : S/A PK (RBW: 47kHz, VBW: 150kHz)

Spurious Emission (Radiated)
PCS1900

Report No. 32FE0253-HO
Test place Head Office EMC Lab. No.3 Semi Anechoic Chamber
Date 03/01/2012
Temperature / Humidity 23deg. C / 32% RH
Engineer Katsunori Okai
Mode Tx GSM(GMSK), 1slot, PCL=0

Tx 1850.2MHz

Frequency [MHz]	Rx SA/TR Reading [dBuV]		Tx SG Reading [dBm]		Tx Cable Loss [dB]	Tx Ant. Gain [dBi]	Tx Ant. Atten. Loss [dB]	Result (EIRP) [dBm]		Limit (EIRP) [dBm]	Margin [dB]		Horizontal		Vertical		Remarks		
	HOR	VER	HOR	VER				HOR	VER		HOR	VER	HOR	VER	Rx Ant.	Turn		Rx Ant.	Turn
															Height [cm]	Table [deg.]		Height [cm]	Table [deg.]
3700.40	44.7	44.2	-57.1	-58.2	4.7	11.9	0.0	-49.9	-51.0	-13.0	36.9	38.0	100	300	100	228			

Calculation Result = SG Reading - Tx Cable Loss + Tx Antenna Gain - Tx Antenna Attenuator Loss

Rx-ANTENNA : Biconical Antenna(30M-300MHz), Logperiodic Antenna(300M-1000MHz), Horn Antenna(1G-40GHz)

Tx-ANTENNA : 120MHz tuned Dipole Antenna(30M-120MHz), Dipole Antenna(120M-1000MHz), Horn Antenna(1G-40GHz)

Other frequency noises omitted in this report were not seen or had enough margin (more than 20dB).

Detector : S/A PK(RBW:1MHz/VBW:3MHz)

Tx 1880MHz

Frequency [MHz]	Rx SA/TR Reading [dBuV]		Tx SG Reading [dBm]		Tx Cable Loss [dB]	Tx Ant. Gain [dBi]	Tx Ant. Atten. Loss [dB]	Result (EIRP) [dBm]		Limit (EIRP) [dBm]	Margin [dB]		Horizontal		Vertical		Remarks		
	HOR	VER	HOR	VER				HOR	VER		HOR	VER	HOR	VER	Rx Ant.	Turn		Rx Ant.	Turn
															Height [cm]	Table [deg.]		Height [cm]	Table [deg.]
3760.00	44.4	44.5	-57.7	-58.3	4.7	11.8	0.0	-50.6	-51.2	-13.0	37.6	38.2	100	298	100	212			

Calculation Result = SG Reading - Tx Cable Loss + Tx Antenna Gain - Tx Antenna Attenuator Loss

Rx-ANTENNA : Biconical Antenna(30M-300MHz), Logperiodic Antenna(300M-1000MHz), Horn Antenna(1G-40GHz)

Tx-ANTENNA : 120MHz tuned Dipole Antenna(30M-120MHz), Dipole Antenna(120M-1000MHz), Horn Antenna(1G-40GHz)

Other frequency noises omitted in this report were not seen or had enough margin (more than 20dB).

Detector : S/A PK(RBW:1MHz/VBW:3MHz)

Tx 1909.8MHz

Frequency [MHz]	Rx SA/TR Reading [dBuV]		Tx SG Reading [dBm]		Tx Cable Loss [dB]	Tx Ant. Gain [dBi]	Tx Ant. Atten. Loss [dB]	Result (EIRP) [dBm]		Limit (EIRP) [dBm]	Margin [dB]		Horizontal		Vertical		Remarks		
	HOR	VER	HOR	VER				HOR	VER		HOR	VER	HOR	VER	Rx Ant.	Turn		Rx Ant.	Turn
															Height [cm]	Table [deg.]		Height [cm]	Table [deg.]
3819.60	44.0	44.6	-57.6	-57.1	4.8	11.8	0.0	-50.6	-50.1	-13.0	37.6	37.1	100	305	100	212			

Calculation Result = SG Reading - Tx Cable Loss + Tx Antenna Gain - Tx Antenna Attenuator Loss

Rx-ANTENNA : Biconical Antenna(30M-300MHz), Logperiodic Antenna(300M-1000MHz), Horn Antenna(1G-40GHz)

Tx-ANTENNA : 120MHz tuned Dipole Antenna(30M-120MHz), Dipole Antenna(120M-1000MHz), Horn Antenna(1G-40GHz)

Other frequency noises omitted in this report were not seen or had enough margin (more than 20dB).

Detector : S/A PK(RBW:1MHz/VBW:3MHz)

Spurious Emission (Radiated)
W-CDMA Band II

Report No. 32FE0253-HO
Test place Head Office EMC Lab. No.3 Semi Anechoic Chamber
Date 03/01/2012
Temperature / Humidity 23deg. C / 32% RH
Engineer Katsunori Okai
Mode Tx W-CDMA(RMC12.2kbps), All Up Bits

Tx: 1852.4MHz

Frequency [MHz]	Rx SA/TR Reading [dBuV]		Tx SG Reading [dBm]		Tx Cable Loss [dB]	Tx Ant. Gain [dBi]	Tx Ant. Atten. Loss [dB]	Result (EIRP) [dBm]		Limit (EIRP) [dBm]	Margin [dB]		Horizontal		Vertical		Remarks
	HOR	VER	HOR	VER				HOR	VER		HOR	VER	Rx Ant. Height [cm]	Turn Table [deg.]	Rx Ant. Height [cm]	Turn Table [deg.]	
	3704.80	49.1	50.8	-52.8				-51.7	4.7		11.9	0.0	-45.6	-44.6	-13.0	32.6	

Calculation Result = SG Reading - Tx Cable Loss + Tx Antenna Gain - Tx Antenna Attenuator Loss
Rx-ANTENNA : Biconical Antenna(30M-300MHz), Logperiodic Antenna(300M-1000MHz), Horn Antenna(1G-40GHz)
Tx-ANTENNA : 120MHz tuned Dipole Antenna(30M-120MHz), Dipole Antenna(120M-1000MHz), Horn Antenna(1G-40GHz)
Other frequency noises omitted in this report were not seen or had enough margin (more than 20dB).
Detector : S/A PK(RBW:1MHz/VBW:3MHz)

Tx: 1880.0MHz

Frequency [MHz]	Rx SA/TR Reading [dBuV]		Tx SG Reading [dBm]		Tx Cable Loss [dB]	Tx Ant. Gain [dBi]	Tx Ant. Atten. Loss [dB]	Result (EIRP) [dBm]		Limit (EIRP) [dBm]	Margin [dB]		Horizontal		Vertical		Remarks
	HOR	VER	HOR	VER				HOR	VER		HOR	VER	Rx Ant. Height [cm]	Turn Table [deg.]	Rx Ant. Height [cm]	Turn Table [deg.]	
	3760.00	50.6	49.3	-51.5				-53.5	4.7		11.8	0.0	-44.4	-46.4	-13.0	31.4	

Calculation Result = SG Reading - Tx Cable Loss + Tx Antenna Gain - Tx Antenna Attenuator Loss
Rx-ANTENNA : Biconical Antenna(30M-300MHz), Logperiodic Antenna(300M-1000MHz), Horn Antenna(1G-40GHz)
Tx-ANTENNA : 120MHz tuned Dipole Antenna(30M-120MHz), Dipole Antenna(120M-1000MHz), Horn Antenna(1G-40GHz)
Other frequency noises omitted in this report were not seen or had enough margin (more than 20dB).
Detector : S/A PK(RBW:1MHz/VBW:3MHz)

Tx: 1907.6MHz

Frequency [MHz]	Rx SA/TR Reading [dBuV]		Tx SG Reading [dBm]		Tx Cable Loss [dB]	Tx Ant. Gain [dBi]	Tx Ant. Atten. Loss [dB]	Result (EIRP) [dBm]		Limit (EIRP) [dBm]	Margin [dB]		Horizontal		Vertical		Remarks
	HOR	VER	HOR	VER				HOR	VER		HOR	VER	Rx Ant. Height [cm]	Turn Table [deg.]	Rx Ant. Height [cm]	Turn Table [deg.]	
	3815.20	49.9	48.6	-51.7				-53.1	4.8		11.8	0.0	-44.7	-46.0	-13.0	31.7	

Calculation Result = SG Reading - Tx Cable Loss + Tx Antenna Gain - Tx Antenna Attenuator Loss
Rx-ANTENNA : Biconical Antenna(30M-300MHz), Logperiodic Antenna(300M-1000MHz), Horn Antenna(1G-40GHz)
Tx-ANTENNA : 120MHz tuned Dipole Antenna(30M-120MHz), Dipole Antenna(120M-1000MHz), Horn Antenna(1G-40GHz)
Other frequency noises omitted in this report were not seen or had enough margin (more than 20dB).
Detector : S/A PK(RBW:1MHz/VBW:3MHz)

APPENDIX 2: Test instruments

EMI test equipment (1/2)

Control No.	Instrument	Manufacturer	Model No	Serial No	Test Item	Calibration Date * Interval(month)
MURC-03	Radio Communication Analyzer	Anritsu	MT8815B	6200711471	RE	2011/11/26 * 12
MAEC-03	Semi Anechoic Chamber(NSA)	TDK	Semi Anechoic Chamber 3m	DA-10005	RE	2012/02/24 * 12
MOS-13	Thermo-Hygrometer	Custom	CTH-180	-	RE	2012/02/06 * 12
MJM-06	Measure	PROMART	SEN1955	-	RE	
COTS-MEMI	EMI measurement program	TSJ	TEPTO-DV	-	RE	-
MSA-04	Spectrum Analyzer	Agilent	E4448A	US44300523	RE	2011/04/08 * 12
MBA-03	Biconical Antenna	Schwarzbeck	BBA9106	1915	RE	2011/10/15 * 12
MLA-03	Logperiodic Antenna	Schwarzbeck	USLP9143	174	RE	2011/10/15 * 12
MCC-51	Coaxial cable	UL Japan	-	-	RE	2011/07/15 * 12
MAT-09	Attenuator(6dB)	Weinschel Corp	2	BK7973	RE	2011/11/02 * 12
MPA-13	Pre Amplifier	SONOMA INSTRUMENT	310	260834	RE	2011/03/04 * 12
MHA-20	Horn Antenna 1-18GHz	Schwarzbeck	BBHA9120D	258	RE	2011/05/23 * 12
MCC-133	Microwave Cable	HUBER+SUHNER	SUCOFLEX104	336164/4(1m) / 340640(5m)	RE	2011/09/07 * 12
MPA-11	MicroWave System Amplifier	Agilent	83017A	MY39500779	RE	2011/03/10 * 12
MHA-16	Horn Antenna 15-40GHz	Schwarzbeck	BBHA9170	BBHA9170306	RE	2011/05/23 * 12
MHF-06	High Pass Filter 3.5-24GHz	TOKIMEC	TF323DCA	601	RE	2011/05/16 * 12
MHA-21	Horn Antenna 1-18GHz	Schwarzbeck	BBHA9120D	9120D-557	RE	2011/08/11 * 12
MCC-130	Microwave Cable(1-33GHz)	HUBER+SUHNER	SF103/11PC3.5-31/11PC3.5-31/8.0m	54308/3	RE	2012/01/05 * 12
MSG-09	Signal Generator	Wiltron	68247B	674005	RE	2012/02/13 * 12
MURC-02	Wireless Communication Test Set	Agilent	E5515C	GB47050683	RE	2011/11/26 * 12

The expiration date of the calibration is the end of the expired month.

All equipment is calibrated with valid calibrations. Each measurement data is traceable to the national or international standards.

As for some calibrations performed after the tested dates, those test equipment have been controlled by means of an unbroken chains of calibrations.

Test Item:

RE: Radiated Emission

UL Japan, Inc.

Head Office EMC Lab.

4383-326 Asama-cho, Ise-shi, Mie-ken 516-0021 JAPAN

Telephone : +81 596 24 8116

Facsimile : +81 596 24 8124