



EMI TEST REPORT

Test Report No. : 32FE0253-HO-C

Applicant : SAMSUNG ELECTRONICS CO., LTD.
Type of Equipment : GPRS850/1900, EDGE850/1900, WCDMA2,
WCDMA5 Tablet with 802.11bgn, BT3.0+EDR
Model No. : GT-P5100
Test regulation : FCC Part 15 Subpart B: 2012 Class B
FCC ID : A3LGTP5100
Test Result : Complied

1. This test report shall not be reproduced in full or partial, without the written approval of UL Japan, Inc.
2. The results in this report apply only to the sample tested.
3. This sample tested is in compliance with the limits of the above regulation.
4. The test results in this test report are traceable to the national or international standards.
5. This test report must not be used by the customer to claim product certification, approval, or endorsement by NVLAP, NIST, or any agency of the Federal Government.

Date of test: February 16 and 17, 2012

Representative test engineer: 
Takumi Shimada
Engineer of WiSE Japan,
UL Verification Service

Approved by: 
Takahiro Hatakeda
Leader of WiSE Japan,
UL Verification Service



NVLAP LAB CODE: 200572-0

This laboratory is accredited by the NVLAP LAB CODE 200572-0, U.S.A. The tests reported herein have been performed in accordance with its terms of accreditation.
*As for the range of Accreditation in NVLAP, you may refer to the WEB address,
<http://www.ul.com/japan/jpn/pages/services/emc/about/mark1/index.jsp#nvlap>

UL Japan, Inc.

Head Office EMC Lab.

4383-326 Asama-cho, Ise-shi, Mie-ken 516-0021 JAPAN

Telephone : +81 596 24 8116

Facsimile : +81 596 24 8124

13-EM-F0429

CONTENTS	PAGE
SECTION 1: Customer information	3
SECTION 2: Equipment under test (E.U.T.)	3
SECTION 3: Test specification, procedures & results	5
SECTION 4: Operation of E.U.T. during testing	8
SECTION 5: Conducted Emission	10
SECTION 6: Radiated Emission	11
APPENDIX 1: Data of EMI test	12
Conducted Emission	12
Radiated Emission	14
APPENDIX 2: Test instruments	18
APPENDIX 3: Photographs of test setup.....	19
Conducted Emission	19
Radiated Emission	21
Worst Case Position (Horizontal: X-axis/ Vertical:X-axis)	23

SECTION 1: Customer information

Company Name : SAMSUNG ELECTRONICS CO., LTD.
Address : 416, MAETAN 3-DONG, YEONGTONG-GU SUWON-CITY,
GYEONGGI-DO 443-742, SOUTH KOREA

SECTION 2: Equipment under test (E.U.T.)

2.1 Identification of E.U.T.

Type of Equipment : GPRS850/1900, EDGE850/1900, WCDMA2, WCDMA5 Tablet with
802.11bgn, BT3.0+EDR
Model No. : GT-P5100
Serial No. : Refer to Section 4, Clause 4.2
Rating : DC5.0V
Receipt Date of Sample : February 6, 2012
Modification of EUT : No Modification by the test lab

2.2 Product Description

Maximum frequency generated or used by the EUT: 26MHz (oscillator), 1GHz (processor)

Radio Specification

Bluetooth

Equipment Type	Transceiver
Frequency of Operation	2402-2480MHz
Type of Modulation	FHSS
Bandwidth & Channel spacing	1MHz & 1MHz
Antenna Type	PIFA
Antenna Gain	-0.31 dBi (MAX)

WLAN (IEEE802.11b/g/n-20)

Equipment Type	Transceiver
Frequency of Operation	2412-2462MHz
Type of Modulation	DSSS, OFDM
Bandwidth & Channel spacing	20MHz & 5MHz
Antenna Type	PIFA
Antenna Gain	-0.31 dBi (MAX)

UL Japan, Inc.

Head Office EMC Lab.

4383-326 Asama-cho, Ise-shi, Mie-ken 516-0021 JAPAN

Telephone : +81 596 24 8116

Facsimile : +81 596 24 8124

GSM

Equipment Type	Transceiver
Frequency of Operation	[Up Link] GSM850: 824 – 849MHz PCS: 1850 – 1910MHz [Down Link] GSM850: 869 – 894MHz PCS: 1930 – 1990MHz
Type of Modulation	GMSK , 8PSK
Antenna Type	PIFA
Antenna Gain	GSM850: 824-849MHz: -4.63dBi (MAX) 869-894MHz: -2.35dBi (MAX) PCS: 1850-1910MHz: -5.1dBi (MAX) 1930-1990MHz: -5.55dBi (MAX)

W-CDMA

Equipment Type	Transceiver
Frequency of Operation	[Up Link] Band V: 824 – 849MHz Band II: 1850 – 1910MHz [Down Link] Band V: 869 – 894MHz Band II: 1930 – 1990MHz
Type of Modulation	QPSK
Antenna Type	PIFA
Antenna Gain	Band V: 824-849MHz: -4.63dBi (MAX) 869-894MHz: -2.35dBi (MAX) Band II: 1850-1910MHz: -5.1dBi (MAX) 1930-1900MHz: -5.55dBi (MAX)

UL Japan, Inc.

Head Office EMC Lab.

4383-326 Asama-cho, Ise-shi, Mie-ken 516-0021 JAPAN

Telephone : +81 596 24 8116

Facsimile : +81 596 24 8124

SECTION 3: Test specification, procedures & results

3.1 Test specification

Test Specification : FCC Part 15 Subpart B: 2012, final revised on February 1, 2012
Title : FCC 47CFR Part15 Radio Frequency Device
Subpart B Unintentional Radiators

3.2 Procedures and results

Item	Test Procedure	Limits	Deviation	Worst margin	Result
Conducted emission	ANSI C63.4: 2003 7. AC powerline conducted emission measurements	Class B	N/A	[QP] 13.7dB 0.19037MHz, L [AV] 18.8dB 13.32334MHz, L	Complied
Radiated emission	ANSI C63.4: 2003 8. Radiated emission measurements	Class B	N/A	4.8dB 71.997MHz, QP Horizontal	Complied

*Note: UL Japan, Inc's EMI Work Procedure 13-EM-W0420.

3.3 Addition to standard

No addition, exclusion nor deviation has been made from the standard.

3.4 Uncertainty

EMI

The following uncertainties have been calculated to provide a confidence level of 95% using a coverage factor k=2.

Test room (semi-anechoic chamber)	Conducted emission (+dB)
	150kHz-30MHz
No.1	3.5dB
No.2	3.6dB
No.3	3.6dB
No.4	3.6dB

Test room (semi-anechoic chamber)	Radiated emission						
	(3m*)(+dB)				(1m*)(+dB)		(0.5m*)(+dB)
	9kHz -30MHz	30MHz -300MHz	300MHz -1GHz	1GHz -10GHz	10GHz -18GHz	18GHz -26.5GHz	26.5GHz -40GHz
No.1	4.2dB	5.0dB	5.1dB	4.7dB	5.7dB	4.4dB	4.3dB
No.2	4.1dB	5.2dB	5.1dB	4.8dB	5.6dB	4.3dB	4.2dB
No.3	4.5dB	5.0dB	5.2dB	4.8dB	5.6dB	4.5dB	4.2dB
No.4	4.7dB	5.2dB	5.2dB	4.8dB	5.6dB	5.1dB	4.2dB

*3m/1m/0.5m = Measurement distance

Conducted Emission test

The data listed in this test report has enough margin, more than the site margin.

Radiated emission test(3m)

The data listed in this report meets the limits unless the uncertainty is taken into consideration.

UL Japan, Inc.

Head Office EMC Lab.

4383-326 Asama-cho, Ise-shi, Mie-ken 516-0021 JAPAN

Telephone : +81 596 24 8116

Facsimile : +81 596 24 8124

3.5 Test Location

UL Japan, Inc. Head Office EMC Lab. *NVLAP Lab. code: 200572-0
4383-326 Asama-cho, Ise-shi, Mie-ken 516-0021 JAPAN
Telephone : +81 596 24 8116 Facsimile : +81 596 24 8124

	FCC Registration Number	IC Registration Number	Width x Depth x Height (m)	Size of reference ground plane (m) / horizontal conducting plane	Other rooms
No.1 semi-anechoic chamber	313583	2973C-1	19.2 x 11.2 x 7.7m	7.0 x 6.0m	No.1 Power source room
No.2 semi-anechoic chamber	655103	2973C-2	7.5 x 5.8 x 5.2m	4.0 x 4.0m	-
No.3 semi-anechoic chamber	148738	2973C-3	12.0 x 8.5 x 5.9m	6.8 x 5.75m	No.3 Preparation room
No.3 shielded room	-	-	4.0 x 6.0 x 2.7m	N/A	-
No.4 semi-anechoic chamber	134570	2973C-4	12.0 x 8.5 x 5.9m	6.8 x 5.75m	No.4 Preparation room
No.4 shielded room	-	-	4.0 x 6.0 x 2.7m	N/A	-
No.5 semi-anechoic chamber	-	-	6.0 x 6.0 x 3.9m	6.0 x 6.0m	-
No.6 shielded room	-	-	4.0 x 4.5 x 2.7m	4.75 x 5.4 m	-
No.6 measurement room	-	-	4.75 x 5.4 x 3.0m	4.75 x 4.15 m	-
No.7 shielded room	-	-	4.7 x 7.5 x 2.7m	4.7 x 7.5m	-
No.8 measurement room	-	-	3.1 x 5.0 x 2.7m	N/A	-
No.9 measurement room	-	-	8.0 x 4.5 x 2.8m	2.0 x 2.0m	-
No.10 measurement room	-	-	2.6 x 2.8 x 2.5m	2.4 x 2.4m	-
No.11 measurement room	-	-	3.1 x 3.4 x 3.0m	2.4 x 3.4m	-

* Size of vertical conducting plane (for Conducted Emission test) : 2.0 x 2.0m for No.1, No.2, No.3, and No.4 semi-anechoic chambers and No.3 and No.4 shielded rooms.

3.6 Data of EMI, Test instruments, and Test set up

Refer to APPENDIX.

SECTION 4: Operation of E.U.T. during testing

4.1 Operating modes

Mode	Remarks
Charge mode	-
USB mode	-

4.2 Configuration and peripherals

Charge mode

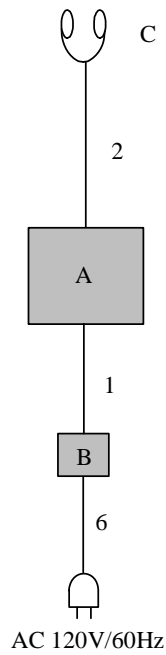

USB mode

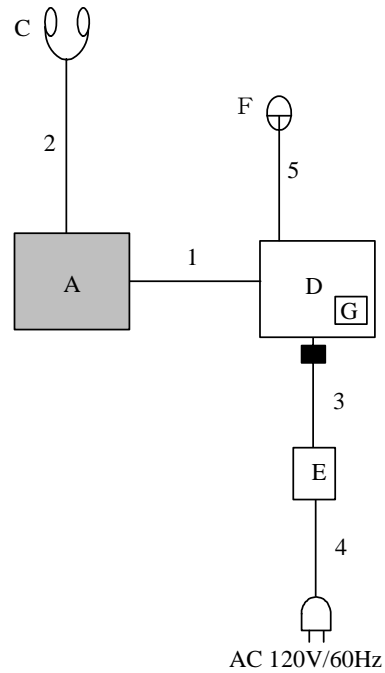

■ : Ferrite Core (Standard Attachment)

*Cabling and setup were taken into consideration and test data was taken under worse case conditions.

UL Japan, Inc.

Head Office EMC Lab.

4383-326 Asama-cho, Ise-shi, Mie-ken 516-0021 JAPAN

Telephone : +81 596 24 8116

Facsimile : +81 596 24 8124

Description of EUT and Support equipment

No.	Item	Model number	Serial number	Manufacturer	Remarks
A	GPRS850/1900, EDGE850/1900, WCDMA2, WCDMA5 Tablet with 802.11bgn, BT3.0+EDR	GT-P5100	R31C10LKC6R	SAMSUNG	EUT
B	AC Adaptor	ETA-P11X	-	SAMSUNG	EUT
C	Ear phone	-	-	SAMSUNG	-
D	Laptop PC	T61	L3R2056	Lenovo	-
E	AC Adaptor	92P1160	11S92P1160Z1ZBG H7B99A8	Lenovo	-
F	Mouse	M-UB48	LZE02601001	Logitech	-
G	PC Card	PCFDC IV-ADP	CT41098540TD	IO DATA	-

List of cables used

No.	Name	Length (m)	Shield		Remarks
			Cable	Connector	
1	USB Cable	1.0	Shielded	Shielded	-
2	Ear phone Cable	1.2	Unshielded	Unshielded	-
3	DC Cable	1.8	Unshielded	Unshielded	-
4	AC Cable	0.9	Unshielded	Unshielded	-
5	Mouse Cable	0.75	Shielded	Shielded	-
6	AC Cable	0.9	Unshielded	Unshielded	-

UL Japan, Inc.

Head Office EMC Lab.

4383-326 Asama-cho, Ise-shi, Mie-ken 516-0021 JAPAN

Telephone : +81 596 24 8116

Facsimile : +81 596 24 8124

SECTION 5: Conducted Emission

5.1 Operating environment

Test place : No.4 semi anechoic chamber.
Temperature : See data
Humidity : See data

5.2 Test configuration

EUT was placed on a urethane platform of nominal size, 1.0m by 1.5m, raised 0.8m above the conducting ground plane. The rear of tabletop was located 40cm to the vertical conducting plane. The rear of EUT and its peripherals was aligned and flushed with rear of tabletop. All other surfaces of tabletop were at least 80cm from any other grounded conducting surface. EUT was located 80cm from the LISN/AMN. They were folded back and forth forming a bundle 30cm to 40cm long and were hanged at a 40cm height to the ground plane. Each EUT current-carrying power lead, except the ground (safety) lead, was individually connected through a LISN/AMN to the input power source. All unused 50 ohm connectors of the LISN/AMN were resistivity terminated in 50 ohm when not connected to the measuring equipment. Photographs of the set up are shown in Appendix 3.

Frequency range : 0.15 MHz-30MHz
EUT position : Table top
EUT operation mode : See Clause 4.1

5.3 Test procedure

The AC Mains Terminal Continuous disturbance Voltage has been measured with the EUT within a semi anechoic chamber. The EUT was connected to a Line Impedance Stabilization Network (LISN)/ Artificial Mains network (AMN). An overview sweep with peak detection has been performed. The measurements have been performed with a quasi-peak detector and if required, with an average detector.

The conducted emission measurements were made with the following detector function of the test receiver.

Detector Type : Quasi-Peak and Average
IF Bandwidth : 9 kHz

5.4 Test result

Summary of the test results: Pass

Date: February 17, 2012

Test engineer: Takumi Shimada

UL Japan, Inc.

Head Office EMC Lab.

4383-326 Asama-cho, Ise-shi, Mie-ken 516-0021 JAPAN

Telephone : +81 596 24 8116

Facsimile : +81 596 24 8124

SECTION 6: Radiated Emission

6.1 Operating environment

Test place : No.4 semi anechoic chamber
Temperature : See data
Humidity : See data

6.2 Test configuration

EUT was placed on a urethane platform of nominal size, 1.0m by 1.5m, raised 0.8m above the conducting ground plane. The EUT was set on the edge of the tabletop.
Test was made with the antenna positioned in both the horizontal and vertical planes of polarization. The measurement antenna was varied in height above the conducting ground plane to obtain the maximum signal strength.
Photographs of the set up are shown in Appendix 3.

6.3 Test conditions

Frequency range : 30MHz-300MHz (Biconical antenna) / 300MHz-1000MHz (Logperiodic antenna)
1000MHz -10000MHz (Horn antenna)
Test distance : 3m
EUT position : Table top
EUT operation mode : See Clause 4.1

6.4 Test procedure

The height of the measuring antenna varied between 1 and 4m and EUT was rotated a full revolution in order to obtain the maximum value of the electric field intensity.

The measurements were performed for both vertical and horizontal antenna polarization with the Test Receiver, or the Spectrum Analyzer.

The radiated emission measurements were made with the following detector function of the test receiver and the Spectrum analyzer.

Frequency	Below 1GHz	Above 1GHz
Instrument used	Test Receiver	Spectrum Analyzer
IF Bandwidth	QP: BW 120kHz	PK: RBW:1MHz/VBW: 3MHz AV *1): RBW:1MHz/VBW:10Hz

*1) When using Spectrum analyzer, the test was made with adjusting span to zero by using peak hold.

- The noise levels were confirmed at each position of X, Y and Z axes of EUT to see the position of maximum noise, and the test was made at representative X-axis since no difference was found among each position.

6.5 Test result

Summary of the test results: Pass

Date: February 16 and 17, 2012

Test engineer: Takumi Shimada

UL Japan, Inc.

Head Office EMC Lab.

4383-326 Asama-cho, Ise-shi, Mie-ken 516-0021 JAPAN

Telephone : +81 596 24 8116

Facsimile : +81 596 24 8124

APPENDIX 1: Data of EMI test

Conducted Emission
Charge mode

DATA OF CONDUCTED EMISSION TEST

UL Japan, Inc. Head Office EMC Lab. No.4 Semi Anechoic Chamber
Date : 2012/02/17

Report No. : 32FE0253-HO

Temp./Humi. : 23 deg. C / 32% RH
Engineer : Takumi Shimada

Mode / Remarks : Charge mode

LIMIT : FCC15.107(a) QP ClassB
FCC15.107(a) AV ClassB

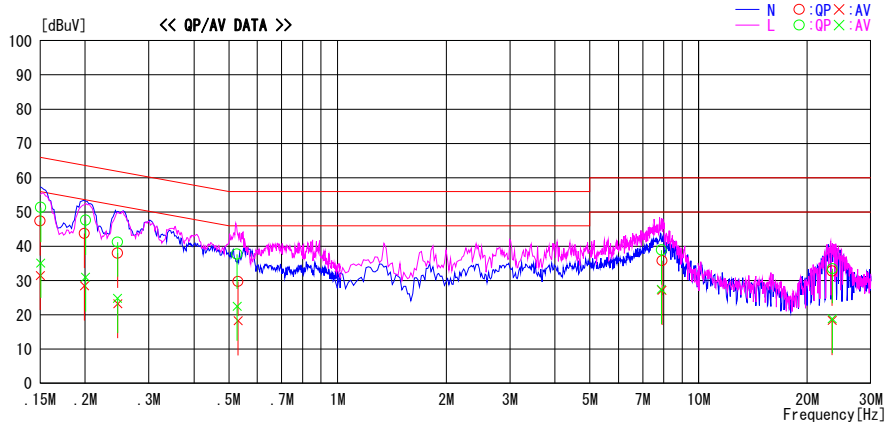

Frequency [MHz]	Reading Level		Corr. Factor [dB]	Results		Limit		Margin		Phase	Comment
	QP [dBuV]	AV [dBuV]		QP [dBuV]	AV [dBuV]	QP [dBuV]	AV [dBuV]	QP [dB]	AV [dB]		
0.15000	34.1	18.2	13.3	47.4	31.5	66.0	56.0	18.6	24.5	N	
0.19910	30.4	15.1	13.3	43.7	28.4	63.6	53.6	19.9	25.2	N	
0.24591	24.7	9.9	13.3	38.0	23.2	61.9	51.9	23.9	28.7	N	
0.53001	16.4	4.9	13.3	29.7	18.2	56.0	46.0	26.3	27.8	N	
7.92303	21.8	13.1	14.0	35.8	27.1	60.0	50.0	24.2	22.9	N	
23.43735	17.9	3.5	14.8	32.7	18.3	60.0	50.0	27.3	31.7	N	
0.15050	38.0	21.8	13.3	51.3	35.1	66.0	56.0	14.7	20.9	L	
0.20056	34.3	17.7	13.3	47.6	31.0	63.6	53.6	16.0	22.6	L	
0.24573	27.9	11.5	13.3	41.2	24.8	61.9	51.9	20.7	27.1	L	
0.52659	24.4	9.2	13.3	37.7	22.5	56.0	46.0	18.3	23.5	L	
7.88700	24.9	13.4	14.0	38.9	27.4	60.0	50.0	21.1	22.6	L	
23.45055	18.6	4.1	14.8	33.4	18.9	60.0	50.0	26.6	31.1	L	

CHART:WITH FACTOR, Peak hold data. CALCULATION: RESULT[dBuV]=READING[dBuV]+C. F[dB] (LISN LOSS+CABLE LOSS)
Except for the above table : adequate margin data below the limits.

*The limit is rounded down to one decimal place.

*The test result is rounded off to one or two decimal places, so some differences might be observed.

Conducted Emission USB Mode

DATA OF CONDUCTED EMISSION TEST

UL Japan, Inc. Head Office EMC Lab. No.4 Semi Anechoic Chamber
Date : 2012/02/17

Report No. : 32FE0253-HO

Temp./Humi. : 23 deg. C / 32% RH
Engineer : Takumi Shimada

Mode / Remarks : USB mode

LIMIT : FCC15.107(a) QP ClassB
FCC15.107(a) AV ClassB

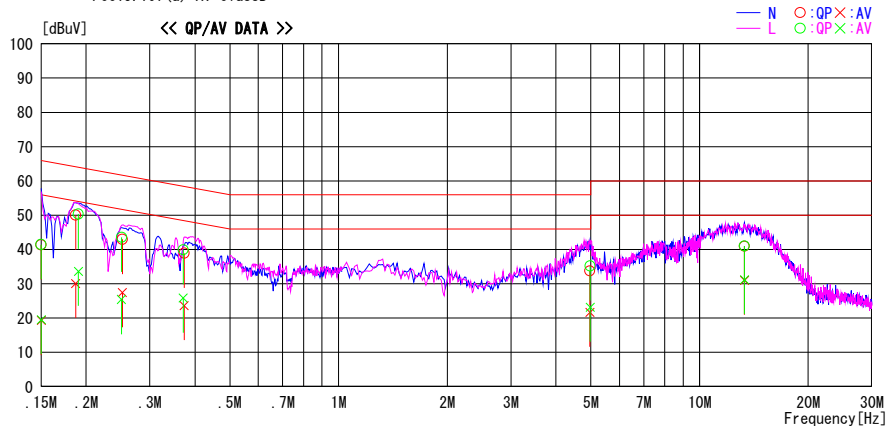

Frequency [MHz]	Reading Level		Corr. Factor [dB]	Results		Limit		Margin		Phase	Comment
	QP [dBuV]	AV [dBuV]		QP [dBuV]	AV [dBuV]	QP [dBuV]	AV [dBuV]	QP [dB]	AV [dB]		
0.15000	28.0	6.0	13.3	41.3	19.3	66.0	56.0	24.7	36.7	N	
0.18679	36.7	16.8	13.3	50.0	30.1	64.2	54.2	14.2	24.1	N	
0.25166	29.6	14.1	13.3	42.9	27.4	61.7	51.7	18.8	24.3	N	
0.37361	25.6	10.3	13.3	38.9	23.6	58.4	48.4	19.5	24.8	N	
4.96756	20.1	8.0	13.7	33.8	21.7	56.0	46.0	22.2	24.3	N	
13.32410	26.6	16.7	14.3	40.9	31.0	60.0	50.0	19.1	19.0	N	
0.15000	28.1	6.2	13.3	41.4	19.5	66.0	56.0	24.6	36.5	L	
0.19037	37.0	20.3	13.3	50.3	33.6	64.0	54.0	13.7	20.4	L	
0.25057	30.2	12.1	13.3	43.5	25.4	61.7	51.7	18.2	26.3	L	
0.37110	26.6	12.5	13.3	39.9	25.8	58.5	48.5	18.6	22.7	L	
4.97965	21.5	9.4	13.7	35.2	23.1	56.0	46.0	20.8	22.9	L	
13.32334	26.7	16.9	14.3	41.0	31.2	60.0	50.0	19.0	18.8	L	

CHART: WITH FACTOR, Peak hold data. CALCULATION: RESULT [dBuV] = READING [dBuV] + C.F [dB] (LISN LOSS + CABLE LOSS)
Except for the above table : adequate margin data below the limits.

*The limit is rounded down to one decimal place.
*The test result is rounded off to one or two decimal places, so some differences might be observed.

Radiated Emission Charge mode

DATA OF RADIATED EMISSION TEST

UL Japan, Inc. Head Office EMC Lab. No. 4 Semi Anechoic Chamber
Date : 2012/02/17

Report No. : 32FE0253-H0

Temp./Humi. : 23 deg. C / 32% RH
Engineer : Takumi Shimada

Mode / Remarks : Charge mode

LIMIT : FCC15.109(a) 3m, below 1GHz:QP, above 1GHz:PK
All other spurious emissions were less than 20dB for the limit.

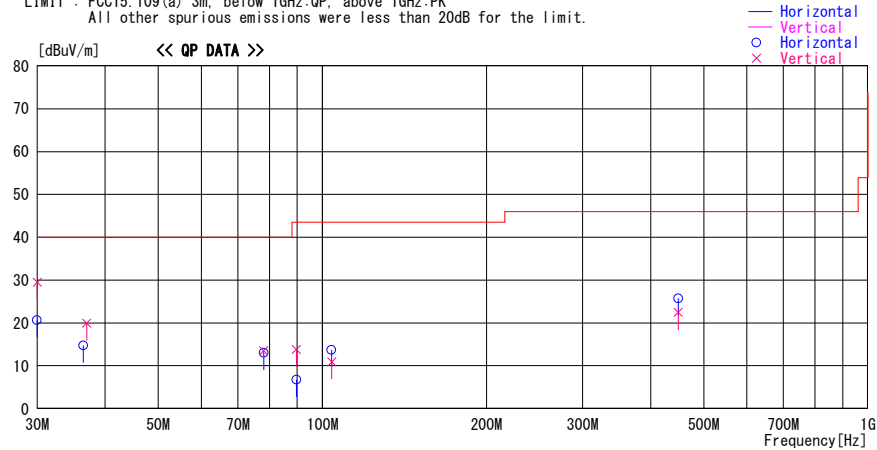

Frequency [MHz]	Reading [dBuV]	DET	Antenna	Loss&	Level [dBuV/m]	Angle [Deg]	Height [cm]	Polar.	Limit [dBuV/m]	Margin [dB]	Comment
			Factor [dB/m]	Gain [dB]							
30.000	26.6	QP	18.9	-24.9	20.6	130	303	Hori.	40.0	19.4	
30.000	35.5	QP	18.9	-24.9	29.5	0	100	Vert.	40.0	10.5	
37.010	28.9	QP	15.9	-24.9	19.9	180	100	Vert.	40.0	20.1	
36.466	23.6	QP	16.0	-24.9	14.7	275	318	Hori.	40.0	25.3	
78.020	30.7	QP	6.5	-24.2	13.0	214	276	Hori.	40.0	27.0	
78.006	31.2	QP	6.5	-24.2	13.5	139	100	Vert.	40.0	26.5	
89.673	29.8	QP	8.2	-24.2	13.8	183	100	Vert.	43.5	29.7	
89.673	22.7	QP	8.2	-24.2	6.7	359	300	Hori.	43.5	36.8	
104.018	26.9	QP	10.8	-24.0	13.7	272	322	Hori.	43.5	29.8	
104.018	24.1	QP	10.8	-24.0	10.9	180	100	Vert.	43.5	32.6	
448.852	28.6	QP	18.3	-21.2	25.7	7	100	Hori.	46.0	20.3	
448.852	25.3	QP	18.3	-21.2	22.4	217	100	Vert.	46.0	23.6	

CHART:WITH FACTOR ANT TYPE: -30MHz:LOOP, 30-300MHz:BICONICAL, 300MHz-1000MHz:LOGPERIODIC, 1000MHz-:HORN
CALCULATION:RESULT = READING + ANT FACTOR + LOSS(CABLE+ATTEN.) - GAIN(AMP)

*The limit is rounded down to one decimal place.

*The test result is rounded off to one or two decimal places, so some differences might be observed.

Radiated Emission
USB mode

DATA OF RADIATED EMISSION TEST

UL Japan, Inc. Head Office EMC Lab. No. 4 Semi Anechoic Chamber
Date : 2012/02/17

Report No. : 32FE0253-H0
Temp./Humi. : 23 deg. C / 32% RH
Engineer : Takumi Shimada

Mode / Remarks : USB mode

LIMIT : FCC15.109(a) 3m, below 1GHz:QP, above 1GHz:PK
All other spurious emissions were less than 20dB for the limit.

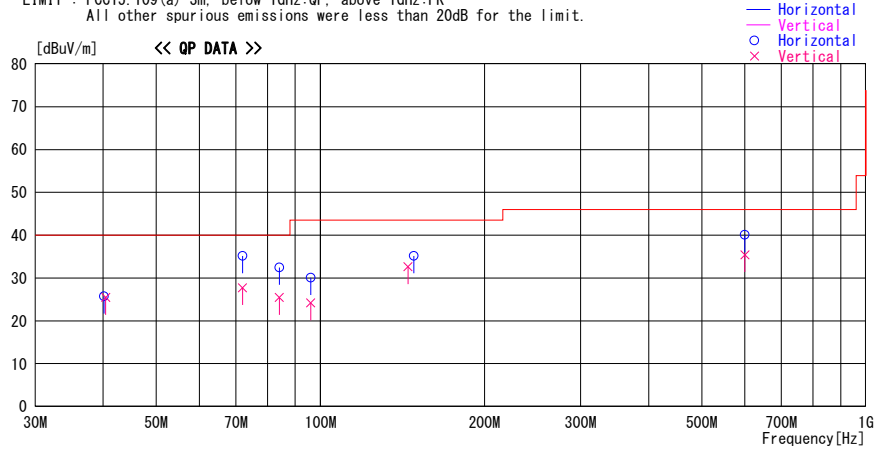

Frequency [MHz]	Reading [dBuV]	DET	Antenna		Level [dBuV/m]	Angle [Deg]	Height [cm]	Polar.	Limit [dBuV/m]	Margin [dB]	Comment
			Factor [dB/m]	Loss&Gain [dB]							
40.420	35.7	QP	14.6	-24.9	25.4	212	100	Vert.	40.0	14.6	
40.110	35.8	QP	14.8	-24.9	25.7	311	314	Hori.	40.0	14.3	
71.997	53.0	QP	6.6	-24.4	35.2	257	252	Hori.	40.0	4.8	
72.012	45.5	QP	6.6	-24.4	27.7	330	286	Vert.	40.0	12.3	
84.053	49.3	QP	7.2	-24.1	32.4	256	204	Hori.	40.0	7.6	
84.050	42.3	QP	7.2	-24.1	25.4	291	151	Vert.	40.0	14.6	
96.058	44.7	QP	9.5	-24.1	30.1	251	187	Hori.	43.5	13.4	
96.054	38.8	QP	9.5	-24.1	24.2	246	100	Vert.	43.5	19.3	
144.740	41.2	QP	14.8	-23.4	32.6	2	100	Vert.	43.5	10.9	
148.523	43.6	QP	15.0	-23.4	35.2	210	160	Hori.	43.5	8.3	
599.987	40.0	QP	20.6	-20.5	40.1	201	100	Hori.	46.0	5.9	
599.991	35.3	QP	20.6	-20.5	35.4	166	100	Vert.	46.0	10.6	

CHART: WITH FACTOR ANT TYPE: -30MHz: LOOP, 30-300MHz: BICONICAL, 300MHz-1000MHz: LOGPERIODIC, 1000MHz-: HORN
CALCULATION: RESULT = READING + ANT FACTOR + LOSS (CABLE+ATTEN.) - GAIN (AMP)

*The limit is rounded down to one decimal place.
*The test result is rounded off to one or two decimal places, so some differences might be observed.

Radiated Emission
Charge mode

DATA OF RADIATED EMISSION TEST

UL Japan, Inc. Head Office EMC Lab. No. 4 Semi Anechoic Chamber
Date : 2012/02/16

Report No. : 32FE0253-H0

Temp./Humi. : 23 deg. C / 32% RH
Engineer : Takumi Shimada

Mode / Remarks : Charge mode

LIMIT : FCC15.109(a) 3m, below 1GHz:QP, above 1GHz:PK
FCC15.109(a) 3m, below 1GHz:QP, above 1GHz:AV

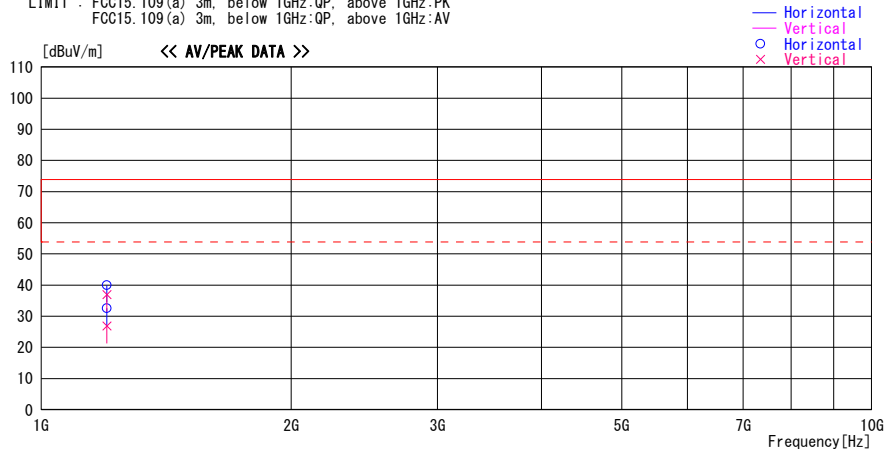

Frequency [MHz]	Reading [dBuV]	DET	Antenna	Loss&	Level	Angle	Height	Polar.	Limit	Margin	Comment
			Factor	Gain							
			[dB/m]	[dB]	[dBuV/m]	[Deg]	[cm]		[dBuV/m]	[dB]	
1200.000	47.9	PK	24.5	-32.4	40.0	0	100	Hori.	73.9	33.9	
1200.000	44.9	PK	24.5	-32.4	37.0	309	100	Vert.	73.9	36.9	
1200.000	40.5	AV	24.5	-32.4	32.6	0	100	Hori.	53.9	21.3	
1200.000	34.7	AV	24.5	-32.4	26.8	309	100	Vert.	53.9	27.1	

CHART:WITH FACTOR ANT TYPE: -30MHz:LOOP, 30-300MHz:BICONICAL, 300MHz-1000MHz:LOGPERIODIC, 1000MHz-:HORN
CALCULATION:RESULT = READING + ANT FACTOR + LOSS(CABLE+ATTEN.) - GAIN(AMP)

*The limit is rounded down to one decimal place.
*The test result is rounded off to one or two decimal places, so some differences might be observed.

Radiated Emission
USB mode

DATA OF RADIATED EMISSION TEST

UL Japan, Inc. Head Office EMC Lab. No. 4 Semi Anechoic Chamber
Date : 2012/02/17

Report No. : 32FE0253-H0
Temp./Humi. : 23 deg.C / 32% RH
Engineer : Takumi Shimada

Mode / Remarks : USB mode

LIMIT : FCC15.109(a) 3m, below 1GHz:QP, above 1GHz:PK
FCC15.109(a) 3m, below 1GHz:QP, above 1GHz:AV

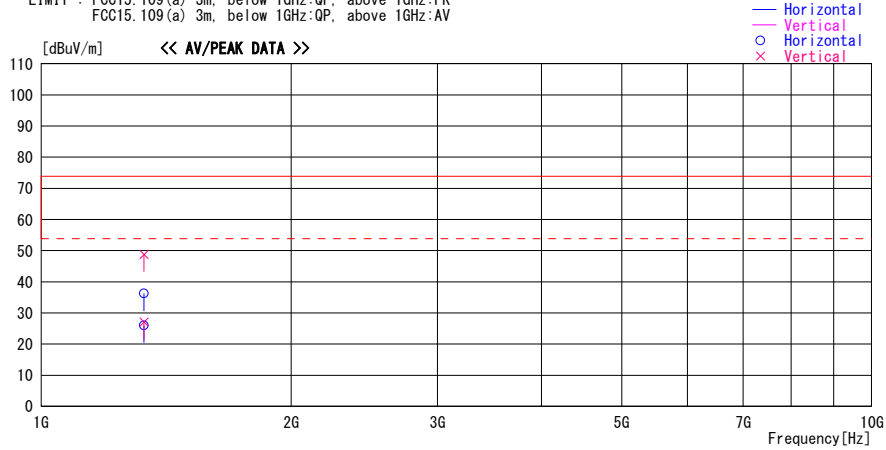

Frequency [MHz]	Reading [dBuV]	DET	Antenna	Loss&	Level [dBuV/m]	Angle [Deg]	Height [cm]	Polar.	Limit	Margin	Comment
			Factor [dB/m]	Gain [dB]					[dBuV/m]	[dB]	
1329.700	43.3	PK	24.8	-31.9	36.2	0	100	Hori.	73.9	37.7	
1329.700	55.9	PK	24.8	-31.9	48.8	357	100	Vert.	73.9	25.2	
1329.700	33.1	AV	24.8	-31.9	26.0	0	100	Hori.	53.9	27.9	
1329.700	34.1	AV	24.8	-31.9	27.0	357	100	Vert.	53.9	26.9	

CHART: WITH FACTOR ANT TYPE: -30MHz: LOOP, 30-300MHz: BICONICAL, 300MHz-1000MHz: LOGPERIODIC, 1000MHz-: HORN
CALCULATION: RESULT = READING + ANT FACTOR + LOSS (CABLE+ATTEN.) - GAIN (AMP)

*The limit is rounded down to one decimal place.
*The test result is rounded off to one or two decimal places, so some differences might be observed.

APPENDIX 2: Test instruments

EMI test equipment

Control No.	Instrument	Manufacturer	Model No	Serial No	Test Item	Calibration Date * Interval(month)
MAEC-04	Semi Anechoic Chamber(NSA)	TDK	Semi Anechoic Chamber 3m	DA-10005	RE/CE	2011/03/01 * 12
MOS-15	Thermo-Hygrometer	Custom	CTH-180	-	RE/CE	2012/02/06 * 12
MJM-07	Measure	PROMART	SEN1955	-	RE/CE	-
COTS-MEMI	EMI measurement program	TSJ	TEPTO-DV	-	RE/CE	-
MRENT-95	Spectrum Analyzer	Agilent	E4440A	MY46185823	RE/CE	2011/06/30 * 12
MTR-07	Test Receiver	Rohde & Schwarz	ESCI	100635	RE/CE	2011/10/19 * 12
MBA-05	Biconical Antenna	Schwarzbeck	BBA9106	1302	RE	2011/11/16 * 12
MLA-08	Logperiodic Antenna	Schwarzbeck	UKLP9140-A	N/A	RE	2011/11/16 * 12
MCC-50	Coaxial Cable	UL Japan	-	-	RE	2011/03/25 * 12
MAT-32	Attenuator(6dB)	TME	UFA-01	-	RE	2011/03/02 * 12
MPA-14	Pre Amplifier	SONOMA INSTRUMENT	310	260833	RE	2011/03/04 * 12
MHA-21	Horn Antenna 1-18GHz	Schwarzbeck	BBHA9120D	9120D-557	RE	2011/08/11 * 12
MCC-56	Microwave Cable	Suhner	SUCOFLEX104	270875/4(1m) / 284655(5m)	RE	2011/03/02 * 12
MPA-12	MicroWave System Amplifier	Agilent	83017A	MY39500780	RE	2011/03/10 * 12
MHF-06	High Pass Filter 3.5-24GHz	TOKIMEC	TF323DCA	601	RE	2011/05/16 * 12
MHA-17	Horn Antenna 15-40GHz	Schwarzbeck	BBHA9170	BBHA9170307	RE	2011/06/17 * 12
MLS-06	LISN(AMN)	Schwarzbeck	NSLK8127	8127363	CE(EUT)	2012/02/06 * 12
MTA-31	Terminator	TME	CT-01	-	CE	2012/01/11 * 12
MAT-67	Attenuator(13dB)	JFW Industries, Inc.	50FP-013H2 N	-	CE	2012/01/28 * 12
MCC-113	Coaxial cable	Fujikura/Suhner/TSJ	5D-2W(10m)/SFM141(5m)/421-010(1m)/sucoform141-PE(1m)/RFM-E121(Switcher)	-/04178	CE	2011/07/04 * 12

The expiration date of the calibration is the end of the expired month.

All equipment is calibrated with valid calibrations. Each measurement data is traceable to the national or international standards.

As for some calibrations performed after the tested dates, those test equipment have been controlled by means of an unbroken chains of calibrations.

Test Item:

CE: Conducted emission

RE: Radiated emission

UL Japan, Inc.

Head Office EMC Lab.

4383-326 Asama-cho, Ise-shi, Mie-ken 516-0021 JAPAN

Telephone : +81 596 24 8116

Facsimile : +81 596 24 8124