



FCC CFR47 PART 15 SUBPART C

BLUETOOTH

CERTIFICATION TEST REPORT

FOR

TABLET with GSM/GPRS/EDGE/WCDMA, 802.11bgn, BT3.0

MODEL NUMBER: GT-P3100

FCC ID: A3LGTP3100

REPORT NUMBER: 12114206-3

ISSUE DATE: FEBRUARY 17, 2012

Prepared for
SAMSUNG ELECTRONICS CO., LTD.
416, MAETAN 3-DONG, YEONGTONG-GU
SUWON CITY, GYEONGGI-DO 443-742
SOUTH KOREA

Prepared by
COMPLIANCE CERTIFICATION SERVICES (UL CCS)
47173 BENICIA STREET
FREMONT, CA 94538, U.S.A.
TEL: (510) 771-1000
FAX: (510) 661-0888



NVLAP LAB CODE 200065-0

Revision History

<u>Rev.</u>	<u>Issue Date</u>	<u>Revisions</u>	<u>Revised By</u>
--	02/17/12	Initial Issue	F. Ibrahim

TABLE OF CONTENTS

1. ATTESTATION OF TEST RESULTS	5
2. TEST METHODOLOGY	6
3. FACILITIES AND ACCREDITATION	6
4. CALIBRATION AND UNCERTAINTY	6
4.1. MEASURING INSTRUMENT CALIBRATION	6
4.2. SAMPLE CALCULATION	6
4.3. MEASUREMENT UNCERTAINTY.....	6
5. EQUIPMENT UNDER TEST	7
5.1. DESCRIPTION OF EUT	7
5.2. MAXIMUM OUTPUT POWER.....	7
5.3. DESCRIPTION OF AVAILABLE ANTENNAS	7
5.4. SOFTWARE AND FIRMWARE.....	8
5.5. WORST-CASE CONFIGURATION AND MODE.....	8
5.6. DESCRIPTION OF TEST SETUP.....	9
6. TEST AND MEASUREMENT EQUIPMENT	12
7. ANTENNA PORT TEST RESULTS	13
7.1. BASIC DATA RATE GFSK MODULATION.....	13
7.1.1. 20 dB BANDWIDTH.....	13
7.1.2. HOPPING FREQUENCY SEPARATION	17
7.1.3. NUMBER OF HOPPING CHANNELS.....	19
7.1.4. AVERAGE TIME OF OCCUPANCY	24
7.1.5. OUTPUT POWER	31
7.1.6. AVERAGE POWER.....	35
7.1.7. CONDUCTED SPURIOUS EMISSIONS.....	36
7.2. ENHANCED DATA RATE 8PSK MODULATION	45
7.2.1. 20 dB BANDWIDTH.....	45
7.2.2. HOPPING FREQUENCY SEPARATION	49
7.2.3. NUMBER OF HOPPING CHANNELS.....	51
7.2.4. AVERAGE TIME OF OCCUPANCY	56
7.2.5. OUTPUT POWER	63
7.2.6. AVERAGE POWER.....	67
7.2.7. CONDUCTED SPURIOUS EMISSIONS.....	68
8. RADIATED TEST RESULTS.....	77
8.1. LIMITS AND PROCEDURE.....	77
8.2. TRANSMITTER ABOVE 1 GHz.....	78
8.2.1. BASIC DATA RATE GFSK MODULATION.....	78
8.2.2. ENHANCED DATA RATE 8PSK MODULATION	87

1. ATTESTATION OF TEST RESULTS

COMPANY NAME: SAMSUNG ELECTRONICS CO., LTD
416, MAETAN 3-DONG, YEONGTONG-GU
SUWON CITY, GYEONGGI-DO 443-742, SOUTH KOREA

EUT DESCRIPTION: TABLET with GSM/GPRS/EDGE/WCDMA, 802.11bgn, BT3.0

MODEL: GT-P3100

SERIAL NUMBER: 03053 (CONDUCTED), 02000 & 3006 (RADIATED)

DATE TESTED: FEBRUARY 8-17, 2012

APPLICABLE STANDARDS	
STANDARD	TEST RESULTS
CFR 47 Part 15 Subpart C	PASS

Compliance Certification Services (UL CCS) tested the above equipment in accordance with the requirements set forth in the above standards. All indications of Pass/Fail in this report are opinions expressed by UL CCS based on interpretations and/or observations of test results. Measurement Uncertainties were not taken into account and are published for informational purposes only. The test results show that the equipment tested is capable of demonstrating compliance with the requirements as documented in this report.

Note: The results documented in this report apply only to the tested sample, under the conditions and modes of operation as described herein. This document may not be altered or revised in any way unless done so by UL CCS and all revisions are duly noted in the revisions section. Any alteration of this document not carried out by UL CCS will constitute fraud and shall nullify the document. This report must not be used by the client to claim product certification, approval, or endorsement by NVLAP, NIST, any agency of the Federal Government, or any agency of any government.

Approved & Released For UL CCS By:

Tested By:



FRANK IBRAHIM
EMC SUPERVISOR
UL CCS

STEVE AGUILAR
EMC TECHNICIAN
UL CCS

2. TEST METHODOLOGY

The tests documented in this report were performed in accordance with ANSI C63.10-2009, FCC CFR 47 Part 2, and FCC CFR 47 Part 15.

3. FACILITIES AND ACCREDITATION

The test sites and measurement facilities used to collect data are located at 47173 Benicia Street, Fremont, California, USA.

UL CCS is accredited by NVLAP, Laboratory Code 200065-0. The full scope of accreditation can be viewed at <http://www.ccsemc.com>.

4. CALIBRATION AND UNCERTAINTY

4.1. MEASURING INSTRUMENT CALIBRATION

The measuring equipment utilized to perform the tests documented in this report has been calibrated in accordance with the manufacturer's recommendations, and is traceable to recognized national standards.

4.2. SAMPLE CALCULATION

Where relevant, the following sample calculation is provided:

$$\begin{aligned} \text{Field Strength (dBuV/m)} &= \text{Measured Voltage (dBuV)} + \text{Antenna Factor (dB/m)} + \\ &\text{Cable Loss (dB)} - \text{Preamp Gain (dB)} \\ 36.5 \text{ dBuV} + 18.7 \text{ dB/m} + 0.6 \text{ dB} - 26.9 \text{ dB} &= 28.9 \text{ dBuV/m} \end{aligned}$$

4.3. MEASUREMENT UNCERTAINTY

Where relevant, the following measurement uncertainty levels have been estimated for tests performed on the apparatus:

PARAMETER	UNCERTAINTY
Conducted Disturbance, 0.15 to 30 MHz	3.52 dB
Radiated Disturbance, 30 to 1000 MHz	4.94 dB

Uncertainty figures are valid to a confidence level of 95%.

5. EQUIPMENT UNDER TEST

5.1. DESCRIPTION OF EUT

The EUT is a tablet with GSM/GPRS/EDGE/WCDMA, 802.11bgn, and Bluetooth 3.0.

The radio module is manufactured by Broadcom Corporations.

5.2. MAXIMUM OUTPUT POWER

The transmitter has a maximum peak conducted output power as follows:

2400 to 2483.5 MHz Authorized Band

Frequency Range (MHz)	Mode	Output Power (dBm)	Output Power (mW)
2400-2480	Basic GFSK	12.19	16.56
	Enhanced 8PSK	12.15	16.41

5.3. DESCRIPTION OF AVAILABLE ANTENNAS

The radio utilizes an 802.11 b/g/n and a Bluetooth antenna, with a maximum gain as stated in the table below:

No.	Contents	Standards			Unit	Condition	Remarks
		Min.	Avg.	Max.			
1	Gain of BT/WIFI	-6.4	-	-1.4	dBi	Based on Max. Gain in H-Plane.	
2	VSWR of BT/WIFI	1.2	1.7	2.2	-	2213 MHz	Jig Data
		1.2	1.7	2.2	-	2233 MHz	

5.4. SOFTWARE AND FIRMWARE

Bluetooth firmware - BCM4330B1_002.001.003.0634.0678.hcd
Wi-Fi Firmware Rev 5.90.125.1191

EUT driver software version: P3100.001

5.5. WORST-CASE CONFIGURATION AND MODE

Radiated emission and power line conducted emission were performed with the EUT set to transmit at the channel with highest output power as worst-case scenario.

For the fundamental investigation, since the EUT is a portable device that has three orientations; therefore X, Y and Z orientations have been investigated, also with AC/DC adapter, and earphone, and the worst case was found to be at Y orientation with headset alone.

5.6. DESCRIPTION OF TEST SETUP

SUPPORT EQUIPMENT

PERIPHERAL SUPPORT EQUIPMENT LIST				
Description	Manufacturer	Model	Serial Number	FCC ID
AC Adapter	Samsung	ETA-P11X	3046	N/A
Headset	Samsung	EHS64AVFWE	3040	N/A

I/O CABLES (CONDUCTED SETUP)

I/O CABLE LIST						
Cable No.	Port	# of Identical Ports	Connector Type	Cable Type	Cable Length	Remarks
1	AC	2	US 115V	Un-shielded	2.0 m	NA
2	DC	1	USB	shielded	1.0m	NA
3	RF	1	SMA	Shielded	0.6 m	NA

I/O CABLES (RADIATED SETUP)

I/O CABLE LIST						
Cable No.	Port	# of Identical Ports	Connector Type	Cable Type	Cable Length	Remarks
1	DC	1	DC	Un-shielded	1.0m	NA
2	Audio	1	Earphone	Un-shielded	1.2m	Volume Control on Cable

TEST SETUP

The EUT is connected to Bluetooth tester via a directional coupler during the tests.

SETUP DIAGRAM FOR TESTS (CONDUCTED TEST SETUP)

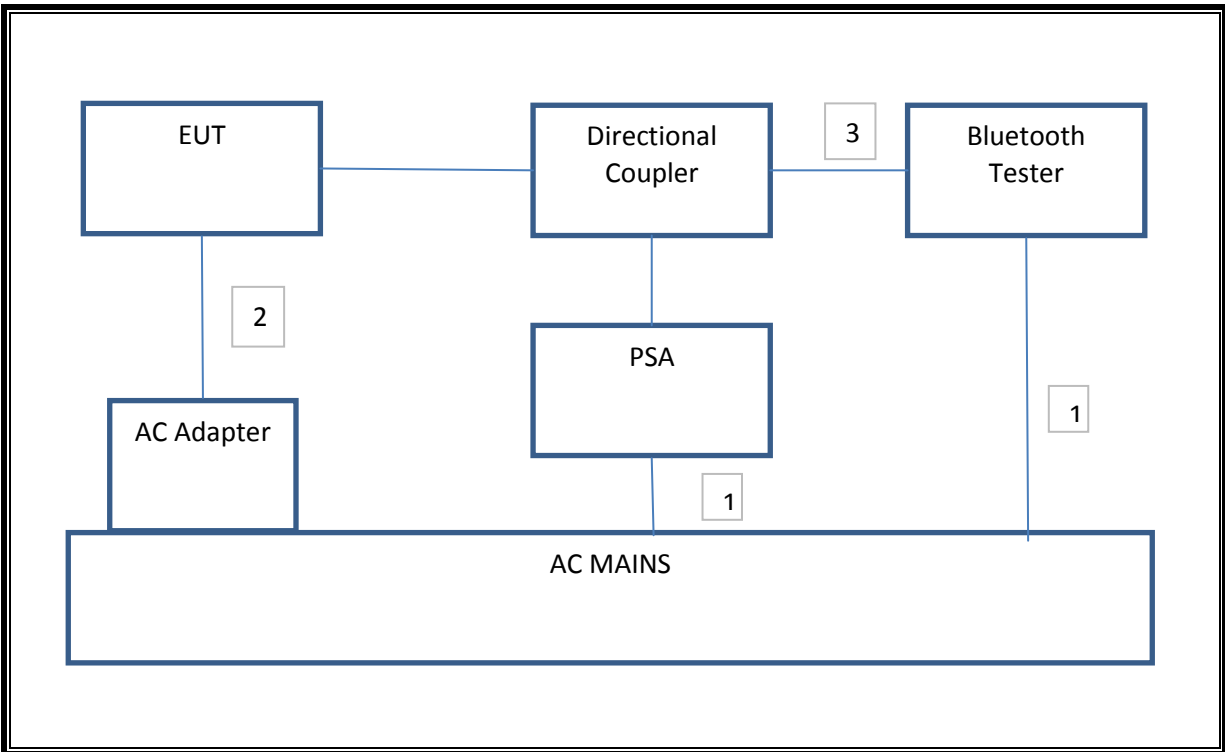

SETUP DIAGRAM FOR TESTS (RADIATED TEST SETUP)

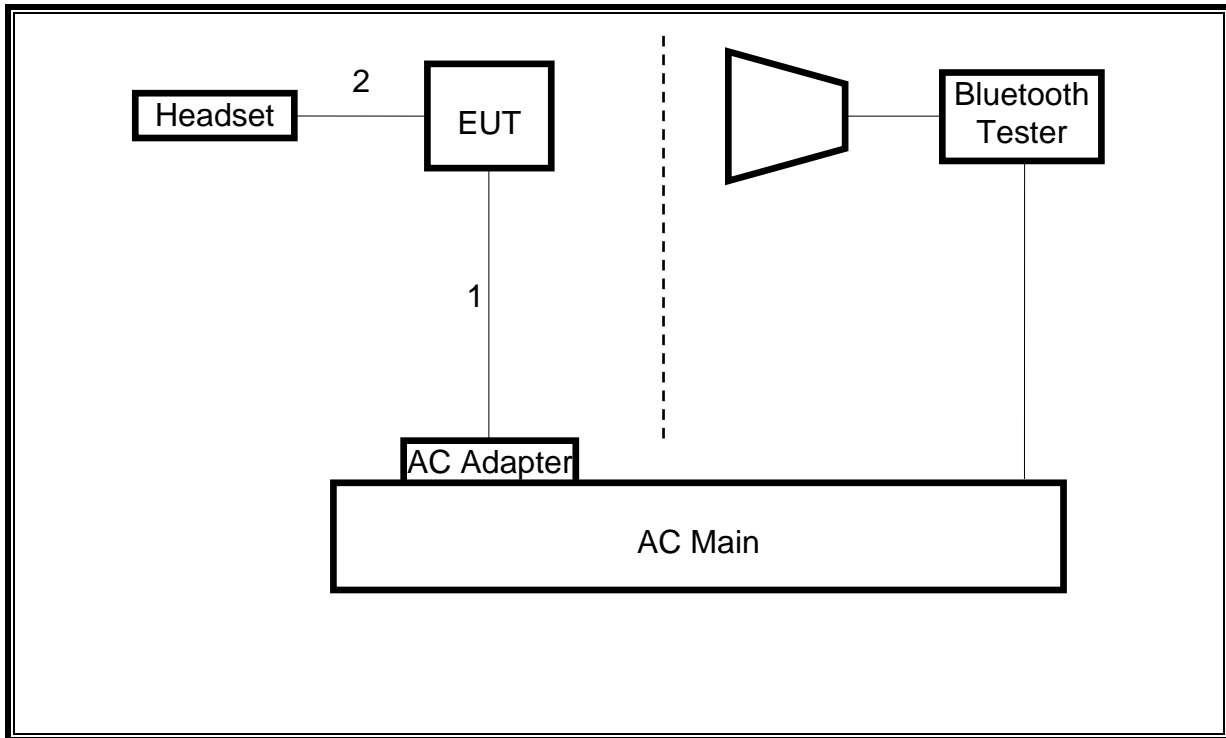

6. TEST AND MEASUREMENT EQUIPMENT

The following test and measurement equipment was utilized for the tests documented in this report:

TEST EQUIPMENT LIST					
Description	Manufacturer	Model	Asset	Cal Date	Cal Due
Spectrum Analyzer, 26.5 GHz	Agilent / HP	E4440A	C01179	01/28/11	04/28/12
EMI Test Receiver, 9 kHz-7 GHz	R & S	ESCI 7	1000741	07/06/11	07/06/12
Bluetooth Tester	R & S	N/A	N/A	04/27/11	04/27/12
Antenna, Bilog, 2 GHz	Sunol Sciences	JB1	C01011	07/16/11	07/16/12
Antenna, Horn, 18 GHz	EMCO	3115	C00872	06/29/11	06/29/12
Preamplifier, 1300 MHz	Agilent / HP	8447D	C00558	11/11/11	11/11/12
Preamplifier, 26.5 GHz	Agilent / HP	8449B	C00749	07/18/11	07/18/12
Directional Coupler	RF-:ambda	N/A	11101300751	CNR	CNR
LISN, 30 MHz	FCC	LISN-50/250-25-2	N02625	12/13/11	12/13/12

7. ANTENNA PORT TEST RESULTS

7.1. BASIC DATA RATE GFSK MODULATION

7.1.1. 20 dB BANDWIDTH

LIMIT

None; for reporting purposes only.

TEST PROCEDURE

The transmitter output is connected to a spectrum analyzer. The RBW is set to $\geq 1\%$ of the 20 dB bandwidth. The VBW is set to \geq RBW. The sweep time is coupled.

RESULTS

Channel	Frequency (MHz)	20 dB Bandwidth (MHz)
Low	2402	1.041
Middle	2441	1.041
High	2480	1.041

20 dB BANDWIDTH

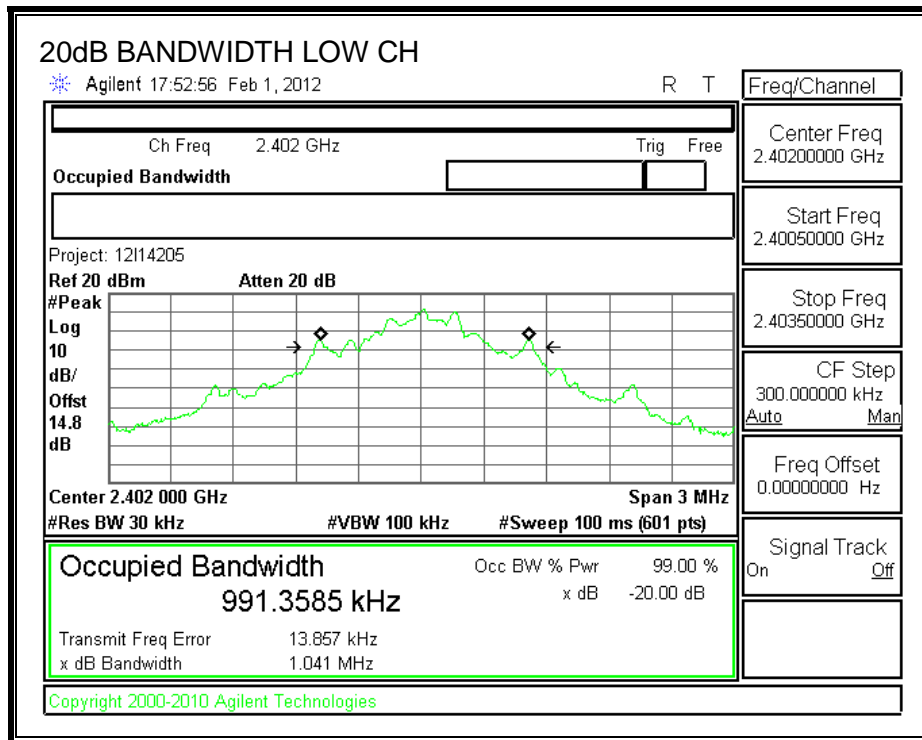

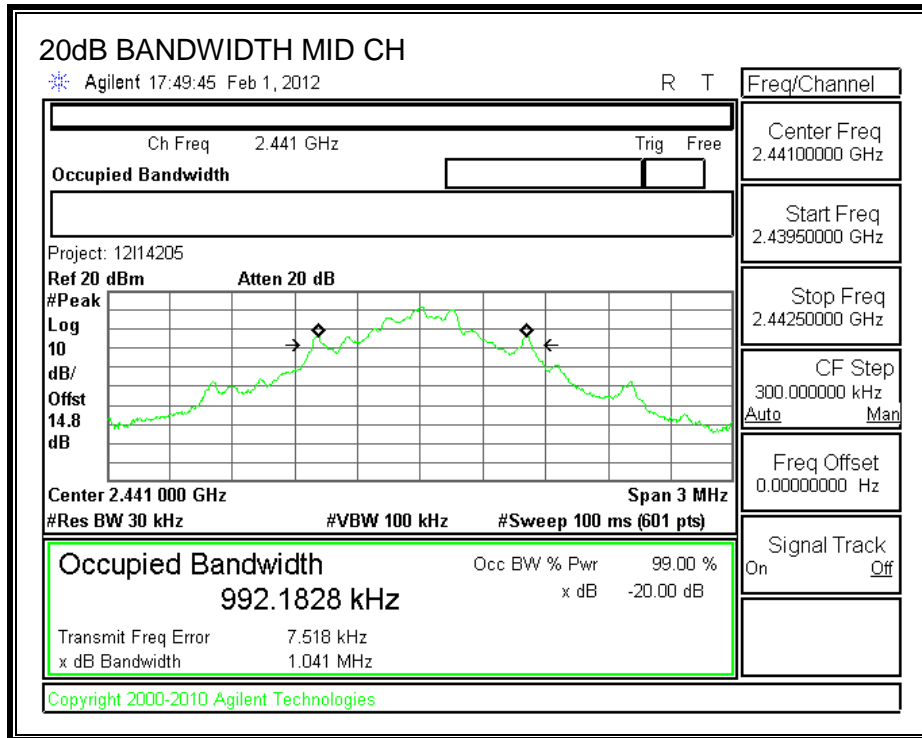

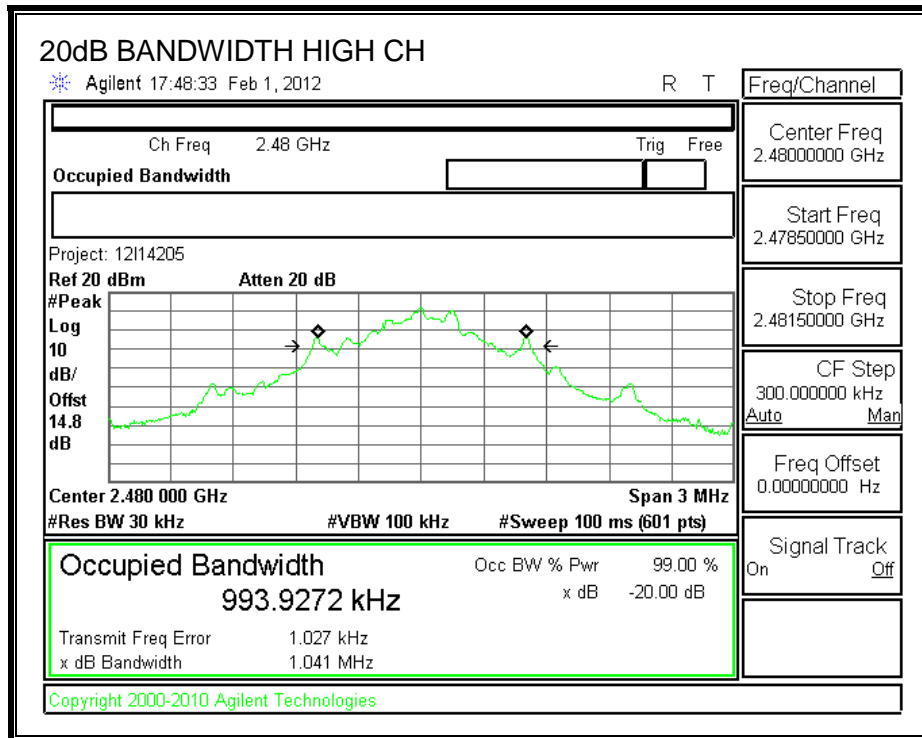

7.1.2. HOPPING FREQUENCY SEPARATION

LIMIT

FCC §15.247 (a) (1)

Frequency hopping systems shall have hopping channel carrier frequencies separated by a minimum of 25 kHz or the 20 dB bandwidth of the hopping channel, whichever is greater.

Alternatively, frequency hopping systems operating in the 2400-2483.5 MHz band may have hopping channel carrier frequencies that are separated by 25 kHz or two-thirds of the 20 dB bandwidth of the hopping channel, whichever is greater, provided the systems operate with an output power no greater than 125 mW.

TEST PROCEDURE

The transmitter output is connected to a spectrum analyzer. The RBW is set to 100 kHz and the VBW is set to 100 kHz. The sweep time is coupled.

RESULTS

HOPPING FREQUENCY SEPARATION

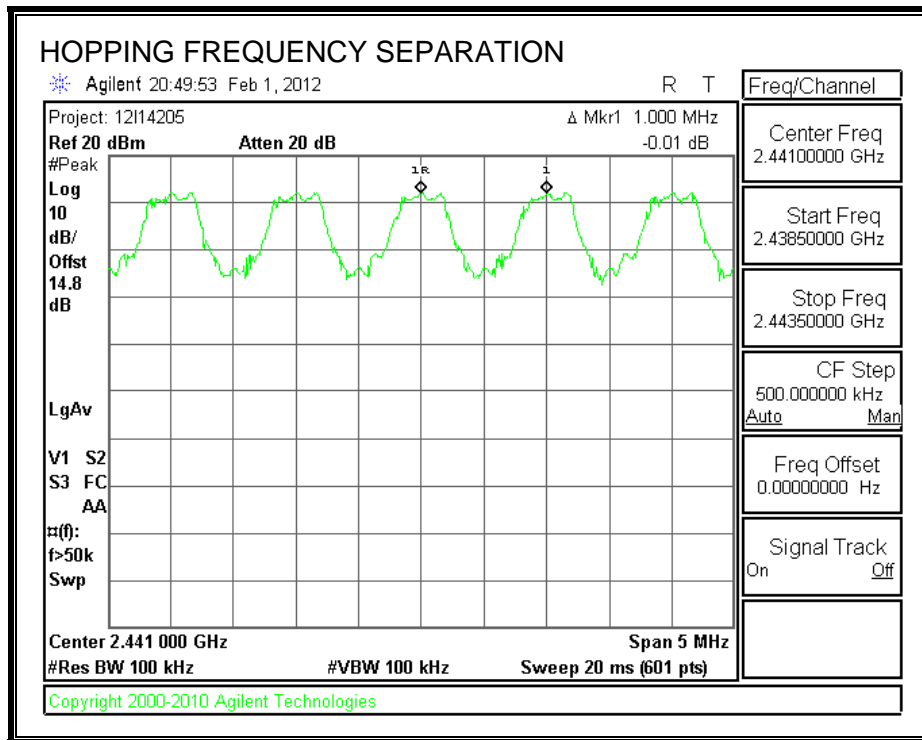

7.1.3. NUMBER OF HOPPING CHANNELS

LIMIT

FCC §15.247 (a) (1) (iii)

Frequency hopping systems in the 2400 – 2483.5 MHz band shall use at least 15 non-overlapping channels.

TEST PROCEDURE

The transmitter output is connected to a spectrum analyzer. The span is set to cover the entire authorized band, in either a single sweep or in multiple contiguous sweeps. The RBW is set to a maximum of 1 % of the span. The analyzer is set to Max Hold.

RESULTS

79 Channels observed.

NUMBER OF HOPPING CHANNELS

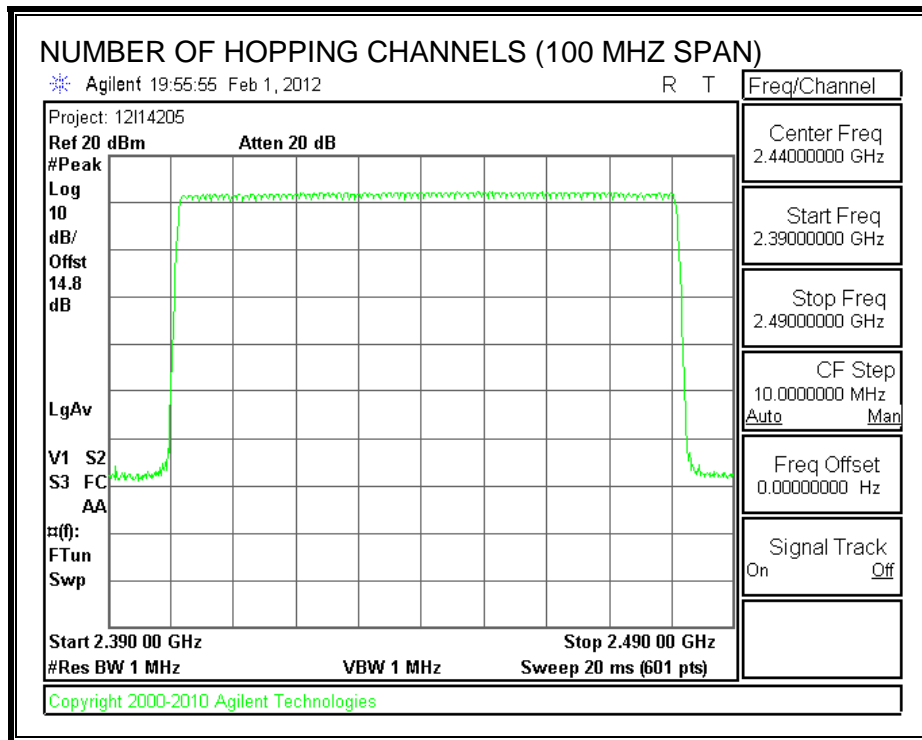

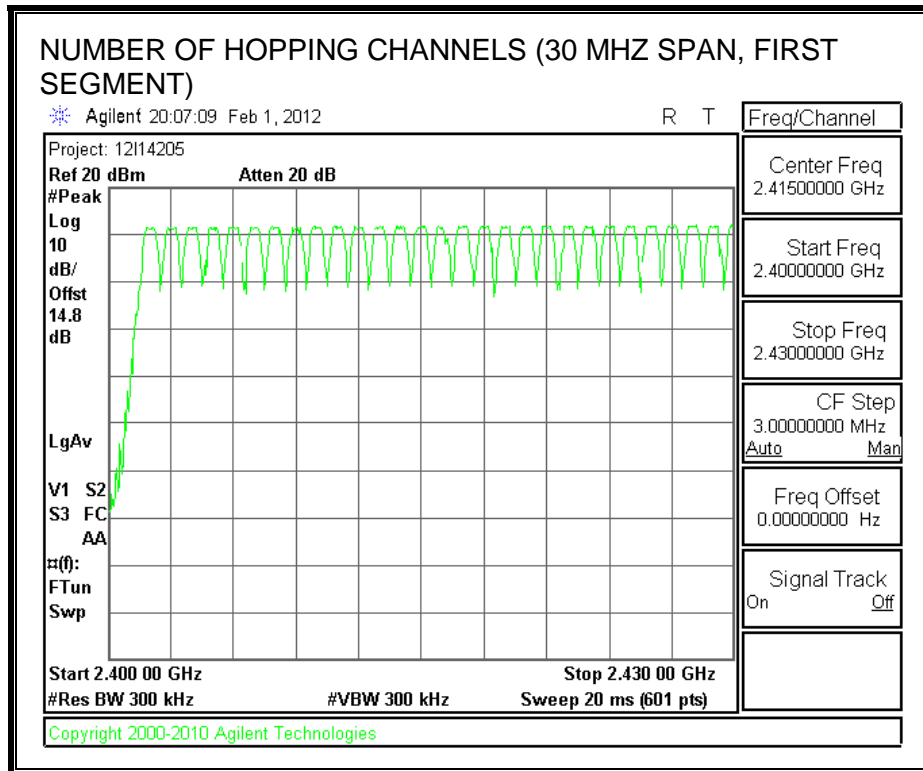

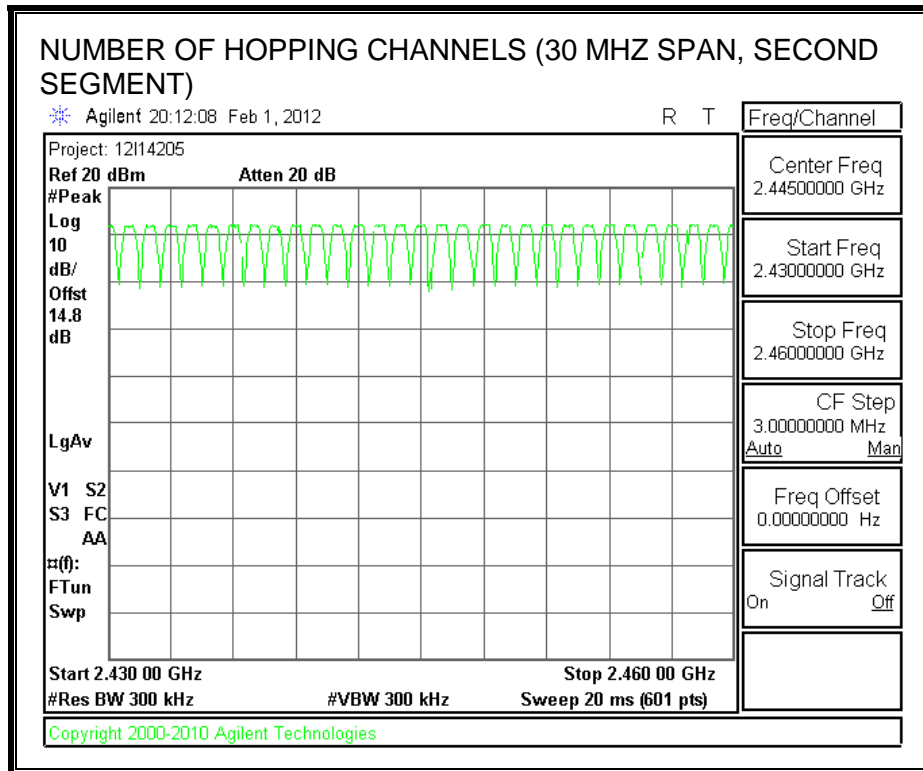

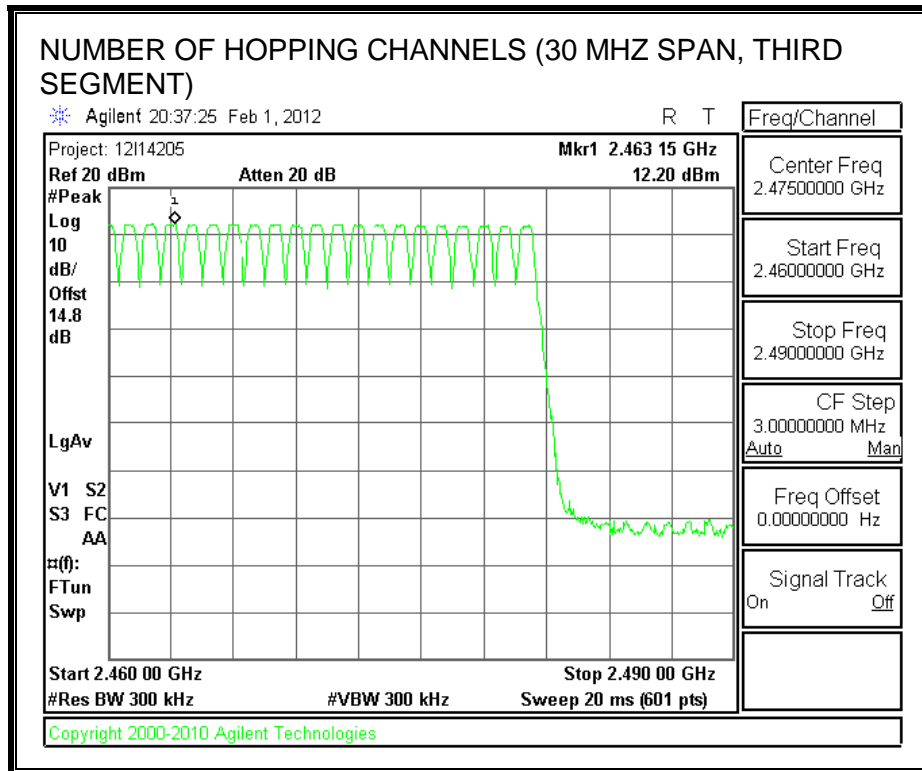

7.1.4. AVERAGE TIME OF OCCUPANCY

LIMIT

FCC §15.247 (a) (1) (iii)

The average time of occupancy on any channel shall not be greater than 0.4 seconds within a period of 0.4 seconds multiplied by the number of hopping channels employed.

TEST PROCEDURE

The transmitter output is connected to a spectrum analyzer. The span is set to 0 Hz, centered on a single, selected hopping channel. The width of a single pulse is measured in a fast scan. The number of pulses is measured in a 3.16 second scan, to enable resolution of each occurrence.

The average time of occupancy in the specified 31.6 second period (79 channels * 0.4 s) is equal to $10 * (\# \text{ of pulses in } 3.16 \text{ s}) * \text{ pulse width}$.

RESULTS

GFSK Mode

DH Packet	Pulse Width (msec)	Number of Pulses in 3.16 seconds	Average Time of (sec)	Limit (sec)	Margin (sec)
DH1	0.392	32	0.125	0.4	-0.275
DH3	1.640	17	0.279	0.4	-0.121
DH5	2.900	11	0.319	0.4	-0.081

DH1

PULSE WIDTH

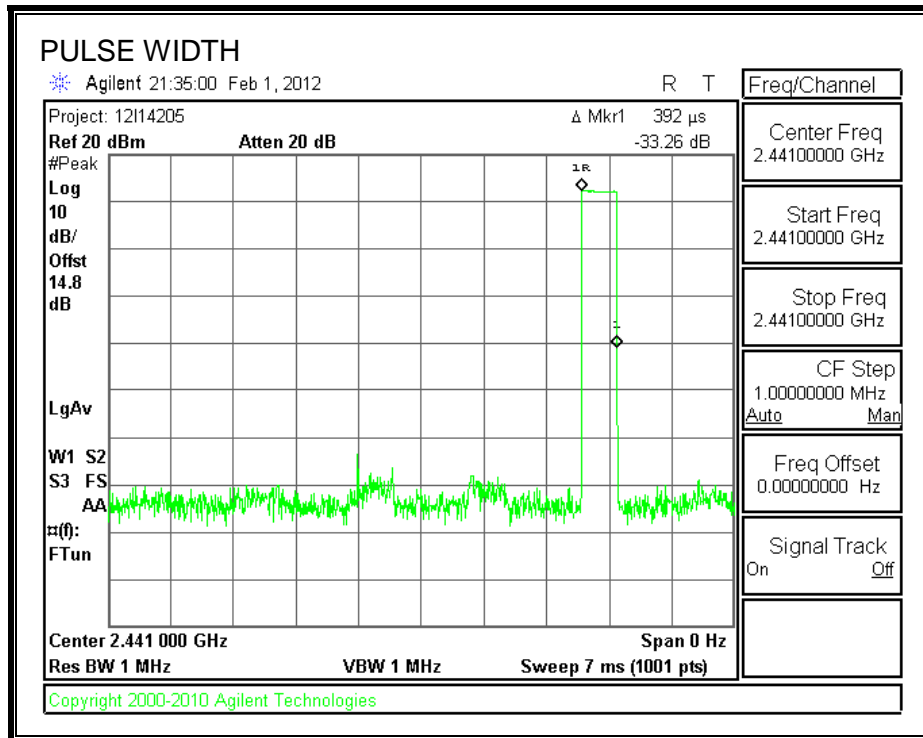

NUMBER OF PULSES IN 3.16 SECOND OBSERVATION PERIOD

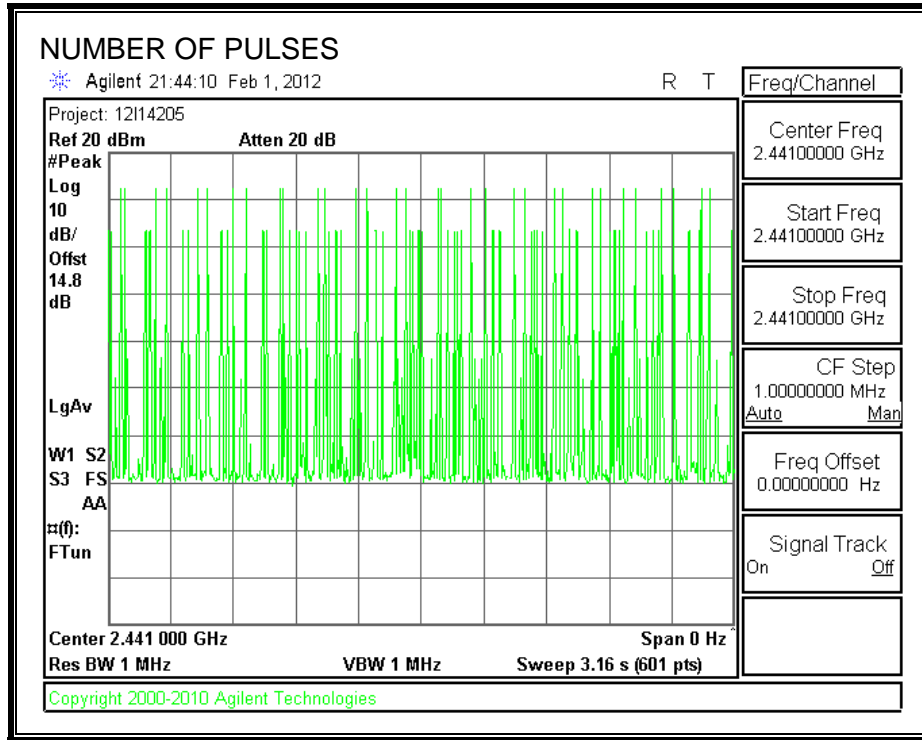

DH3

PULSE WIDTH

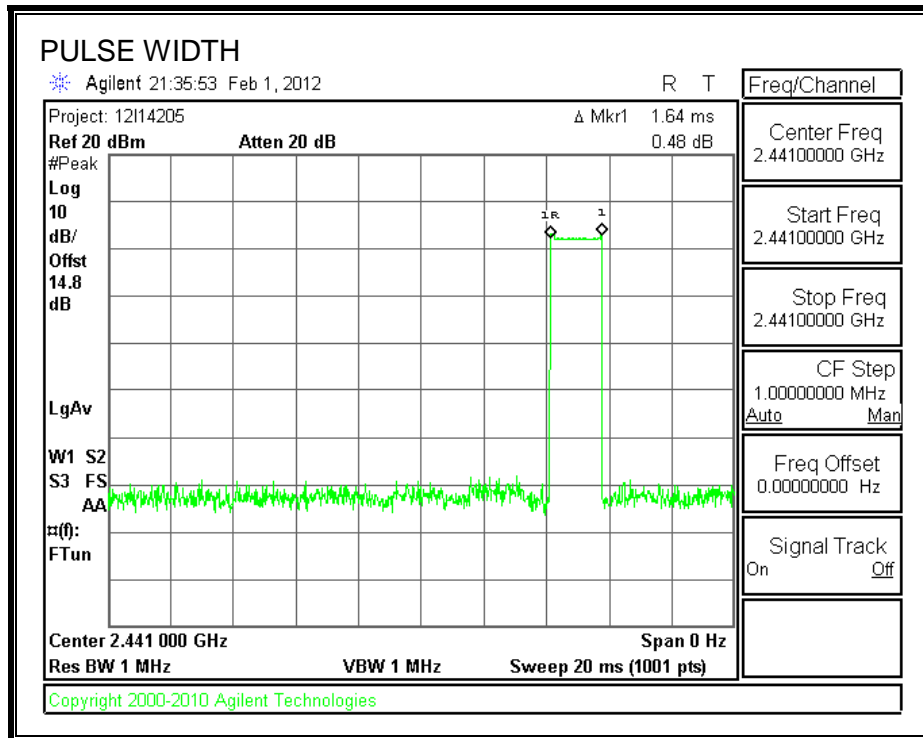

NUMBER OF PULSES IN 3.16 SECOND OBSERVATION PERIOD

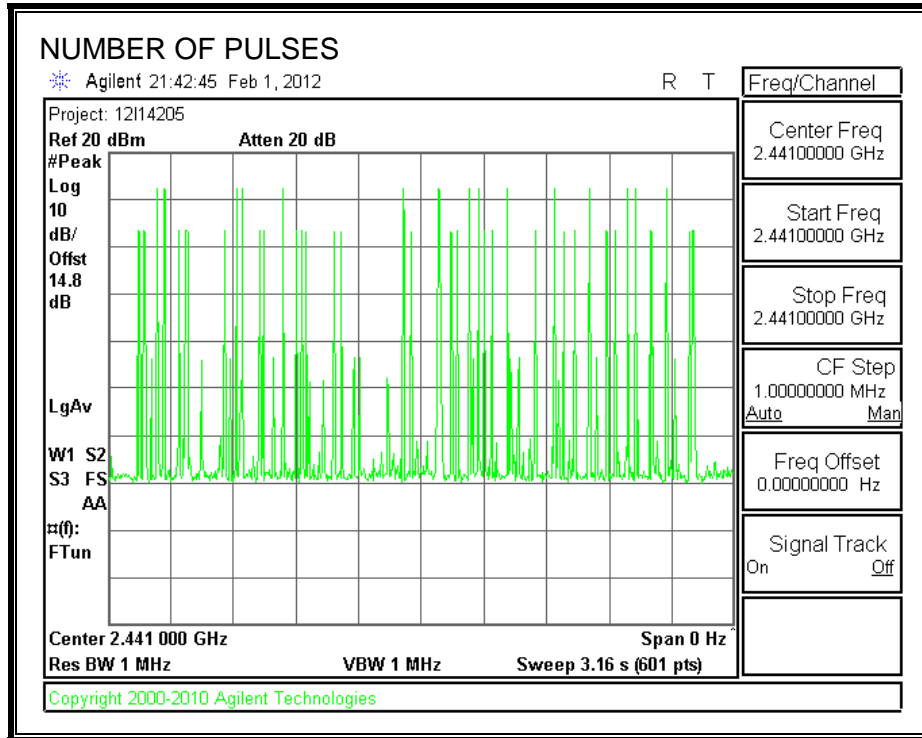

DH5

PULSE WIDTH

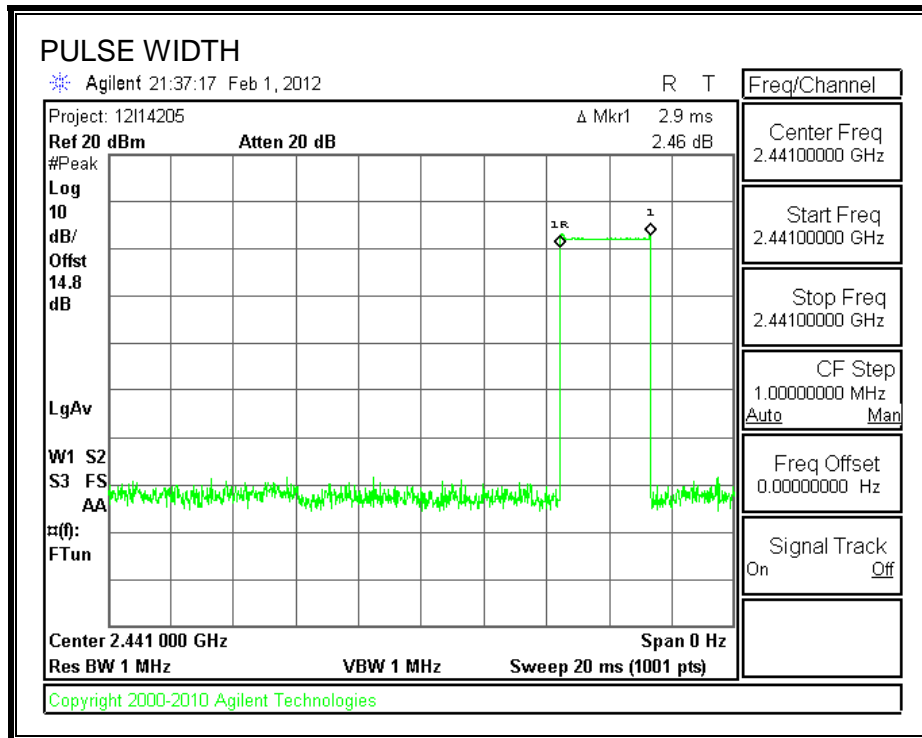

NUMBER OF PULSES IN 3.16 SECOND OBSERVATION PERIOD

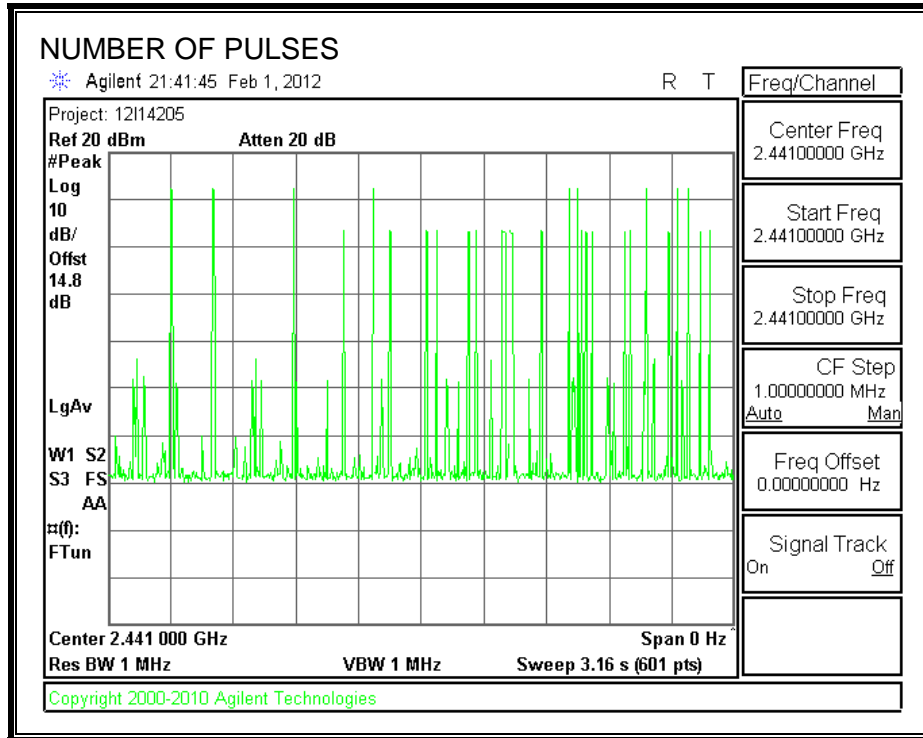

7.1.5. OUTPUT POWER

LIMIT

§15.247 (b) (1)

The maximum antenna gain is less than 6 dBi, therefore the limit is 30 dBm.

TEST PROCEDURE

The transmitter output is connected to a spectrum analyzer the analyzer bandwidth is set to a value greater than the 20 dB bandwidth of the EUT.

RESULTS

Channel	Frequency (MHz)	Output Power (dBm)	Limit (dBm)	Margin (dB)
Low	2402	11.88	30	-18.12
Middle	2441	12.19	30	-17.81
High	2480	12.10	30	-17.90

OUTPUT POWER

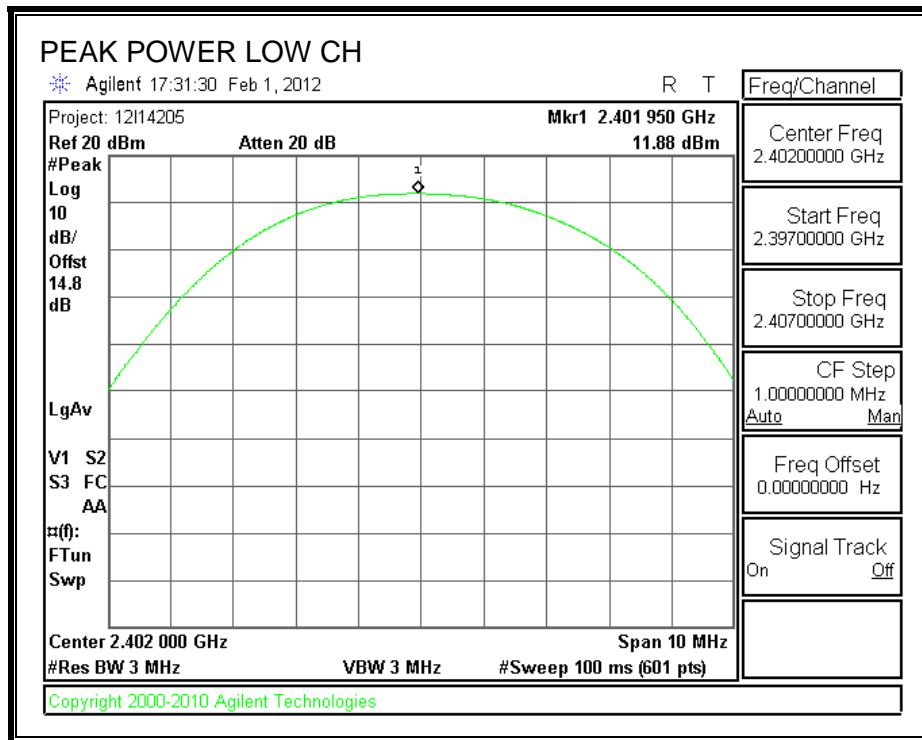

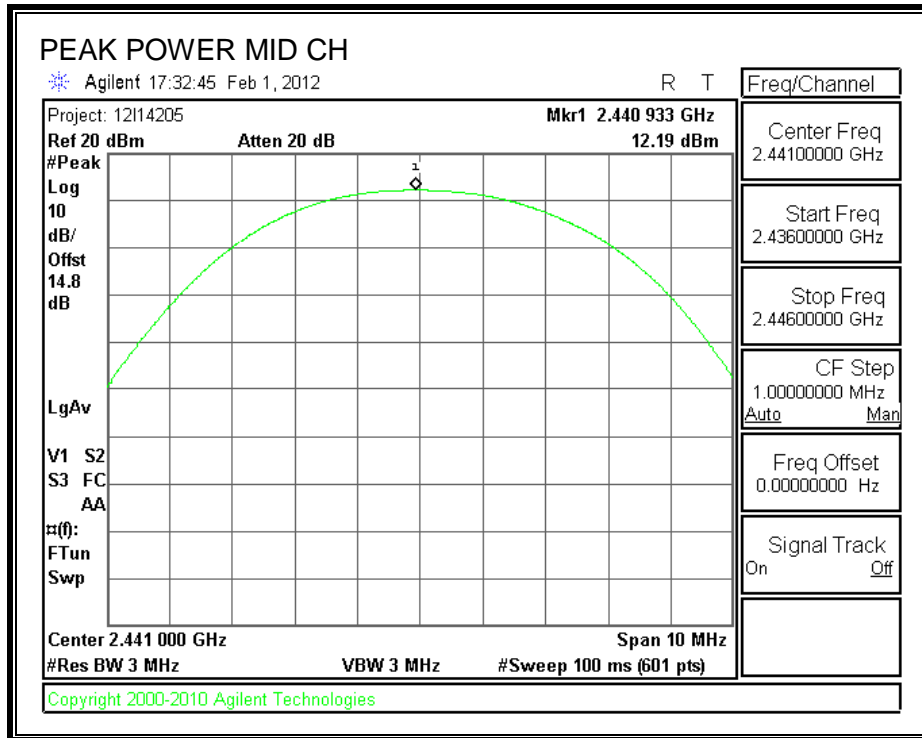

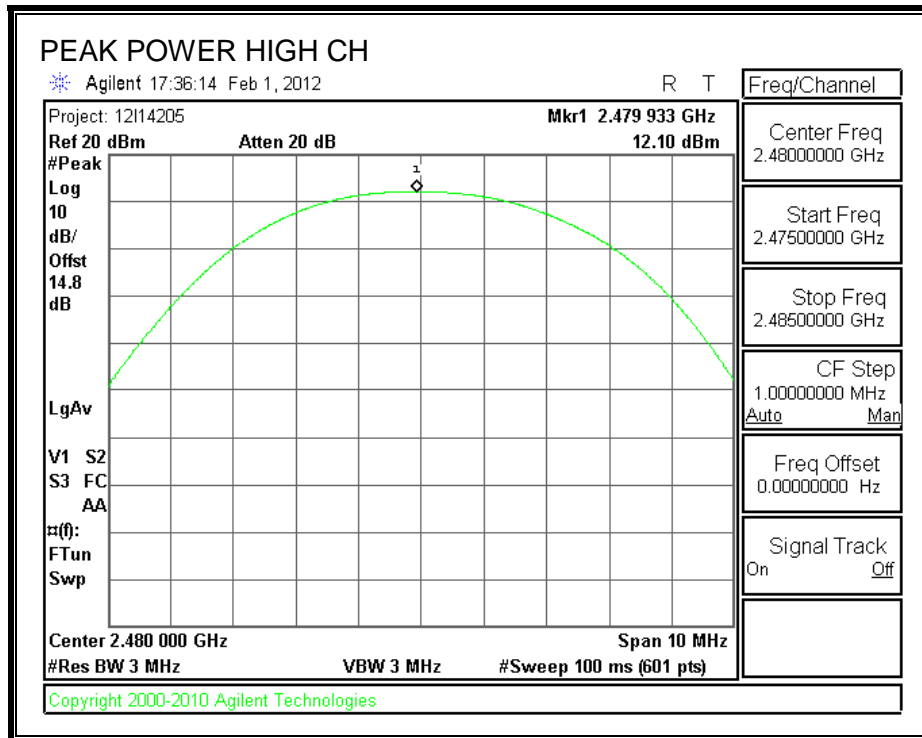

7.1.6. AVERAGE POWER

LIMIT

None; for reporting purposes only.

TEST PROCEDURE

The transmitter output is connected to a power meter.

RESULTS

The cable assembly insertion loss of 11.88 dB (including 10 dB pad and 1.88 dB cable) was entered as an offset in the power meter to allow for direct reading of power.

Channel	Frequency (MHz)	Average Power (dBm)
Low	2402	11.10
Middle	2441	11.30
High	2480	11.10

7.1.7. CONDUCTED SPURIOUS EMISSIONS

LIMITS

FCC §15.247 (d)

IC RSS-210 A8.5

Limit = -20 dBc

TEST PROCEDURE

The transmitter output is connected to a spectrum analyzer. The resolution bandwidth is set to 100 kHz. The video bandwidth is set to 300 kHz.

The spectrum from 30 MHz to 26 GHz is investigated with the transmitter set to the lowest, middle, and highest channels.

The bandedges at 2.4 and 2.4835 GHz are investigated with the transmitter set to the normal hopping mode.

RESULTS

SPURIOUS EMISSIONS, LOW CHANNEL

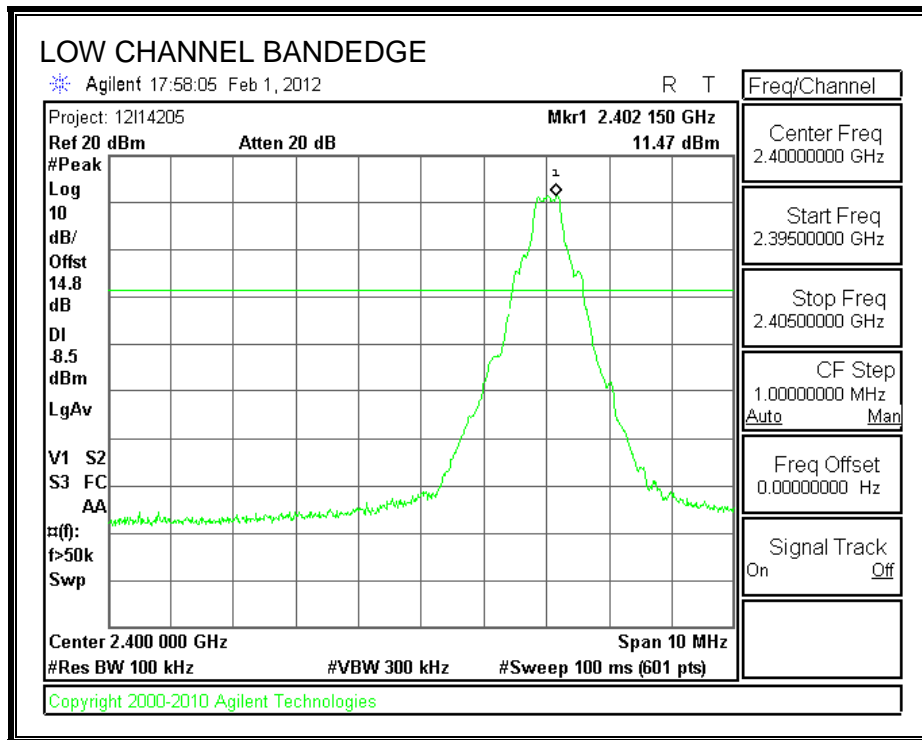

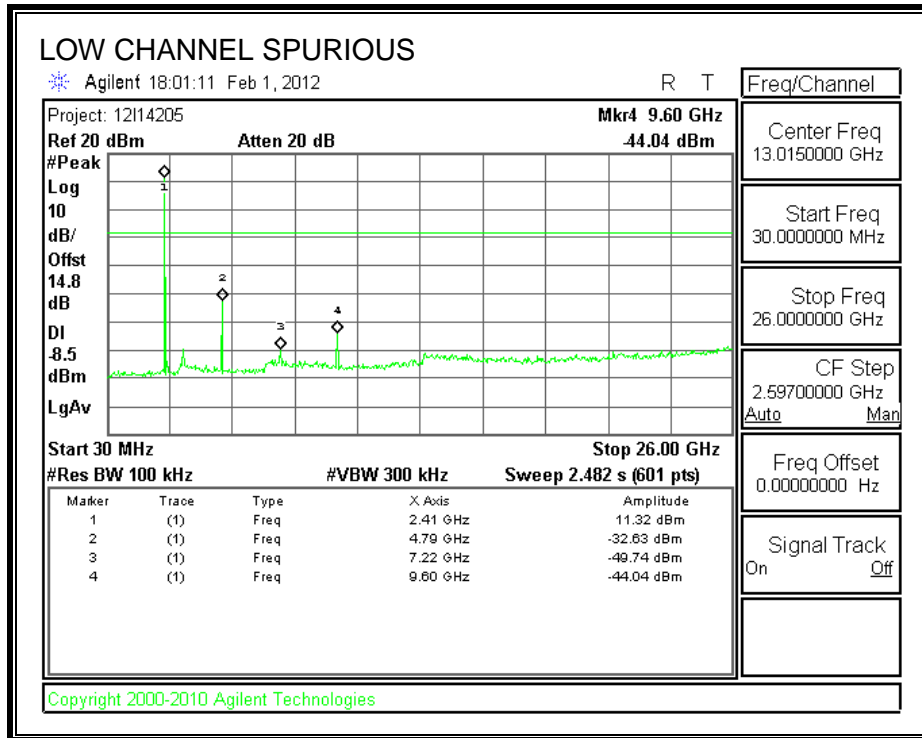

SPURIOUS EMISSIONS, MID CHANNEL

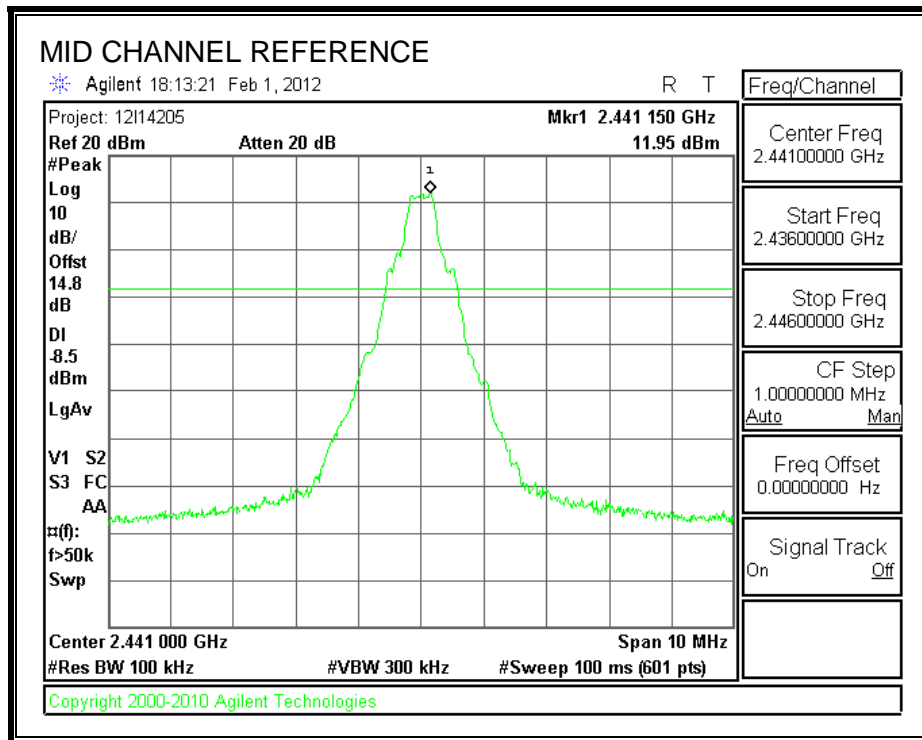

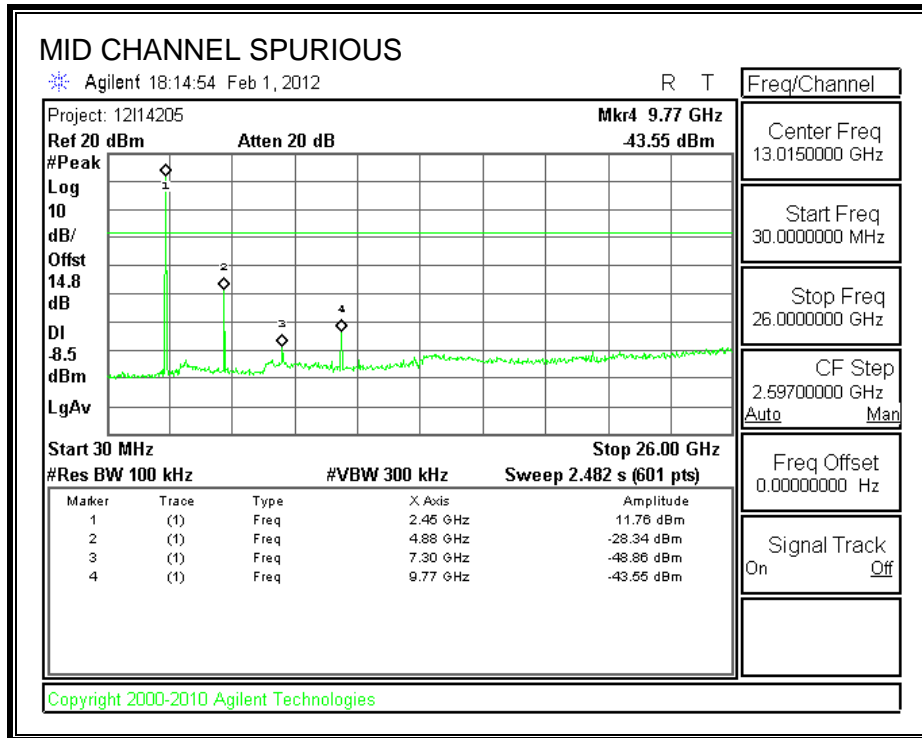

SPURIOUS EMISSIONS, HIGH CHANNEL

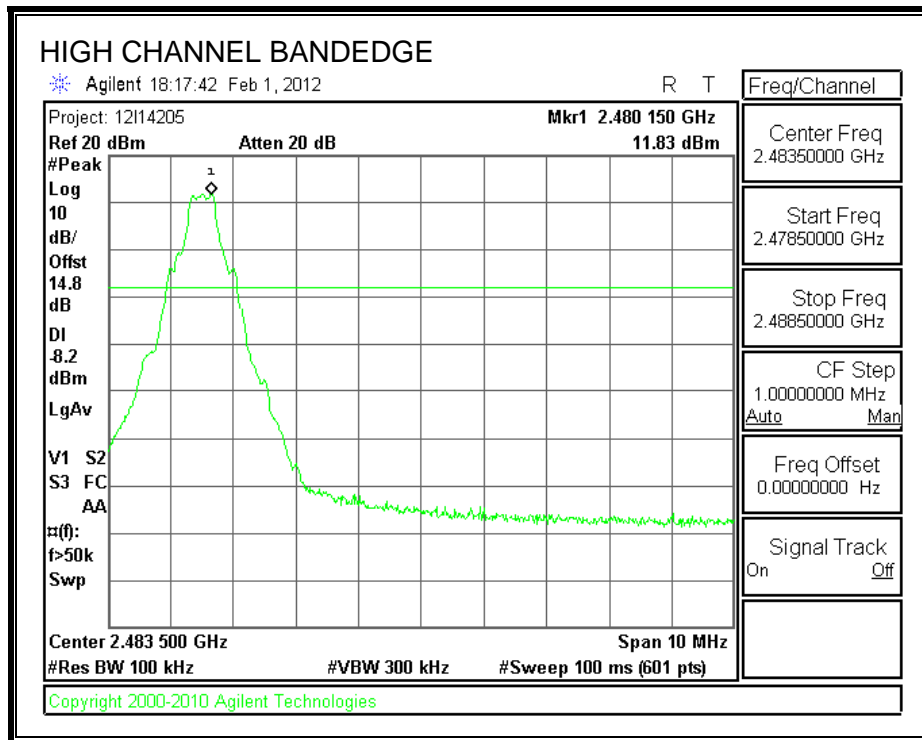

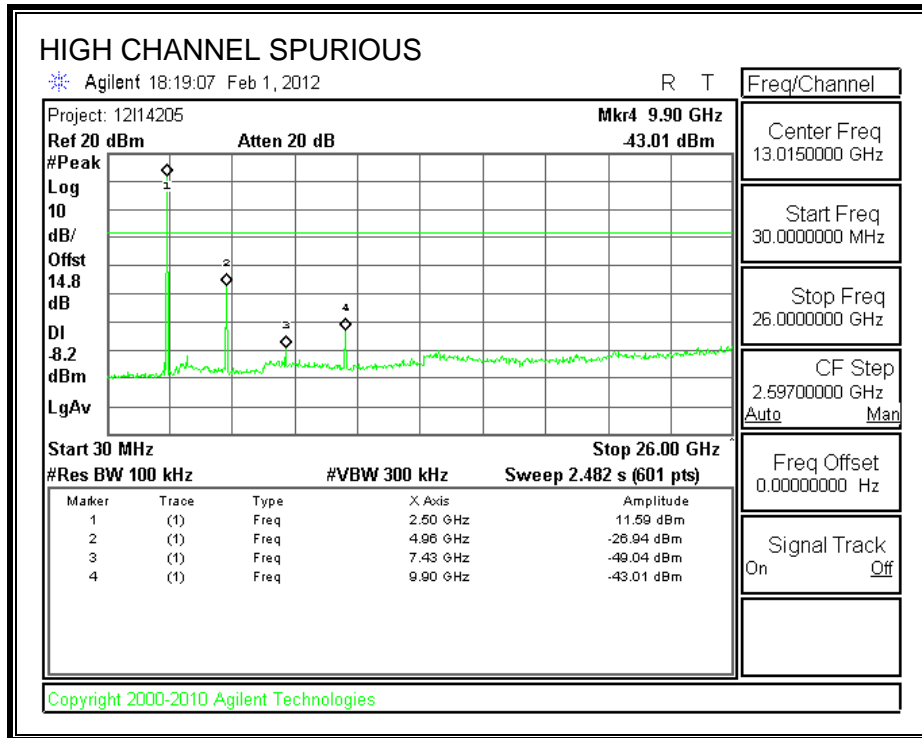

SPURIOUS BANDEDGE EMISSIONS WITH HOPPING ON

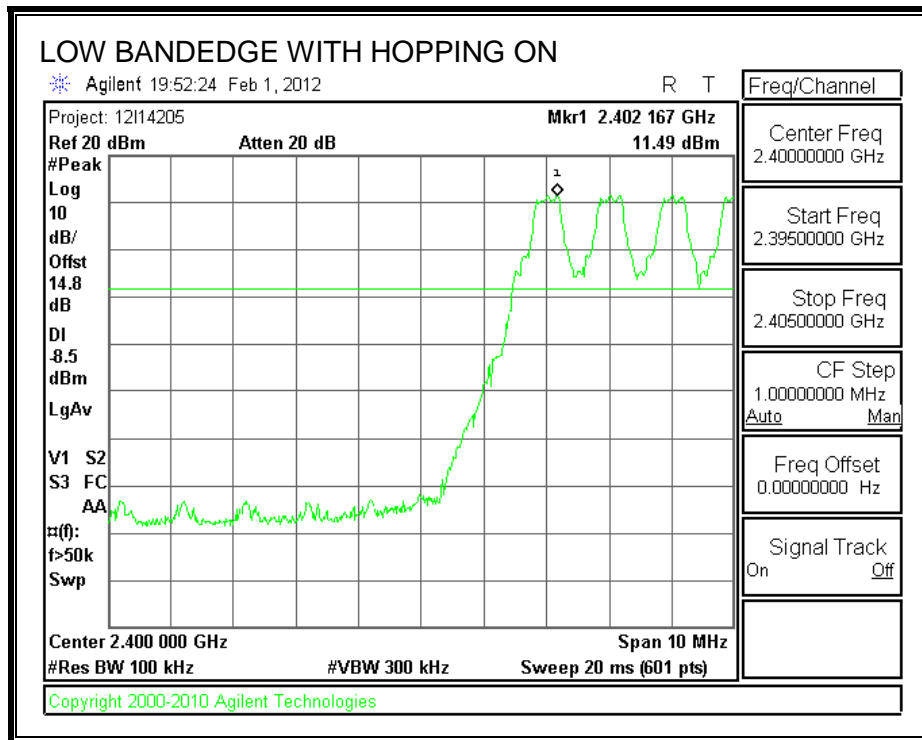

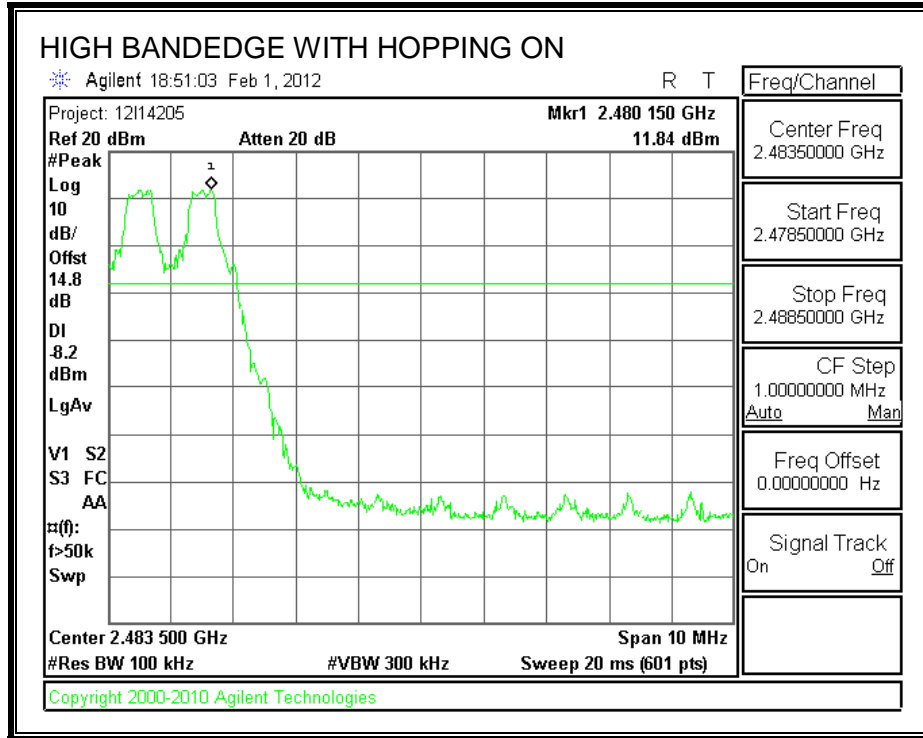

7.2. ENHANCED DATA RATE 8PSK MODULATION

7.2.1. 20 dB BANDWIDTH

LIMIT

None; for reporting purposes only.

TEST PROCEDURE

The transmitter output is connected to a spectrum analyzer. The RBW is set to $\geq 1\%$ of the 20 dB bandwidth. The VBW is set to \geq RBW. The sweep time is coupled.

RESULTS

Channel	Frequency (MHz)	20 dB Bandwidth (MHz)
Low	2402	1.192
Middle	2441	1.190
High	2480	1.189

20 dB BANDWIDTH

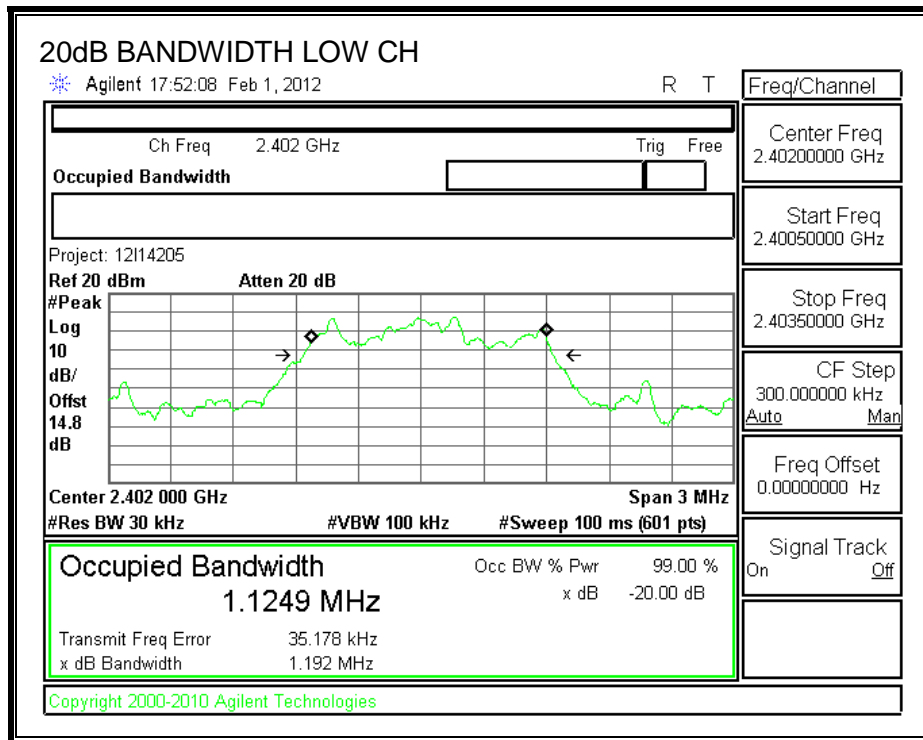

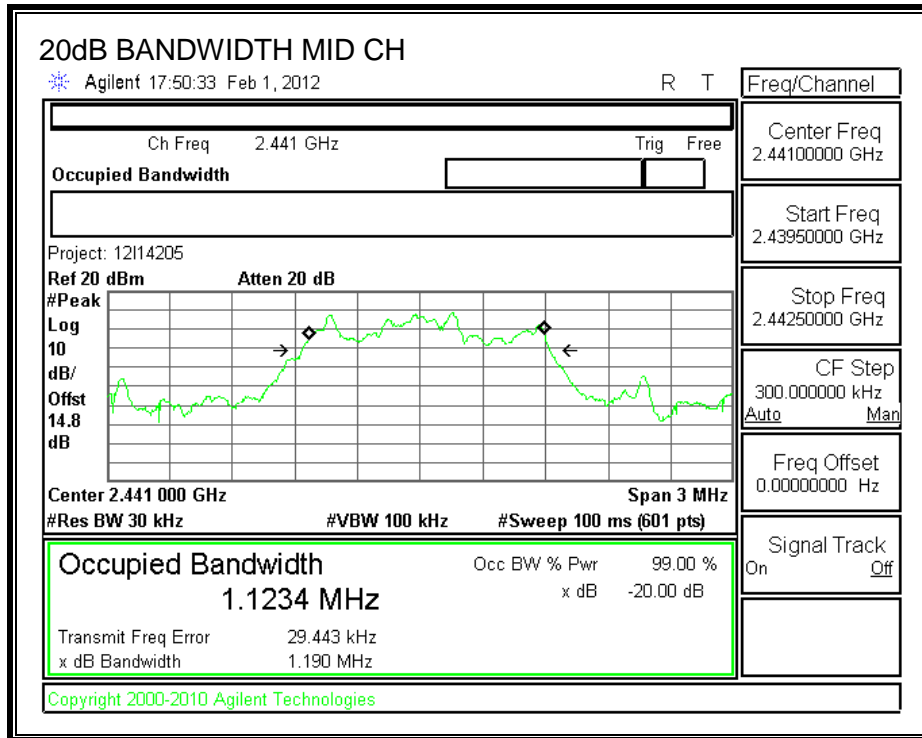

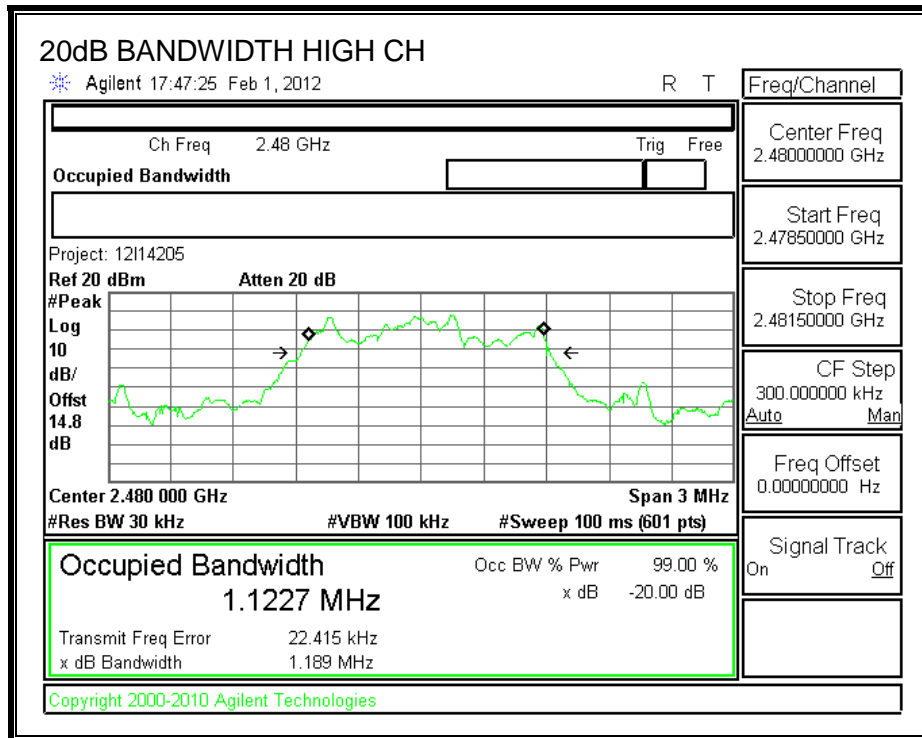

7.2.2. HOPPING FREQUENCY SEPARATION

LIMIT

FCC §15.247 (a) (1)

Frequency hopping systems shall have hopping channel carrier frequencies separated by a minimum of 25 kHz or the 20 dB bandwidth of the hopping channel, whichever is greater.

Alternatively, frequency hopping systems operating in the 2400-2483.5 MHz band may have hopping channel carrier frequencies that are separated by 25 kHz or two-thirds of the 20 dB bandwidth of the hopping channel, whichever is greater, provided the systems operate with an output power no greater than 125 mW.

TEST PROCEDURE

The transmitter output is connected to a spectrum analyzer. The RBW is set to 100 kHz and the VBW is set to 100 kHz. The sweep time is coupled.

RESULTS

HOPPING FREQUENCY SEPARATION

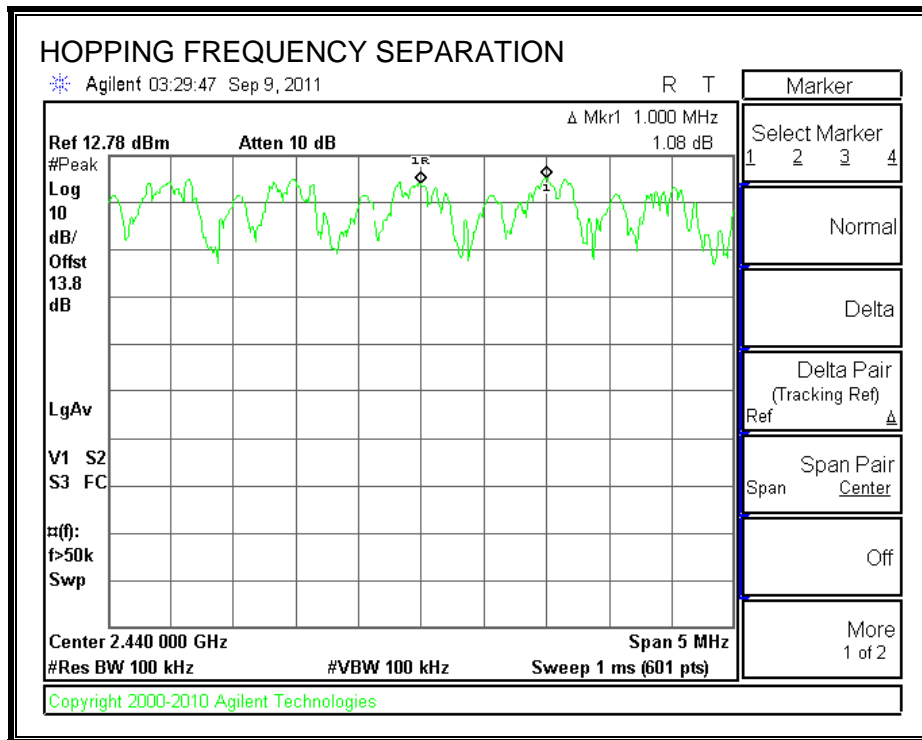

7.2.3. NUMBER OF HOPPING CHANNELS

LIMIT

FCC §15.247 (a) (1) (iii)

Frequency hopping systems in the 2400 – 2483.5 MHz band shall use at least 15 non-overlapping channels.

TEST PROCEDURE

The transmitter output is connected to a spectrum analyzer. The span is set to cover the entire authorized band, in either a single sweep or in multiple contiguous sweeps. The RBW is set to a maximum of 1 % of the span. The analyzer is set to Max Hold.

RESULTS

79 Channels observed.

NUMBER OF HOPPING CHANNELS

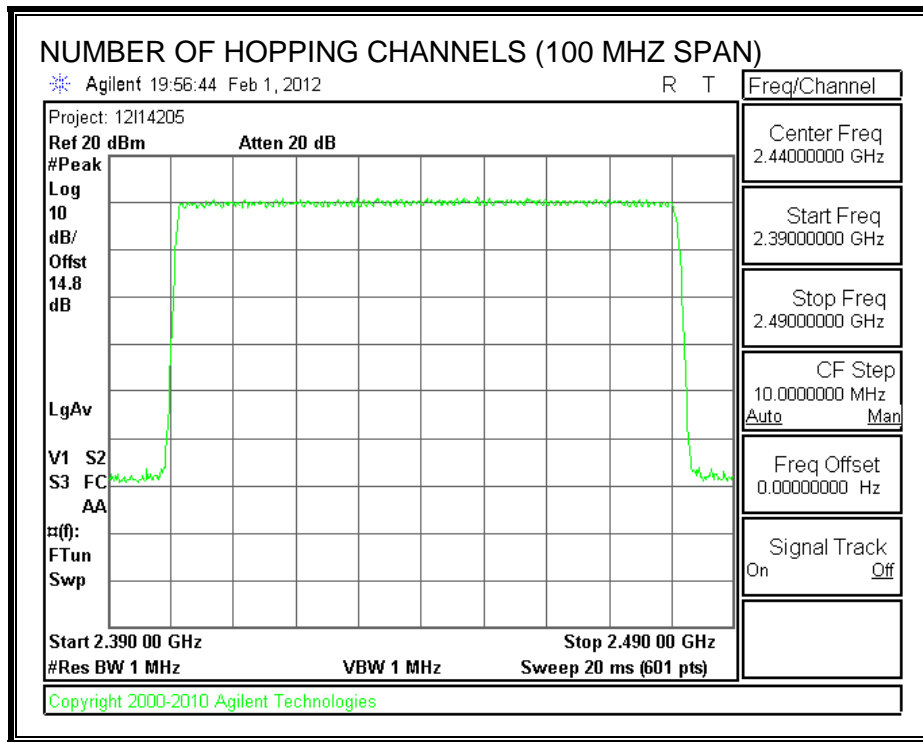

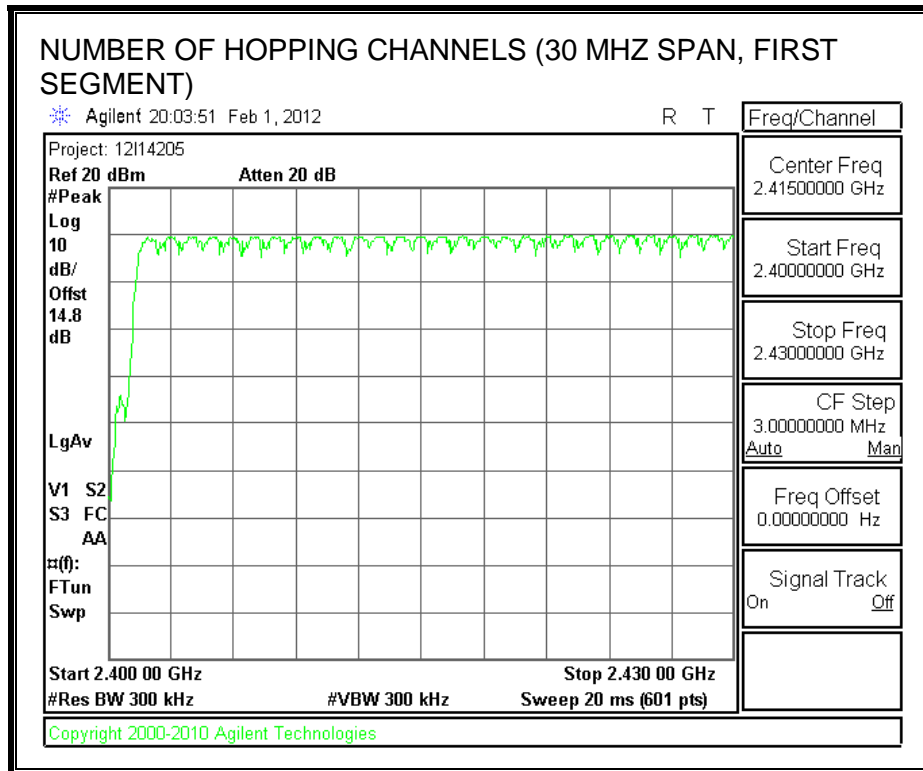

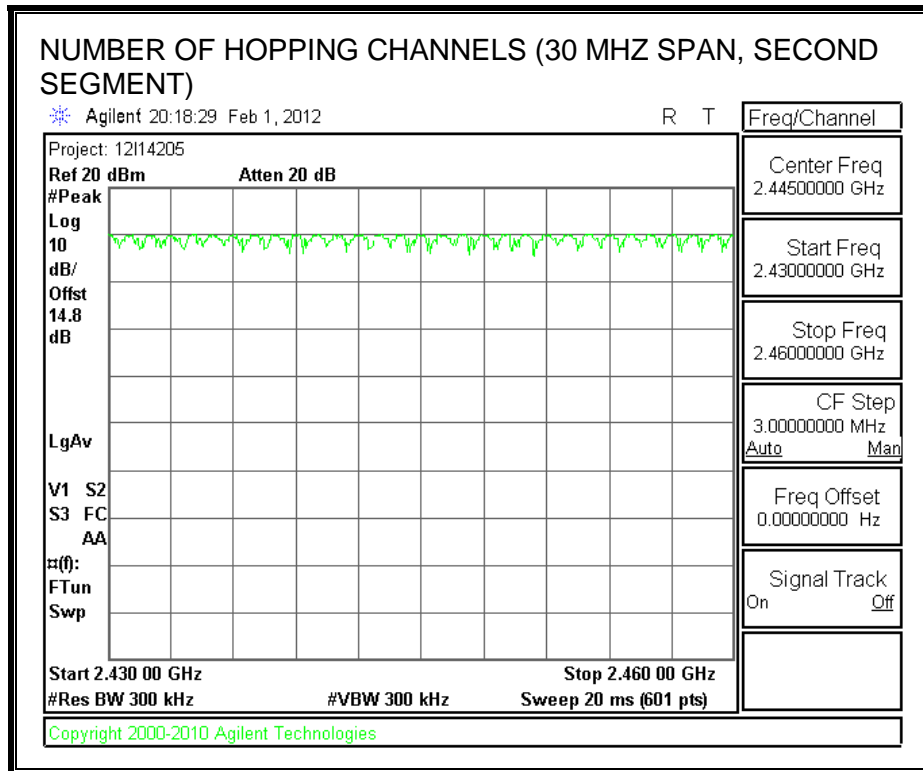

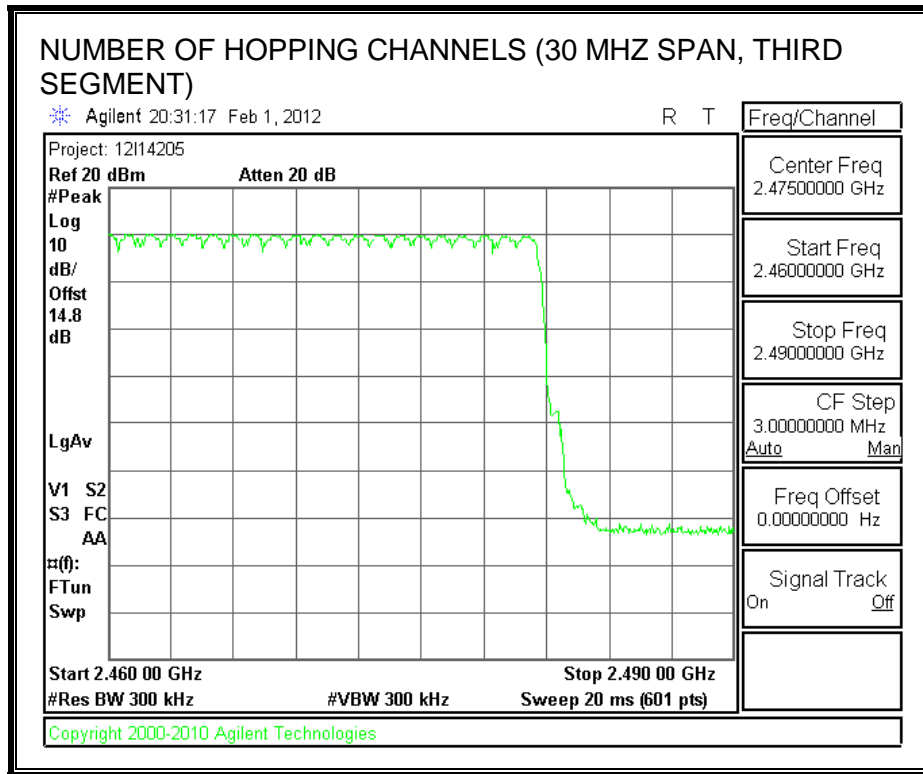

7.2.4. AVERAGE TIME OF OCCUPANCY

LIMIT

FCC §15.247 (a) (1) (iii)

The average time of occupancy on any channel shall not be greater than 0.4 seconds within a period of 0.4 seconds multiplied by the number of hopping channels employed.

TEST PROCEDURE

The transmitter output is connected to a spectrum analyzer. The span is set to 0 Hz, centered on a single, selected hopping channel. The width of a single pulse is measured in a fast scan. The number of pulses is measured in a 3.16 second scan, to enable resolution of each occurrence.

The average time of occupancy in the specified 31.6 second period (79 channels * 0.4 s) is equal to $10 * (\# \text{ of pulses in } 3.16 \text{ s}) * \text{ pulse width}$.

RESULTS

8PSK Mode

DH Packet	Pulse Width (msec)	Number of Pulses in 3.16 seconds	Average Time of Occupan cy (sec)	Limit (sec)	Margin (sec)
DH1	0.392	33	0.129	0.4	-0.271
DH3	1.633	17	0.278	0.4	-0.122
DH5	2.900	13	0.377	0.4	-0.023

DH1

PULSE WIDTH

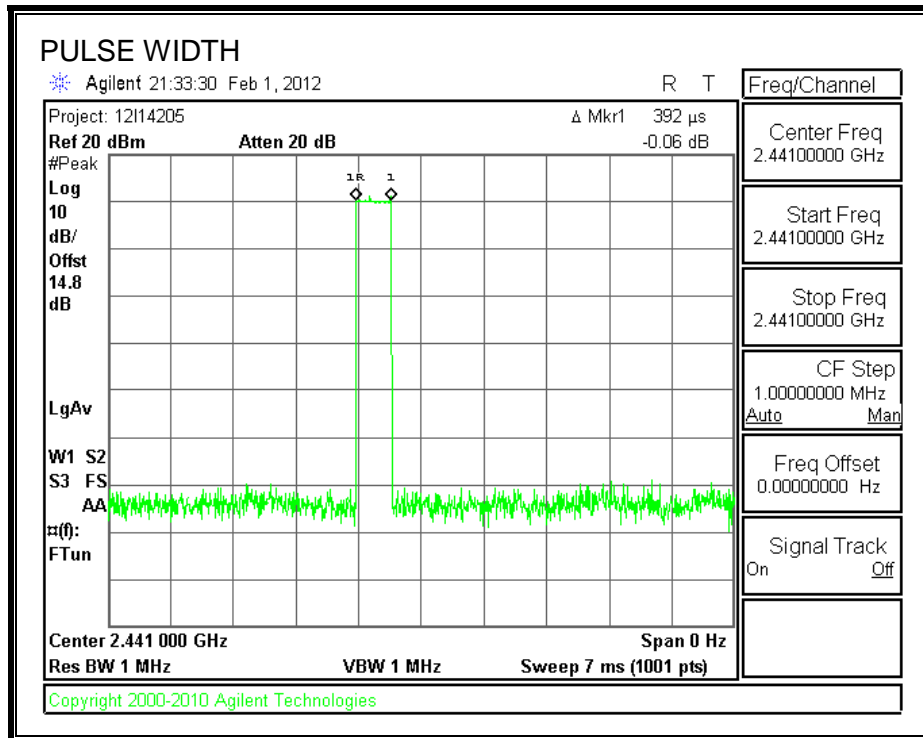

NUMBER OF PULSES IN 3.16 SECOND OBSERVATION PERIOD

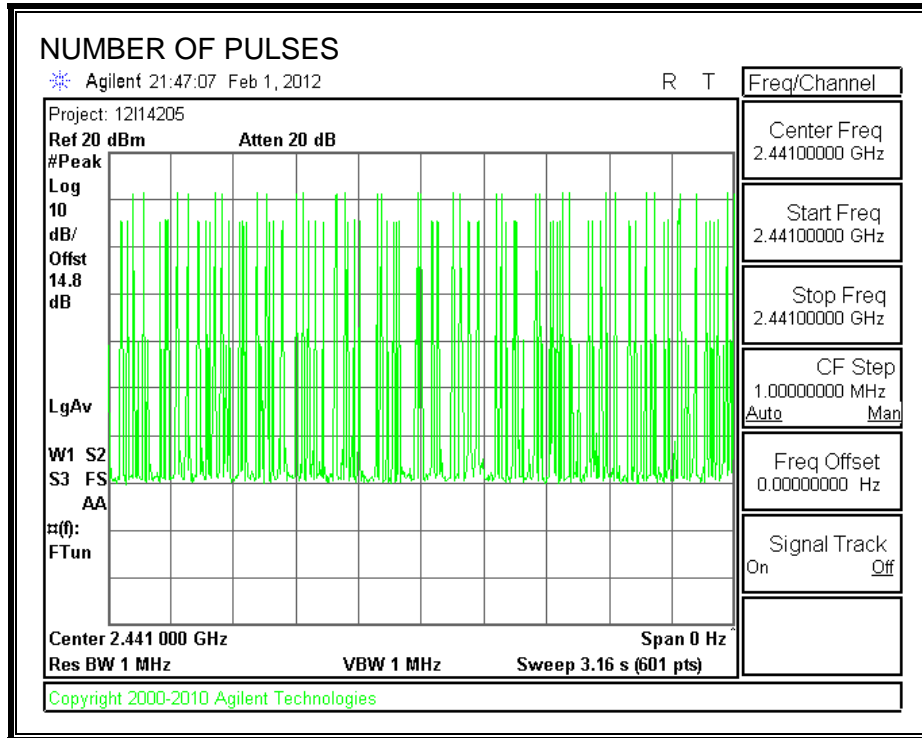

DH3

PULSE WIDTH

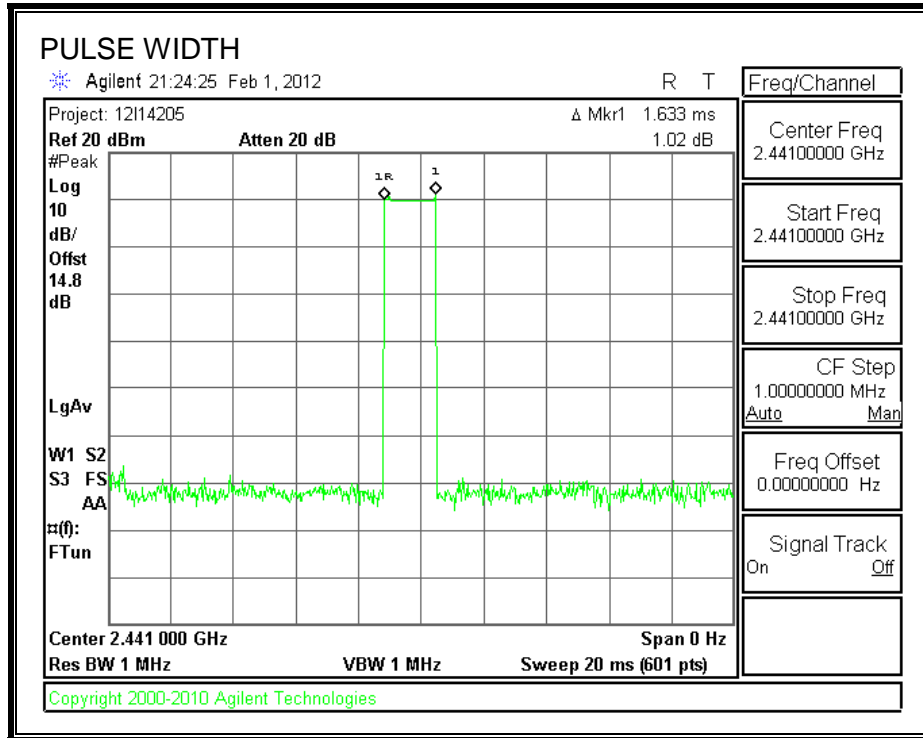

NUMBER OF PULSES IN 3.16 SECOND OBSERVATION PERIOD

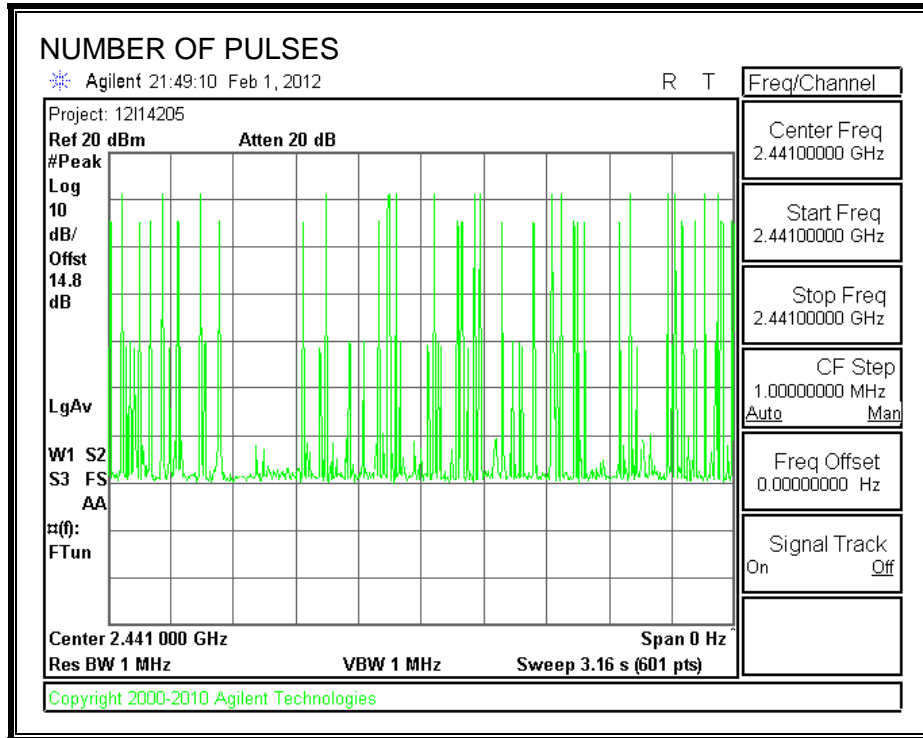

DH5

PULSE WIDTH

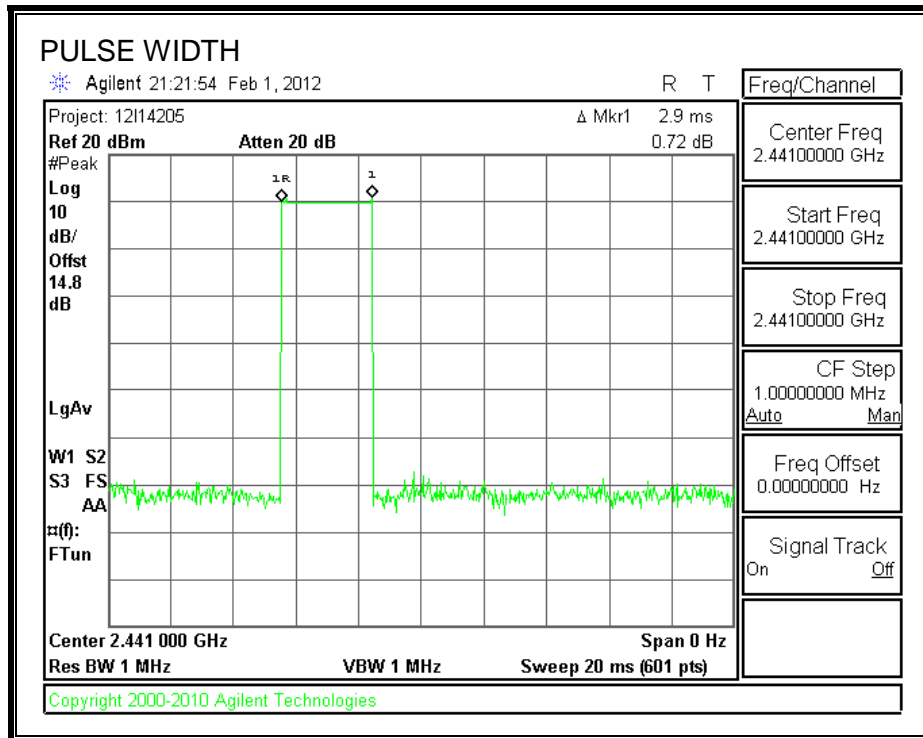

NUMBER OF PULSES IN 3.16 SECOND OBSERVATION PERIOD

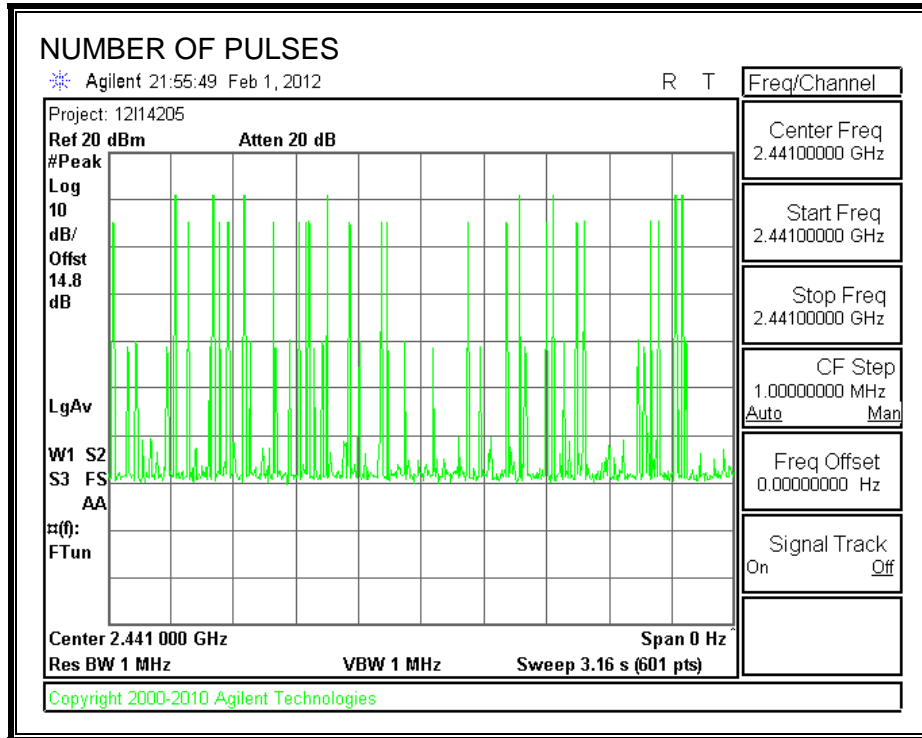

7.2.5. OUTPUT POWER

LIMIT

§15.247 (b) (1)

The maximum antenna gain is less than 6 dBi, therefore the limit is 30 dBm.

TEST PROCEDURE

The transmitter output is connected to a spectrum analyzer the analyzer bandwidth is set to a value greater than the 20 dB bandwidth of the EUT.

RESULTS

Channel	Frequency (MHz)	Output Power (dBm)	Limit (dBm)	Margin (dB)
Low	2402	11.69	30	-18.31
Middle	2441	12.15	30	-17.85
High	2480	11.91	30	-18.09

OUTPUT POWER

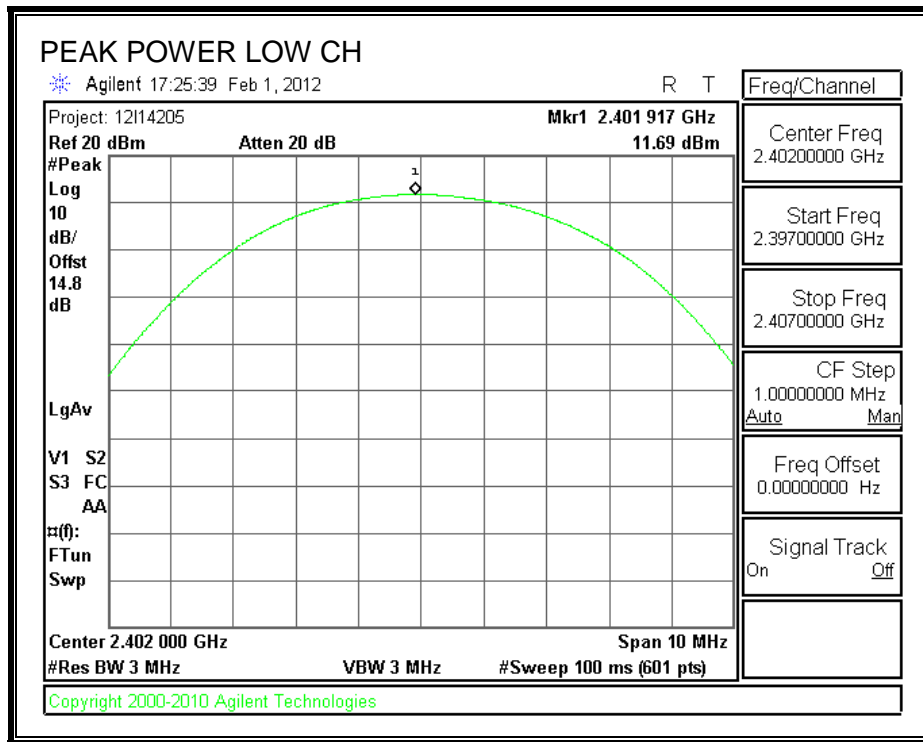

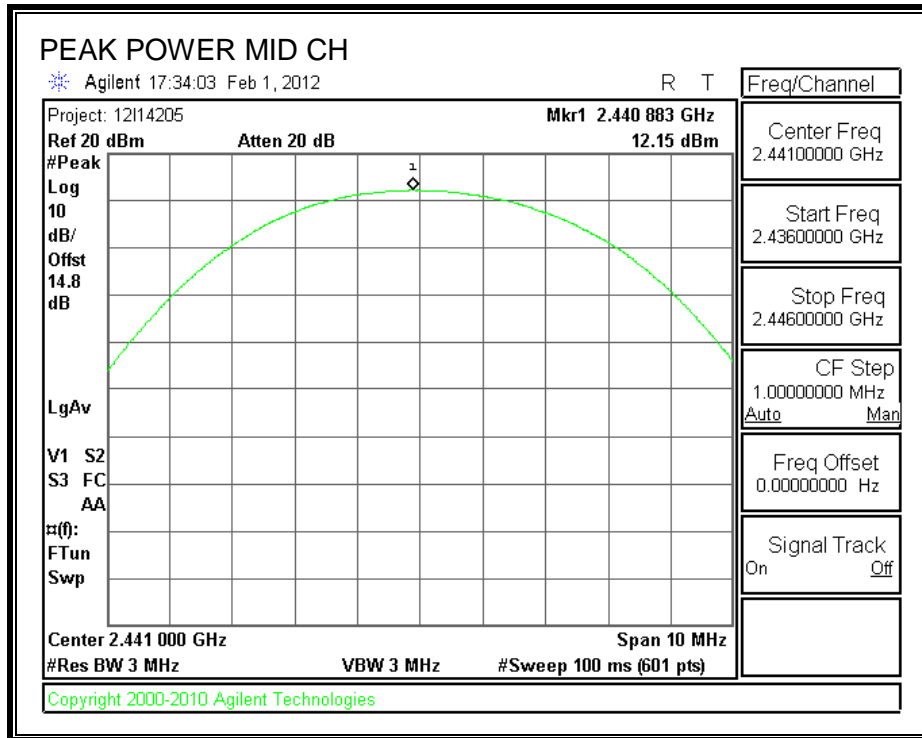

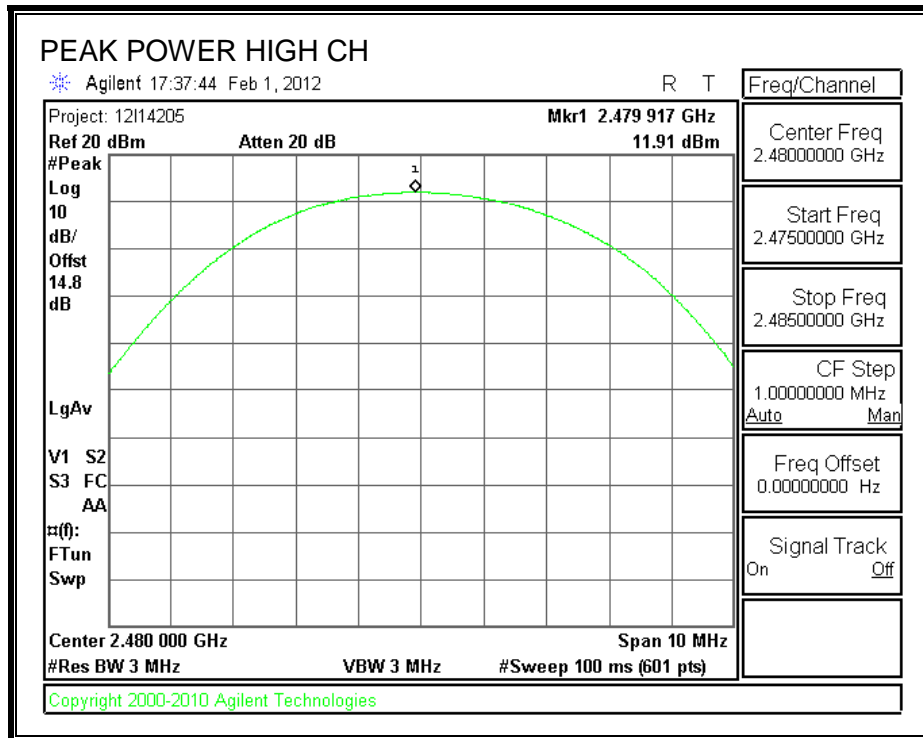

7.2.6. AVERAGE POWER

LIMIT

None; for reporting purposes only.

TEST PROCEDURE

The transmitter output is connected to a power meter.

RESULTS

The cable assembly insertion loss of 11.88 dB (including 10 dB pad and 1.88dB cable) was entered as an offset in the power meter to allow for direct reading of power.

Frequency (MHz)	Average Power (dBm)
2402	8.90
2441	9.30
2480	9.20

7.2.7. CONDUCTED SPURIOUS EMISSIONS

LIMITS

FCC §15.247 (d)

IC RSS-210 A8.5

Limit = -20 dBc

TEST PROCEDURE

The transmitter output is connected to a spectrum analyzer. The resolution bandwidth is set to 100 kHz. The video bandwidth is set to 300 kHz.

The spectrum from 30 MHz to 26 GHz is investigated with the transmitter set to the lowest, middle, and highest channels.

The bandedges at 2.4 and 2.4835 GHz are investigated with the transmitter set to the normal hopping mode.

RESULTS

SPURIOUS EMISSIONS, LOW CHANNEL

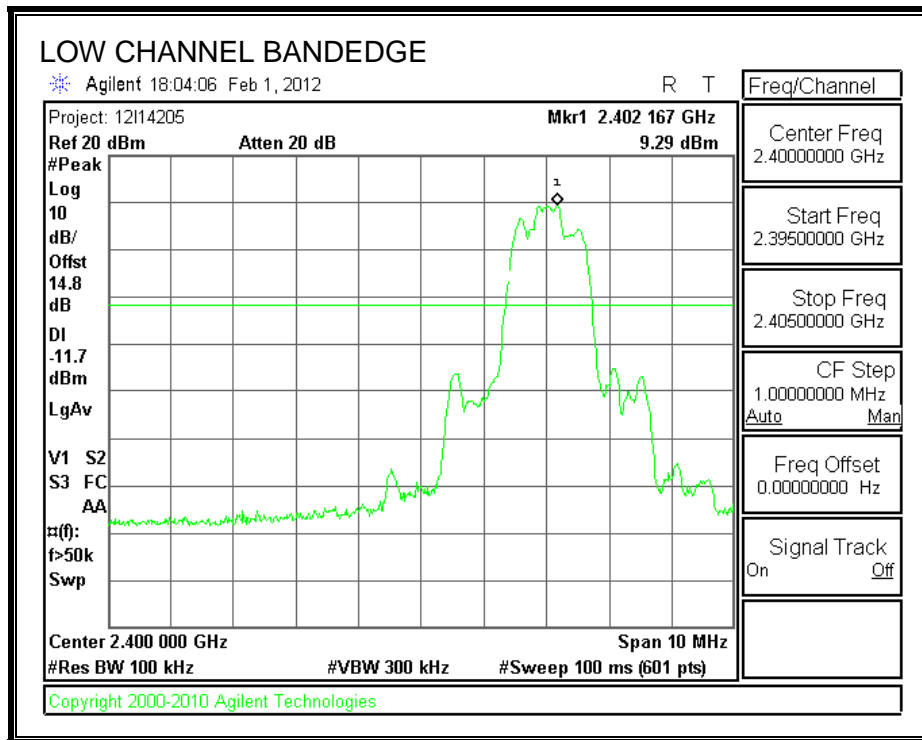

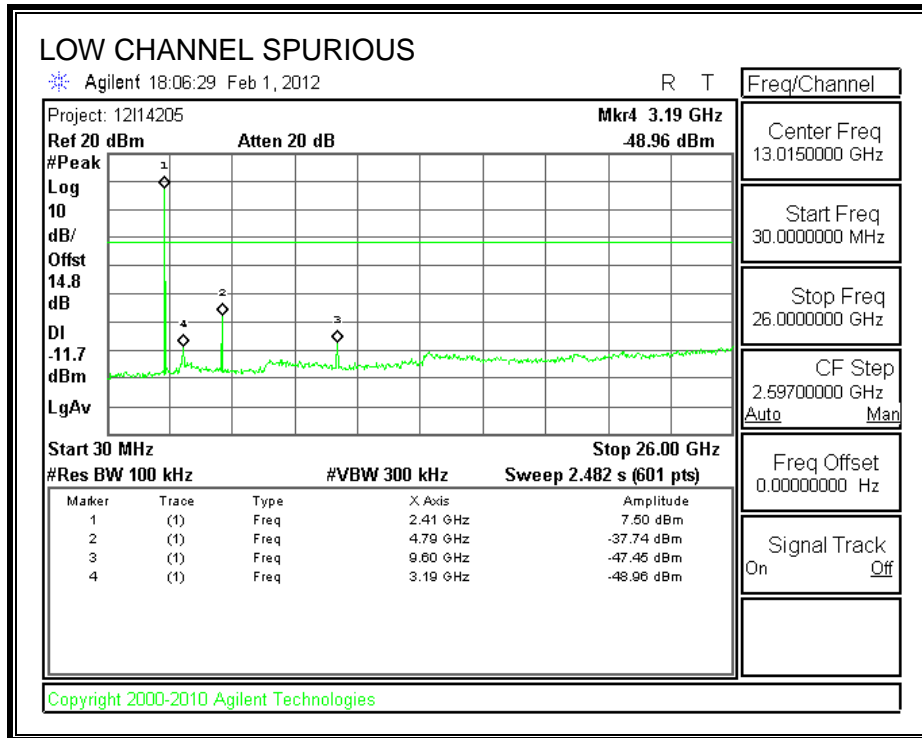

SPURIOUS EMISSIONS, MID CHANNEL

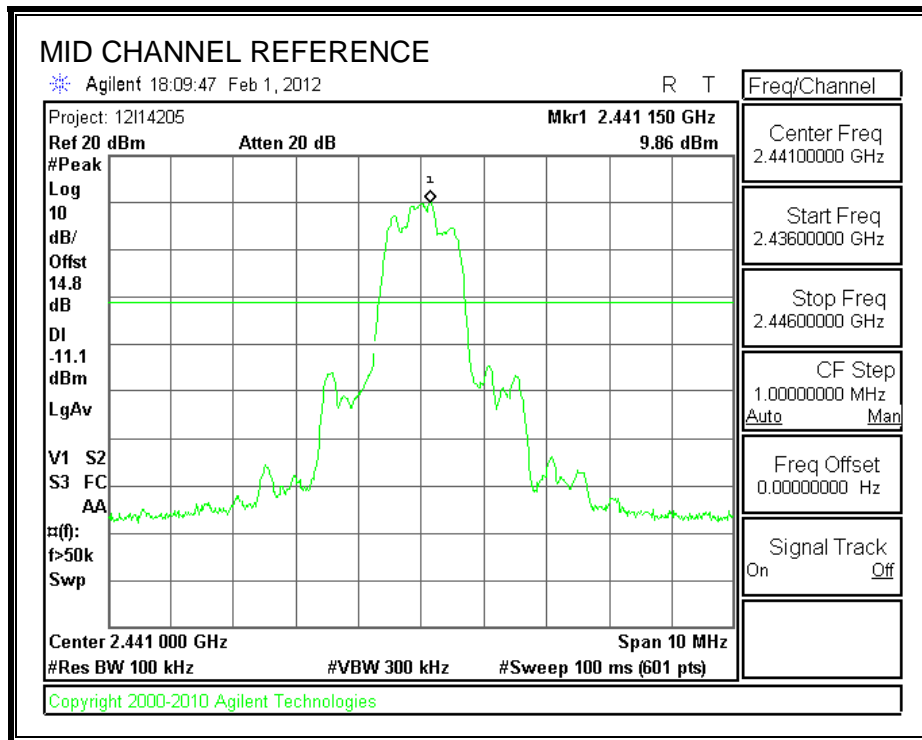

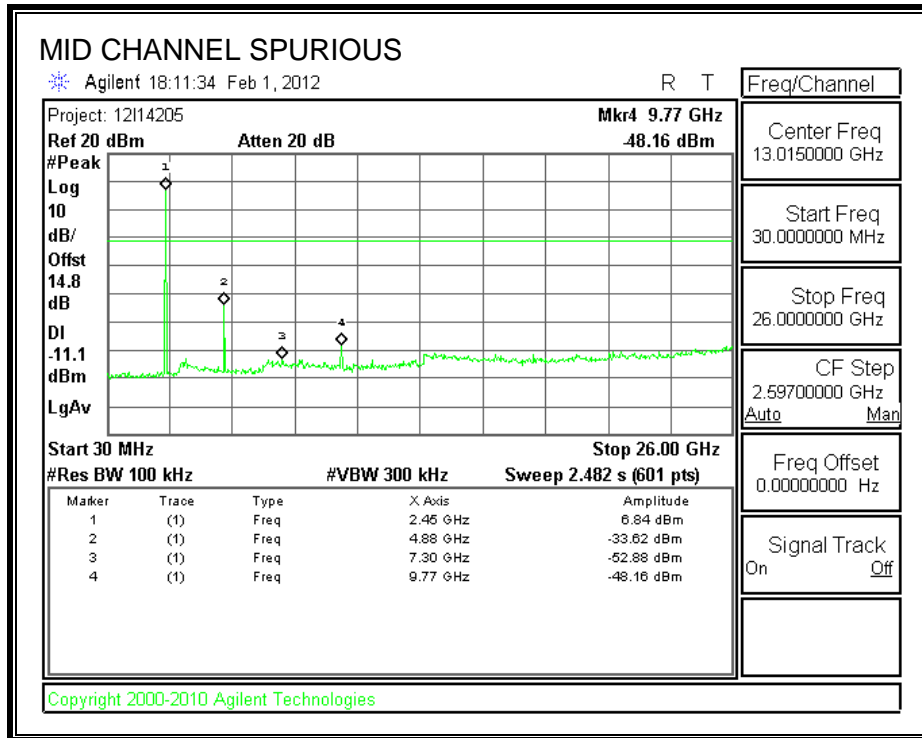

SPURIOUS EMISSIONS, HIGH CHANNEL

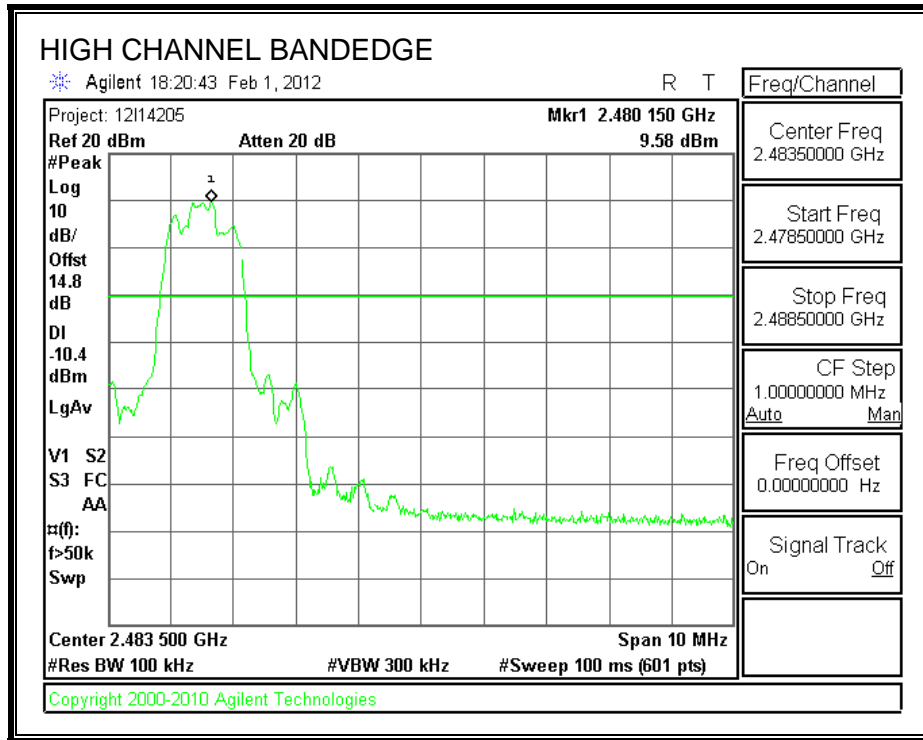

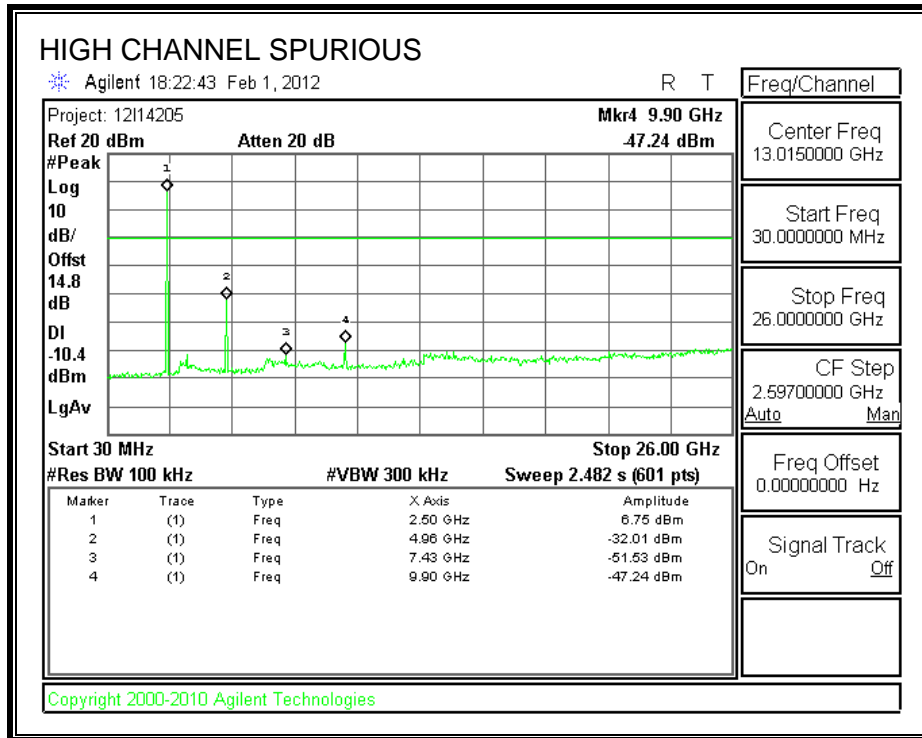

SPURIOUS BANDEDGE EMISSIONS WITH HOPPING ON

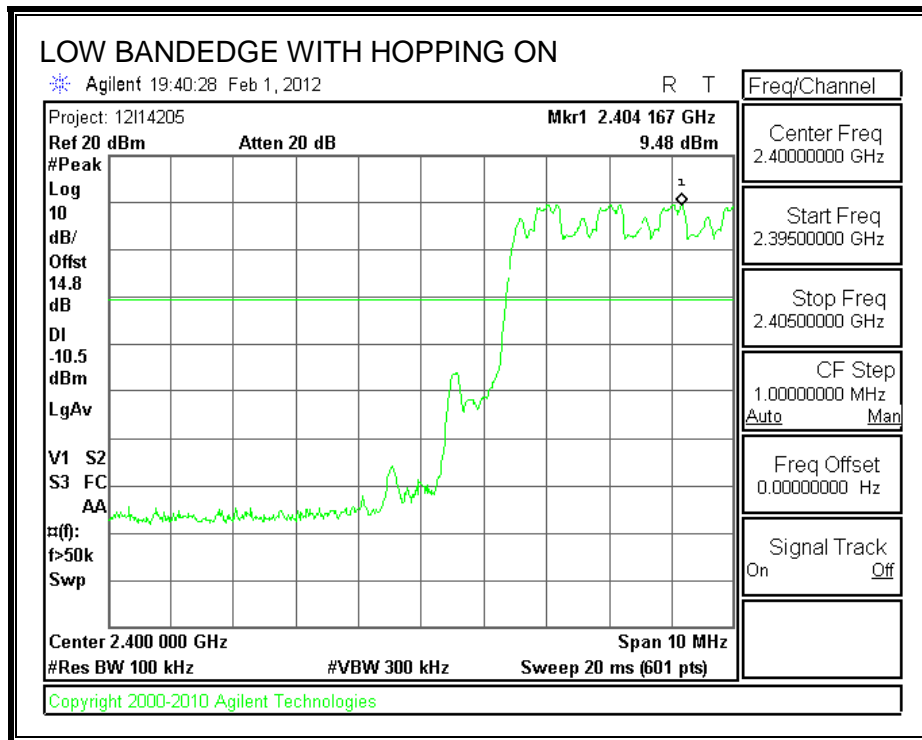

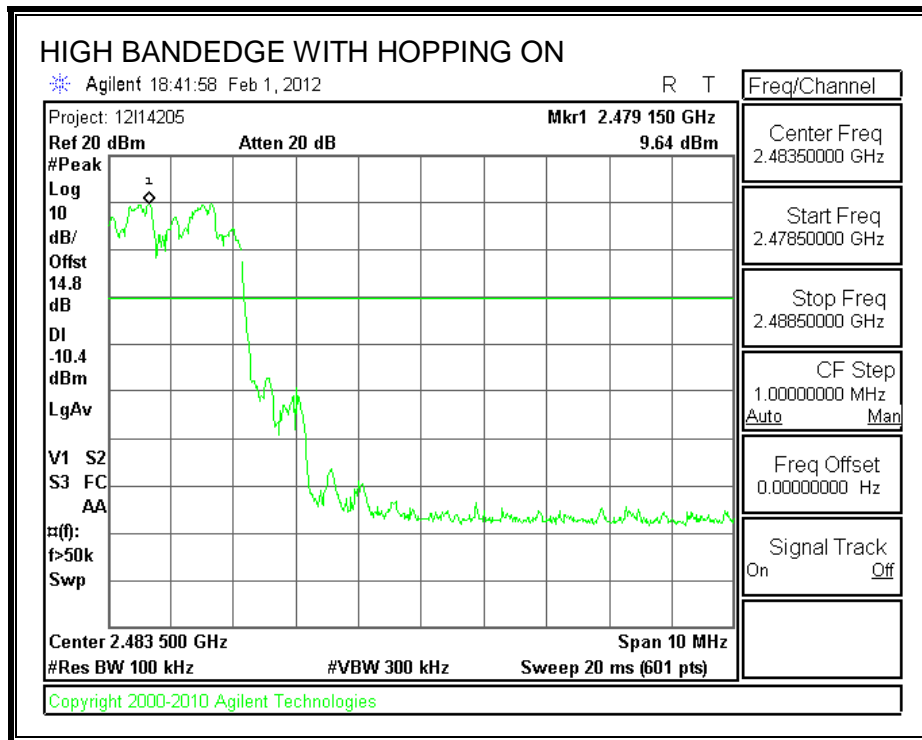

8. RADIATED TEST RESULTS

8.1. LIMITS AND PROCEDURE

LIMITS

FCC §15.205 and §15.209

Frequency Range (MHz)	Field Strength Limit (uV/m) at 3 m	Field Strength Limit (dBuV/m) at 3 m
30 - 88	100	40
88 - 216	150	43.5
216 - 960	200	46
Above 960	500	54

TEST PROCEDURE

The EUT is placed on a non-conducting table 80 cm above the ground plane. The antenna to EUT distance is 3 meters. The EUT is configured in accordance with ANSI C63.4. The EUT is set to transmit in a continuous mode.

For measurements below 1 GHz the resolution bandwidth is set to 100 kHz for peak detection measurements or 120 kHz for quasi-peak detection measurements. Peak detection is used unless otherwise noted as quasi-peak.

For measurements above 1 GHz the resolution bandwidth is set to 1 MHz, then the video bandwidth is set to 1 MHz for peak measurements and 10 Hz for average measurements.

The spectrum from 30 MHz to 26 GHz is investigated with the transmitter set to the lowest, middle, and highest channels in the 2.4 GHz band.

The frequency range of interest is monitored at a fixed antenna height and EUT azimuth. The EUT is rotated through 360 degrees to maximize emissions received. The antenna is scanned from 1 to 4 meters above the ground plane to further maximize the emission. Measurements are made with the antenna polarized in both the vertical and the horizontal positions.

8.2. TRANSMITTER ABOVE 1 GHz

8.2.1. BASIC DATA RATE GFSK MODULATION

RESTRICTED BANDEDGE (LOW CHANNEL, HORIZONTAL)

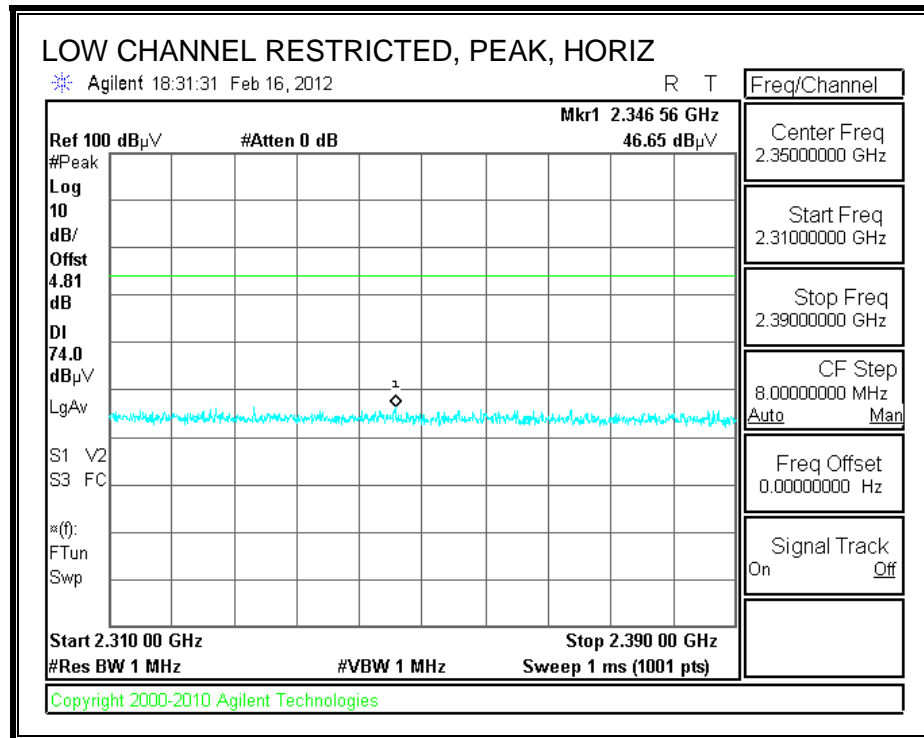

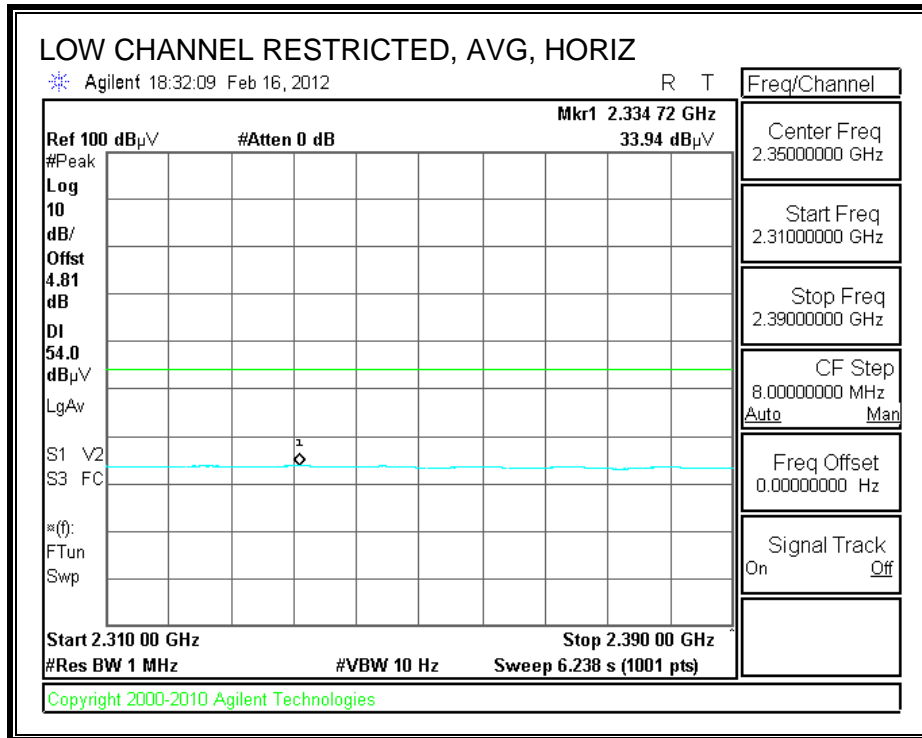

RESTRICTED BANDEDGE (LOW CHANNEL, VERTICAL)

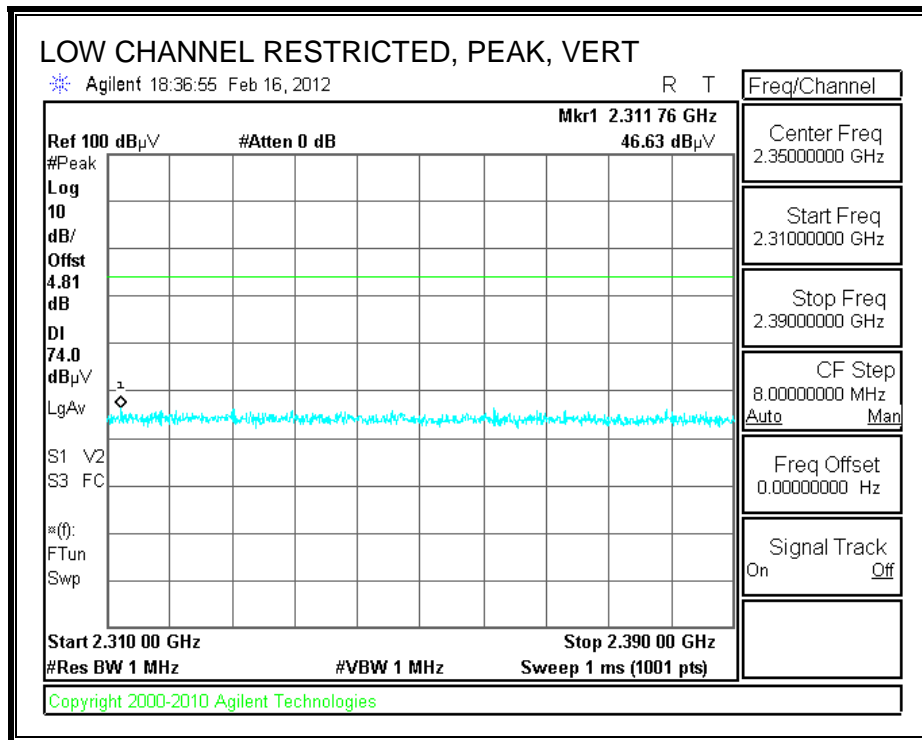

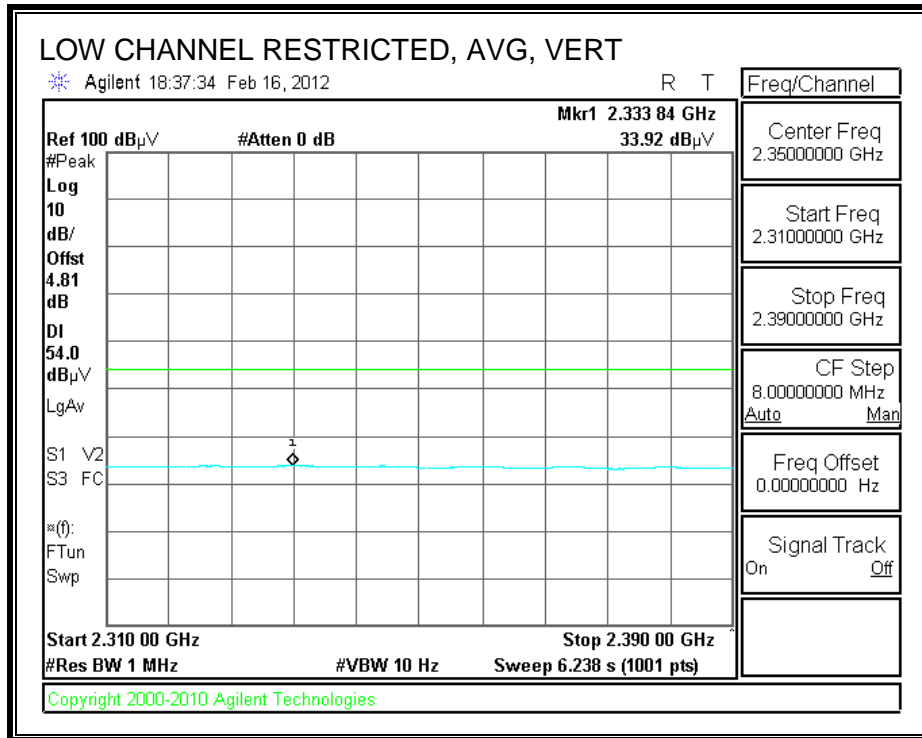

RESTRICTED BANDEDGE (HIGH CHANNEL, HORIZONTAL)

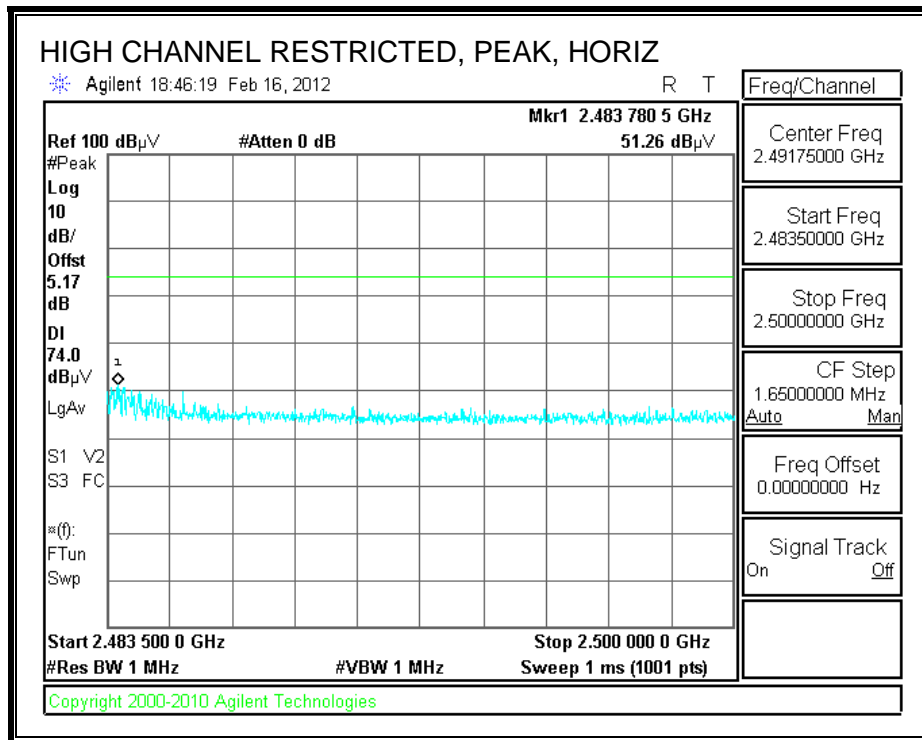

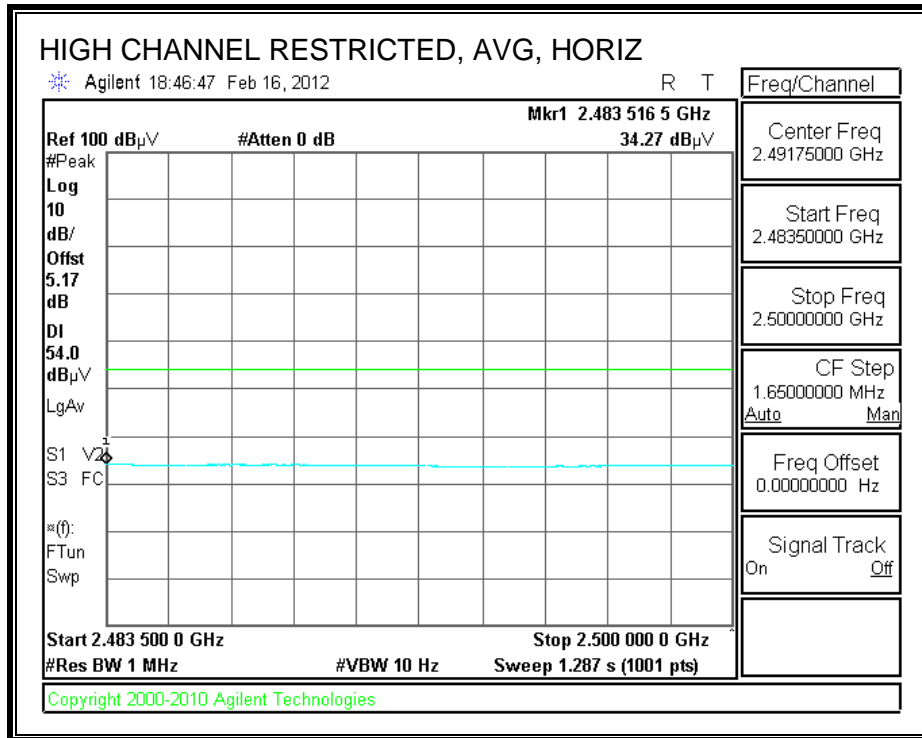

RESTRICTED BANEDGE (HIGH CHANNEL, VERTICAL)

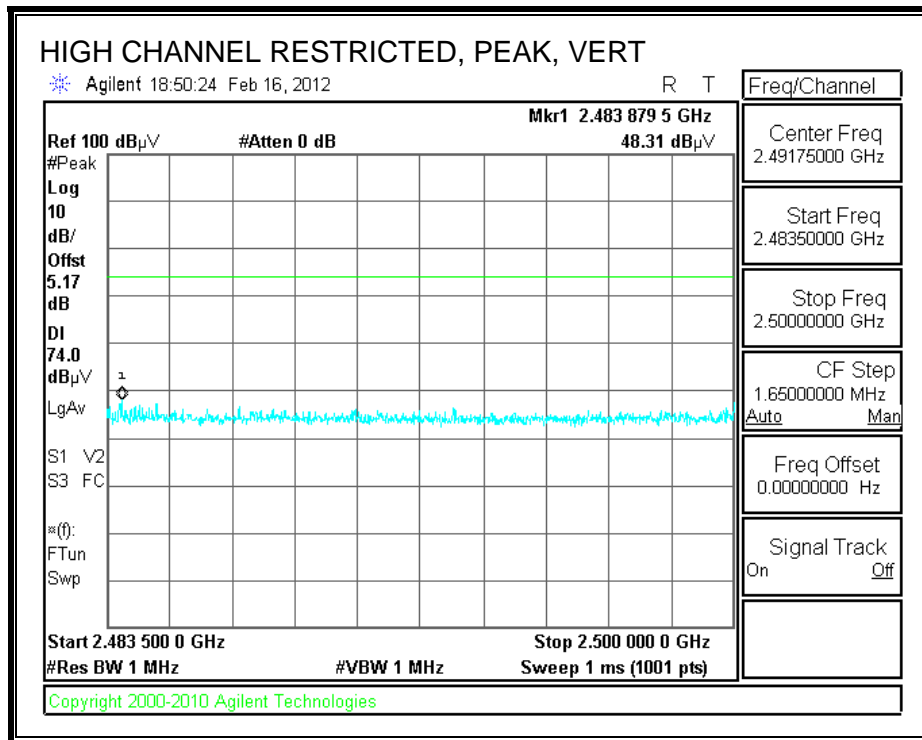

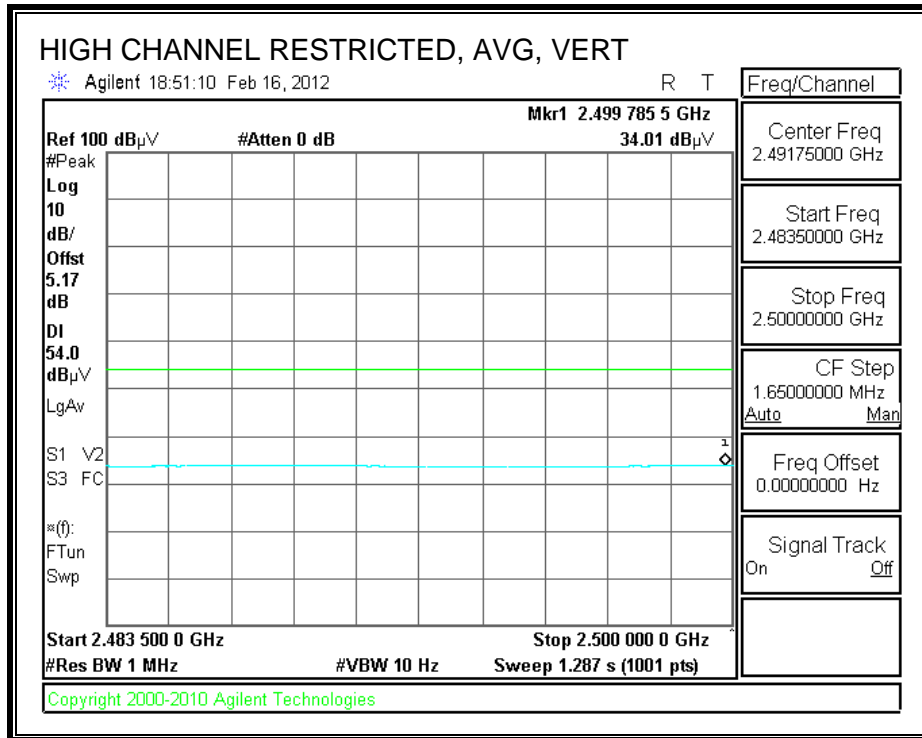

HARMONICS AND SPURIOUS EMISSIONS

High Frequency Measurement
 Compliance Certification Services, Fremont 3m Chamber

Company: Samsung Electronics
 Project #: 12114206
 Date: 2/16/2012
 Test Engineer: Steve Aguilar
 Configuration: EUT with headset (Unit S/N 3006)
 Mode: TX GFSK BT Mode

Test Equipment:

Horn 1-18GHz	Pre-amplifier 1-26GHz	Pre-amplifier 26-40GHz	Horn > 18GHz	Limit
T60; S/N: 2238 @3m	T34 HP 8449B			FCC 15.209

Hi Frequency Cables

3' cable 22807700	12' cable 22807600	20' cable 22807500	HPF	Reject Filter	Peak Measurements RBW=VBW=1MHz Average Measurements RBW=1MHz ; VBW=10Hz
3' cable 22807700	12' cable 22807600	20' cable 22807500		R_001	

f GHz	Dist (m)	Read Pk dBuV	Read Avg. dBuV	AF dB/m	CL dB	Amp dB	D Corr dB	Filtr dB	Peak dBuV/m	Avg dBuV/m	Pk Lim dBuV/m	Avg Lim dBuV/m	Pk Mar dB	Avg Mar dB	Notes (V/H)
Low Channel (2402 MHz)															
4.804	3.0	50.4	32.2	33.1	6.8	-34.1	0.0	0.0	56.2	38.0	74	54	-17.8	-16.0	H
4.804	3.0	47.7	31.1	33.1	6.8	-34.1	0.0	0.0	53.5	36.9	74	54	-20.5	-17.1	V
7.206	3.0	39.8	27.3	36.2	9.1	-33.2	0.0	0.0	51.9	39.3	74	54	-22.1	-14.7	H
7.206	3.0	38.8	26.7	36.2	9.1	-33.2	0.0	0.0	50.9	38.8	74	54	-23.1	-15.2	V
12.010	3.0	34.7	22.6	39.4	11.9	-32.3	0.0	0.0	53.6	41.6	74	54	-20.4	-12.4	H
12.010	3.0	36.0	22.6	39.4	11.9	-32.3	0.0	0.0	54.9	41.6	74	54	-19.1	-12.4	V
Mid Channel (2441 MHz)															
4.882	3.0	52.4	32.8	33.2	6.8	-34.0	0.0	0.0	58.4	38.7	74	54	-15.6	-15.3	H
4.882	3.0	51.6	32.4	33.2	6.8	-34.0	0.0	0.0	57.6	38.3	74	54	-16.4	-15.7	V
7.323	3.0	40.8	27.5	36.3	9.1	-33.1	0.0	0.0	53.1	39.8	74	54	-20.9	-14.2	H
7.323	3.0	39.6	26.9	36.3	9.1	-33.1	0.0	0.0	51.9	39.2	74	54	-22.1	-14.8	V
12.205	3.0	35.0	22.9	39.4	12.0	-32.3	0.0	0.0	54.0	42.0	74	54	-20.0	-12.0	H
12.205	3.0	35.2	22.8	39.4	12.0	-32.3	0.0	0.0	54.3	41.9	74	54	-19.7	-12.1	V
High Channel (2480 MHz)															
4.960	3.0	55.8	33.9	33.2	6.9	-34.0	0.0	0.0	61.9	40.0	74	54	-12.1	-14.0	H
4.960	3.0	51.3	32.2	33.2	6.9	-34.0	0.0	0.0	57.3	38.2	74	54	-16.7	-15.8	V
7.440	3.0	42.2	28.3	36.5	9.1	-33.0	0.0	0.0	54.7	40.9	74	54	-19.3	-13.1	H
7.440	3.0	41.2	27.7	36.5	9.1	-33.0	0.0	0.0	53.7	40.2	74	54	-20.3	-13.8	V
12.400	3.0	34.2	21.5	39.4	12.0	-32.3	0.0	0.0	53.4	40.7	74	54	-20.6	-13.3	H
12.400	3.0	34.4	21.5	39.4	12.0	-32.3	0.0	0.0	53.6	40.6	74	54	-20.4	-13.4	V

Rev. 07.08.11

f	Measurement Frequency	Amp	Preamp Gain	Avg Lim	Average Field Strength Limit
Dist	Distance to Antenna	D Corr	Distance Correct to 3 meters	Pk Lim	Peak Field Strength Limit
Read	Analyzer Reading	Avg	Average Field Strength @ 3 m	Avg Mar	Margin vs. Average Limit
AF	Antenna Factor	Peak	Calculated Peak Field Strength	Pk Mar	Margin vs. Peak Limit
CL	Cable Loss	HPF	High Pass Filter		

8.2.2. ENHANCED DATA RATE 8PSK MODULATION

RESTRICTED BANDEDGE (LOW CHANNEL, HORIZONTAL)

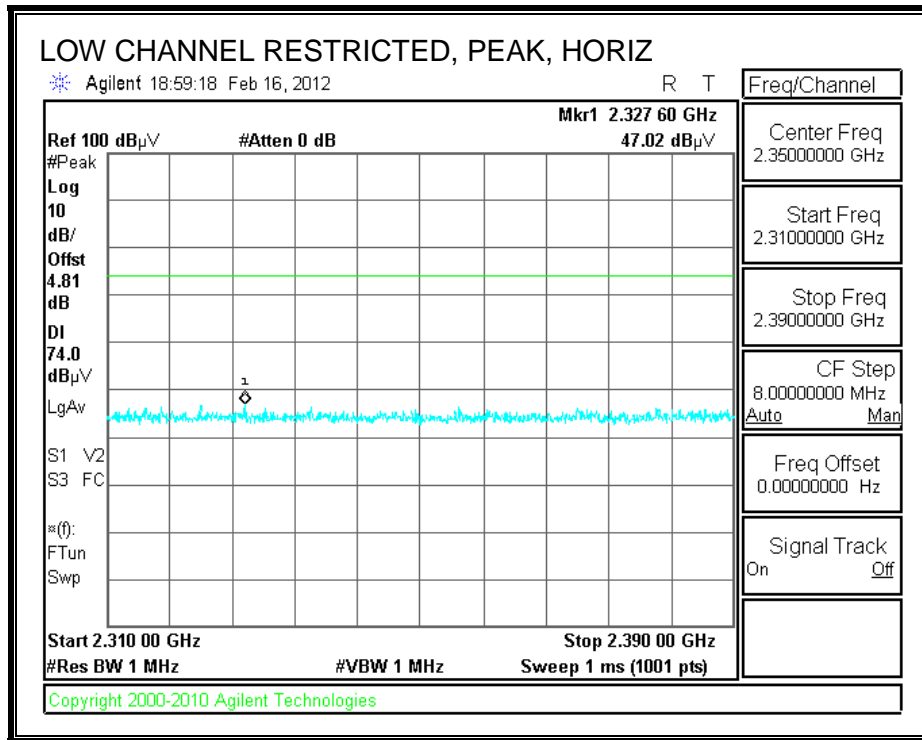

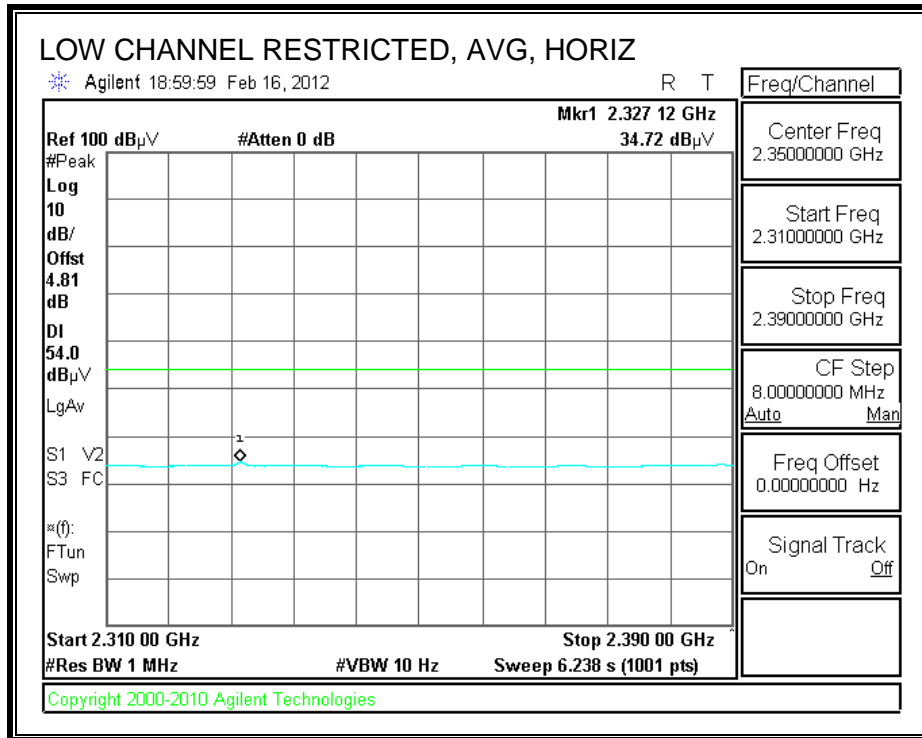

RESTRICTED BANDEDGE (LOW CHANNEL, VERTICAL)

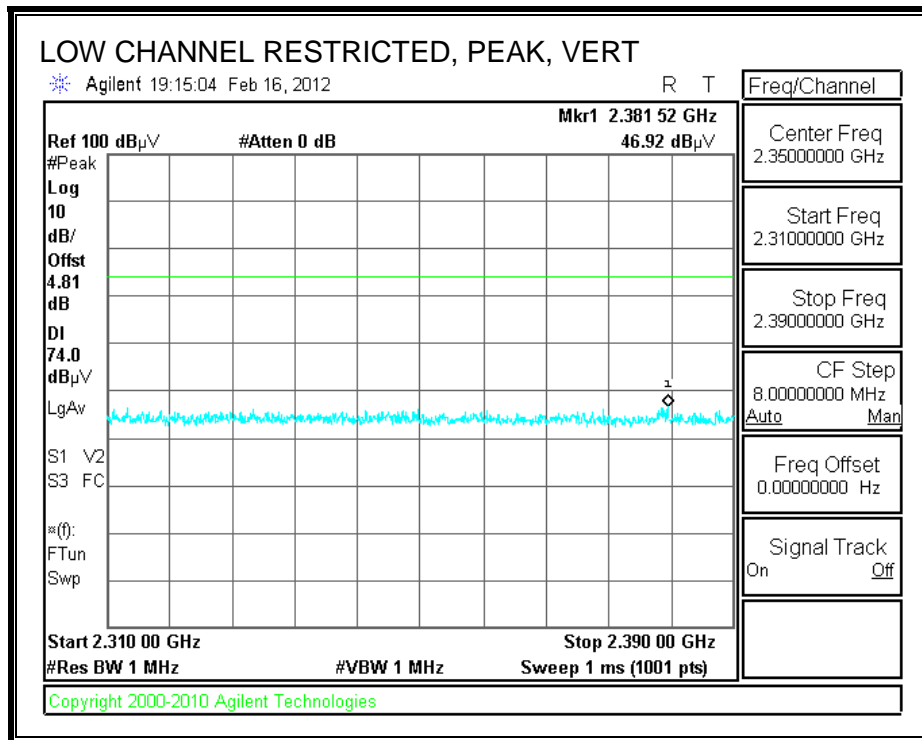

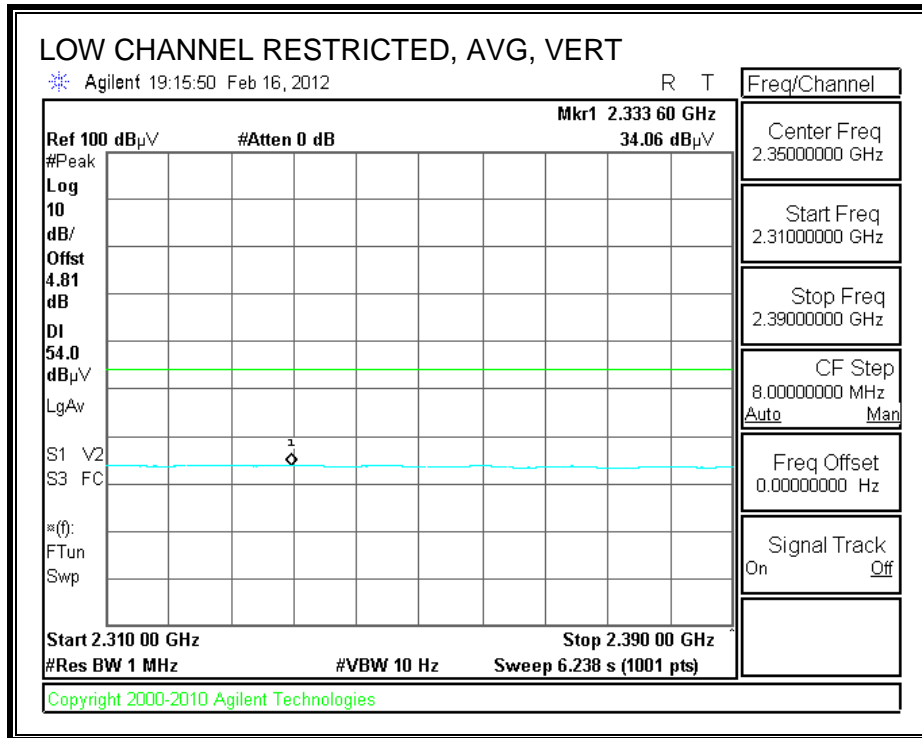

RESTRICTED BANDEDGE (HIGH CHANNEL, HORIZONTAL)

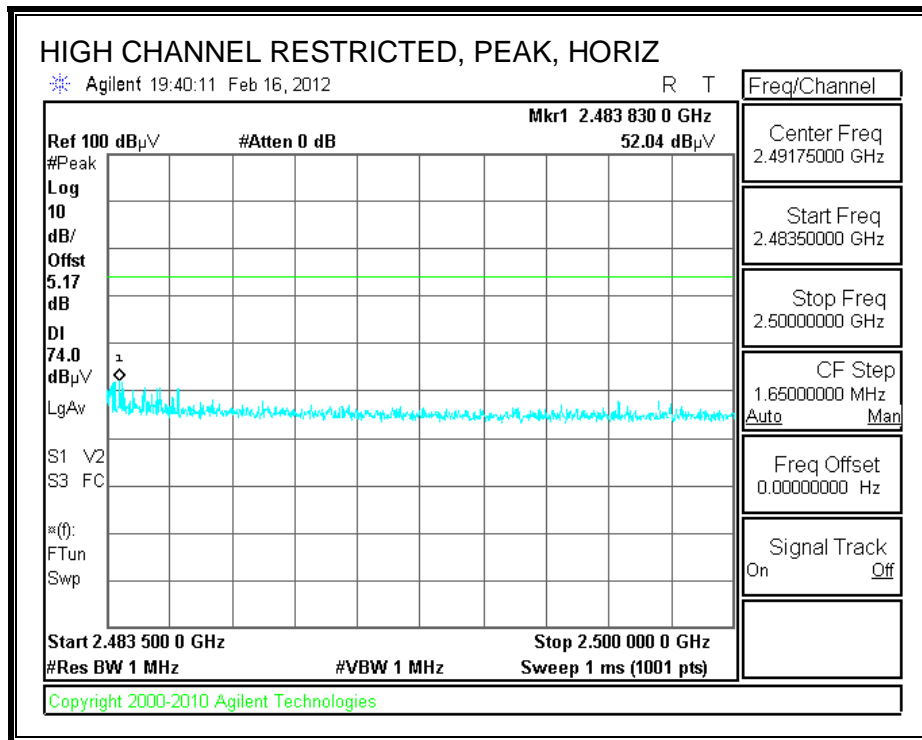

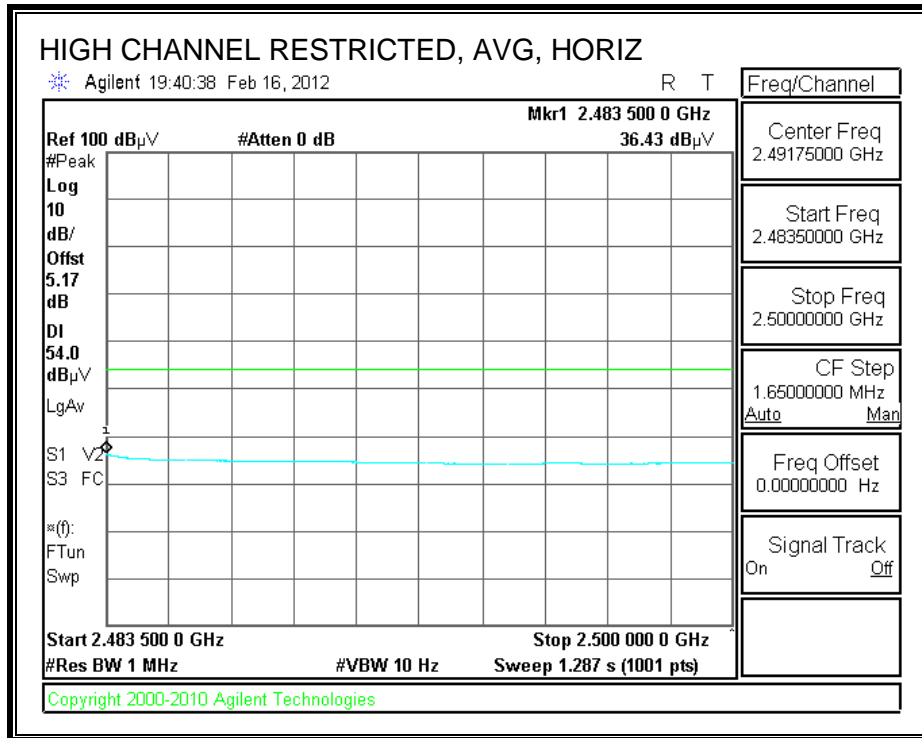

RESTRICTED BANEDGE (HIGH CHANNEL, VERTICAL)

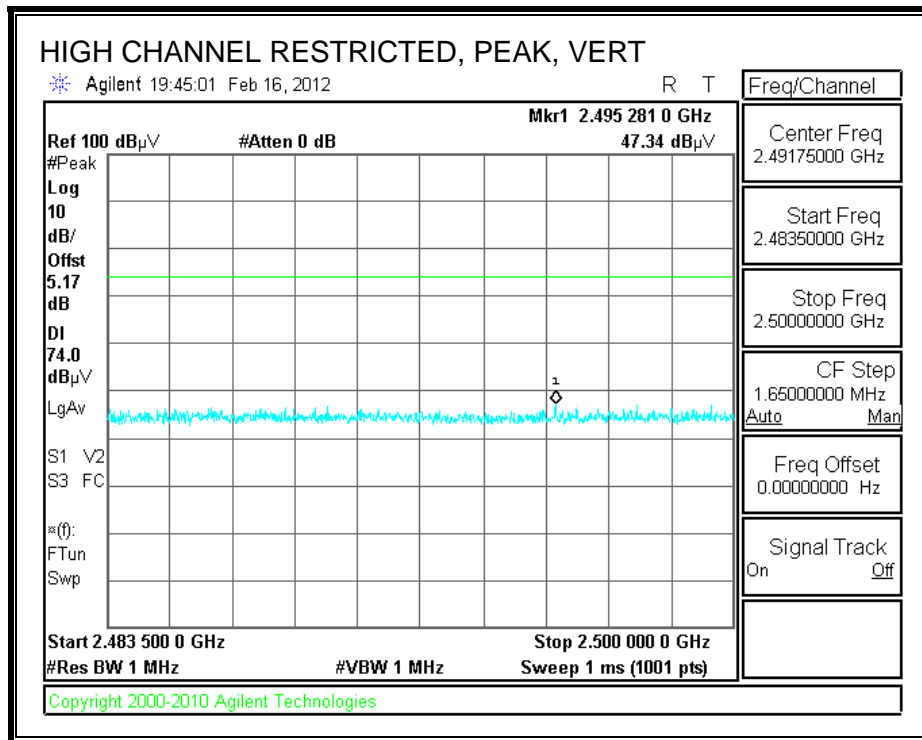

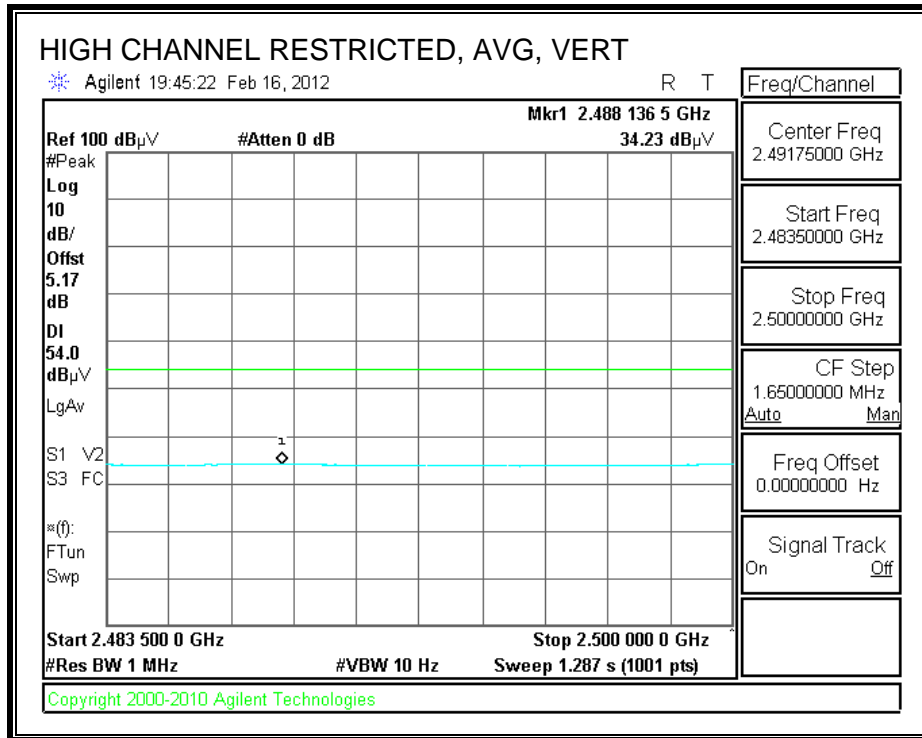

HARMONICS AND SPURIOUS EMISSIONS

High Frequency Measurement																							
Compliance Certification Services, Fremont 3m Chamber																							
Company:		Samsung Electronics																					
Project #:		12114206																					
Date:		2/16/2012																					
Test Engineer:		Steve Aguilar																					
Configuration:		EUT with headset (Unit S/N 3006)																					
Mode:		TX 8PSK BT Mode																					
Test Equipment:																							
Horn 1-18GHz				Pre-amplifier 1-26GHz				Pre-amplifier 26-40GHz				Horn > 18GHz				Limit							
T60; S/N: 2238 @3m				T34 HP 8449B												FCC 15.209							
Hi Frequency Cables																							
3' cable 22807700				12' cable 22807600				20' cable 22807500				HPF				Reject Filter				Peak Measurements RBW=VBW=1MHz			
3' cable 22807700				12' cable 22807600				20' cable 22807500								R_001				Average Measurements RBW=1MHz ; VBW=10Hz			
f GHz	Dist (m)	Read Pk dBuV	Read Avg. dBuV	AF dB/m	CL dB	Amp dB	D Corr dB	Filtr dB	Peak dBuV/m	Avg dBuV/m	Pk Lim dBuV/m	Avg Lim dBuV/m	Pk Mar dB	Avg Mar dB	Notes (V/H)								
Low Channel (2402 MHz)																							
4.804	3.0	48.5	40.9	33.1	6.8	-34.1	0.0	0.0	54.3	46.7	74	54	-19.7	-7.3	H								
4.804	3.0	46.5	38.5	33.1	6.8	-34.1	0.0	0.0	52.3	44.3	74	54	-21.7	-9.7	V								
7.206	3.0	38.0	27.8	36.2	9.1	-33.2	0.0	0.0	50.1	39.9	74	54	-23.9	-14.1	H								
7.206	3.0	36.9	25.9	36.2	9.1	-33.2	0.0	0.0	49.0	37.9	74	54	-25.0	-16.1	V								
12.010	3.0	35.0	22.6	39.4	11.9	-32.3	0.0	0.0	53.9	41.6	74	54	-20.1	-12.4	H								
12.010	3.0	34.7	22.6	39.4	11.9	-32.3	0.0	0.0	53.6	41.6	74	54	-20.4	-12.4	V								
Mid Channel (2441 MHz)																							
4.882	3.0	49.8	42.1	33.2	6.8	-34.0	0.0	0.0	55.8	48.1	74	54	-18.2	-5.9	H								
4.882	3.0	47.8	39.7	33.2	6.8	-34.0	0.0	0.0	53.7	45.6	74	54	-20.3	-8.4	V								
7.323	3.0	38.1	28.0	36.3	9.1	-33.1	0.0	0.0	50.4	40.3	74	54	-23.6	-13.7	H								
7.323	3.0	37.5	27.4	36.3	9.1	-33.1	0.0	0.0	49.8	39.7	74	54	-24.2	-14.3	V								
12.205	3.0	35.8	22.9	39.4	12.0	-32.3	0.0	0.0	54.8	42.0	74	54	-19.2	-12.0	H								
12.205	3.0	35.0	22.9	39.4	12.0	-32.3	0.0	0.0	54.1	42.0	74	54	-19.9	-12.0	V								
High Channel (2480 MHz)																							
4.960	3.0	53.5	42.7	33.2	6.9	-34.0	0.0	0.0	59.5	48.8	74	54	-14.5	-5.2	H								
4.960	3.0	51.7	41.2	33.2	6.9	-34.0	0.0	0.0	57.7	47.2	74	54	-16.3	-6.8	V								
7.440	3.0	39.7	30.0	36.5	9.1	-33.0	0.0	0.0	52.3	42.6	74	54	-21.7	-11.4	H								
7.440	3.0	37.8	27.3	36.5	9.1	-33.0	0.0	0.0	50.3	39.8	74	54	-23.7	-14.2	V								
12.400	3.0	34.0	21.7	39.4	12.0	-32.3	0.0	0.0	53.1	40.8	74	54	-20.9	-13.2	H								
12.400	3.0	34.0	21.6	39.4	12.0	-32.3	0.0	0.0	53.2	40.7	74	54	-20.8	-13.3	V								
Rev. 07.08.11																							
f	Measurement Frequency					Amp	Preamp Gain					Avg Lim	Average Field Strength Limit										
Dist	Distance to Antenna					D Corr	Distance Correct to 3 meters					Pk Lim	Peak Field Strength Limit										
Read	Analyzer Reading					Avg	Average Field Strength @ 3 m					Avg Mar	Margin vs. Average Limit										
AF	Antenna Factor					Peak	Calculated Peak Field Strength					Pk Mar	Margin vs. Peak Limit										
CL	Cable Loss					HPF	High Pass Filter																

8.3. WORST-CASE BELOW 1 GHz

SPURIOUS EMISSIONS 30 TO 1000 MHz (WORST-CASE CONFIGURATION, HORIZONTAL)

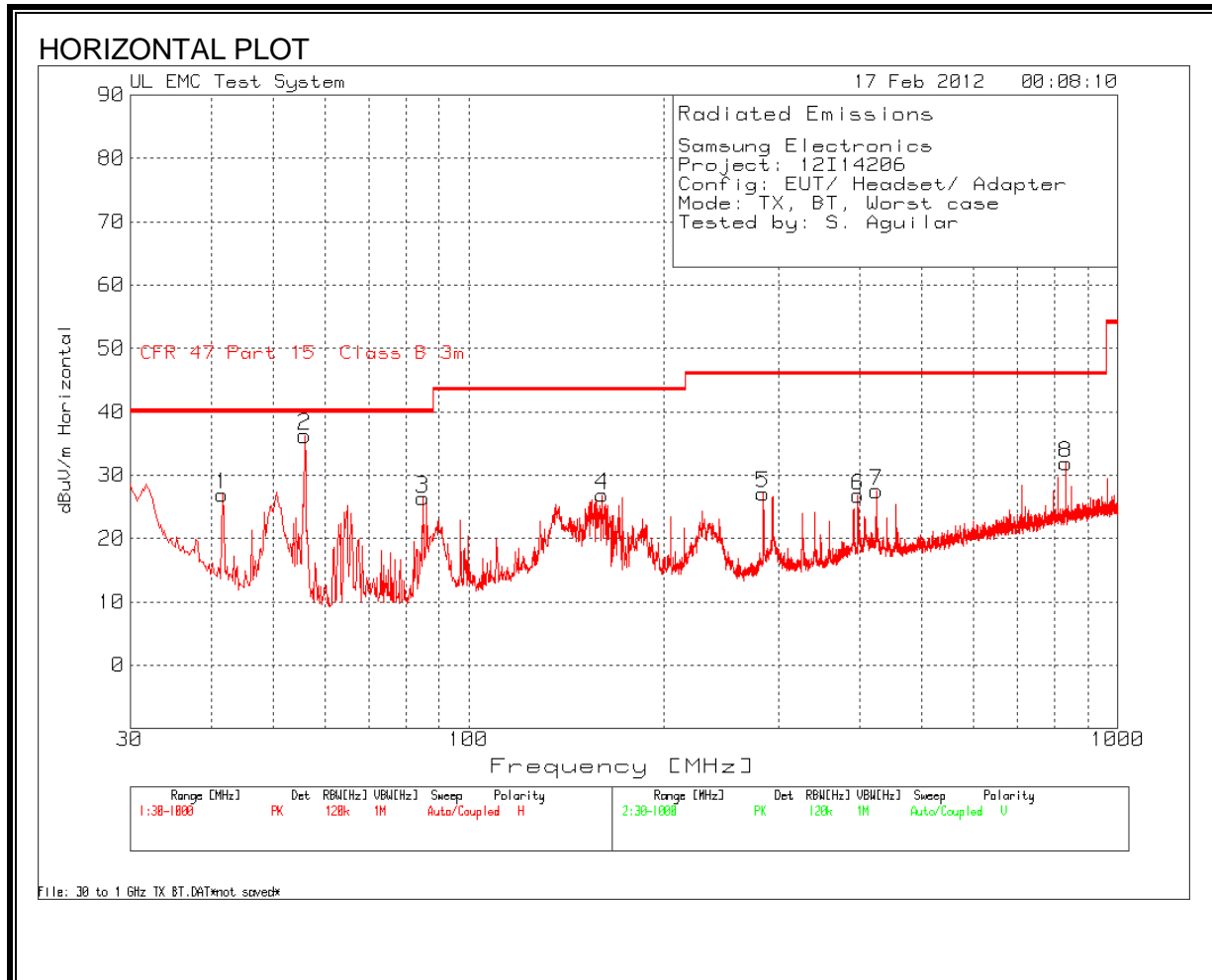

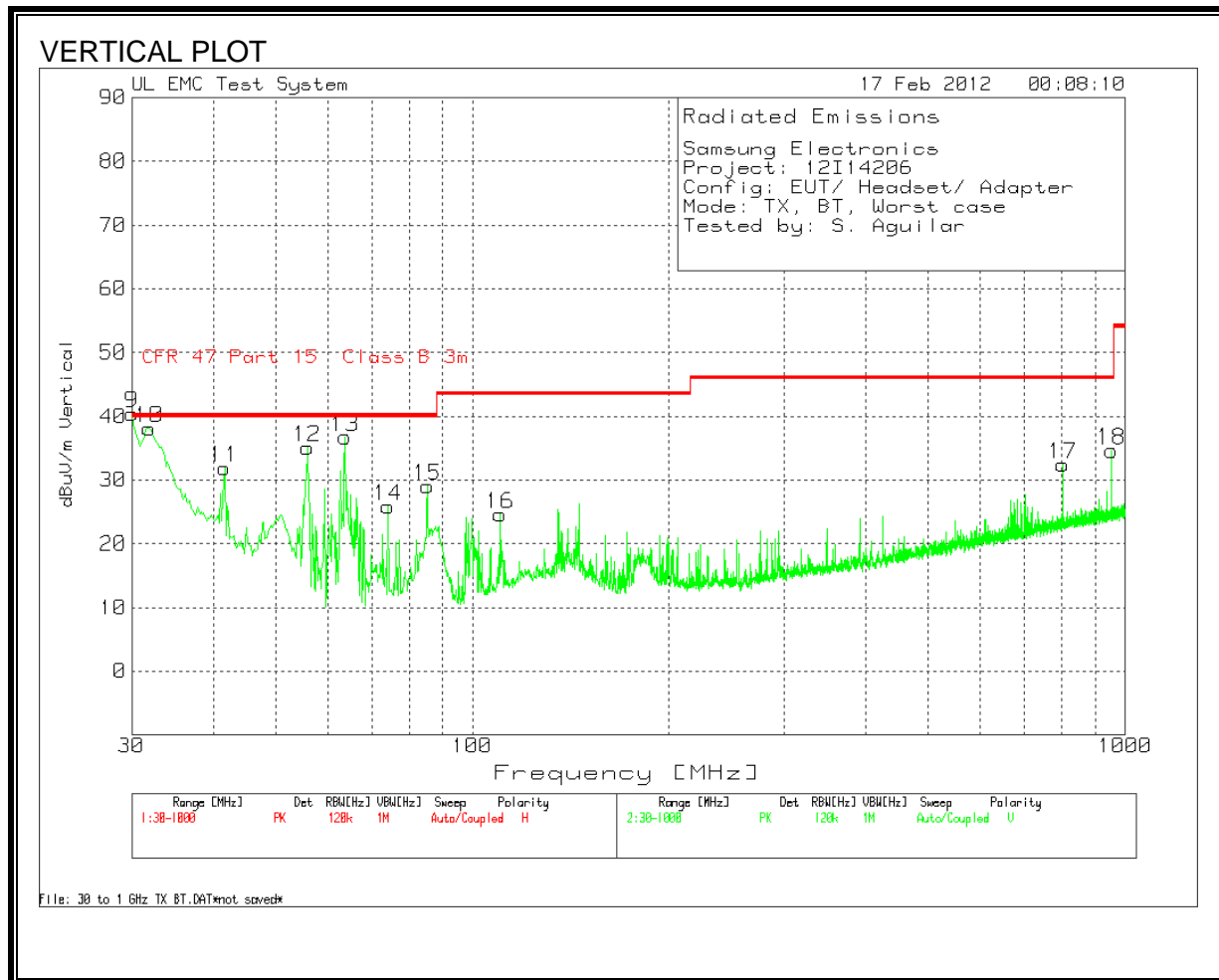

HORIZONTAL AND VERTICAL DATA

Samsung Electronics
 Project: 12114206
 Date: 2-17-2012
 Config: EUT/ Headset/ Adapter
 Mode: TX, BT, Worst case
 Tested by: S. Aguilar

Test Frequency	Meter Reading	Detector	Amplifier [dB]	T130 Bilog [dB]	Corrected dBuV/m	Class B 3m limit	QP Margin	Height [cm]	Polarity
Range 1 30 - 1000MHz									
41.6307	41.44	PK	-27.4	12.9	26.94	40	-13.06	300	Horz
55.7814	55.47	PK	-27.3	8.1	36.27	40	-3.73	200	Horz
50.9031	41.34	QP	-27.2	8.3	22.44	40	-17.56	295	Horz
84.8581	46.05	PK	-27.1	7.4	26.35	40	-13.65	400	Horz
160.4576	41.78	PK	-26.5	11.6	26.88	43.5	-16.62	200	Horz
284.3245	40	PK	-25.8	12.9	27.1	46	-18.9	100	Horz
398.1115	37.21	PK	-25.3	14.9	26.81	46	-19.19	100	Horz
425.056	37.42	PK	-25.3	15.4	27.52	46	-18.48	200	Horz
833.0995	33.78	PK	-23.2	21.3	31.88	46	-14.12	200	Horz
Range 2 30 - 1000MHz									
30	47.84	PK	-27.5	20.1	40.44	40	0.44	100	Vert
30.1242	42.62	QP	-27.5	20	35.12	40	-4.88	100	Vert
31.9384	46.31	PK	-27.5	19.3	38.11	40	-1.89	100	Vert
31.9084	43.74	QP	-27.5	19.3	35.54	40	-4.46	101	Vert
41.6307	46.37	PK	-27.4	12.9	31.87	40	-8.13	200	Vert
55.7814	54.29	PK	-27.3	8.1	35.09	40	-4.91	300	Vert
63.729	55.94	PK	-27.2	8	36.74	40	-3.26	100	Vert
63.6491	24.22	QP	-27.2	8	5.02	40	-34.98	356	Vert
74.1966	45.23	PK	-27.1	7.7	25.83	40	-14.17	200	Vert
85.2458	48.63	PK	-27	7.4	29.03	40	-10.97	200	Vert
110.2518	39.49	PK	-26.7	11.8	24.59	43.5	-18.91	100	Vert
802.8597	34.72	PK	-23.3	21	32.42	46	-13.58	100	Vert
953.8649	35.65	PK	-23.2	22.2	34.65	46	-11.35	200	Vert

PK - Peak detector
 QP - Quasi-peak detector

9. AC POWER LINE CONDUCTED EMISSIONS

LIMITS

FCC §15.207 (a)

Frequency of Emission (MHz)	Conducted Limit (dBuV)	
	Quasi-peak	Average
0.15-0.5	66 to 56*	56 to 46*
0.5-5	56	46
5-30	60	50

*Decreases with the logarithm of the frequency.

TEST PROCEDURE

The EUT is placed on a non-conducting table 40 cm from the vertical ground plane and 80 cm above the horizontal ground plane. The EUT is configured in accordance with ANSI C63.4.

The receiver is set to a resolution bandwidth of 9 kHz. Peak detection is used unless otherwise noted as quasi-peak or average.

Line conducted data is recorded for both NEUTRAL and HOT lines.

RESULTS

6 WORST EMISSIONS

Samsung Electronics										
Project : 12114206										
Date: 2-15-2012										
Config: EUT/Headset/Adapter										
Mode: TX, BT , Worst Case										
Tested by: S. Aguilar										
Line-L1 .15 - 30MHz										
Test Frequency	Meter Reading	Detector	T24 LISN [dB]	Cables [dB]	Corrected dBuV	Class B QP	QP Margin	Class B Avg	Av Margin	
0.501	46.6	PK	0.1	0	46.7	56	-9.3	-	-	
0.501	29.87	Av	0.1	0	29.97	-	-	46	-16.03	
6.594	44.58	PK	0.1	0.1	44.78	60	-15.22	-	-	
6.594	27.85	Av	0.1	0.1	28.05	-	-	50	-21.95	
25.719	44	PK	0.5	0.3	44.8	60	-15.2	-	-	
25.719	25.43	Av	0.5	0.3	26.23	-	-	50	-23.77	
Line-L2 .15 - 30MHz										
Test Frequency	Meter Reading	Detector	T24 LISN [dB]	Cables [dB]	Corrected dBuV	Class B QP	QP Margin	Class B Avg	Av Margin	
0.5145	45.78	PK	0.1	0	45.88	56	-10.12	-	-	
0.5145	24.22	Av	0.1	0	24.32	-	-	46	-21.68	
6.8145	44.65	PK	0.1	0.1	44.85	60	-15.15	-	-	
6.8145	23.53	Av	0.1	0.1	23.73	-	-	50	-26.27	
25.9665	43.43	PK	0.5	0.3	44.23	60	-15.77	-	-	
25.9665	23.98	Av	0.5	0.3	24.78	-	-	50	-25.22	
PK - Peak detector										
QP - Quasi-Peak detector										
Av - Average detector										

LINE 1 RESULTS

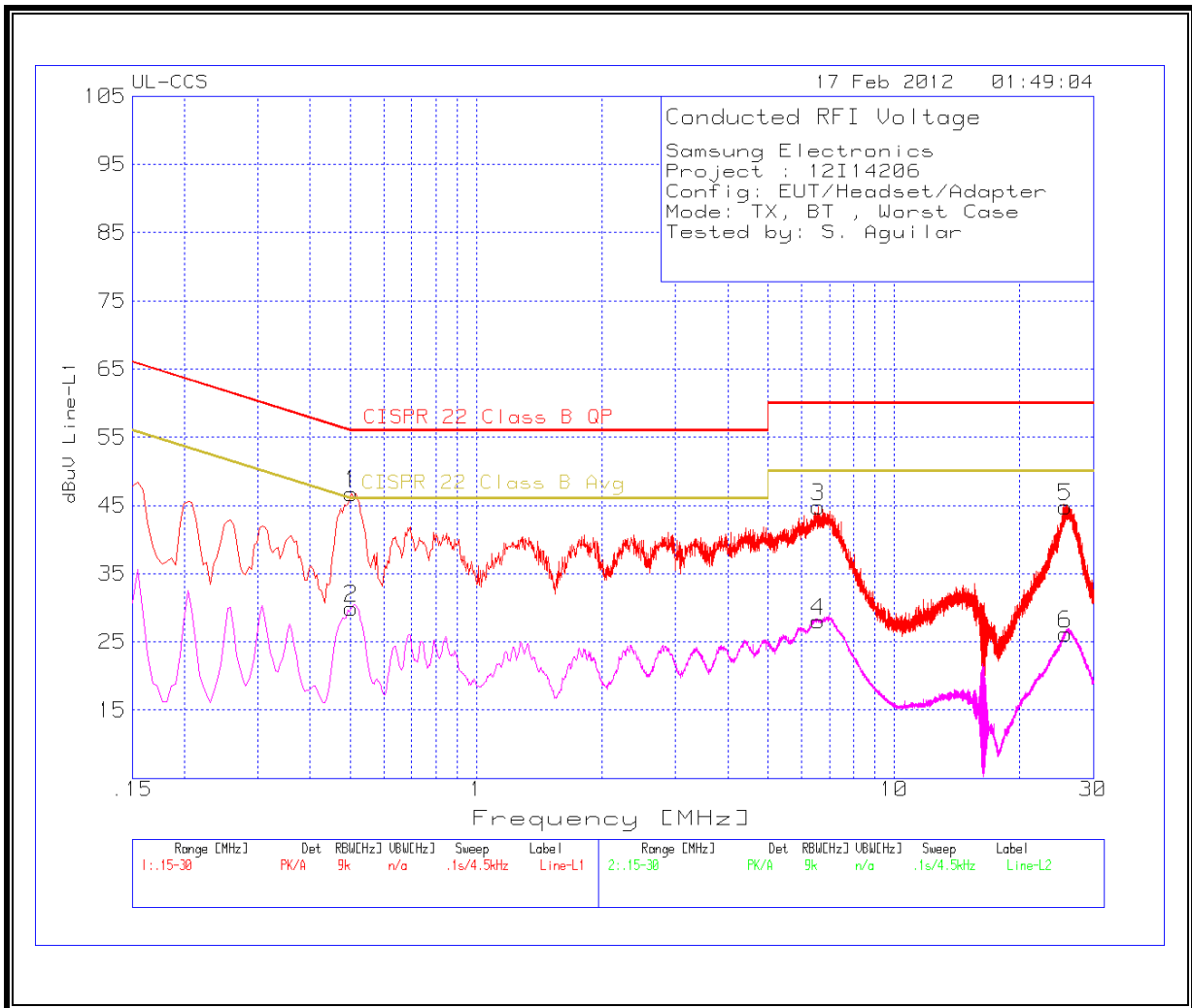

LINE 2 RESULTS

