



# PCTEST ENGINEERING LABORATORY, INC.

6660-B Dobbin Road, Columbia, MD 21045 USA  
Tel. 410.290.6652 / Fax 410.290.6554  
<http://www.pctestlab.com>



## SAR COMPLIANCE EVALUATION REPORT

**Applicant Name:**  
Samsung Electronics, Co. Ltd.  
18600 Broadwick St.  
Rancho Dominguez, CA 90220  
United States

**Date of Testing:**  
09/23/10 - 09/29/10  
**Test Site/Location:**  
PCTEST Lab, Columbia, MD, USA  
**Test Report Serial No.:**  
0Y1009221630-R1.A3L

**FCC ID:** A3LGTP1010

**APPLICANT:** SAMSUNG ELECTRONICS, CO. LTD.

**EUT Type:** Mini Tablet with WLAN and Bluetooth  
**Application Type:** Certification  
**FCC Rule Part(s):** CFR §2.1093; FCC/OET Bulletin 65 Supplement C [June 2001]  
**FCC Classification:** Digital Transmission System (DTS)  
**Model(s):** GT-P1010  
**Tx Frequency:** 2412 - 2462 MHz (IEEE 802.11 b/g/n)  
5 GHz (IEEE 802.11a/n)  
**Conducted Power:** 17.06 dBm 2.4 GHz WLAN  
12.33 dBm 5 GHz WLAN  
**Max. SAR Measurement:** 0.63 W/kg 2.4 GHz WLAN Body SAR  
0.76 W/Kg 5 GHz WLAN Body SAR  
**Test Device Serial No.:** Pre-Production [S/N: FH-218-C]



This wireless portable device has been shown to be capable of compliance for localized specific absorption rate (SAR) for uncontrolled environment/general population exposure limits specified in ANSI/IEEE C95.1-1992 and has been tested in accordance with the measurement procedures specified in FCC/OET Bulletin 65 Supplement C (2001), IEEE 1528-2003 and in applicable Industry Canada Radio Standards Specifications (RSS); for North American frequency bands only.

I attest to the accuracy of data. All measurements reported herein were performed by me or were made under my supervision and are correct to the best of my knowledge and belief. I assume full responsibility for the completeness of these measurements and vouch for the qualifications of all persons taking them. Test results reported herein relate only to the item(s) tested.

*PCTEST certifies that no party to this application has been denied the FCC benefits pursuant to Section 5301 of the Anti-Drug Abuse Act of 1988, 21 U.S.C. 862.*

  
Randy Ortanez  
President





<b>FCC ID:</b> A3LGTP1010		<b>SAR COMPLIANCE REPORT</b>		<b>Reviewed by:</b> Quality Manager
<b>Filename:</b> 0Y1009221630-R1.A3L	<b>Test Dates:</b> 09/23/10 - 09/29/10	<b>EUT Type:</b> Mini Tablet with WLAN and Bluetooth	Page 1 of 28	

# TABLE OF CONTENTS

---

1	INTRODUCTION .....	3
2	TEST SITE LOCATION .....	4
3	SAR MEASUREMENT SETUP .....	5
4	DASY E-FIELD PROBE SYSTEM .....	7
5	PROBE CALIBRATION PROCESS .....	8
6	PHANTOM AND EQUIVALENT TISSUES.....	9
7	DOSIMETRIC ASSESSMENT & PHANTOM SPECS.....	10
8	RF EXPOSURE LIMITS .....	11
9	MEASUREMENT UNCERTAINTIES .....	12
10	SYSTEM VERIFICATION.....	14
11	FCC ANTENNA SAR CONSIDERATIONS .....	16
12	WIFI MEASUREMENT PROCEDURES .....	17
13	SAR DATA SUMMARY .....	20
14	EQUIPMENT LIST.....	22
15	CONCLUSION.....	23
16	REFERENCES .....	24
17	SAR TEST SETUP PHOTOGRAPHS.....	26

<b>FCC ID:</b> A3LGTP1010		<b>SAR COMPLIANCE REPORT</b>		<b>Reviewed by:</b> Quality Manager
<b>Filename:</b> 0Y1009221630-R1.A3L	<b>Test Dates:</b> 09/23/10 - 09/29/10	<b>EUT Type:</b> Mini Tablet with WLAN and Bluetooth		Page 2 of 28

# 1 INTRODUCTION

The FCC has adopted the guidelines for evaluating the environmental effects of radio frequency (RF) radiation in ET Docket 93-62 on Aug. 6, 1996 to protect the public and workers from the potential hazards of RF emissions due to FCC-regulated portable devices.[1]

The safety limits used for the environmental evaluation measurements are based on the criteria published by the American National Standards Institute (ANSI) for localized specific absorption rate (SAR) in IEEE/ANSI C95.1-1992 Standard for Safety Levels with Respect to Human Exposure to Radio Frequency Electromagnetic Fields, 3 kHz to 300 GHz[2] and Health Canada RF Exposure Guidelines Safety Code 6 [26]. The measurement procedure described in IEEE/ANSI C95.3-2002 Recommended Practice for the Measurement of Potentially Hazardous Electromagnetic Fields - RF and Microwave [3] is used for guidance in measuring the Specific Absorption Rate (SAR) due to the RF radiation exposure from the Equipment Under Test (EUT). These criteria for SAR evaluation are similar to those recommended by the International Committee for Non-Ionizing Radiation Protection (ICNIRP) in Biological Effects and Exposure Criteria for Radiofrequency Electromagnetic Fields," Report No. Vol 74. SAR is a measure of the rate of energy absorption due to exposure to an RF transmitting source. SAR values have been related to threshold levels for potential biological hazards.

## 1.1 SAR Definition

Specific Absorption Rate is defined as the time derivative (rate) of the incremental energy (dU) absorbed by (dissipated in) an incremental mass (dm) contained in a volume element (dV) of a given density ( $\rho$ ). It is also defined as the rate of RF energy absorption per unit mass at a point in an absorbing body (see Fig. 1-1).

$$SAR = \frac{d}{dt} \left( \frac{dU}{dm} \right) = \frac{d}{dt} \left( \frac{dU}{\rho dV} \right)$$

Figure 1-1  
SAR Mathematical Equation



SAR is expressed in units of Watts per Kilogram (W/kg).

$$SAR = \frac{\sigma \cdot E^2}{\rho}$$

where:

- $\sigma$  = conductivity of the tissue-simulating material (S/m)
- $\rho$  = mass density of the tissue-simulating material ( $\text{kg/m}^3$ )
- E = Total RMS electric field strength (V/m)

NOTE: The primary factors that control rate of energy absorption were found to be the wavelength of the incident field in relation to the dimensions and geometry of the irradiated organism, the orientation of the organism in relation to the polarity of field vectors, the presence of reflecting surfaces, and whether conductive contact is made by the organism with a ground plane.[6]

FCC ID: A3LGTP1010	 PCTEST ENGINEERING LABORATORY, INC.	SAR COMPLIANCE REPORT		Reviewed by: Quality Manager
Filename: 0Y1009221630-R1.A3L	Test Dates: 09/23/10 - 09/29/10	EUT Type: Mini Tablet with WLAN and Bluetooth		Page 3 of 28

## 2 TEST SITE LOCATION

### 2.1 INTRODUCTION

The map at the right shows the location of the PCTEST LABORATORY in Columbia, Maryland. It is in proximity to the FCC Laboratory, the Baltimore-Washington International (BWI) airport, the city of Baltimore and Washington, DC (See Figure 2).

These measurement tests were conducted at the PCTEST Engineering Laboratory, Inc. facility in New Concept Business Park, Guilford Industrial Park, Columbia, Maryland. The site address is 6660-B Dobbin Road, Columbia, MD 21045. The test site is one of the highest points in the Columbia area with an elevation of 390 feet above mean sea level. The site coordinates are 39° 11'15" N latitude and 76° 49' 38" W longitude. The facility is 1.5 miles north of the FCC laboratory, and the ambient signal and ambient signal strength are approximately equal to those of the FCC laboratory. There are no FM or TV transmitters within 15 miles of the site. The detailed description of the measurement facility was found to be in compliance with the requirements of § 2.948 according to ANSI C63.4 on January 27, 2006 and Industry Canada.

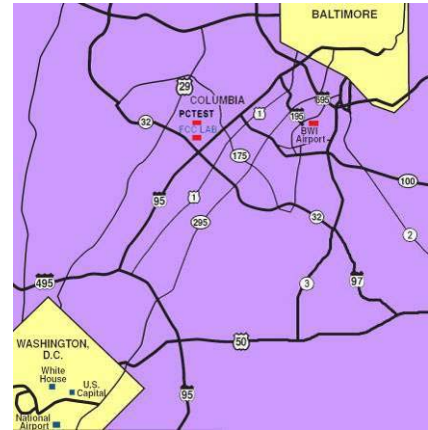

**Figure 2-1**  
Map of the Greater Baltimore and Metropolitan Washington, D.C. area

### 2.2 Test Facility / Accreditations:

Measurements were performed at an independent accredited PCTEST Engineering Lab located in Columbia, MD 21045, U.S.A.



- PCTEST Lab is accredited to ISO 17025-2005 by the American Association for Laboratory Accreditation (A2LA) in Specific Absorption Rate (SAR) testing, Hearing-Aid Compatibility (HAC), CTIA Test Plans, and wireless testing for FCC and Industry Canada Rules.
- PCTEST Lab is accredited to ISO 17025 by U.S. National Institute of Standards and Technology (NIST) under the National Voluntary Laboratory Accreditation Program (NVLAP Lab code: 100431-0) in EMC, FCC and Telecommunications.
- PCTEST facility is an FCC registered (PCTEST Reg. No. 90864) test facility with the site description report on file and has met all the requirements specified in Section 2.948 of the FCC Rules and Industry Canada (IC-2451).
- PCTEST Lab is a recognized U.S. Conformity Assessment Body (CAB) in EMC and R&TTE (n.b. 0982) under the U.S.-EU Mutual Recognition Agreement (MRA).
- PCTEST TCB is a Telecommunication Certification Body (TCB) accredited to ISO/IEC Guide 65 by the American National Standards Institute (ANSI) in all scopes of FCC Rules and all Industry Canada Standards (RSS).
- PCTEST facility is an IC registered (IC-2451) test laboratory with the site description on file at Industry Canada.
- PCTEST is a CTIA Authorized Test Laboratory (CATL) for AMPS and CDMA, and EvDO mobile phones.
- PCTEST is a CTIA Authorized Test Laboratory (CATL) for Over-the-Air (OTA) Antenna Performance testing for AMPS, CDMA, GSM, GPRS, EGPRS, UMTS (W-CDMA), CDMA 1xEVDO Data, CDMA 1xRTT Data

FCC ID: A3LGTP1010	PCTEST ENGINEERING LABORATORY, INC.	SAR COMPLIANCE REPORT	SAMSUNG	Reviewed by: Quality Manager
Filename: 0Y1009221630-R1.A3L	Test Dates: 09/23/10 - 09/29/10	EUT Type: Mini Tablet with WLAN and Bluetooth	Page 4 of 28	

## 3 SAR MEASUREMENT SETUP

### 3.1 Robotic System

Measurements are performed using the DASY4 automated dosimetric assessment system. The DASY4 is made by Schmid & Partner Engineering AG (SPEAG) in Zurich, Switzerland and consists of a high precision robotics system (Staubli), robot controller, desktop computer, near-field probe, probe alignment sensor, and the SAM phantom containing the head or body equivalent material. The robot is a six-axis industrial robot, performing precise movements to position the probe to the location (points) of maximum electromagnetic field (EMF) (see Figure 3-1).

### 3.1 System Hardware

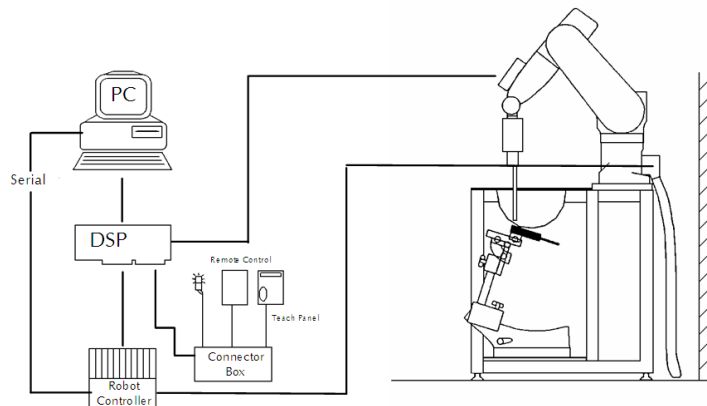

A cell controller system contains the power supply, robot controller, teach pendant (Joystick), and a remote control used to drive the robot motors. The PC consists of the SAR Measurement Software DASY4, A/D interface card, monitor, mouse, and keyboard. The Staubli Robot is connected to the cell controller to allow software manipulation of the robot. A data acquisition electronic (DAE) circuit that performs the signal amplification, signal multiplexing, A/D conversion, offset measurements, mechanical surface detection, collision detection, etc. is connected to the Electro-optical coupler (EOC). The EOC performs the conversion from the optical into digital electric signal from the DAE and transfers data to the PC card.

### 3.2 System Electronics



**Figure 3-1**  
**SAR Measurement System Setup**

The DAE consists of a highly sensitive electrometer-grade auto-zeroing preamplifier, a channel and gain-switching multiplexer, a fast 16 bit AD-converter and a command decoder and control logic unit. Transmission to the PC-card is accomplished through an optical downlink for data and status information and an optical uplink for commands and clock lines. The mechanical probe mounting device includes two different sensor systems for frontal and sidewise probe contacts. They are also used for mechanical surface detection and probe collision detection. The robot uses its own controller with a built in VME-bus computer.

FCC ID: A3LGTP1010	 PCTEST ENGINEERING LABORATORY, INC.	SAR COMPLIANCE REPORT		Reviewed by: Quality Manager
Filename: 0Y1009221630-R1.A3L	Test Dates: 09/23/10 - 09/29/10	EUT Type: Mini Tablet with WLAN and Bluetooth		Page 5 of 28



### 4.1 Probe Measurement System



Figure 4-1  
SAR System

The SAR measurements were conducted with the dosimetric probe designed in the classical triangular configuration [7] (see Figure 4-3) and optimized for dosimetric evaluation. The probe is constructed using the thick film technique; with printed resistive lines on ceramic substrates. The probe is equipped with an optical multi-fiber line ending at the front of the probe tip. It is connected to the EOC box on the robot arm and provides an automatic detection of the phantom surface. Half of the fibers are connected to a pulsed infrared transmitter, the other half to a synchronized receiver. As the probe approaches the surface, the reflection from the surface produces a coupling from the transmitting to the receiving fibers. This reflection increases first during the approach, reaches maximum and then decreases. If the probe is flatly touching the surface, the coupling is zero. The distance of the coupling maximum to the surface is independent of the surface reflectivity and largely independent of the surface to probe angle. The DASY4 software reads the reflection during a software approach and looks for the

maximum using a 2nd order curve fitting (see Figure 5-1). The approach is stopped at reaching the maximum.

### 4.1 Probe Specifications



<b>Model:</b>	ES3DV3, EX3DV4
<b>Frequency Range:</b>	10 MHz – 6.0 GHz (EX3DV4) 10 MHz – 4 GHz (ES3DV3)
<b>Calibration:</b>	In head and body simulating tissue at Frequencies from 835 up to 5800MHz
<b>Linearity:</b>	± 0.2 dB (30 MHz to 6 GHz) for EX3DV4 ± 0.2 dB (30 MHz to 4 GHz) for ES3DV3
<b>Dynamic Range:</b>	10 mW/kg – 100 W/kg
<b>Probe Length:</b>	330 mm
<b>Probe Tip Length:</b>	20 mm
<b>Body Diameter:</b>	12 mm
<b>Tip Diameter:</b>	2.5 mm (3.9mm for ES3DV3)
<b>Tip-Center:</b>	1 mm (2.0 mm for ES3DV3)
<b>Application:</b>	SAR Dosimetry Testing Compliance tests of mobile phones Dosimetry in strong gradient fields



Figure 4-2  
Near-Field Probe



Figure 4-3  
Triangular Probe Configuration

FCC ID: A3LGTP1010	 PCTEST ENGINEERING LABORATORY, INC.	SAR COMPLIANCE REPORT		Reviewed by: Quality Manager
Filename: OY1009221630-R1.A3L	Test Dates: 09/23/10 - 09/29/10	EUT Type: Mini Tablet with WLAN and Bluetooth		Page 7 of 28

# 5 PROBE CALIBRATION PROCESS

## 5.1 Dosimetric Assessment Procedure

Each E-Probe/Probe Amplifier combination has unique calibration parameters. A TEM cell calibration procedure is conducted to determine the proper amplifier settings to enter in the probe parameters. The amplifier settings are determined for a given frequency by subjecting the probe to a known E-field density (1 mW/cm<sup>2</sup>) using an RF Signal generator, TEM cell, and RF Power Meter.

## 5.2 Free Space Assessment

The free space E-field from amplified probe outputs is determined in a test chamber. This calibration can be performed in a TEM cell if the frequency is below 1 GHz and in a waveguide or other methodologies above 1 GHz for free space. For the free space calibration, the probe is placed in the volumetric center of the cavity and at the proper orientation with the field. The probe is rotated 360 degrees until the three channels show the maximum reading. The power density readings equates to 1 mW/cm<sup>2</sup>.

## 5.3 Temperature Assessment

E-field temperature correlation calibration is performed in a flat phantom filled with the appropriate simulated head tissue. The E-field in the medium correlates with the temperature rise in the dielectric medium. For temperature correlation calibration a RF transparent thermistor-based temperature probe is used in conjunction with the E-field probe.

$$SAR = C \frac{\Delta T}{\Delta t}$$

where:

- $\Delta t$  = exposure time (30 seconds),
- C = heat capacity of tissue (brain or muscle),
- $\Delta T$  = temperature increase due to RF exposure.

$$SAR = \frac{|E|^2 \cdot \sigma}{\rho}$$

where:

- $\sigma$  = simulated tissue conductivity,
- $\rho$  = Tissue density (1.25 g/cm<sup>3</sup> for brain tissue)

SAR is proportional to  $\Delta T/\Delta t$ , the initial rate of tissue heating, before thermal diffusion takes place. The electric field in the simulated tissue can be used to estimate SAR by equating the thermally derived SAR to that with the E- field component.



Figure 5-1 E-Field and Temperature measurements at 900MHz [7]



Figure 5-2 E-Field and temperature measurements at 1.9GHz [7]

FCC ID: A3LGTP1010	PCTEST ENGINEERING LABORATORY, INC.	SAR COMPLIANCE REPORT		Reviewed by: Quality Manager
Filename: 0Y1009221630-R1.A3L	Test Dates: 09/23/10 - 09/29/10	EUT Type: Mini Tablet with WLAN and Bluetooth		Page 8 of 28

# 6

## PHANTOM AND EQUIVALENT TISSUES

### 6.1 SAM Phantoms



**Figure 6-1  
SAM Phantoms**

The SAM Twin Phantom V4.0 is constructed of a fiberglass shell integrated in a table. The shape of the shell is based on data from an anatomical study designed to represent the 90<sup>th</sup> percentile of the population [11][12]. The phantom enables the dosimetric evaluation of SAR for both left and right handed handset usage, as well as body-worn usage using the flat phantom region. Reference markings on the Phantom allow the complete setup of all predefined phantom positions and measurement grids by manually teaching three points in the robot. The shell phantom has a 2mm shell thickness (except the ear region where shell thickness increases to 6 mm).

### 6.2 Head & Body Simulating Mixture Characterization





**Figure 6-2  
SAM Phantom with  
Simulating Tissue**

The mixture is characterized to obtain proper dielectric constant (permittivity) and conductivity of the tissue of interest. The head tissue dielectric parameters recommended in IEEE 1528 and IEC 62209 have been used as targets for the compositions, and are to match within 5%, per the FCC recommendations.

**Table 6-1**  
Composition of the Head & Body Tissue Equivalent Matter

Frequency (MHz)	2450	5200-5800
Tissue	Body	Body
Ingredients (% by weight)		
DGBE	26.7	
DEGEE		10.67
NaCl	0.1	
Triton X-100		10.67
Water	73.2	78.67

FCC ID: A3LGTP1010	 PCTEST ENGINEERING LABORATORY, INC.	SAR COMPLIANCE REPORT		Reviewed by: Quality Manager
Filename: 0Y1009221630-R1.A3L	Test Dates: 09/23/10 - 09/29/10	EUT Type: Mini Tablet with WLAN and Bluetooth		Page 9 of 28

### 7.1 Measurement Procedure

The evaluation was performed using the following procedure:

1. The SAR distribution at the exposed side of the head was measured at a distance of 3.0mm from the inner surface of the shell. The area covered the entire dimension of the head and the horizontal grid spacing was 15mm x 15mm.
2. The point SAR measurement was taken at the maximum SAR region determined from Step 1 to enable the monitoring of SAR fluctuations/drifts during testing the 1 gram cube. This fixed point was measured and used as a reference value.
3. Based on the area scan data, the area of the maximum absorption was determined by spline interpolation. Around this point, a volume of 32mm x 32mm x 30mm (fine resolution volume scan, zoom scan) was assessed by measuring 5 x 5 x 7 points. On this basis of this data set, the spatial peak SAR value was evaluated with the following procedure (see references or the DASY manual for more details):
  - a. The data was extrapolated to the surface of the outer-shell of the phantom. The combined distance extrapolated was the combined distance from the center of the dipoles 2.7mm away from the tip of the probe housing plus the 1.2 mm distance between the surface and the lowest measuring point. The extrapolation was based on a least-squares algorithm. A polynomial of the fourth order was calculated through the points in the z-axis (normal to the phantom shell).
  - b. After the maximum interpolated values were calculated between the points in the cube, the SAR was averaged over the spatial volume (1g or 10g) using a 3D-Spline interpolation algorithm. The 3D-spline is composed of three one-dimensional splines with the "Not a knot" condition (in x, y, and z directions). The volume was then integrated with the trapezoidal algorithm. One thousand points (10 x 10 x 10) were obtained through interpolation, in order to calculate the averaged SAR.
  - c. All neighboring volumes were evaluated until no neighboring volume with a higher average value was found.
4. The SAR reference value, at the same location as step 2, was re-measured after the zoom scan was complete. If the value deviated by more than 5%, the evaluation was repeated.
5. For 5 GHz testing finer resolution zoom scans were performed as specified by IEC62209-1 6.3 Table 3. A frequency of 5.2 GHz requires a minimum volume of 23mm x 23mm x 22.4mm assessed by measuring 6 x 6 x 9 points. A frequency of 5.5 GHz requires a minimum volume of 22mm x 22mm x 22.5mm and 6 x 6 x 10. Finally, a frequency of 5.8 GHz requires a minimum volume of 24mm x 24mm x 22mm and 7 x 7 x 11 points.

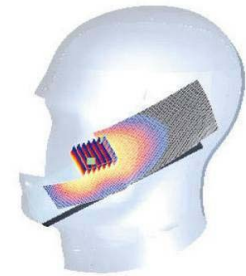



**Figure 7-1**  
**Sample SAR Area Scan**

### 7.2 Specific Anthropomorphic Mannequin (SAM) Specifications

The phantom for handset SAR assessment testing is a low-loss dielectric shell, with shape and dimensions derived from the anthropometric data of the 90th percentile adult male head dimensions as tabulated by the US Army. The SAM Twin Phantom shell is bisected along the mid-sagittal plane into right and left halves (see Figure 7-2). The perimeter sidewalls of each phantom halves are extended to allow filling with liquid to a depth that is sufficient to minimize reflections from the upper surface. The liquid depth is maintained at a minimum depth of 15 cm.



**Figure 7-2**  
**SAM Twin Phantom Shell**

FCC ID: A3LGTP1010		SAR COMPLIANCE REPORT		Reviewed by: Quality Manager
Filename: OY1009221630-R1.A3L	Test Dates: 09/23/10 - 09/29/10	EUT Type: Mini Tablet with WLAN and Bluetooth		Page 10 of 28

### 8.1 Uncontrolled Environment

UNCONTROLLED ENVIRONMENTS are defined as locations where there is the exposure of individuals who have no knowledge or control of their exposure. The general population/uncontrolled exposure limits are applicable to situations in which the general public may be exposed or in which persons who are exposed as a consequence of their employment may not be made fully aware of the potential for exposure or cannot exercise control over their exposure. Members of the general public would come under this category when exposure is not employment-related; for example, in the case of a wireless transmitter that exposes persons in its vicinity.

### 8.1 Controlled Environment

CONTROLLED ENVIRONMENTS are defined as locations where there is exposure that may be incurred by persons who are aware of the potential for exposure, (i.e. as a result of employment or occupation). In general, occupational/controlled exposure limits are applicable to situations in which persons are exposed as a consequence of their employment, who have been made fully aware of the potential for exposure and can exercise control over their exposure. This exposure category is also applicable when the exposure is of a transient nature due to incidental passage through a location where the exposure levels may be higher than the general population/uncontrolled limits, but the exposed person is fully aware of the potential for exposure and can exercise control over his or her exposure by leaving the area or by some other appropriate means.



**Table 8-1**  
**SAR Human Exposure Specified in ANSI/IEEE C95.1-1992 and Health Canada Safety Code 6**

HUMAN EXPOSURE LIMITS		
	UNCONTROLLED ENVIRONMENT <i>General Population</i> (W/kg) or (mW/g)	CONTROLLED ENVIRONMENT <i>Occupational</i> (W/kg) or (mW/g)
SPATIAL PEAK SAR Brain	1.6	8.0
SPATIAL AVERAGE SAR Whole Body	0.08	0.4
SPATIAL PEAK SAR Hands, Feet, Ankles, Wrists	4.0	20

The Spatial Peak value of the SAR averaged over any 1 gram of tissue (defined as a tissue volume in the shape of a cube) and over the appropriate averaging time.

2 The Spatial Average value of the SAR averaged over the whole body.

3 The Spatial Peak value of the SAR averaged over any 10 grams of tissue (defined as a tissue volume in the shape of a cube) and over the appropriate averaging time.

FCC ID: A3LGTP1010	 PCTEST ENGINEERING LABORATORY, INC.	SAR COMPLIANCE REPORT		Reviewed by: Quality Manager
Filename: 0Y1009221630-R1.A3L	Test Dates: 09/23/10 - 09/29/10	EUT Type: Mini Tablet with WLAN and Bluetooth		Page 11 of 28



## 9

## MEASUREMENT UNCERTAINTIES

Applicable for 800 - 3000 MHz.

a	b	c	d	e= f(d,k)	f	g	h = c x f/e	i = c x g/e	k
Uncertainty Component	IEEE 1528 Sec.	Tol. (± %)	Prob. Dist.	Div.	c <sub>i</sub> 1gm	c <sub>i</sub> 10 gms	1gm u <sub>i</sub> (± %)	10gms u <sub>i</sub> (± %)	v <sub>i</sub>
<b>Measurement System</b>									
Probe Calibration	E.2.1	5.5	N	1	1.0	1.0	5.5	5.5	∞
Axial Isotropy	E.2.2	0.25	N	1	0.7	0.7	0.2	0.2	∞
Hemishperical Isotropy	E.2.2	1.3	N	1	1.0	1.0	1.3	1.3	∞
Boundary Effect	E.2.3	0.4	N	1	1.0	1.0	0.4	0.4	∞
Linearity	E.2.4	0.3	N	1	1.0	1.0	0.3	0.3	∞
System Detection Limits	E.2.5	5.1	N	1	1.0	1.0	5.1	5.1	∞
Readout Electronics	E.2.6	1.0	N	1	1.0	1.0	1.0	1.0	∞
Response Time	E.2.7	0.8	R	1.73	1.0	1.0	0.5	0.5	∞
Integration Time	E.2.8	2.6	R	1.73	1.0	1.0	1.5	1.5	∞
RF Ambient Conditions	E.6.1	3.0	R	1.73	1.0	1.0	1.7	1.7	∞
Probe Positioner Mechanical Tolerance	E.6.2	0.4	R	1.73	1.0	1.0	0.2	0.2	∞
Probe Positioning w/ respect to Phantom	E.6.3	2.9	R	1.73	1.0	1.0	1.7	1.7	∞
Extrapolation, Interpolation & Integration algorithms for Max. SAR Evaluation	E.5	1.0	R	1.73	1.0	1.0	0.6	0.6	∞
<b>Test Sample Related</b>									
Test Sample Positioning	E.4.2	6.0	N	1	1.0	1.0	6.0	6.0	287
Device Holder Uncertainty	E.4.1	3.32	R	1.73	1.0	1.0	1.9	1.9	∞
Output Power Variation - SAR drift measurement	6.6.2	5.0	R	1.73	1.0	1.0	2.9	2.9	∞
<b>Phantom &amp; Tissue Parameters</b>									
Phantom Uncertainty (Shape & Thickness tolerances)	E.3.1	4.0	R	1.73	1.0	1.0	2.3	2.3	∞
Liquid Conductivity - deviation from target values	E.3.2	5.0	R	1.73	0.64	0.43	1.8	1.2	∞
Liquid Conductivity - measurement uncertainty	E.3.3	3.8	N	1	0.64	0.43	2.4	1.6	6
Liquid Permittivity - deviation from target values	E.3.2	5.0	R	1.73	0.60	0.49	1.7	1.4	∞
Liquid Permittivity - measurement uncertainty	E.3.3	4.5	N	1	0.60	0.49	2.7	2.2	6
<b>Combined Standard Uncertainty (k=1)</b>				RSS			11.8	11.5	299
<b>Expanded Uncertainty</b> (95% CONFIDENCE LEVEL)				k=2			23.7	23.0	



The above measurement uncertainties are according to IEEE Std. 1528-2003

FCC ID: A3LGTP1010	 PCTEST ENGINEERING LABORATORY, INC.	SAR COMPLIANCE REPORT		Reviewed by: Quality Manager
Filename: 0Y1009221630-R1.A3L	Test Dates: 09/23/10 - 09/29/10	EUT Type: Mini Tablet with WLAN and Bluetooth		Page 12 of 28

Applicable for 5 GHz.

a	b	c	d	e= f(d,k)	f	g	h = c x f/e	i = c x g/e	k	
Uncertainty Component	IEEE 1528 Sec.	Tol. (± %)	Prob. Dist.	Div.	c <sub>i</sub> 1gm	c <sub>i</sub> 10 gms	1gm u <sub>i</sub> (± %)	10gms u <sub>i</sub> (± %)	v <sub>i</sub>	
<b>Measurement System</b>										
Probe Calibration	E.2.1	6.6	N	1	1.0	1.0	6.6	6.6	∞	
Axial Isotropy	E.2.2	0.25	N	1	0.7	0.7	0.2	0.2	∞	
Hemishperical Isotropy	E.2.2	1.3	N	1	1.0	1.0	1.3	1.3	∞	
Boundary Effect	E.2.3	0.4	N	1	1.0	1.0	0.4	0.4	∞	
Linearity	E.2.4	0.3	N	1	1.0	1.0	0.3	0.3	∞	
System Detection Limits	E.2.5	5.1	N	1	1.0	1.0	5.1	5.1	∞	
Readout Electronics	E.2.6	1.0	N	1	1.0	1.0	1.0	1.0	∞	
Response Time	E.2.7	0.8	R	1.73	1.0	1.0	0.5	0.5	∞	
Integration Time	E.2.8	2.6	R	1.73	1.0	1.0	1.5	1.5	∞	
RF Ambient Conditions	E.6.1	3.0	R	1.73	1.0	1.0	1.7	1.7	∞	
Probe Positioner Mechanical Tolerance	E.6.2	0.4	R	1.73	1.0	1.0	0.2	0.2	∞	
Probe Positioning w/ respect to Phantom	E.6.3	2.9	R	1.73	1.0	1.0	1.7	1.7	∞	
Extrapolation, Interpolation & Integration algorithms for Max. SAR Evaluation	E.5	1.0	R	1.73	1.0	1.0	0.6	0.6	∞	
<b>Test Sample Related</b>										
Test Sample Positioning	E.4.2	6.0	N	1	1.0	1.0	6.0	6.0	287	
Device Holder Uncertainty	E.4.1	3.32	R	1.73	1.0	1.0	1.9	1.9	∞	
Output Power Variation - SAR drift measurement	6.6.2	5.0	R	1.73	1.0	1.0	2.9	2.9	∞	
<b>Phantom &amp; Tissue Parameters</b>										
Phantom Uncertainty (Shape & Thickness tolerances)	E.3.1	4.0	R	1.73	1.0	1.0	2.3	2.3	∞	
Liquid Conductivity - deviation from target values	E.3.2	5.0	R	1.73	0.64	0.43	1.8	1.2	∞	
Liquid Conductivity - measurement uncertainty	E.3.3	3.8	N	1	0.64	0.43	2.4	1.6	6	
Liquid Permittivity - deviation from target values	E.3.2	5.0	R	1.73	0.60	0.49	1.7	1.4	∞	
Liquid Permittivity - measurement uncertainty	E.3.3	4.5	N	1	0.60	0.49	2.7	2.2	6	
<b>Combined Standard Uncertainty (k=1)</b>							RSS	12.4	12.0	299
<b>Expanded Uncertainty</b> (95% CONFIDENCE LEVEL)							k=2	24.7	24.0	

The above measurement uncertainties are according to IEEE Std. 1528-2003

FCC ID: A3LGTP1010	 PCTEST ENGINEERING LABORATORY, INC.	SAR COMPLIANCE REPORT		Reviewed by: Quality Manager
Filename: 0Y1009221630-R1.A3L	Test Dates: 09/23/10 - 09/29/10	EUT Type: Mini Tablet with WLAN and Bluetooth		Page 13 of 28

# 10 SYSTEM VERIFICATION

## 10.1 Tissue Verification

**Table 10-1  
Measured Tissue Properties**

Calibrated for Tests Performed	Tissue Type	Measured Frequency (MHz)	Measured Conductivity, $\sigma$ (S/m)	Measured Dielectric Constant, $\epsilon$	TARGET Conductivity, $\sigma$ (S/m)	TARGET Dielectric Constant, $\epsilon$	% dev $\sigma$	% dev $\epsilon$
09/23/2010	2450B	2401	1.860	50.88	1.90	52.77	-2.26%	-3.57%
		2450	1.926	50.77	1.95	52.70	-1.23%	-3.66%
		2499	2.005	50.63	2.02	52.64	-0.69%	-3.81%
9/28/2010 to 9/29/2010	5200-5800B	5170	5.130	47.12	5.26	49.06	-2.55%	-3.94%
		5210	5.181	47.06	5.31	49.00	-2.45%	-3.96%
		5250	5.250	46.98	5.36	48.95	-2.02%	-4.02%
		5270	5.273	46.91	5.38	48.92	-2.01%	-4.11%
		5310	5.316	46.85	5.43	48.87	-2.06%	-4.12%
		5350	5.386	46.77	5.47	48.81	-1.54%	-4.18%
		5470	5.537	46.51	5.62	48.65	-1.39%	-4.39%
		5510	5.587	46.47	5.66	48.59	-1.31%	-4.37%
		5550	5.655	46.39	5.71	48.54	-0.93%	-4.43%
		5570	5.675	46.34	5.73	48.51	-0.98%	-4.48%
		5610	5.725	46.24	5.78	48.46	-0.92%	-4.58%
		5650	5.785	46.24	5.83	48.40	-0.69%	-4.47%
		5670	5.812	46.16	5.85	48.38	-0.62%	-4.58%
		5710	5.862	46.04	5.90	48.32	-0.56%	-4.72%
		5750	5.929	45.99	5.94	48.27	-0.22%	-4.72%
		5770	5.956	45.95	5.97	48.24	-0.15%	-4.75%
		5810	5.994	45.87	6.01	48.19	-0.30%	-4.81%
5850	6.061	45.77	6.06	48.13	0.05%	-4.91%		

Note: KDB Publication 450824 was ensured to be applied for probe calibration frequencies greater than or equal to 50 MHz of the DUT frequencies.



The above measured tissue parameters were used in the DASY software to perform interpolation via the DASY software to determine actual dielectric parameters at the test frequencies (per IEEE 1528 6.6.1.2). The SAR test plots may slightly differ from the table above since the DASY software rounds to three significant digits.

## 10.2 Measurement Procedure for Tissue verification

- 1) The network analyzer and probe system was configured and calibrated.
- 2) The probe was immersed in the sample which was placed in a nonmetallic container. Trapped air bubbles beneath the flange were minimized by placing the probe at a slight angle.
- 3) The complex admittance with respect to the probe aperture was measured
- 4) The complex relative permittivity, for example from the below equation (Pournaropoulos and Misra):

$$Y = \frac{j2\omega\epsilon_r\epsilon_0}{[\ln(b/a)]^2} \int_a^b \int_a^b \int_0^\pi \cos\phi' \frac{\exp[-j\omega r(\mu_0\epsilon_r\epsilon_0)^{1/2}]}{r} d\phi' d\rho' d\rho$$

where Y is the admittance of the probe in contact with the sample, the primed and unprimed coordinates refer to source and observation points, respectively,  $r^2 = \rho^2 + \rho'^2 - 2\rho\rho' \cos\phi'$ ,  $\omega$  is the angular frequency, and  $j = \sqrt{-1}$ .

FCC ID: A3LGTP1010	 PCTEST ENGINEERING LABORATORY, INC.	SAR COMPLIANCE REPORT		Reviewed by: Quality Manager
Filename: OY1009221630-R1.A3L	Test Dates: 09/23/10 - 09/29/10	EUT Type: Mini Tablet with WLAN and Bluetooth		Page 14 of 28

### 10.3 Justification for Extended SAR Dipole Calibrations

Usage of SAR dipoles calibrated less than 2 years ago but more than 1 year ago were confirmed in maintaining return loss (< - 20 dB, within 20% of prior calibration) and impedance (within 5 ohm from prior calibration) requirements per extended calibrations in KDB Publication 450824

D2450V2 SN: 719				
Date of Measurement	Return Loss (dB)	Δ %	Impedance (Ω)	ΔΩ
8/27/2009	-28.6		53.4	
8/19/2010	-27.5	-3.8%	51	-2.4

D5GHzV2 SN: 1007 5500MHz				
Date of Measurement	Return Loss (dB)	Δ %	Impedance (Ω)	ΔΩ
8/19/2009	-35.2		49.7	
8/19/2010	-31.5	-10.5%	48.4	-1.3

### 10.4 Test System Verification

Prior to assessment, the system is verified to ±10% of the manufacturer SAR measurement on the reference dipole at the time of calibration.

**Table 10-2**  
**System Verification Results**

System Verification TARGET & MEASURED										
Date:	Amb. Temp (°C)	Liquid Temp (°C)	Input Power (W)	Tissue Frequency (MHz)	Dipole SN	Tissue Type	Measured SAR <sub>1g</sub> (W/kg)	1 W Target SAR <sub>1g</sub> (W/kg)	1 W Normalized SAR <sub>1g</sub> (W/kg)	Deviation (%)
09/23/2010	24.7	23.3	0.025	2450	719	Body	1.27	51.400	50.80	-1.17%
09/28/2010	24.3	22.4	0.025	5200	1007	Body	1.87	78.900	74.80	-5.20%
09/29/2010	24.5	22.6	0.025	5500	1007	Body	2.16	84.100	86.40	2.73%
09/29/2010	24.6	22.7	0.025	5800	1007	Body	1.89	72.304	75.60	4.56%

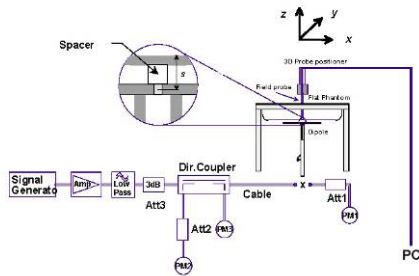

**Figure 10-1**  
**System Verification Setup Diagram**



**Figure 10-2**  
**System Verification Setup Photo**

FCC ID: A3LGTP1010	PCTEST ENGINEERING LABORATORY, INC.	SAR COMPLIANCE REPORT		Reviewed by: Quality Manager
Filename: 0Y1009221630-R1.A3L	Test Dates: 09/23/10 - 09/29/10	EUT Type: Mini Tablet with WLAN and Bluetooth		Page 15 of 28

# 11 FCC ANTENNA SAR CONSIDERATIONS

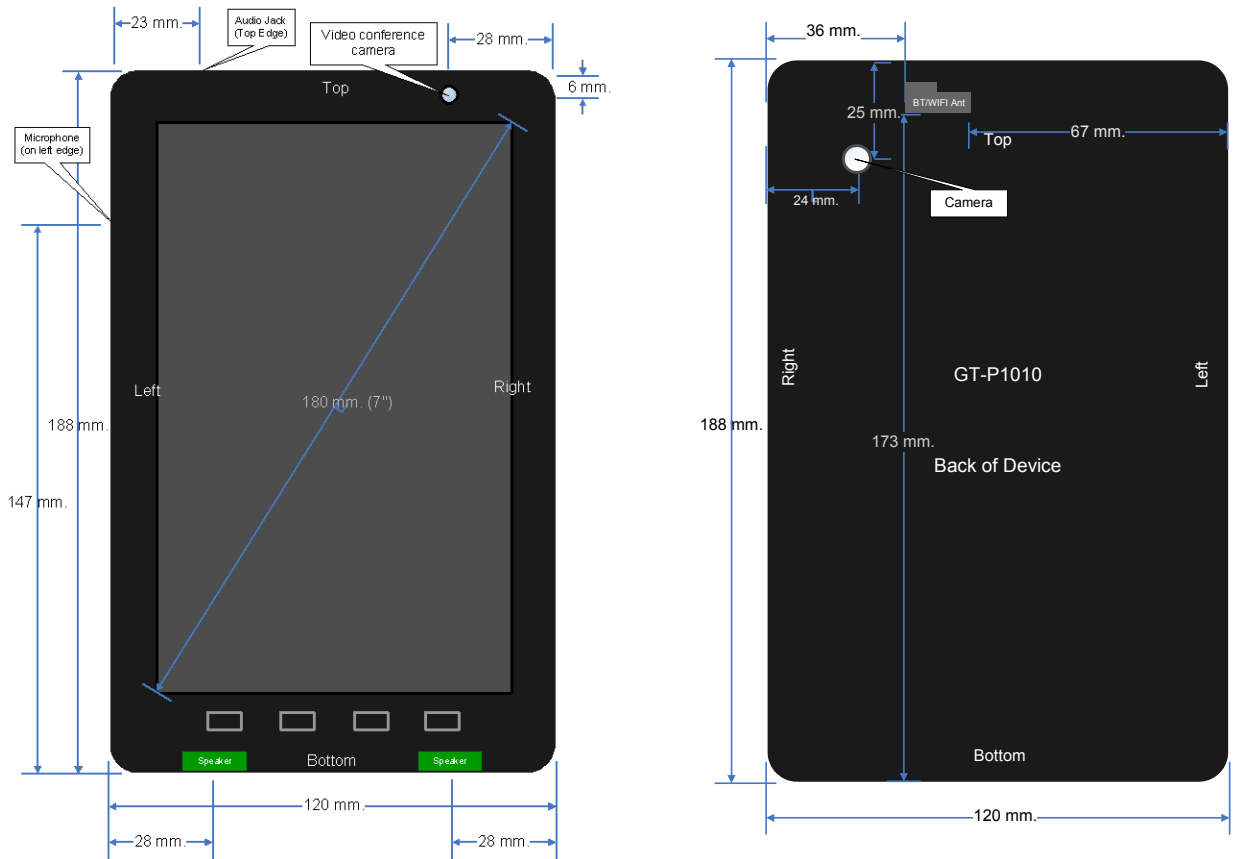

## 11.1 Mini-Tablet Edge Testing for SAR

A general composite test separation distance of 5 mm was considered for the transmitting modes of the device according to KDB Inquiry 502978. The test considerations were based on the form factor, size, operational configurations, exposure conditions, videoconference camera location, and display orientations pertinent for the device.

**Table 11-1 Display Orientation Capabilities**

Transmission Modes	Right Side Up Portrait	Up-Side Down Portrait	Left Side down Landscape	Right Side Down Landscape	Back Flat
	Bottom	Top	Left	Right	Back
Voice	Yes	Yes	Yes	Yes	Yes
Video-Call	Yes	N/A	Yes	Yes	Yes
Data Transmit Modes	Yes	Yes	Yes	Yes	Yes

## 11.2 WIFI Test Configurations

From the discussions with FCC lab pertinent to KDB Inquiry 502978, SAR was evaluated at 5 mm from the back, right and top edges. Since the antenna is closest to the back, right and top edges of the device, these edges were tested for SAR. Left and bottom edges were excluded from additional SAR testing.

FCC ID: A3LGTP1010		SAR COMPLIANCE REPORT		Reviewed by: Quality Manager
Filename: 0Y1009221630-R1.A3L	Test Dates: 09/23/10 - 09/29/10	EUT Type: Mini Tablet with WLAN and Bluetooth		Page 16 of 28

# 12 WIFI MEASUREMENT PROCEDURES

## 12.1 SAR Testing with IEEE 802.11 a/b/g Transmitters (if applicable)

Normal network operating configurations are not suitable for measuring the SAR of 802.11 a/b/g transmitters. Unpredictable fluctuations in network traffic and antenna diversity conditions can introduce undesirable variations in SAR results. The SAR for these devices should be measured using chipset based test mode software to ensure the results are consistent and reliable.

### 12.1.1 General Device Setup

Chipset based test mode software is hardware dependent and generally varies among manufacturers. The device operating parameters established in test mode for SAR measurements must be identical to those programmed in production units, including output power levels, amplifier gain settings and other RF performance tuning parameters. The test frequencies should correspond to actual channel frequencies defined for domestic use. SAR for devices with switched diversity should be measured with only one antenna transmitting at a time during each SAR measurement, according to a fixed modulation and data rate. The same data pattern should be used for all measurements.



### 12.1.2 Frequency Channel Configurations<sup>22</sup>

802.11 a/b/g and 4.9 GHz operating modes are tested independently according to the service requirements in each frequency band. 802.11 b/g modes are tested on channels 1, 6 and 11. 802.11a is tested for UNII operations on channels 36 and 48 in the 5.15-5.25 GHz band; channels 52 and 64 in the 5.25-5.35 GHz band; channels 104, 116, 124 and 136 in the 5.470-5.725 GHz band; and channels 149 and 161 in the 5.8 GHz band. When 5.8 GHz §15.247 is also available, channels 149, 157 and 165 should be tested instead of the UNII channels. 4.9 GHz is tested on channels 1, 10 and 5 or 6, whichever has the higher output power, for 5 MHz channels; channels 11, 15 and 19 for 10 MHz channels; and channels 21 and 25 for 20 MHz channels. These are referred to as the “default test channels”. 802.11g mode was evaluated only if the output power was 0.25 dB higher than the 802.11b mode.

**Table 12-1  
802.11 Test Channels per FCC Requirements**

Mode	GHz	Channel	Turbo Channel	“Default Test Channels”		UNII	
				§15.247	UNII		
				802.11b	802.11g		
802.11 b/g	2.412	1		√	∇		
	2.437	6	6	√	∇		
	2.462	11		√	∇		
802.11a	5.18	36				√	*
	5.20	40	42 (5.21 GHz)				*
	5.22	44					*
	5.24	48	50 (5.25 GHz)			√	*
	5.26	52				√	*
	5.28	56	58 (5.29 GHz)				*
	5.30	60					*
	5.32	64				√	*
	5.500	100	Unknown				*
	5.520	104				√	*
	5.540	108					*
	5.560	112					*
	5.580	116				√	*
	5.600	120					*
	5.620	124				√	*
	5.640	128					*
	5.660	132				*	
	5.680	136				√	*
	5.700	140					*
	UNII	5.745	149		√		√
§15.247	5.765	153	152 (5.76 GHz)		*		*
	5.785	157		√			*
	5.805	161	160 (5.80 GHz)		*	√	*
§15.247	5.825	165		√			*

FCC ID: A3LGTP1010	PCTEST ENGINEERING LABORATORY, INC.	SAR COMPLIANCE REPORT		Reviewed by: Quality Manager
Filename: OY1009221630-R1.A3L	Test Dates: 09/23/10 - 09/29/10	EUT Type: Mini Tablet with WLAN and Bluetooth		Page 17 of 28

## 12.2 Procedures Used to Establish RF Signal for SAR

The device was placed into a simulated connection using the manufacturer provided test software. SAR measurements were taken with a fully charged battery. Power was manually set.

### 12.2.1 IEEE 802.11b Conducted Powers

Mode	Freq [MHz]	Channel	Conducted Power [dBm]			
			Data Rate [Mbps]			
			1	2	5.5	11
802.11b	2412	1	17.01	16.64	16.44	16.23
802.11b	2437	6	16.78	16.71	16.56	16.34
802.11b	2462	11	17.06	17.03	16.88	16.58

### 12.2.1 IEEE 802.11g Conducted Powers



Mode	Freq [MHz]	Channel	Conducted Power [dBm]							
			Data Rate [Mbps]							
			6	9	12	18	24	36	48	54
802.11g	2412	1	14.23	13.99	13.96	14.22	14.11	13.85	14.18	14.20
802.11g	2437	6	14.31	14.01	14.31	14.34	14.33	14.21	14.24	14.17
802.11g	2462	11	14.58	14.33	14.65	14.68	14.59	14.47	14.41	14.46

### 12.2.2 IEEE 802.11n Conducted Powers

Mode	Freq [MHz]	Channel	Conducted Power [dBm]							
			Data Rate [Mbps]							
			6.5	13	20	26	39	52	58	65
802.11n	2412	1	14.22	14.01	13.98	13.89	14.21	13.82	13.75	13.66
802.11n	2437	6	14.45	14.03	13.91	13.98	13.79	14.16	13.85	13.85
802.11n	2462	11	14.47	14.54	14.24	14.38	14.12	14.01	14.09	14.46

### 12.2.3 IEEE 802.11a Conducted Powers

Mode	Freq [MHz]	Channel	Conducted Power [dBm]							
			Data Rate [Mbps]							
			6	9	12	18	24	36	48	54
802.11a	5180	36	12.29	12.28	12.37	12.35	12.32	12.37	12.43	12.44
802.11a	5200	40	11.86	12.02	11.83	11.77	11.83	11.82	11.90	11.92
802.11a	5220	44	11.26	11.46	11.40	11.38	11.37	11.19	11.17	11.07
802.11a	5240	48	11.05	11.04	11.02	11.05	11.09	10.87	11.01	10.84
802.11a	5260	52	10.56	10.51	10.51	10.49	10.59	10.61	10.62	10.70
802.11a	5280	56	10.04	10.21	10.24	10.27	10.31	10.21	10.07	10.12
802.11a	5300	60	9.20	9.30	9.32	9.31	9.19	9.20	9.25	9.34
802.11a	5320	64	9.17	9.17	9.16	9.21	9.19	9.21	9.23	9.26
802.11a	5500	100	7.38	7.39	7.41	7.42	7.40	7.46	7.46	7.49
802.11a	5520	104	6.77	6.70	6.74	6.90	6.86	6.91	6.97	7.03
802.11a	5540	108	6.73	6.84	6.96	6.72	6.80	6.80	6.91	6.96
802.11a	5560	112	6.80	6.71	6.76	6.77	6.81	6.85	6.88	6.73
802.11a	5580	116	6.73	6.73	6.77	6.80	6.71	6.74	6.70	6.73
802.11a	5600	120	6.85	6.83	6.84	6.87	6.89	6.89	6.92	6.93
802.11a	5620	124	6.57	6.59	6.63	6.63	6.64	6.69	6.68	6.65
802.11a	5640	128	6.61	6.55	6.53	6.54	6.59	6.60	6.62	6.63
802.11a	5660	132	6.62	6.60	6.54	6.56	6.58	6.59	6.62	6.60
802.11a	5680	136	6.61	6.54	6.57	6.62	6.43	6.25	6.25	6.18
802.11a	5700	140	6.94	6.93	6.92	6.93	6.94	6.89	6.85	6.87
802.11a	5745	149	11.89	11.87	11.98	11.94	11.72	11.72	11.75	11.74
802.11a	5765	153	11.62	11.23	11.65	11.63	11.72	11.68	11.76	11.75
802.11a	5785	157	12.13	12.08	12.08	12.11	12.09	12.14	12.16	12.12
802.11a	5805	161	12.33	12.31	12.25	12.33	12.35	12.21	12.15	12.18
802.11a	5825	165	n/a	n/a	n/a	n/a	n/a	n/a	n/a	n/a

FCC ID: A3LGP1010		SAR COMPLIANCE REPORT		Reviewed by: Quality Manager
Filename: OY1009221630-R1.A3L	Test Dates: 09/23/10 - 09/29/10	EUT Type: Mini Tablet with WLAN and Bluetooth		Page 18 of 28

## 12.2.4 IEEE 802.11 n Conducted Powers

Mode	Freq [MHz]	Channel	Conducted Power [dBm]							
			Data Rate [Mbps]							
			6.5	13	20	26	39	52	58	65
802.11n	5180	36	12.29	12.35	12.37	12.09	12.08	12.10	12.12	12.13
802.11n	5200	40	11.79	11.86	11.88	11.89	11.91	11.96	11.97	11.99
802.11n	5220	44	11.20	11.17	11.27	11.25	11.29	11.33	11.39	11.35
802.11n	5240	48	10.79	10.81	10.79	10.91	10.85	10.84	10.82	10.86
802.11n	5260	52	10.53	10.55	10.56	10.57	10.61	10.63	10.67	10.64
802.11n	5280	56	10.01	10.03	10.06	10.01	9.91	9.95	9.92	9.96
802.11n	5300	60	9.50	9.49	9.54	9.51	9.41	9.41	9.36	9.39
802.11n	5320	64	9.19	9.15	9.22	9.21	9.01	8.99	9.01	8.99
802.11n	5500	100	7.31	7.29	7.27	7.28	7.30	7.31	7.31	7.35
802.11n	5520	104	6.97	7.03	7.02	6.94	6.95	6.99	6.97	6.97
802.11n	5540	108	6.88	6.92	6.87	6.92	6.81	6.85	6.83	6.85
802.11n	5560	112	6.75	6.78	6.83	6.75	6.67	6.70	6.68	6.71
802.11n	5580	116	6.63	6.64	6.67	6.71	6.71	6.71	6.75	6.74
802.11n	5600	120	6.75	6.77	6.77	6.76	6.83	6.68	6.66	6.68
802.11n	5620	124	6.56	6.55	6.50	6.57	6.53	6.47	6.49	6.50
802.11n	5640	128	6.47	6.02	5.97	5.84	5.94	5.88	5.96	6.01
802.11n	5660	132	6.09	5.99	5.93	5.93	5.89	5.85	5.86	5.80
802.11n	5680	136	5.85	5.79	5.82	5.83	5.91	5.88	6.04	5.93
802.11n	5700	140	6.67	6.68	6.68	6.69	6.70	6.72	6.73	6.73
802.11n	5745	149	10.80	10.74	10.79	10.82	10.85	10.90	10.93	10.92
802.11n	5765	153	11.01	11.08	11.11	11.10	11.10	11.21	11.12	11.20
802.11n	5785	157	11.45	11.31	11.30	11.38	11.32	11.38	11.12	11.28
802.11n	5805	161	11.44	11.40	11.32	11.26	11.39	11.35	11.42	11.34
802.11n	5825	165	n/a	n/a	n/a	n/a	n/a	n/a	n/a	n/a



**Figure 12-1**  
**Power Measurement Setup**

**Notes:**

1. The maximum RF output power for all channels across all data rates were measured.

FCC ID: A3LGTP1010		SAR COMPLIANCE REPORT		Reviewed by: Quality Manager
Filename: OY1009221630-R1.A3L	Test Dates: 09/23/10 - 09/29/10	EUT Type: Mini Tablet with WLAN and Bluetooth		Page 19 of 28



# 13 SAR DATA SUMMARY

**Table 13-1  
2.4 GHz Body SAR Results**

MEASUREMENT RESULTS										
FREQUENCY		Mode	C_Power[dBm]		Position	Service	Spacing	Data Rate (Mbps)	Side	SAR
MHz	Ch.		Start	End						(W/kg)
2462	11	IEEE 802.11b	17.06	17.22	Body	DSSS	0.5 cm	1	back	0.632
2462	11	IEEE 802.11b	17.06	17.18	Body	DSSS	0.5 cm	1	top	0.234
2462	11	IEEE 802.11b	17.06	16.94	Body	DSSS	0.5 cm	1	right	0.044
ANSI / IEEE C95.1 1992 - SAFETY LIMIT Spatial Peak Uncontrolled Exposure/General Population							Body 1.6 W/kg (mW/g) averaged over 1 gram			

**Notes:**

1. The test data reported are the worst-case SAR value with the position set in a typical configuration. Test procedures used were according to FCC/OET Bulletin 65, Supplement C [June 2001].
2. All modes of operation were investigated, and worst-case results are reported.
3. Batteries are fully charged for all readings.
4. Tissue parameters and temperatures are listed on the SAR plots.
5. Liquid tissue depth is was at least 15.0 cm.
6. Device was tested using a fixed spacing.
7. WLAN transmission was verified using a spectrum analyzer.
8. Justification for test configuration per KDB Inquiry 502978. A conservative 5 mm test distance was used for all edges. See Section 11.2 for more details.
9. Justification for reduced test configurations for WIFI channels per KDB Publication 248227 and April 2010 FCC/TCB Meeting Notes: Highest average RF output power channel at the lowest data rate was selected for WLAN for SAR evaluation. Other IEEE 802.11 modes (including 802.11n), were not investigated since the average output powers were not greater than 0.25 dB than that of the corresponding highest output power channel in the lowest data rate IEEE 802.11b mode per channel.



FCC ID: A3LGTP1010	 PCTEST ENGINEERING LABORATORY, INC.	SAR COMPLIANCE REPORT		Reviewed by: Quality Manager
Filename: 0Y1009221630-R1.A3L	Test Dates: 09/23/10 - 09/29/10	EUT Type: Mini Tablet with WLAN and Bluetooth	Page 20 of 28	

**Table 13-2  
Body SAR Results**

<b>MEASUREMENT RESULTS</b>										
<b>FREQUENCY</b>		<b>Mode</b>	<b>Position</b>	<b>C_Power[dBm]</b>		<b>Service</b>	<b>Spacing</b>	<b>Data Rate (Mbps)</b>	<b>Side</b>	<b>SAR (1g)</b>
<b>MHz</b>	<b>Ch.</b>			<b>Start</b>	<b>End</b>					<b>(W/kg)</b>
5180	36	IEEE 802.11a	Body	12.29	12.17	OFDM	0.5 cm	6	back	<b>0.290</b>
5180	36	IEEE 802.11a	Body	12.29	12.24	OFDM	0.5 cm	6	top	0.066
5180	36	IEEE 802.11a	Body	12.29	11.94	OFDM	0.5 cm	6	right	0.000
5260	52	IEEE 802.11a	Body	10.56	10.38	OFDM	0.5 cm	6	back	0.260
5260	52	IEEE 802.11a	Body	10.56	10.51	OFDM	0.5 cm	6	top	0.072
5260	52	IEEE 802.11a	Body	10.56	10.62	OFDM	0.5 cm	6	right	0.003
5500	100	IEEE 802.11a	Body	7.38	7.33	OFDM	0.5 cm	6	back	0.135
5500	100	IEEE 802.11a	Body	7.38	7.42	OFDM	0.5 cm	6	top	0.028
5500	100	IEEE 802.11a	Body	7.38	7.57	OFDM	0.5 cm	6	right	0.000
5805	161	IEEE 802.11a	Body	12.33	12.28	OFDM	0.5 cm	6	back	<b>0.759</b>
5805	161	IEEE 802.11a	Body	12.33	12.48	OFDM	0.5 cm	6	top	0.221
5805	161	IEEE 802.11a	Body	12.33	11.93	OFDM	0.5 cm	6	right	0.001
<b>ANSI / IEEE C95.1 1992 - SAFETY LIMIT</b>							<b>Body</b>			
<b>Spatial Peak</b>							<b>1.6 W/kg (mW/g)</b>			
<b>Uncontrolled Exposure/General Population</b>							averaged over 1 gram			

**Notes:**



1. The test data reported are the worst-case SAR value with the position set in a typical configuration. Test procedures used were according to FCC/OET Bulletin 65, Supplement C [June 2001].
2. All modes of operation were investigated, and worst-case results are reported.
3. Batteries are fully charged for all readings.
4. Tissue parameters and temperatures are listed on the SAR plots.
5. Liquid tissue depth is was at least 15.0 cm.
6. Device was tested using a fixed spacing.
7. WLAN transmission was verified using a spectrum analyzer.
8. Justification for test configuration per KDB Inquiry 502978. A conservative 5 mm test distance was used for all edges. See Section 11.2 for more details.
9. Justification for reduced test configurations for WIFI channels per KDB Publication 248227 and April 2010 FCC/TCB Meeting Notes: Highest average RF output power channel at the lowest data rate was selected for WLAN for SAR evaluation. IEEE 802.11n mode was not investigated since the average output powers were not greater than 0.25 dB than the corresponding channel in IEEE 802.11a mode

<b>FCC ID:</b> A3LGTP1010	 <b>PCTEST</b> ENGINEERING LABORATORY, INC.	<b>SAR COMPLIANCE REPORT</b>		<b>Reviewed by:</b> Quality Manager
<b>Filename:</b> OY1009221630-R1.A3L	<b>Test Dates:</b> 09/23/10 - 09/29/10	<b>EUT Type:</b> Mini Tablet with WLAN and Bluetooth		Page 21 of 28

# 14 EQUIPMENT LIST

Manufacturer	Model	Description	Cal Date	Cal Interval	Cal Due	Serial Number
Agilent	85070B	Dielectric Probe Kit	8/22/2010	Annual	8/22/2011	US33020316
Agilent	8648D	(9kHz-4GHz) Signal Generator	9/19/2009	Biennial	9/19/2011	3613A00315
Agilent	8753E	(30kHz-6GHz) Network Analyzer	3/31/2010	Annual	3/31/2011	JP38020182
Agilent	E8257D	(250kHz-20GHz) Signal Generator	3/30/2010	Annual	3/30/2011	MY45470194
Index SAR	IXTL-010	Dielectric Measurement Kit	N/A		N/A	N/A
Index SAR	IXTL-030	30MM TEM line for 6 GHz	N/A		N/A	N/A
Rohde & Schwarz	CMU200	Base Station Simulator	11/11/2009	Annual	11/11/2010	836371/0079
Rohde & Schwarz	CMU200	Base Station Simulator	6/21/2010	Annual	6/21/2011	833855/0010
Rohde & Schwarz	CMU200	Base Station Simulator	11/4/2009	Annual	11/4/2010	109892
Rohde & Schwarz	NRV-Z32	Peak Power Sensor (100uW-2W)	12/5/2008	Biennial	12/5/2010	100155
Rohde & Schwarz	NRV-Z33	Peak Power Sensor (1mW-20W)	12/5/2008	Biennial	12/5/2010	100004
SPEAG	D1450V2	1450 MHz SAR Dipole	5/20/2009	Biennial	5/20/2011	1025
SPEAG	D1765V2	1765 MHz SAR Dipole	5/19/2009	Biennial	5/19/2011	1008
SPEAG	D1900V2	1900 MHz SAR Dipole	1/20/2009	Biennial	1/20/2011	502
SPEAG	D1900V2	1900 MHz SAR Dipole	8/18/2009	Biennial	8/18/2011	5d080
SPEAG	D2450V2	2450 MHz SAR Dipole	8/27/2009	Biennial	8/27/2011	719
SPEAG	D2450V2	2450 MHz SAR Dipole	1/8/2009	Biennial	1/8/2011	797
SPEAG	D2600V2	2600 MHz SAR Dipole	8/12/2009	Biennial	8/12/2011	1004
SPEAG	D5GHzV2	5 GHz SAR Dipole	8/19/2009	Biennial	8/19/2011	1007
SPEAG	D5GHzV2	5 GHz SAR Dipole	1/15/2009	Biennial	1/15/2011	1057
SPEAG	D835V2	835 MHz SAR Dipole	1/19/2009	Biennial	1/19/2011	4d047
SPEAG	D835V2	835 MHz SAR Dipole	8/24/2009	Biennial	8/24/2011	4d026
SPEAG	DAE4	Dasy Data Acquisition Electronics	3/22/2010	Annual	3/22/2011	704
SPEAG	DAE4	Dasy Data Acquisition Electronics	4/21/2010	Annual	4/21/2011	665
SPEAG	DAE4	Dasy Data Acquisition Electronics	1/22/2010	Annual	1/22/2011	649
SPEAG	EX3DV4	SAR Probe	8/19/2010	Annual	8/19/2011	3561
SPEAG	EX3DV4	SAR Probe	1/26/2010	Annual	1/26/2011	3550
SPEAG	DAE4	Dasy Data Acquisition Electronics	7/8/2010	Annual	7/8/2011	859
SPEAG	D750V3	750 MHz Dipole	8/19/2010	Biennial	8/19/2012	1003
SPEAG	ES3DV3	SAR Probe	3/16/2010	Annual	3/16/2011	3213
SPEAG	ES3DV3	SAR Probe	4/20/2010	Annual	4/20/2011	3209
Rohde & Schwarz	SMIQ03B	Signal Generator	4/1/2010	Annual	4/1/2011	DE27259
SPEAG	D1640V2	1640 MHz Dipole	8/17/2010	Biennial	8/17/2012	321
Rohde & Schwarz	CMW500	LTE Radio Communication Tester	8/30/2010	Annual	8/30/2011	100976
Anritsu	MA2481A	Power Sensor	12/2/2009	Annual	12/2/2010	5318
Anritsu	MA2481A	Power Sensor	12/3/2009	Annual	12/3/2010	5442
Anritsu	ML2438A	Power Meter	12/3/2009	Annual	12/3/2010	1190013
Anritsu	ML2438A	Power Meter	12/3/2009	Annual	12/3/2010	98150041
Agilent	8648D	Signal Generator	4/1/2010	Annual	4/1/2011	3629U00687
Anritsu	ML2438A	Power Meter	12/3/2009	Annual	12/3/2010	1070030
Anritsu	MA2481A	Power Sensor	12/2/2009	Annual	12/2/2010	5821
Anritsu	MA2481A	Power Sensor	12/3/2009	Annual	12/3/2010	8013
Anritsu	MA2481A	Power Sensor	12/3/2009	Annual	12/3/2010	2400
Apral	ALS-PR-DIEL	Dielectric Probe Kit	N/A		N/A	260-00959
Agilent	E5515C	Wireless Communications Tester	4/14/2010	Annual	4/14/2011	US41140256
SPEAG	ES3DV3	SAR Probe	2/10/2010	Annual	2/10/2011	3173

Justification for 2-year calibration cycle for SAR dipoles is found in Section 10.3.



FCC ID: A3LGTP1010	 PCTEST Engineering Laboratory, Inc.	SAR COMPLIANCE REPORT		Reviewed by: Quality Manager
Filename: OY1009221630-R1.A3L	Test Dates: 09/23/10 - 09/29/10	EUT Type: Mini Tablet with WLAN and Bluetooth	Page 22 of 28	

# 15 CONCLUSION

## 15.1 Measurement Conclusion



The SAR evaluation indicates that the EUT complies with the RF radiation exposure limits of the FCC and Industry Canada, with respect to all parameters subject to this test. These measurements were taken to simulate the RF effects of RF exposure under worst-case conditions. Precise laboratory measures were taken to assure repeatability of the tests. The results and statements relate only to the item(s) tested.

Please note that the absorption and distribution of electromagnetic energy in the body are very complex phenomena that depend on the mass, shape, and size of the body, the orientation of the body with respect to the field vectors, and the electrical properties of both the body and the environment. Other variables that may play a substantial role in possible biological effects are those that characterize the environment (e.g. ambient temperature, air velocity, relative humidity, and body insulation) and those that characterize the individual (e.g. age, gender, activity level, debilitation, or disease). Because various factors may interact with one another to vary the specific biological outcome of an exposure to electromagnetic fields, any protection guide should consider maximal amplification of biological effects as a result of field-body interactions, environmental conditions, and physiological variables. [3]



<b>FCC ID:</b> A3LGTP1010		<b>SAR COMPLIANCE REPORT</b>		<b>Reviewed by:</b> Quality Manager
<b>Filename:</b> 0Y1009221630-R1.A3L	<b>Test Dates:</b> 09/23/10 - 09/29/10	<b>EUT Type:</b> Mini Tablet with WLAN and Bluetooth	Page 23 of 28	

## 16 REFERENCES

- [1] Federal Communications Commission, ET Docket 93-62, Guidelines for Evaluating the Environmental Effects of Radiofrequency Radiation, Aug. 1996.
- [2] ANSI/IEEE C95.1-2005, American National Standard safety levels with respect to human exposure to radio frequency electromagnetic fields, 300kHz to 100GHz, New York: IEEE, 2006.
- [3] ANSI/IEEE C95.1-1992, American National Standard safety levels with respect to human exposure to radio frequency electromagnetic fields, 300kHz to 100GHz, New York: IEEE, Sept. 1992.
- [4] ANSI/IEEE C95.3-2002, IEEE Recommended Practice for the Measurement of Potentially Hazardous Electromagnetic Fields - RF and Microwave, New York: IEEE, December 2002.
- [5] Federal Communications Commission, OET Bulletin 65 (Edition 97-01), Supplement C (Edition 01-01), Evaluating Compliance with FCC Guidelines for Human Exposure to Radiofrequency Electromagnetic Fields, June 2001.
- [6] IEEE Standards Coordinating Committee 34 – IEEE Std. 1528-2003, Recommended Practice for Determining the Peak Spatial-Average Specific Absorption Rate (SAR) in the Human Body Due to Wireless Communications Devices.
- [7] NCRP, National Council on Radiation Protection and Measurements, Biological Effects and Exposure Criteria for RadioFrequency Electromagnetic Fields, NCRP Report No. 86, 1986. Reprinted Feb. 1995.
- [8] T. Schmid, O. Egger, N. Kuster, Automated E-field scanning system for dosimetric assessments, IEEE Transaction on Microwave Theory and Techniques, vol. 44, Jan. 1996, pp. 105-113.
- [9] K. Pokovic, T. Schmid, N. Kuster, Robust setup for precise calibration of E-field probes in tissue simulating liquids at mobile communications frequencies, ICECOM97, Oct. 1997, pp. 120-124.
- [10] K. Pokovic, T. Schmid, and N. Kuster, E-field Probe with improved isotropy in brain simulating liquids, Proceedings of the ELMAR, Zadar, Croatia, June 23-25, 1996, pp. 172-175.
- [11] Schmid & Partner Engineering AG, Application Note: Data Storage and Evaluation, June 1998, p2.
- [12] V. Hombach, K. Meier, M. Burkhardt, E. Kuhn, N. Kuster, The Dependence of EM Energy Absorption upon Human Head Modeling at 900 MHz, IEEE Transaction on Microwave Theory and Techniques, vol. 44 no. 10, Oct. 1996, pp. 1865-1873.
- [13] N. Kuster and Q. Balzano, Energy absorption mechanism by biological bodies in the near field of dipole antennas above 300MHz, IEEE Transaction on Vehicular Technology, vol. 41, no. 1, Feb. 1992, pp. 17-23.
- [14] G. Hartsgrove, A. Kraszewski, A. Surowiec, Simulated Biological Materials for Electromagnetic Radiation Absorption Studies, University of Ottawa, Bioelectromagnetics, Canada: 1987, pp. 29-36.
- [15] Q. Balzano, O. Garay, T. Manning Jr., Electromagnetic Energy Exposure of Simulated Users of Portable Cellular Telephones, IEEE Transactions on Vehicular Technology, vol. 44, no.3, Aug. 1995.

<b>FCC ID:</b> A3LGTP1010		<b>SAR COMPLIANCE REPORT</b>		<b>Reviewed by:</b> Quality Manager
<b>Filename:</b> 0Y1009221630-R1.A3L	<b>Test Dates:</b> 09/23/10 - 09/29/10	<b>EUT Type:</b> Mini Tablet with WLAN and Bluetooth	Page 24 of 28	

- [16] W. Gander, Computermathematick, Birkhaeuser, Basel, 1992.
- [17] W.H. Press, S.A. Teukolsky, W.T. Vetterling, and B.P. Flannery, Numerical Receptions in C, The Art of Scientific Computing, Second edition, Cambridge University Press, 1992.
- [18] Federal Communications Commission, OET Bulletin 65, Evaluating Compliance with FCC Guidelines for Human Exposure to Radiofrequency Electromagnetic Fields. Supplement C, Dec. 1997.
- [19] N. Kuster, R. Kastle, T. Schmid, Dosimetric evaluation of mobile communications equipment with known precision, IEEE Transaction on Communications, vol. E80-B, no. 5, May 1997, pp. 645-652.
- [20] CENELEC CLC/SC111B, European Prestandard (prENV 50166-2), Human Exposure to Electromagnetic Fields High-frequency: 10kHz-300GHz, Jan. 1995.
- [21] Prof. Dr. Niels Kuster, ETH, Eidgenössische Technische Hochschule Zürich, Dosimetric Evaluation of the Cellular Phone.
- [22] IEC 62209-1, Human exposure to radio frequency fields from hand-held and body-mounted wireless communication devices - Human models, instrumentation, and procedures - Part 1: Procedure to determine the specific absorption rate (SAR) for hand-held devices used in close proximity to the ear (frequency range of 300 MHz to 3 GHz), Feb. 2005.
- [23] Industry Canada RSS-102 Radio Frequency Exposure Compliance of Radiocommunication Apparatus (All Frequency Bands) Issue 4, March 2010.
- [24] Health Canada Safety Code 6 Limits of Human Exposure to Radio Frequency Electromagnetic Fields in the Frequency Range from 3 kHz – 300 GHz, 2009
- [25] FCC Public Notice DA-02-1438. Office of Engineering and Technology Announces a Transition Period for the Phantom Requirements of Supplement C to OET Bulletin 65, June 19, 2002
- [26] FCC SAR Measurement Procedures for 3G Devices KDB 941225
- [27] SAR Measurement procedures for IEEE 802.11a/b/g KDB 248227
- [28] FCC SAR Considerations for Handsets with Multiple Transmitters and Antennas, KDB 648474
- [29] FCC Application Note for SAR Probe Calibration and System Verification Consideration for Measurements at 150 MHz – 3 GHz, KDB 450824
- [30] FCC SAR Evaluation Considerations for Laptop Computers with Antennas Built-in on Display Screens, KDB 616217
- [31] FCC SAR Measurement Requirements for 3 – 6 GHz, KDB 865664
- [32] FCC Mobile Portable RF Exposure Procedure, KDB 447498
- [33] FCC SAR Procedures for Dongle Transmitters, KDB 447498
- [34] Anexo à Resolução No. 533, de 10 de Setembro de 2009.

<b>FCC ID:</b> A3LGTP1010	 <b>PCTEST</b> ENGINEERING LABORATORY, INC.	<b>SAR COMPLIANCE REPORT</b>		<b>Reviewed by:</b> Quality Manager
<b>Filename:</b> 0Y1009221630-R1.A3L	<b>Test Dates:</b> 09/23/10 - 09/29/10	<b>EUT Type:</b> Mini Tablet with WLAN and Bluetooth		Page 25 of 28

## **APPENDIX A: SAR TEST DATA**

# PCTEST ENGINEERING LABORATORY, INC.

**DUT: A3LGTP1010; Type: Mini-Tablet with Bluetooth and WLAN; Serial: FH-218-C**

Communication System: IEEE 802.11b; Frequency: 2462 MHz; Duty Cycle: 1:1  
Medium: 2450 Muscle Medium parameters used (interpolated):

$$f = 2462 \text{ MHz}; \sigma = 1.95 \text{ mho/m}; \epsilon_r = 50.7; \rho = 1000 \text{ kg/m}^3$$

Phantom section: Flat Section; Space: 0.5 cm

Test Date: 09-23-2010; Ambient Temp: 24.7°C; Tissue Temp: 23.3°C

Probe: EX3DV4 - SN3550; ConvF(6.4, 6.4, 6.4); Calibrated: 1/26/2010

Sensor-Surface: 4mm (Mechanical Surface Detection)

Electronics: DAE4 Sn649; Calibrated: 1/22/2010

Phantom: SAM Main; Type: SAM 4.0; Serial: TP-1114

Measurement SW: DASY4, V4.7 Build 80; Postprocessing SW: SEMCAD, V1.8 Build 186

**Mode: IEEE 802.11b, Body Back, Ch 11, 1 Mbps**

**Area Scan (11x17x1):** Measurement grid: dx=15mm, dy=15mm

**Zoom Scan (5x5x7)/Cube 0:** Measurement grid: dx=8mm, dy=8mm, dz=5mm

Reference Value = 17.0 V/m

Peak SAR (extrapolated) = 1.42 W/kg

**SAR(1 g) = 0.632 mW/g; SAR(10 g) = 0.303 mW/g**

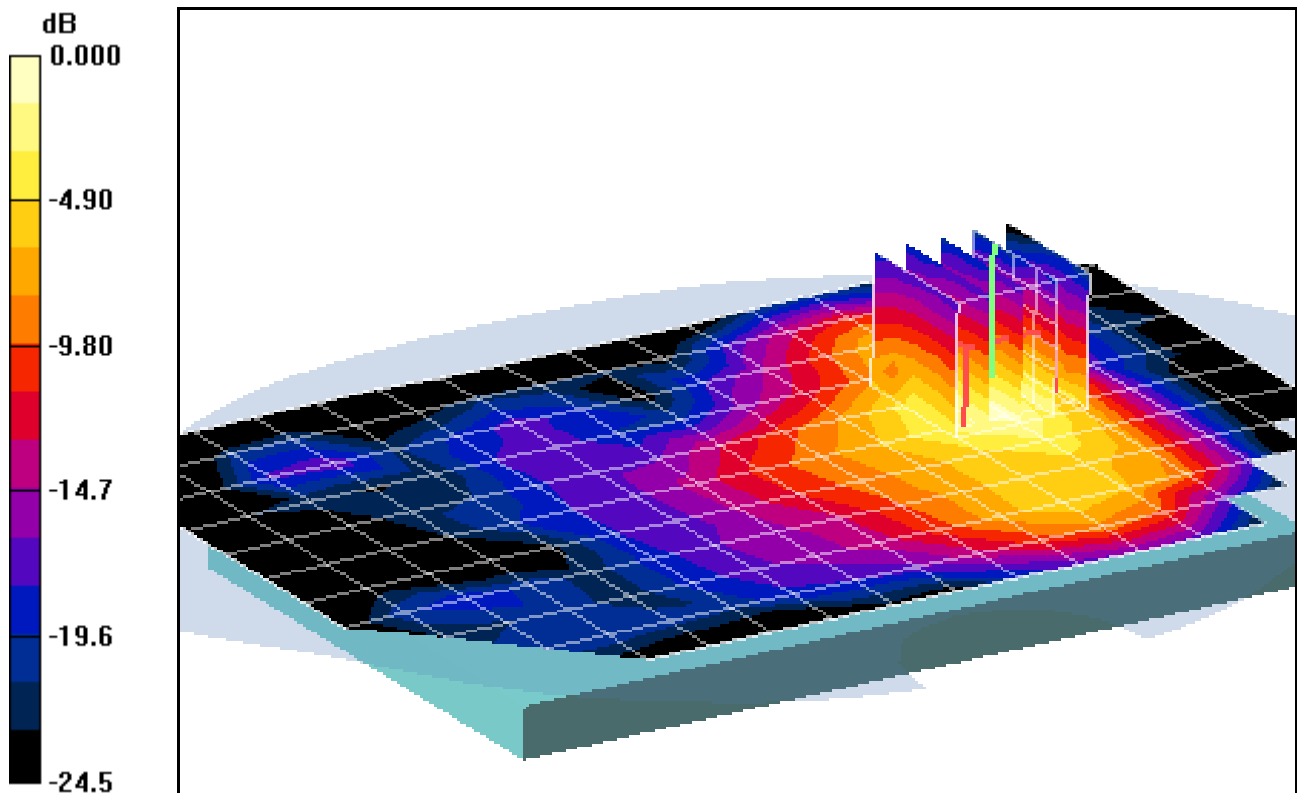

0 dB = 0.617mW/g

# PCTEST ENGINEERING LABORATORY, INC.

**DUT: A3LGTP1010; Type: Mini-Tablet with Bluetooth and WLAN; Serial: FH-218-C**

Communication System: IEEE 802.11b; Frequency: 2462 MHz; Duty Cycle: 1:1  
Medium: 2450 Muscle Medium parameters used (interpolated):

$$f = 2462 \text{ MHz}; \sigma = 1.95 \text{ mho/m}; \epsilon_r = 50.7; \rho = 1000 \text{ kg/m}^3$$

Phantom section: Flat Section; Space: 0.5 cm

Test Date: 09-23-2010; Ambient Temp: 24.7°C; Tissue Temp: 23.3°C

Probe: EX3DV4 - SN3550; ConvF(6.4, 6.4, 6.4); Calibrated: 1/26/2010

Sensor-Surface: 4mm (Mechanical Surface Detection)

Electronics: DAE4 Sn649; Calibrated: 1/22/2010

Phantom: SAM Main; Type: SAM 4.0; Serial: TP-1114

Measurement SW: DASY4, V4.7 Build 80; Postprocessing SW: SEMCAD, V1.8 Build 186

**Mode: IEEE 802.11b, Body Back, Ch 11, 1 Mbps**

**Area Scan (11x17x1):** Measurement grid: dx=15mm, dy=15mm

**Zoom Scan (5x5x7)/Cube 0:** Measurement grid: dx=8mm, dy=8mm, dz=5mm

Reference Value = 17.0 V/m

Peak SAR (extrapolated) = 1.42 W/kg

**SAR(1 g) = 0.632 mW/g; SAR(10 g) = 0.303 mW/g**

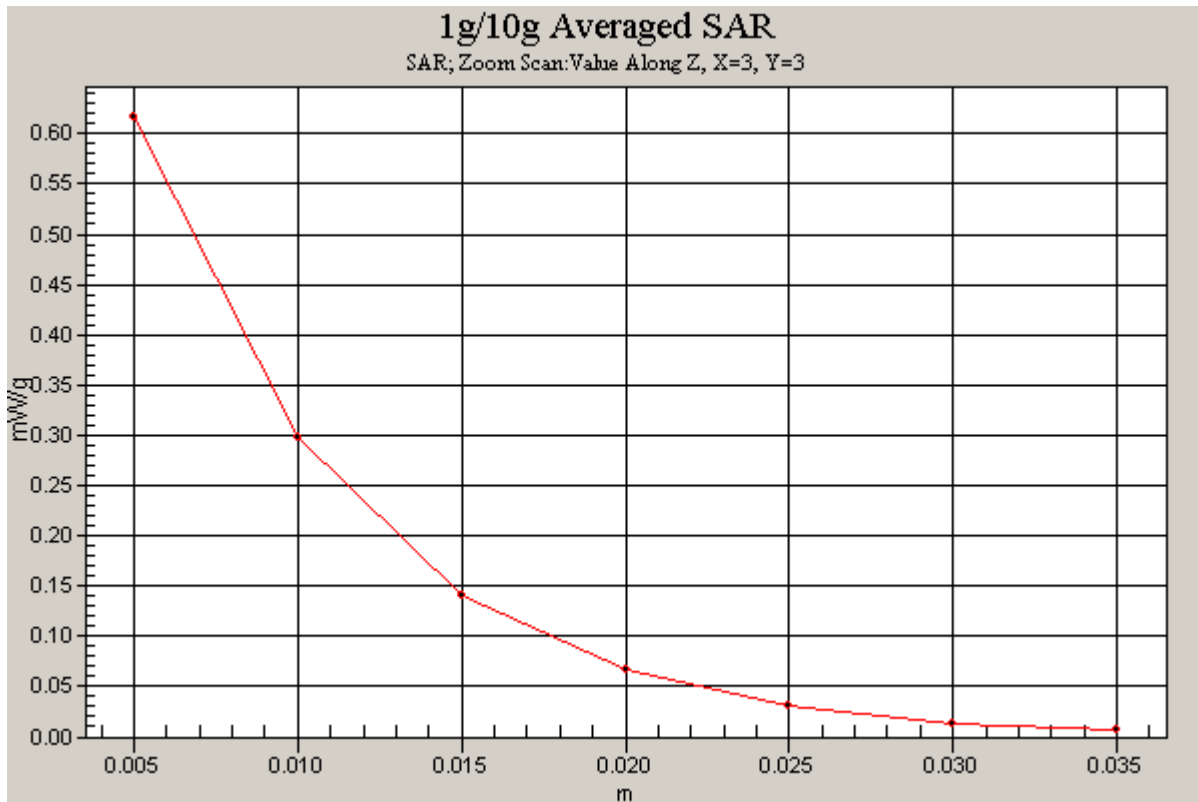

# PCTEST ENGINEERING LABORATORY, INC.

**DUT: A3LGTP1010; Type: Mini-Tablet with Bluetooth and WLAN; Serial: FH-218-C**

Communication System: IEEE 802.11b; Frequency: 2462 MHz; Duty Cycle: 1:1

Medium: 2450 Muscle Medium parameters used (interpolated):

$f = 2462 \text{ MHz}$ ;  $\sigma = 1.95 \text{ mho/m}$ ;  $\epsilon_r = 50.7$ ;  $\rho = 1000 \text{ kg/m}^3$

Phantom section: Flat Section; Space: 0.5 cm

Test Date: 09-23-2010; Ambient Temp: 24.7°C; Tissue Temp: 23.3°C

Probe: EX3DV4 - SN3550; ConvF(6.4, 6.4, 6.4); Calibrated: 1/26/2010

Sensor-Surface: 4mm (Mechanical Surface Detection)

Electronics: DAE4 Sn649; Calibrated: 1/22/2010

Phantom: SAM Main; Type: SAM 4.0; Serial: TP-1114

Measurement SW: DASY4, V4.7 Build 80; Postprocessing SW: SEMCAD, V1.8 Build 186

**Mode: IEEE 802.11b, Top, Ch 11, 1 Mbps**

**Area Scan (5x11x1):** Measurement grid: dx=15mm, dy=15mm

**Zoom Scan (5x5x7)/Cube 0:** Measurement grid: dx=8mm, dy=8mm, dz=5mm

Reference Value = 11.3 V/m

Peak SAR (extrapolated) = 0.422 W/kg

**SAR(1 g) = 0.234 mW/g; SAR(10 g) = 0.120 mW/g**

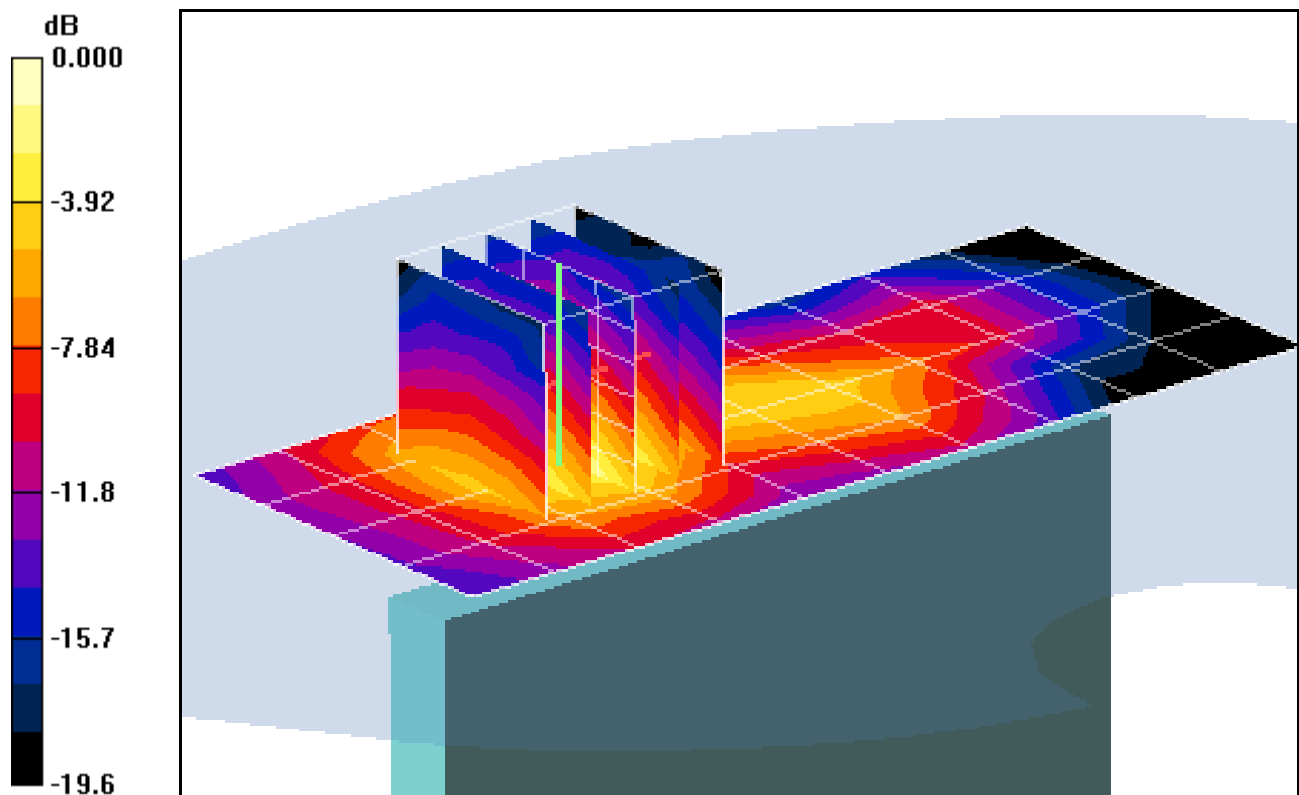

0 dB = 0.264mW/g

# PCTEST ENGINEERING LABORATORY, INC.

**DUT: A3LGTP1010; Type: Mini-Tablet with Bluetooth and WLAN; Serial: FH-218-C**

Communication System: IEEE 802.11b; Frequency: 2462 MHz; Duty Cycle: 1:1

Medium: 2450 Muscle Medium parameters used (interpolated):

$f = 2462 \text{ MHz}$ ;  $\sigma = 1.95 \text{ mho/m}$ ;  $\epsilon_r = 50.7$ ;  $\rho = 1000 \text{ kg/m}^3$

Phantom section: Flat Section; Space: 0.5 cm

Test Date: 09-23-2010; Ambient Temp: 24.7°C; Tissue Temp: 23.3°C

Probe: EX3DV4 - SN3550; ConvF(6.4, 6.4, 6.4); Calibrated: 1/26/2010

Sensor-Surface: 4mm (Mechanical Surface Detection)

Electronics: DAE4 Sn649; Calibrated: 1/22/2010

Phantom: SAM Main; Type: SAM 4.0; Serial: TP-1114

Measurement SW: DASY4, V4.7 Build 80; Postprocessing SW: SEMCAD, V1.8 Build 186

**Mode: IEEE 802.11b, Right, Ch 11, 1 Mbps**

**Area Scan (4x17x1):** Measurement grid: dx=15mm, dy=15mm

**Zoom Scan (5x5x7)/Cube 0:** Measurement grid: dx=8mm, dy=8mm, dz=5mm

Reference Value = 5.03 V/m

Peak SAR (extrapolated) = 0.083 W/kg

**SAR(1 g) = 0.044 mW/g; SAR(10 g) = 0.022 mW/g**

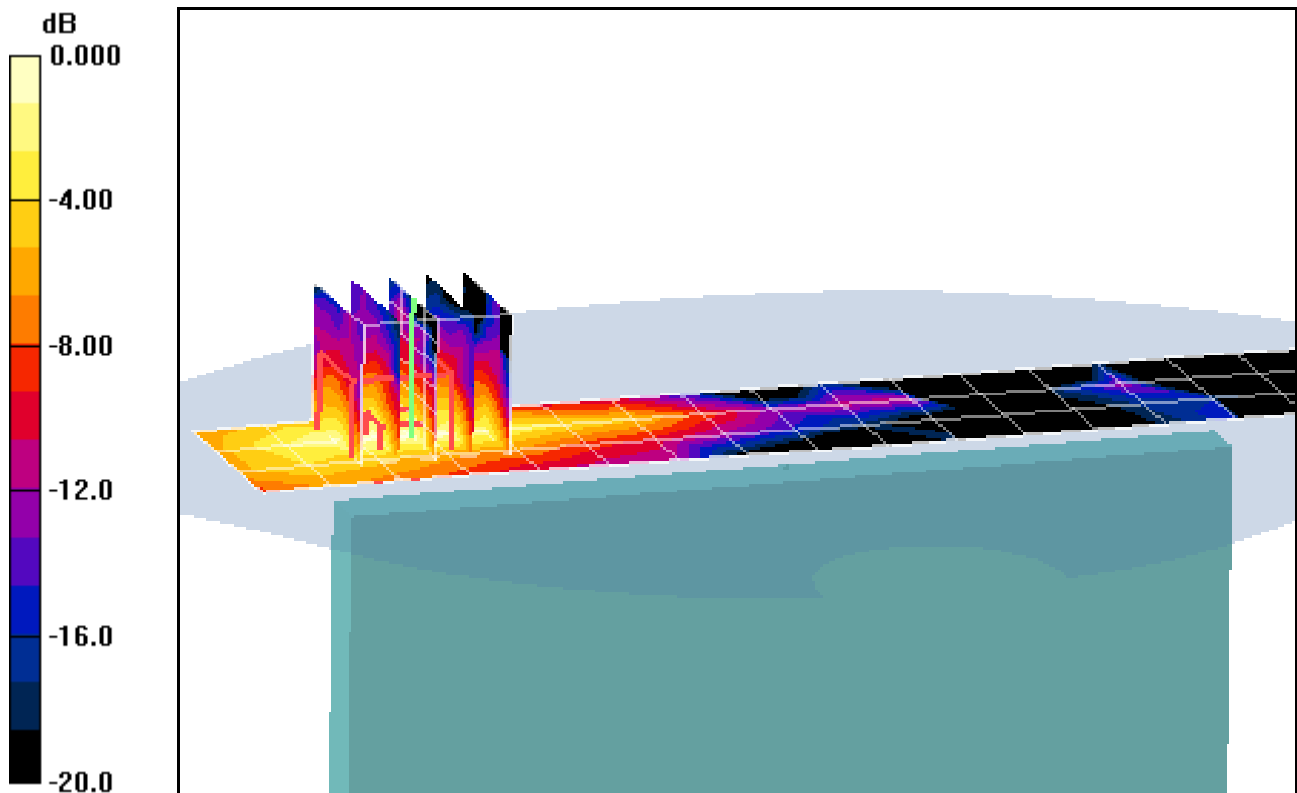

0 dB = 0.045mW/g

# PCTEST ENGINEERING LABORATORY, INC.

**DUT: A3LGTP1010; Type: Mini-Tablet with Bluetooth and WLAN; Serial: FH-218-C**

Communication System: IEEE 802.11a 5.2-5.8 GHz Band; Frequency: 5180 MHz; Duty Cycle: 1:1  
Medium: 5.2 to 5.8 GHz Muscle Medium parameters used (interpolated):

$$f = 5180 \text{ MHz}; \sigma = 5.143 \text{ mho/m}; \epsilon_r = 47.1; \rho = 1000 \text{ kg/m}^3$$

Phantom section: Flat Section; Space: 0.5 cm

Test Date: 09-28-2010; Ambient Temp: 24.3°C; Tissue Temp: 22.4°C

Probe: EX3DV4 - SN3550; ConvF(3.73, 3.73, 3.73); Calibrated: 1/26/2010

Sensor-Surface: 2mm (Mechanical Surface Detection)

Electronics: DAE4 Sn649; Calibrated: 1/22/2010

Phantom: SAM Main; Type: SAM 4.0; Serial: TP-1114

Measurement SW: DASY4, V4.7 Build 80; Postprocessing SW: SEMCAD, V1.8 Build 186

**Mode: WLAN 802.11a 5.2 GHz, Body Back, Ch 36, 1 Mbps**

**Area Scan (16x23x1):** Measurement grid: dx=10mm, dy=10mm

**Zoom Scan (6x6x9)/Cube 0:** Measurement grid: dx=4.6mm, dy=4.6mm, dz=2.8mm

Reference Value = 9.57 V/m

Peak SAR (extrapolated) = 1.13 W/kg

**SAR(1 g) = 0.290 mW/g; SAR(10 g) = 0.080 mW/g**

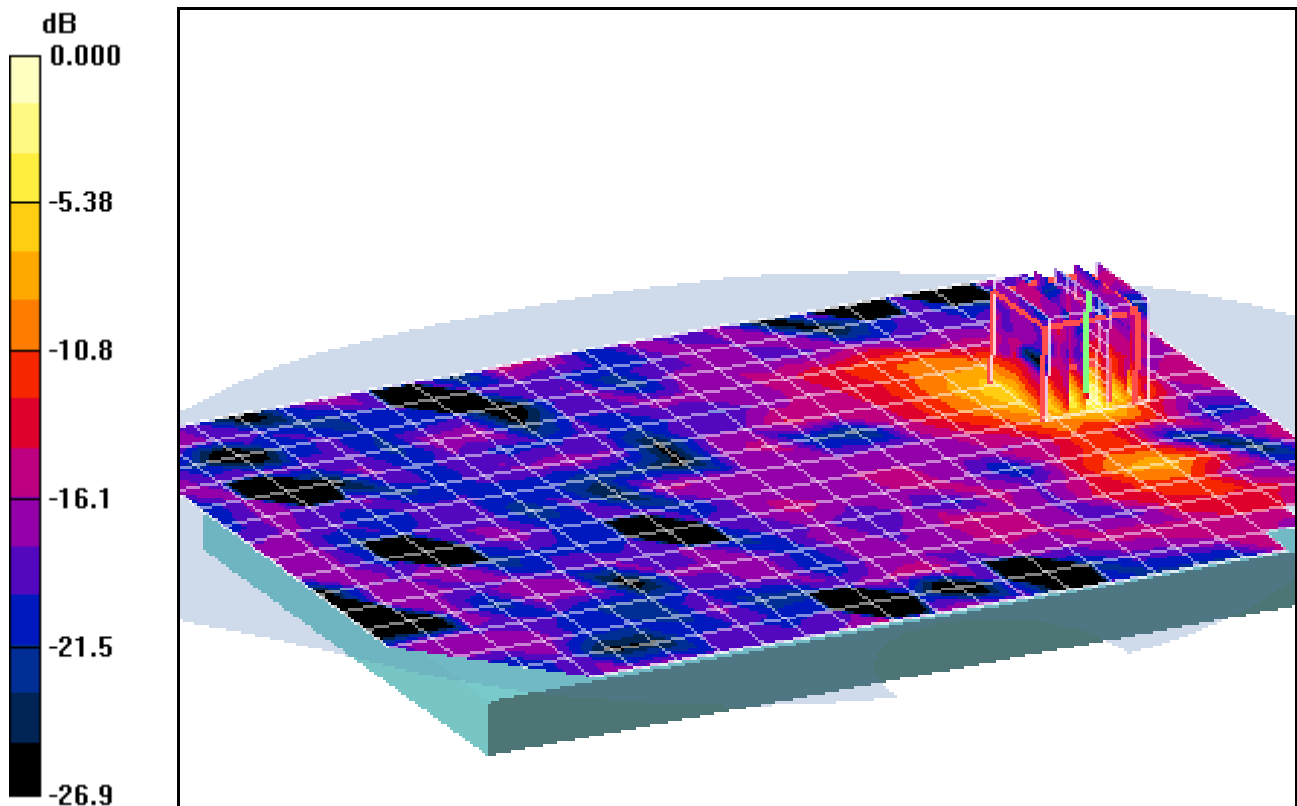

0 dB = 0.632mW/g

# PCTEST ENGINEERING LABORATORY, INC.

**DUT: A3LGTP1010; Type: Mini-Tablet with Bluetooth and WLAN; Serial: FH-218-C**

Communication System: IEEE 802.11a 5.2-5.8 GHz Band; Frequency: 5180 MHz; Duty Cycle: 1:1  
Medium: 5.2 to 5.8 GHz Muscle Medium parameters used (interpolated):

$$f = 5180 \text{ MHz}; \sigma = 5.14 \text{ mho/m}; \epsilon_r = 47.9; \rho = 1000 \text{ kg/m}^3$$

Phantom section: Flat Section; Space: 0.5 cm

Test Date: 09-28-2010; Ambient Temp: 24.3°C; Tissue Temp: 22.4°C

Probe: EX3DV4 - SN3550; ConvF(3.73, 3.73, 3.73); Calibrated: 1/26/2010

Sensor-Surface: 2mm (Mechanical Surface Detection)

Electronics: DAE4 Sn649; Calibrated: 1/22/2010

Phantom: SAM Main; Type: SAM 4.0; Serial: TP-1114

Measurement SW: DASY4, V4.7 Build 80; Postprocessing SW: SEMCAD, V1.8 Build 186

**Mode: WLAN 802.11a 5.2 GHz, Top, Ch 36, 1 Mbps**

**Area Scan (7x15x1):** Measurement grid: dx=10mm, dy=10mm

**Zoom Scan (6x6x9)/Cube 0:** Measurement grid: dx=4.6mm, dy=4.6mm, dz=2.8mm

Reference Value = 4.57 V/m

Peak SAR (extrapolated) = 0.225 W/kg

**SAR(1 g) = 0.066 mW/g; SAR(10 g) = 0.023 mW/g**

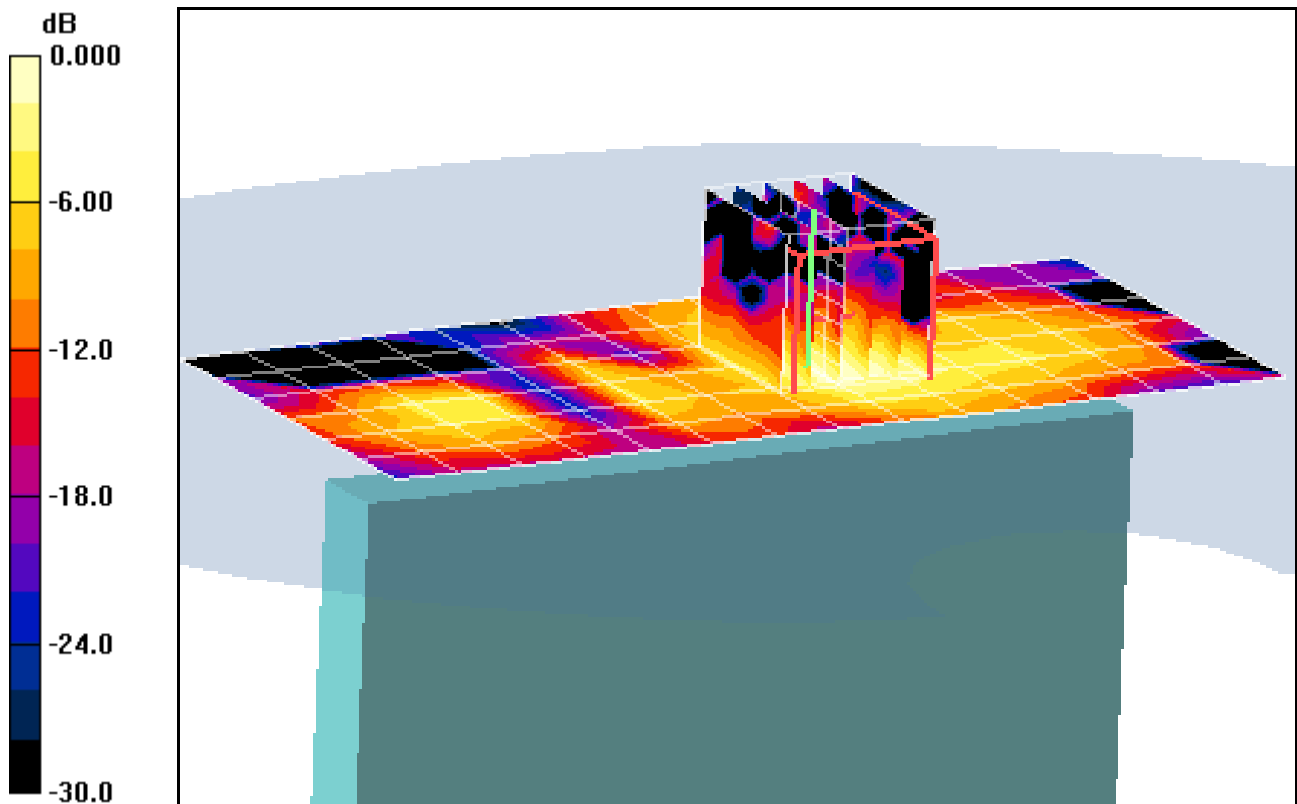

0 dB = 0.124mW/g

# PCTEST ENGINEERING LABORATORY, INC.

**DUT: A3LGTP1010; Type: Mini-Tablet with Bluetooth and WLAN; Serial: FH-218-C**

Communication System: IEEE 802.11a 5.2-5.8 GHz Band; Frequency: 5180 MHz; Duty Cycle: 1:1  
Medium: 5.2 to 5.8 GHz Muscle Medium parameters used (interpolated):

$$f = 5180 \text{ MHz}; \sigma = 5.14 \text{ mho/m}; \epsilon_r = 47.9; \rho = 1000 \text{ kg/m}^3$$

Phantom section: Flat Section; Space: 0.5 cm

Test Date: 09-28-2010; Ambient Temp: 24.3°C; Tissue Temp: 22.4°C

Probe: EX3DV4 - SN3550; ConvF(3.73, 3.73, 3.73); Calibrated: 1/26/2010

Sensor-Surface: 2mm (Mechanical Surface Detection)

Electronics: DAE4 Sn649; Calibrated: 1/22/2010

Phantom: SAM Main; Type: SAM 4.0; Serial: TP-1114

Measurement SW: DASY4, V4.7 Build 80; Postprocessing SW: SEMCAD, V1.8 Build 186

**Mode: WLAN 802.11a 5.2 GHz, Right, Ch 36, 1 Mbps**

**Area Scan (7x22x1):** Measurement grid: dx=10mm, dy=10mm

**Zoom Scan (6x6x9)/Cube 0:** Measurement grid: dx=4.6mm, dy=4.6mm, dz=2.8mm

Reference Value = 0.414 V/m

Peak SAR (extrapolated) = 0.007 W/kg

**SAR(1 g) = 0.000231 mW/g; SAR(10 g) = 2.62e-005 mW/g**

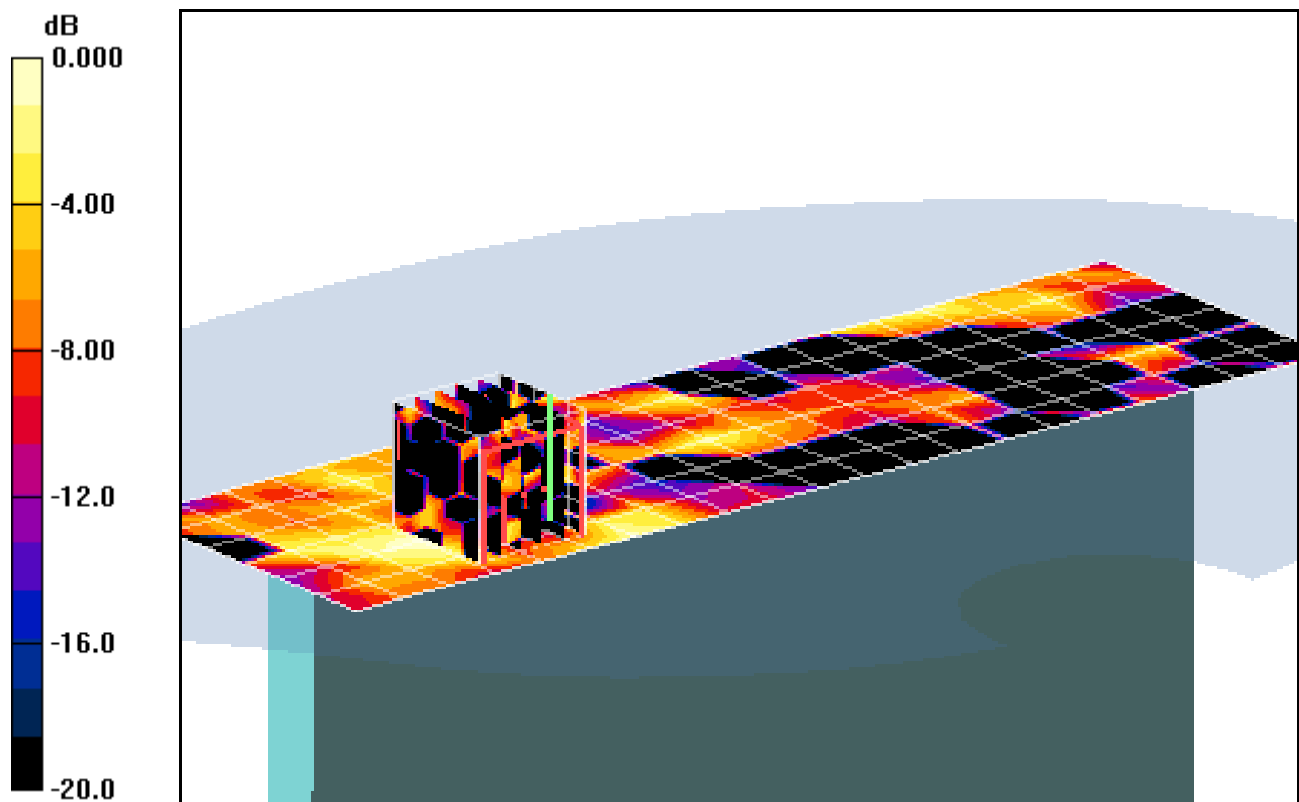

0 dB = 0.011mW/g

# PCTEST ENGINEERING LABORATORY, INC.

**DUT: A3LGTP1010; Type: Mini-Tablet with Bluetooth and WLAN; Serial: FH-218-C**

Communication System: IEEE 802.11a 5.2-5.8 GHz Band; Frequency: 5260 MHz; Duty Cycle: 1:1  
Medium: 5.2 to 5.8 GHz Muscle Medium parameters used (interpolated):

$$f = 5260 \text{ MHz}; \sigma = 5.26 \text{ mho/m}; \epsilon_r = 46.9; \rho = 1000 \text{ kg/m}^3$$

Phantom section: Flat Section; Space: 0.5 cm

Test Date: 09-28-2010; Ambient Temp: 24.3°C; Tissue Temp: 22.4°C

Probe: EX3DV4 - SN3550; ConvF(3.52, 3.52, 3.52); Calibrated: 1/26/2010

Sensor-Surface: 2mm (Mechanical Surface Detection)

Electronics: DAE4 Sn649; Calibrated: 1/22/2010

Phantom: SAM Main; Type: SAM 4.0; Serial: TP-1114

Measurement SW: DASY4, V4.7 Build 80; Postprocessing SW: SEMCAD, V1.8 Build 186

**Mode: WLAN 802.11a 5.3 GHz, Body Back, Ch 52, 1 Mbps**

**Area Scan (16x23x1):** Measurement grid: dx=10mm, dy=10mm

**Zoom Scan (6x6x9)/Cube 0:** Measurement grid: dx=4.6mm, dy=4.6mm, dz=2.8mm

Reference Value = 7.23 V/m

Peak SAR (extrapolated) = 0.909 W/kg

**SAR(1 g) = 0.260 mW/g; SAR(10 g) = 0.057 mW/g**

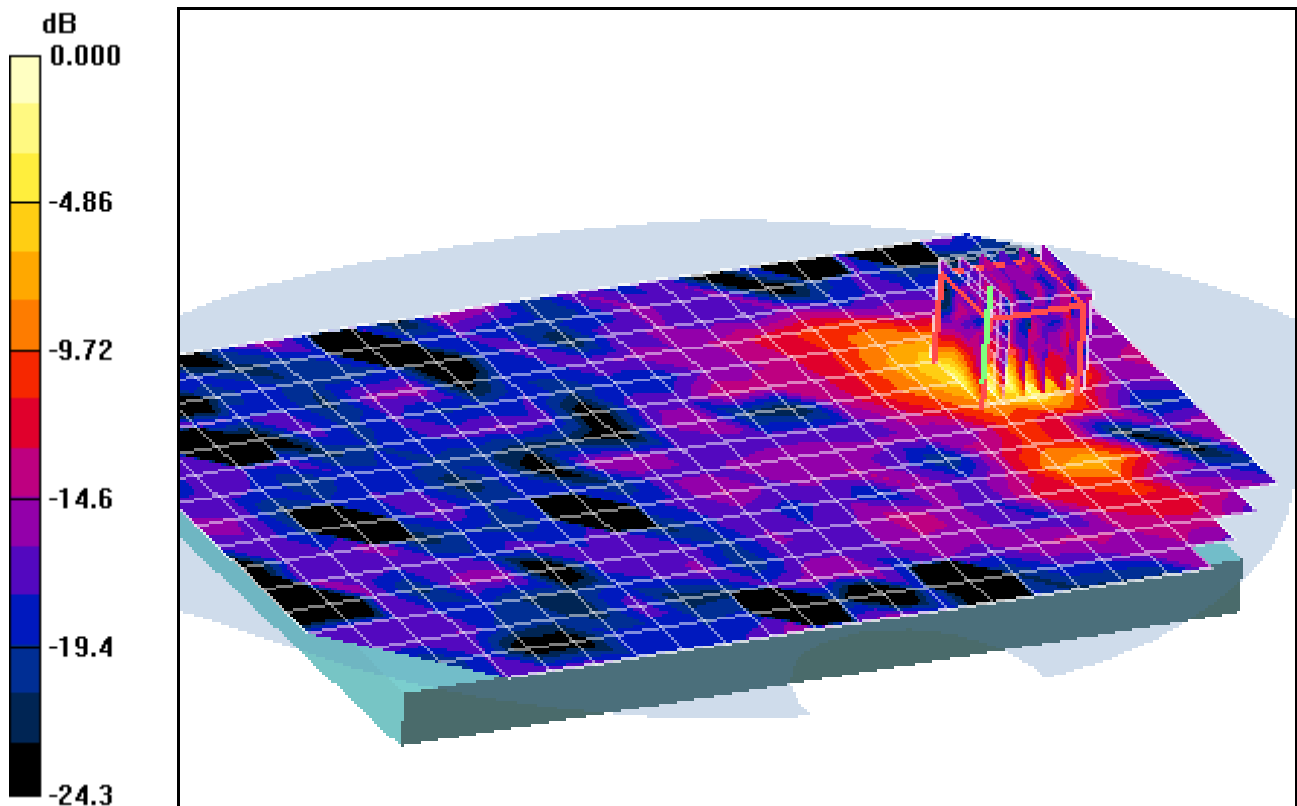

0 dB = 0.534mW/g

# PCTEST ENGINEERING LABORATORY, INC.

**DUT: A3LGTP1010; Type: Mini-Tablet with Bluetooth and WLAN; Serial: FH-218-C**

Communication System: IEEE 802.11a 5.2-5.8 GHz Band; Frequency: 5260 MHz; Duty Cycle: 1:1  
Medium: 5.2 to 5.8 GHz Muscle Medium parameters used (interpolated):

$$f = 5260 \text{ MHz}; \sigma = 5.26 \text{ mho/m}; \epsilon_r = 46.9; \rho = 1000 \text{ kg/m}^3$$

Phantom section: Flat Section; Space: 0.5 cm

Test Date: 09-28-2010; Ambient Temp: 24.3°C; Tissue Temp: 22.4°C

Probe: EX3DV4 - SN3550; ConvF(3.52, 3.52, 3.52); Calibrated: 1/26/2010

Sensor-Surface: 2mm (Mechanical Surface Detection)

Electronics: DAE4 Sn649; Calibrated: 1/22/2010

Phantom: SAM Main; Type: SAM 4.0; Serial: TP-1114

Measurement SW: DASY4, V4.7 Build 80; Postprocessing SW: SEMCAD, V1.8 Build 186

**Mode: WLAN 802.11a 5.2 GHz, Top, Ch 36, 1 Mbps**

**Area Scan (7x15x1):** Measurement grid: dx=10mm, dy=10mm

**Zoom Scan (6x6x9)/Cube 0:** Measurement grid: dx=4.6mm, dy=4.6mm, dz=2.8mm

Reference Value = 4.53 V/m

Peak SAR (extrapolated) = 0.235 W/kg

**SAR(1 g) = 0.072 mW/g; SAR(10 g) = 0.024 mW/g**

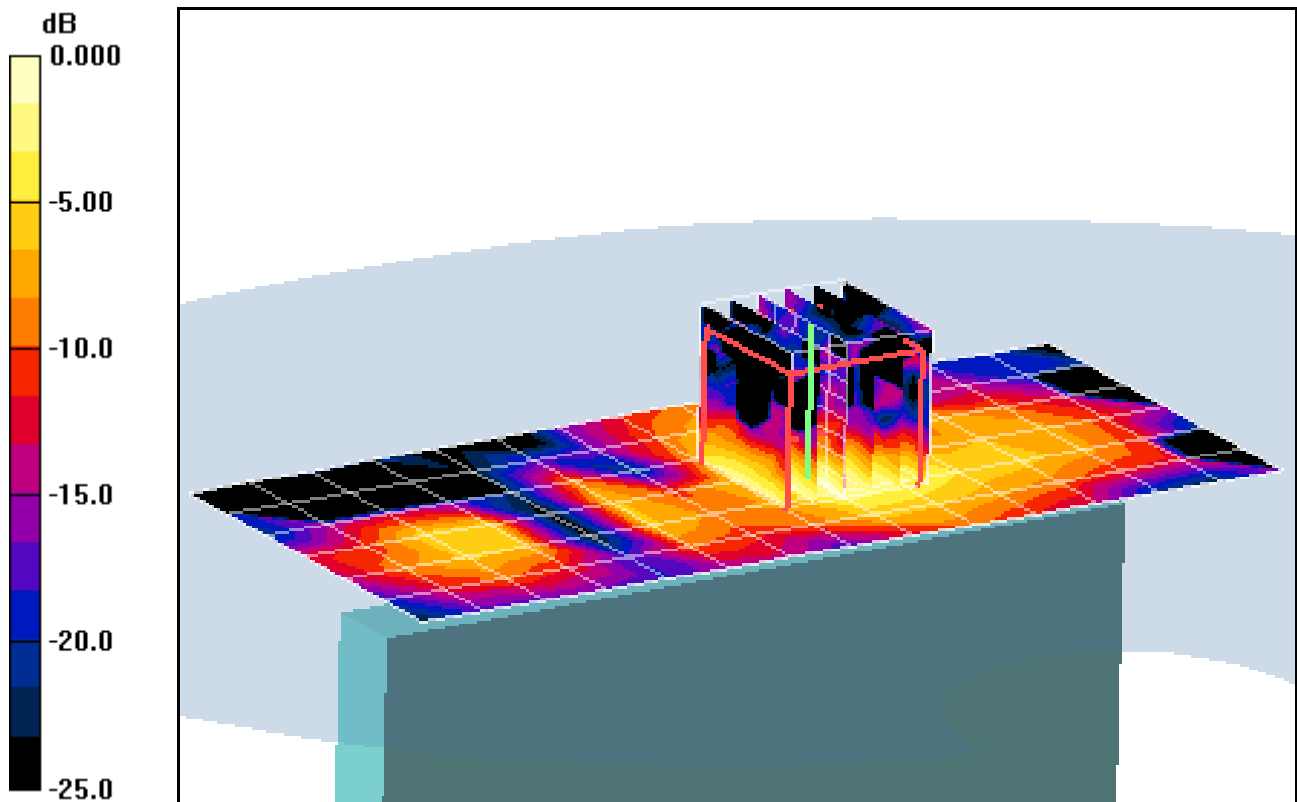

0 dB = 0.141mW/g

# PCTEST ENGINEERING LABORATORY, INC.

**DUT: A3LGTP1010; Type: Mini-Tablet with Bluetooth and WLAN; Serial: FH-218-C**

Communication System: IEEE 802.11a 5.2-5.8 GHz Band; Frequency: 5260 MHz; Duty Cycle: 1:1  
Medium: 5.2 to 5.8 GHz Muscle Medium parameters used (interpolated):

$$f = 5260 \text{ MHz}; \sigma = 5.26 \text{ mho/m}; \epsilon_r = 46.9; \rho = 1000 \text{ kg/m}^3$$

Phantom section: Flat Section; Space: 0.5 cm

Test Date: 09-28-2010; Ambient Temp: 24.3°C; Tissue Temp: 22.4°C

Probe: EX3DV4 - SN3550; ConvF(3.52, 3.52, 3.52); Calibrated: 1/26/2010

Sensor-Surface: 2mm (Mechanical Surface Detection)

Electronics: DAE4 Sn649; Calibrated: 1/22/2010

Phantom: SAM Main; Type: SAM 4.0; Serial: TP-1114

Measurement SW: DASY4, V4.7 Build 80; Postprocessing SW: SEMCAD, V1.8 Build 186

**Mode: WLAN 802.11a 5.3 GHz, Right, Ch 52, 1 Mbps**

**Area Scan (7x22x1):** Measurement grid: dx=10mm, dy=10mm

**Zoom Scan (6x6x9)/Cube 0:** Measurement grid: dx=4.6mm, dy=4.6mm, dz=2.8mm

Reference Value = 0.189 V/m

Peak SAR (extrapolated) = 0.043 W/kg

**SAR(1 g) = 0.00299 mW/g; SAR(10 g) = 0.000478 mW/g**

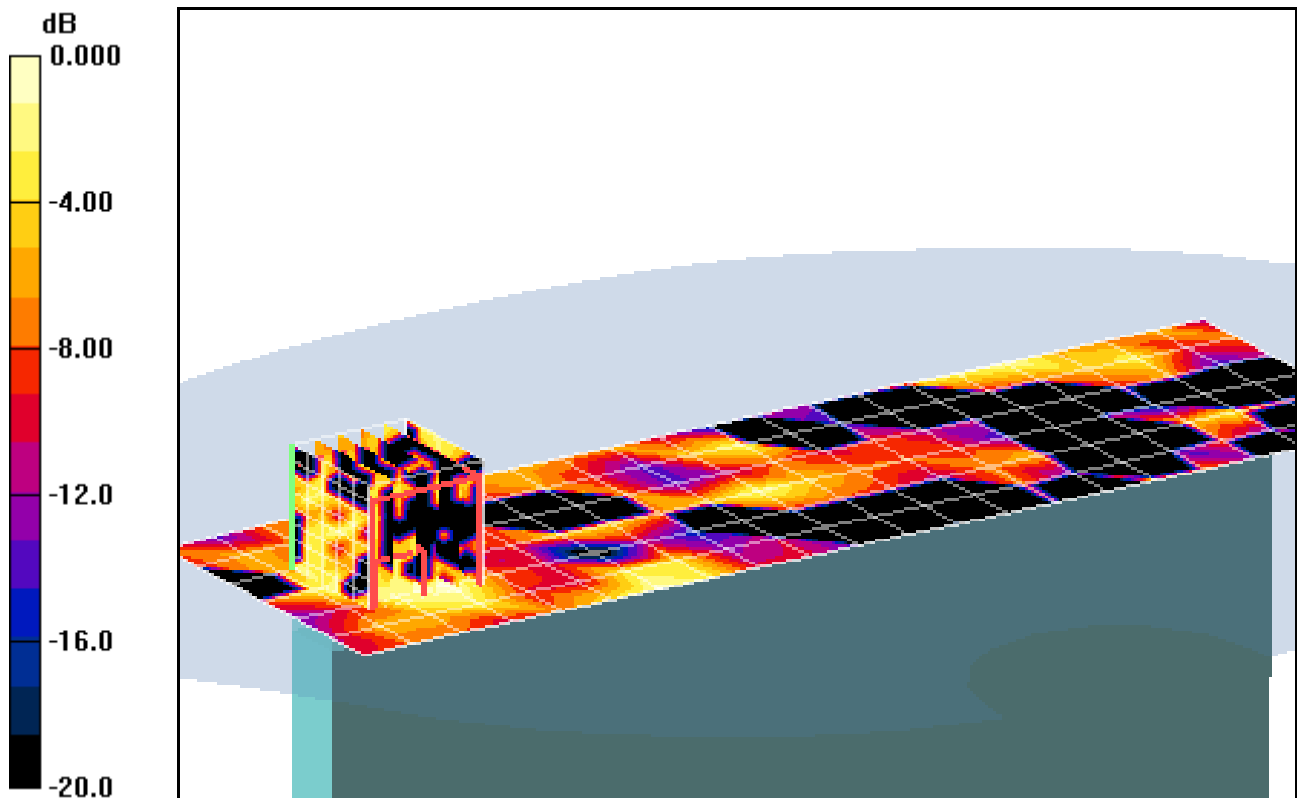

0 dB = 0.060mW/g

# PCTEST ENGINEERING LABORATORY, INC.

**DUT: A3LGTP1010; Type: Mini-Tablet with Bluetooth and WLAN; Serial: FH-218-C**

Communication System: IEEE 802.11a 5.2-5.8 GHz Band; Frequency: 5500 MHz; Duty Cycle: 1:1  
Medium: 5.2 to 5.8 GHz Muscle Medium parameters used (interpolated):

$$f = 5500 \text{ MHz}; \sigma = 5.57 \text{ mho/m}; \epsilon_r = 46.5; \rho = 1000 \text{ kg/m}^3$$

Phantom section: Flat Section; Space: 0.5 cm

Test Date: 09-29-2010; Ambient Temp: 24.5°C; Tissue Temp: 22.6°C

Probe: EX3DV4 - SN3550; ConvF(3.26, 3.26, 3.26); Calibrated: 1/26/2010

Sensor-Surface: 2mm (Mechanical Surface Detection)

Electronics: DAE4 Sn649; Calibrated: 1/22/2010

Phantom: SAM Main; Type: SAM 4.0; Serial: TP-1114

Measurement SW: DASY4, V4.7 Build 80; Postprocessing SW: SEMCAD, V1.8 Build 186

**Mode: WLAN 802.11a 5.5 GHz, Body Back, Ch 100, 1 Mbps**

**Area Scan (16x23x1):** Measurement grid: dx=10mm, dy=10mm

**Zoom Scan (6x6x10)/Cube 0:** Measurement grid: dx=4.4mm, dy=4.4mm, dz=2.5mm

Reference Value = 6.24 V/m

Peak SAR (extrapolated) = 0.513 W/kg

**SAR(1 g) = 0.135 mW/g; SAR(10 g) = 0.041 mW/g**

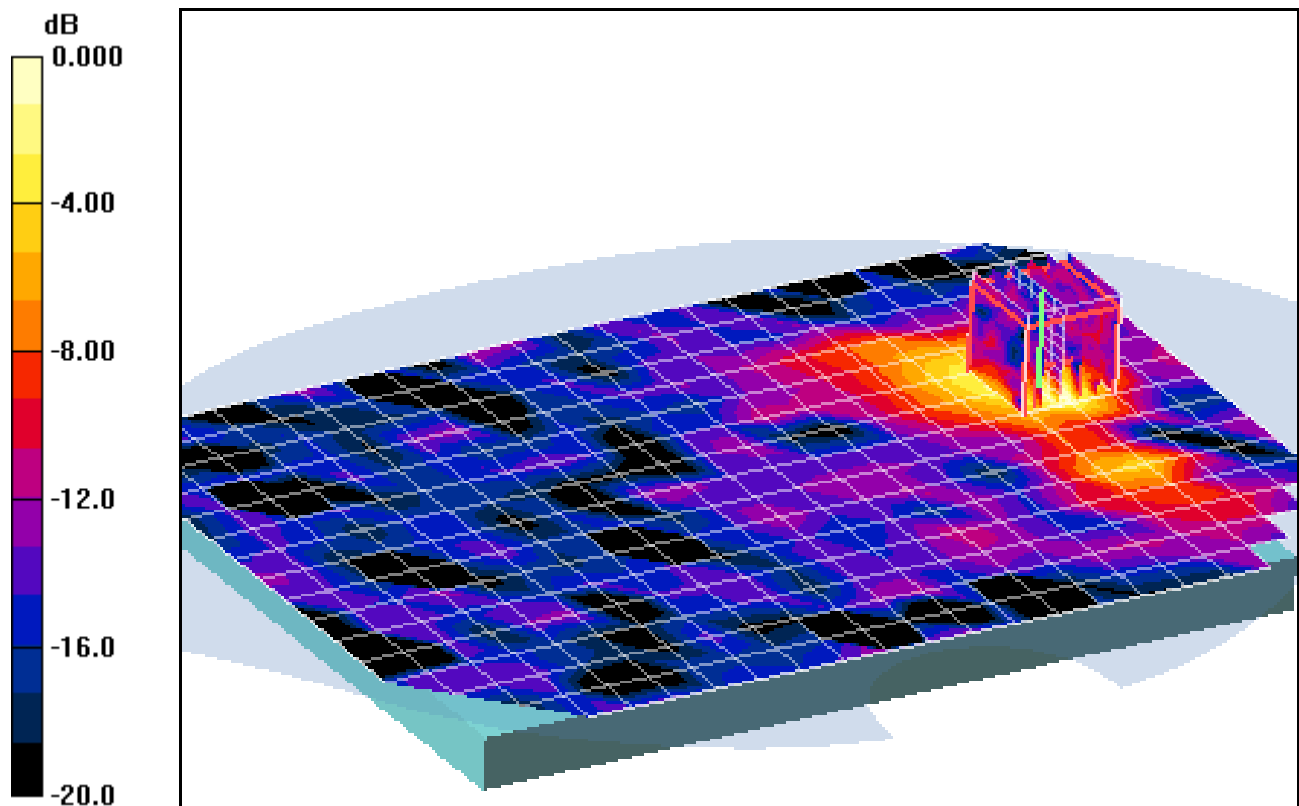

0 dB = 0.299mW/g

# PCTEST ENGINEERING LABORATORY, INC.

**DUT: A3LGTP1010; Type: Mini-Tablet with Bluetooth and WLAN; Serial: FH-218-C**

Communication System: IEEE 802.11a 5.2-5.8 GHz Band; Frequency: 5500 MHz; Duty Cycle: 1:1

Medium: 5.2 to 5.8 GHz Muscle Medium parameters used (interpolated):

$$f = 5500 \text{ MHz}; \sigma = 5.57 \text{ mho/m}; \epsilon_r = 46.5; \rho = 1000 \text{ kg/m}^3$$

Phantom section: Flat Section; Space: 0.5 cm

Test Date: 09-29-2010; Ambient Temp: 24.5°C; Tissue Temp: 22.6°C

Probe: EX3DV4 - SN3550; ConvF(3.26, 3.26, 3.26); Calibrated: 1/26/2010

Sensor-Surface: 2mm (Mechanical Surface Detection)

Electronics: DAE4 Sn649; Calibrated: 1/22/2010

Phantom: SAM Main; Type: SAM 4.0; Serial: TP-1114

Measurement SW: DASY4, V4.7 Build 80; Postprocessing SW: SEMCAD, V1.8 Build 186

**Mode: WLAN 802.11a 5.5 GHz, Top, Ch 100, 54 Mbps**

**Area Scan (7x15x1):** Measurement grid: dx=10mm, dy=10mm

**Zoom Scan (6x6x10)/Cube 0:** Measurement grid: dx=4.4mm, dy=4.4mm, dz=2.5mm

Reference Value = 2.49 V/m

Peak SAR (extrapolated) = 0.225 W/kg

**SAR(1 g) = 0.028 mW/g; SAR(10 g) = 0.00904 mW/g**

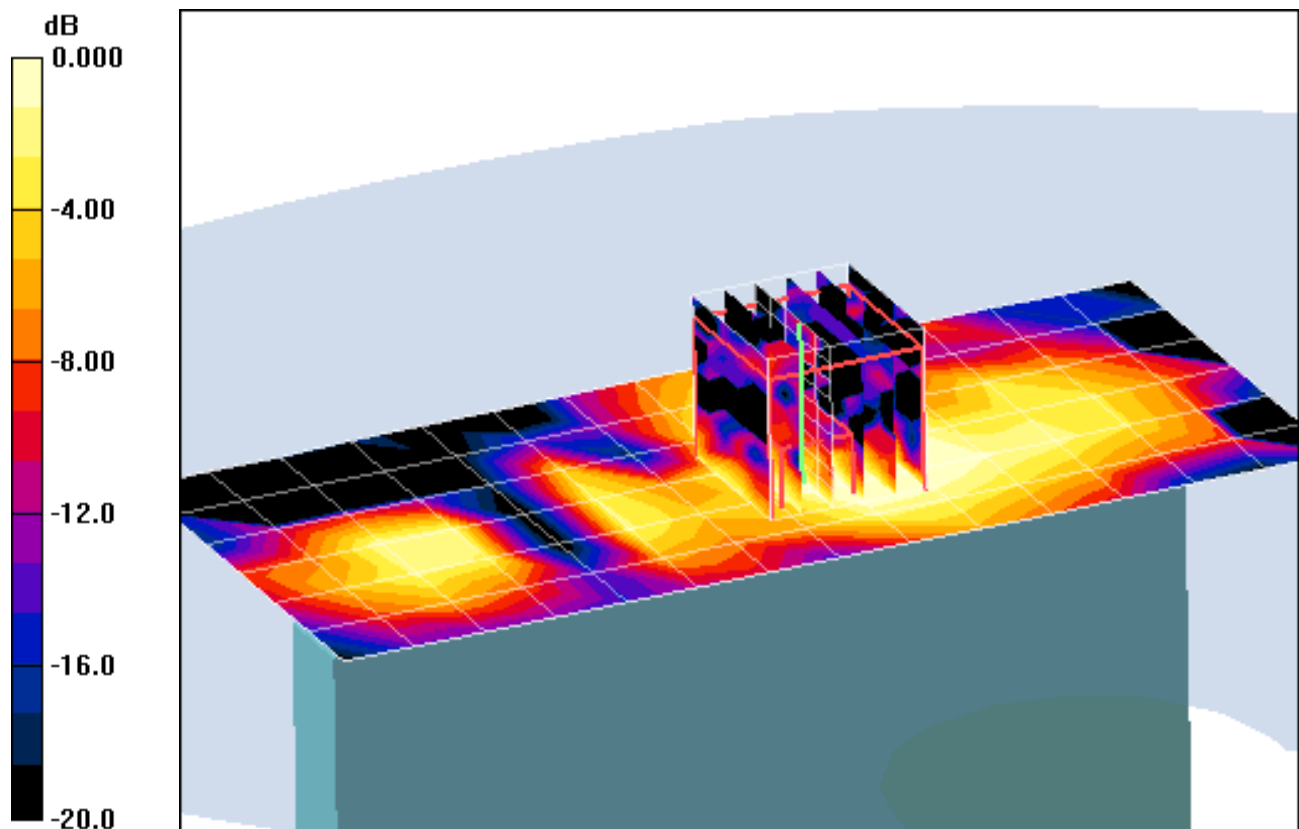

0 dB = 0.059mW/g

# PCTEST ENGINEERING LABORATORY, INC.

**DUT: A3LGTP1010; Type: Mini-Tablet with Bluetooth and WLAN; Serial: FH-218-C**

Communication System: IEEE 802.11a 5.2-5.8 GHz Band; Frequency: 5500 MHz; Duty Cycle: 1:1  
Medium: 5.2 to 5.8 GHz Muscle Medium parameters used (interpolated):

$$f = 5500 \text{ MHz}; \sigma = 5.57 \text{ mho/m}; \epsilon_r = 46.5; \rho = 1000 \text{ kg/m}^3$$

Phantom section: Flat Section; Space: 0.5 cm

Test Date: 09-29-2010; Ambient Temp: 24.5°C; Tissue Temp: 22.6°C

Probe: EX3DV4 - SN3550; ConvF(3.26, 3.26, 3.26); Calibrated: 1/26/2010

Sensor-Surface: 2mm (Mechanical Surface Detection)

Electronics: DAE4 Sn649; Calibrated: 1/22/2010

Phantom: SAM Main; Type: SAM 4.0; Serial: TP-1114

Measurement SW: DASY4, V4.7 Build 80; Postprocessing SW: SEMCAD, V1.8 Build 186

**Mode: WLAN 802.11a 5.5 GHz, Right, Ch 100, 1 Mbps**

**Area Scan (7x22x1):** Measurement grid: dx=10mm, dy=10mm

**Zoom Scan (6x6x9)/Cube 0:** Measurement grid: dx=4.6mm, dy=4.6mm, dz=2.8mm

Reference Value = 0.486 V/m

Peak SAR (extrapolated) = 0.003 W/kg

**SAR(1 g) = 0.000106 mW/g; SAR(10 g) = 1.08e-005 mW/g**

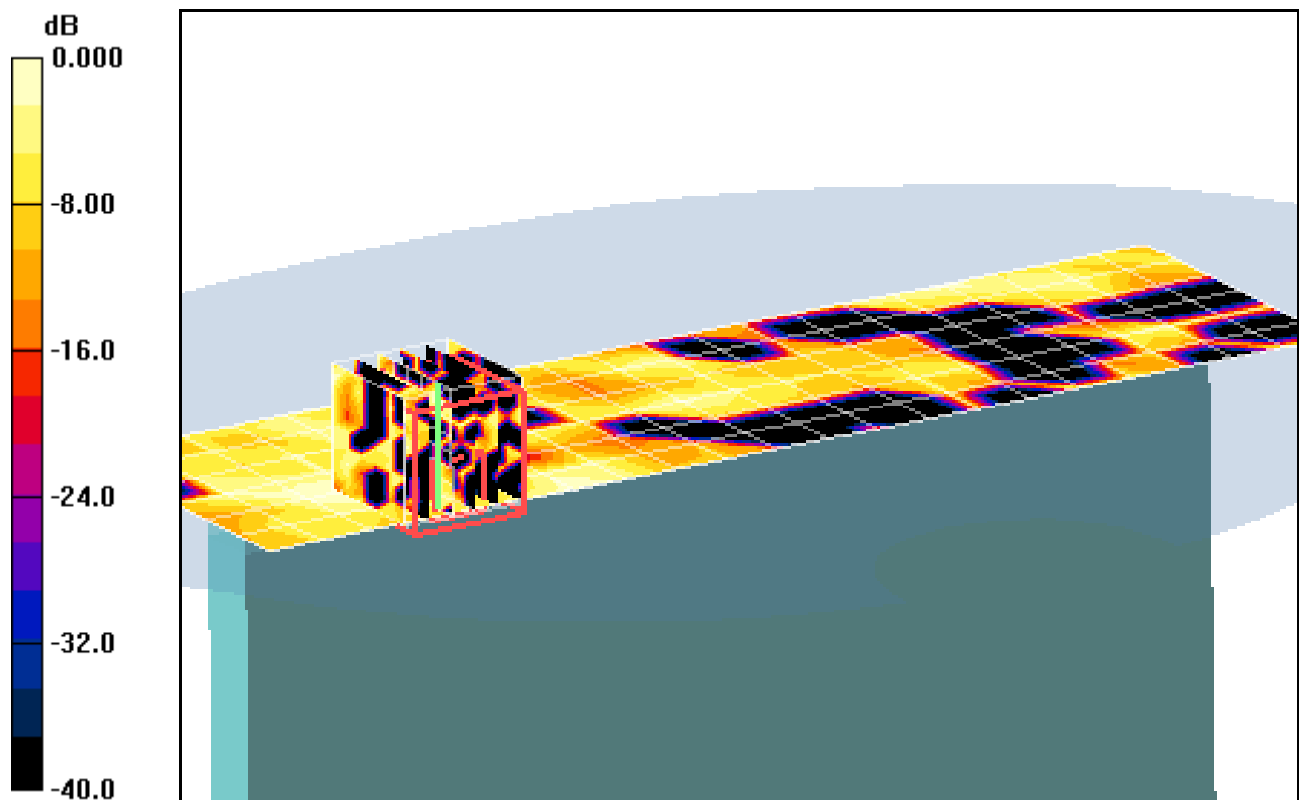

0 dB = 0.060mW/g

# PCTEST ENGINEERING LABORATORY, INC.

**DUT: A3LGTP1010; Type: Mini-Tablet with Bluetooth and WLAN; Serial: FH-218-C**

Communication System: IEEE 802.11a 5.2-5.8 GHz Band; Frequency: 5805 MHz; Duty Cycle: 1:1  
Medium: 5.2 to 5.8 GHz Muscle Medium parameters used (interpolated):

$$f = 5805 \text{ MHz}; \sigma = 5.99 \text{ mho/m}; \epsilon_r = 45.9; \rho = 1000 \text{ kg/m}^3$$

Phantom section: Flat Section; Space: 0.5 cm

Test Date: 09-29-2010; Ambient Temp: 24.6°C; Tissue Temp: 22.7°C

Probe: EX3DV4 - SN3550; ConvF(3.3, 3.3, 3.3); Calibrated: 1/26/2010

Sensor-Surface: 2mm (Mechanical Surface Detection)

Electronics: DAE4 Sn649; Calibrated: 1/22/2010

Phantom: SAM Main; Type: SAM 4.0; Serial: TP-1114

Measurement SW: DASY4, V4.7 Build 80; Postprocessing SW: SEMCAD, V1.8 Build 186

**Mode: WLAN 802.11a 5.8 GHz, Body Back, Ch 161, 1 Mbps**

**Area Scan (16x23x1):** Measurement grid: dx=10mm, dy=10mm

**Zoom Scan (7x7x11)/Cube 0:** Measurement grid: dx=4.1mm, dy=4.1mm, dz=2.2mm

Reference Value = 13.4 V/m

Peak SAR (extrapolated) = 3.53 W/kg

**SAR(1 g) = 0.759 mW/g; SAR(10 g) = 0.207 mW/g**

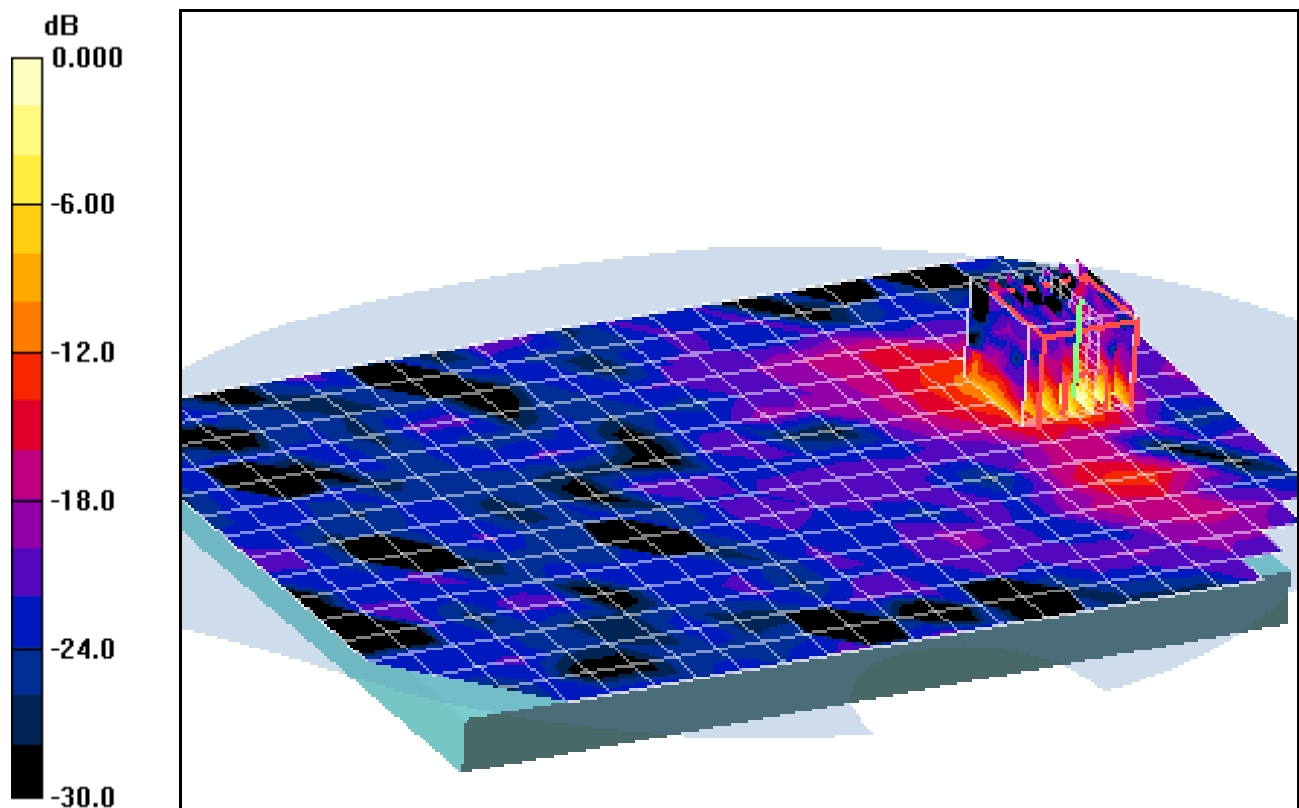

0 dB = 1.91mW/g

# PCTEST ENGINEERING LABORATORY, INC.

**DUT: A3LGTP1010; Type: Mini-Tablet with Bluetooth and WLAN; Serial: FH-218-C**

Communication System: IEEE 802.11a 5.2-5.8 GHz Band; Frequency: 5805 MHz; Duty Cycle: 1:1  
Medium: 5.2 to 5.8 GHz Muscle Medium parameters used (interpolated):

$$f = 5805 \text{ MHz}; \sigma = 5.99 \text{ mho/m}; \epsilon_r = 45.9; \rho = 1000 \text{ kg/m}^3$$

Phantom section: Flat Section; Space: 0.5 cm

Test Date: 09-29-2010; Ambient Temp: 24.6°C; Tissue Temp: 22.7°C

Probe: EX3DV4 - SN3550; ConvF(3.3, 3.3, 3.3); Calibrated: 1/26/2010

Sensor-Surface: 2mm (Mechanical Surface Detection)

Electronics: DAE4 Sn649; Calibrated: 1/22/2010

Phantom: SAM Main; Type: SAM 4.0; Serial: TP-1114

Measurement SW: DASY4, V4.7 Build 80; Postprocessing SW: SEMCAD, V1.8 Build 186

**Mode: WLAN 802.11a 5.8 GHz, Body Back, Ch 161, 1 Mbps**

**Area Scan (16x23x1):** Measurement grid: dx=10mm, dy=10mm

**Zoom Scan (7x7x11)/Cube 0:** Measurement grid: dx=4.1mm, dy=4.1mm, dz=2.2mm

Reference Value = 13.4 V/m

Peak SAR (extrapolated) = 3.53 W/kg

**SAR(1 g) = 0.759 mW/g; SAR(10 g) = 0.207 mW/g**

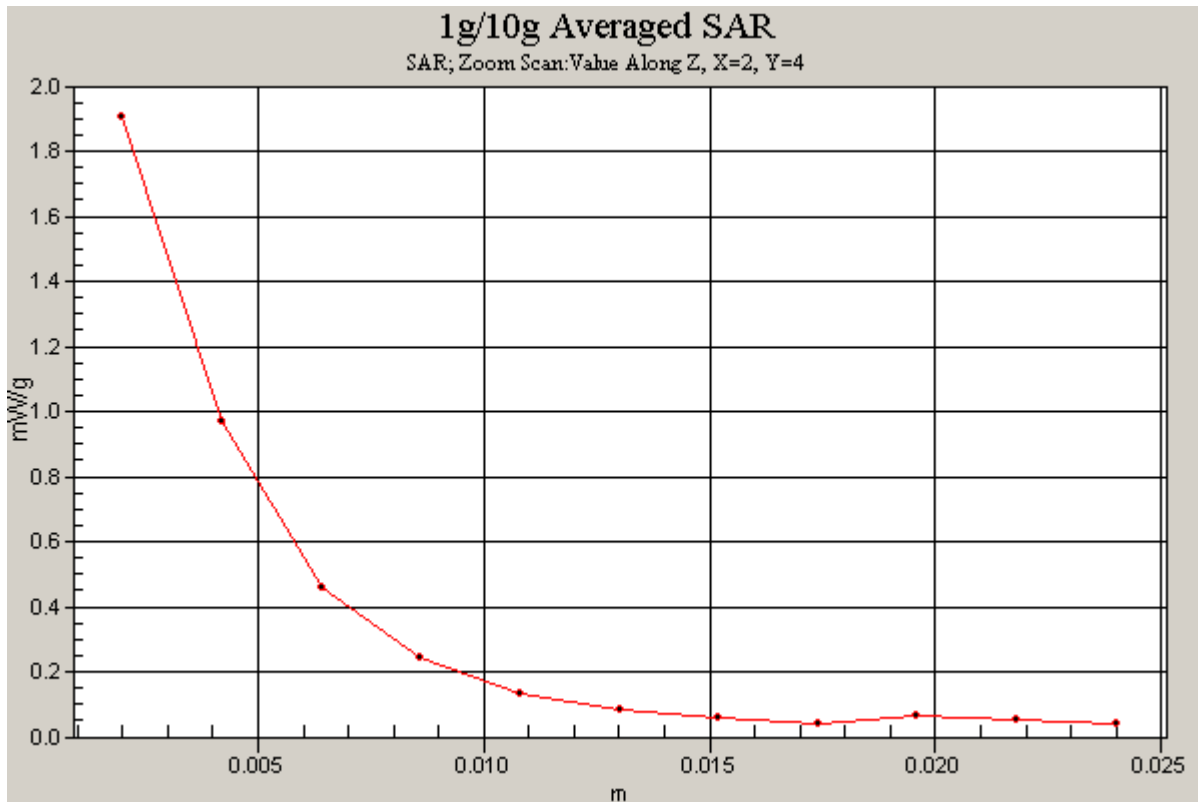

# PCTEST ENGINEERING LABORATORY, INC.

**DUT: A3LGTP1010; Type: Mini-Tablet with Bluetooth and WLAN; Serial: FH-218-C**

Communication System: IEEE 802.11a 5.2-5.8 GHz Band; Frequency: 5805 MHz; Duty Cycle: 1:1

Medium: 5.2 to 5.8 GHz Muscle Medium parameters used (interpolated):

$f = 5805 \text{ MHz}$ ;  $\sigma = 5.99 \text{ mho/m}$ ;  $\epsilon_r = 45.9$ ;  $\rho = 1000 \text{ kg/m}^3$

Phantom section: Flat Section; Space: 0.5 cm

Test Date: 09-29-2010; Ambient Temp: 24.6°C; Tissue Temp: 22.7°C

Probe: EX3DV4 - SN3550; ConvF(3.3, 3.3, 3.3); Calibrated: 1/26/2010

Sensor-Surface: 2mm (Mechanical Surface Detection)

Electronics: DAE4 Sn649; Calibrated: 1/22/2010

Phantom: SAM Main; Type: SAM 4.0; Serial: TP-1114

Measurement SW: DASY4, V4.7 Build 80; Postprocessing SW: SEMCAD, V1.8 Build 186

**Mode: WLAN 802.11a 5.8 GHz, Top, Ch 161, 24 Mbps**

**Area Scan (7x15x1):** Measurement grid: dx=10mm, dy=10mm

**Zoom Scan (7x7x11)/Cube 0:** Measurement grid: dx=4.1mm, dy=4.1mm, dz=2.2mm

Reference Value = 7.14 V/m

Peak SAR (extrapolated) = 0.717 W/kg

**SAR(1 g) = 0.221 mW/g; SAR(10 g) = 0.089 mW/g**

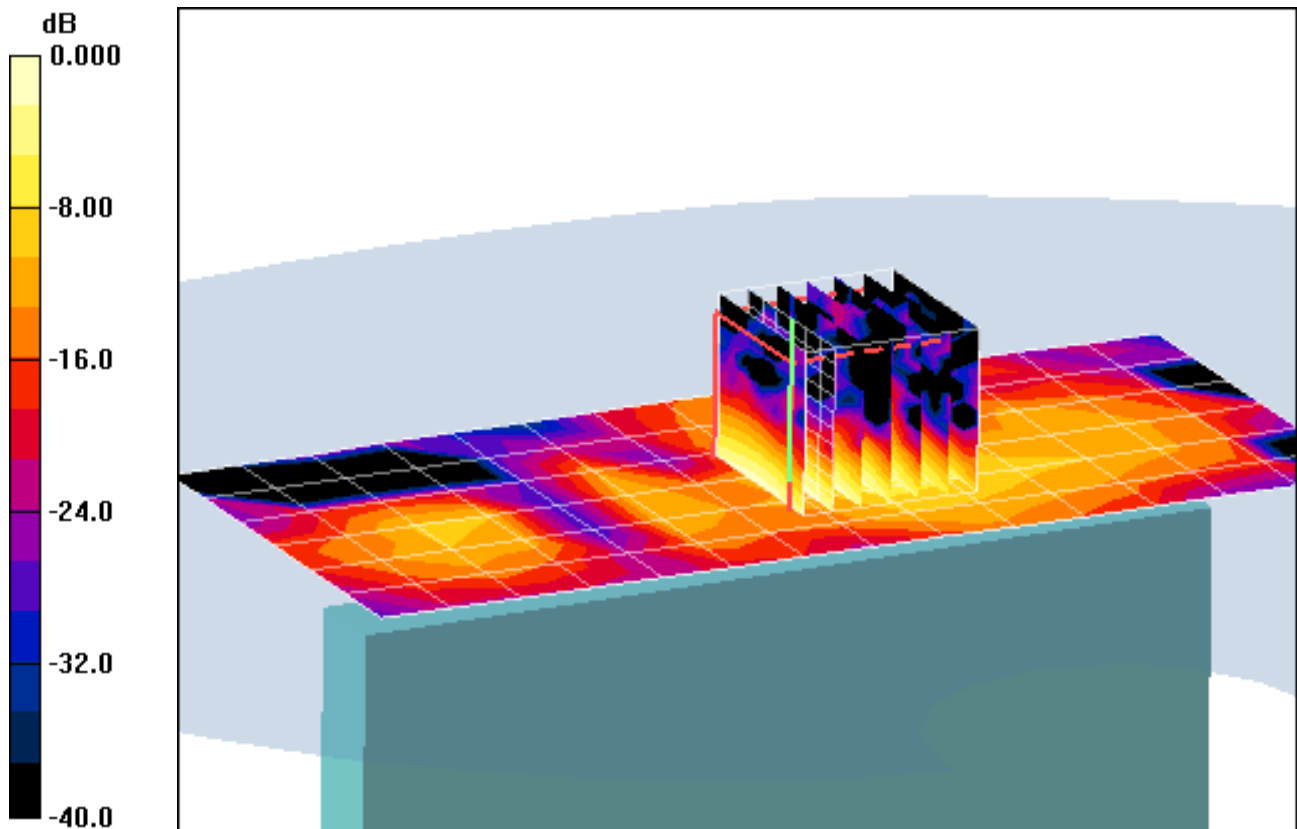

0 dB = 0.416mW/g

# PCTEST ENGINEERING LABORATORY, INC.

**DUT: A3LGTP1010; Type: Mini-Tablet with Bluetooth and WLAN; Serial: FH-218-C**

Communication System: IEEE 802.11a 5.2-5.8 GHz Band; Frequency: 5805 MHz; Duty Cycle: 1:1  
Medium: 5.2 to 5.8 GHz Muscle Medium parameters used (interpolated):

$$f = 5805 \text{ MHz}; \sigma = 5.99 \text{ mho/m}; \epsilon_r = 45.9; \rho = 1000 \text{ kg/m}^3$$

Phantom section: Flat Section; Space: 0.5 cm

Test Date: 09-29-2010; Ambient Temp: 24.6°C; Tissue Temp: 22.7°C

Probe: EX3DV4 - SN3550; ConvF(3.3, 3.3, 3.3); Calibrated: 1/26/2010

Sensor-Surface: 2mm (Mechanical Surface Detection)

Electronics: DAE4 Sn649; Calibrated: 1/22/2010

Phantom: SAM Main; Type: SAM 4.0; Serial: TP-1114

Measurement SW: DASY4, V4.7 Build 80; Postprocessing SW: SEMCAD, V1.8 Build 186

**Mode: WLAN 802.11a 5.8 GHz, Right, Ch 161, 1 Mbps**

**Area Scan (6x22x1):** Measurement grid: dx=10mm, dy=10mm

**Zoom Scan (6x6x9)/Cube 0:** Measurement grid: dx=4.6mm, dy=4.6mm, dz=2.8mm

Reference Value = 1.47 V/m

Peak SAR (extrapolated) = 0.025 W/kg

**SAR(1 g) = 0.000871 mW/g; SAR(10 g) = 9.79e-005 mW/g**

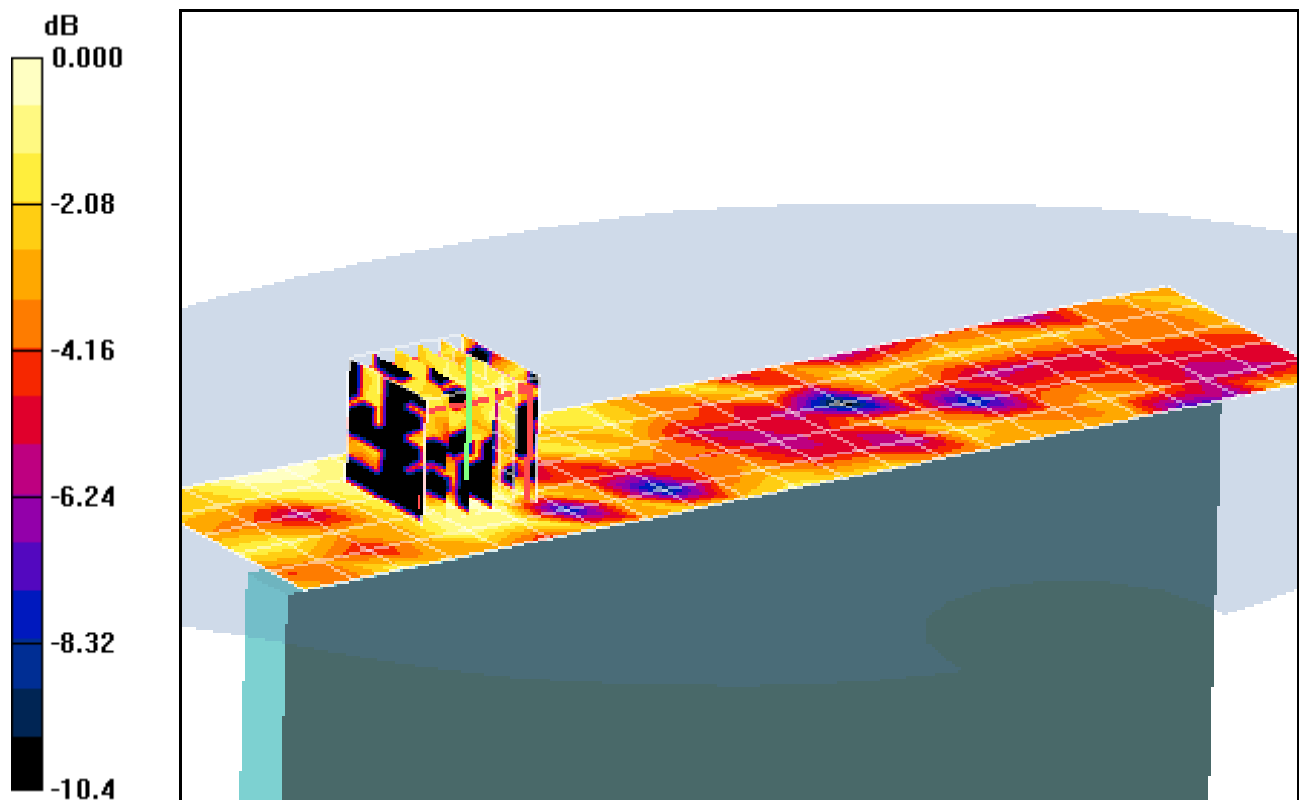

0 dB = 0.034mW/g

## **APPENDIX B: DIPOLE VALIDATION**

# PCTEST ENGINEERING LABORATORY, INC.

**DUT: SAR Dipole 2450 MHz; Type: D2450V2; Serial: 719**

Communication System: CW; Frequency: 2450 MHz; Duty Cycle: 1:1

Medium: 2450 Muscle Medium parameters used:

$f = 2450 \text{ MHz}$ ;  $\sigma = 1.93 \text{ mho/m}$ ;  $\epsilon_r = 50.8$ ;  $\rho = 1000 \text{ kg/m}^3$

Phantom section: Flat Section; Space: 1.0 cm

Test Date: 09-23-2010; Ambient Temp: 24.7°C; Tissue Temp: 23.3°C

Probe: EX3DV4 - SN3550; ConvF(6.4, 6.4, 6.4); Calibrated: 1/26/2010

Sensor-Surface: 4mm (Mechanical Surface Detection)

Electronics: DAE4 Sn649; Calibrated: 1/22/2010

Phantom: SAM Main; Type: SAM 4.0; Serial: TP-1114

Measurement SW: DASY4, V4.7 Build 80; Postprocessing SW: SEMCAD, V1.8 Build 186

## 2450MHz System Verification

**Area Scan (5x7x1):** Measurement grid: dx=15mm, dy=15mm

**Zoom Scan (5x5x7)/Cube 0:** Measurement grid: dx=8mm, dy=8mm, dz=5mm

Input Power = 14 dBm (25 mW)

**SAR(1 g) = 1.27 mW/g; SAR(10 g) = 0.587 mW/g**

Deviation = -1.17 %

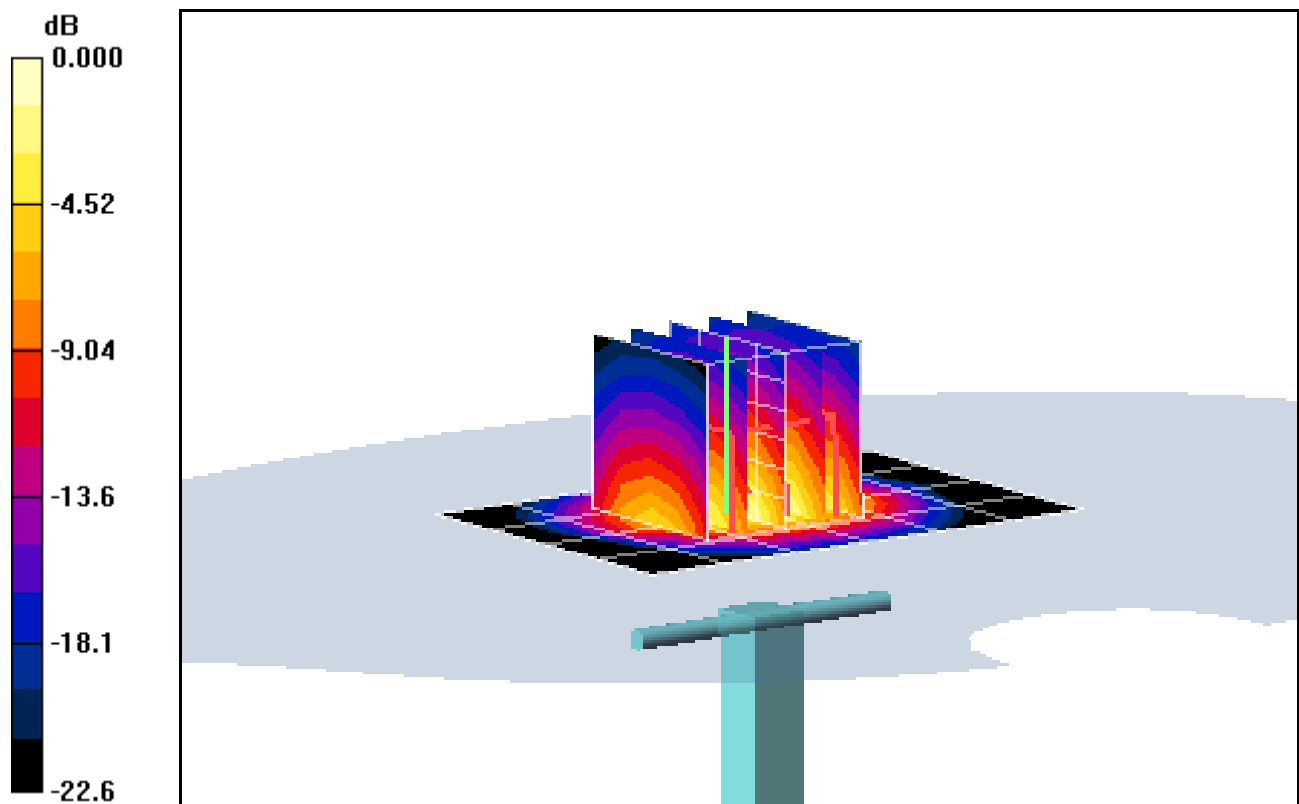

0 dB = 1.25mW/g

# PCTEST ENGINEERING LABORATORY, INC.

**DUT: Dipole 5200 MHz; Type: D5GHzV2; Serial: 1007**

Communication System: CW; Frequency: 5200 MHz; Duty Cycle: 1:1  
Medium: 5.2 to 5.8 GHz Muscle Medium parameters used (interpolated):

$f = 5200 \text{ MHz}$ ;  $\sigma = 5.17 \text{ mho/m}$ ;  $\epsilon_r = 47.1$ ;  $\rho = 1000 \text{ kg/m}^3$

Phantom section: Flat Section; Space: 1.0 cm

Test Date: 09-28-2010; Ambient Temp: 24.3°C; Tissue Temp: 22.4°C

Probe: EX3DV4 - SN3550; ConvF(3.73, 3.73, 3.73); Calibrated: 1/21/2009

Sensor-Surface: 2mm (Mechanical Surface Detection)

Electronics: DAE4 Sn649; Calibrated: 1/22/2010

Phantom: SAM Main; Type: SAM 4.0; Serial: TP-1114

Measurement SW: DASY4, V4.7 Build 80; Postprocessing SW: SEMCAD, V1.8 Build 186

## 5200MHz System Verification

**Area Scan (7x9x1):** Measurement grid: dx=10mm, dy=10mm

**Zoom Scan (8x8x8)/Cube 0:** Measurement grid: dx=4.3mm, dy=4.3mm, dz=3mm

Input Power = 14 dBm (25 mW)

**SAR(1 g) = 1.87 mW/g; SAR(10 g) = 0.512 mW/g**

Deviation = -5.20 %

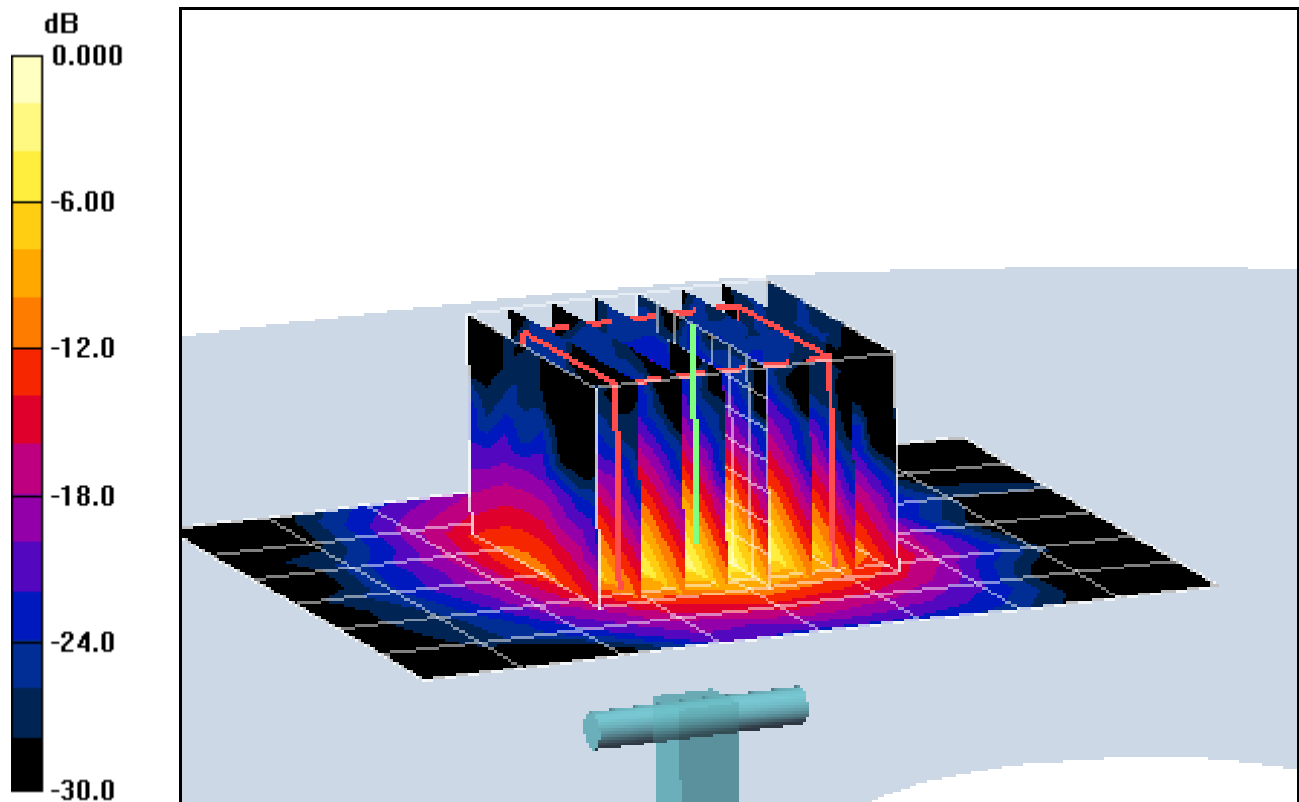

0 dB = 3.55mW/g

# PCTEST ENGINEERING LABORATORY, INC.

**DUT: Dipole 5500 MHz; Type: D5GHzV2; Serial: 1007**

Communication System: CW; Frequency: 5500 MHz; Duty Cycle: 1:1  
Medium: 5.2 to 5.8 GHz Muscle Medium parameters used (interpolated):

$f = 5500 \text{ MHz}$ ;  $\sigma = 5.57 \text{ mho/m}$ ;  $\epsilon_r = 46.5$ ;  $\rho = 1000 \text{ kg/m}^3$

Phantom section: Flat Section; Space: 1.0 cm

Test Date: 09-29-2010; Ambient Temp: 24.5°C; Tissue Temp: 22.6°C

Probe: EX3DV4 - SN3550; ConvF(3.26, 3.26, 3.26); Calibrated: 1/21/2009

Sensor-Surface: 2mm (Mechanical Surface Detection)

Electronics: DAE4 Sn649; Calibrated: 1/22/2010

Phantom: SAM Main; Type: SAM 4.0; Serial: TP-1114

Measurement SW: DASY4, V4.7 Build 80; Postprocessing SW: SEMCAD, V1.8 Build 186

## 5500MHz System Verification

**Area Scan (7x9x1):** Measurement grid: dx=10mm, dy=10mm

**Zoom Scan (6x6x10)/Cube 0:** Measurement grid: dx=4.4mm, dy=4.4mm, dz=2.5mm

Input Power = 14 dBm (25 mW)

**SAR(1 g) = 2.16 mW/g; SAR(10 g) = 0.570 mW/g**

Deviation = 2.73 %

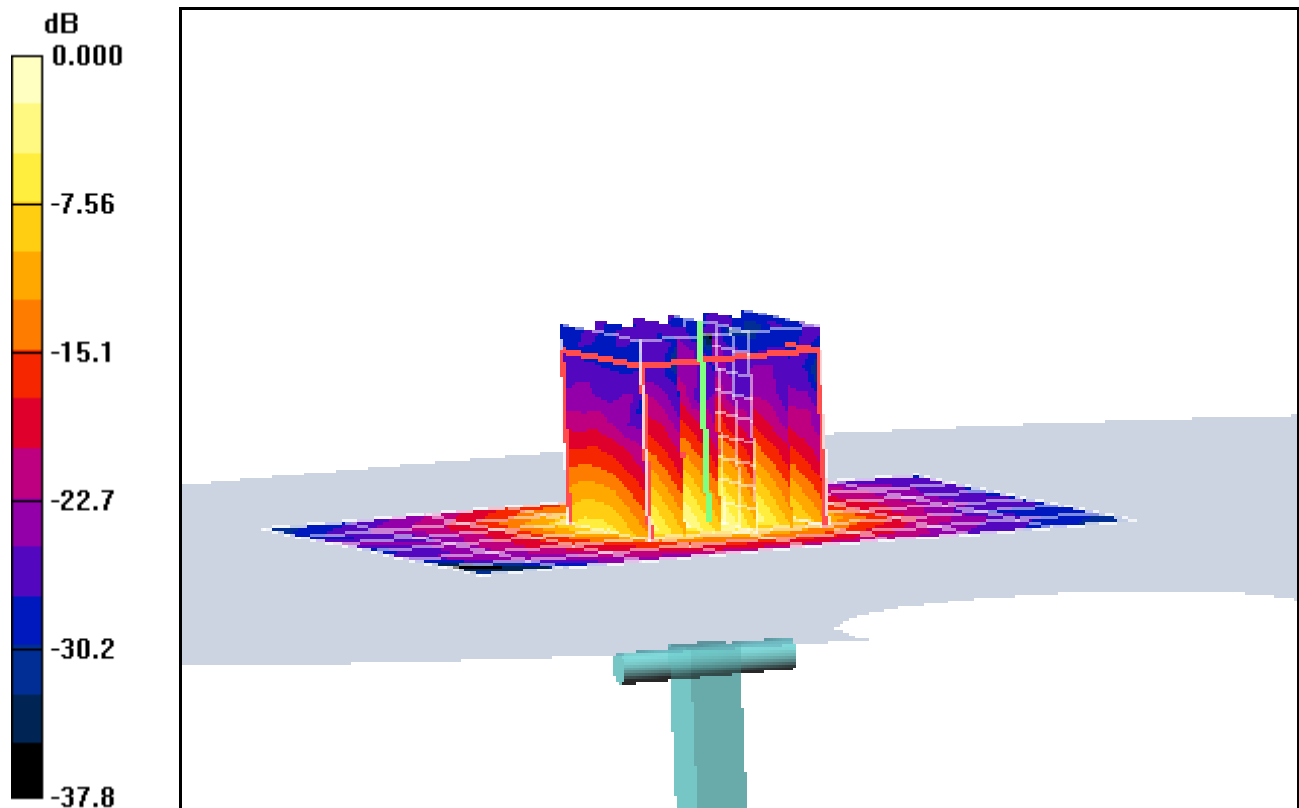

0 dB = 4.28mW/g

# PCTEST ENGINEERING LABORATORY, INC.

**DUT: Dipole 5800 MHz; Type: D5GHzV2; Serial: 1007**

Communication System: CW; Frequency: 5800 MHz; Duty Cycle: 1:1  
Medium: 5.2 to 5.8 GHz Muscle Medium parameters used (interpolated):

$f = 5800 \text{ MHz}$ ;  $\sigma = 5.98 \text{ mho/m}$ ;  $\epsilon_r = 45.9$ ;  $\rho = 1000 \text{ kg/m}^3$

Phantom section: Flat Section; Space: 1.0 cm

Test Date: 09-29-2010; Ambient Temp: 24.6°C; Tissue Temp: 22.7°C

Probe: EX3DV4 - SN3550; ConvF(3.3, 3.3, 3.3); Calibrated: 1/26/2010

Sensor-Surface: 2mm (Mechanical Surface Detection)

Electronics: DAE4 Sn649; Calibrated: 1/22/2010

Phantom: SAM Main; Type: SAM 4.0; Serial: TP-1114

Measurement SW: DASY4, V4.7 Build 80; Postprocessing SW: SEMCAD, V1.8 Build 186

## 5800MHz System Verification

**Area Scan (7x9x1):** Measurement grid: dx=10mm, dy=10mm

**Zoom Scan (7x7x11)/Cube 0:** Measurement grid: dx=4.1mm, dy=4.1mm, dz=2.2mm

Input Power = 14 dBm (25 mW)

**SAR(1 g) = 1.89 mW/g; SAR(10 g) = 0.524 mW/g**

Deviation = 4.56 %

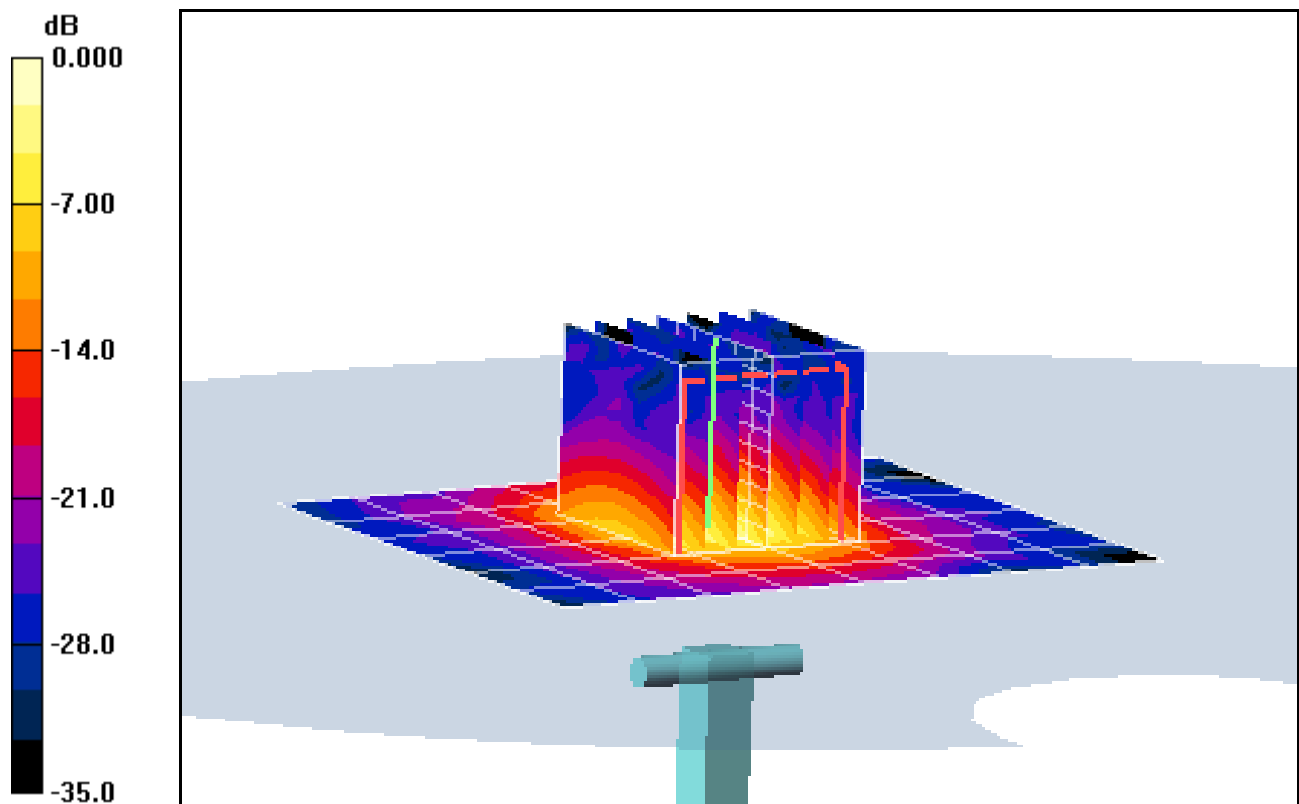

0 dB = 4.13mW/g

## **APPENDIX C: PROBE CALIBRATION**



Accredited by the Swiss Accreditation Service (SAS)  
The Swiss Accreditation Service is one of the signatories to the EA  
Multilateral Agreement for the recognition of calibration certificates

Accreditation No.: SCS 108

Client **PC Test**

Certificate No: **EX3-3550\_Jan10**

**CALIBRATION CERTIFICATE**

Object **EX3DV4 - SN:3550**

Calibration procedure(s) **QA CAL-01.v6, QA CAL-14.v3, QA CAL-23.v3 and QA CAL-25.v2  
Calibration procedure for dosimetric E-field probes**

Calibration date: **January 26, 2010**

*✓*  
*1/26/10*

This calibration certificate documents the traceability to national standards, which realize the physical units of measurements (SI).  
The measurements and the uncertainties with confidence probability are given on the following pages and are part of the certificate.

All calibrations have been conducted in the closed laboratory facility: environment temperature (22 ± 3)°C and humidity < 70%.

Calibration Equipment used (M&TE critical for calibration)

Primary Standards	ID #	Cal Date (Certificate No.)	Scheduled Calibration
Power meter E4419B	GB41293874	1-Apr-09 (No. 217-01030)	Apr-10
Power sensor E4412A	MY41495277	1-Apr-09 (No. 217-01030)	Apr-10
Power sensor E4412A	MY41498087	1-Apr-09 (No. 217-01030)	Apr-10
Reference 3 dB Attenuator	SN: S5054 (3c)	31-Mar-09 (No. 217-01026)	Mar-10
Reference 20 dB Attenuator	SN: S5086 (20b)	31-Mar-09 (No. 217-01028)	Mar-10
Reference 30 dB Attenuator	SN: S5129 (30b)	31-Mar-09 (No. 217-01027)	Mar-10
Reference Probe ES3DV2	SN: 3013	30-Dec-09 (No. ES3-3013_Dec09)	Dec-10
DAE4	SN: 660	29-Sep-09 (No. DAE4-660_Sep09)	Sep-10
Secondary Standards	ID #	Check Date (in house)	Scheduled Check
RF generator HP 8648C	US3642U01700	4-Aug-99 (in house check Oct-09)	In house check: Oct-11
Network Analyzer HP 8753E	US37390585	18-Oct-01 (in house check Oct-09)	In house check: Oct10

Calibrated by:	Name <b>Katja Pokovic</b>	Function <b>Technical Manager</b>	Signature 
Approved by:	Name <b>Fin Bornholt</b>	Function <b>R&amp;D Director</b>	Signature 

Issued: January 26, 2010

This calibration certificate shall not be reproduced except in full without written approval of the laboratory.



Accredited by the Swiss Accreditation Service (SAS)  
The Swiss Accreditation Service is one of the signatories to the EA  
Multilateral Agreement for the recognition of calibration certificates

Accreditation No.: **SCS 108**

### Glossary:

TSL	tissue simulating liquid
NORM <sub>x,y,z</sub>	sensitivity in free space
ConvF	sensitivity in TSL / NORM <sub>x,y,z</sub>
DCP	diode compression point
CF	crest factor (1/duty_cycle) of the RF signal
A, B, C	modulation dependent linearization parameters
Polarization $\varphi$	$\varphi$ rotation around probe axis
Polarization $\vartheta$	$\vartheta$ rotation around an axis that is in the plane normal to probe axis (at measurement center), i.e., $\vartheta = 0$ is normal to probe axis

### Calibration is Performed According to the Following Standards:

- IEEE Std 1528-2003, "IEEE Recommended Practice for Determining the Peak Spatial-Averaged Specific Absorption Rate (SAR) in the Human Head from Wireless Communications Devices: Measurement Techniques", December 2003
- IEC 62209-1, "Procedure to measure the Specific Absorption Rate (SAR) for hand-held devices used in close proximity to the ear (frequency range of 300 MHz to 3 GHz)", February 2005

### Methods Applied and Interpretation of Parameters:

- NORM<sub>x,y,z</sub>**: Assessed for E-field polarization  $\vartheta = 0$  ( $f \leq 900$  MHz in TEM-cell;  $f > 1800$  MHz: R22 waveguide). NORM<sub>x,y,z</sub> are only intermediate values, i.e., the uncertainties of NORM<sub>x,y,z</sub> does not effect the  $E^2$ -field uncertainty inside TSL (see below ConvF).
- NORM(f)<sub>x,y,z</sub>** = NORM<sub>x,y,z</sub> \* frequency\_response (see Frequency Response Chart). This linearization is implemented in DASY4 software versions later than 4.2. The uncertainty of the frequency response is included in the stated uncertainty of ConvF.
- DCP<sub>x,y,z</sub>**: DCP are numerical linearization parameters assessed based on the data of power sweep with CW signal (no uncertainty required). DCP does not depend on frequency nor media.
- A<sub>x,y,z</sub>; B<sub>x,y,z</sub>; C<sub>x,y,z</sub>; VR<sub>x,y,z</sub>**: A, B, C are numerical linearization parameters assessed based on the data of power sweep for specific modulation signal. The parameters do not depend on frequency nor media. VR is the maximum calibration range expressed in RMS voltage across the diode.
- ConvF and Boundary Effect Parameters**: Assessed in flat phantom using E-field (or Temperature Transfer Standard for  $f \leq 800$  MHz) and inside waveguide using analytical field distributions based on power measurements for  $f > 800$  MHz. The same setups are used for assessment of the parameters applied for boundary compensation (alpha, depth) of which typical uncertainty values are given. These parameters are used in DASY4 software to improve probe accuracy close to the boundary. The sensitivity in TSL corresponds to NORM<sub>x,y,z</sub> \* ConvF whereby the uncertainty corresponds to that given for ConvF. A frequency dependent ConvF is used in DASY version 4.4 and higher which allows extending the validity from  $\pm 50$  MHz to  $\pm 100$  MHz.
- Spherical isotropy (3D deviation from isotropy)**: in a field of low gradients realized using a flat phantom exposed by a patch antenna.
- Sensor Offset**: The sensor offset corresponds to the offset of virtual measurement center from the probe tip (on probe axis). No tolerance required.

# Probe EX3DV4

## SN:3550

Manufactured:	May 19, 2004
Last calibrated:	January 21, 2009
Recalibrated:	January 26, 2010

Calibrated for DASYS Systems

(Note: non-compatible with DASYS2 system!)

**DASY - Parameters of Probe: EX3DV4 SN:3550****Basic Calibration Parameters**

	Sensor X	Sensor Y	Sensor Z	Unc (k=2)
Norm ( $\mu\text{V}/(\text{V}/\text{m})^2$ ) <sup>A</sup>	0.48	0.47	0.48	± 10.1%
DCP (mV) <sup>B</sup>	92.9	88.4	91.4	

**Modulation Calibration Parameters**

UID	Communication System Name	PAR		A dB	B dBuV	C	VR mV	Unc <sup>E</sup> (k=2)
10000	CW	0.00	X	0.00	0.00	1.00	300	± 1.5%
			Y	0.00	0.00	1.00	300	
			Z	0.00	0.00	1.00	300	

The reported uncertainty of measurement is stated as the standard uncertainty of measurement multiplied by the coverage factor k=2, which for a normal distribution corresponds to a coverage probability of approximately 95%.

<sup>A</sup> The uncertainties of NormX,Y,Z do not affect the E<sup>2</sup>-field uncertainty inside TSL (see Pages 5 and 6).

<sup>B</sup> Numerical linearization parameter: uncertainty not required.

<sup>E</sup> Uncertainty is determined using the maximum deviation from linear response applying rectangular distribution and is expressed for the square of the field value.

## DASY - Parameters of Probe: EX3DV4 SN:3550

### Calibration Parameter Determined in Head Tissue Simulating Media

f [MHz]	Validity [MHz] <sup>c</sup>	Permittivity	Conductivity	ConvF X	ConvF Y	ConvF Z	Alpha	Depth Unc (k=2)
835	± 50 / ± 100	41.5 ± 5%	0.90 ± 5%	8.28	8.28	8.28	0.45	0.70 ± 11.0%
1750	± 50 / ± 100	40.1 ± 5%	1.37 ± 5%	7.03	7.03	7.03	0.39	0.75 ± 11.0%
1900	± 50 / ± 100	40.0 ± 5%	1.40 ± 5%	6.81	6.81	6.81	0.32	0.81 ± 11.0%
2450	± 50 / ± 100	39.2 ± 5%	1.80 ± 5%	6.21	6.21	6.21	0.22	1.07 ± 11.0%

<sup>c</sup> The validity of ± 100 MHz only applies for DASY v4.4 and higher (see Page 2). The uncertainty is the RSS of the ConvF uncertainty at calibration frequency and the uncertainty for the indicated frequency band.

## DASY - Parameters of Probe: EX3DV4 SN:3550

### Calibration Parameter Determined in Body Tissue Simulating Media

f [MHz]	Validity [MHz] <sup>c</sup>	Permittivity	Conductivity	ConvF X	ConvF Y	ConvF Z	Alpha	Depth Unc (k=2)
835	± 50 / ± 100	55.2 ± 5%	0.97 ± 5%	8.30	8.30	8.30	0.47	0.76 ± 11.0%
1750	± 50 / ± 100	53.4 ± 5%	1.49 ± 5%	6.90	6.90	6.90	0.49	0.69 ± 11.0%
1900	± 50 / ± 100	53.3 ± 5%	1.52 ± 5%	6.63	6.63	6.63	0.76	0.54 ± 11.0%
2450	± 50 / ± 100	52.7 ± 5%	1.95 ± 5%	6.40	6.40	6.40	0.22	1.09 ± 11.0%
2600	± 50 / ± 100	52.5 ± 5%	2.16 ± 5%	6.26	6.26	6.26	0.19	1.42 ± 11.0%
4950	± 50 / ± 100	49.4 ± 5%	5.01 ± 5%	3.64	3.64	3.64	0.50	1.75 ± 13.1%
5200	± 50 / ± 100	49.0 ± 5%	5.30 ± 5%	3.73	3.73	3.73	0.50	1.75 ± 13.1%
5300	± 50 / ± 100	48.5 ± 5%	5.42 ± 5%	3.52	3.52	3.52	0.52	1.75 ± 13.1%
5500	± 50 / ± 100	48.6 ± 5%	5.65 ± 5%	3.26	3.26	3.26	0.55	1.80 ± 13.1%
5600	± 50 / ± 100	48.5 ± 5%	5.77 ± 5%	3.16	3.16	3.16	0.65	1.80 ± 13.1%
5800	± 50 / ± 100	48.2 ± 5%	6.00 ± 5%	3.30	3.30	3.30	0.60	1.75 ± 13.1%

<sup>c</sup> The validity of ± 100 MHz only applies for DASY v4.4 and higher (see Page 2). The uncertainty is the RSS of the ConvF uncertainty at calibration frequency and the uncertainty for the indicated frequency band.

# Frequency Response of E-Field

(TEM-Cell:ifi110 EXX, Waveguide: R22)

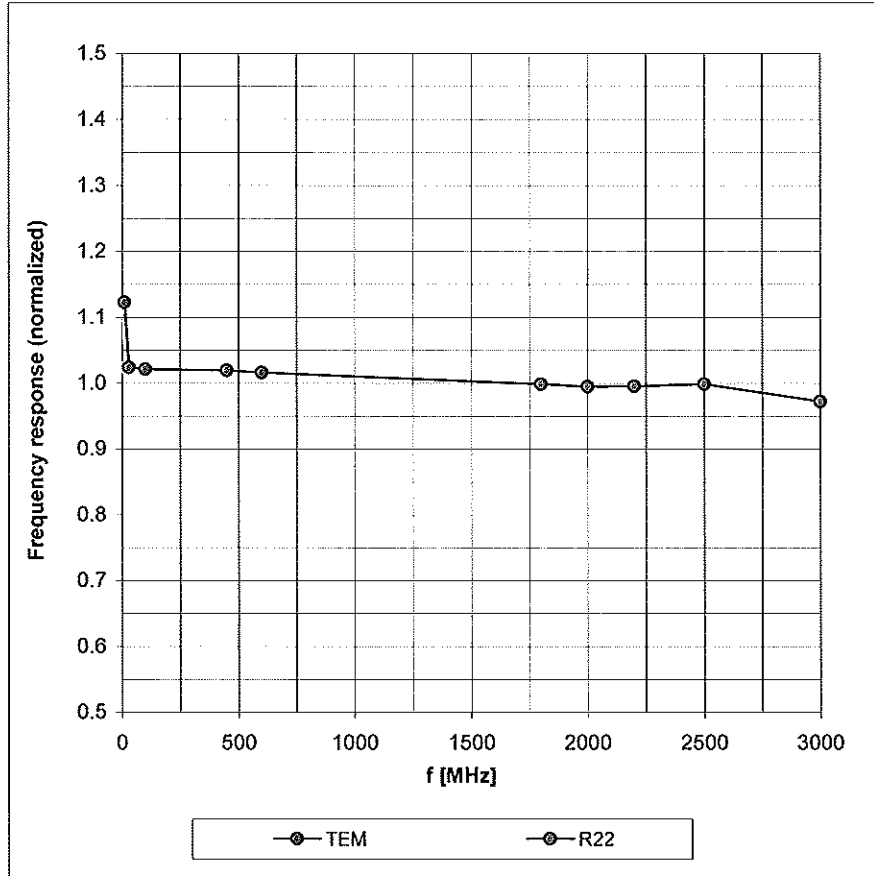

Uncertainty of Frequency Response of E-field:  $\pm 6.3\%$  (k=2)

### Receiving Pattern ( $\phi$ ), $\vartheta = 0^\circ$

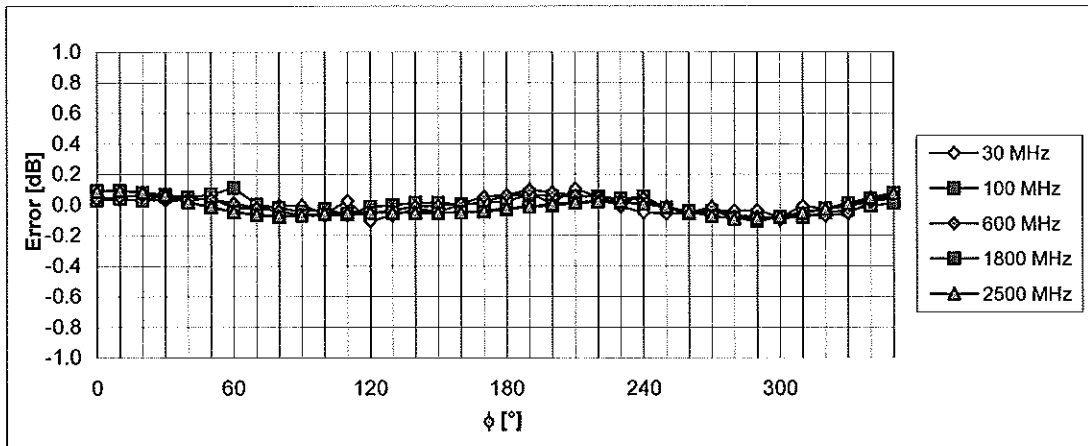
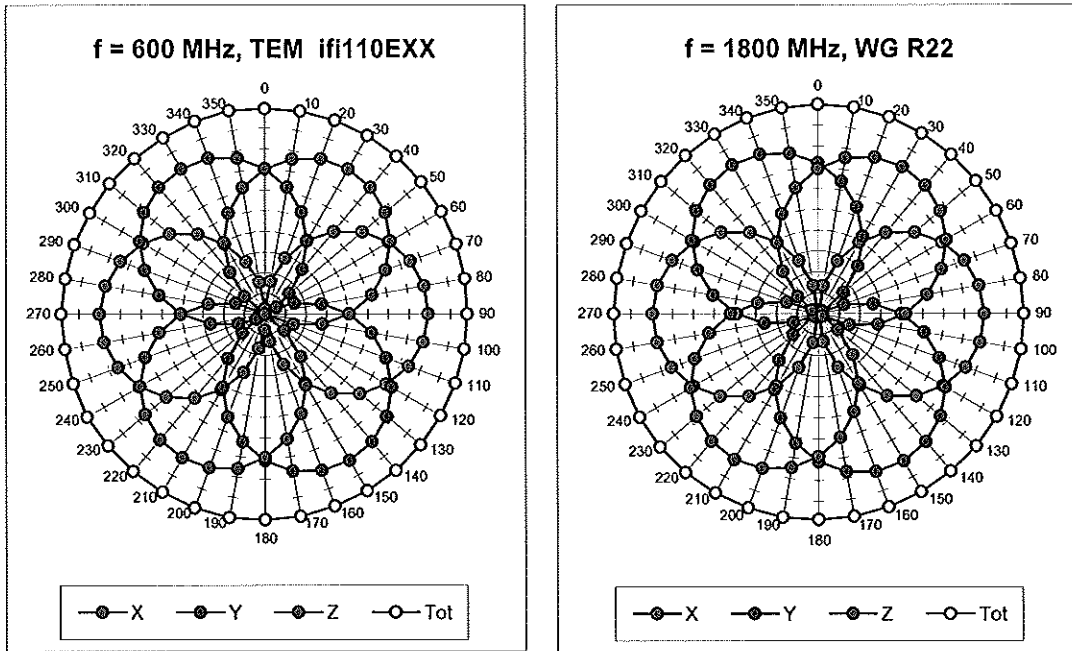

Uncertainty of Axial Isotropy Assessment:  $\pm 0.5\%$  ( $k=2$ )

### Dynamic Range f(SAR<sub>head</sub>) (Waveguide R22, f = 1800 MHz)

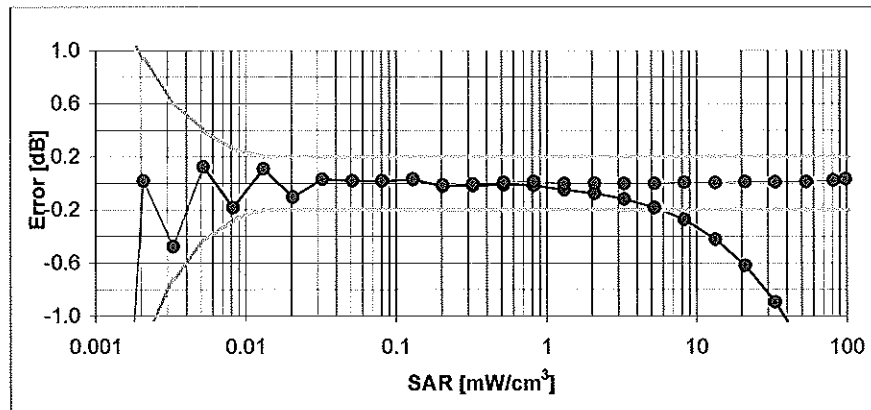
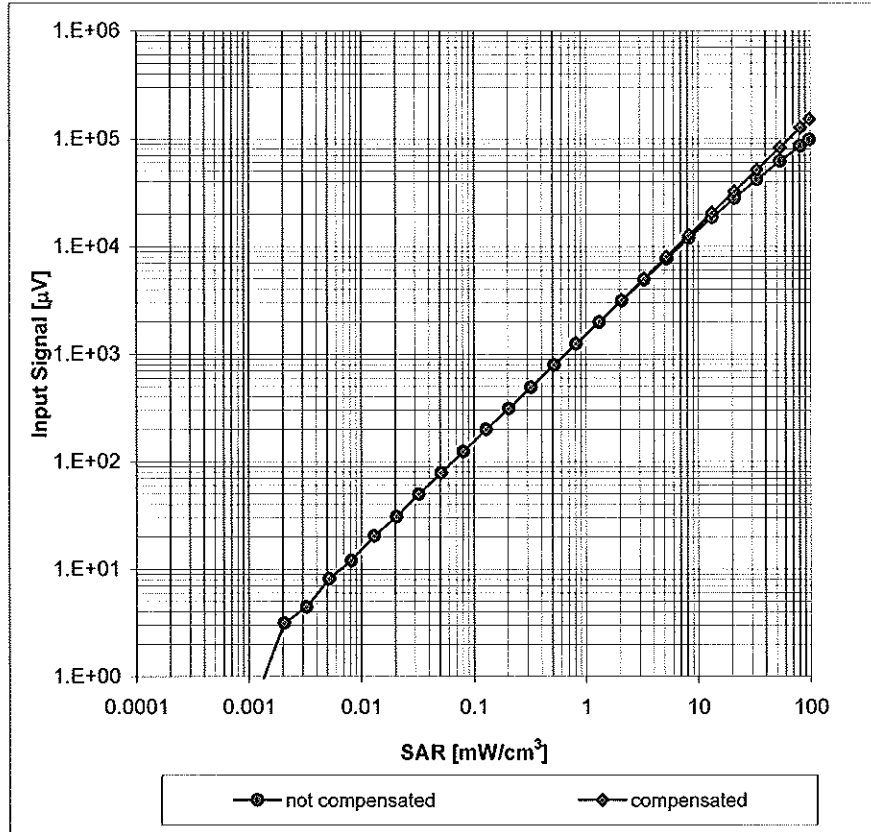

Uncertainty of Linearity Assessment: ± 0.6% (k=2)

### Conversion Factor Assessment

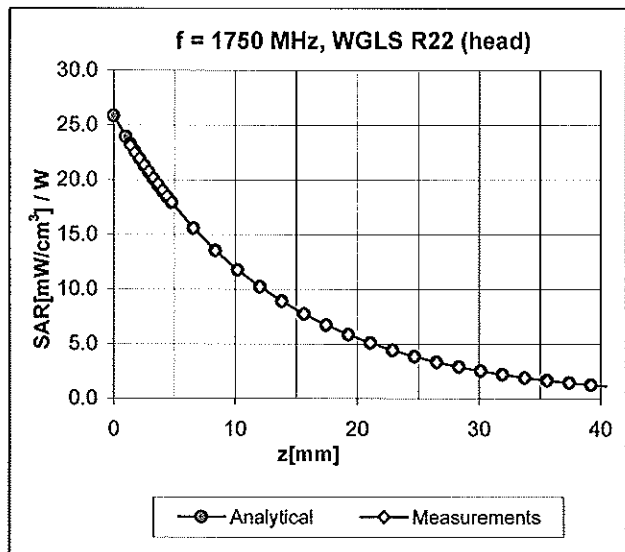
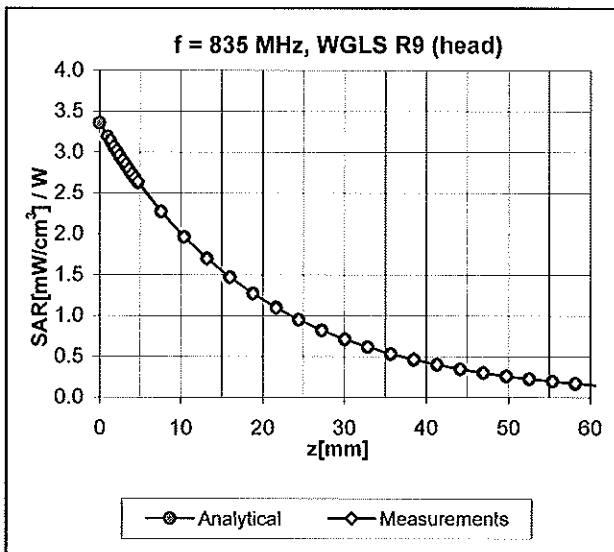

### Deviation from Isotropy in HSL

Error ( $\phi, \theta$ ), f = 900 MHz

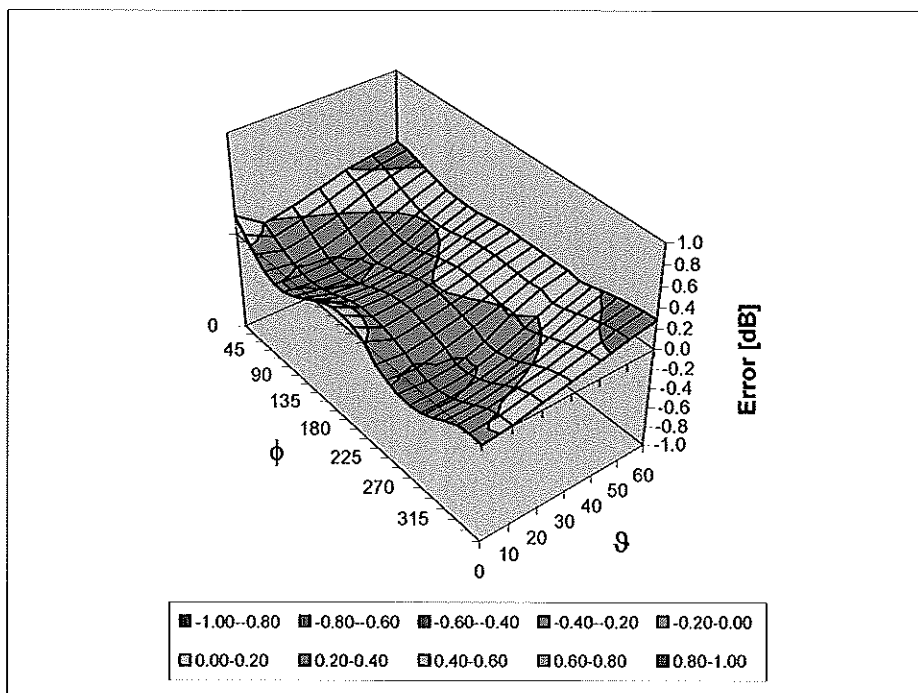

Uncertainty of Spherical Isotropy Assessment:  $\pm 2.6\%$  (k=2)

## Other Probe Parameters

Sensor Arrangement	Triangular
Connector Angle (°)	Not applicable
Mechanical Surface Detection Mode	enabled
Optical Surface Detection Mode	disabled
Probe Overall Length	337 mm
Probe Body Diameter	10 mm
Tip Length	9 mm
Tip Diameter	2.5 mm
Probe Tip to Sensor X Calibration Point	1 mm
Probe Tip to Sensor Y Calibration Point	1 mm
Probe Tip to Sensor Z Calibration Point	1 mm
Recommended Measurement Distance from Surface	2 mm



Accredited by the Swiss Accreditation Service (SAS)  
The Swiss Accreditation Service is one of the signatories to the EA  
Multilateral Agreement for the recognition of calibration certificates

Accreditation No.: **SCS 108**

Client **PC Test**

Certificate No: **D2450V2-719\_Aug09**

## CALIBRATION CERTIFICATE

Object **D2450V2 - SN: 719**

Calibration procedure(s) **QA CAL-05.v7  
Calibration procedure for dipole validation kits**

Calibration date: **August 27, 2009**

Condition of the calibrated item **In Tolerance**

This calibration certificate documents the traceability to national standards, which realize the physical units of measurements (SI).  
The measurements and the uncertainties with confidence probability are given on the following pages and are part of the certificate.

✓ OK  
S  
8/31/09

All calibrations have been conducted in the closed laboratory facility: environment temperature (22 ± 3)°C and humidity < 70%.

Calibration Equipment used (M&TE critical for calibration)

Primary Standards	ID #	Cal Date (Calibrated by, Certificate No.)	Scheduled Calibration
Power meter EPM-442A	GB37480704	08-Oct-08 (No. 217-00898)	Oct-09
Power sensor HP 8481A	US37292783	08-Oct-08 (No. 217-00898)	Oct-09
Reference 20 dB Attenuator	SN: 5086 (20g)	31-Mar-09 (No. 217-01025)	Mar-10
Type-N mismatch combination	SN: 5047.2 / 06327	31-Mar-09 (No. 217-01029)	Mar-10
Reference Probe ES3DV3	SN: 3205	26-Jun-09 (No. ES3-3205_Jun09)	Jun-10
DAE4	SN: 601	07-Mar-09 (No. DAE4-601_Mar09)	Mar-10
Secondary Standards	ID #	Check Date (in house)	Scheduled Check
Power sensor HP 8481A	MY41092317	18-Oct-02 (in house check Oct-07)	In house check: Oct-09
RF generator R&S SMT-06	100005	4-Aug-99 (in house check Oct-07)	In house check: Oct-09
Network Analyzer HP 8753E	US37390585 S4206	18-Oct-01 (in house check Oct-08)	In house check: Oct-09

	Name	Function	Signature
Calibrated by:	Jeton Kastrali	Laboratory Technician	
Approved by:	Katja Pokovic	Technical Manager	

Issued: August 27, 2009

This calibration certificate shall not be reproduced except in full without written approval of the laboratory.



Accredited by the Swiss Accreditation Service (SAS)  
The Swiss Accreditation Service is one of the signatories to the EA  
Multilateral Agreement for the recognition of calibration certificates

Accreditation No.: **SCS 108**

### Glossary:

TSL	tissue simulating liquid
ConvF	sensitivity in TSL / NORM x,y,z
N/A	not applicable or not measured

### Calibration is Performed According to the Following Standards:

- IEEE Std 1528-2003, "IEEE Recommended Practice for Determining the Peak Spatial-Averaged Specific Absorption Rate (SAR) in the Human Head from Wireless Communications Devices: Measurement Techniques", December 2003
- IEC 62209-1, "Procedure to measure the Specific Absorption Rate (SAR) for hand-held devices used in close proximity to the ear (frequency range of 300 MHz to 3 GHz)", February 2005
- Federal Communications Commission Office of Engineering & Technology (FCC OET), "Evaluating Compliance with FCC Guidelines for Human Exposure to Radiofrequency Electromagnetic Fields; Additional Information for Evaluating Compliance of Mobile and Portable Devices with FCC Limits for Human Exposure to Radiofrequency Emissions", Supplement C (Edition 01-01) to Bulletin 65

### Additional Documentation:

- DASY4/5 System Handbook

### Methods Applied and Interpretation of Parameters:

- Measurement Conditions:** Further details are available from the Validation Report at the end of the certificate. All figures stated in the certificate are valid at the frequency indicated.
- Antenna Parameters with TSL:** The dipole is mounted with the spacer to position its feed point exactly below the center marking of the flat phantom section, with the arms oriented parallel to the body axis.
- Feed Point Impedance and Return Loss:** These parameters are measured with the dipole positioned under the liquid filled phantom. The impedance stated is transformed from the measurement at the SMA connector to the feed point. The Return Loss ensures low reflected power. No uncertainty required.
- Electrical Delay:** One-way delay between the SMA connector and the antenna feed point. No uncertainty required.
- SAR measured:** SAR measured at the stated antenna input power.
- SAR normalized:** SAR as measured, normalized to an input power of 1 W at the antenna connector.
- SAR for nominal TSL parameters:** The measured TSL parameters are used to calculate the nominal SAR result.

## Measurement Conditions

DASY system configuration, as far as not given on page 1.

<b>DASY Version</b>	DASY5	V5.0
<b>Extrapolation</b>	Advanced Extrapolation	
<b>Phantom</b>	Modular Flat Phantom V5.0	
<b>Distance Dipole Center - TSL</b>	10 mm	with Spacer
<b>Zoom Scan Resolution</b>	dx, dy, dz = 5 mm	
<b>Frequency</b>	2450 MHz ± 1 MHz	

## Head TSL parameters

The following parameters and calculations were applied.

	Temperature	Permittivity	Conductivity
<b>Nominal Head TSL parameters</b>	22.0 °C	39.2	1.80 mho/m
<b>Measured Head TSL parameters</b>	(22.0 ± 0.2) °C	40.1 ± 6 %	1.80 mho/m ± 6 %
<b>Head TSL temperature during test</b>	(22.3 ± 0.2) °C	----	----

## SAR result with Head TSL

<b>SAR averaged over 1 cm<sup>3</sup> (1 g) of Head TSL</b>	Condition	
SAR measured	250 mW input power	13.3 mW / g
SAR normalized	normalized to 1W	53.2 mW / g
SAR for nominal Head TSL parameters <sup>1</sup>	normalized to 1W	<b>53.5 mW / g ± 17.0 % (k=2)</b>

<b>SAR averaged over 10 cm<sup>3</sup> (10 g) of Head TSL</b>	condition	
SAR measured	250 mW input power	6.23 mW / g
SAR normalized	normalized to 1W	24.9 mW / g
SAR for nominal Head TSL parameters <sup>1</sup>	normalized to 1W	<b>25.0 mW / g ± 16.5 % (k=2)</b>

<sup>1</sup> Correction to nominal TSL parameters according to d), chapter "SAR Sensitivities"

## Body TSL parameters

The following parameters and calculations were applied.

	Temperature	Permittivity	Conductivity
Nominal Body TSL parameters	22.0 °C	52.7	1.95 mho/m
Measured Body TSL parameters	(22.0 ± 0.2) °C	53.2 ± 6 %	2.01 mho/m ± 6 %
Body TSL temperature during test	(22.5 ± 0.2) °C	----	----

## SAR result with Body TSL

SAR averaged over 1 cm <sup>3</sup> (1 g) of Body TSL	Condition	
SAR measured	250 mW input power	13.0 mW / g
SAR normalized	normalized to 1W	52.0 mW / g
SAR for nominal Body TSL parameters <sup>2</sup>	normalized to 1W	<b>51.4 mW / g ± 17.0 % (k=2)</b>

SAR averaged over 10 cm <sup>3</sup> (10 g) of Body TSL	condition	
SAR measured	250 mW input power	6.00 mW / g
SAR normalized	normalized to 1W	24.0 mW / g
SAR for nominal Body TSL parameters <sup>2</sup>	normalized to 1W	<b>23.9 mW / g ± 16.5 % (k=2)</b>

<sup>2</sup> Correction to nominal TSL parameters according to d), chapter "SAR Sensitivities"

## Appendix

### Antenna Parameters with Head TSL

Impedance, transformed to feed point	53.4 $\Omega$ + 1.8 j $\Omega$
Return Loss	- 28.6 dB

### Antenna Parameters with Body TSL

Impedance, transformed to feed point	48.2 $\Omega$ + 3.9 j $\Omega$
Return Loss	- 27.2 dB

### General Antenna Parameters and Design

Electrical Delay (one direction)	1.150 ns
----------------------------------	----------

After long term use with 100W radiated power, only a slight warming of the dipole near the feedpoint can be measured.

The dipole is made of standard semirigid coaxial cable. The center conductor of the feeding line is directly connected to the second arm of the dipole. The antenna is therefore short-circuited for DC-signals.

No excessive force must be applied to the dipole arms, because they might bend or the soldered connections near the feedpoint may be damaged.

### Additional EUT Data

Manufactured by	SPEAG
Manufactured on	September 10, 2002

## DASY5 Validation Report for Head TSL

Date/Time: 27.08.2009 11:14:47

Test Laboratory: SPEAG, Zurich, Switzerland

**DUT: Dipole 2450 MHz; Type: D2450V2; Serial: D2450V2 - SN719**

Communication System: CW; Frequency: 2450 MHz; Duty Cycle: 1:1

Medium: HSL U11 BB

Medium parameters used:  $f = 2450$  MHz;  $\sigma = 1.8$  mho/m;  $\epsilon_r = 40.1$ ;  $\rho = 1000$  kg/m<sup>3</sup>

Phantom section: Flat Section

Measurement Standard: DASY5 (IEEE/IEC)

DASY5 Configuration:

- Probe: ES3DV3 - SN3205; ConvF(4.53, 4.53, 4.53); Calibrated: 26.06.2009
- Sensor-Surface: 3mm (Mechanical Surface Detection)
- Electronics: DAE4 Sn601; Calibrated: 07.03.2009
- Phantom: Flat Phantom 5.0 (front); Type: QD000P50AA; Serial: 1001
- Measurement SW: DASY5, V5.0 Build 120; SEMCAD X Version 13.4 Build 45

**Pin = 250 mW; d = 10 mm/Zoom Scan (7x7x7)/Cube 0: Measurement grid: dx=5mm, dy=5mm, dz=5mm**

Reference Value = 101.4 V/m; Power Drift = 0.025 dB

Peak SAR (extrapolated) = 27 W/kg

**SAR(1 g) = 13.3 mW/g; SAR(10 g) = 6.23 mW/g**

Maximum value of SAR (measured) = 17.2 mW/g

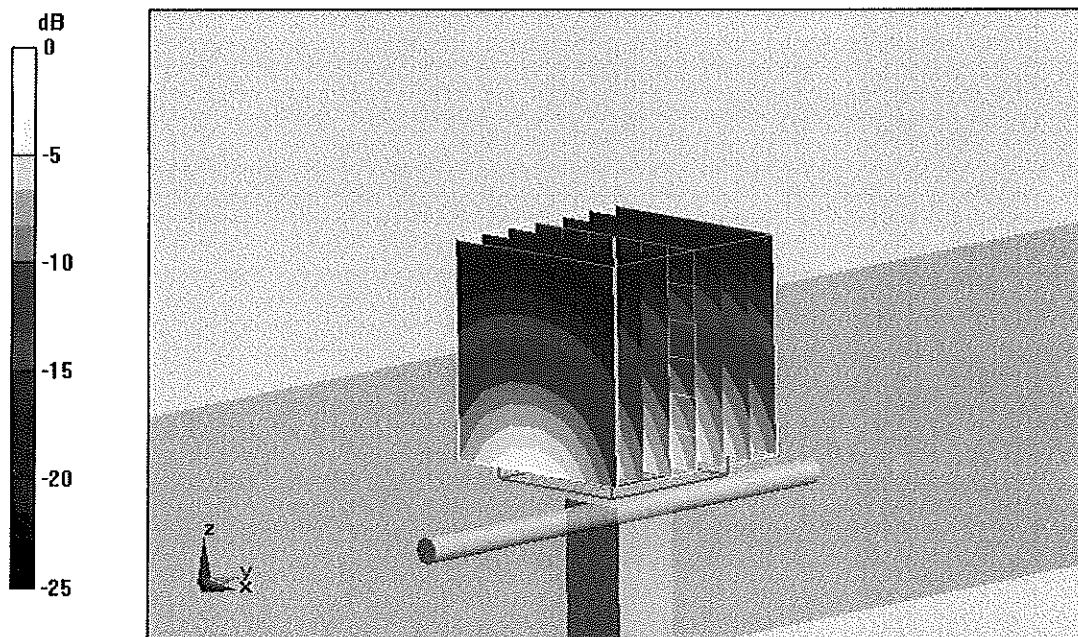

0 dB = 17.2mW/g

# Impedance Measurement Plot for Head TSL

27 Aug 2009 09:14:09

[CH1] S11 1 U FS 1: 53.385  $\Omega$  1.7910  $\Omega$  116.35 pF 2 450.000 000 MHz

\*  
Del  
Cor

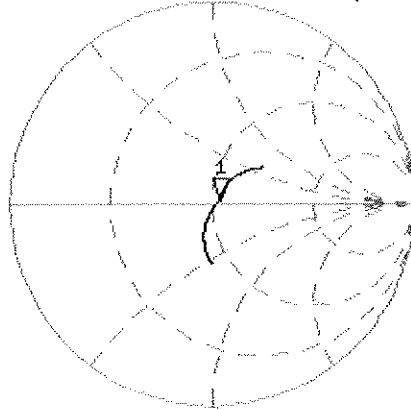

↑

CH2 S11 LOG 5 dB/REF -20 dB 1: -28.624 dB 2 450.000 000 MHz

Cor

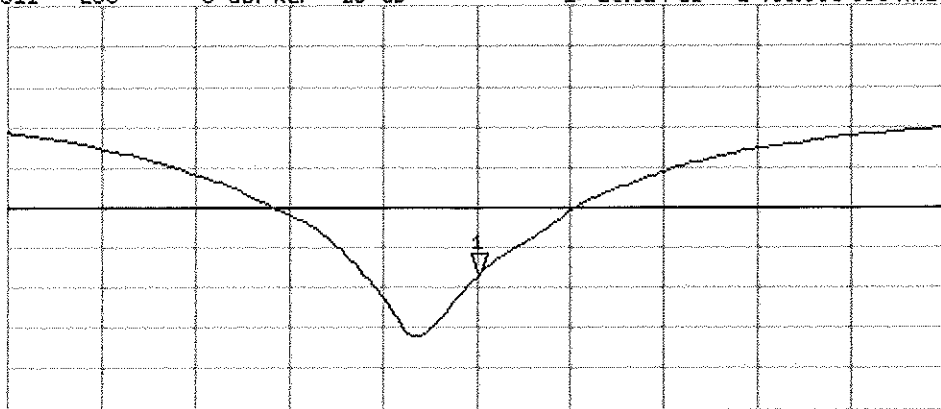

↑

START 2 250.000 000 MHz

STOP 2 650.000 000 MHz

## DASY5 Validation Report for Body TSL

Date/Time: 17.08.2009 15:35:28

Test Laboratory: SPEAG, Zurich, Switzerland

**DUT: Dipole 2450 MHz; Type: D2450V2; Serial: D2450V2 - SN:719**

Communication System: CW; Frequency: 2450 MHz; Duty Cycle: 1:1

Medium: MSL U10 BB

Medium parameters used:  $f = 2450$  MHz;  $\sigma = 2.01$  mho/m;  $\epsilon_r = 53.1$ ;  $\rho = 1000$  kg/m<sup>3</sup>

Phantom section: Flat Section

Measurement Standard: DASY5 (IEEE/IEC)

### DASY5 Configuration:

- Probe: ES3DV3 - SN3205; ConvF(4.31, 4.31, 4.31); Calibrated: 26.06.2009
- Sensor-Surface: 3mm (Mechanical Surface Detection)
- Electronics: DAE4 Sn601; Calibrated: 07.03.2009
- Phantom: Flat Phantom 5.0 (back); Type: QD000P50AA; Serial: 1002
- Measurement SW: DASY5, V5.0 Build 120; SEMCAD X Version 13.4 Build 45

**Pin = 250 mW; d = 10 mm/Zoom Scan (7x7x7)/Cube 0: Measurement grid: dx=5mm, dy=5mm, dz=5mm**

Reference Value = 94.8 V/m; Power Drift = -0.00649 dB

Peak SAR (extrapolated) = 27.2 W/kg

**SAR(1 g) = 13 mW/g; SAR(10 g) = 6 mW/g**

Maximum value of SAR (measured) = 17 mW/g

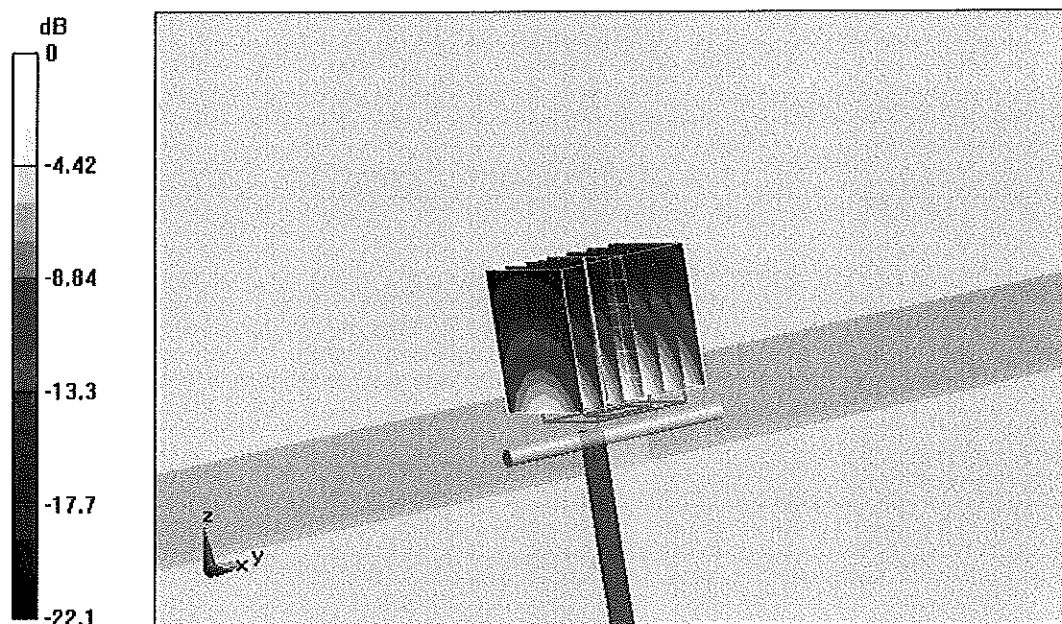

0 dB = 17mW/g

# Impedance Measurement Plot for Body TSL

17 Aug 2009 15:56:32

CH1 S11 1 U FS 1: 48.221  $\Omega$  3.9004  $\Omega$  253.37 pF 2 450.000 000 MHz

\*  
De1  
Cor  
Avg  
16  
↑

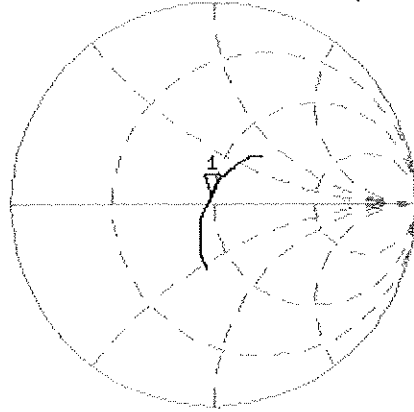

CH2 S11 LOG 5 dB/REF -20 dB 1: -27.205 dB 2 450.000 000 MHz

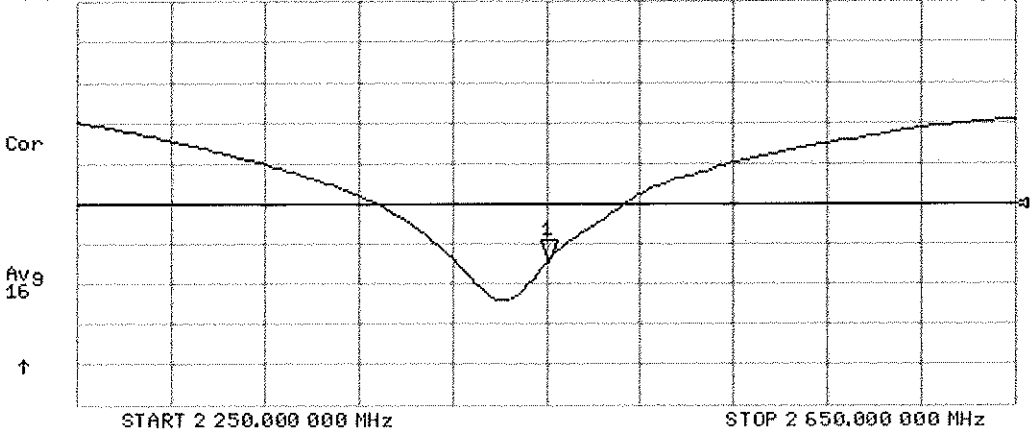



Accredited by the Swiss Accreditation Service (SAS)  
The Swiss Accreditation Service is one of the signatories to the EA  
Multilateral Agreement for the recognition of calibration certificates

Accreditation No.: **SCS 108**

Client **PC Test**

Certificate No: **D5GHzV2-1007\_Aug09**

**CALIBRATION CERTIFICATE**

Object **D5GHzV2 - SN: 1007**

Calibration procedure(s) **QA CAL-22.v1  
Calibration procedure for dipole validation kits between 3-6 GHz**

Calibration date: **August 19, 2009**

Condition of the calibrated item **In Tolerance**

This calibration certificate documents the traceability to national standards, which realize the physical units of measurements (SI).  
The measurements and the uncertainties with confidence probability are given on the following pages and are part of the certificate.

All calibrations have been conducted in the closed laboratory facility: environment temperature (22 ± 3)°C and humidity < 70%.

*OK*  
*8/31/09*

Calibration Equipment used (M&TE critical for calibration)

Primary Standards	ID #	Cal Date (Certificate No.)	Scheduled Calibration
Power meter EPM-442A	GB37480704	08-Oct-08 (No. 217-00898)	Oct-09
Power sensor HP 8481A	US37292783	08-Oct-08 (No. 217-00898)	Oct-09
Reference 20 dB Attenuator	SN: 5086 (20g)	31-Mar-09 (No. 217-01025)	Mar-10
Type-N mismatch combination	SN: 5047.2 / 06327	31-Mar-09 (No. 217-01029)	Mar-10
Reference Probe EX3DV4	SN: 3503	11-Mar-09 (No. EX3-3503_Mar09)	Mar-10
DAE4	SN: 601	07-Mar-09 (No. DAE4-601_Mar09)	Mar-10
Secondary Standards	ID #	Check Date (in house)	Scheduled Check
Power sensor HP 8481A	MY41092317	18-Oct-02 (in house check Oct-07)	In house check: Oct-09
RF generator R&S SMT-06	100005	4-Aug-99 (in house check Oct-07)	In house check: Oct-09
Network Analyzer HP 8753E	US37390585 S4206	18-Oct-01 (in house check Oct-08)	In house check: Oct-09

Calibrated by: **Jeton Kastrati** (Name), **Laboratory Technician** (Function), *[Signature]* (Signature)

Approved by: **Kalja Pokovic** (Name), **Technical Manager** (Function), *[Signature]* (Signature)

Issued: August 26, 2009

This calibration certificate shall not be reproduced except in full without written approval of the laboratory.



Accredited by the Swiss Accreditation Service (SAS)  
The Swiss Accreditation Service is one of the signatories to the EA  
Multilateral Agreement for the recognition of calibration certificates

Accreditation No.: **SCS 108**

### Glossary:

TSL	tissue simulating liquid
ConvF	sensitivity in TSL / NORM x,y,z
N/A	not applicable or not measured

### Calibration is Performed According to the Following Standards:

- IEC Std 62209 Part 2, "Evaluation of Human Exposure to Radio Frequency Fields from Handheld and Body-Mounted Wireless Communication Devices in the Frequency Range of 30 MHz to 6 GHz: Human models, Instrumentation, and Procedures"; Part 2: "Procedure to determine the Specific Absorption Rate (SAR) for including accessories and multiple transmitters", Draft Version 0.9, December 2004
- Federal Communications Commission Office of Engineering & Technology (FCC OET), "Evaluating Compliance with FCC Guidelines for Human Exposure to Radiofrequency Electromagnetic Fields; Additional Information for Evaluating Compliance of Mobile and Portable Devices with FCC Limits for Human Exposure to Radiofrequency Emissions", Supplement C (Edition 01-01) to Bulletin 65

### Additional Documentation:

- DASY4/5 System Handbook

### Methods Applied and Interpretation of Parameters:

- Measurement Conditions:** Further details are available from the Validation Report at the end of the certificate. All figures stated in the certificate are valid at the frequency indicated.
- Antenna Parameters with TSL:** The dipole is mounted with the spacer to position its feed point exactly below the center marking of the flat phantom section, with the arms oriented parallel to the body axis.
- Feed Point Impedance and Return Loss:** These parameters are measured with the dipole positioned under the liquid filled phantom. The impedance stated is transformed from the measurement at the SMA connector to the feed point. The Return Loss ensures low reflected power. No uncertainty required.
- Electrical Delay:** One-way delay between the SMA connector and the antenna feed point. No uncertainty required.
- SAR measured:** SAR measured at the stated antenna input power.
- SAR normalized:** SAR as measured, normalized to an input power of 1 W at the antenna connector.
- SAR for nominal TSL parameters:** The measured TSL parameters are used to calculate the nominal SAR result.

## Measurement Conditions

DASY system configuration, as far as not given on page 1.

<b>DASY Version</b>	DASY5	V5.0
<b>Extrapolation</b>	Advanced Extrapolation	
<b>Phantom</b>	Modular Flat Phantom V5.0	
<b>Distance Dipole Center - TSL</b>	10 mm	with Spacer
<b>Area Scan resolution</b>	dx, dy = 10 mm	
<b>Zoom Scan Resolution</b>	dx, dy = 4.0 mm, dz = 2.5 mm	
<b>Frequency</b>	5200 MHz ± 1 MHz 5500 MHz ± 1 MHz 5800 MHz ± 1 MHz	

## Body TSL parameters at 5200 MHz

The following parameters and calculations were applied.

	Temperature	Permittivity	Conductivity
<b>Nominal Body TSL parameters</b>	22.0 °C	49.0	5.30 mho/m
<b>Measured Body TSL parameters</b>	(22.0 ± 0.2) °C	48.2 ± 6 %	5.46 mho/m ± 6 %
<b>Body TSL temperature during test</b>	(22.5 ± 0.2) °C	----	----

## SAR result with Body TSL at 5200 MHz

<b>SAR averaged over 1 cm<sup>3</sup> (1 g) of Body TSL</b>	condition	
SAR measured	100 mW input power	7.92 mW / g
SAR normalized	normalized to 1W	79.2 mW / g
SAR for nominal Body TSL parameters <sup>1</sup>	normalized to 1W	<b>78.9 mW / g ± 19.9 % (k=2)</b>

<b>SAR averaged over 10 cm<sup>3</sup> (10 g) of Body TSL</b>	condition	
SAR measured	100 mW input power	2.21 mW / g
SAR normalized	normalized to 1W	22.1 mW / g
SAR for nominal Body TSL parameters <sup>1</sup>	normalized to 1W	<b>22.0 mW / g ± 19.5 % (k=2)</b>

### Body TSL parameters at 5500 MHz

The following parameters and calculations were applied.

	Temperature	Permittivity	Conductivity
Nominal Body TSL parameters	22.0 °C	48.6	5.65 mho/m
Measured Body TSL parameters	(22.0 ± 0.2) °C	47.4 ± 6 %	5.85 mho/m ± 6 %
Body TSL temperature during test	(22.5 ± 0.2) °C	----	----

### SAR result with Body TSL at 5500 MHz

SAR averaged over 1 cm <sup>3</sup> (1 g) of Body TSL	condition	
SAR measured	100 mW input power	8.45 mW / g
SAR normalized	normalized to 1W	84.5 mW / g
SAR for nominal Body TSL parameters <sup>1</sup>	normalized to 1W	<b>84.1 mW / g ± 19.9 % (k=2)</b>

SAR averaged over 10 cm <sup>3</sup> (10 g) of Body TSL	condition	
SAR measured	100 mW input power	2.34 mW / g
SAR normalized	normalized to 1W	23.4 mW / g
SAR for nominal Body TSL parameters <sup>1</sup>	normalized to 1W	<b>23.3 mW / g ± 19.5 % (k=2)</b>

### Body TSL parameters at 5800 MHz

The following parameters and calculations were applied.

	Temperature	Permittivity	Conductivity
Nominal Body TSL parameters	22.0 °C	48.2	6.00 mho/m
Measured Body TSL parameters	(22.0 ± 0.2) °C	46.9 ± 6 %	6.21 mho/m ± 6 %
Body TSL temperature during test	(22.5 ± 0.2) °C	----	----

### SAR result with Body TSL at 5800 MHz

SAR averaged over 1 cm <sup>3</sup> (1 g) of Body TSL	condition	
SAR measured	100 mW input power	7.26 mW / g
SAR normalized	normalized to 1W	72.6 mW / g
SAR for nominal Body TSL parameters <sup>1</sup>	normalized to 1W	<b>72.3 mW / g ± 19.9 % (k=2)</b>

SAR averaged over 10 cm <sup>3</sup> (10 g) of Body TSL	condition	
SAR measured	100 mW input power	2.00 mW / g
SAR normalized	normalized to 1W	20.0 mW / g
SAR for nominal Body TSL parameters <sup>1</sup>	normalized to 1W	<b>19.9 mW / g ± 19.5 % (k=2)</b>

<sup>1</sup> Correction to nominal TSL parameters according to c), chapter "SAR Sensitivities"

## Appendix

### Antenna Parameters with Body TSL at 5200 MHz

Impedance, transformed to feed point	53.7 $\Omega$ - 10.5 j $\Omega$
Return Loss	-19.5 dB

### Antenna Parameters with Body TSL at 5500 MHz

Impedance, transformed to feed point	49.7 $\Omega$ - 1.7 j $\Omega$
Return Loss	-35.2 dB

### Antenna Parameters with Body TSL at 5800 MHz

Impedance, transformed to feed point	58.4 $\Omega$ + 6.0 j $\Omega$
Return Loss	-20.5 dB

### General Antenna Parameters and Design

Electrical Delay (one direction)	1.200 ns
----------------------------------	----------

After long term use with 40 W radiated power, only a slight warming of the dipole near the feedpoint can be measured.

The dipole is made of standard semirigid coaxial cable. The center conductor of the feeding line is directly connected to the second arm of the dipole. The antenna is therefore short-circuited for DC-signals.

No excessive force must be applied to the dipole arms, because they might bend or the soldered connections near the feedpoint may be damaged.

### Additional EUT Data

Manufactured by	SPEAG
Manufactured on	August 28, 2003

## DASY5 Validation Report for Body TSL

Date/Time: 19.08.2009 11:42:20

Test Laboratory: SPEAG, Zurich, Switzerland

**DUT: Dipole 5GHz; Type: D5GHz; Serial: D5GHzV2 - SN:1007**

Communication System: CW-5GHz; Frequency: 5200 MHz; Frequency: 5500 MHz; Frequency: 5800 MHz;  
Duty Cycle: 1:1

Medium: MSL 3-6 GHz

Medium parameters used:  $f = 5200$  MHz;  $\sigma = 5.43$  mho/m;  $\epsilon_r = 48.2$ ;  $\rho = 1000$  kg/m<sup>3</sup> Medium parameters used:  $f = 5500$  MHz;  $\sigma = 5.82$  mho/m;  $\epsilon_r = 47.5$ ;  $\rho = 1000$  kg/m<sup>3</sup> Medium parameters used:  $f = 5800$  MHz;  $\sigma = 6.17$  mho/m;  $\epsilon_r = 46.9$ ;  $\rho = 1000$  kg/m<sup>3</sup>

Phantom section: Flat Section

Measurement Standard: DASY5 (IEEE/IEC)

DASY5 Configuration:

- Probe: EX3DV4 - SN3503; ConvF(4.88, 4.88, 4.88)ConvF(4.37, 4.37, 4.37)ConvF(4.57, 4.57, 4.57); Calibrated: 11.03.2009
- Sensor-Surface: 2mm (Mechanical Surface Detection)
- Electronics: DAE4 Sn601; Calibrated: 07.03.2009
- Phantom: Flat Phantom 5.0 (back); Type: QD000P50AA; Serial: 1002
- Measurement SW: DASY5, V5.0 Build 120; SEMCAD X Version 13.4 Build 45

**d=10mm, Pin=100mW, f=5200 MHz/Area Scan (61x61x1):** Measurement grid: dx=10mm, dy=10mm

Maximum value of SAR (interpolated) = 16.6 mW/g

**d=10mm, Pin=100mW, f=5200 MHz/Zoom Scan (8x8x10), dist=2mm (8x8x10)/Cube 0:**

Measurement grid: dx=4mm, dy=4mm, dz=2.5mm

Reference Value = 60 V/m; Power Drift = -0.00623 dB

Peak SAR (extrapolated) = 30.1 W/kg

**SAR(1 g) = 7.92 mW/g; SAR(10 g) = 2.21 mW/g**

Maximum value of SAR (measured) = 16.6 mW/g

**d=10mm, Pin=100mW, f=5500 MHz/Zoom Scan (8x8x10), dist=2mm (8x8x10)/Cube 0:**

Measurement grid: dx=4mm, dy=4mm, dz=2.5mm

Reference Value = 60.3 V/m; Power Drift = -0.042 dB

Peak SAR (extrapolated) = 34.2 W/kg

**SAR(1 g) = 8.45 mW/g; SAR(10 g) = 2.34 mW/g**

Maximum value of SAR (measured) = 18.2 mW/g

**d=10mm, Pin=100mW, f=5800 MHz/Zoom Scan (8x8x10), dist=2mm (8x8x10)/Cube 0:**

Measurement grid: dx=4mm, dy=4mm, dz=2.5mm

Reference Value = 54.5 V/m; Power Drift = -0.016 dB

Peak SAR (extrapolated) = 31.3 W/kg

**SAR(1 g) = 7.26 mW/g; SAR(10 g) = 2 mW/g**

Maximum value of SAR (measured) = 15.9 mW/g

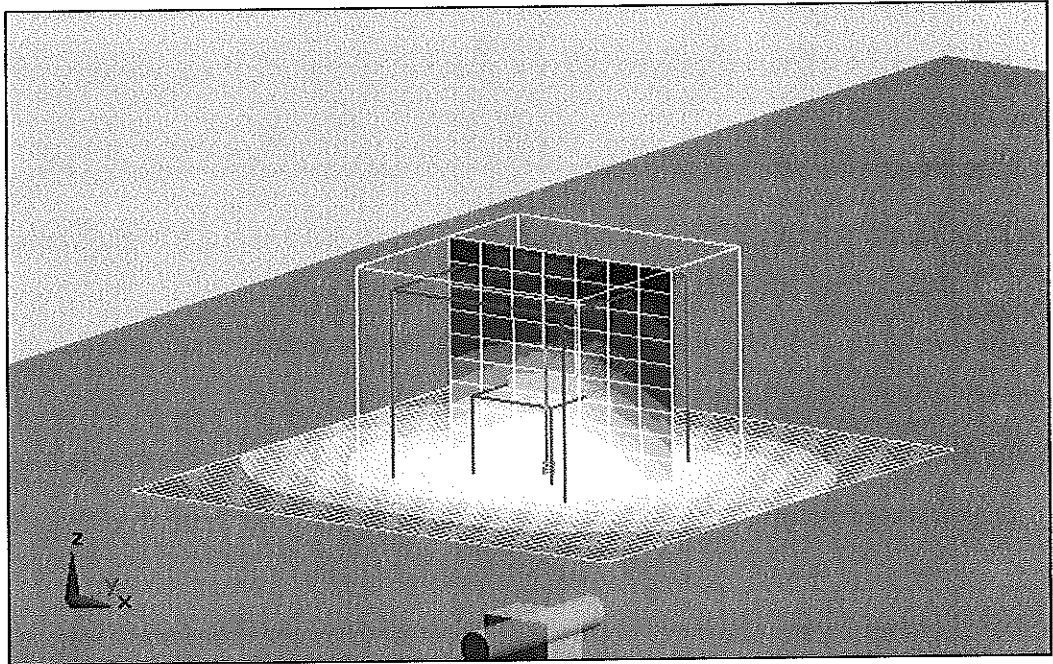

0 dB = 15.9mW/g

# Impedance Measurement Plot for Body TSL

19 Aug 2009 08:02:08

CH1 S11 1 U FS 1: 53.744  $\Omega$  -10.455  $\Omega$  2.9275 pF 5 200.000 000 MHz

\*  
De1  
Cor  
Avg  
16  
↑

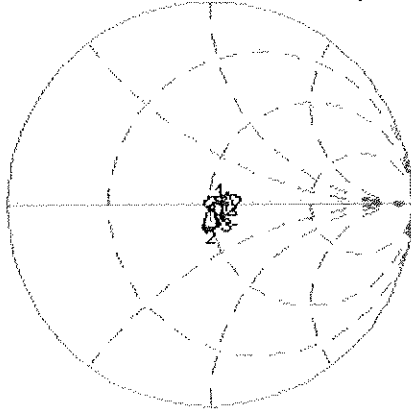

CH1 Markers

2: 49.705  $\Omega$   
-1.7051  $\Omega$   
5.50000 GHz  
3: 58.367  $\Omega$   
5.3902  $\Omega$   
5.80000 GHz

CH2 S11 LOG 5 dB/REF -20 dB 1: -19.452 dB 5 200.000 000 MHz

Cor  
Avg  
16  
↑

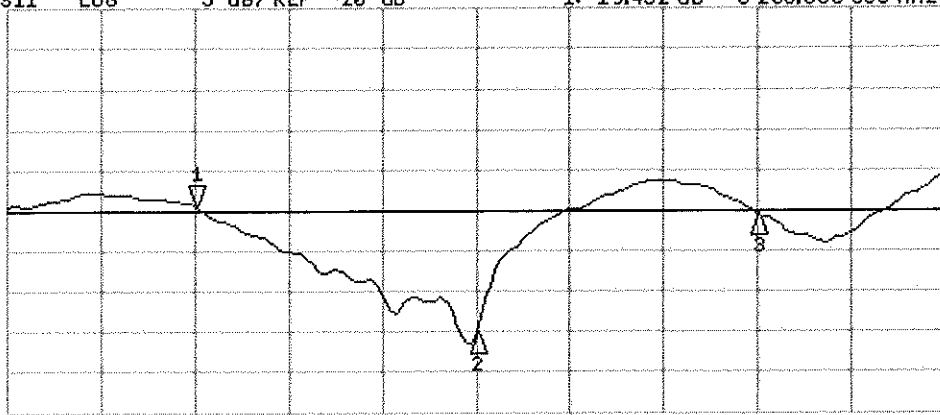

CH2 Markers

2: -35.210 dB  
5.50000 GHz  
3: -20.461 dB  
5.80000 GHz

START 5 000.000 000 MHz

STOP 5 000.000 000 MHz