

Technical Description

1. Use 'FILM' provided by 'SAMSUNG' for letter and contents
2. Background color is 'WHITE', letter color is 'BLACK'
(reverse for SAMSUNG LOGO)
3. Put 'release paper' on the back side after the adhesive.
4. No blur and spread for letter
5. Proceed with manufacturing process after the approval of R&D Group
6. The spec. of product must be based on approved limit samples.
7. Stock on as a ROLL
8. Follow drawing instruction above for CE or WEEE mark
9. Unify material and color as one color (blue) for glassine paper

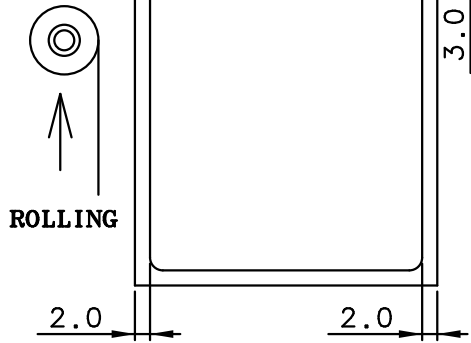

MAT.	White polypropylene 80 μ		FIN.				Semitransparency OPP Lamination + UVP Coating	
TITLE	GT-I9100G		LABEL (R) - MAIN - EU					
UNIT	mm	DESIGNED	CHECKED	APPROVED	PROJECTION			
TOLERANCE	+0.0 -0.1	AN DAE GEUN	kyeonghwan jo	junesop kim				
SCALE	N/S							
Manufacture	HANSUNG P&I	110315	110315	110315	SHEET NO	1/1		
		Doc. CODE	GH68-00000A					

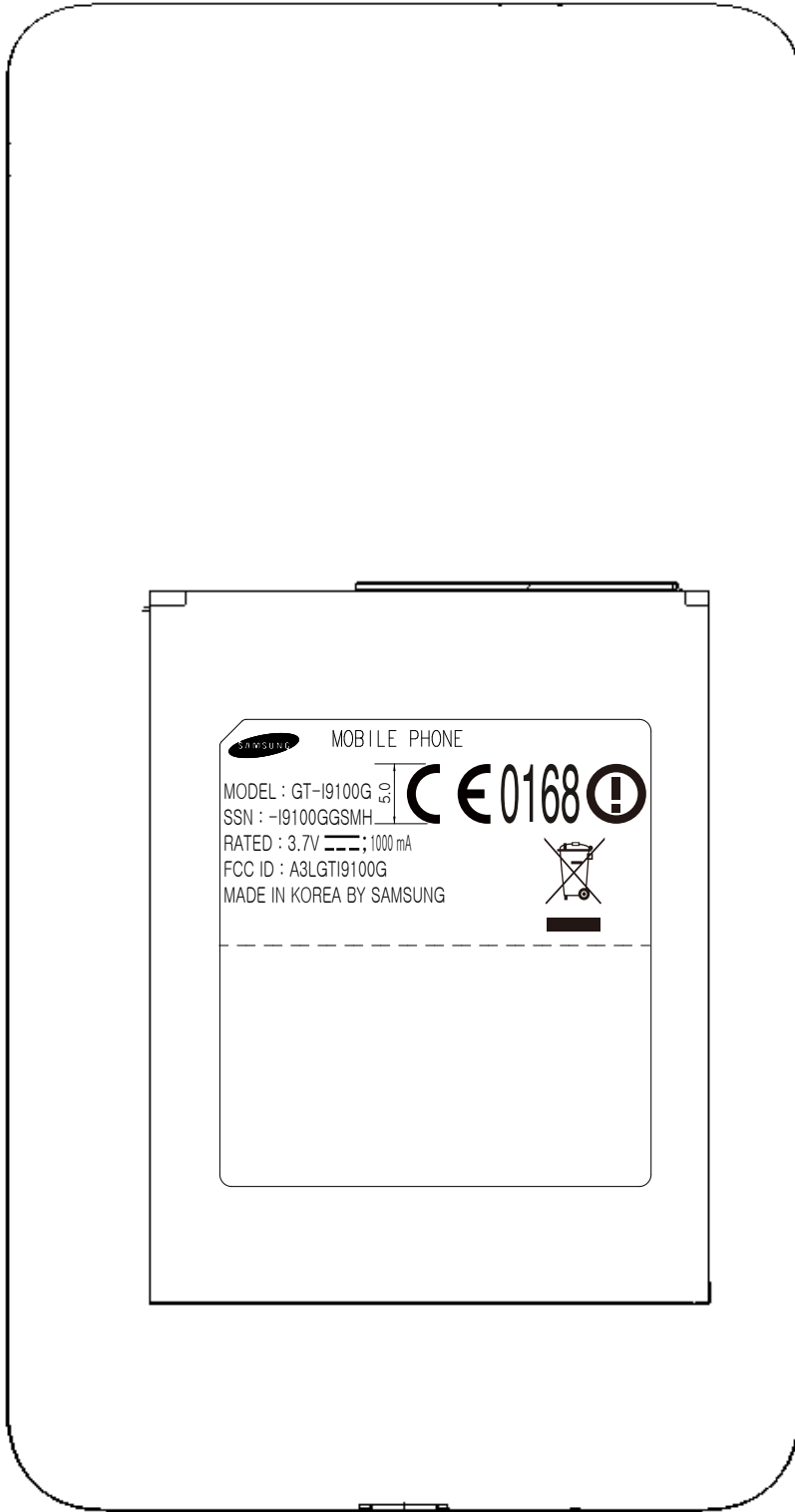

The label is placed inside the battery compartment