

# EMC TEST REPORT

<b>Project No.</b>	LBE20132947	<b>Issue No.</b>	0
<b>Applicant</b>	<b>Name of organization</b>	Samsung Electronics Co., Ltd.	
	<b>Address</b>	(Maetan-dong) 129, Samsung-ro, Yeongtong-gu, Suwon-si, Gyeonggi-do, 443-742, Republic of Korea	
	<b>Date of application</b>	May 14, 2013	
<b>EUT</b>	<b>Type of device</b>	<input checked="" type="checkbox"/> Class B personal computers and peripherals <input type="checkbox"/> All other devices	
	<b>Equipment authorization</b>	<input type="checkbox"/> Declaration of Conformity <input checked="" type="checkbox"/> Certification <input type="checkbox"/> Verification	
	<b>FCC ID</b>	A3LGTC3322I	
	<b>Kind of product</b>	Mobile Phone	
	<b>Model No.</b>	GT-C3322I	
	<b>Variant Model No.</b>	Refer to clause 4.6	
	<b>Manufacturer</b>	SAMSUNG ELECTRONICS CO., LTD. 94-1, Imsu-dong, Gumi-si, Gyengsangbuk-do, 730-722, Republic of Korea  SAMSUNG ELECTRONICS CO.,LTD. 201-305 Samsung India Electronics B-1, Sector-81 NOIDA UP, India	
<b>Applied Standards</b>	FCC Part 15, Subpart B, Class B / ANSI C63.4-2003		
<b>Test Period</b>	May 15, 2013 ~ May 22, 2013		
<b>Issue date</b>	May 23, 2013		

**Test result : Complied**

The equipment under test has found to be compliant with the applied standards.  
 (Refer to the attached test result for more detail.)

**Tested by** : Jong-Sup Jeong



**Reviewed by** : Tae-Young Jang



The test results in this report only apply to the tested sample. This report must not be reproduced, except in full, without written permission from CS & Environment center.



(Maetan-dong) 129, Samsung-ro, Yeongtong-gu, Suwon-si, Gyeonggi-do, 443-742, Republic of Korea  
 Tel: 82 31 279 1750, Fax: 82 31 279 1745

# Table of contents

## 1. Report Information

1.1 Revision history .....	3
----------------------------	---

## 2. Summary of test results

2.1 Emission .....	3
--------------------	---

## 3. General Information

3.1 Test facility .....	3
-------------------------	---

## 4. Test Configuration

4.1 Test Peripherals .....	4
4.2 EUT operating mode .....	4
4.3 Details of Sampling .....	4
4.4 Used cable description .....	5
4.5 Test arrangement .....	5
4.6 EUT Description .....	6
4.7 Clock Frequencies .....	6
4.8 Test configuration and condition .....	7
4.9 Measurement uncertainty .....	7

## 5. Result of individual tests

5.1 Conducted disturbance .....	8
5.2 Radiated disturbance .....	10

# 1. Report Information

## 1.1 Revision history

No.	Revised detailed information
Issue 0	- LBE20132947(SAMSUNG)

# 2. Summary of test results

## 1.1 Emission

The EUT has been tested according to the following specifications:

Applied	Test type	Applied standard	Result
<input checked="" type="checkbox"/>	Conducted Disturbance (Mains port)	FCC Part 15 Subpart B / ANSI C63.4-2003 (Class B)	Complied
<input checked="" type="checkbox"/>	Radiated Disturbance		Complied

# 3. General Information

## 3.1 Test facility

The CS & Environment center is located on Samsung Electronics Co., Ltd. at (Maetan-dong) 129, Samsung-ro, Yeongtong-gu, Suwon-si, Gyeonggi-do, Republic of Korea.

All testing are performed in Semi-anechoic chambers conforming to the site attenuation characteristics defined by ANSI C63.4, CISPR 22, 16-1 and 16-2. and Shielded rooms.

The CS & Environment center is operated as testing laboratory in accordance with the requirements of ISO/IEC 17025:2005.

## 4. Test Setup configuration

### 4.1 Test Peripherals

The cables used for these peripherals are either permanently attached by the peripheral manufacturer or coupled with an assigned cable as defined below.

The following is a listing of the EUT and peripherals utilized during the performance of EMC test:

Mark	Description	Model No.	Serial No.	Manufacturer / Trademark	FCC ID / DoC
A	Mobile Phone	GT-C3322I	-	SAMSUNG	A3LGTC3322I
B	Battery	AB463651BU	AA1CC04OS/4-B	SAMSUNG	-
C	Headset	EHS61ASFBE	-	SAMSUNG	-
D	Data Cable	ECC1DU0BBK	SJ1CA30BSE	SAMSUNG	-
E	microSD Card	16GB	-	SANDISK	-
F	Desk-Top Computer	HP Compaq dx2200 Microtower	CNG7060LW0	HP	DoC
G	LCD Monitor	CF19MS	CF19H1LS700048Y	SAMSUNG	DoC
H	Mouse	N3+Optical	K034729902	HP	DoC
I	Keyboard	SDM8500P	8M000131	SAMSUNG	DoC
J	Gigabit Switch 8	3CGSU08	AB/9XRQAC0024825	3COM	DoC
K	Power Supply	PW150	KA1203N03	AULT	DoC

### 4.2 EUT operating mode

To achieve compliance applied standard specification, the following mode(s) were made during compliance testing:

<b>Operating Mode 1</b>	USB Mode (Data Communication)
-------------------------	-------------------------------

### 4.3 Details of Sampling

Customer selected, single unit.

## 4.4 Used cable description

The EUT is configured, installed, arranged and operated in a manner consistent with typical applications. Interface cables/loads/devices are connected to at least one of each type of interface port of the EUT, and where practical, each cable shall be terminated in a device typical of actual usage. The type(s) of interconnecting cables to be used and the interface port (of the EUT) to which these were connected:

No.	Connected cable	Length [m]	Shielded [Y/N]	Note
1	Data Cable	0.8	Yes	From EUT to Desk-Top Computer,
2	Headset	1.6	No	For EUT
3	Power	1.8	No	For Desk-Top Computer
4	Power	1.8	No	For LCD Monitor
5	Power	1.8	No	From Gigabit Switch 8 to Power Supply
6	Power	1.8	No	For Power Supply
7	LAN	1.5	No	From Desk-Top Computer to Gigabit Switch 8
8	LAN	1.5	No	From Gigabit Switch 8 to Local Area Network
9	RGB	1.8	Yes	From Desk-Top Computer to LCD Monitor
10	PS/2	1.8	Yes	From Desk-Top Computer to Mouse
11	PS/2	1.8	Yes	From Desk-Top Computer to Keyboard

## 4.5 Test arrangement

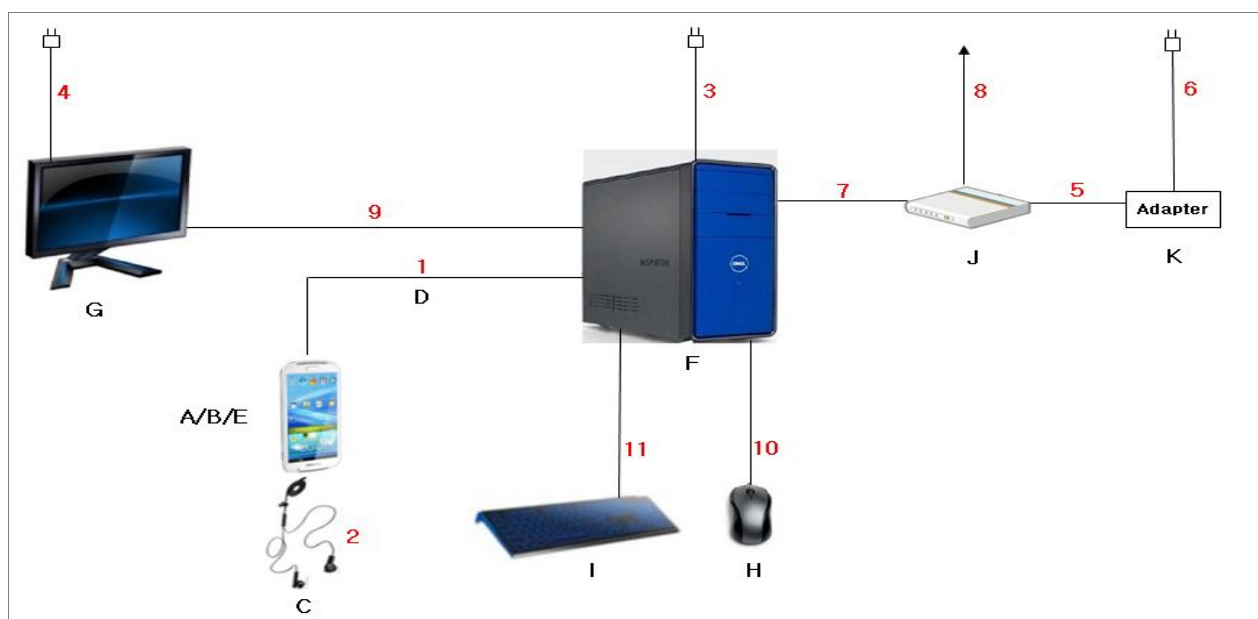

## 4.6 EUT Description

4.6.1 The following features describe EUT represented by this report:

Item	Specification	
Frequency Range	GSM850	TX : 824.2 ~ 848.8 MHz RX : 869.2 ~ 893.8 MHz
	GSM1900	TX : 1 850.2 ~ 1 909.8 MHz RX : 1 930.2 ~ 1 989.8 MHz
Operating Temperature (°C)	-20 ~ +60	
Operating Humidity (%)	0 ~ 95	

4.6.2 The variant models

- None

## 4.7 Clock Frequencies

Kind of Clocks	Frequency [ MHz ]
CPU	416

## 4.8 Test configuration and condition

- The EUT exercise program which is the samsung standardized emission test program for windows was used during all EMC measurements were tested. This program was contained on the PC hard disk drive. Once loaded, the program sequentially exercises each system component in turn.
- The EUT was exercised during the testing by data read and write cycles repeated with internal storage devices. At the end of the test, the copied back data was compared with original.
- The EUT was connected to the PC by using USB data cable to charge.
- The system was configured for testing in a typical fashion that a customer would normally use, and was tested while in an automated non-attendant mode.

Power source for the EUT operating was supplied by CVCF made by the Pacific Power Source Corp.

- Test Voltage : AC 120 V, 60 Hz

## 4.9 Measurement uncertainty

Where relevant, the following measurement uncertainty levels have been estimated for tests performed on the apparatus: (According to CISPR 16-4 and UKAS Lab 34.)

### 4.9.1 Emission

Test type		Measurement uncertainty (C.L. 95 %, k = 2)
Conducted disturbance	AC Mains	±3.31 dB
Radiated Disturbance (30 MHz ~ 1 GHz)	Horizontal	±5.15 dB
	Vertical	±5.13 dB
Radiated Disturbance (1 GHz ~ 6 GHz)	Horizontal	±4.13 dB
	Vertical	±4.12 dB

## 5. Results of individual test

### 5.1 Conducted disturbance

The EUT was connected to the Desk-Top Computer which was powered from one LISN for the measurements. The support equipment power cables were connected to a second LISN.

Both conducted lines are measured in Quasi-Peak and Average mode, including the worst-case data points for each tested configuration. The EUT measured in accordance with the methods described in standards.

#### Limits for conducted disturbance at the mains ports of Class B ITE

Frequency range Limits [ MHz ]	Resolution Bandwidth [ kHz ]	Limits [ dB(μV) ]	
		Quasi-peak	Average
0,15 to 0,50	9	66 to 56	56 to 46
0,50 to 5	9	56	46
5 to 30	9	60	50

NOTE 1 The lower limit shall apply at the transition frequency.  
NOTE 2 The limit decreases linearly with the logarithm of the frequency in the range 0.15 MHz to 0.50 MHz.

#### 5.1.1 Test instrumentation

EMC No.	Test Instrument	Model name	Manufacturer	Serial No.	Calibration	
					Date	Interval (Month)
E3I-260	LISN	ENV216	R&S	101366	2012-09-11	12
E3I-259	LISN	ENV216	R&S	101369	2012-12-07	12
E3I-132	EMI Test Receiver	ESIB-26	R&S	100291	2012-11-27	12

#### 5.1.2 Temperature and humidity condition

Test date	2013-05-22	Test engineer	Jong-Sup Jeong
Climate condition	Ambient temperature	23.9 °C	Limit (15.0 to 35.0) °C
	Relative humidity	41.0 % R.H.	Limit (25.0 to 75.0) % R.H.
	Atmospheric pressure	100.6 kPa	Limit (86.0 to 106.0) kPa
Test place	Shield Room (SR8)		

### 5.1.3 Test results

#### Operating Mode 1: AC Mains

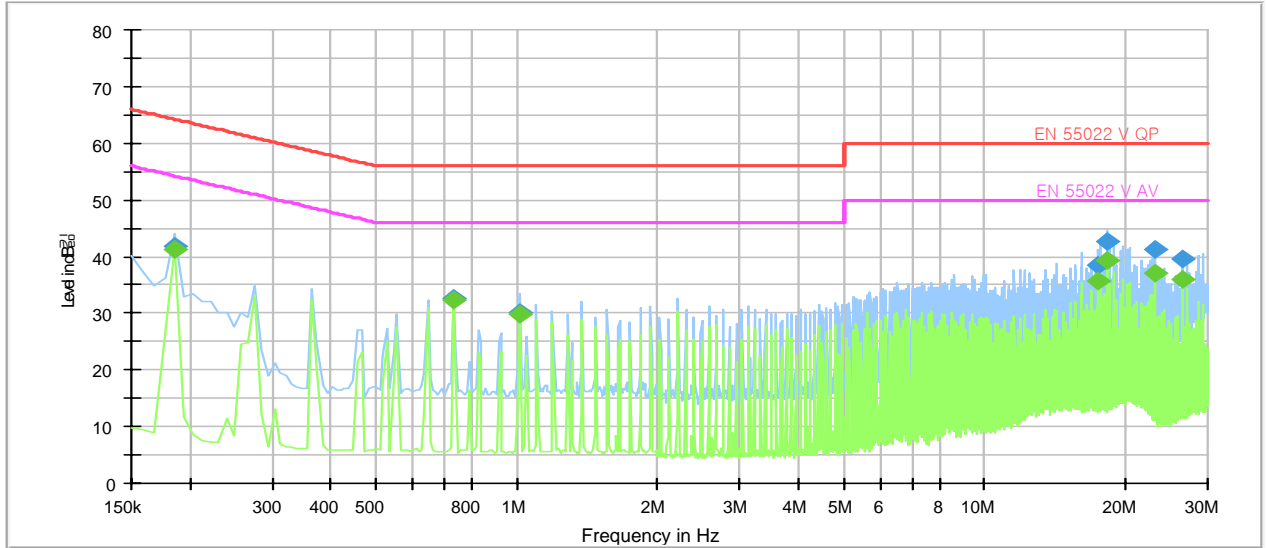

Note 1) Two graphs measured for both Live(L1) and Neutral(N) of the LISN are combined into one graph.

Quasi-peak final measurement results table:

Frequency (MHz)	Level (dBµV)	Corr. (dB)	Limit (dBµV)	Margin (dB)	Line
0.186	41.8	10.1	64.2	22.4	N
0.735	32.7	9.9	56.0	23.3	L1
1.014	30.1	9.8	56.0	25.9	L1
17.574	38.4	10.0	60.0	21.6	N
18.303	42.7	10.0	60.0	17.3	N
23.127	41.3	10.1	60.0	18.7	N
26.610	39.7	10.1	60.0	20.3	N

Average final measurement results table:

Frequency (MHz)	Level (dBµV)	Corr. (dB)	Limit (dBµV)	Margin (dB)	Line
0.186	41.3	10.1	54.2	12.9	N
0.735	32.3	9.9	46.0	13.7	L1
1.014	29.9	9.8	46.0	16.1	L1
17.574	35.7	10.0	50.0	14.3	N
18.366	39.3	10.0	50.0	10.7	N
23.127	37.2	10.1	50.0	12.8	N
26.610	36.0	10.1	50.0	14.0	N

Note 2) Level (QP and/or AV) = Meter Reading (QP and/or AV) + Corr. (LISN Insertion Loss + Cable Loss)

Margin (QP and/or AV) = Limit – Level (QP and/or AV)

QP = Quasi-Peak, AV = Average

## 5.2 Radiated disturbance

The following data lists the significant emission frequencies, measured levels, correction factors (for antenna and cables), orientation of table, polarization and height of antenna, the corrected reading, the limit, and the amount of margin.

Peak measurements were made over the changeable frequency range 30 MHz to 1 GHz at a measurement distance of 3 m for the following antenna and turntable arrangements:

Antenna Height [ cm ]	Antenna Polarisation	Resolution Bandwidth [ kHz ]	Video Bandwidth [ kHz ]	Turntable position [ degrees ]
100 ~ 400	Horizontal, Vertical	120	300	Continuous

Measurements within 6 dB of the limit were then maximized by adjusting turntable position. Final measurements were made using quasi-peak detector.

Peak/RMS-Average measurements were made over the changeable frequency range 1 GHz to 40 GHz or 5th harmonics of the highest frequency in accordance with internal maximum operating frequency at a measurement distance of 3 m for the following antenna and turntable arrangements:

Antenna Height [ cm ]	Antenna Polarisation	Resolution Bandwidth [ MHz ]	Video Bandwidth [ MHz ]	Turntable position [ degrees ]
100 ~ 400	Horizontal, Vertical	1	3	Continuous

Measurements within 6 dB of the limit were then maximized by adjusting turntable position. Final measurements were made using peak and rms-average detectors.

**Limits for radiated disturbance of Class B ITE at a measuring distance of 3 m and 10 m.**

Frequency range Limits [ MHz ]	Field Strength		
	3 m [ $\mu\text{V/m}$ ]	3 m [ dB( $\mu\text{V/m}$ ) ]	10 m [ dB( $\mu\text{V/m}$ ) ]
30 to 88	100	40.0	29.5
88 to 216	150	43.5	33.0
216 to 960	200	46.0	35.5
Above 960	500	54.0	43.5

Results checked manually; and points close to the limit line were re-measured.

## 5.2.1 Test instrumentation

EMC No.	Test Instrument	Model name	Manufacturer	Serial No.	Calibration	
					Date	Interval (Month)
E3I-190	BILOG Antenna	CBL6112B	Schaffner	2804	2011-06-22	24
E3I-170	Horn Antenna	HF906	R&S	100028	2012-08-13	24
E3I-212	Preamplifier	310N	Sonoma	282362	2012-11-14	12
E3I-142	EMI TEST RECEIVER	ESI-26	R&S	100019	2013-01-25	12
E3I-005	EMI TEST RECEIVER	ESIB-26	R&S	100355	2013-02-06	12

## 5.2.2 Temperature and humidity condition

<b>Test date</b>	2013-05-15	<b>Test engineer</b>	Jong-Sup Jeong
<b>Climate condition</b>	Ambient temperature	24.1 °C	Limit (15.0 to 35.0) °C
	Relative humidity	31.0 % R.H.	Limit (25.0 to 75.0) % R.H.
	Atmospheric pressure	100.9 kPa	Limit (86.0 to 106.0) kPa
<b>Test place</b>	Semi-Anechoic Chamber (SAC7)		

### 5.2.3 Test results

Operating Mode 1

- Frequency range: 30 ~ 1 000 MHz

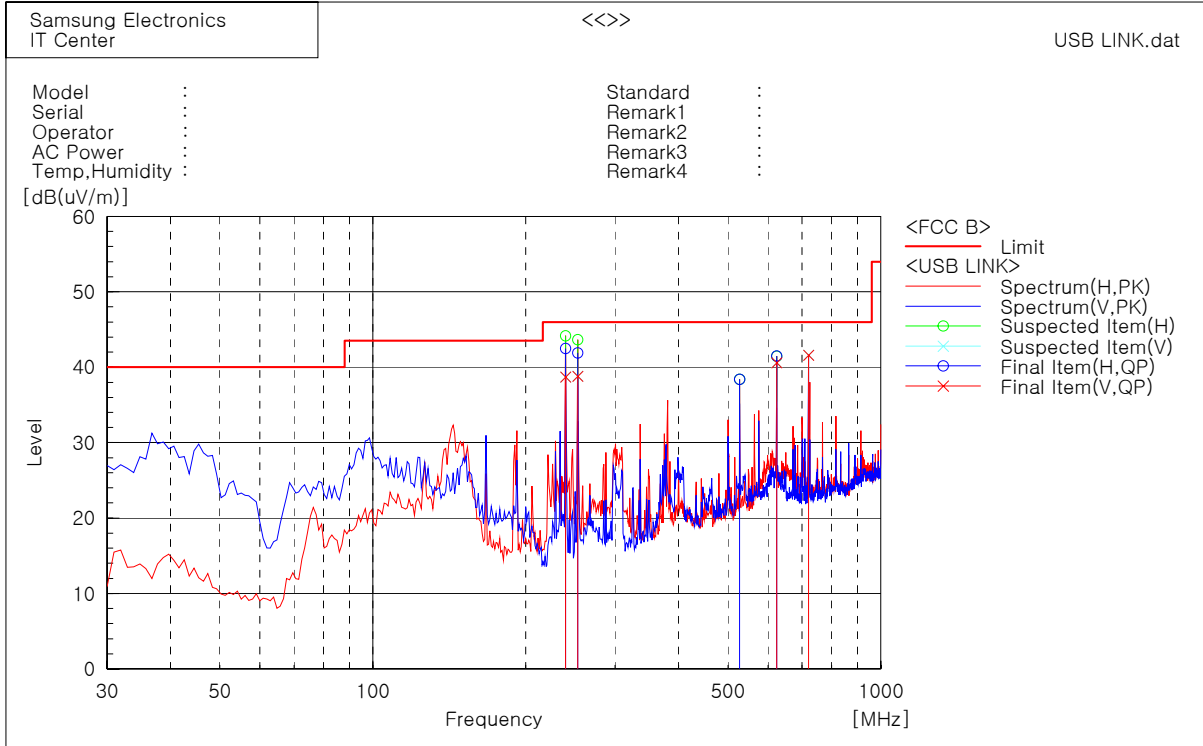

Final Result

No.	Frequency [MHz]	(P)	Reading QP [dB(uV)]	c.f [dB(1/m)]	Result QP [dB(uV/m)]	Limit QP [dB(uV/m)]	Margin QP [dB]	Height [cm]	Angle [deg]
1	239.607	H	59.6	-17.1	42.5	46.0	3.5	102.0	200.0
2	239.607	V	55.8	-17.1	38.7	46.0	7.3	198.0	354.0
3	253.130	V	53.9	-15.1	38.8	46.0	7.2	198.0	109.0
4	253.130	H	57.0	-15.1	41.9	46.0	4.1	108.0	191.0
5	527.647	H	48.1	-9.7	38.4	46.0	7.6	198.0	277.0
6	623.487	H	50.2	-8.7	41.5	46.0	4.5	102.0	293.0
7	623.487	V	49.3	-8.7	40.6	46.0	5.4	101.0	171.0
8	720.305	V	49.4	-7.8	41.6	46.0	4.4	101.0	129.0

Note) Receiving antenna polarization : Horizontal, Vertical  
 Test Distance : 3 m, Antenna Height : 1 to 4 meters  
 Level (QP) = Reading (QP) + c.f (Antenna Factor + Cable Loss - Amp. Gain)  
 Margin (QP) = Limit - Level (QP)  
 QP = Quasi-Peak

### 5.2.3 Test results

Operating Mode 1

- Frequency range: 1 000 ~ 2 000 MHz

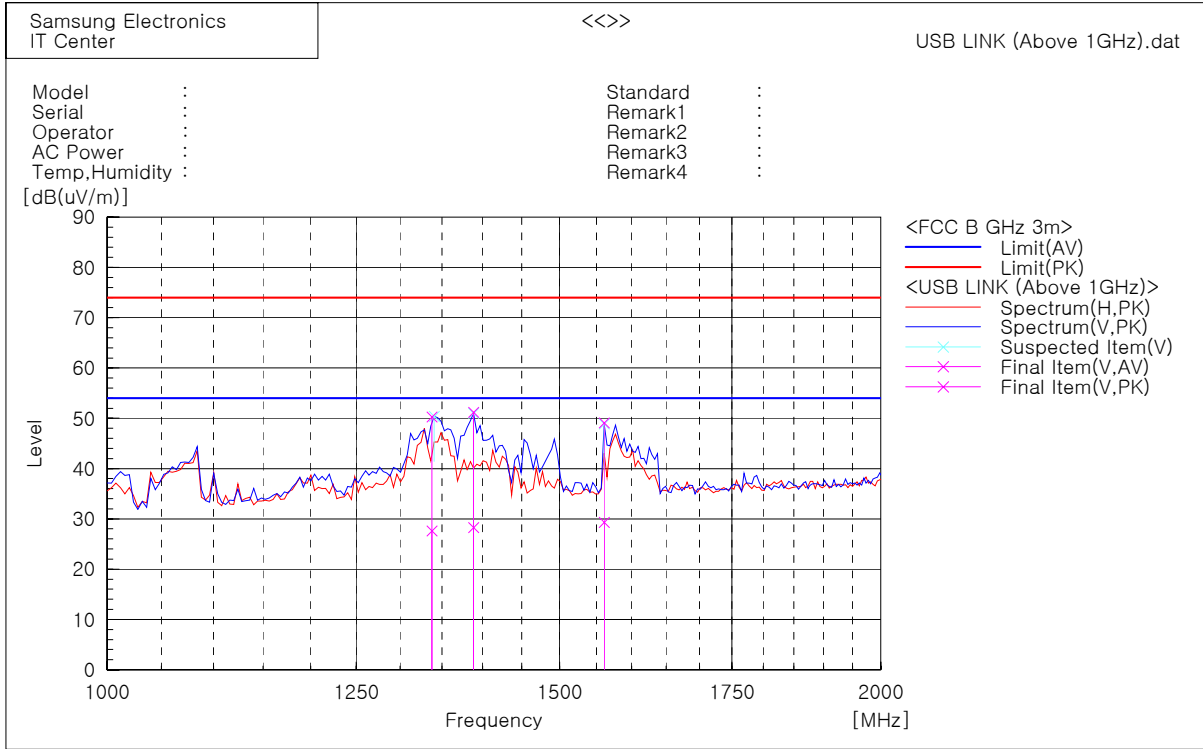

Final Result

--- Vertical Polarization (AV)---

No.	Frequency [MHz]	Reading [dB(uV)]	c.f [dB(1/m)]	Result [dB(uV/m)]	Limit [dB(uV/m)]	Margin [dB]	Height [cm]	Angle [deg]
1	1337.796	45.2	-17.6	27.6	54.0	26.4	103.0	201.0
2	1388.778	45.6	-17.3	28.3	54.0	25.7	103.0	201.0
3	1561.122	45.4	-16.1	29.3	54.0	24.7	103.0	193.0

--- Vertical Polarization (PK)---

No.	Frequency [MHz]	Reading [dB(uV)]	c.f [dB(1/m)]	Result [dB(uV/m)]	Limit [dB(uV/m)]	Margin [dB]	Height [cm]	Angle [deg]
1	1337.796	67.9	-17.6	50.3	74.0	23.7	103.0	201.0
2	1388.778	68.5	-17.3	51.2	74.0	22.8	103.0	201.0
3	1561.122	65.2	-16.1	49.1	74.0	24.9	103.0	193.0

Note ) Receiving antenna polarization : Horizontal, Vertical

Test Distance : 3 m, Antenna Height : 1 to 4 meters

Level (PK and/or AV) = Reading (PK and/or AV) + Corr. (Antenna Factor + Cable Loss - Amp. Gain)

Margin (PK and/or AV) = Limit - Level (PK and/or AV)

PK = Peak, AV = Average