

TEST REPORT

of

FCC Part 15 Subpart C §15.247
FCC ID: A3LGTB9062

Equipment Under Test : SAMSUNG Mobile Phone
Model Name : GT-B9062
Serial No. : N/A
Applicant : SAMSUNG ELECTRONICS CO., LTD.
Manufacturer : SAMSUNG ELECTRONICS CO., LTD.
Date of Test(s) : 2012.01.03 ~ 2012.01.10
Date of Issue : 2012.01.31

In the configuration tested, the EUT complied with the standards specified above.

Tested By:



Date

2012.01.31

Logan Lee

Approved By:



Date

2012.01.31

Feel Jeong

The results shown in this test report refer only to the sample(s) tested unless otherwise stated. This test report cannot be reproduced, except in full, without prior written permission of the Company.

Table of contents

1. General information -----	3
2. Transmitter radiated spurious emissions and conducted spurious emission-----	6
3. 6 dB Bandwidth measurement -----	25
4. Maximum peak output power -----	32
5. Power spectral density -----	35
6. Transmitter AC Power line conducted emission-----	42
7. Antenna requirement -----	47

The results shown in this test report refer only to the sample(s) tested unless otherwise stated. This test report cannot be reproduced, except in full, without prior written permission of the Company.

1. General information

1.1. Testing laboratory

SGS Korea Co., Ltd.(Gunpo Laboratory)

- 413-15, Gomae-Dong Giheung-Gu, Yongin-Si, Gyeonggi-Do, South Korea.
- Wireless Div. 2FL, 18-34, Sanbon-dong, Gunpo-si, Gyeonggi-do, Korea 435-040

www.kr.sgs.com/ee

Phone No. : +82 +31 428 5700

Fax No. : +82 +31 427 2371

1.2 Details of applicant

Applicant : SAMSUNG ELECTRONICS CO., LTD.
 Address : 416, Maetan3-dong, Yeongtong-gu, Suwon-si, Gyeonggi-do, Korea
 Contact Person : Lee, wontaek
 Phone No. : +82 +10 7260 8949

1.3 Description of EUT

Kind of Product	SAMSUNG Mobile Phone
Model Name	GT-B9062
Serial Number	N/A
Power Supply	DC 3.7 V (Li-Ion Battery)
Frequency Range	2 412 MHz ~ 2 462 MHz (11b/g/n-HT20)
Modulation Technique	DSSS, OFDM
Number of Channels	11
Antenna Type	Fixed type
Antenna Gain	-0.69 dB i

1.4. Declaration by the manufacturer

- WLAN & BT do not transmit simultaneously

The results shown in this test report refer only to the sample(s) tested unless otherwise stated. This test report cannot be reproduced, except in full, without prior written permission of the Company.

SGS Korea Co., Ltd. (Gunpo Laboratory) 18-34, Sanbon-dong, Gunpo-si, Gyeonggi-do, Korea, 435-040

Tel. +82 31 428 5700 / Fax. +82 31 427 2371

www.kr.sgs.com/ee

1.5. Test equipment list

Equipment	Manufacturer	Model	S/N	Cal Due.
Signal Generator	R & S	SMR40	100272	Jul. 15, 2012
Signal Generator	Agilent	8648D	3847M00534	Apr. 01, 2012
Spectrum Analyzer	R & S	FSV30	100955	Apr. 01, 2012
Power Sensor	R & S	NRP-Z81	101341	Sep. 29, 2012
Attenuator	Mini-Circuits	BW-N20W5+	0950-5	Mar. 30, 2012
Low Pass Filter	Mini-Circuits	NLP-1200+	V9500401023-3	Aug. 22, 2012
High Pass Filter	Wainwright	WHKX3.0/18G-6SS	4	Sep. 14, 2012
High Pass Filter	Wainwright	WHNX7.5/26.5G-6SS	11	Sep. 15, 2012
DC power Supply	Agilent	U8002A	MY50020026	Apr. 01, 2012
Preamplifier	H.P.	8447D	1726A01265	Sep. 27, 2012
Preamplifier	R & S	SCU-18	10070	Aug. 09, 2012
Preamplifier	SCHWARZBECK MESSELEKTRONIK	JS44-18004000-35-8P	1546891	Jul. 04, 2012
Test Receiver	R & S	ESU40	100075	Feb. 13, 2012
Bilog Antenna	SCHWARZBECK MESSELEKTRONIK	VULB9163	9163-437	Aug. 02, 2012
Horn Antenna	R & S	HF907	100208	Jun. 08, 2012
Horn Antenna	SCHWARZBECK MESSELEKTRONIK	BBHA9170	BBHA9170431	Mar. 17, 2012
Antenna Master	INNCO	MA4000-EP	N/A	N.C.R.
Turn Table	INNCO	DT-3000S	N/A	N.C.R.
Anechoic Chamber	SY Corporation	L x W x H (21.5 m x 13.0 m x 9.0 m)	N/A	N.C.R.
EMI Test Receiver	R & S	ESCI7	100778	Jul. 25, 2012
2-Line V-Network	R & S	ENV216	101180	May. 25, 2012

The results shown in this test report refer only to the sample(s) tested unless otherwise stated. This test report cannot be reproduced, except in full, without prior written permission of the Company.

1.6. Summary of test result

The EUT has been tested according to the following specifications:

Applied standard : FCC Part15 subpart C		
Standard section	Test Item	Result
15.205(a) 15.209(a) 15.247(d)	Transmitter radiated spurious emissions and Conducted spurious emission	Complied
15.247(a)(2)	6 dB Bandwidth	Complied
15.247(b)(3)	Maximum peak output power	Complied
15.247(e)	Power spectral density	Complied
15.207	Transmitter AC power line conducted emission	Complied

1.7. Description of test mode

802.11 b mode:

We found out the test mode with the highest power level after we analyze all the data rates. 1 Mbps data rate is chose (worst case) as a representative.

802.11 g mode:

We found out the test mode with the highest power level after we analyze all the data rates. 6 Mbps data rate is chose (worst case) as a representative.

802.11 n-HT20 mode:

We found out the test mode with the highest power level after we analyze all the data rates. MCS0 Mbps data rate is chose (worst case) as a representative.

1.8. Test report revision

Revision	Report number	Description
0	F690501/RF-RTL005247	Initial
1	F690501/RF-RTL005247-1	Test result for 6 dB bandwidth(802.11n, high channel) has been revised.

The results shown in this test report refer only to the sample(s) tested unless otherwise stated. This test report cannot be reproduced, except in full, without prior written permission of the Company.

2. Transmitter radiated spurious emissions and conducted spurious emission

2.1. Test setup

2.1.1. Transmitter radiated spurious emissions

The diagram below shows the test setup that is utilized to make the measurements for emission from 30 MHz to 1 GHz Emissions.

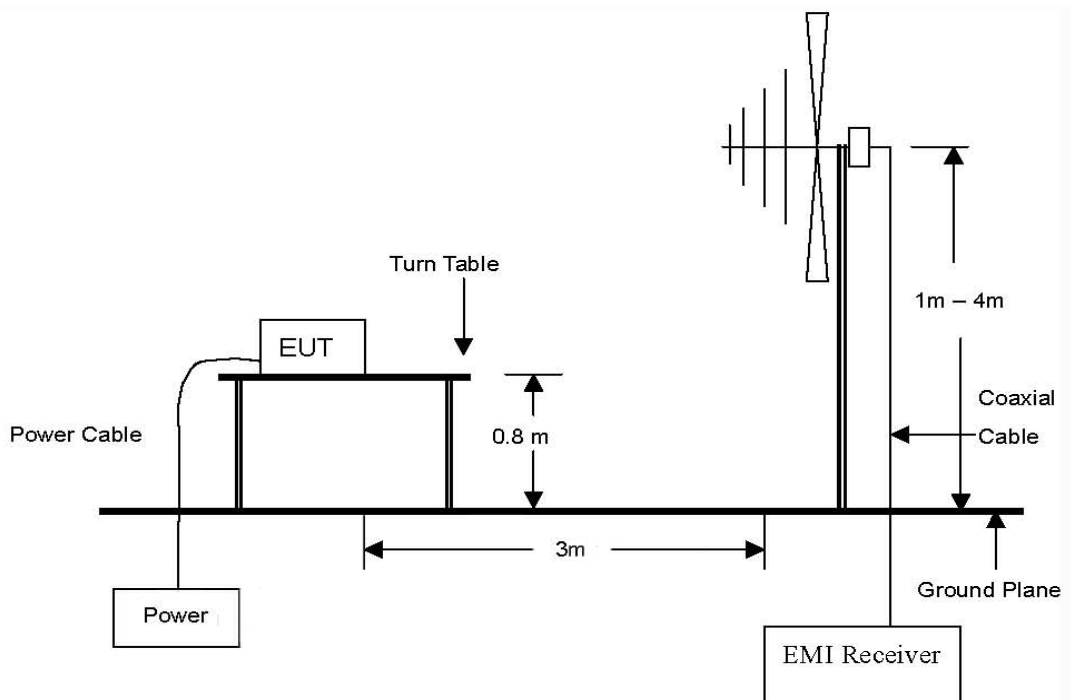

The diagram below shows the test setup that is utilized to make the measurements for emission from 1 GHz to 24.8 GHz Emissions.

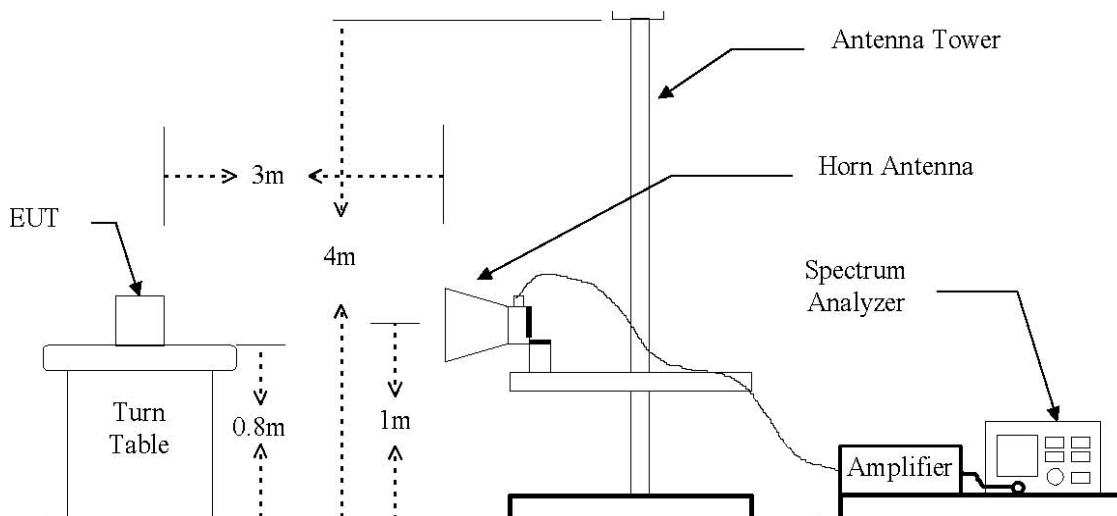

The results shown in this test report refer only to the sample(s) tested unless otherwise stated. This test report cannot be reproduced, except in full, without prior written permission of the Company.

2.1.2. Conducted spurious emissions



2.2. Limit

According to §15.247(d), in any 100 kHz bandwidth outside the frequency band in which the spread spectrum or digitally modulated intentional radiator is operating, the radio frequency power that is produced by the intentional radiator shall be at least 20 dB below that in the 100 kHz bandwidth within the band that contains the highest level of the desired power, based on either an RF conducted or a radiated measurement, provided the transmitter demonstrates compliance with the peak conducted power limits. If the transmitter complies with the conducted power limits based on the use of RMS averaging over a time interval, as permitted under paragraph(b)(3) of this section, the attenuation required under this paragraph shall be 30 dB instead of 20 dB. Attenuation below the general limits specified in section §15.209(a) is not required. In addition, radiated emission which in the restricted band, as define in section §15.205(a), must also comply the radiated emission limits specified in section §15.209(a) (see section §15.205(c))

According to § 15.109(a), for an intentional radiator devices, the general required of field strength of radiated emissions from unintentional radiators at a distance of 3 meters shall not exceed the following values :

Frequency (MHz)	Distance (Meters)	Radiated (dB µV/m)	Radiated (µV/m)
30 - 88	3	40.0	100
88 – 216	3	43.5	150
216 – 960	3	46.0	200
Above 960	3	54.0	500

The results shown in this test report refer only to the sample(s) tested unless otherwise stated. This test report cannot be reproduced, except in full, without prior written permission of the Company.

2.3. Test procedures

Radiated emissions from the EUT were measured according to the dictates of KDB558074

2.3.1. Test procedures for radiated spurious emissions

1. The EUT was placed on the top of a rotating table 0.8 meters above the ground at a 3 meter anechoic chamber test site. The table was rotated 360 degrees to determine the position of the highest radiation.
2. During performing radiated emission below 1 GHz, the EUT was set 3 meters away from the interference receiving antenna, which was mounted on the top of a variable-height antenna tower. During performing radiated emission above 1 GHz, the EUT was set 3 meter away from the interference-receiving antenna.
3. The antenna is a broadband antenna, and its height is varied from one meter to four meters above the ground to determine the maximum value of the field strength. Both horizontal and vertical polarizations of the antenna are set to make the measurement.
4. For each suspected emission, the EUT was arranged to its worst case and then the antenna was tuned to heights from 1 meter to 4 meters and the table was turned from 0 degrees to 360 degrees to find the maximum reading.
5. The test-receiver system was set to Peak Detect Function and Specified Bandwidth with Maximum Hold Mode.
6. If the emission level of the EUT in peak mode was 10 dB lower than the limit specified, then testing could be stopped and the peak values of the EUT would be reported. Otherwise the emissions that did not have 10 dB margin would be re-tested one by one using peak, quasi-peak or average method as specified and then reported in a data sheet.

■ Note

1. The resolution bandwidth and video bandwidth of test receiver/spectrum analyzer is 120 kHz for Peak detection (PK) or Quasi-peak detection (QP) at frequency below 1 GHz.
2. The resolution bandwidth and video bandwidth of test receiver/spectrum analyzer is 1 MHz for Peak detection and frequency above 1 GHz.
3. The resolution bandwidth of test receiver/spectrum analyzer is 1 MHz and the video bandwidth is 10 Hz for Average detection (AV) at frequency above 1 GHz.

2.3.2. Test procedures for conducted spurious emissions

1. The transmitter output was connected to the spectrum analyzer through an attenuator.
2. The bandwidth of the fundamental frequency was measured with the spectrum analyzer using RBW=100 kHz, VBW=100 kHz.

The results shown in this test report refer only to the sample(s) tested unless otherwise stated. This test report cannot be reproduced, except in full, without prior written permission of the Company.

2.4. Test result

Ambient temperature : (24 ± 2) °C
 Relative humidity : 47 % R.H.

2.4.1. Spurious radiated emission (Worst case configuration_11g mode)

The frequency spectrum from 30 MHz to 1 000 MHz was investigated. Emission levels are not reported much lower than the limits by over 30 dB. All reading values are peak values.

Radiated emissions			Ant	Correction factors		Total	Limit	
Frequency (MHz)	Reading (dB μ V)	Detect Mode	Pol.	AF (dB/m)	Amp gain+CL (dB)	Actual (dB uV/m)	Limit (dB uV/m)	Margin (dB)
37.37	35.59	Peak	H	12.91	-24.49	24.01	40.00	15.99
135.15	33.15	Peak	H	8.75	-23.39	18.51	43.50	24.99
349.71	29.38	Peak	H	14.05	-22.20	21.23	46.00	24.77
Above 400.00	Not detected	-	-	-	-	-	-	-

■ Remark:

1. All spurious emission at channels are almost the same below 1 GHz, so that the high channel was chosen at representative in final test.
2. Actual = Reading + AF + AMP + CL
3. To get a maximum emission level from the EUT, the EUT was moved throughout the X, Y and Z planes. The worst case is Y.

The results shown in this test report refer only to the sample(s) tested unless otherwise stated. This test report cannot be reproduced, except in full, without prior written permission of the Company.

2.4.2. Spurious radiated emission for above 1 GHz

The frequency spectrum above 1000 MHz was investigated. Emission levels are not reported much lower than the limits by over 30 dB.

DSSS : 802.11b

Low Channel (2 412 MHz)

Radiated Emissions			Ant	Correction Factors		Total	FCC Limit	
Frequency (MHz)	Reading (dB μ V)	Detect Mode	Pol.	AF (dB/m)	CL (dB)	Actual (dB μ V/m)	Limit (dB μ V/m)	Margin (dB)
*2 390.00	23.30	Peak	H	29.34	9.00	61.64	74.00	12.36
*2 390.00	11.87	Average	H	29.34	9.00	50.21	54.00	3.79

Radiated Emissions			Ant	Correction Factors		Total	FCC Limit	
Frequency (MHz)	Reading (dB μ V)	Detect Mode	Pol.	AF (dB/m)	AMP+CL (dB)	Actual (dB μ V/m)	Limit (dB μ V/m)	Margin (dB)
4 823.92	40.28	Peak	H	34.07	-29.88	44.47	74.00	29.53
Above 4 900.00	Not detected	-	-	-	-	-	-	-

Middle Channel (2 437 MHz)

Radiated Emissions			Ant	Correction Factors		Total	FCC Limit	
Frequency (MHz)	Reading (dB μ V)	Detect Mode	Pol.	AF (dB/m)	AMP+CL (dB)	Actual (dB μ V/m)	Limit (dB μ V/m)	Margin (dB)
4 874.08	40.46	Peak	H	34.14	-30.05	44.55	74.00	29.45
Above 4 900.00	Not detected	-	-	-	-	-	-	-

The results shown in this test report refer only to the sample(s) tested unless otherwise stated. This test report cannot be reproduced, except in full, without prior written permission of the Company.

High Channel (2 462 MHz)

Radiated Emissions			Ant	Correction Factors		Total	FCC Limit	
Frequency (MHz)	Reading (dB μ V)	Detect Mode	Pol.	AF (dB/m)	CL (dB)	Actual (dB μ V/m)	Limit (dB μ V/m)	Margin (dB)
*2 483.50	23.50	Peak	H	29.56	9.29	62.35	74.00	11.65
*2 483.50	11.84	Average	H	29.56	9.29	50.69	54.00	3.31

Radiated Emissions			Ant	Correction Factors		Total	FCC Limit	
Frequency (MHz)	Reading (dB μ V)	Detect Mode	Pol.	AF (dB/m)	AMP+CL (dB)	Actual (dB μ V/m)	Limit (dB μ V/m)	Margin (dB)
4 923.99	41.02	Peak	H	34.20	-30.20	45.02	74.00	28.98
Above 5 000.00	Not detected	-	-	-	-	-	-	-

The results shown in this test report refer only to the sample(s) tested unless otherwise stated. This test report cannot be reproduced, except in full, without prior written permission of the Company.

OFDM : 802.11g

Low Channel (2 412 MHz)

Radiated Emissions			Ant	Correction Factors		Total	FCC Limit	
Frequency (MHz)	Reading (dB μ V)	Detect Mode	Pol.	AF (dB/m)	CL (dB)	Actual (dB μ V/m)	Limit (dB μ V/m)	Margin (dB)
*2 390.00	23.12	Peak	H	29.34	9.00	61.46	74.00	12.54
*2 390.00	11.80	Average	H	29.34	9.00	50.14	54.00	3.86

Radiated Emissions			Ant	Correction Factors		Total	FCC Limit	
Frequency (MHz)	Reading (dB μ V)	Detect Mode	Pol.	AF (dB/m)	AMP+CL (dB)	Actual (dB μ V/m)	Limit (dB μ V/m)	Margin (dB)
4 821.44	40.27	Peak	H	34.07	-29.88	44.46	74.00	29.54
Above 4 900.00	Not detected	-	-	-	-	-	-	-

Middle Channel (2 437 MHz)

Radiated Emissions			Ant	Correction Factors		Total	FCC Limit	
Frequency (MHz)	Reading (dB μ V)	Detect Mode	Pol.	AF (dB/m)	AMP+CL (dB)	Actual (dB μ V/m)	Limit (dB μ V/m)	Margin (dB)
4 874.48	40.28	Peak	H	34.14	-30.05	44.37	74.00	29.63
Above 4 900.00	Not detected	-	-	-	-	-	-	-

The results shown in this test report refer only to the sample(s) tested unless otherwise stated. This test report cannot be reproduced, except in full, without prior written permission of the Company.

High Channel (2 462 MHz)

Radiated Emissions			Ant	Correction Factors		Total	FCC Limit	
Frequency (MHz)	Reading (dB μ V)	Detect Mode	Pol.	AF (dB/m)	CL (dB)	Actual (dB μ V/m)	Limit (dB μ V/m)	Margin (dB)
*2 483.50	24.07	Peak	H	29.56	9.29	62.92	74.00	11.08
*2 483.50	11.79	Average	H	29.56	9.29	50.64	54.00	3.36

Radiated Emissions			Ant	Correction Factors		Total	FCC Limit	
Frequency (MHz)	Reading (dB μ V)	Detect Mode	Pol.	AF (dB/m)	AMP+CL (dB)	Actual (dB μ V/m)	Limit (dB μ V/m)	Margin (dB)
4 924.00	40.03	Peak	H	34.20	-30.20	44.03	74.00	29.97
Above 5 000.00	Not detected	-	-	-	-	-	-	-

The results shown in this test report refer only to the sample(s) tested unless otherwise stated. This test report cannot be reproduced, except in full, without prior written permission of the Company.

OFDM : 802.11n – HT20

Low Channel (2 412 MHz)

Radiated Emissions			Ant	Correction Factors		Total	FCC Limit	
Frequency (MHz)	Reading (dB μ V)	Detect Mode	Pol.	AF (dB/m)	CL (dB)	Actual (dB μ V/m)	Limit (dB μ V/m)	Margin (dB)
*2 390.00	23.51	Peak	H	29.34	9.00	61.85	74.00	12.15
*2 390.00	11.77	Average	H	29.34	9.00	50.11	54.00	3.89

Radiated Emissions			Ant	Correction Factors		Total	FCC Limit	
Frequency (MHz)	Reading (dB μ V)	Detect Mode	Pol.	AF (dB/m)	AMP+CL (dB)	Actual (dB μ V/m)	Limit (dB μ V/m)	Margin (dB)
4 825.60	40.68	Peak	H	34.07	-29.89	44.86	74.00	29.14
Above 4 900.00	Not detected	-	-	-	-	-	-	-

Middle Channel (2 437 MHz)

Radiated Emissions			Ant	Correction Factors		Total	FCC Limit	
Frequency (MHz)	Reading (dB μ V)	Detect Mode	Pol.	AF (dB/m)	AMP+CL (dB)	Actual (dB μ V/m)	Limit (dB μ V/m)	Margin (dB)
4 874.63	41.12	Peak	H	34.14	-30.05	45.21	74.00	28.79
Above 4 900.00	Not detected	-	-	-	-	-	-	-

The results shown in this test report refer only to the sample(s) tested unless otherwise stated. This test report cannot be reproduced, except in full, without prior written permission of the Company.

High Channel (2 462 MHz)

Radiated Emissions			Ant	Correction Factors		Total	FCC Limit	
Frequency (MHz)	Reading (dB μ V)	Detect Mode	Pol.	AF (dB/m)	CL (dB)	Actual (dB μ V/m)	Limit (dB μ V/m)	Margin (dB)
*2 483.50	23.44	Peak	H	29.56	9.29	62.29	74.00	11.71
*2 483.50	11.54	Average	H	29.56	9.29	50.39	54.00	3.61

Radiated Emissions			Ant	Correction Factors		Total	FCC Limit	
Frequency (MHz)	Reading (dB μ V)	Detect Mode	Pol.	AF (dB/m)	AMP+CL (dB)	Actual (dB μ V/m)	Limit (dB μ V/m)	Margin (dB)
4 922.36	40.11	Peak	H	34.20	-30.20	44.11	74.00	29.89
Above 5 000.00	Not detected	-	-	-	-	-	-	-

■ Remarks

1. "*" means the restricted band.
2. Measuring frequencies from 1 GHz to the 10th harmonic of highest fundamental Frequency.
3. Radiated emissions measured in frequency above 1 000 MHz were made with an instrument using peak/average detector mode.
4. Average test would be performed if the peak result were greater than the average limit.
5. Actual = Reading + AF + AMP + CL
6. To get a maximum emission level from the EUT, the EUT was moved throughout the X, Y and Z planes. The worst case is Y.

The results shown in this test report refer only to the sample(s) tested unless otherwise stated. This test report cannot be reproduced, except in full, without prior written permission of the Company.

2.4.3. Spurious RF Conducted Emissions: Plot of Spurious RF Conducted Emission

DSSS : 802.11b

Low Channel

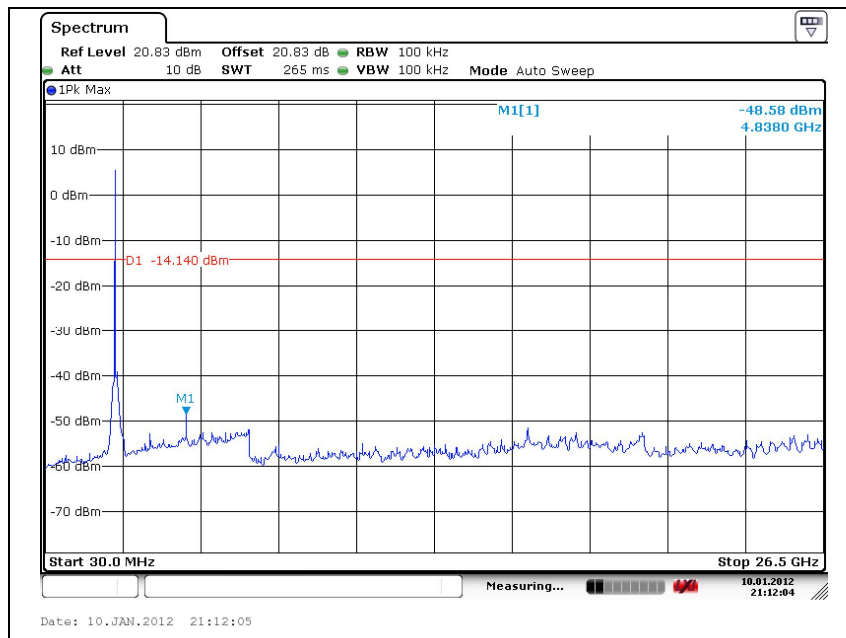
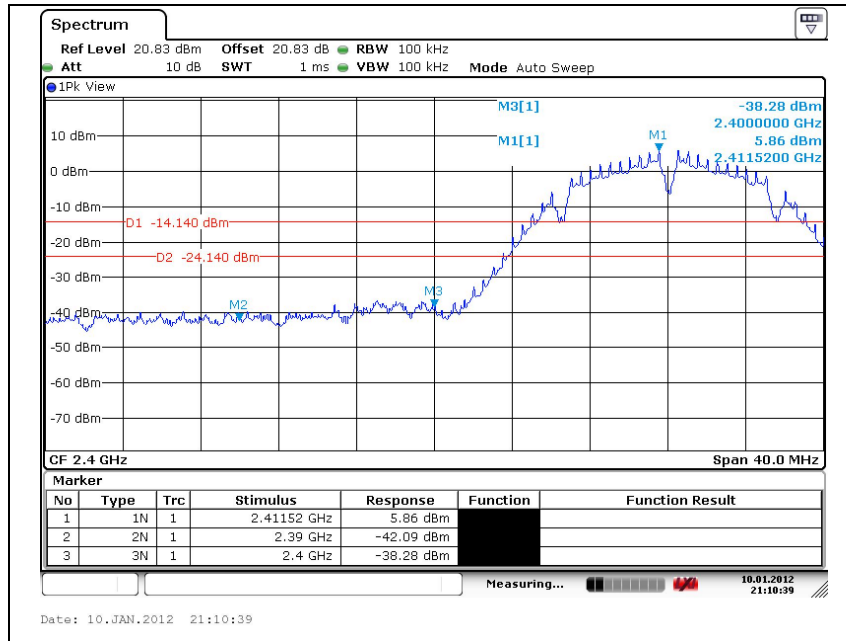

The results shown in this test report refer only to the sample(s) tested unless otherwise stated. This test report cannot be reproduced, except in full, without prior written permission of the Company.

Middle Channel

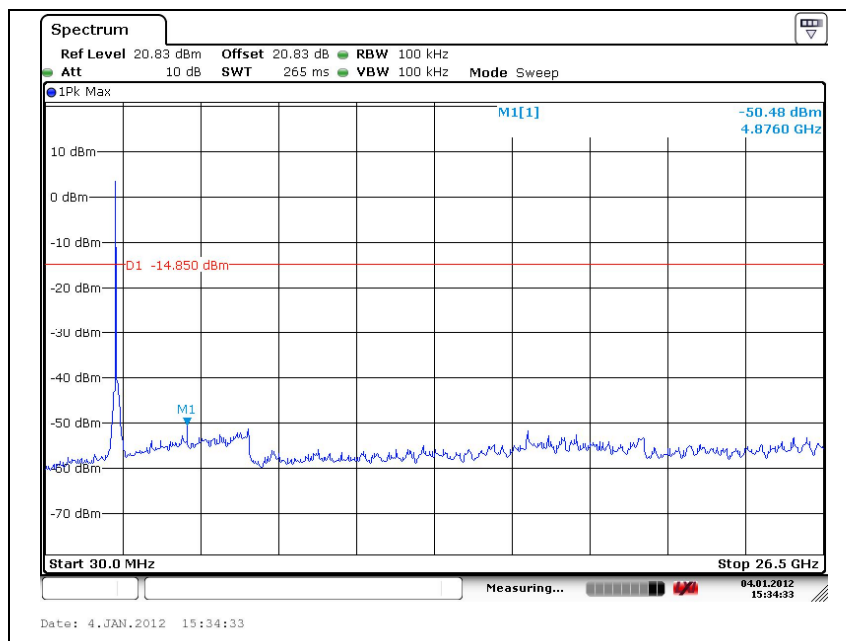
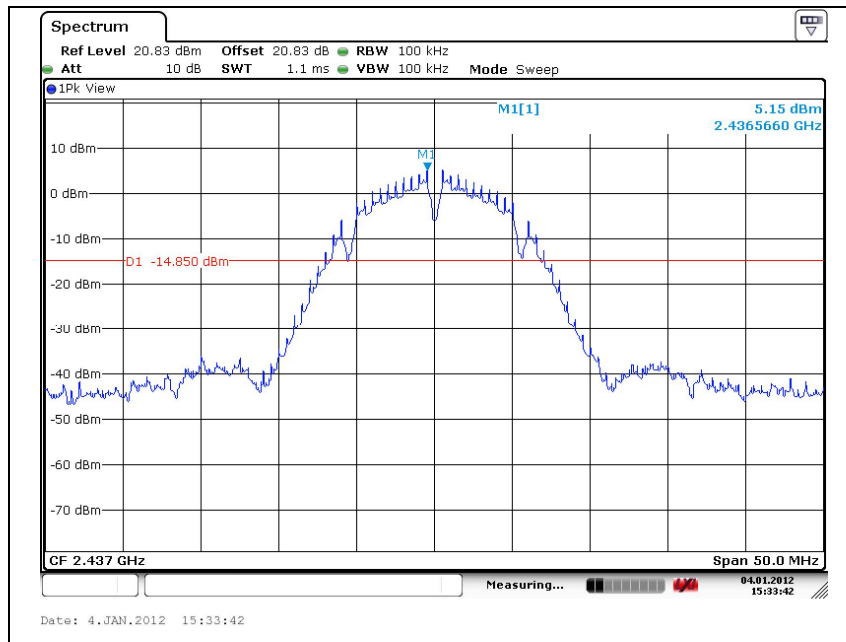

The results shown in this test report refer only to the sample(s) tested unless otherwise stated. This test report cannot be reproduced, except in full, without prior written permission of the Company.

High Channel

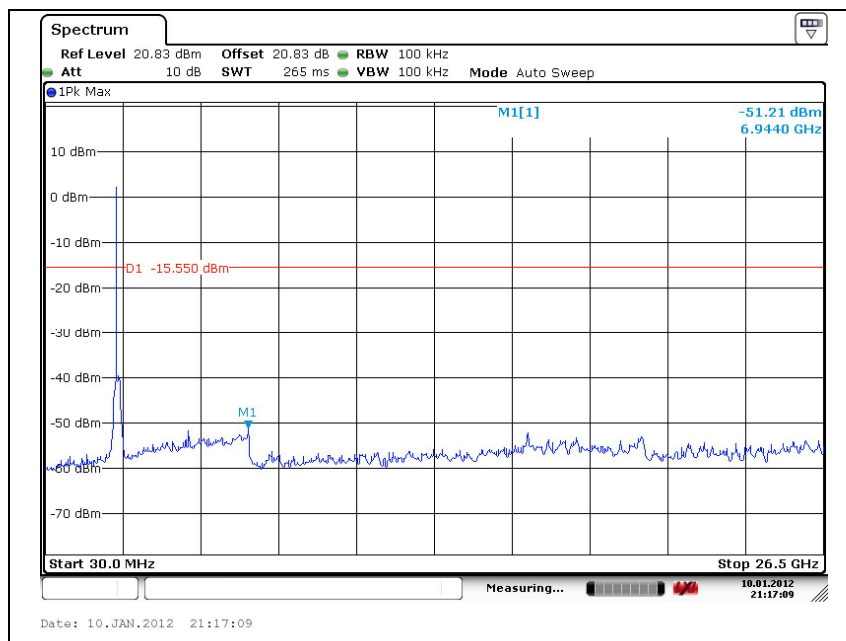
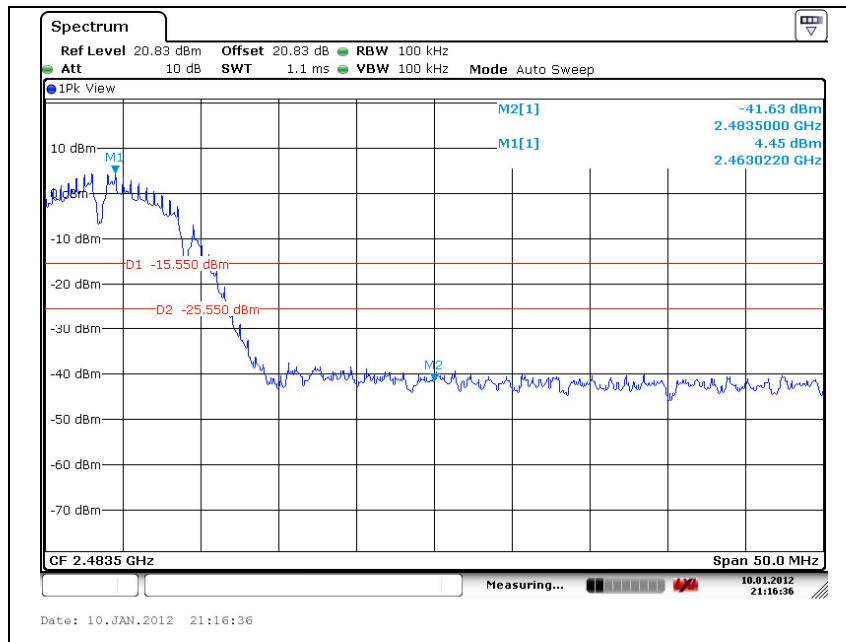

The results shown in this test report refer only to the sample(s) tested unless otherwise stated. This test report cannot be reproduced, except in full, without prior written permission of the Company.

OFDM : 802.11g

Low Channel

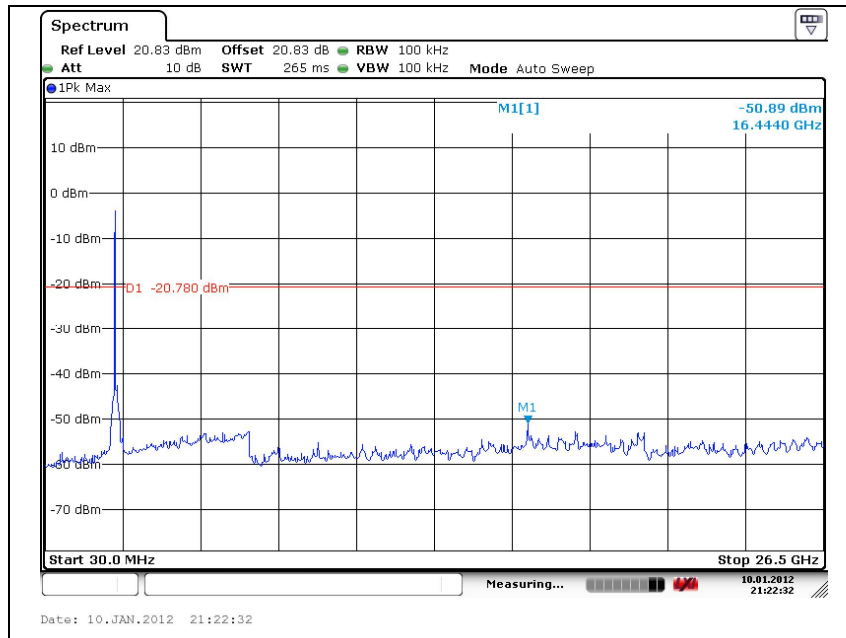
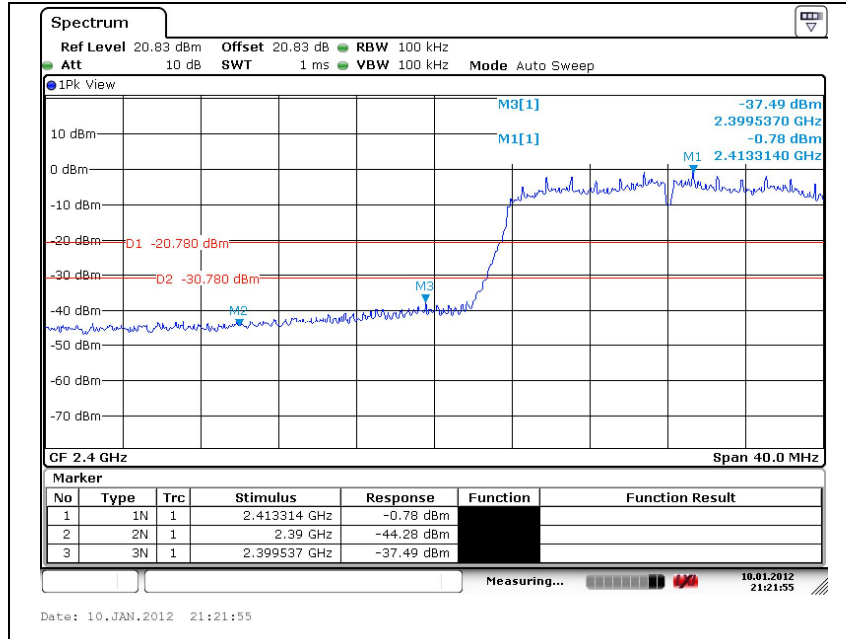

The results shown in this test report refer only to the sample(s) tested unless otherwise stated. This test report cannot be reproduced, except in full, without prior written permission of the Company.

Middle Channel

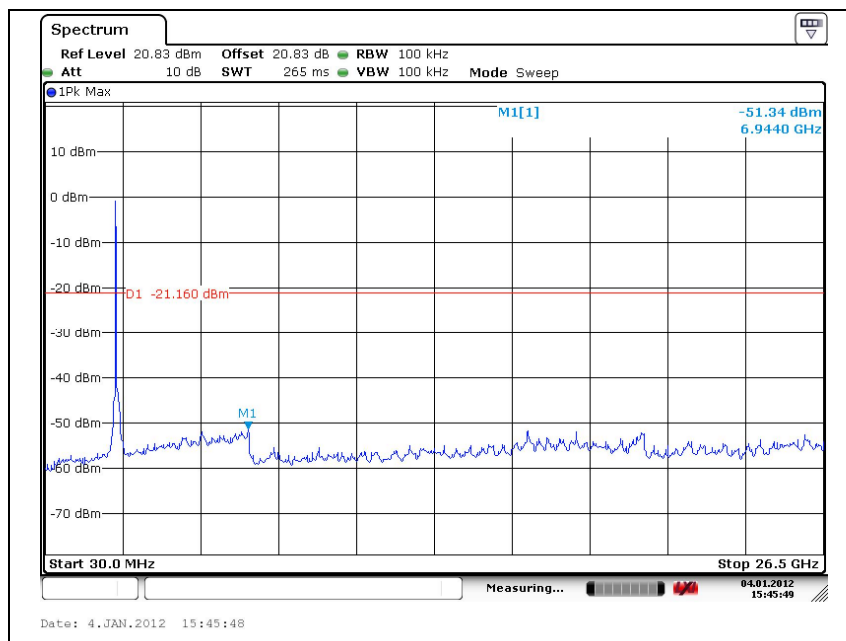
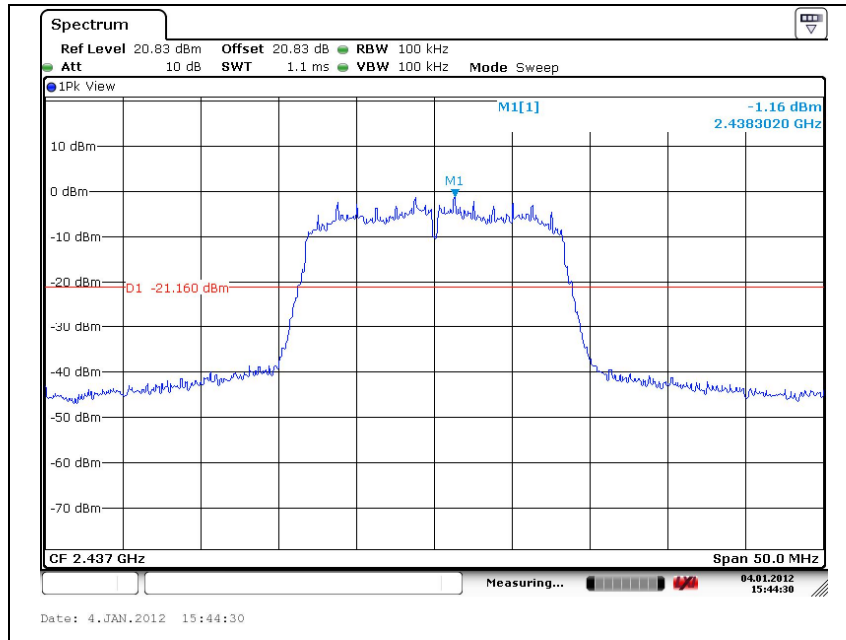

The results shown in this test report refer only to the sample(s) tested unless otherwise stated. This test report cannot be reproduced, except in full, without prior written permission of the Company.

High Channel

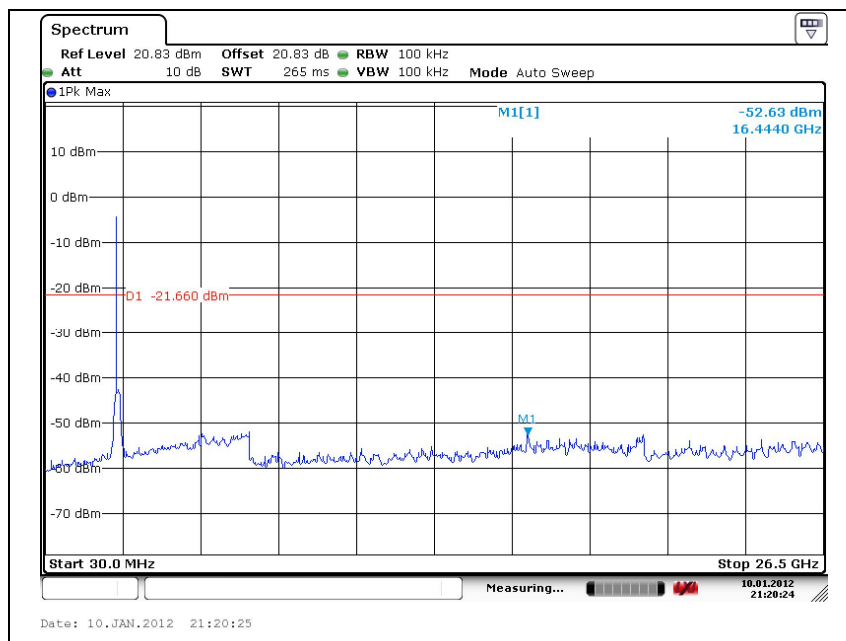
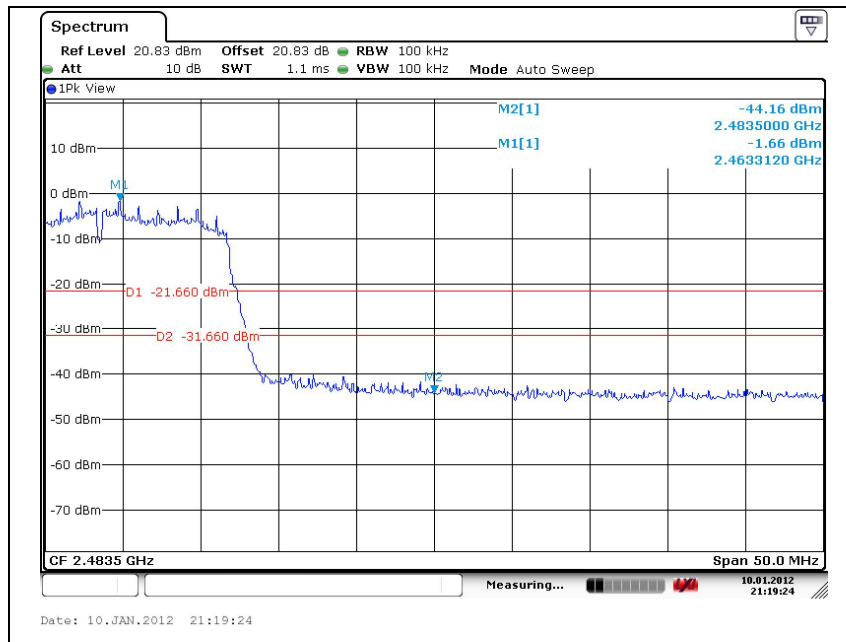

The results shown in this test report refer only to the sample(s) tested unless otherwise stated. This test report cannot be reproduced, except in full, without prior written permission of the Company.

OFDM : 802.11n-HT20

Low Channel

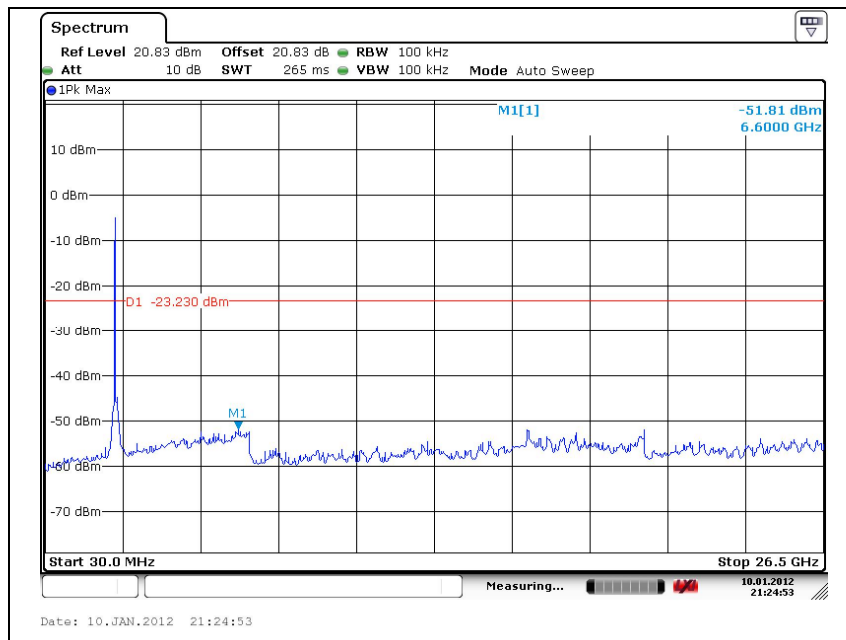
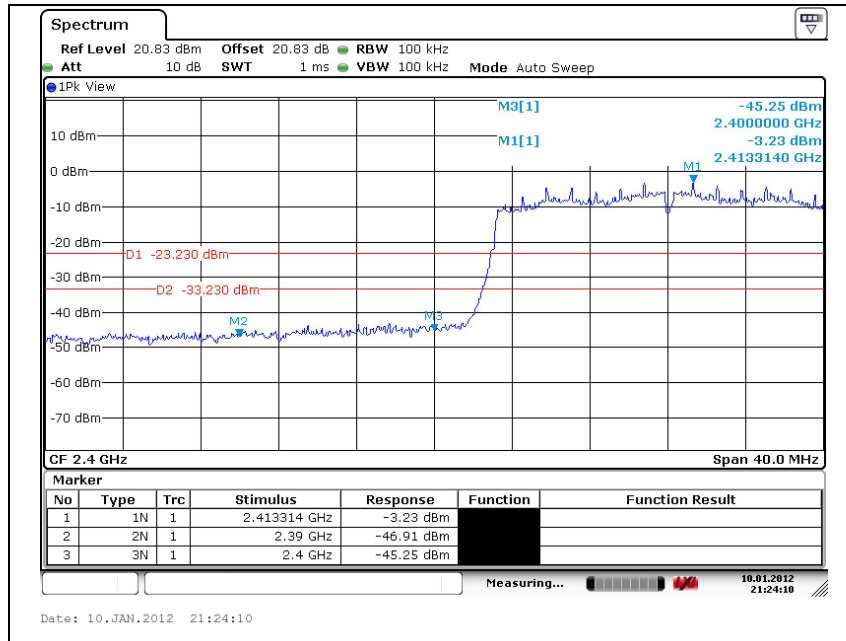

The results shown in this test report refer only to the sample(s) tested unless otherwise stated. This test report cannot be reproduced, except in full, without prior written permission of the Company.

Middle Channel

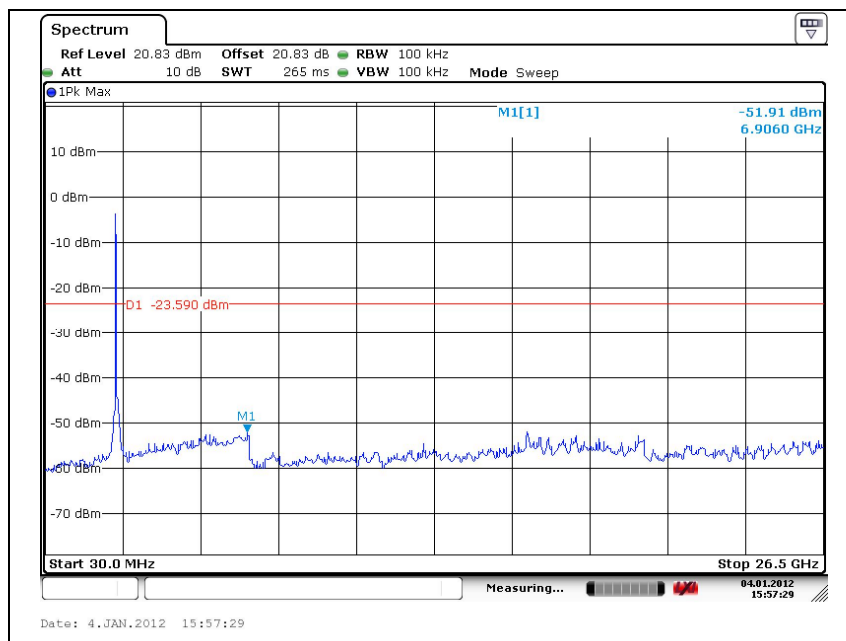
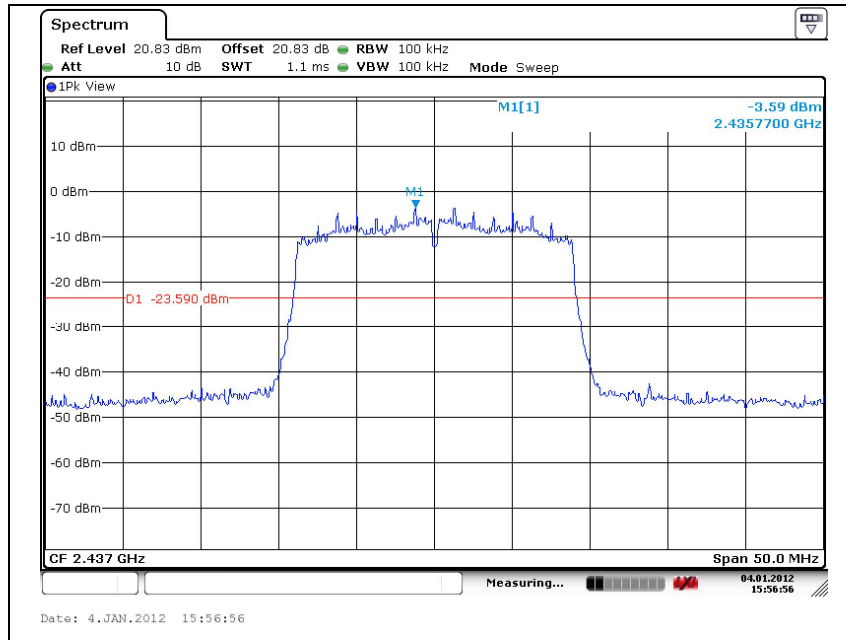

The results shown in this test report refer only to the sample(s) tested unless otherwise stated. This test report cannot be reproduced, except in full, without prior written permission of the Company.

High Channel

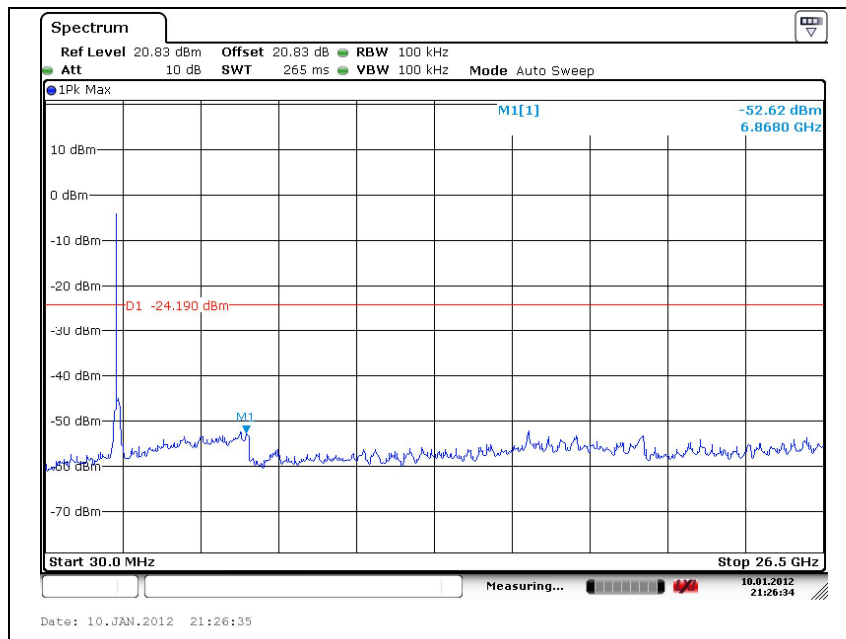
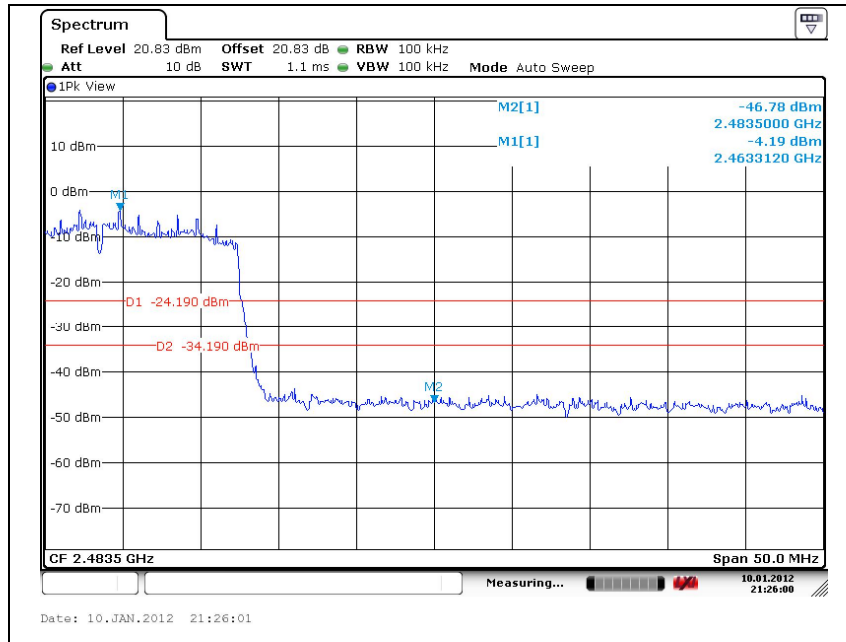

The results shown in this test report refer only to the sample(s) tested unless otherwise stated. This test report cannot be reproduced, except in full, without prior written permission of the Company.

3. 6 dB Bandwidth measurement

3.1. Test setup



3.2. Limit

According to §15.247(a)(2), systems using digital modulation techniques may operate in the 902 ~928 MHz , 2 400 ~ 2 483.5 MHz, and 5 725 ~ 5 825 MHz bands. The minimum of 6 dB Bandwidth shall be at least 500 kHz

3.3. Test procedure

1. The 6 dB band width was measured with a spectrum analyzer connected to RF antenna connector(conducted measurement) while EUT was operating in transmit mode at the appropriate center frequency. The analyzer center frequency was set to the EUT carrier frequency, using the analyzer. Display Line and Marker Delta functions, the 6 dB band width of the emission was determined.
2. The bandwidth of the fundamental frequency was measured with the spectrum analyzer
 2 GHz: RBW = 100 kHz, VBW = 100 kHz, Span = 50 MHz, Sweep = auto.

The results shown in this test report refer only to the sample(s) tested unless otherwise stated. This test report cannot be reproduced, except in full, without prior written permission of the Company.

3.4. Test result

Ambient temperature : (24 ± 2) °C
 Relative humidity : 47 % R.H.

Operation Mode	Frequency (MHz)	6 dB Bandwidth (MHz)	Limit (kHz)
DSSS 802.11b	2 412	8.47	More than 500 kHz
	2 437	9.05	
	2 462	8.61	
OFDM 802.11g	2 412	15.20	
	2 437	15.12	
	2 462	15.20	
OFDM 802.11n-HT20	2 412	16.93	
	2 437	16.93	
	2 462	16.93	

The results shown in this test report refer only to the sample(s) tested unless otherwise stated. This test report cannot be reproduced, except in full, without prior written permission of the Company.

DSSS : 802.11b

Low channel

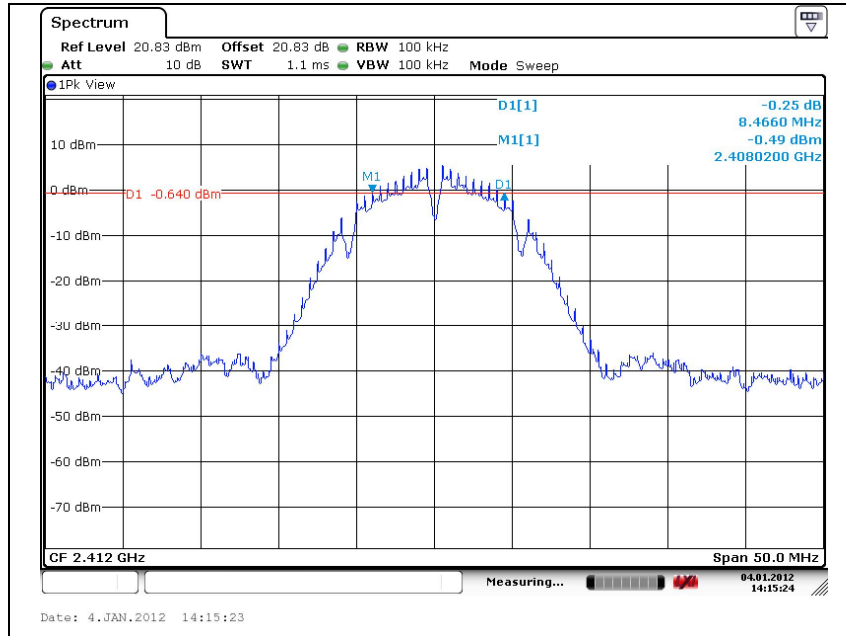

Middle channel

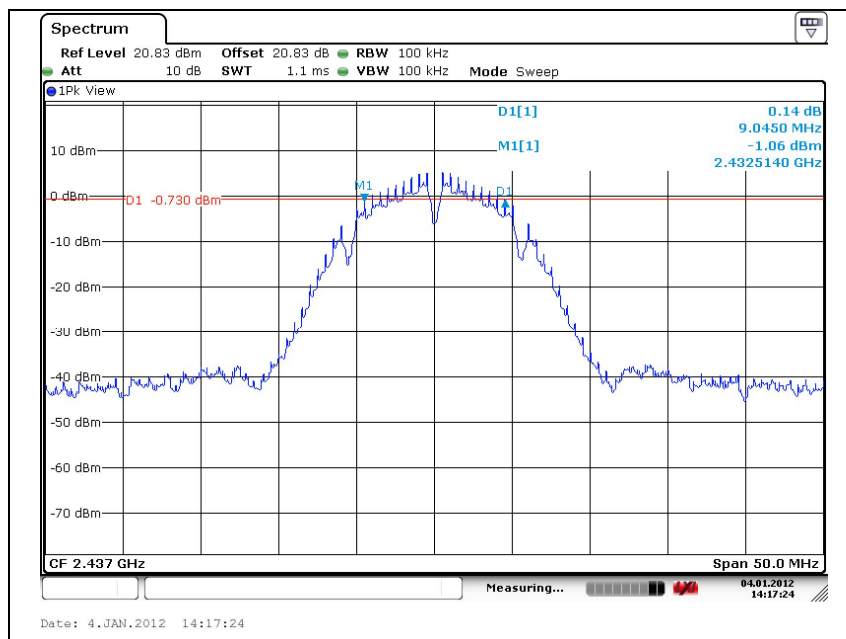

The results shown in this test report refer only to the sample(s) tested unless otherwise stated. This test report cannot be reproduced, except in full, without prior written permission of the Company.

High channel

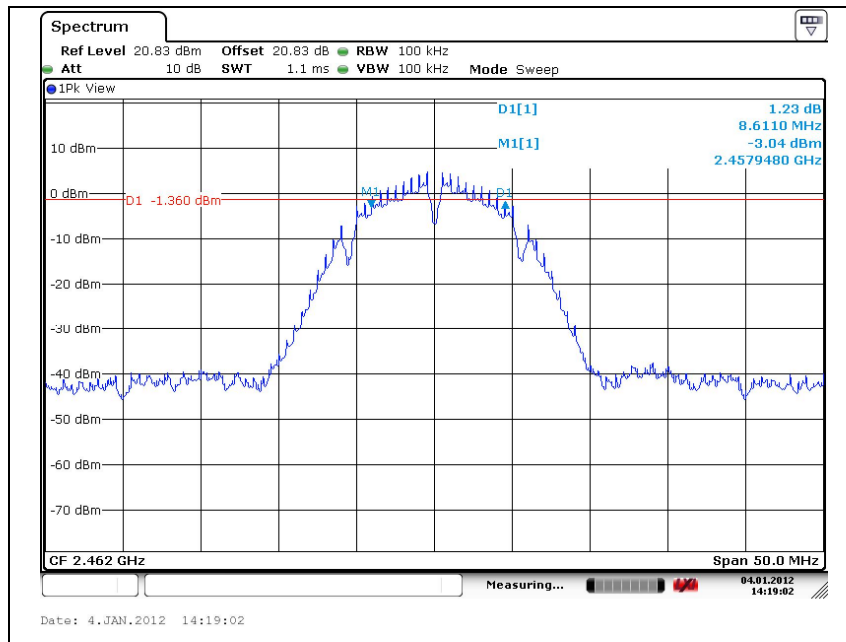

OFDM : 802.11g Low channel

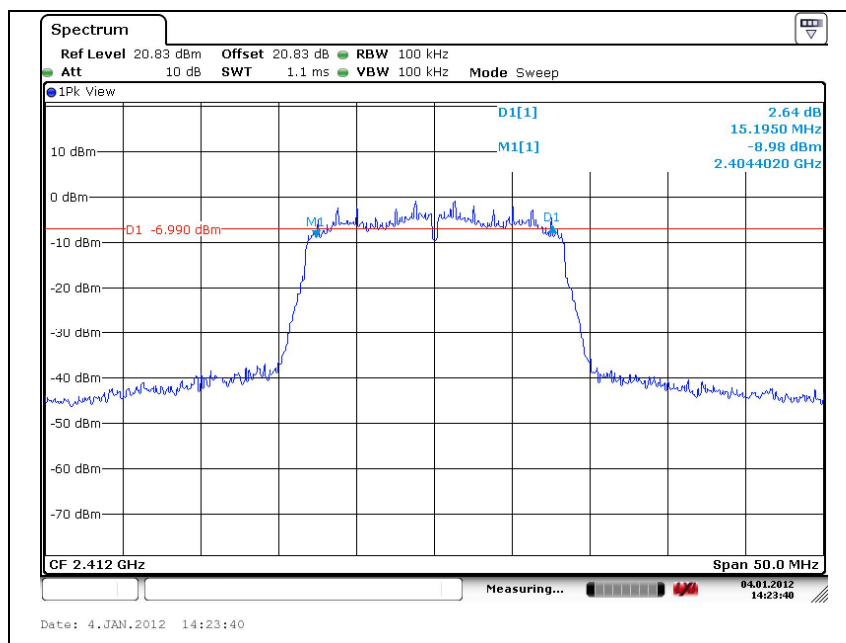

The results shown in this test report refer only to the sample(s) tested unless otherwise stated. This test report cannot be reproduced, except in full, without prior written permission of the Company.

Middle channel

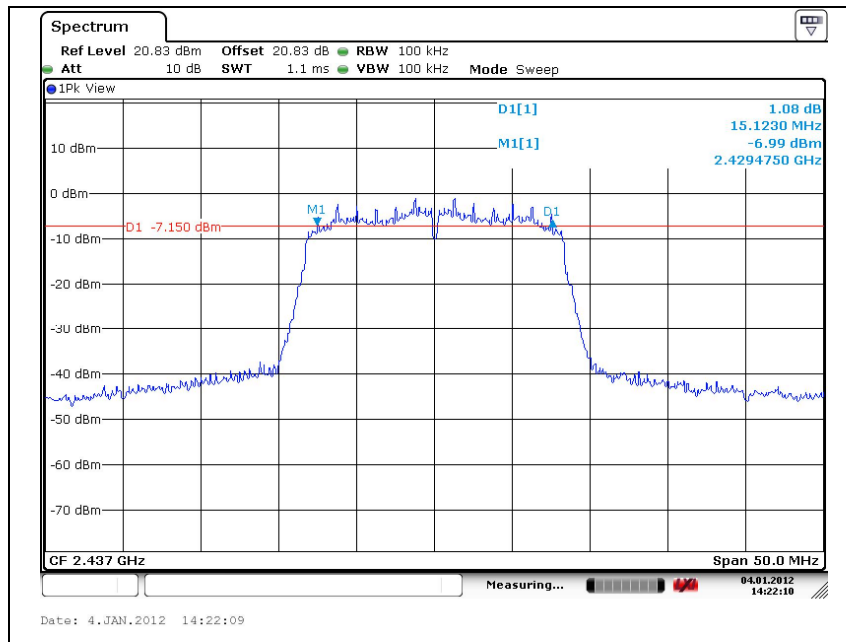

High channel

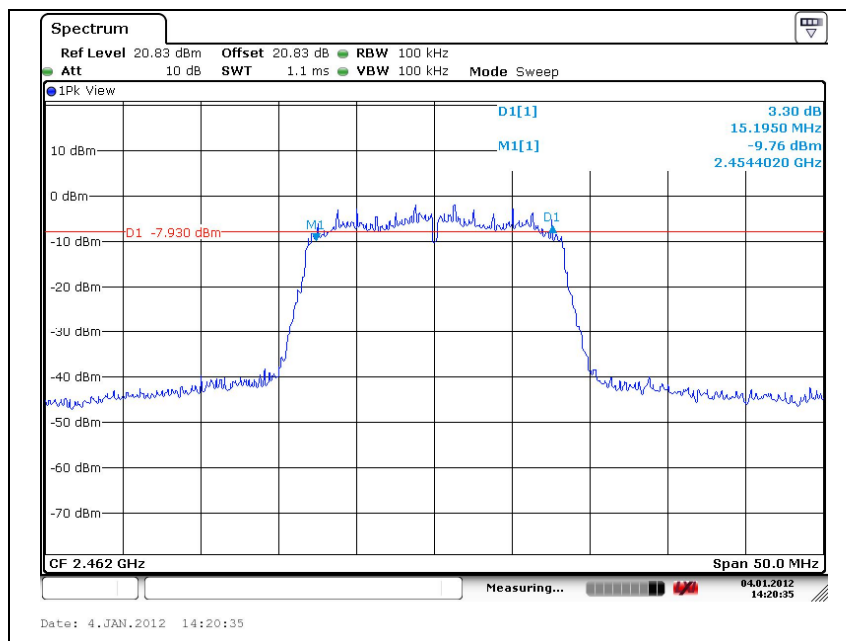

The results shown in this test report refer only to the sample(s) tested unless otherwise stated. This test report cannot be reproduced, except in full, without prior written permission of the Company.

OFDM : 802.11n-HT20 Low channel

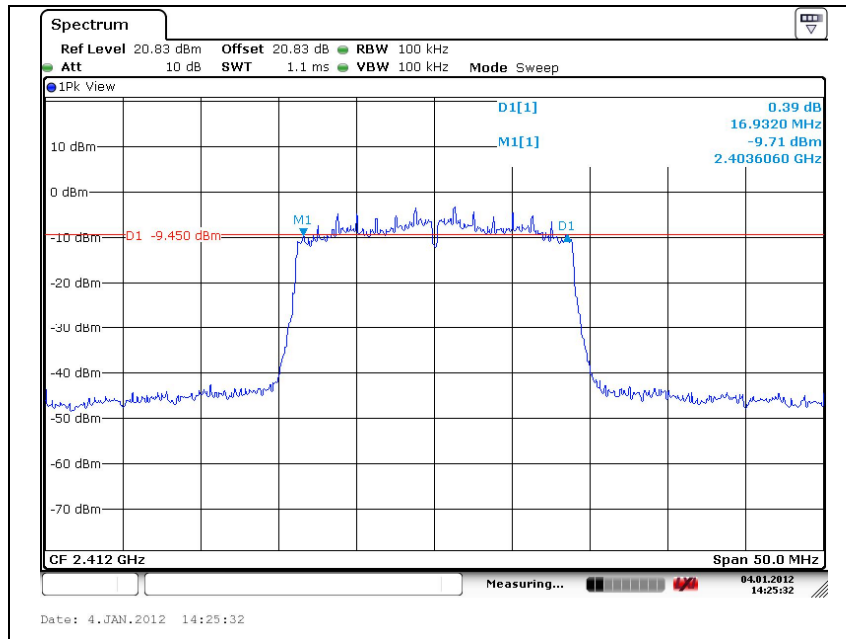

Middle channel

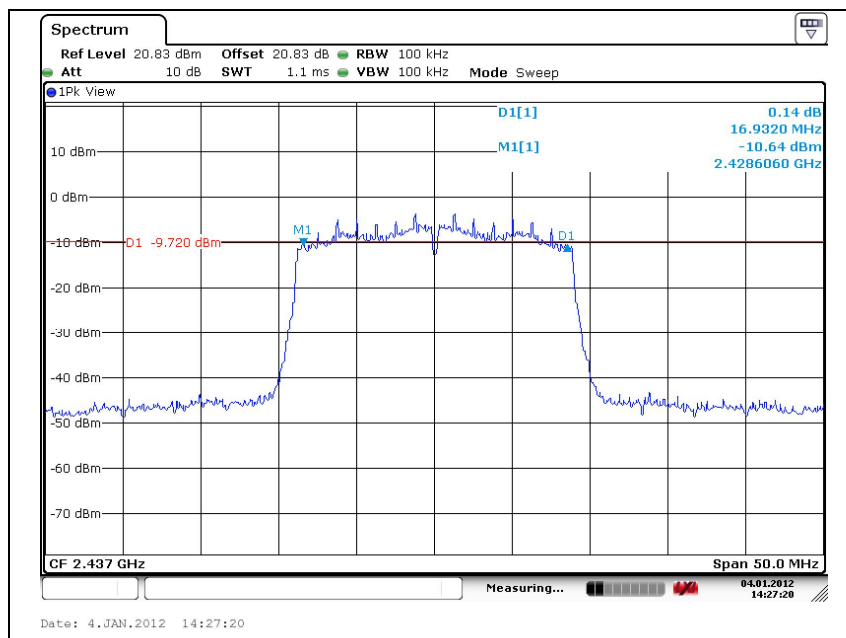

The results shown in this test report refer only to the sample(s) tested unless otherwise stated. This test report cannot be reproduced, except in full, without prior written permission of the Company.

High channel

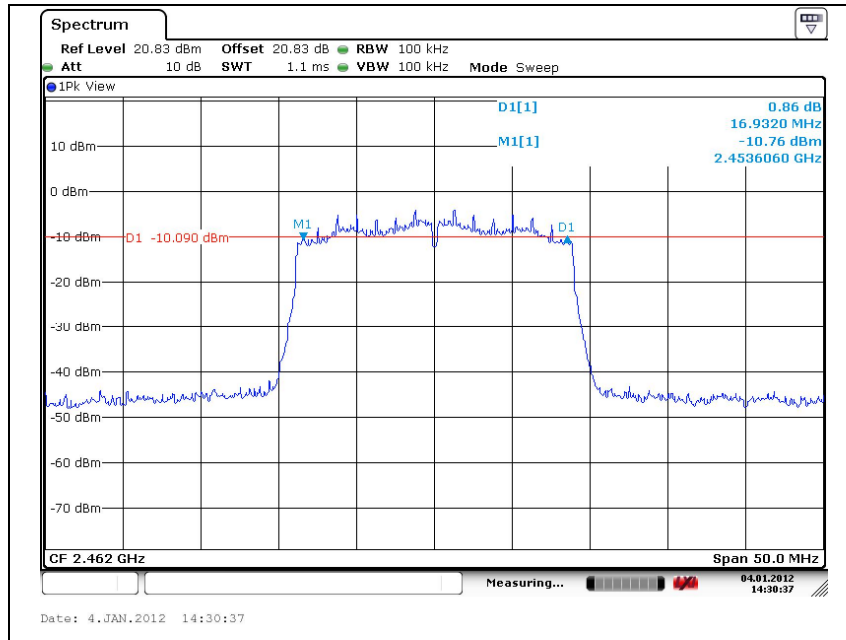

The results shown in this test report refer only to the sample(s) tested unless otherwise stated. This test report cannot be reproduced, except in full, without prior written permission of the Company.

4. Maximum peak output power measurement

4.1. Test setup

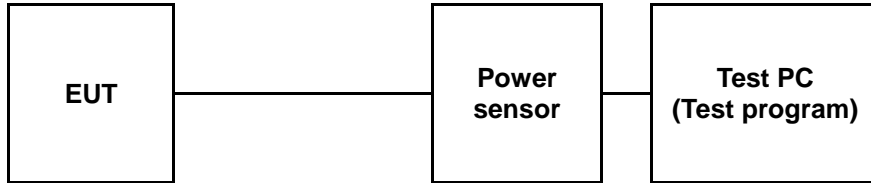

4.2. Limit

According to §15.247(b)(3), for systems using digital modulation in the 902 ~ 928 MHz, 2 400 ~2 483.5 MHz, and 5 725 ~ 5 850 MHz band: 1 Watt. As an alternative to a peak power measurement, compliance with the one watt limit can be based on a measurement of the maximum conducted output power. Maximum Conducted output Power is defined as the total transmit power delivered to all antennas and antenna elements averaged across all symbols in the signaling alphabet when the transmitter is operating at its maximum power control level. Power must be summed across all antenna elements. The average must not include any intervals during which the transmitter is off or is transmitting at a reduced power level. If multiple modes of operation are possible (e.g., alternative modulation methods), the maximum conducted output power is the highest total transmit power occurring in any mode.

According to §15.247(b)(4), the conducted output power limit specified in paragraph(b) of this section is based on the use of antenna with directional gains that do not exceed 6 dBi. Except as shown in paragraph(c) of this section, if transmitting antenna of directional gain greater than 6 dBi are used, the conducted output power from the intentional radiator shall be reduced below the stated values in paragraph (b)(1), (b)(2), and (b)(3) of this section , as appropriate, by the amount in dB that the directional gain of the antenna exceeds 6dBi.

4.3. Test procedure

1. Place the EUT on the table and set it in the transmitting mode.
2. Remove the antenna from the EUT and then connect a low loss RF cable from the antenna port to power sensor
3. Adjust the period of operating transmission in test program in order to use power sensor and then measure average power and peak power about each data rate of WLAN at the appropriate frequencies.
4. Record in the test report.

The results shown in this test report refer only to the sample(s) tested unless otherwise stated. This test report cannot be reproduced, except in full, without prior written permission of the Company.

4.4. Test result

Ambient temperature : (24 ± 2) °C

Relative humidity : 47 % R.H.

Mode	Channel Frequency (MHz)	Channel	Data rate (Mbps)	Attenuator + Cable offset (dB)	Average power Result (dB m)	Peak Power Result (dB m)
DSSS (802.11b)	2 412	Low	1	21.54	14.16	<u>17.41</u>
			2		14.06	17.05
			5.5		14.14	17.00
			11		13.83	17.23
	2 437	Middle	1	21.66	13.94	<u>17.87</u>
			2		13.90	17.15
			5.5		13.93	16.83
			11		13.67	17.03
	2 462	High	1	21.72	13.41	<u>16.77</u>
			2		13.37	16.55
			5.5		13.36	16.53
			11		13.28	16.68
OFDM (802.11g)	2 412	Low	6	21.54	10.11	<u>21.91</u>
			9		9.94	21.40
			12		9.79	20.77
			18		9.55	21.42
			24		9.35	20.80
			36		8.94	21.44
			48		8.59	21.14
			54		8.46	20.80
	2 437	Middle	6	21.66	10.04	<u>21.60</u>
			9		9.88	21.47
			12		9.78	21.27
			18		9.53	21.52
			24		9.22	20.75
			36		8.81	21.49
			48		8.46	21.21
			54		8.33	20.85
	2 462	High	6	21.72	9.59	<u>21.99</u>
			9		9.57	21.98
			12		9.38	20.57
			18		9.08	21.60
			24		9.01	21.44
			36		8.61	21.36
			48		8.28	20.96
			54		8.14	20.74

The results shown in this test report refer only to the sample(s) tested unless otherwise stated. This test report cannot be reproduced, except in full, without prior written permission of the Company.

Mode	Channel Frequency (MHz)	Channel	Data rate (Mbps)	Attenuator + Cable offset (dB)	Average power Result (dB m)	Peak Power Result (dB m)
OFDM (802.11n)	2 412	Low	MCS0	21.54	8.44	<u>19.85</u>
			MCS1		7.62	19.74
			MCS2		7.40	19.41
			MCS3		7.20	19.38
			MCS4		6.82	19.25
			MCS5		6.50	19.05
			MCS6		6.36	19.51
			MCS7		6.19	19.38
	2 437	Middle	MCS0	21.66	7.78	<u>19.87</u>
			MCS1		7.42	19.86
			MCS2		7.34	19.24
			MCS3		6.96	18.95
			MCS4		6.60	19.18
			MCS5		6.26	19.30
			MCS6		6.16	19.44
			MCS7		6.03	19.38
	2 462	High	MCS0	21.72	7.28	<u>19.55</u>
			MCS1		7.03	19.54
			MCS2		6.80	18.92
			MCS3		6.59	18.93
			MCS4		5.92	18.59
			MCS5		5.60	18.65
			MCS6		5.50	19.02
			MCS7		5.36	18.81

The results shown in this test report refer only to the sample(s) tested unless otherwise stated. This test report cannot be reproduced, except in full, without prior written permission of the Company.

5. Power spectral density measurement

5.1. Test setup



5.2. Limit

According to §15.247(e), For digitally modulated system, the power spectral density conducted from the intentional radiator to the antenna shall not be greater than 8 dBm in any 3 kHz band any time interval of continuous transmission. This power spectral density shall be determined in accordance with the provisions of paragraph(b) of this section. The same method of determining the conducted output power shall be used to determine the power spectral density

5.3. Test procedure

1. Place the EUT on the table and set it in transmitting mode
Remove the antenna from the EUT and then connect a low loss RF cable from the antenna port to the spectrum analyzer.
2. Set the spectrum analyzer as RBW = 3 kHz, VBW = 10 kHz, Span = 300 kHz, Sweep = 100 s
3. Record the max reading.
4. Repeat the above procedure until the measurements for all frequencies are completed.

The results shown in this test report refer only to the sample(s) tested unless otherwise stated. This test report cannot be reproduced, except in full, without prior written permission of the Company.

5.4. Test result

Ambient temperature : (24 ± 2) °C
 Relative humidity : 47 % R.H.

Operation Mode	Frequency (MHz)	Final RF Power Level in 3 kHz BW (dB m)	Limit (dB m)
DSSS 802.11b	2 412	-8.49	8
	2 437	-8.44	
	2 462	-8.93	
OFDM 802.11g	2 412	-15.52	
	2 437	-15.52	
	2 462	-15.57	
OFDM 802.11n-HT20	2 412	-16.56	
	2 437	-16.78	
	2 462	-17.10	

The results shown in this test report refer only to the sample(s) tested unless otherwise stated. This test report cannot be reproduced, except in full, without prior written permission of the Company.

DSSS : 802.11b

Low channel

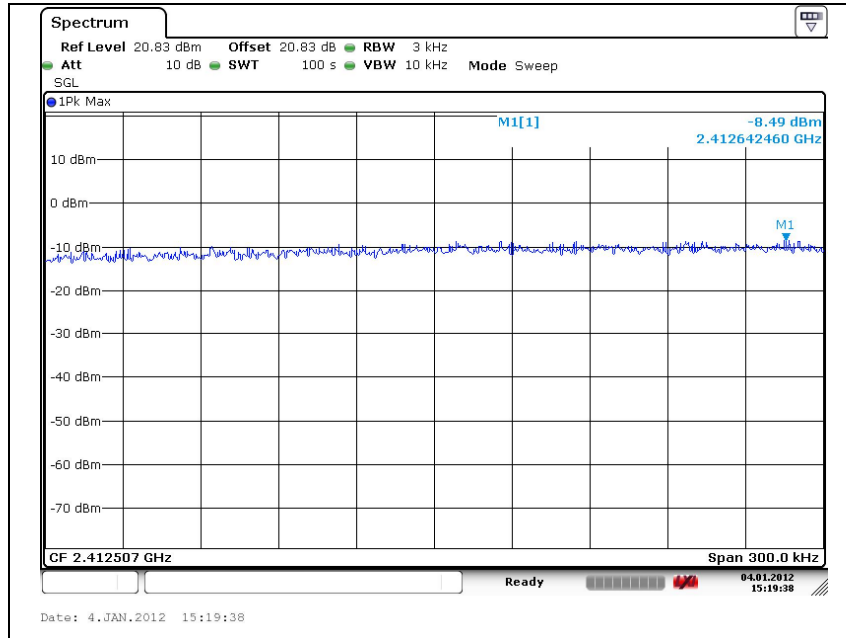

Middle channel

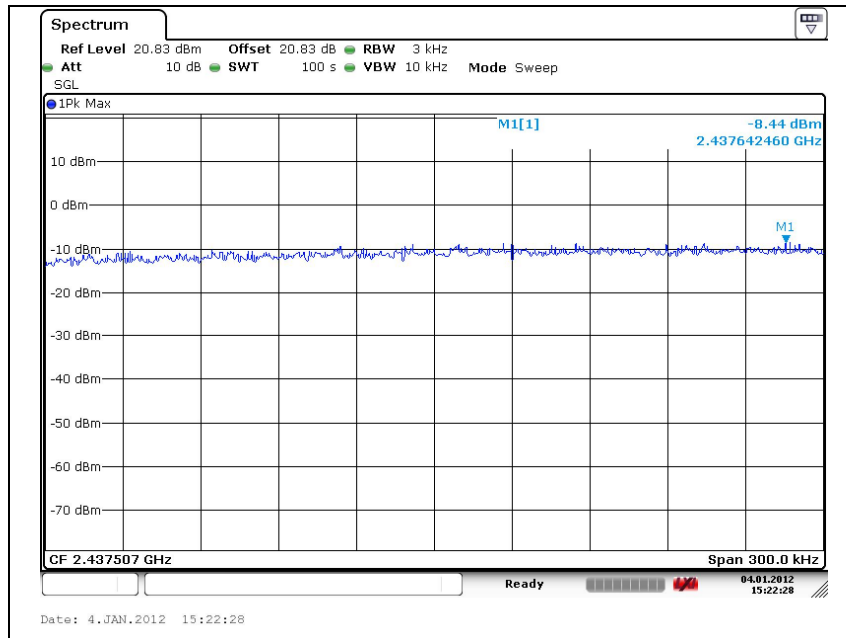

The results shown in this test report refer only to the sample(s) tested unless otherwise stated. This test report cannot be reproduced, except in full, without prior written permission of the Company.

High channel

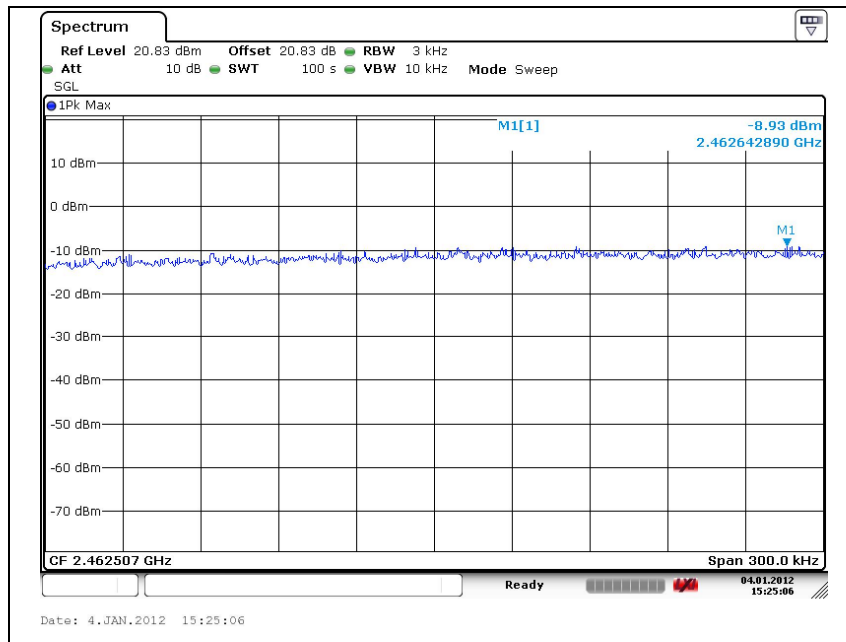

OFDM : 802.11g

Low channel

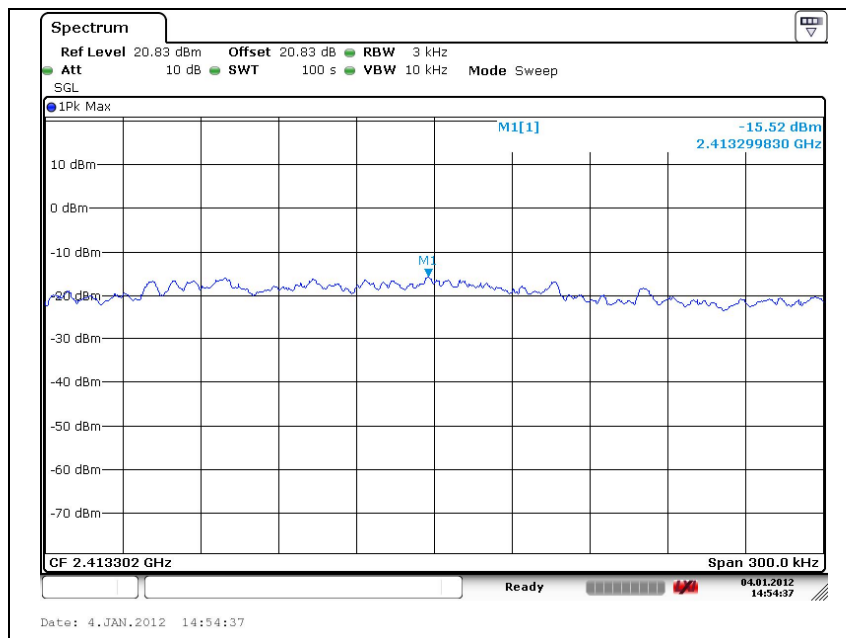

The results shown in this test report refer only to the sample(s) tested unless otherwise stated. This test report cannot be reproduced, except in full, without prior written permission of the Company.

Middle channel

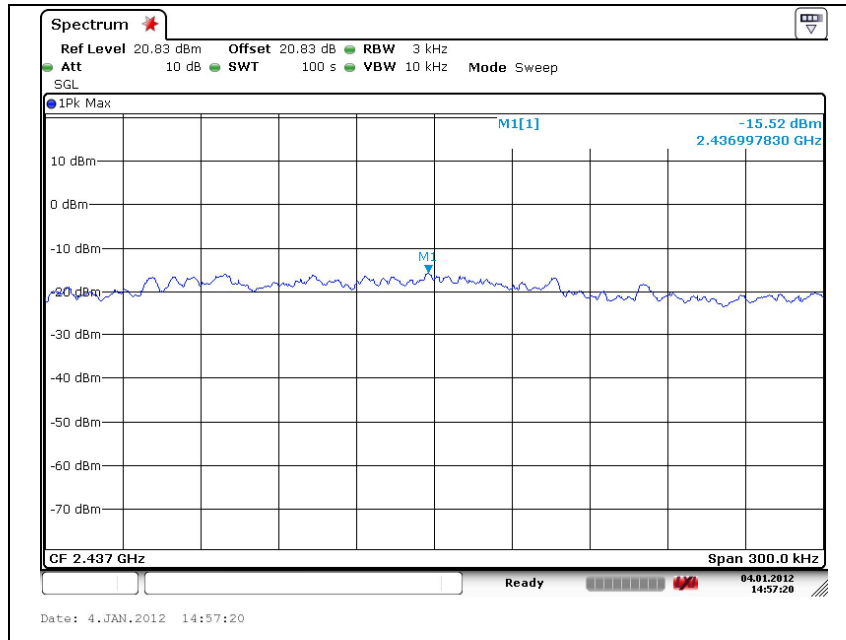

High channel

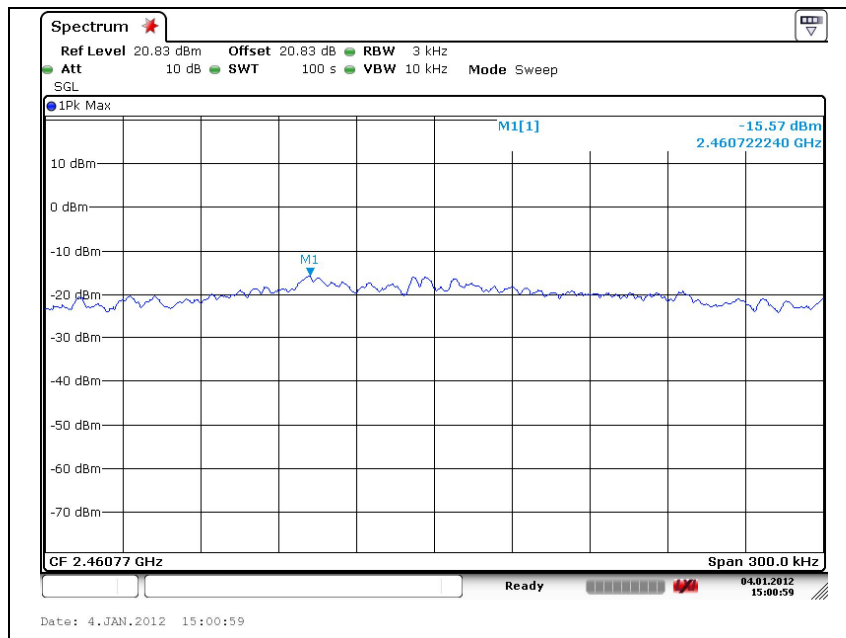

The results shown in this test report refer only to the sample(s) tested unless otherwise stated. This test report cannot be reproduced, except in full, without prior written permission of the Company.

OFDM : 802.11n-HT20

Low channel

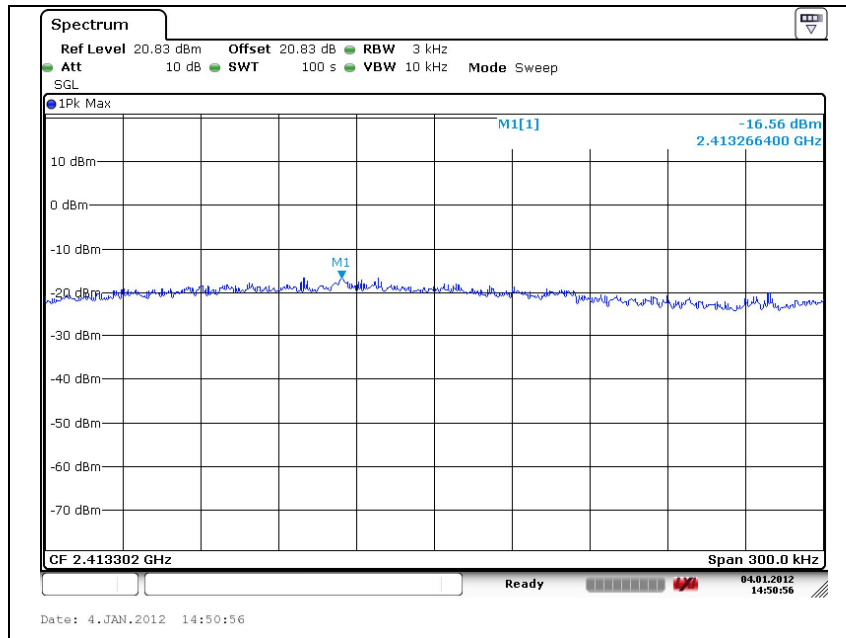

Middle channel

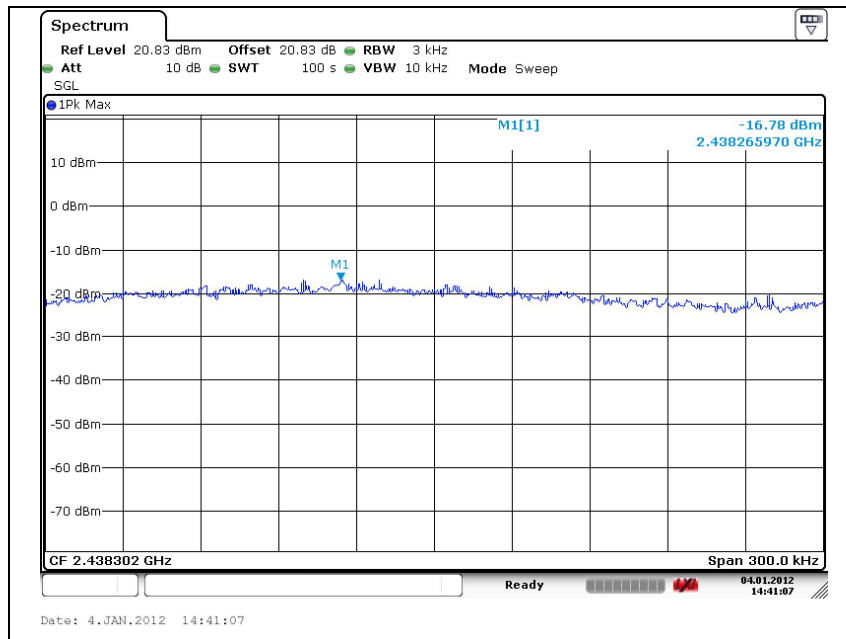

The results shown in this test report refer only to the sample(s) tested unless otherwise stated. This test report cannot be reproduced, except in full, without prior written permission of the Company.

High channel

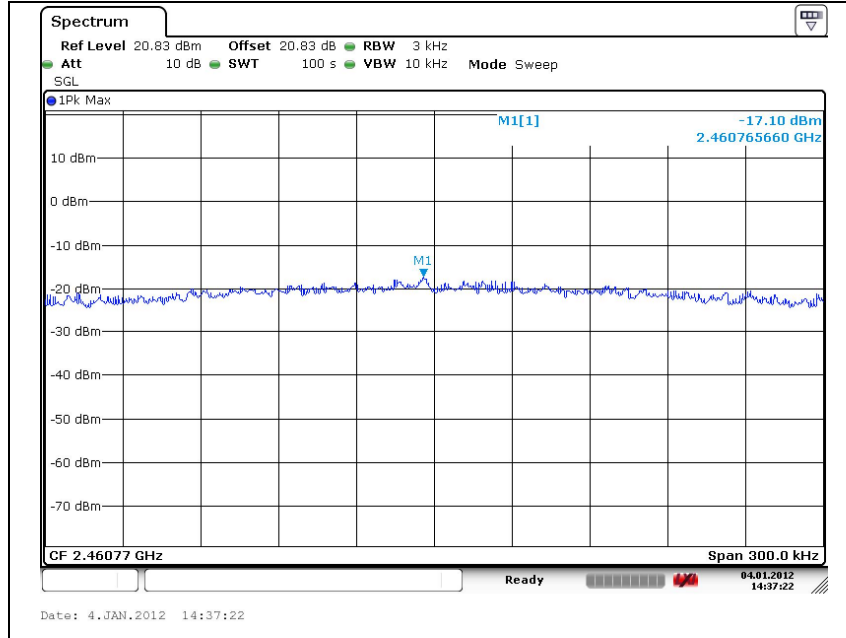

The results shown in this test report refer only to the sample(s) tested unless otherwise stated. This test report cannot be reproduced, except in full, without prior written permission of the Company.

6. Transmitter AC power line conducted emission

6.1. Test setup

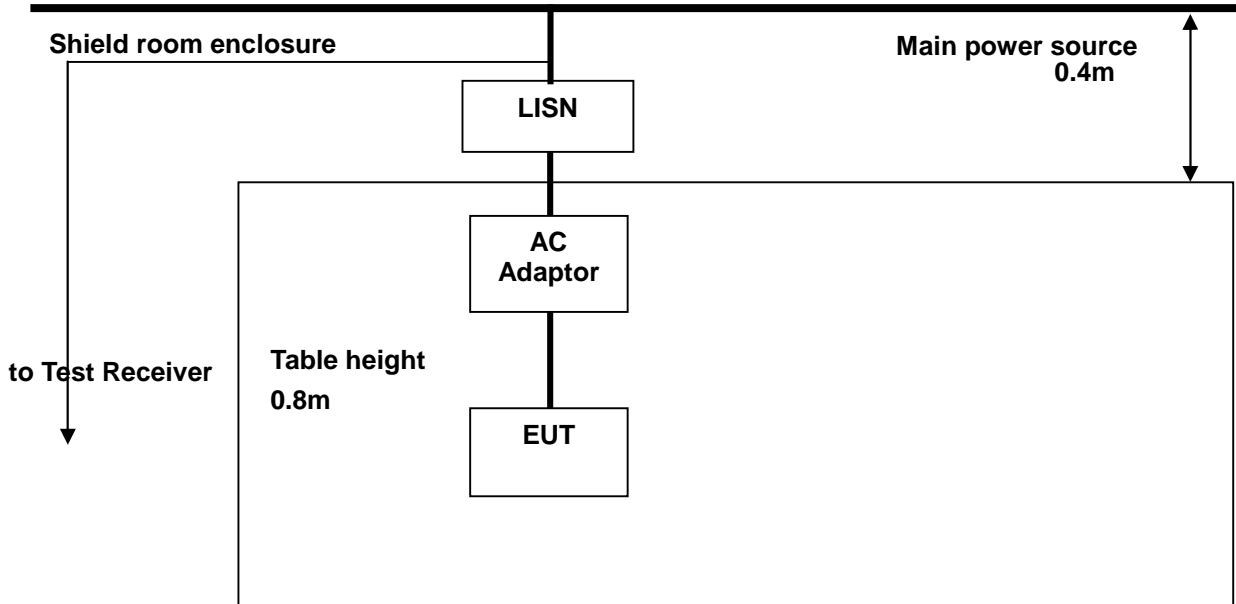

6.2. Limit

According to §15.207(a) for an intentional radiator that is designed to be connected to the public utility (AC) power line, the radio frequency voltage that is conducted back onto the AC power line on any frequency or frequencies, within the band 150 kHz to 30 MHz, shall not exceed the limits in the following table, as measured using a 50 uH/50 ohm line impedance stabilization network(LISN).

Compliance with the provision of this paragraph shall on the measurement of the radio frequency voltage between each power line and ground at the power terminal. The lower applies at the boundary between the frequency ranges.

Frequency of Emission (MHz)	Conducted limit (dB µV)	
	Quasi-peak	Average
0.15 – 0.50	66-56*	56-46*
0.50 – 5.00	56	46
5.00 – 30.0	60	50

■ Decreases with the logarithm of the frequency.

The results shown in this test report refer only to the sample(s) tested unless otherwise stated. This test report cannot be reproduced, except in full, without prior written permission of the Company.

6.3. Test procedures

Radiated emissions from the EUT were measured according to the dictates of ANSI C63.4:2003

1. The test procedure is performed in a 6.5 m × 3.6 m × 3.6 m (L×W×H) shielded room. The EUT along with its peripherals were placed on a 1.0 m(W)× 1.5 m(L) and 0.8 m in height wooden table and the EUT was adjusted to maintain a 0.4 meter space from a vertical reference plane.
2. The EUT was connected to power mains through a line impedance stabilization network (LISN) which provides 50 ohm coupling impedance for measuring instrument and the chassis ground was bounded to the horizontal ground plane of shielded room.
3. All peripherals were connected to the second LISN and the chassis ground also bounded to the horizontal ground plane of shielded room.
4. The excess power cable between the EUT and the LISN was bundled. The power cables of peripherals were unbundled. All connecting cables of EUT and peripherals were moved to find the maximum emission.

The results shown in this test report refer only to the sample(s) tested unless otherwise stated. This test report cannot be reproduced, except in full, without prior written permission of the Company.

6.4. Test result (Worst case configuration_802.11g)

The following table shows the highest levels of conducted emissions on both phase of Hot and Neutral line.

Ambient temperature : (24 ± 2) °C
 Relative humidity : 47 % R.H.

 Frequency range : 0.15 MHz – 30 MHz
 Measured Bandwidth : 9 kHz

Freq. (MHz)	Level (dB uV)		Line	Limit (dB uV)		Margin (dB)	
	Q-Peak	Average		Q-Peak	Average	Q-Peak	Average
0.20	34.37	18.43	H	63.61	53.61	29.24	35.18
0.29	33.78	18.88	H	60.52	50.52	26.74	31.64
0.99	28.66	19.73	H	56.00	46.00	27.34	26.27
3.30	26.53	18.03	H	56.00	46.00	29.47	27.97
4.45	34.73	26.15	H	56.00	46.00	21.27	19.85
12.18	32.85	23.49	H	60.00	50.00	27.15	26.51
0.46	36.02	25.20	N	56.69	46.69	20.67	21.49
0.56	33.75	20.53	N	56.00	46.00	22.25	25.47
0.96	31.91	22.08	N	56.00	46.00	24.09	23.92
3.67	32.76	24.18	N	56.00	46.00	23.24	21.82
3.84	33.93	25.91	N	56.00	46.00	22.07	20.09
4.21	37.39	29.16	N	56.00	46.00	18.61	16.84

■ Note

Line (H) : Hot
 Line (N) : Neutral

The results shown in this test report refer only to the sample(s) tested unless otherwise stated. This test report cannot be reproduced, except in full, without prior written permission of the Company.

Plot of conducted power line

Test mode: (Hot)

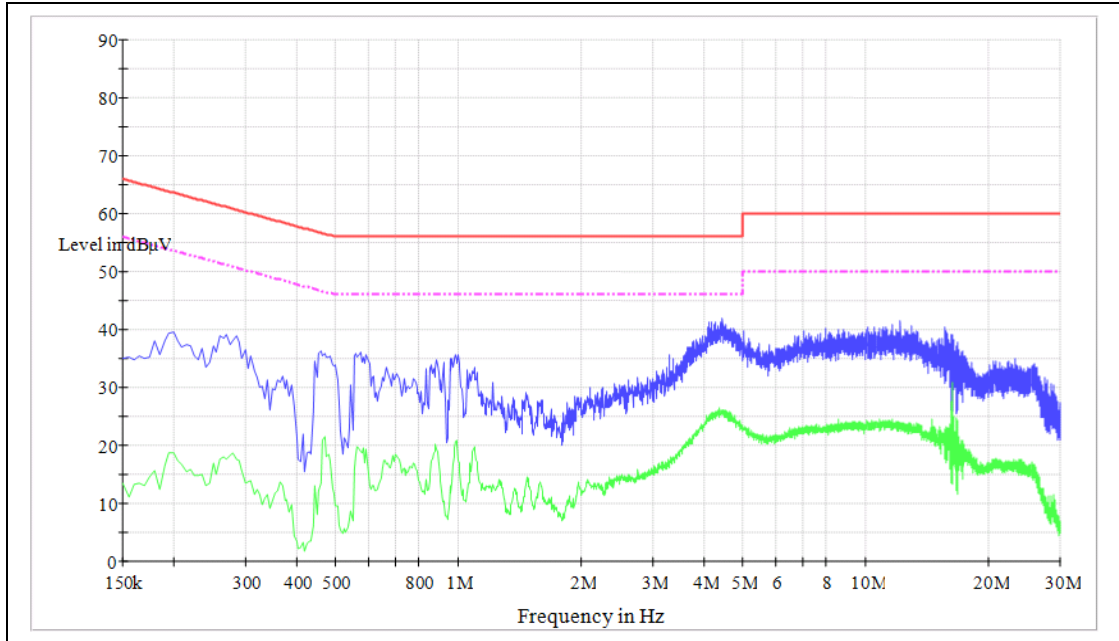

The results shown in this test report refer only to the sample(s) tested unless otherwise stated. This test report cannot be reproduced, except in full, without prior written permission of the Company.

Test mode: (Neutral)

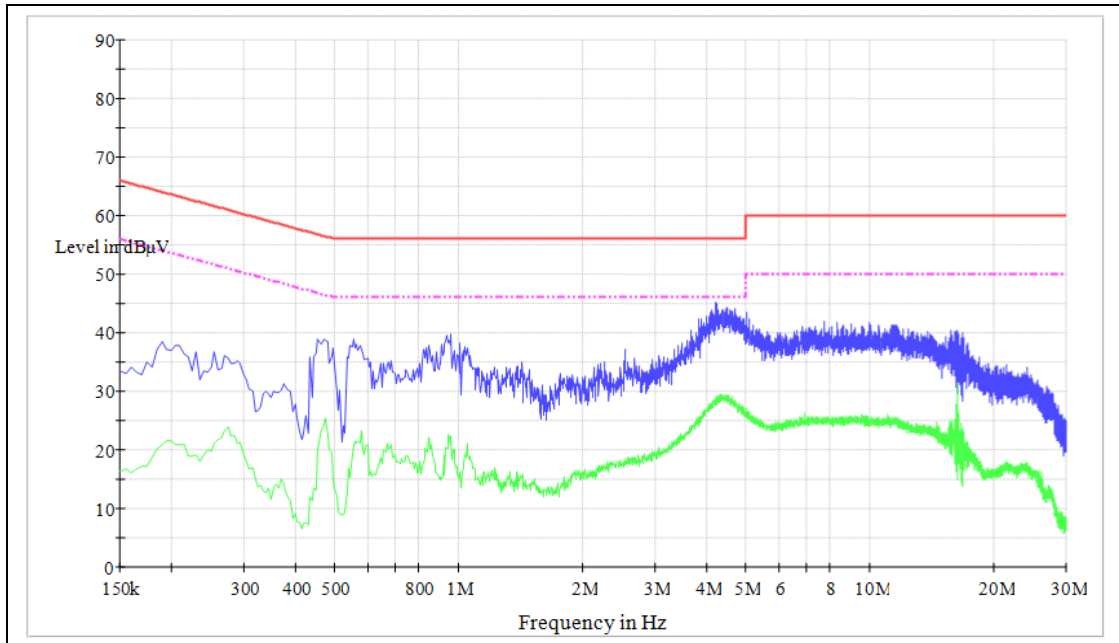

The results shown in this test report refer only to the sample(s) tested unless otherwise stated. This test report cannot be reproduced, except in full, without prior written permission of the Company.

7. Antenna Requirement

7.1. Standard Applicable

For intentional device, according to FCC 47 CFR Section §15.203, an intentional radiator shall be designed to ensure that no antenna other than that furnished by the responsible party shall be used with the device. And according to FCC 47 CFR Section § 15.247 (b), if transmitting antennas of directional gain greater than 6 dBi are used, the power shall be reduced by the amount in dB that the gain of the antenna exceeds 6 dBi.

7.2. Antenna Connected Construction

The antenna used of this product is Fixed type antenna.
The peak max gain of this antenna is -0.69 dBi.

The results shown in this test report refer only to the sample(s) tested unless otherwise stated. This test report cannot be reproduced, except in full, without prior written permission of the Company.

SGS Korea Co., Ltd. (Gunpo Laboratory) 18-34, Sanbon-dong, Gunpo-si, Gyeonggi-do, Korea, 435-040

Tel. +82 31 428 5700 / Fax. +82 31 427 2371

www.kr.sgs.com/ee