



FCC CFR47 PART 15 SUBPART C

CERTIFICATION TEST REPORT

FOR

**BT3.0+HS,802.11BGN 1X1 HT20, GSM & WCDMA850/1900MHZ BAR PHONE
W/HOTSPOT,EDGE RX ONLY**

MODEL NUMBER: GT-B5330B

FCC ID: A3LGTB5330B

REPORT NUMBER: 12I14430-2, REVISION A

ISSUE DATE: JUNE 28, 2012

Prepared for

**SAMSUNG ELECTRONICS CO., LTD.
416, MAETAN 3-DONG, YEONGTONG-GU
SUWON-CITY, GYEONGGI-DO 443-742, SOUTH KOREA**

Prepared by

**COMPLIANCE CERTIFICATION SERVICES (UL CCS)
47173 BENICIA STREET
FREMONT, CA 94538, U.S.A.
TEL: (510) 771-1000
FAX: (510) 661-0888**



NVLAP LAB CODE 200065-0

Revision History

<u>Rev.</u>	<u>Issue Date</u>	<u>Revisions</u>	<u>Revised By</u>
	06/06/2012	Original	T. LEE
A	06/28/2012	Corrected AFH channels	T. LEE

TABLE OF CONTENTS

1. ATTESTATION OF TEST RESULTS	5
2. TEST METHODOLOGY	6
3. FACILITIES AND ACCREDITATION	6
4. CALIBRATION AND UNCERTAINTY	6
4.1. <i>MEASURING INSTRUMENT CALIBRATION</i>	6
4.2. <i>SAMPLE CALCULATION</i>	6
4.3. <i>MEASUREMENT UNCERTAINTY</i>	6
5. EQUIPMENT UNDER TEST	7
5.1. <i>DESCRIPTION OF EUT</i>	7
5.2. <i>MAXIMUM OUTPUT POWER</i>	7
5.3. <i>DESCRIPTION OF AVAILABLE ANTENNAS</i>	7
5.4. <i>SOFTWARE AND FIRMWARE</i>	7
5.5. <i>WORST-CASE CONFIGURATION AND MODE</i>	8
5.6. <i>DESCRIPTION OF TEST SETUP</i>	9
6. TEST AND MEASUREMENT EQUIPMENT	12
7. ANTENNA PORT TEST RESULTS	13
7.1. <i>BASIC DATA RATE GFSK MODULATION</i>	13
7.1.1. 20 dB BANDWIDTH	13
7.1.2. HOPPING FREQUENCY SEPARATION	16
7.1.3. NUMBER OF HOPPING CHANNELS.....	18
7.1.4. AVERAGE TIME OF OCCUPANCY	21
7.1.5. OUTPUT POWER	25
7.1.6. AVERAGE POWER	28
7.1.7. CONDUCTED SPURIOUS EMISSIONS.....	29
7.2. <i>ENHANCED DATA RATE 8PSK MODULATION</i>	34
7.2.1. 20 dB BANDWIDTH	34
7.2.2. HOPPING FREQUENCY SEPARATION	37
7.2.3. NUMBER OF HOPPING CHANNELS.....	39
7.2.4. AVERAGE TIME OF OCCUPANCY	42
7.2.5. OUTPUT POWER	46
7.2.6. AVERAGE POWER	49
7.2.7. CONDUCTED SPURIOUS EMISSIONS.....	50
8. RADIATED TEST RESULTS	55
8.1. <i>LIMITS AND PROCEDURE</i>	55
8.2. <i>TRANSMITTER ABOVE 1 GHz</i>	56
8.2.1. BASIC DATA RATE GFSK MODULATION.....	56

8.2.2.	ENHANCED DATA RATE 8PSK MODULATION	61
8.3.	WORST-CASE BELOW 1 GHz	66
9.	AC POWER LINE CONDUCTED EMISSIONS	69
10.	MAXIMUM PERMISSIBLE EXPOSURE	73
11.	SETUP PHOTOS	77

1. ATTESTATION OF TEST RESULTS

COMPANY NAME: SAMSUNG ELECTRONICS CO., LTD.
416, MAETAN 3-DONG, YEONGTONG-GU
SUWON-CITY, GYEONGGI-DO 443-742, SOUTH KOREA

EUT DESCRIPTION: BT3.0, 802.11 B/G/N 1X1 HT20, GSM850/1900, WCDMA850MHZ,
BAR PHONE WITH HOTSPOTS. AND VOIP SUPPORTED

MODEL: GT-B5330B

SERIAL NUMBER: FJ-154-C (CONDUCTED), FJ-154-D (RADIATED)

DATE TESTED: MAY 31-JUNE 02,, 2012

APPLICABLE STANDARDS	
STANDARD	TEST RESULTS
CFR 47 Part 15 Subpart C	Pass

Compliance Certification Services (UL CCS) tested the above equipment in accordance with the requirements set forth in the above standards. All indications of Pass/Fail in this report are opinions expressed by UL CCS based on interpretations and/or observations of test results. Measurement Uncertainties were not taken into account and are published for informational purposes only. The test results show that the equipment tested is capable of demonstrating compliance with the requirements as documented in this report.

Note: The results documented in this report apply only to the tested sample, under the conditions and modes of operation as described herein. This document may not be altered or revised in any way unless done so by UL CCS and all revisions are duly noted in the revisions section. Any alteration of this document not carried out by UL CCS will constitute fraud and shall nullify the document. This report must not be used by the client to claim product certification, approval, or endorsement by NVLAP, NIST, any agency of the Federal Government, or any agency of any government.

Approved & Released For UL CCS By:

Tested By:



TIM LEE
STAFF ENGINEER
UL CCS

CHIN PANG
EMC ENGINEER
UL CCS

2. TEST METHODOLOGY

The tests documented in this report were performed in accordance with ANSI C63.10-2009, FCC CFR 47 Part 2, and FCC CFR 47 Part 15.

3. FACILITIES AND ACCREDITATION

The test sites and measurement facilities used to collect data are located at 47173 Benicia Street, Fremont, California, USA.

UL CCS is accredited by NVLAP, Laboratory Code 200065-0. The full scope of accreditation can be viewed at <http://www.ccsemc.com>.

4. CALIBRATION AND UNCERTAINTY

4.1. MEASURING INSTRUMENT CALIBRATION

The measuring equipment utilized to perform the tests documented in this report has been calibrated in accordance with the manufacturer's recommendations, and is traceable to recognized national standards.

4.2. SAMPLE CALCULATION

Where relevant, the following sample calculation is provided:

$$\begin{aligned} \text{Field Strength (dBuV/m)} &= \text{Measured Voltage (dBuV)} + \text{Antenna Factor (dB/m)} + \\ &\text{Cable Loss (dB)} - \text{Preamp Gain (dB)} \\ 36.5 \text{ dBuV} + 18.7 \text{ dB/m} + 0.6 \text{ dB} - 26.9 \text{ dB} &= 28.9 \text{ dBuV/m} \end{aligned}$$

4.3. MEASUREMENT UNCERTAINTY

Where relevant, the following measurement uncertainty levels have been estimated for tests performed on the apparatus:

PARAMETER	UNCERTAINTY
Conducted Disturbance, 0.15 to 30 MHz	3.52 dB
Radiated Disturbance, 30 to 1000 MHz	4.94 dB

Uncertainty figures are valid to a confidence level of 95%.

5. EQUIPMENT UNDER TEST

5.1. DESCRIPTION OF EUT

The EUT is BT3.0, 802.11 B/G/N 1X1 HT20, GSM850/1900, WCDMA850MHZ, Bar Phone with HOTSPOTS. AND VOIP supported.

The radio module is manufactured by Samsung Electronics Co., Ltd.

The unit supports AFH mode. The manufacturer attested the following.

- It is in compliance with Bluetooth Specification 1.2 or later specification.
- The number of hopping channel in AFH mode is 20 channels
- The output power do not transmit over than 125 mW
- The channel separation is based upon 2/3 of 20 dB channel bandwidth

5.2. MAXIMUM OUTPUT POWER

The transmitter has a maximum peak conducted output power as follows:

Frequency Range (MHz)	Mode	Output Power (dBm)	Output Power (mW)
2402 - 2480	Basic GFSK	10.57	11.40
2402 - 2480	Enhanced 8PSK	10.16	10.38

5.3. DESCRIPTION OF AVAILABLE ANTENNAS

The radio utilizes a PIFA antenna, with a maximum gain of -0.7 dBi.

5.4. SOFTWARE AND FIRMWARE

The firmware installed in the EUT during testing was BT Test Engineering Mode.

5.5. WORST-CASE CONFIGURATION AND MODE

Radiated emission below 1 GHz and power line conducted emission tests were performed with the EUT transmitting at the channel with highest output power as worst-case scenario.

The fundamental frequency was investigated for the EUT in three orthogonal orientations X,Y, and Z (battery-operated), also for EUT with AC/DC adapter and with headset connected; it was found that the worst-case orientation among them was X orientation with AC/DC adapter and with headset. All final radiated emission testing was performed using the worst-case orientation.

5.6. DESCRIPTION OF TEST SETUP

SUPPORT EQUIPMENT

Band	Mode	Separation Distance (m)	Output AV Power (dBm)	Antenna Gain (dBi)	IC Power Density (W/m ²)	FCC Power Density (mW/cm ²)
2.4 GHz	Bluetooth	0.20	10.00	-0.70	0.017	0.0017

I/O CABLES (CONDUCTED SETUP)

I/O CABLE LIST						
Cable No.	Port	# of Identical Ports	Connector Type	Cable Type	Cable Length	Remarks
1	RF In	1	RF In/out	Un-Shielded	0.10m	NA
2	RF In/out	1	Spectrum Analyzer	Un-Shielded	None	NA
3	RF In/Out	1	BT Tester	Un-Shielded	0.5m	NA

I/O CABLES (RADIATED SETUP)

I/O CABLE LIST						
Cable No.	Port	# of Identical Ports	Connector Type	Cable Type	Cable Length	Remarks
1	AC	1	US115AC	Unshielded	1m	N/A
2	DC	1	DC	Unshielded	1m	NA
3	Audio	1	Mini-Jack	Unshielded	1.2 m	NA

TEST SETUP

The EUT is a standalone device.

SETUP DIAGRAM FOR TESTS (CONDUCTED TEST SETUP)

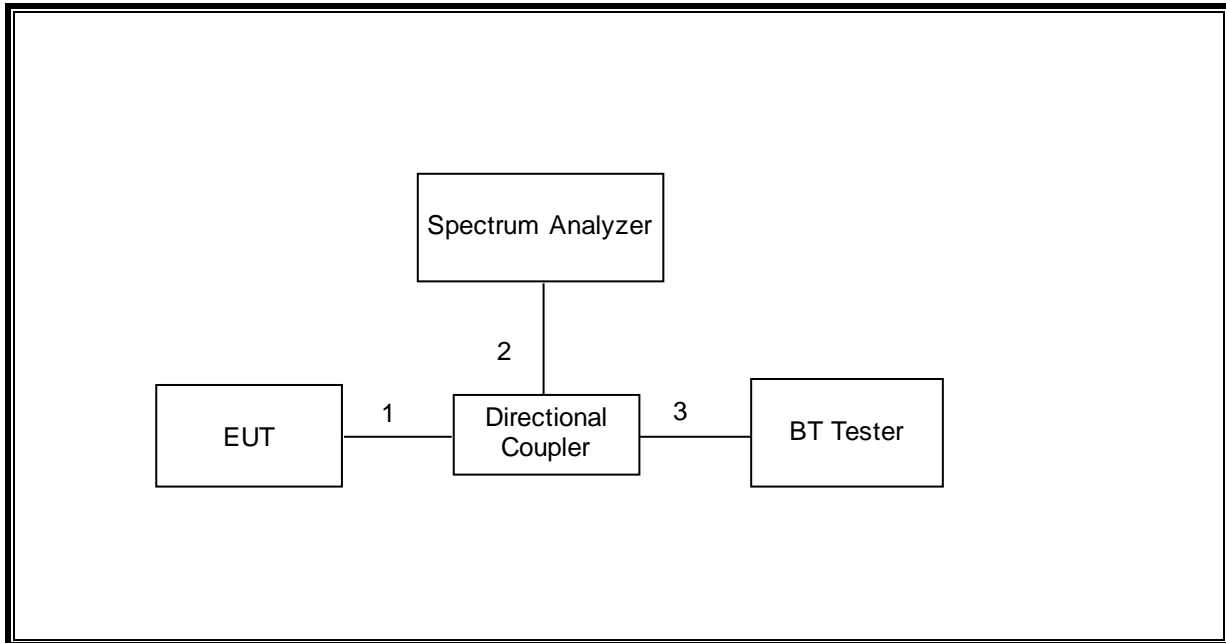

SETUP DIAGRAM FOR TESTS (RADIATED TEST SETUP)

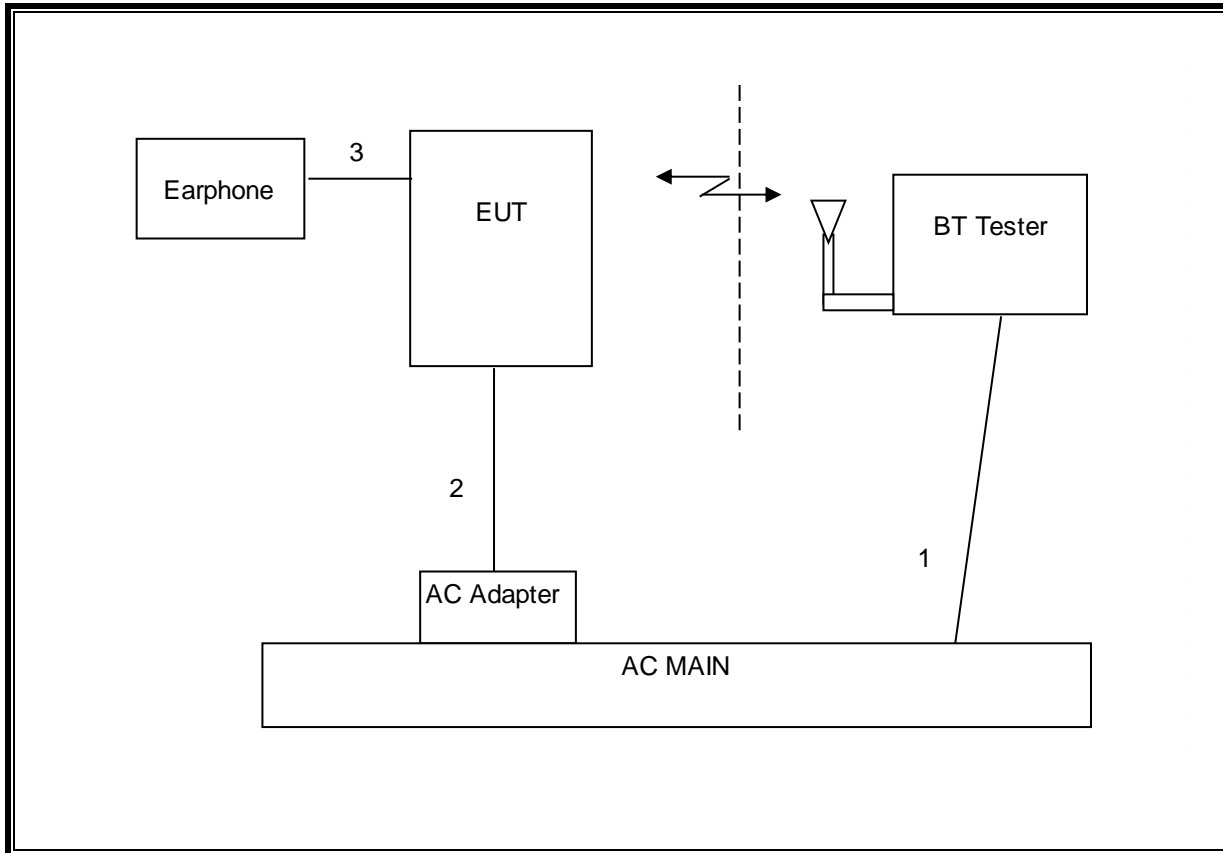

6. TEST AND MEASUREMENT EQUIPMENT

The following test and measurement equipment was utilized for the tests documented in this report:

TEST EQUIPMENT LIST				
Description	Manufacturer	Model	Asset	Cal Due
Antenna, Bilog, 2 GHz	Sunol Sciences	JB1	C01016	07/16/12
Antenna, Horn, 18 GHz	EMCO	3115	C00783	06/29/12
Preamplifier, 26.5 GHz	Agilent / HP	8449B	C01063	07/12/12
Preamplifier, 1300 MHz	Agilent / HP	8447D	C00580	11/11/12
Spectrum Analyzer, 26.5 GHz	Agilent / HP	E4440A	C01179	02/16/13
Antenna, Horn, 18 GHz	EMCO	3115	C00945	10/06/12
Spectrum Analyzer, 44 GHz	Agilent / HP	E4446A	C01159	04/09/13
Power Meter	Agilent / HP	437B	None	07/28/12
BT Tester	R & S	CBT	None	05/13/13
Power Sensor, 18 GHz	Agilent / HP	8481A	N02782	07/29/13
Spectrum Analyzer, 44 GHz	Agilent / HP	E4446A	C00986	03/22/13
Preamplifier, 26.5 GHz	Agilent / HP	8449B	C01052	07/12/12
Antenna, Horn, 26.5 GHz	ARA	MWH-1826/B	C00980	07/28/12
EMI Test Receiver, 9 kHz-7 GHz	R & S	ESCI 7	1000741	07/06/12
LISN, 30 MHz	FCC	50/250-25-2	C00626	12/13/12

7. ANTENNA PORT TEST RESULTS

7.1. BASIC DATA RATE GFSK MODULATION

7.1.1. 20 dB BANDWIDTH

LIMIT

None; for reporting purposes only.

TEST PROCEDURE

The transmitter output is connected to a spectrum analyzer. The RBW is set to $\geq 1\%$ of the 20 dB bandwidth. The VBW is set to \geq RBW. The sweep time is coupled.

RESULTS

Channel	Frequency (MHz)	20 dB Bandwidth (MHz)
Low	2402	1.045
Middle	2441	1.045
High	2480	1.045

20 dB BANDWIDTH

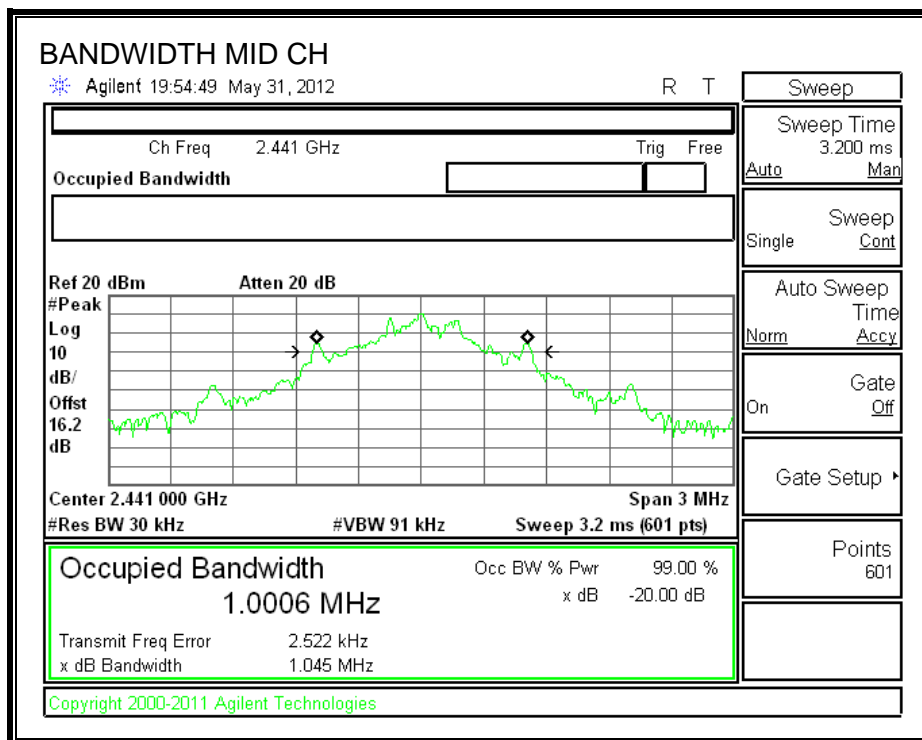
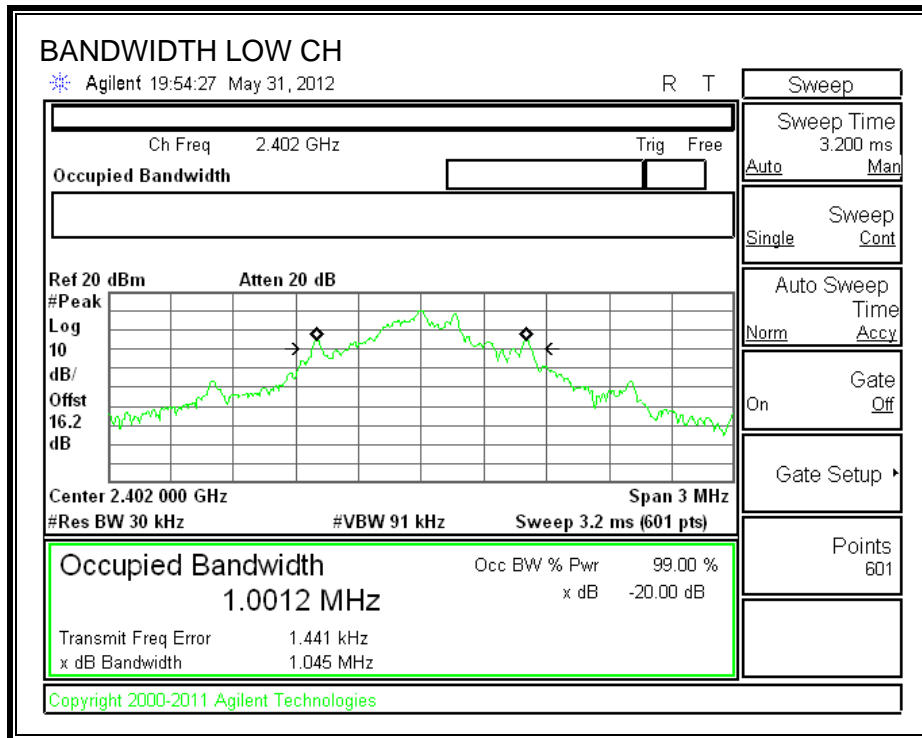

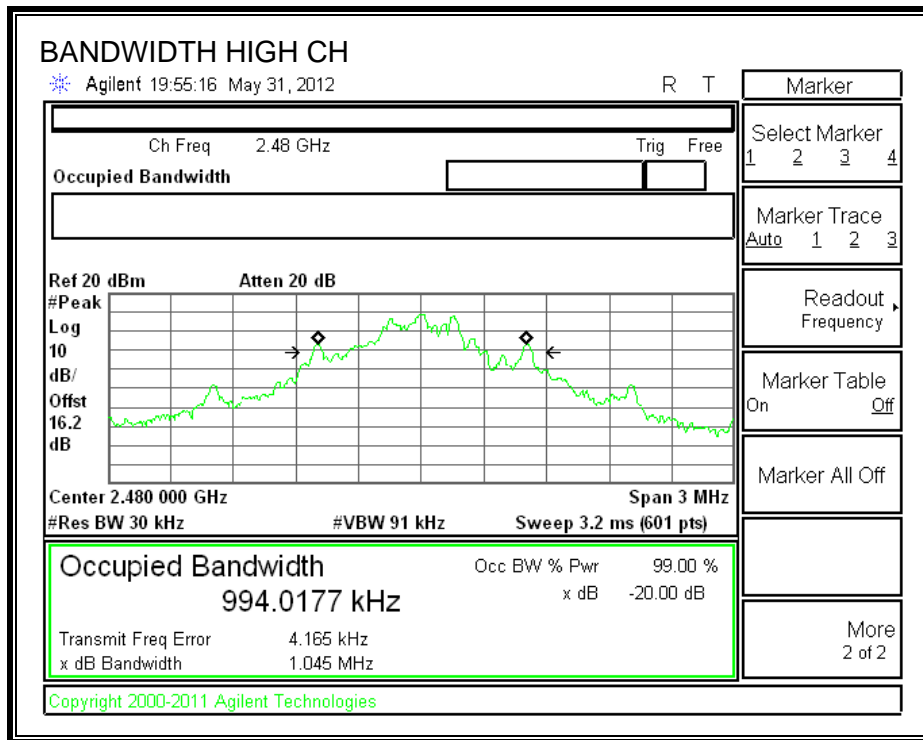

7.1.2. HOPPING FREQUENCY SEPARATION

LIMIT

FCC §15.247 (a) (1)

Frequency hopping systems shall have hopping channel carrier frequencies separated by a minimum of 25 kHz or the 20 dB bandwidth of the hopping channel, whichever is greater.

Alternatively, frequency hopping systems operating in the 2400-2483.5 MHz band may have hopping channel carrier frequencies that are separated by 25 kHz or two-thirds of the 20 dB bandwidth of the hopping channel, whichever is greater, provided the systems operate with an output power no greater than 125 mW.

TEST PROCEDURE

The transmitter output is connected to a spectrum analyzer. The RBW is set to 100 kHz and the VBW is set to 100 kHz. The sweep time is coupled.

RESULTS

HOPPING FREQUENCY SEPARATION

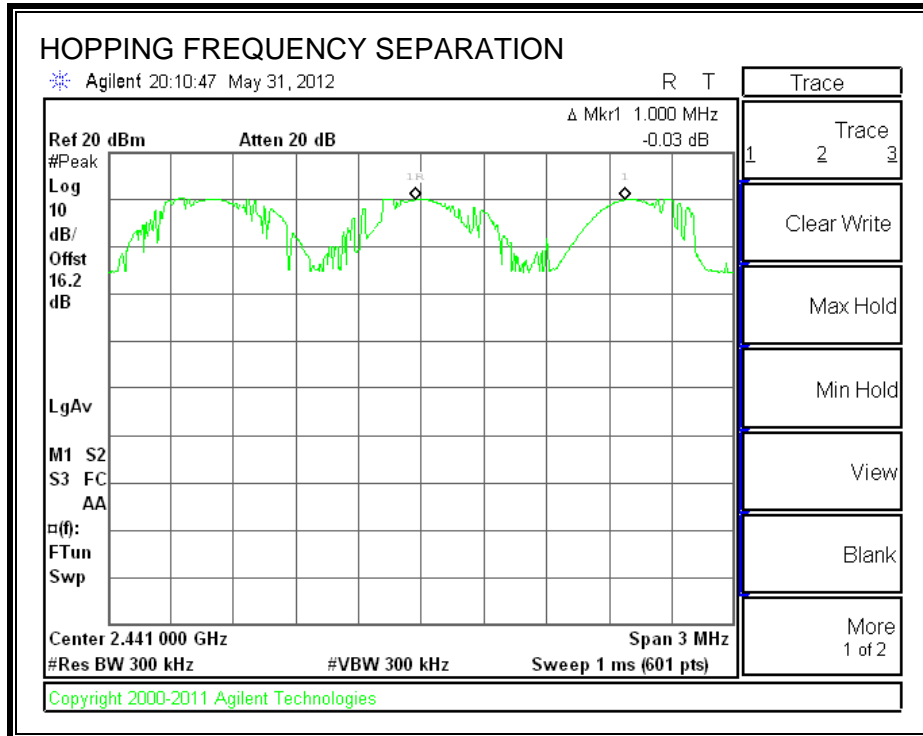

7.1.3. NUMBER OF HOPPING CHANNELS

LIMIT

FCC §15.247 (a) (1) (iii)

Frequency hopping systems in the 2400 – 2483.5 MHz band shall use at least 15 non-overlapping channels.

TEST PROCEDURE

The transmitter output is connected to a spectrum analyzer. The span is set to cover the entire authorized band, in either a single sweep or in multiple contiguous sweeps. The RBW is set to a maximum of 1 % of the span. The analyzer is set to Max Hold.

RESULTS

Normal mode: 79 Channels observed.

AFH mode: 20 channels as declared by the manufacturer.

NUMBER OF HOPPING CHANNELS (NORMAL MODE)

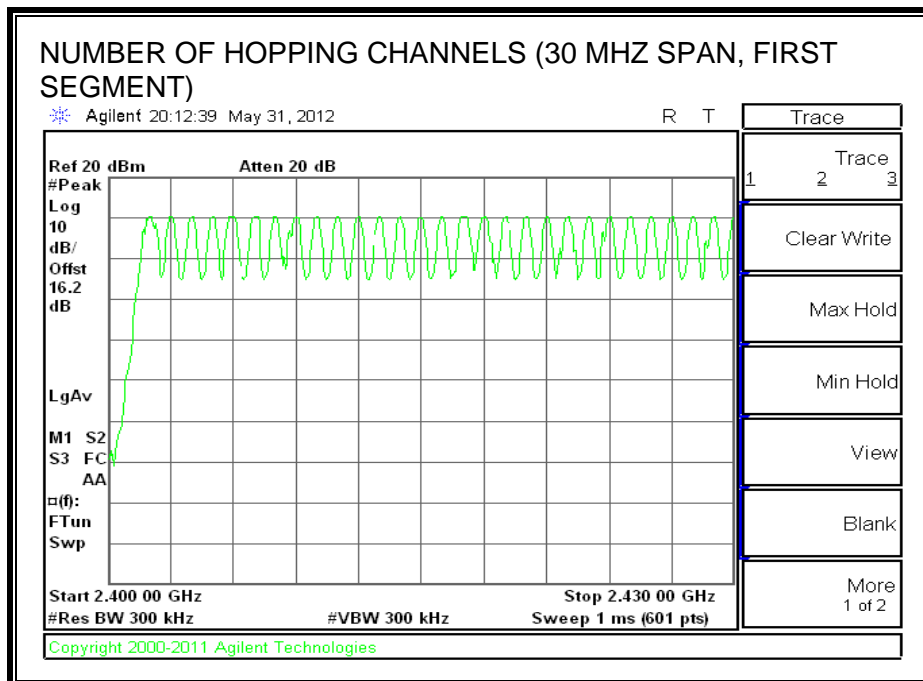
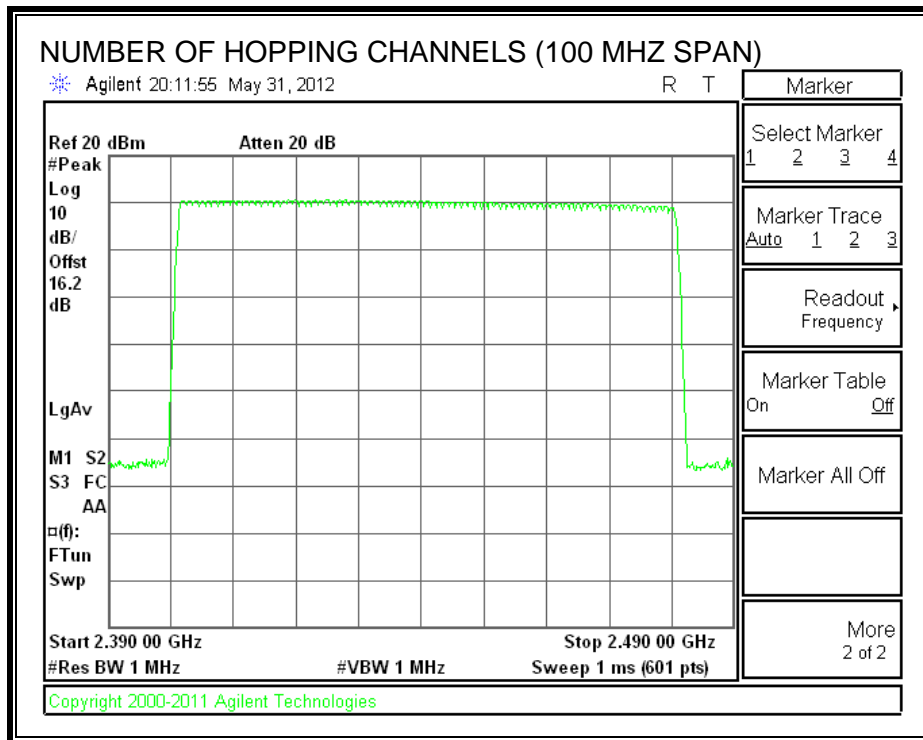

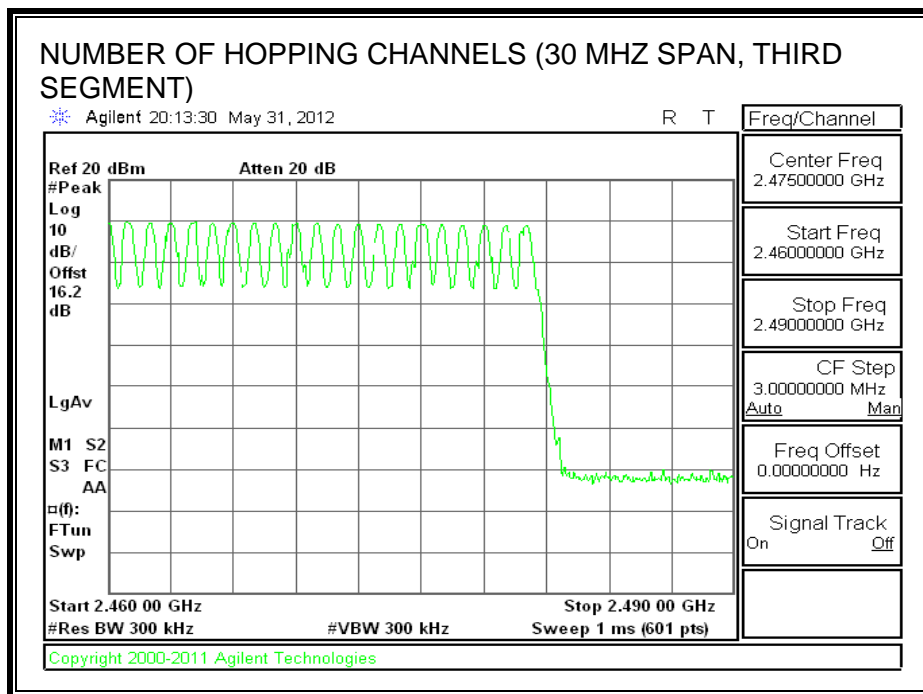
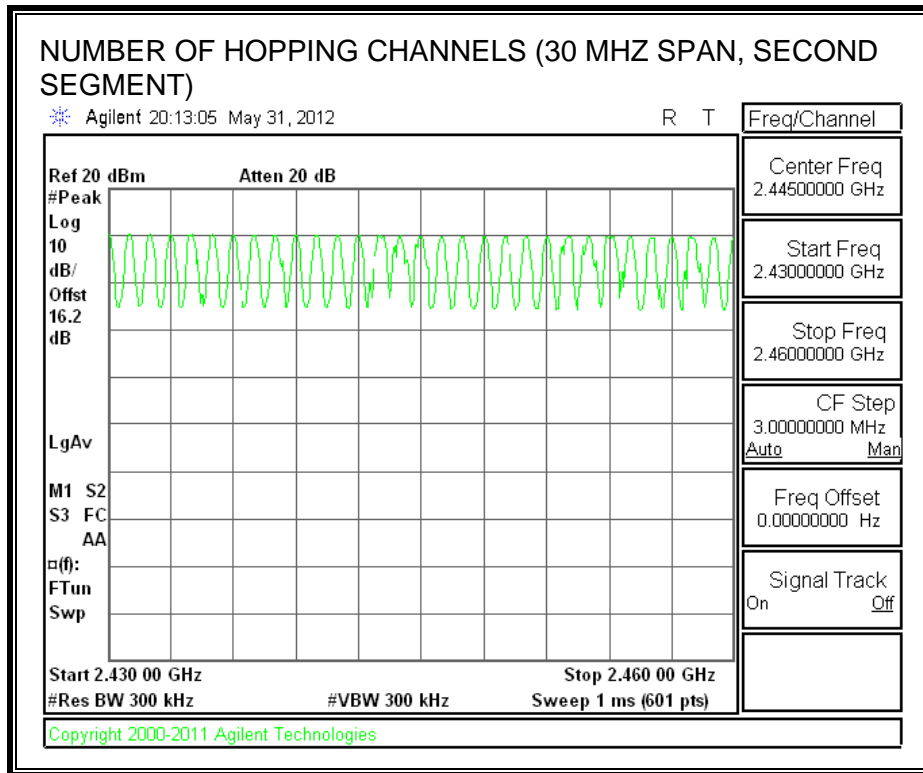

7.1.4. AVERAGE TIME OF OCCUPANCY

LIMIT

FCC §15.247 (a) (1) (iii)

The average time of occupancy on any channel shall not be greater than 0.4 seconds within a period of 0.4 seconds multiplied by the number of hopping channels employed.

TEST PROCEDURE

The transmitter output is connected to a spectrum analyzer. The span is set to 0 Hz, centered on a single, selected hopping channel. The width of a single pulse is measured in a fast scan. The number of pulses is measured in a 3.16 second scan, to enable resolution of each occurrence.

The average time of occupancy in the specified 31.6 second period (79 channels * 0.4 s) is equal to $10 * (\# \text{ of pulses in } 3.16 \text{ s}) * \text{ pulse width}$.

RESULTS

DH Packet	Pulse Width (msec)	Number of Pulses in 3.16 seconds	Average Time of Occupan cy (sec)	Limit (sec)	Margin (sec)
DH1	0.408	33	0.135	0.4	-0.265
DH3	1.675	12	0.201	0.4	-0.199
DH5	2.908	6	0.174	0.4	-0.226

NORMAL MODE

PULSE WIDTH - DH1

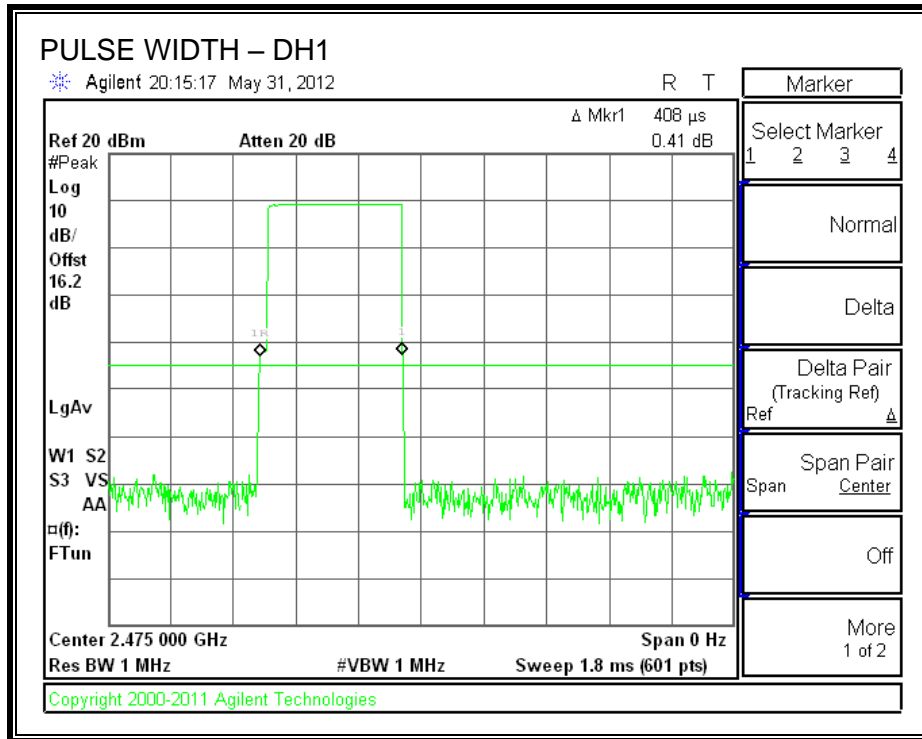

NUMBER OF PULSES IN 3.16 SECOND OBSERVATION PERIOD - DH1

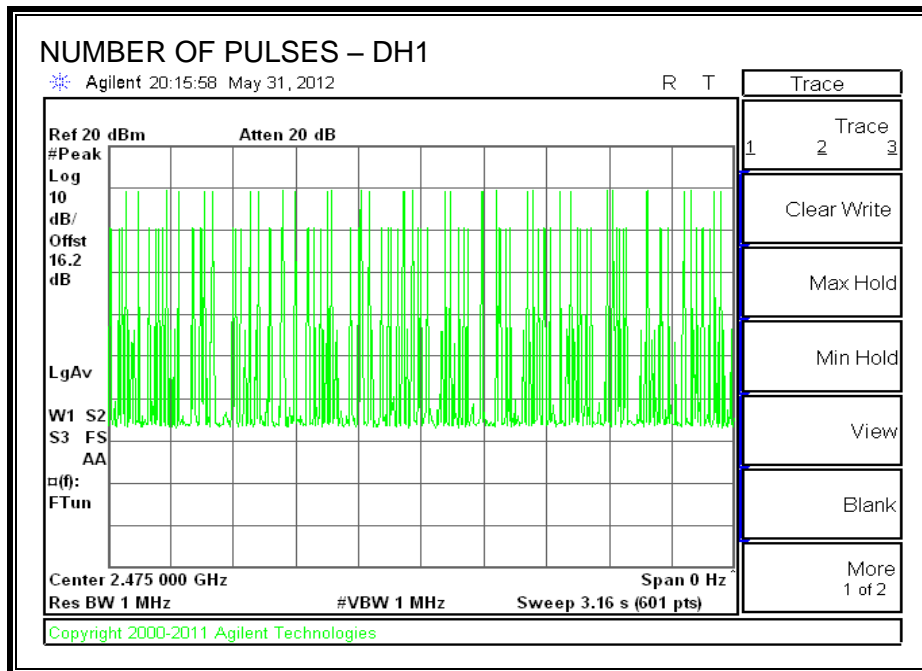

PULSE WIDTH – DH3

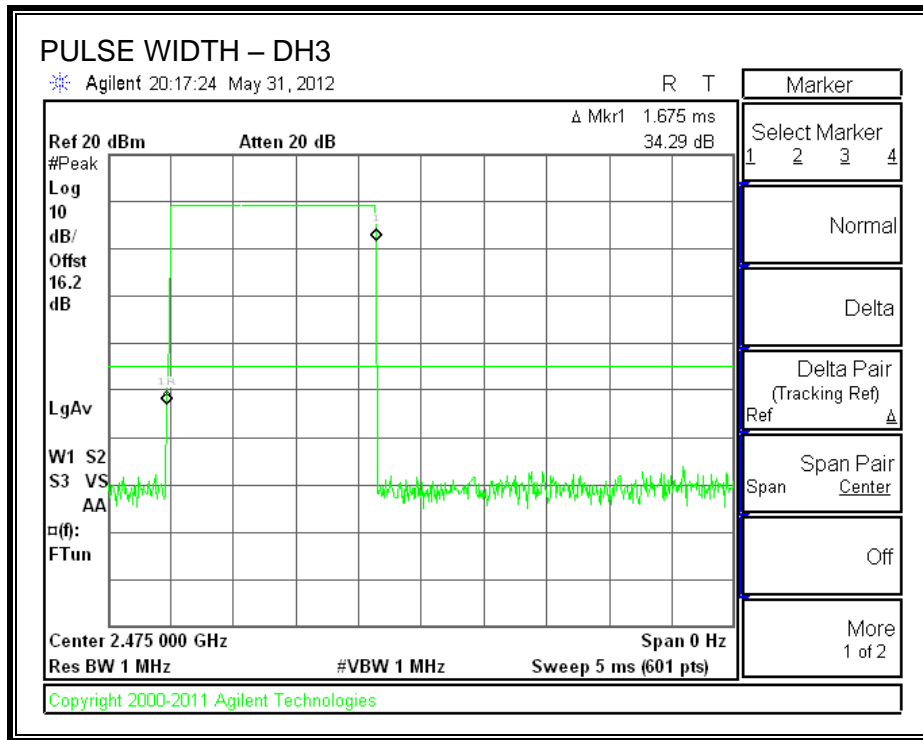

NUMBER OF PULSES IN 3.16 SECOND OBSERVATION PERIOD – DH3

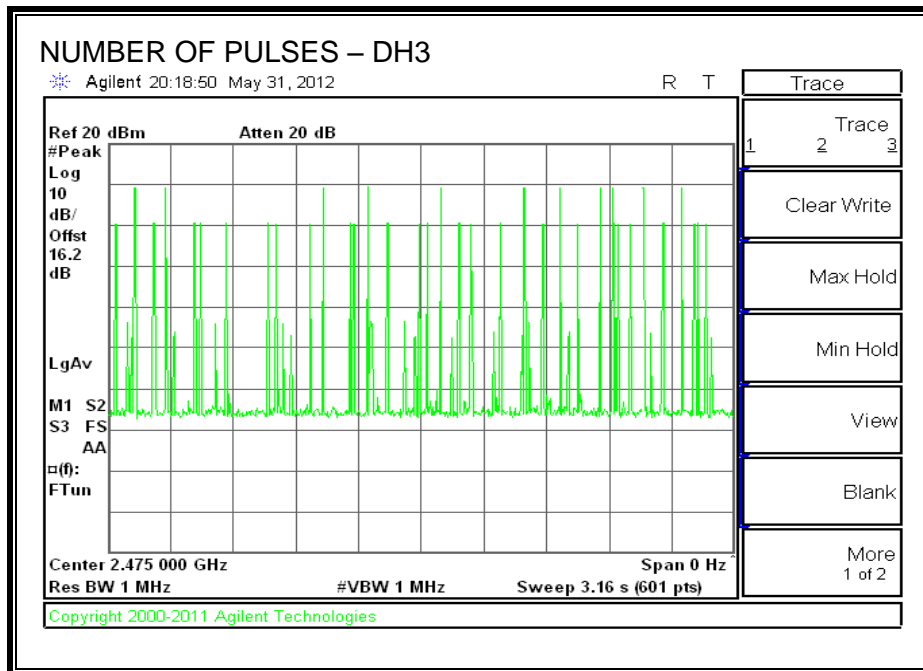

PULSE WIDTH – DH5

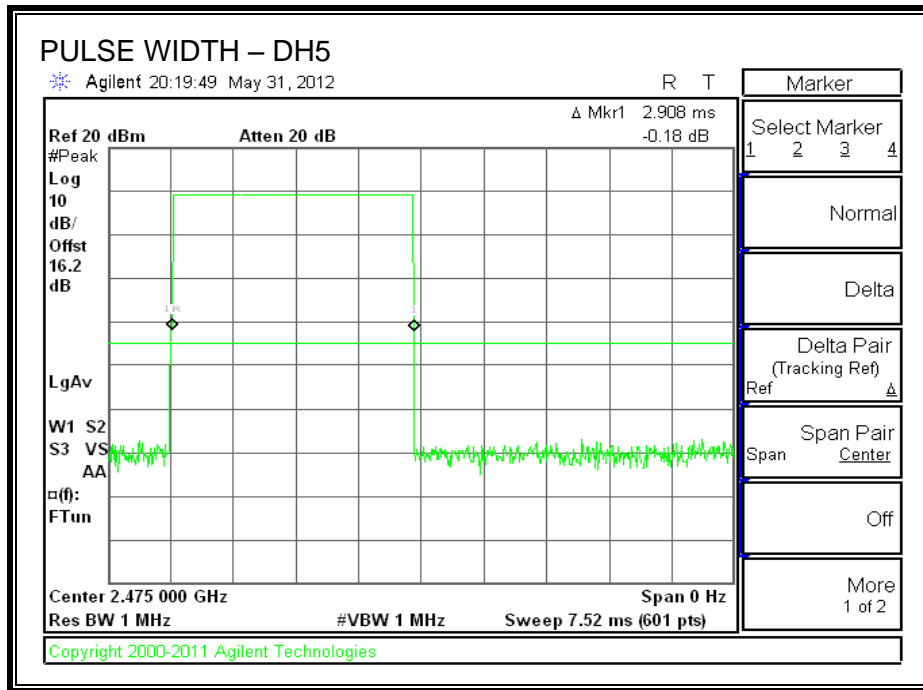

NUMBER OF PULSES IN 3.16 SECOND OBSERVATION PERIOD – DH5

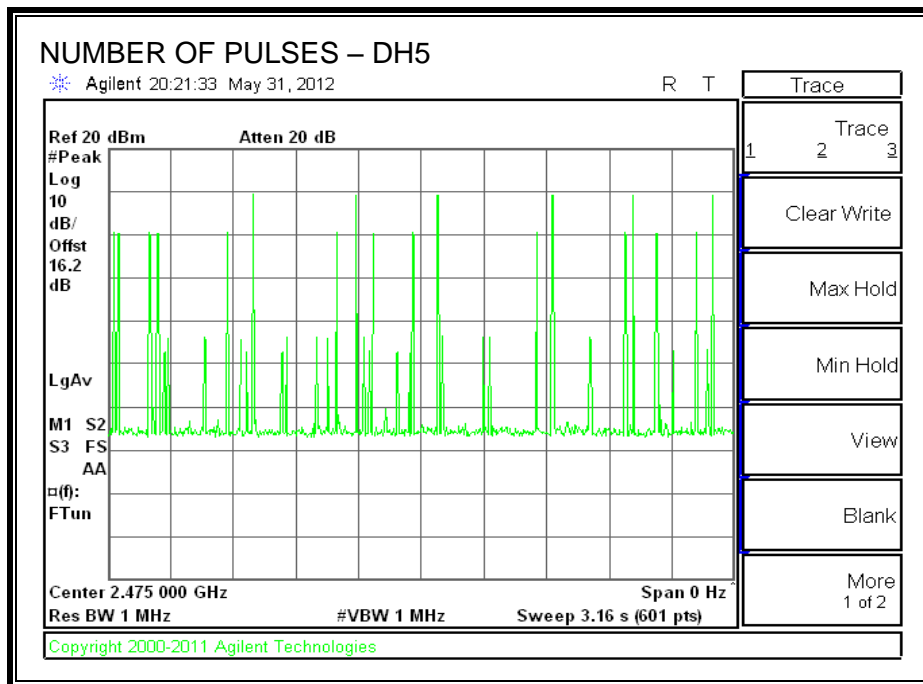

7.1.5. OUTPUT POWER

LIMIT

§15.247 (b) (1)

The maximum antenna gain is less than 6 dBi, therefore the limit is 30 dBm.

TEST PROCEDURE

The transmitter output is connected to a spectrum analyzer the analyzer bandwidth is set to a value greater than the 20 dB bandwidth of the EUT.

RESULTS

Channel	Frequency (MHz)	Output Power (dBm)	Limit (dBm)	Margin (dB)
Low	2402	10.57	30.00	-19.43
Middle	2441	10.30	30.00	-19.70
High	2480	9.10	30.00	-20.90

OUTPUT POWER

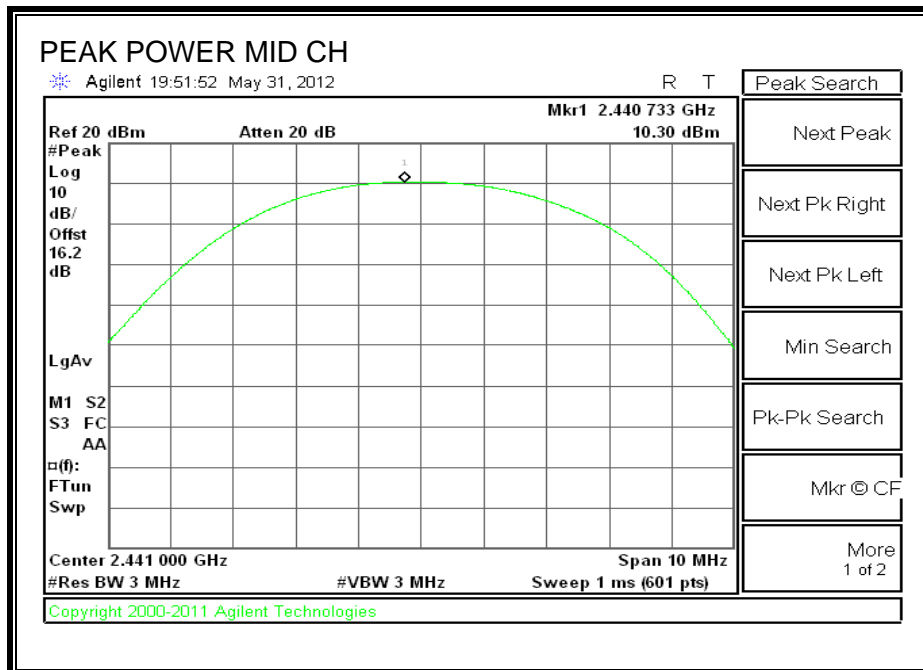
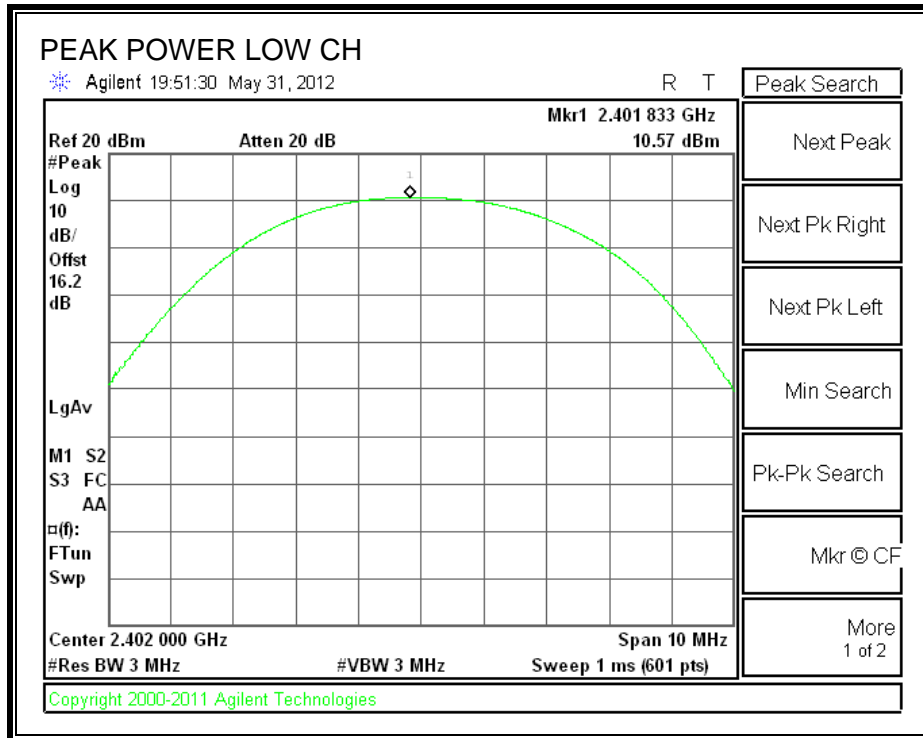

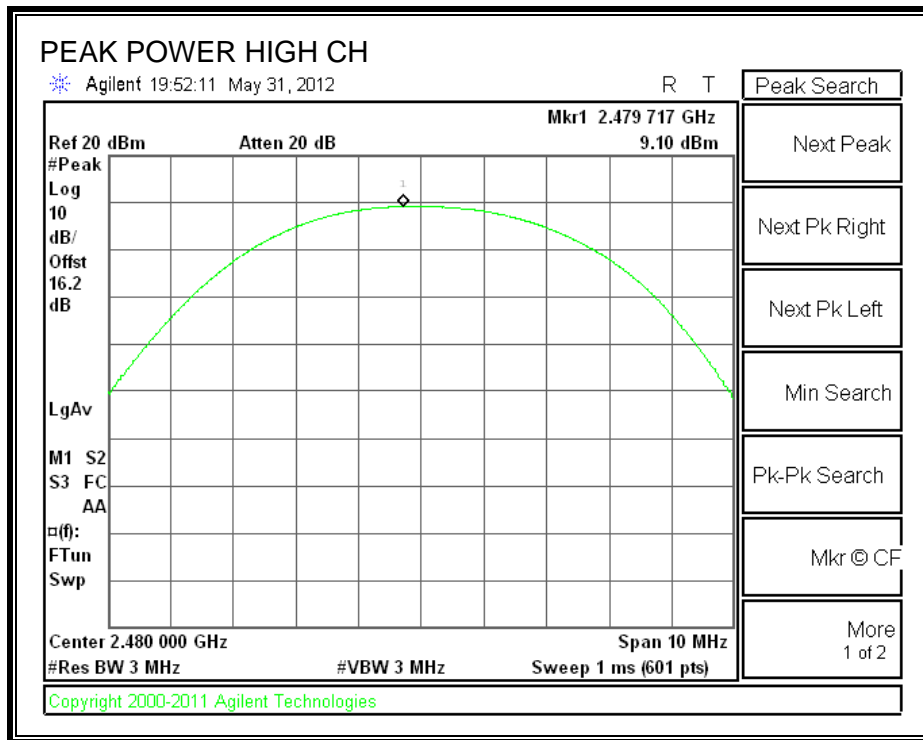

7.1.6. AVERAGE POWER

LIMIT

None; for reporting purposes only.

TEST PROCEDURE

The transmitter output is connected to a power meter.

RESULTS

The cable assembly insertion loss of 11.2 dB (including 10 dB pad and 1.2 dB cable) was entered as an offset in the power meter to allow for direct reading of power.

Channel	Frequency (MHz)	Average Power (dBm)
Low	2402	10.00
Middle	2441	9.70
High	2480	8.50

7.1.7. CONDUCTED SPURIOUS EMISSIONS

LIMITS

FCC §15.247 (d)

Limit = -20 dBc

TEST PROCEDURE

The transmitter output is connected to a spectrum analyzer. The resolution bandwidth is set to 100 kHz. The video bandwidth is set to 300 kHz.

The spectrum from 30 MHz to 26 GHz is investigated with the transmitter set to the lowest, middle, and highest channels.

The bandedges at 2.4 and 2.4835 GHz are investigated with the transmitter set to the normal hopping mode.

RESULTS

SPURIOUS EMISSIONS, LOW CHANNEL

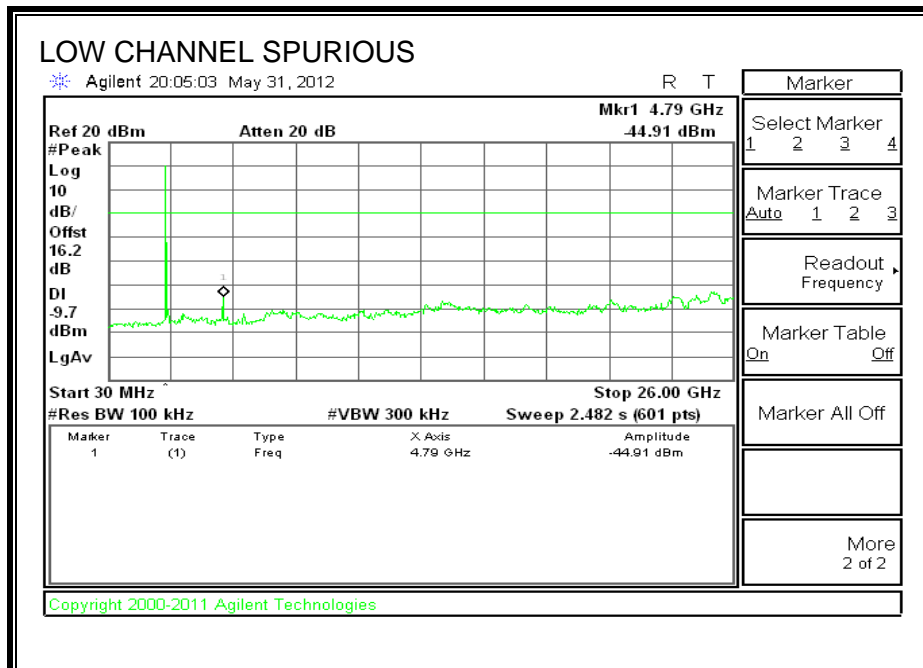
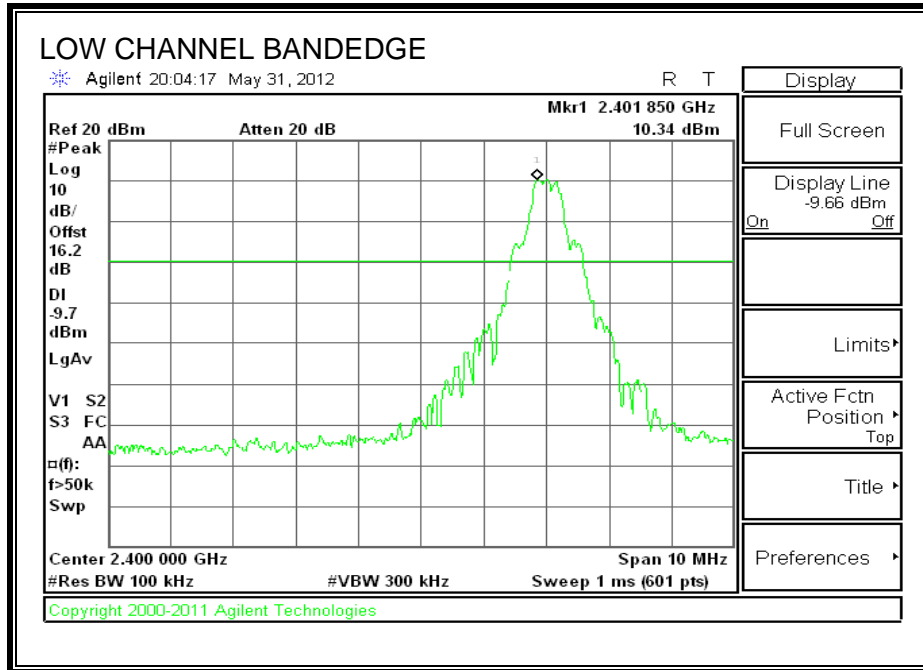

SPURIOUS EMISSIONS, MID CHANNEL

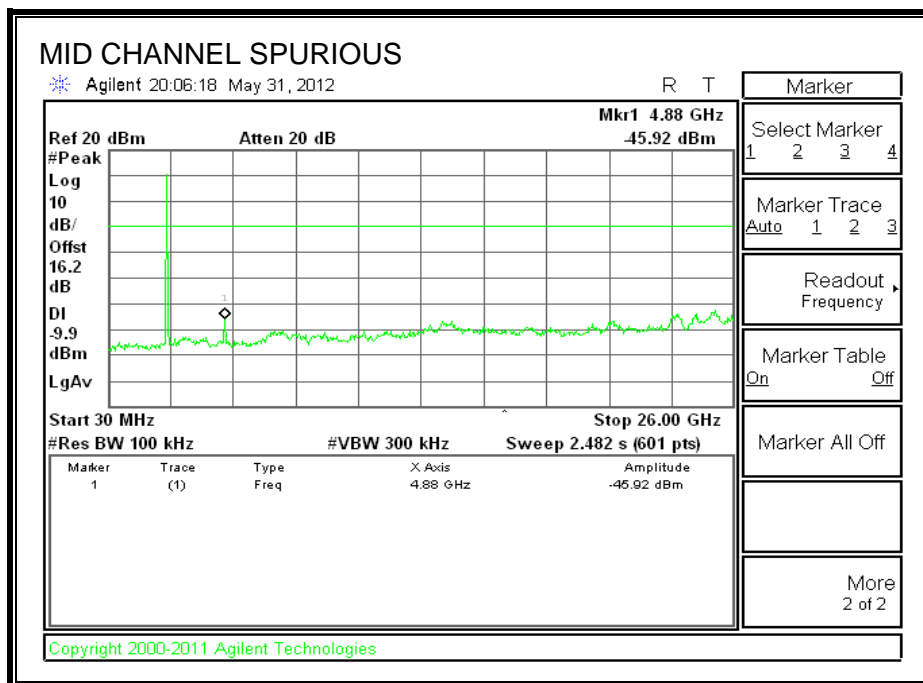
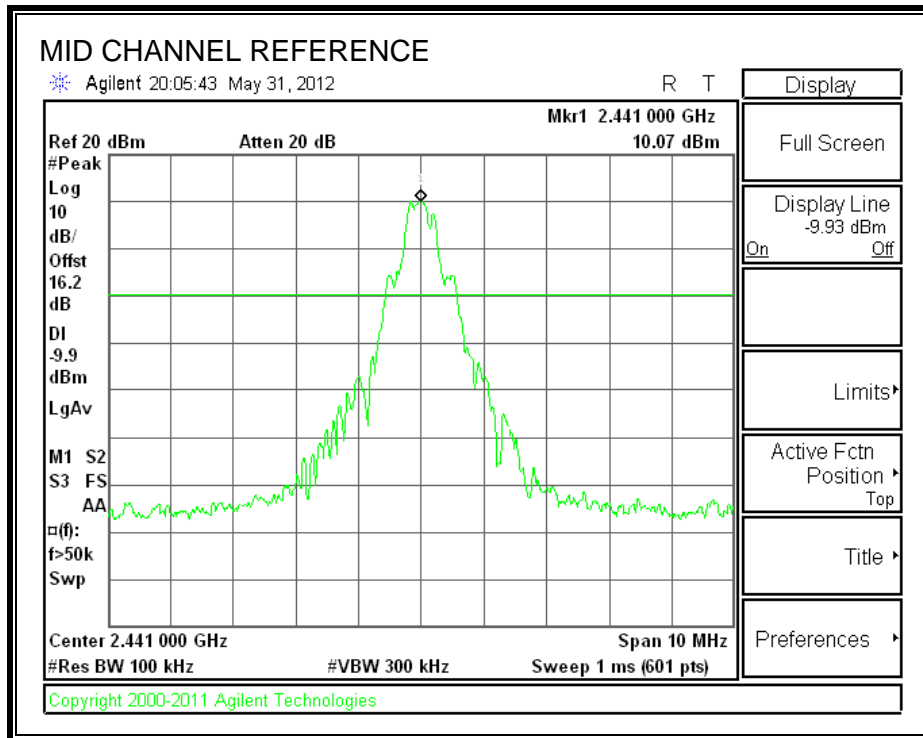

SPURIOUS EMISSIONS, HIGH CHANNEL

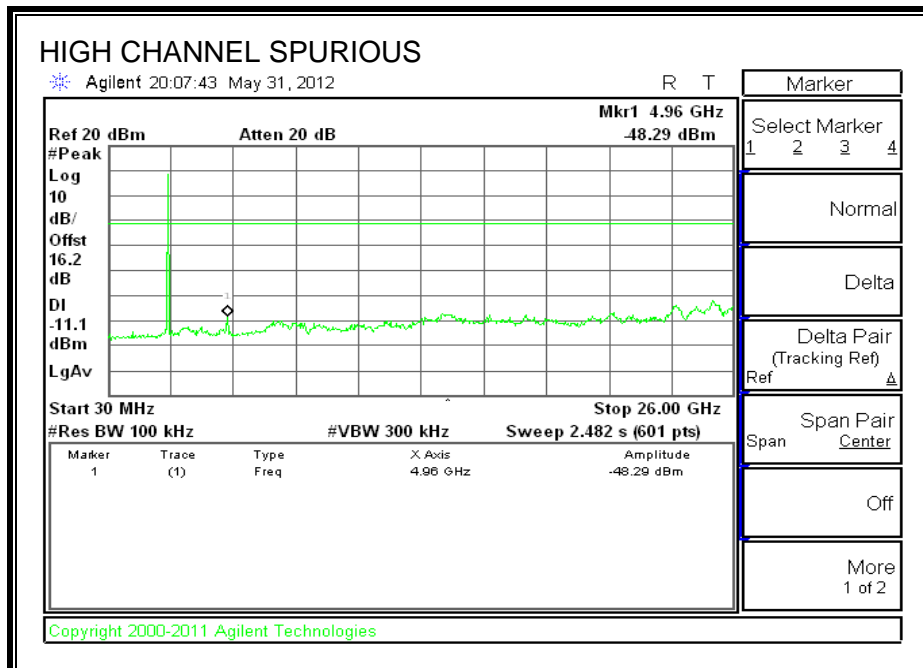
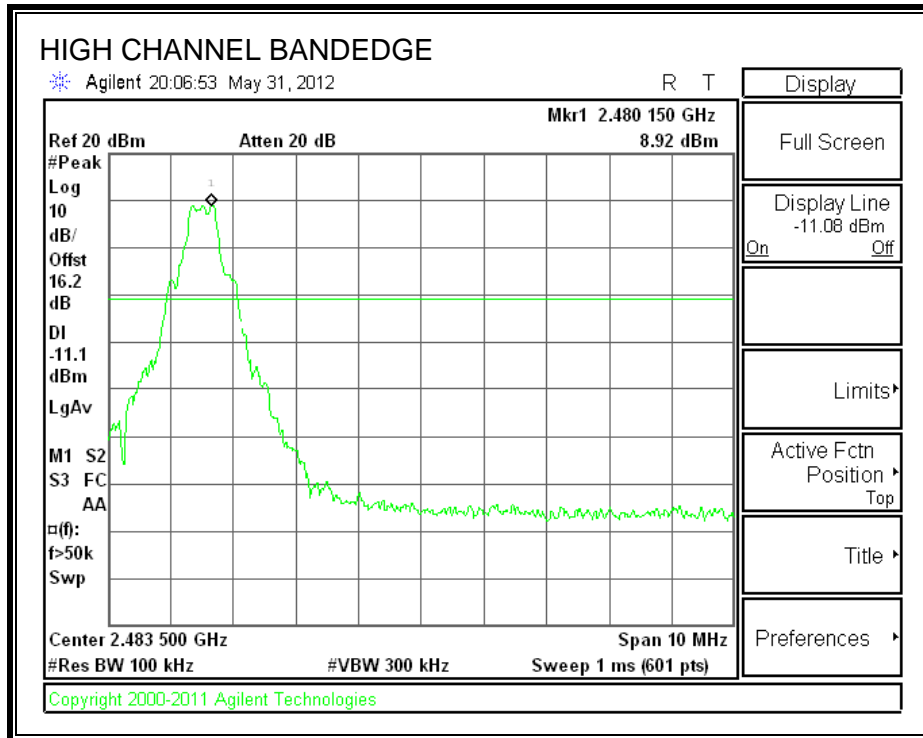

SPURIOUS BANDEDGE EMISSIONS WITH HOPPING ON

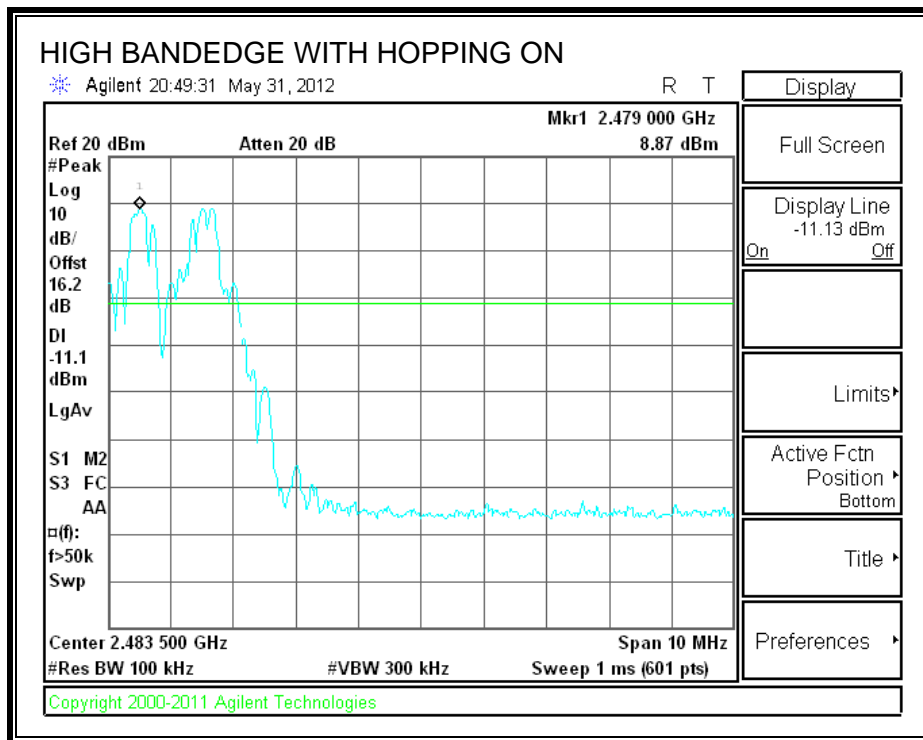
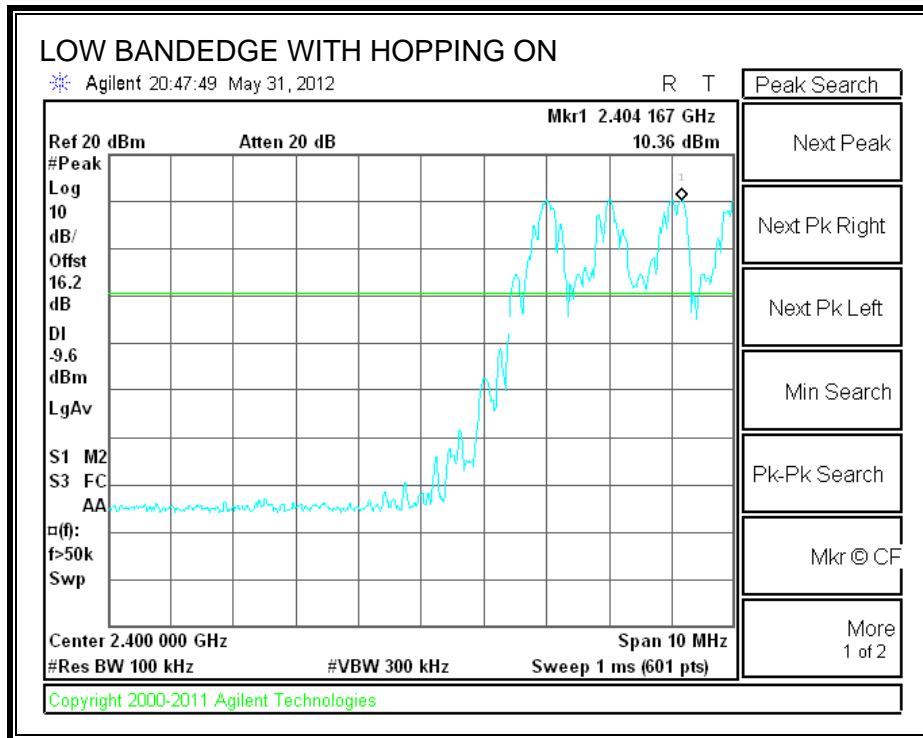

7.2. ENHANCED DATA RATE 8PSK MODULATION

7.2.1. 20 dB BANDWIDTH

LIMIT

None; for reporting purposes only.

TEST PROCEDURE

The transmitter output is connected to a spectrum analyzer. The RBW is set to $\geq 1\%$ of the 20 dB bandwidth. The VBW is set to \geq RBW. The sweep time is coupled.

RESULTS

Channel	Frequency (MHz)	20 dB Bandwidth (MHz)
Low	2402	1.203
Middle	2441	1.199
High	2480	1.204

20 dB BANDWIDTH

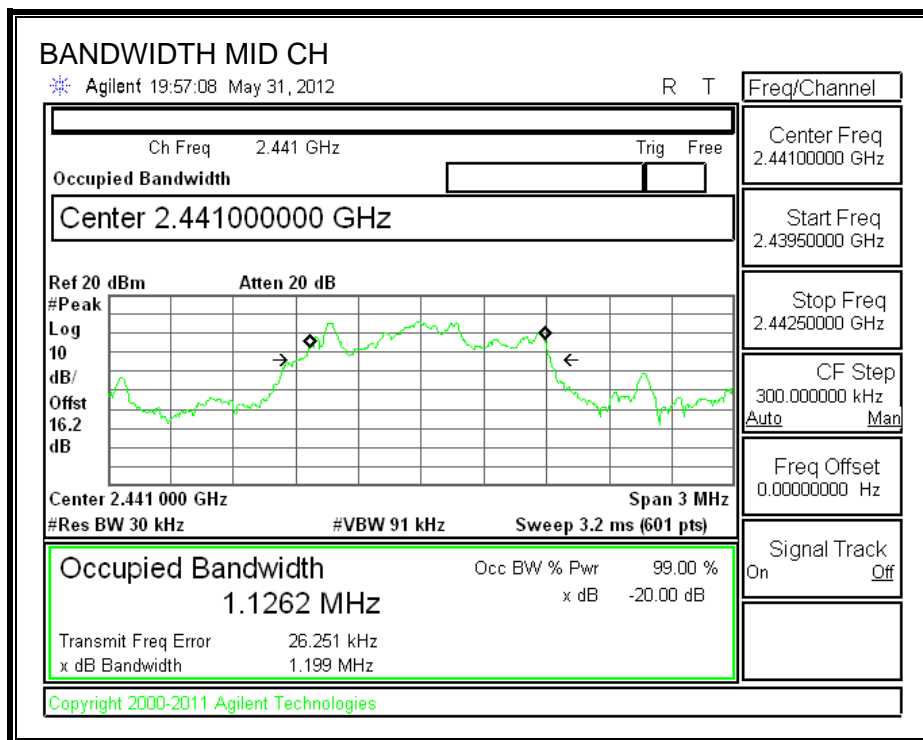
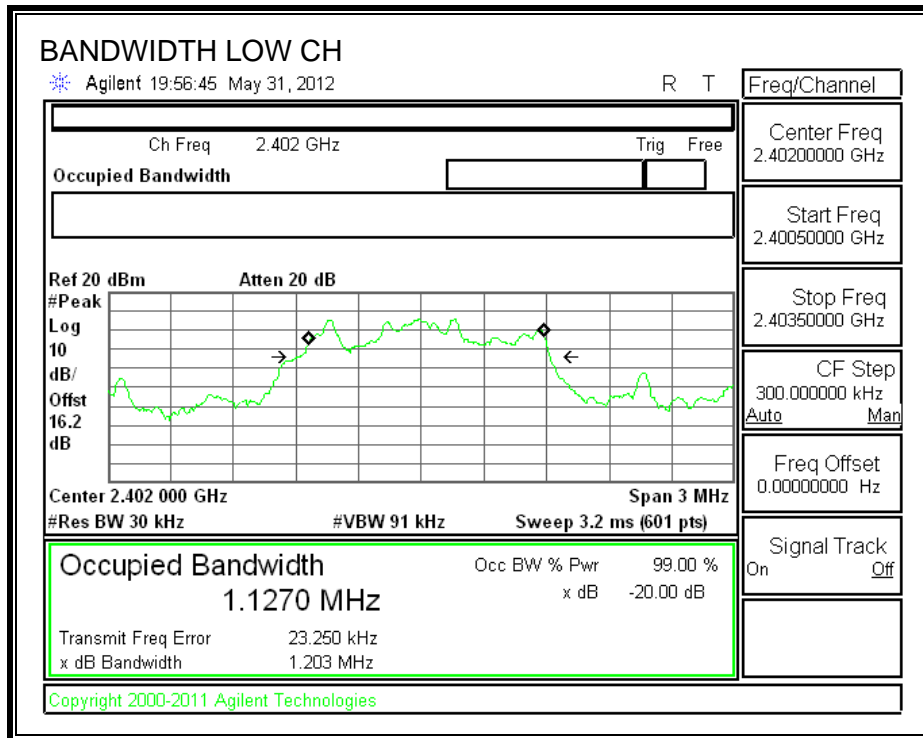

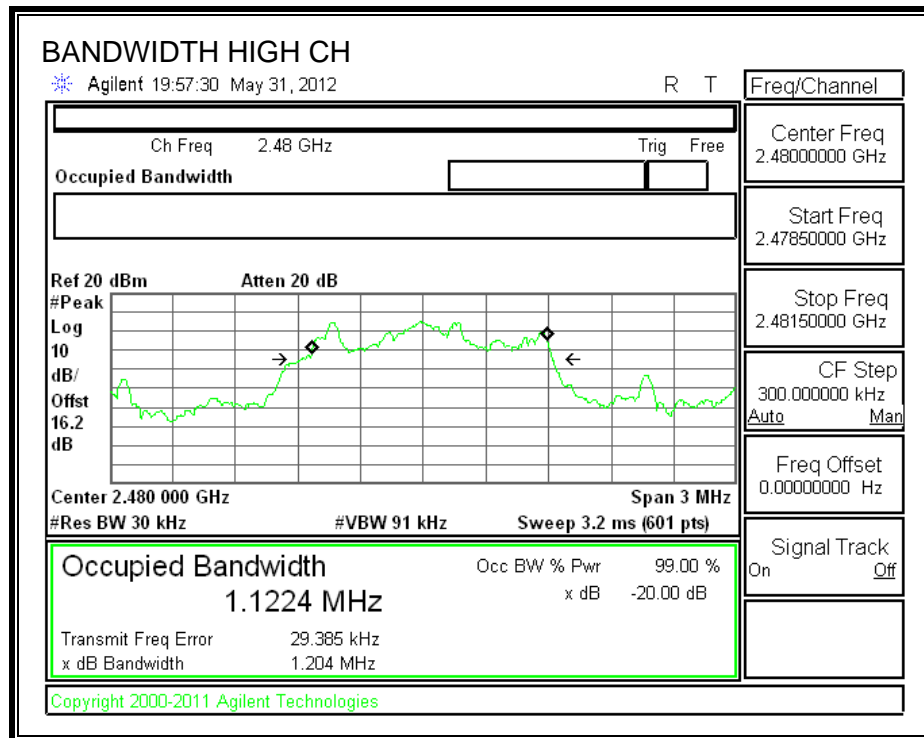

7.2.2. HOPPING FREQUENCY SEPARATION

LIMIT

FCC §15.247 (a) (1)

Frequency hopping systems shall have hopping channel carrier frequencies separated by a minimum of 25 kHz or the 20 dB bandwidth of the hopping channel, whichever is greater.

Alternatively, frequency hopping systems operating in the 2400-2483.5 MHz band may have hopping channel carrier frequencies that are separated by 25 kHz or two-thirds of the 20 dB bandwidth of the hopping channel, whichever is greater, provided the systems operate with an output power no greater than 125 mW.

TEST PROCEDURE

The transmitter output is connected to a spectrum analyzer. The RBW is set to 100 kHz and the VBW is set to 100 kHz. The sweep time is coupled.

RESULTS

HOPPING FREQUENCY SEPARATION

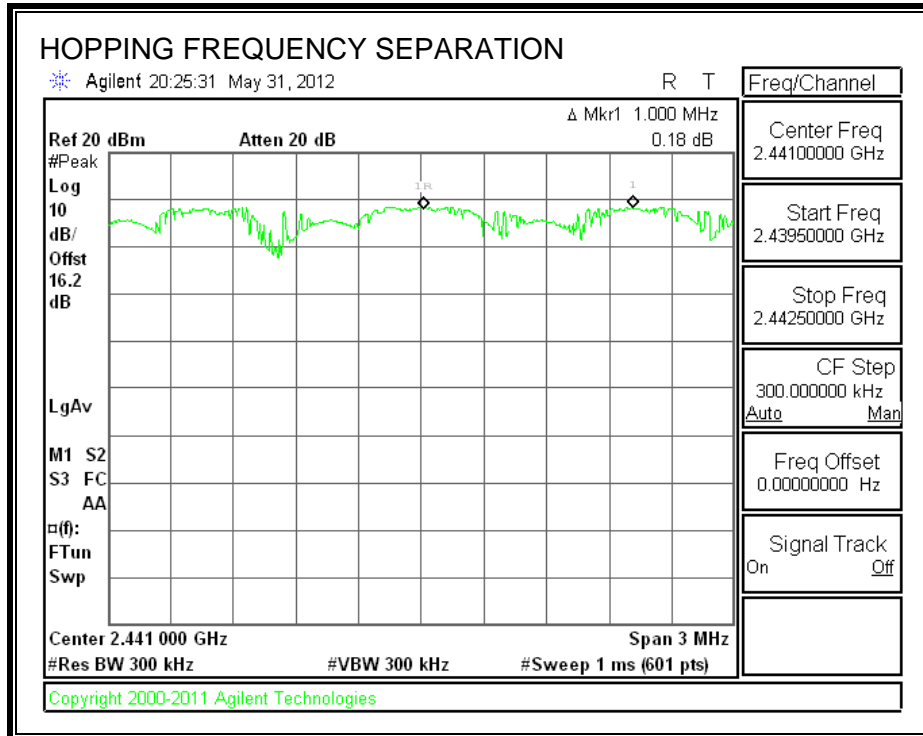

7.2.3. NUMBER OF HOPPING CHANNELS

LIMIT

FCC §15.247 (a) (1) (iii)

Frequency hopping systems in the 2400 – 2483.5 MHz band shall use at least 15 non-overlapping channels.

TEST PROCEDURE

The transmitter output is connected to a spectrum analyzer. The span is set to cover the entire authorized band, in either a single sweep or in multiple contiguous sweeps. The RBW is set to a maximum of 1 % of the span. The analyzer is set to Max Hold.

RESULTS

Normal mode: 79 Channels observed.

AFH mode: 20 channels as declared by the manufacturer.

NUMBER OF HOPPING CHANNELS (NORMAL MODE)

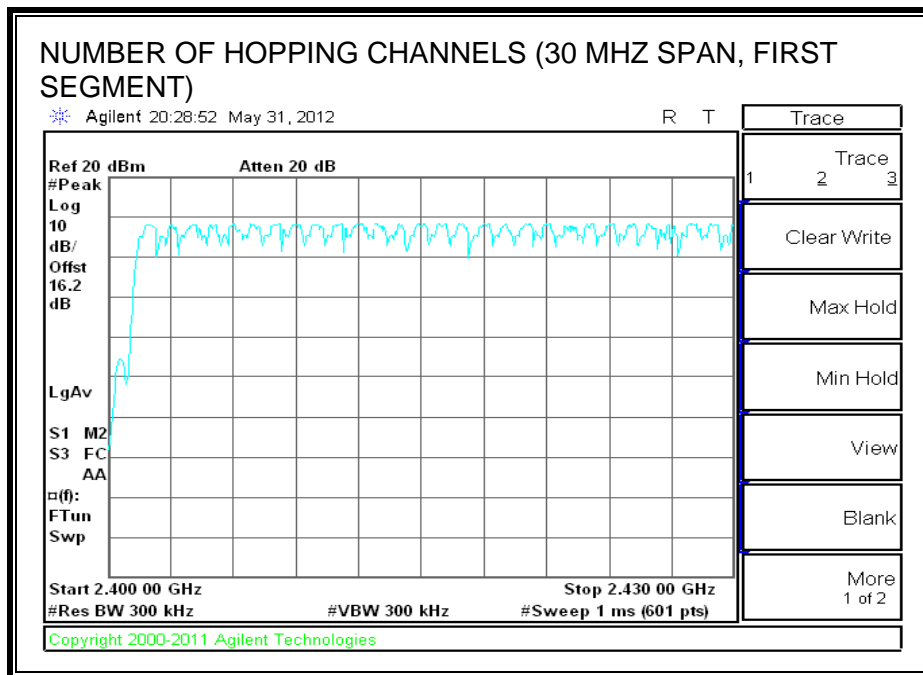
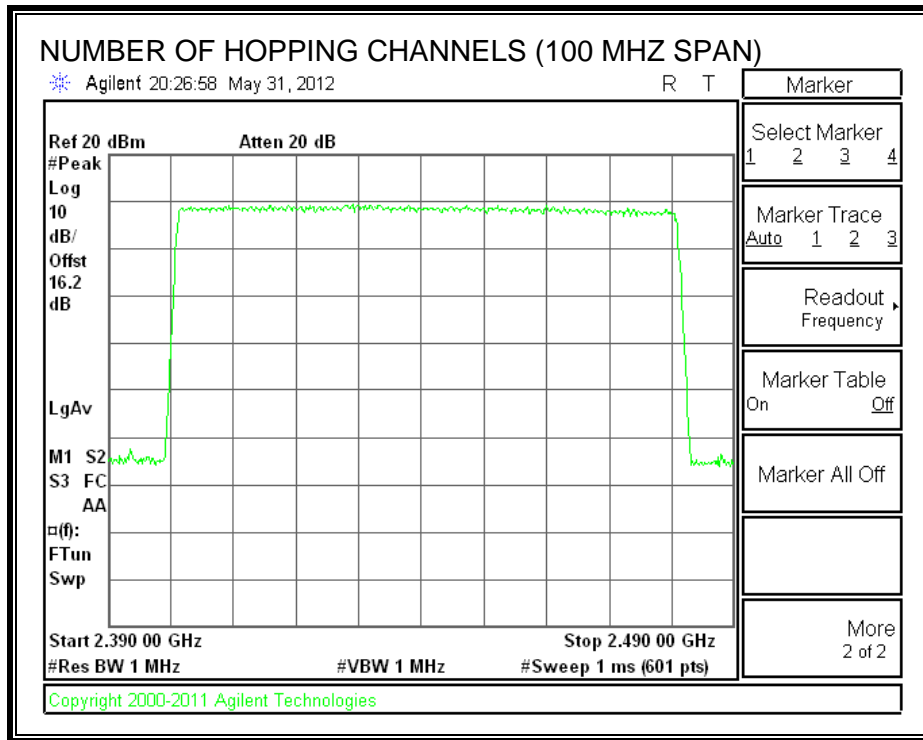

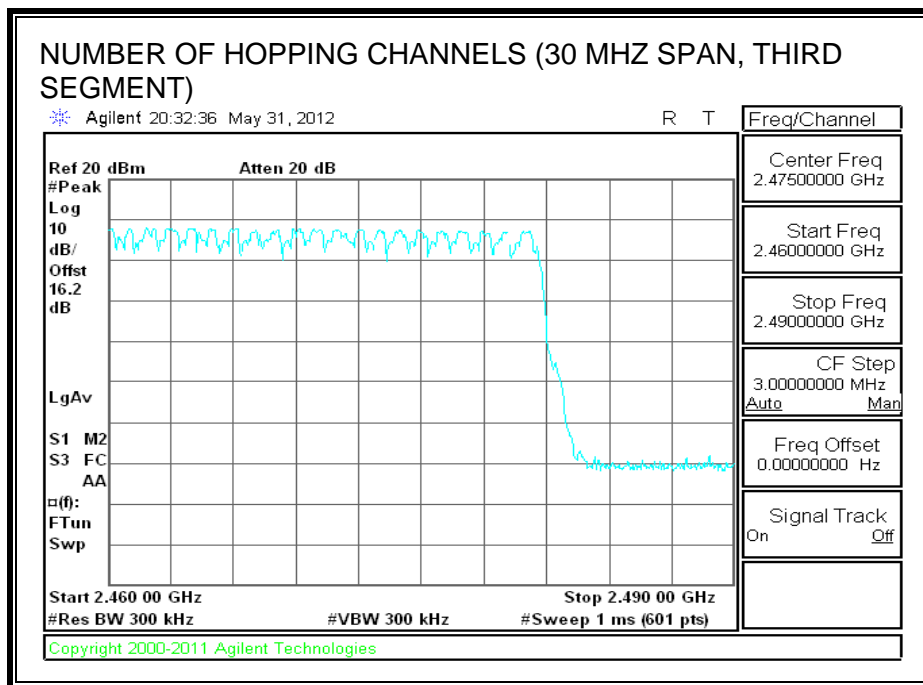
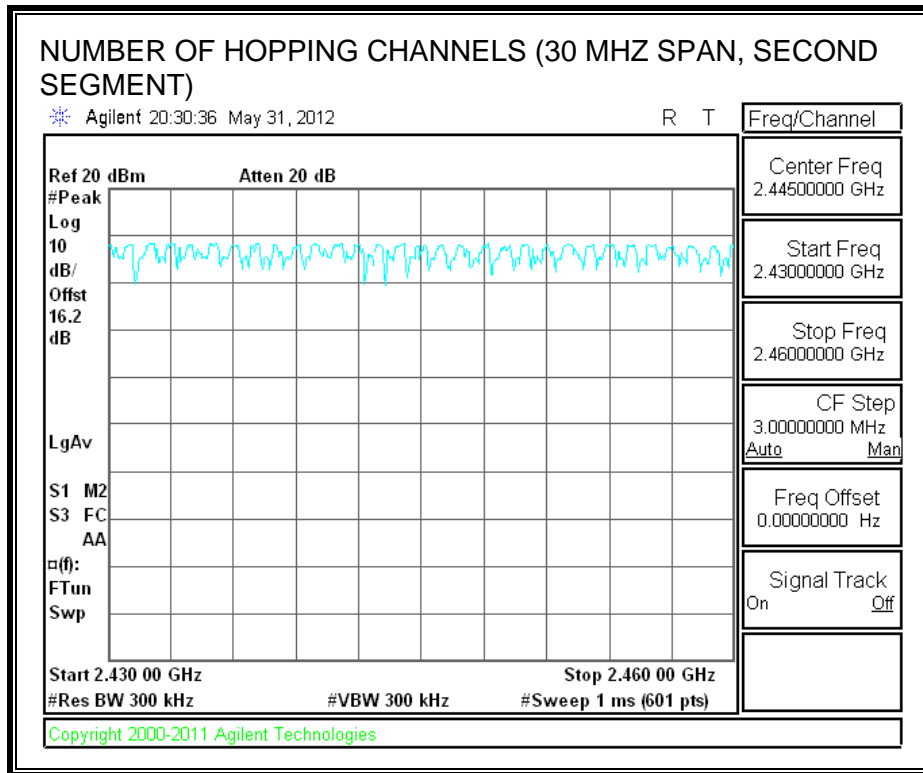

7.2.4. AVERAGE TIME OF OCCUPANCY

LIMIT

FCC §15.247 (a) (1) (iii)

The average time of occupancy on any channel shall not be greater than 0.4 seconds within a period of 0.4 seconds multiplied by the number of hopping channels employed.

TEST PROCEDURE

The transmitter output is connected to a spectrum analyzer. The span is set to 0 Hz, centered on a single, selected hopping channel. The width of a single pulse is measured in a fast scan. The number of pulses is measured in a 3.16 second scan, to enable resolution of each occurrence.

The average time of occupancy in the specified 31.6 second period (79 channels * 0.4 s) is equal to $10 * (\# \text{ of pulses in } 3.16 \text{ s}) * \text{ pulse width}$.

RESULTS

DH Packet	Pulse Width (msec)	Number of Pulses in 3.16 seconds	Average Time of Occupan cy (sec)	Limit (sec)	Margin (sec)
DH1	0.42	33	0.139	0.4	-0.261
DH3	1.658	16	0.265	0.4	-0.135
DH5	2.908	9	0.262	0.4	-0.138

NORMAL MODE

PULSE WIDTH - DH1

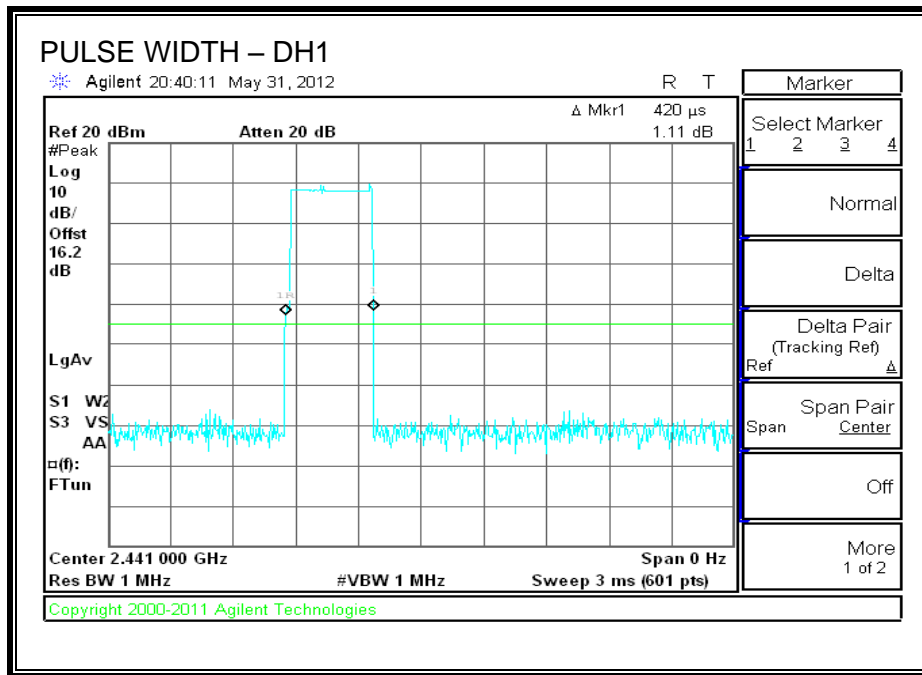

NUMBER OF PULSES IN 3.16 SECOND OBSERVATION PERIOD - DH1

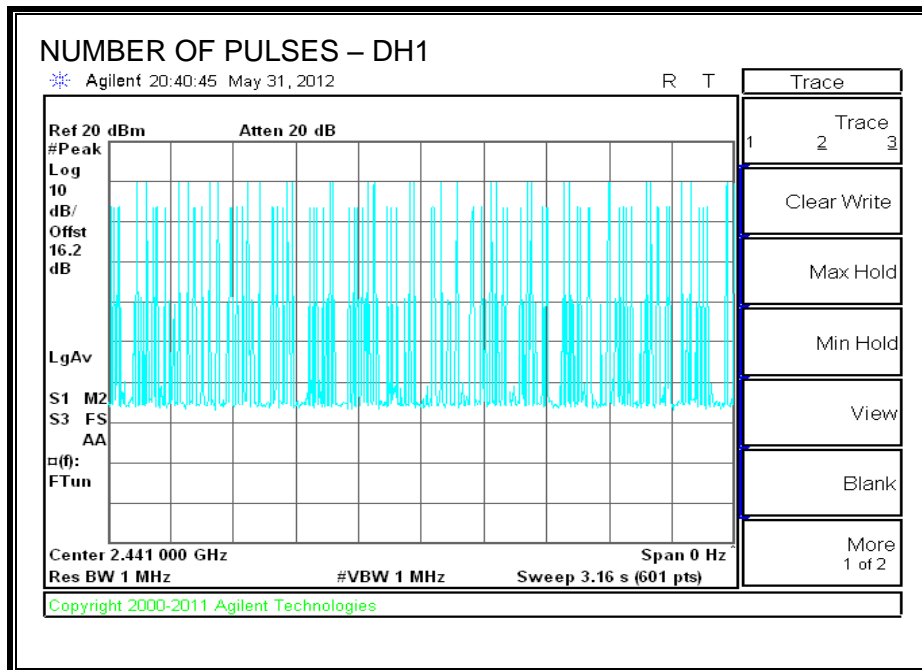

PULSE WIDTH – DH3

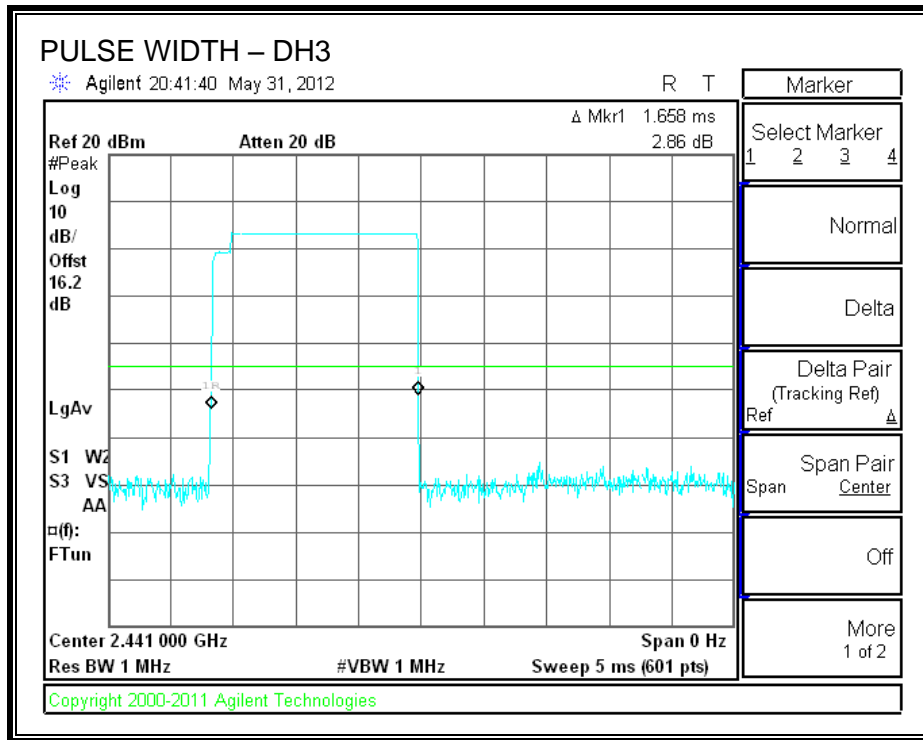

NUMBER OF PULSES IN 3.16 SECOND OBSERVATION PERIOD – DH3

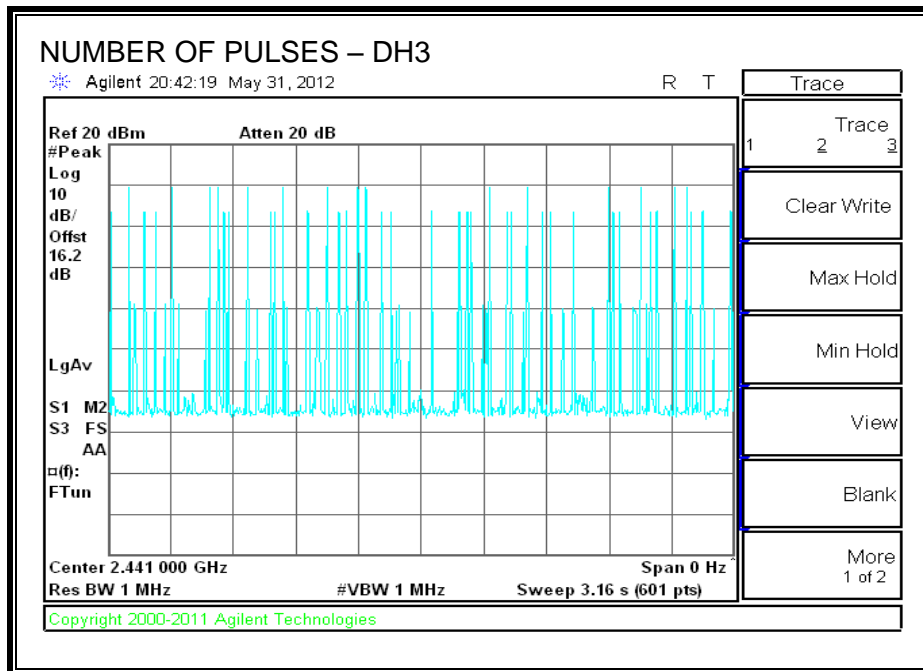

PULSE WIDTH – DH5

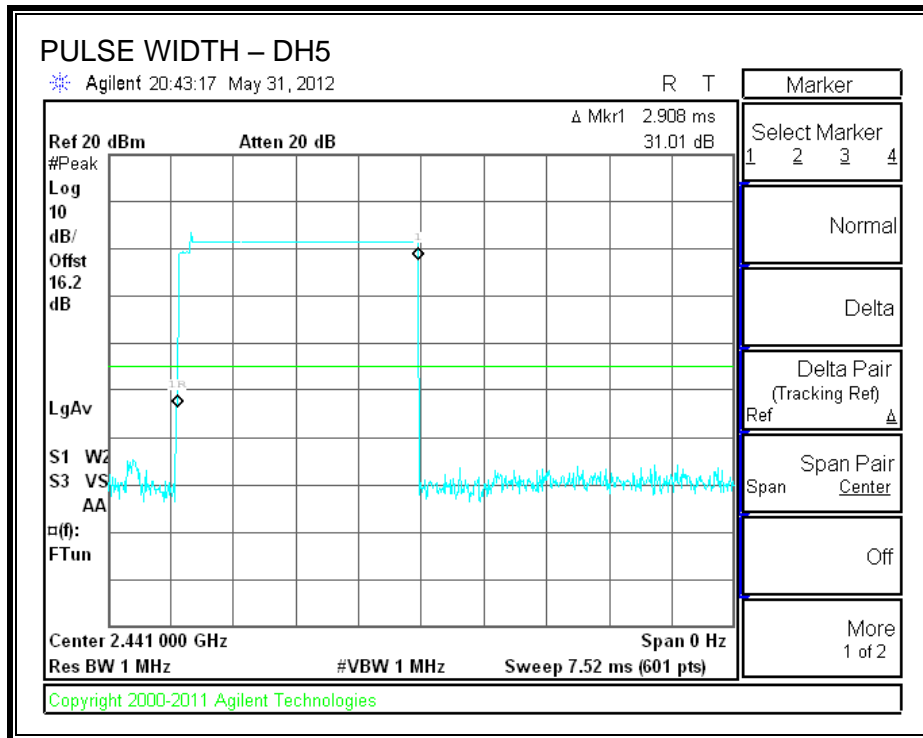

NUMBER OF PULSES IN 3.16 SECOND OBSERVATION PERIOD – DH5

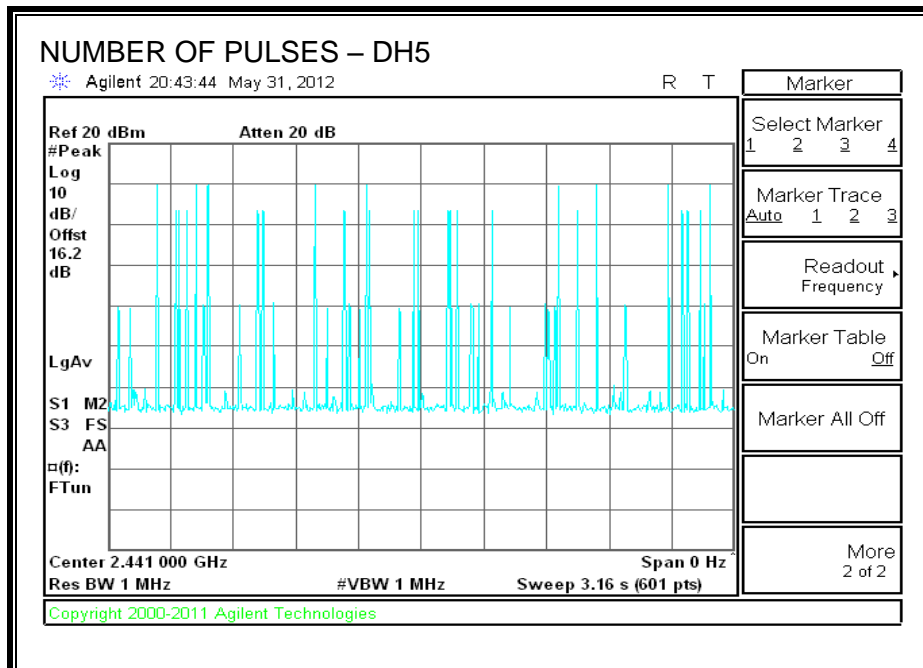

7.2.5. OUTPUT POWER

LIMIT

§15.247 (b) (1)

The maximum antenna gain is less than 6 dBi, therefore the limit is 30 dBm.

TEST PROCEDURE

The transmitter output is connected to a spectrum analyzer the analyzer bandwidth is set to a value greater than the 20 dB bandwidth of the EUT.

RESULTS

Channel	Frequency (MHz)	Output Power (dBm)	Limit (dBm)	Margin (dB)
Low	2402	9.94	30.00	-20.06
Middle	2441	10.16	30.00	-19.84
High	2480	9.11	30.00	-20.89

OUTPUT POWER

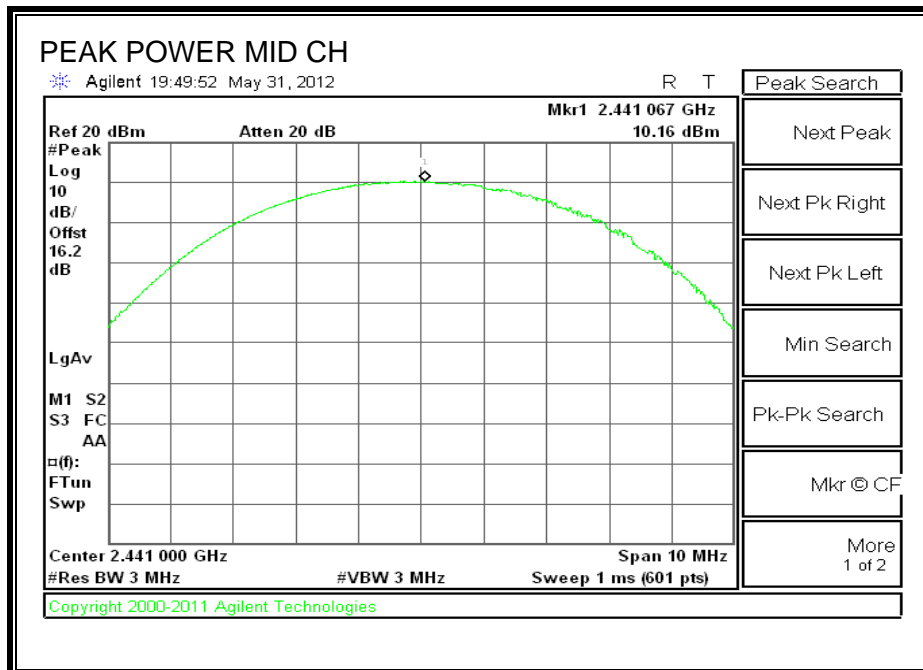
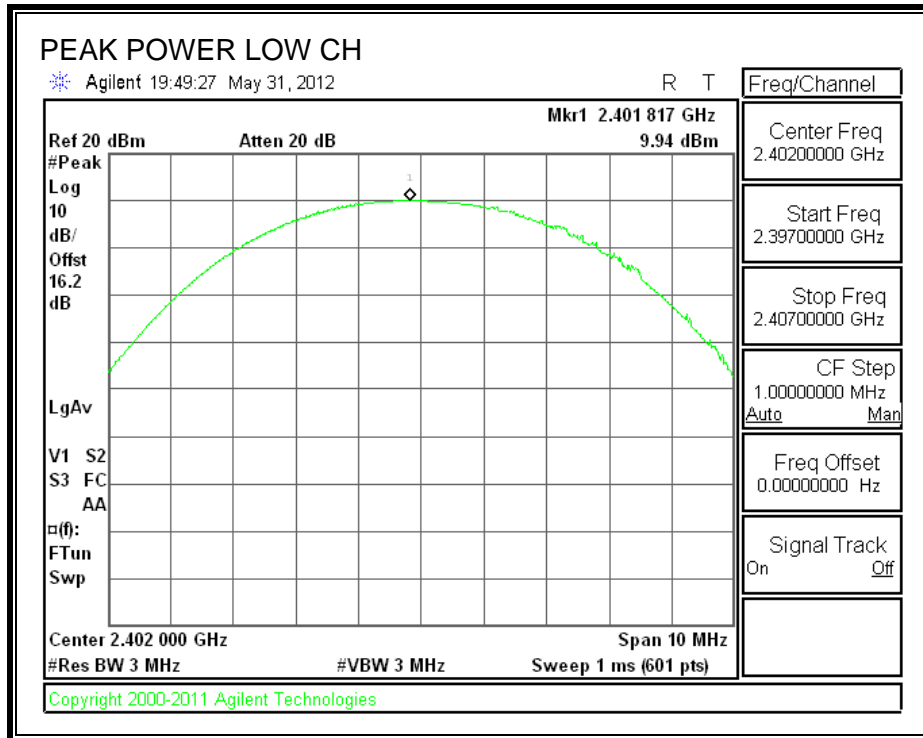

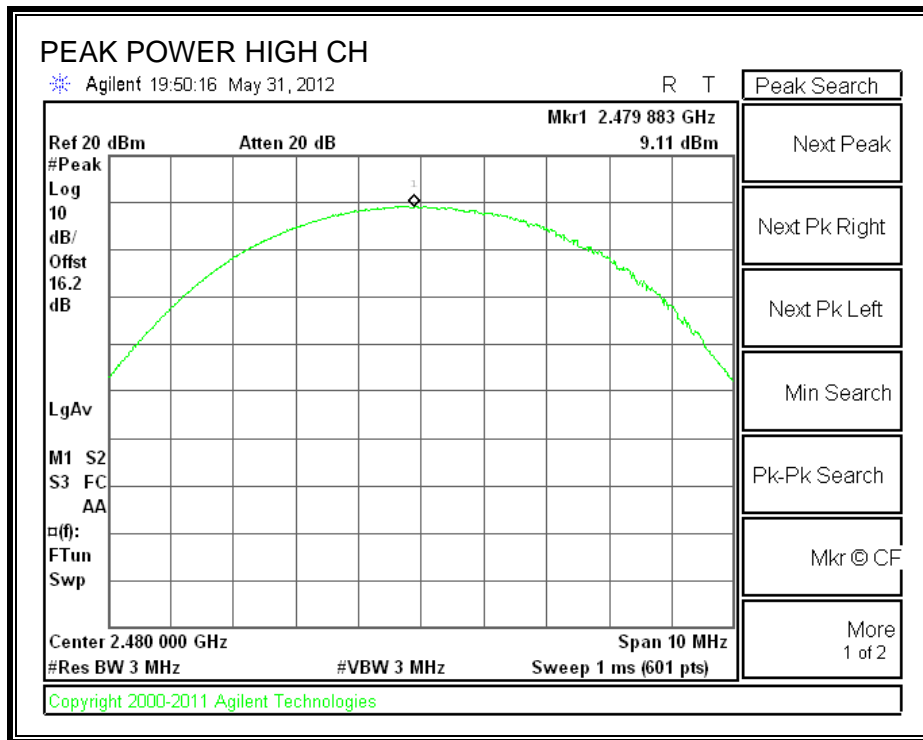

7.2.6. AVERAGE POWER

LIMIT

None; for reporting purposes only.

TEST PROCEDURE

The transmitter output is connected to a power meter.

RESULTS

The cable assembly insertion loss of 11.2 dB (including 10 dB pad and 1.2 dB cable) was entered as an offset in the power meter to allow for direct reading of power.

Channel	Frequency (MHz)	Average Power (dBm)
Low	2402	7.70
Middle	2441	7.80
High	2480	6.70

7.2.7. CONDUCTED SPURIOUS EMISSIONS

LIMITS

FCC §15.247 (d)

Limit = -20 dBc

TEST PROCEDURE

The transmitter output is connected to a spectrum analyzer. The resolution bandwidth is set to 100 kHz. The video bandwidth is set to 300 kHz.

The spectrum from 30 MHz to 26 GHz is investigated with the transmitter set to the lowest, middle, and highest channels.

The bandedges at 2.4 and 2.4835 GHz are investigated with the transmitter set to the normal hopping mode.

RESULTS

SPURIOUS EMISSIONS, LOW CHANNEL

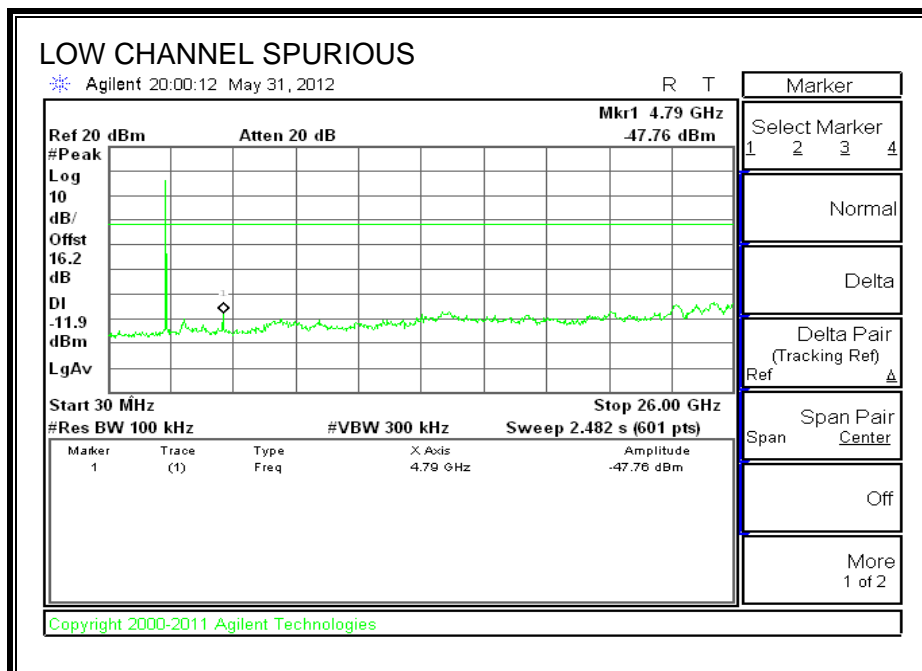
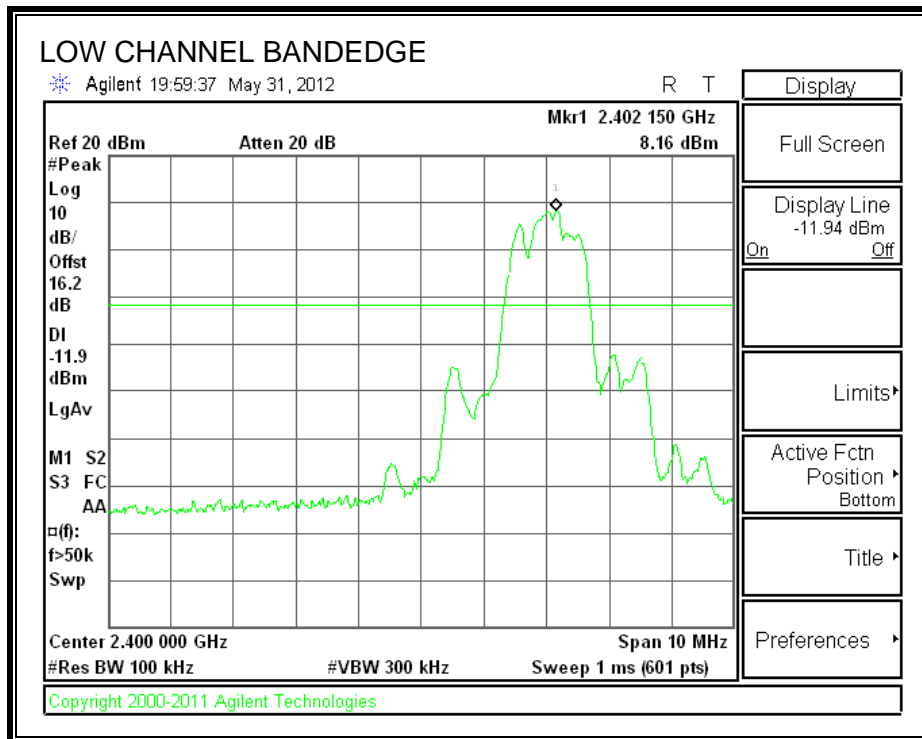

SPURIOUS EMISSIONS, MID CHANNEL

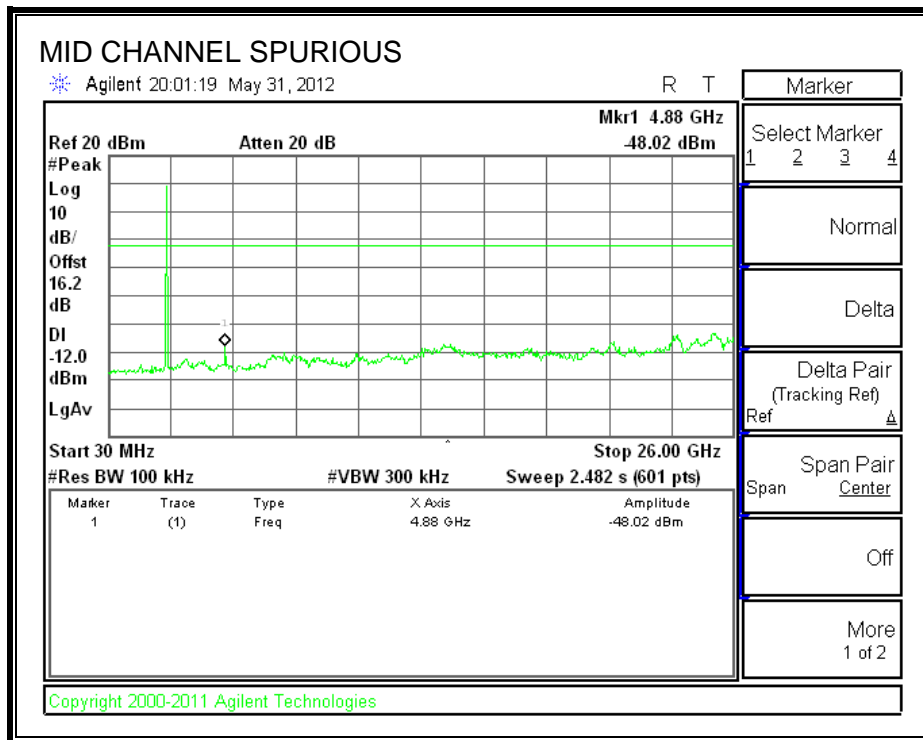
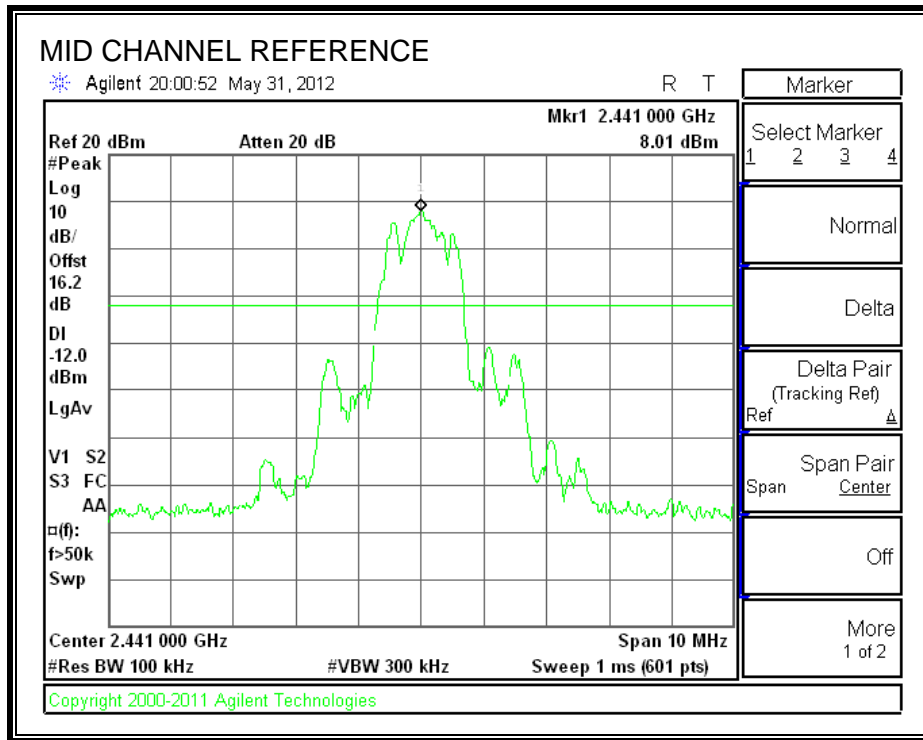

SPURIOUS EMISSIONS, HIGH CHANNEL

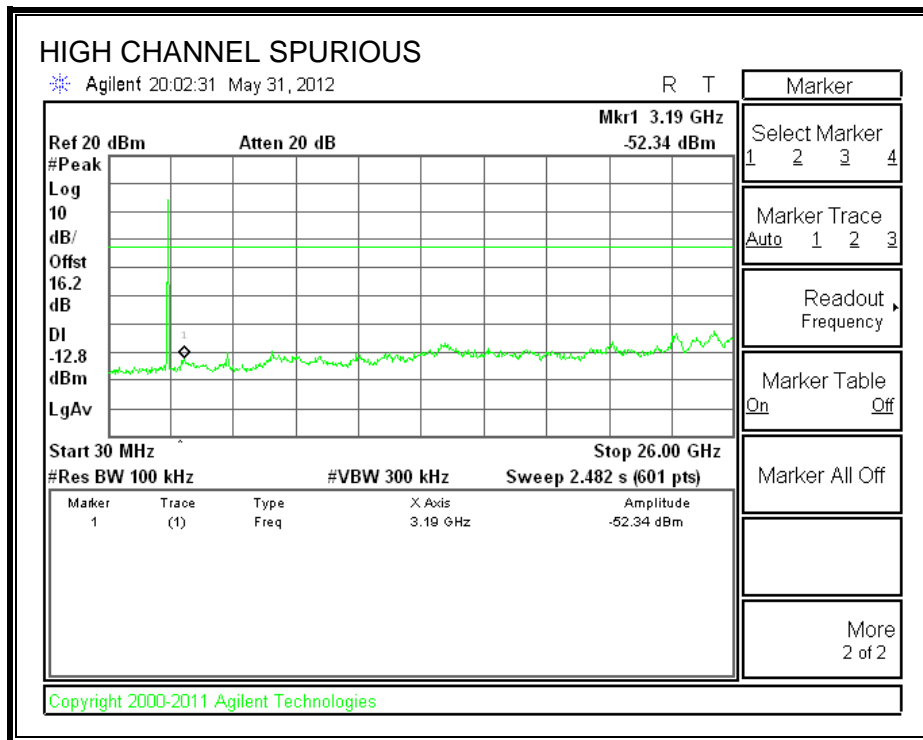
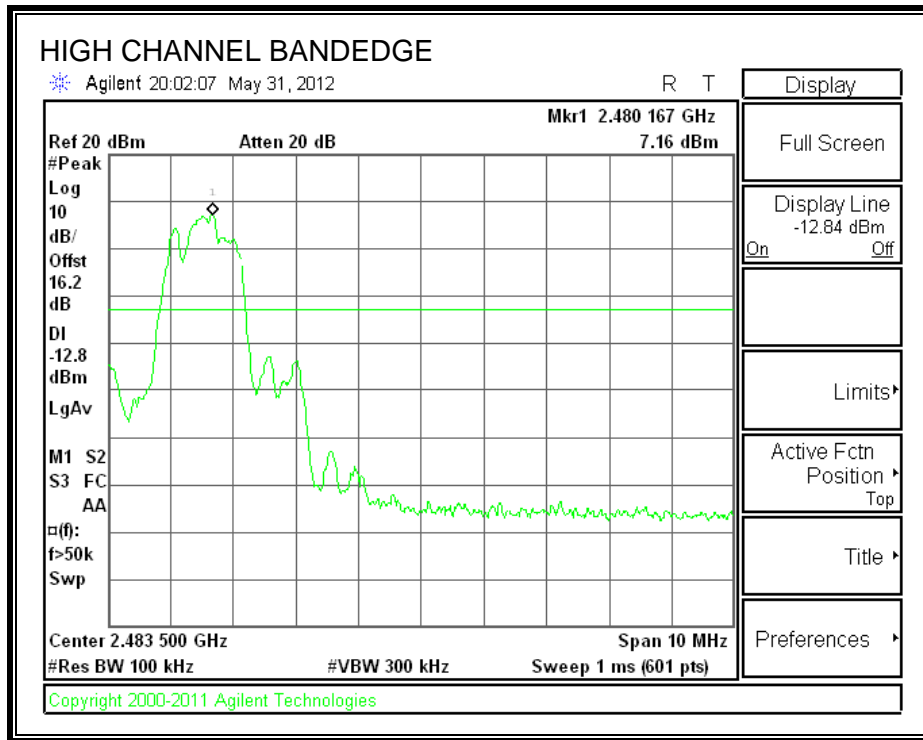

SPURIOUS BANDEDGE EMISSIONS WITH HOPPING ON

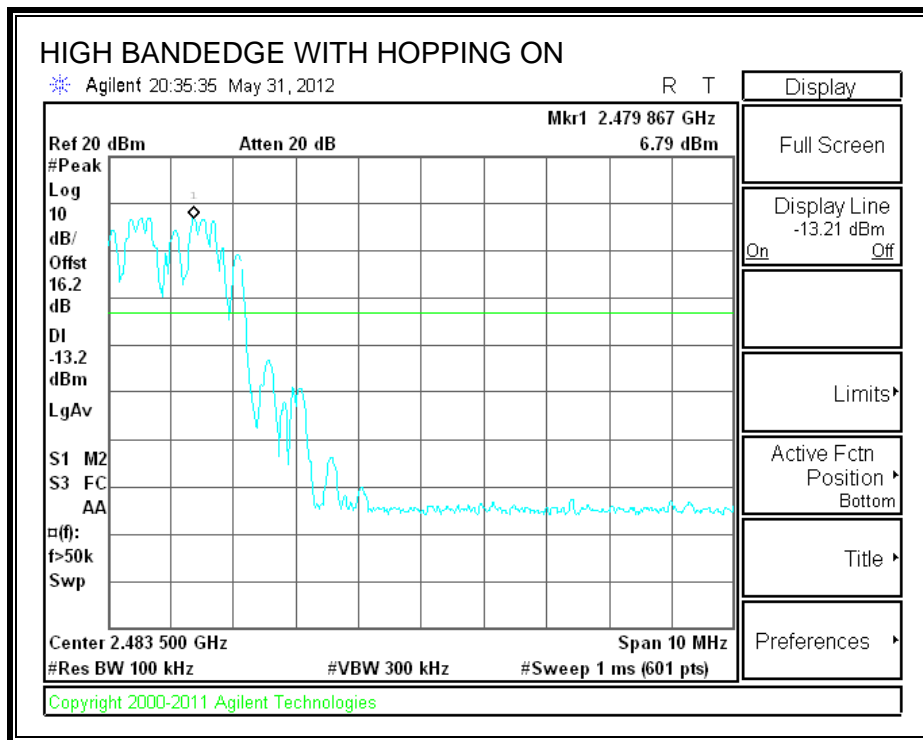
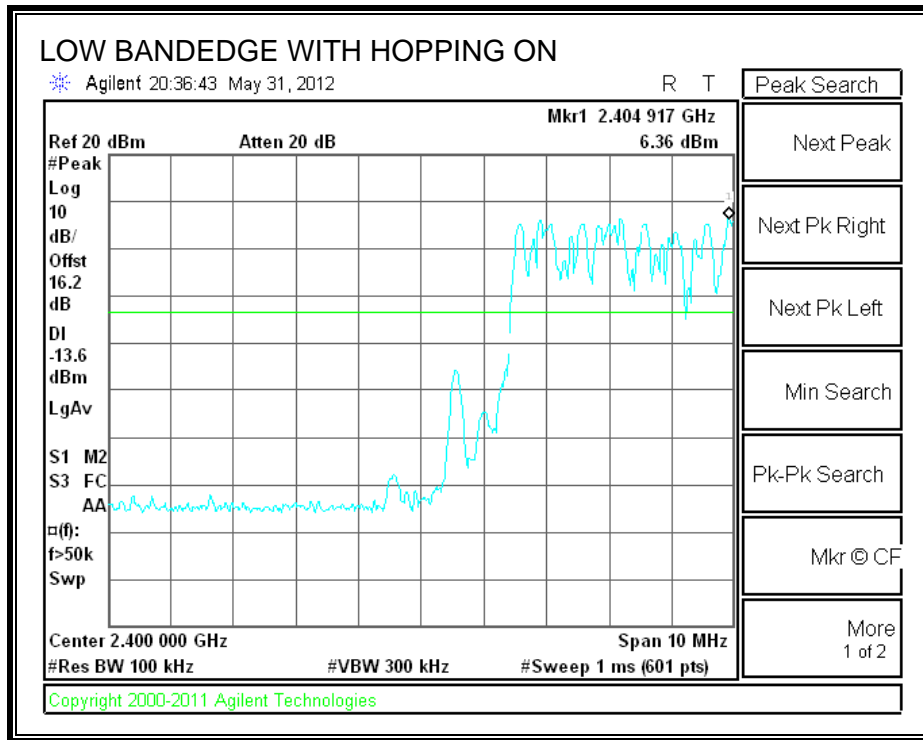

8. RADIATED TEST RESULTS

8.1. LIMITS AND PROCEDURE

LIMITS

FCC §15.205 and §15.209

Frequency Range (MHz)	Field Strength Limit (uV/m) at 3 m	Field Strength Limit (dBuV/m) at 3 m
30 - 88	100	40
88 - 216	150	43.5
216 - 960	200	46
Above 960	500	54

TEST PROCEDURE

The EUT is placed on a non-conducting table 80 cm above the ground plane. The antenna to EUT distance is 3 meters. The EUT is configured in accordance with ANSI C63.4. The EUT is set to transmit in a continuous mode.

For measurements below 1 GHz the resolution bandwidth is set to 100 kHz for peak detection measurements or 120 kHz for quasi-peak detection measurements. Peak detection is used unless otherwise noted as quasi-peak.

For measurements above 1 GHz the resolution bandwidth is set to 1 MHz, then the video bandwidth is set to 1 MHz for peak measurements and 10 Hz for average measurements.

The spectrum from 30 MHz to 26 GHz is investigated with the transmitter set to the lowest, middle, and highest channels in the 2.4 GHz band.

The frequency range of interest is monitored at a fixed antenna height and EUT azimuth. The EUT is rotated through 360 degrees to maximize emissions received. The antenna is scanned from 1 to 4 meters above the ground plane to further maximize the emission. Measurements are made with the antenna polarized in both the vertical and the horizontal positions.

8.2. TRANSMITTER ABOVE 1 GHz

8.2.1. BASIC DATA RATE GFSK MODULATION

RESTRICTED BANDEDGE (LOW CHANNEL, HORIZONTAL)

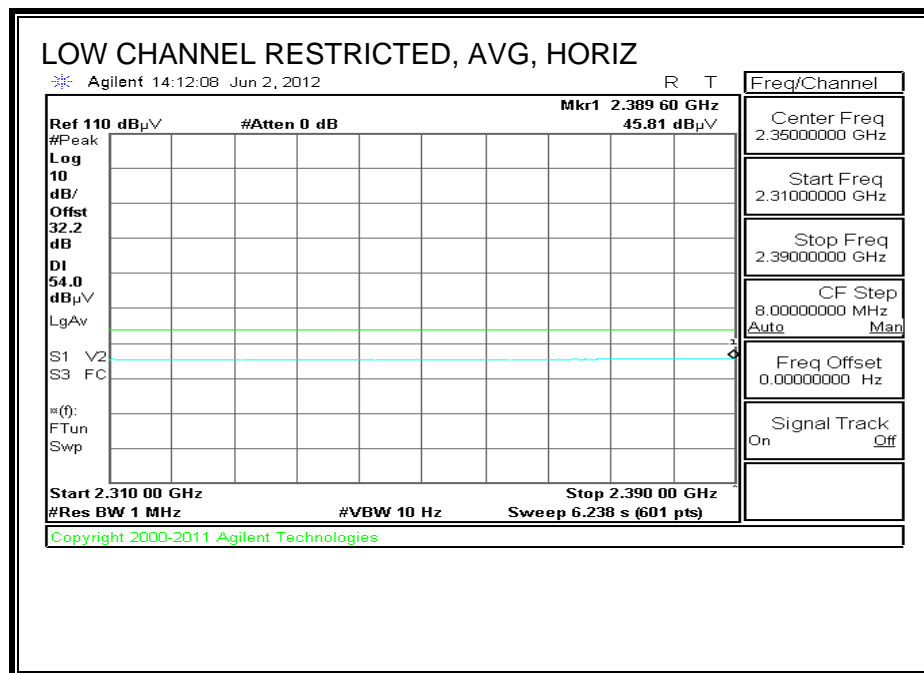
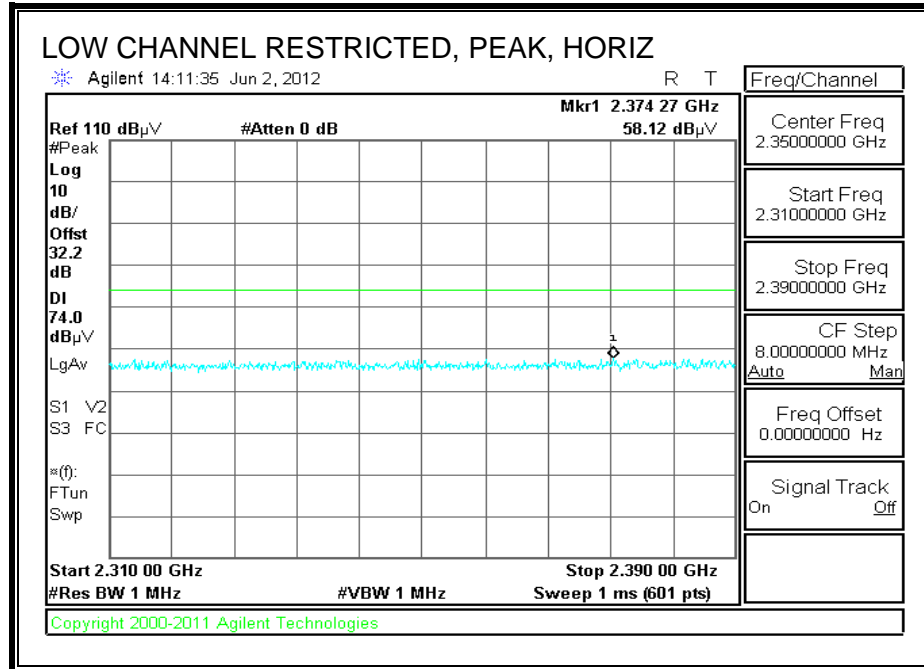

RESTRICTED BANEDGE (LOW CHANNEL, VERTICAL)

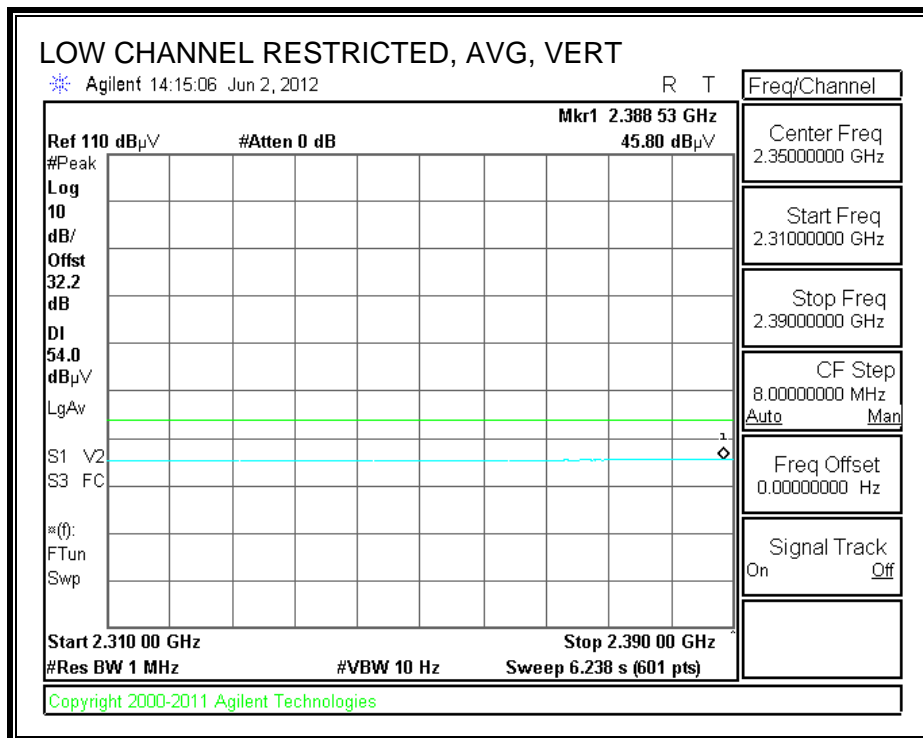
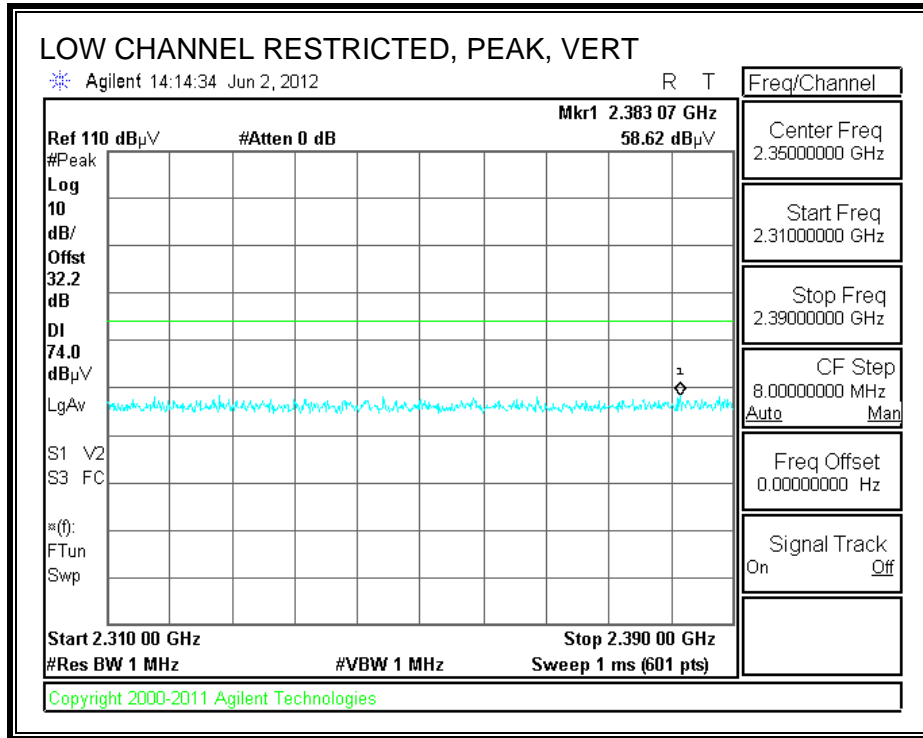

RESTRICTED BANDEGE (HIGH CHANNEL, HORIZONTAL)

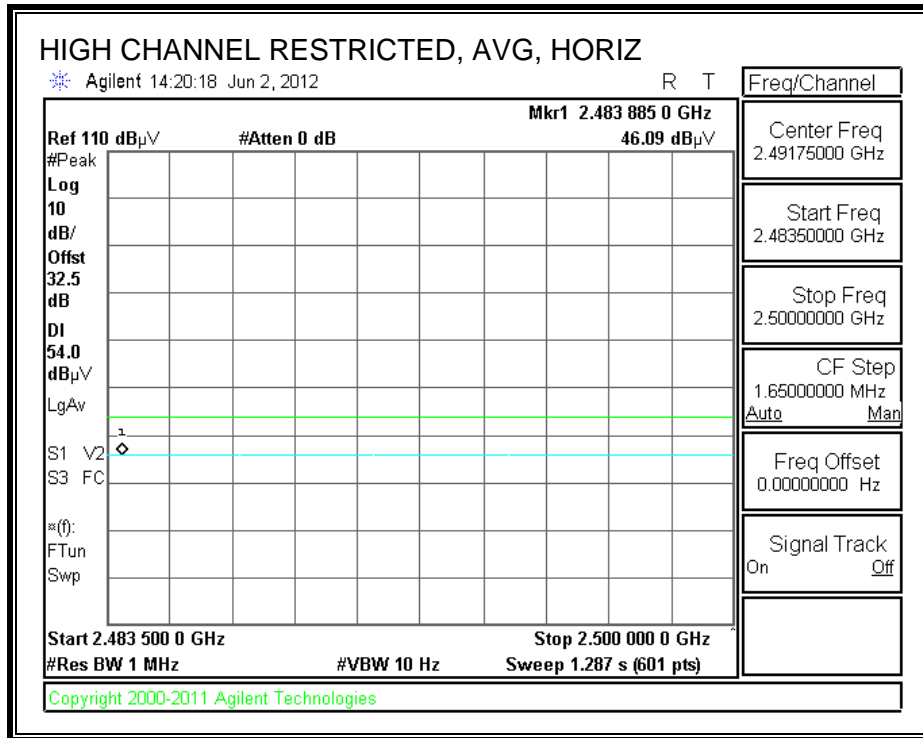
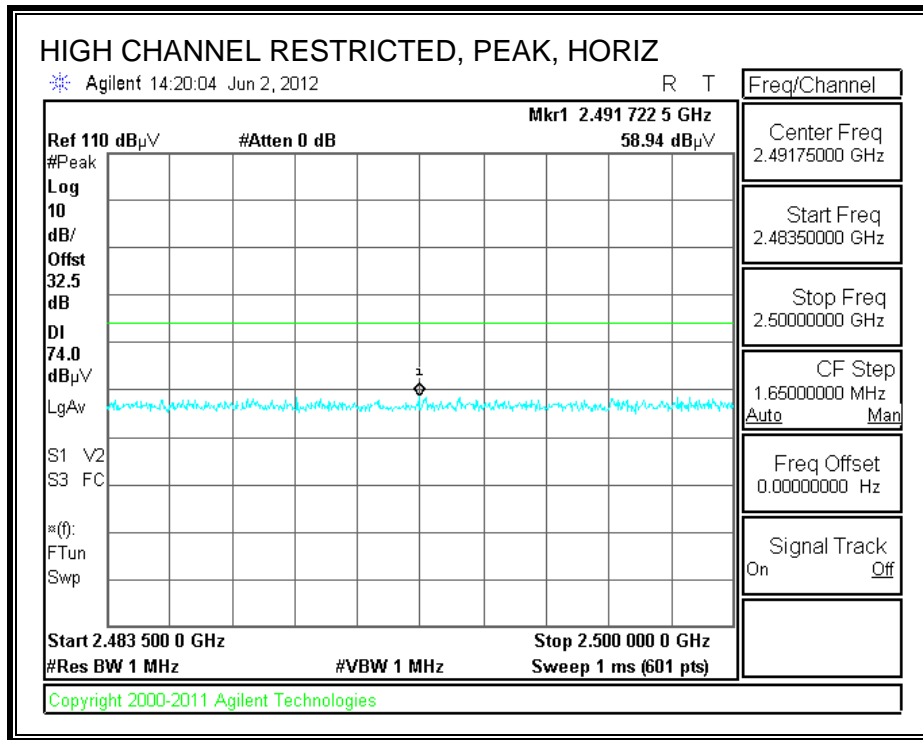

RESTRICTED BANEDGE (HIGH CHANNEL, VERTICAL)

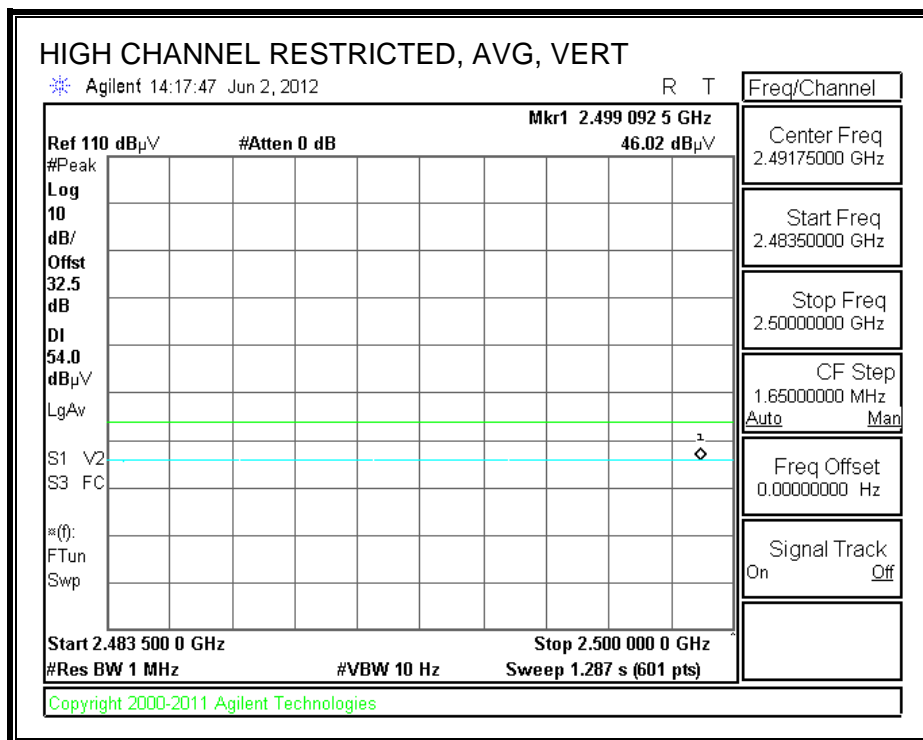
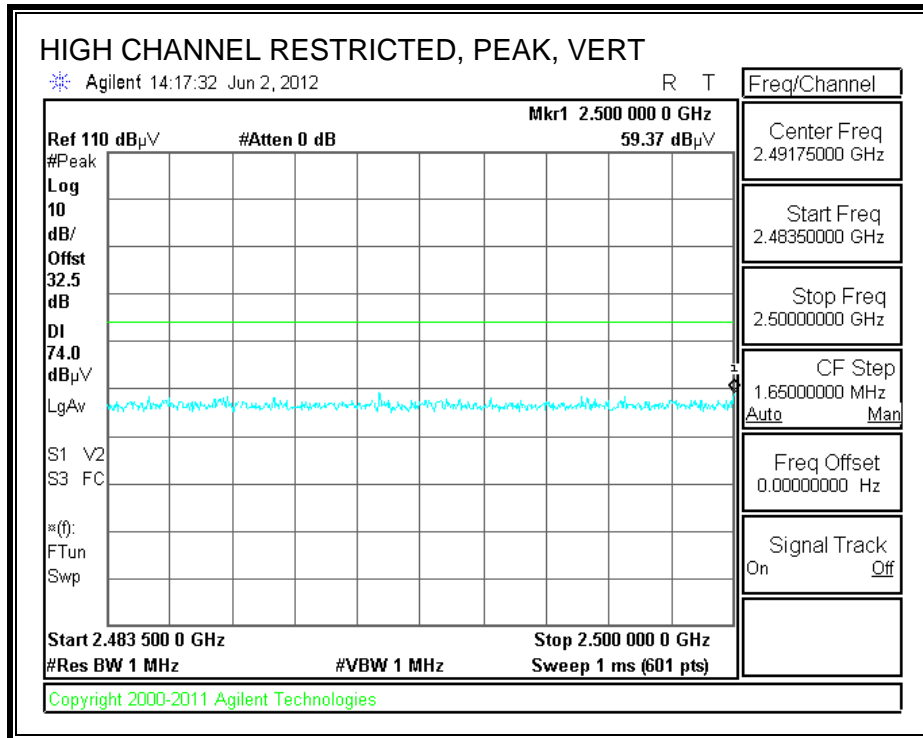

HARMONICS AND SPURIOUS EMISSIONS

High Frequency Measurement													
Compliance Certification Services, Fremont 5m Chamber													
Test Engr:		Chin Pang											
Date:		06/02/12											
Project #:		12I14430											
Company:		Samsung											
Test Target:		FCC 15.247											
Mode Oper:		TX, BT GFSK											
f	Measurement Frequency			Amp	Preamp Gain			Average Field Strength Limit					
Dist	Distance to Antenna			D Corr	Distance Correct to 3 meters			Peak Field Strength Limit					
Read	Analyzer Reading			Avg	Average Field Strength @ 3 m			Margin vs. Average Limit					
AF	Antenna Factor			Peak	Calculated Peak Field Strength			Margin vs. Peak Limit					
CL	Cable Loss			HPF	High Pass Filter								
f	Dist	Read	AF	CL	Amp	D Corr	Fltr	Corr.	Limit	Margin	Ant. Pol.	Det.	Notes
GHz	(m)	dBuV	dB/m	dB	dB	dB	dB	dBuV/m	dBuV/m	dB	V/H	P/A/QP	
Low Ch, 2402MHz													
4.804	3.0	47.9	33.1	6.3	-34.8	0.0	0.0	52.4	74.0	-21.6	H	P	
4.804	3.0	35.8	33.1	6.3	-34.8	0.0	0.0	40.3	54.0	-13.7	H	A	
4.804	3.0	49.1	33.1	6.3	-34.8	0.0	0.0	53.7	74.0	-20.3	V	P	
4.804	3.0	36.4	33.1	6.3	-34.8	0.0	0.0	41.0	54.0	-13.0	V	A	
Mid Ch, 2441MHz													
4.882	3.0	43.7	33.1	6.3	-34.8	0.0	0.0	48.3	74.0	-25.7	H	P	
4.882	3.0	32.2	33.1	6.3	-34.8	0.0	0.0	36.8	54.0	-17.2	H	A	
7.323	3.0	56.1	35.8	8.5	-34.9	0.0	0.0	65.5	74.0	-8.5	H	P	
7.323	3.0	39.5	35.8	8.5	-34.9	0.0	0.0	49.0	54.0	-5.0	H	A	
4.882	3.0	44.0	33.1	6.3	-34.8	0.0	0.0	48.6	74.0	-25.4	V	P	
4.882	3.0	32.6	33.1	6.3	-34.8	0.0	0.0	37.2	54.0	-16.8	V	A	
7.323	3.0	59.5	35.8	8.5	-34.9	0.0	0.0	68.9	74.0	-5.1	V	P	
7.323	3.0	41.4	35.8	8.5	-34.9	0.0	0.0	50.8	54.0	-3.2	V	A	
High Ch, 2480MHz													
4.960	3.0	38.9	33.2	6.4	-34.8	0.0	0.0	43.6	74.0	-30.4	H	P	
4.960	3.0	27.9	33.2	6.4	-34.8	0.0	0.0	32.7	54.0	-21.3	H	A	
7.440	3.0	55.9	36.0	8.5	-34.9	0.0	0.0	65.6	74.0	-8.4	H	P	
7.440	3.0	39.3	36.0	8.5	-34.9	0.0	0.0	49.0	54.0	-5.1	H	A	
4.960	3.0	39.6	33.2	6.4	-34.8	0.0	0.0	44.4	74.0	-29.6	V	P	
4.960	3.0	27.6	33.2	6.4	-34.8	0.0	0.0	32.3	54.0	-21.7	V	A	
7.440	3.0	57.1	36.0	8.5	-34.9	0.0	0.0	66.7	74.0	-7.3	V	P	
7.440	3.0	39.9	36.0	8.5	-34.9	0.0	0.0	49.6	54.0	-4.4	V	A	
Rev. 4.1.2.7													
Note: No other emissions were detected above the system noise floor.													

8.2.2. ENHANCED DATA RATE 8PSK MODULATION

RESTRICTED BANDEDGE (LOW CHANNEL, HORIZONTAL)

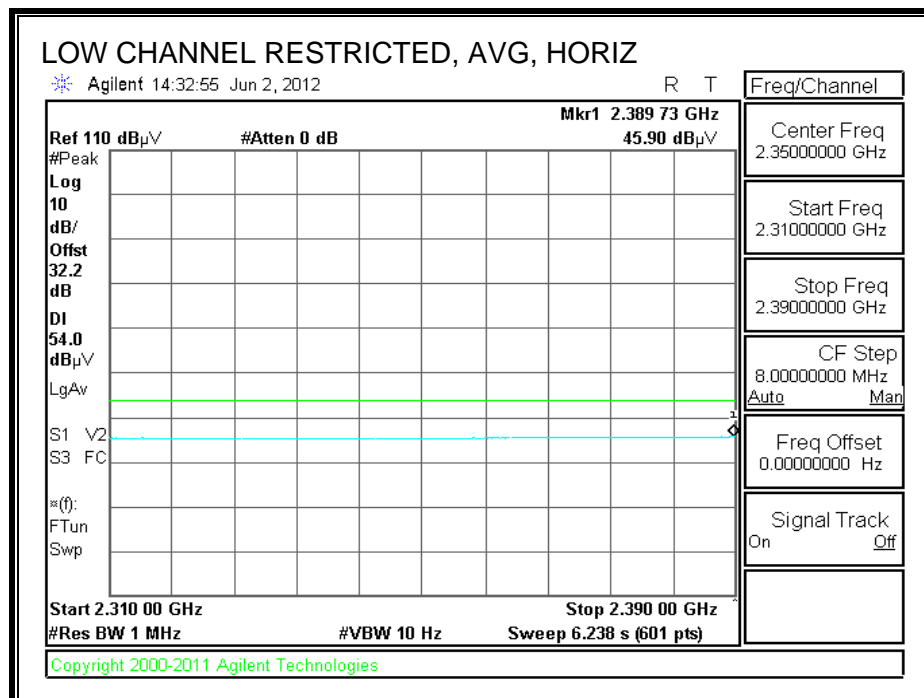
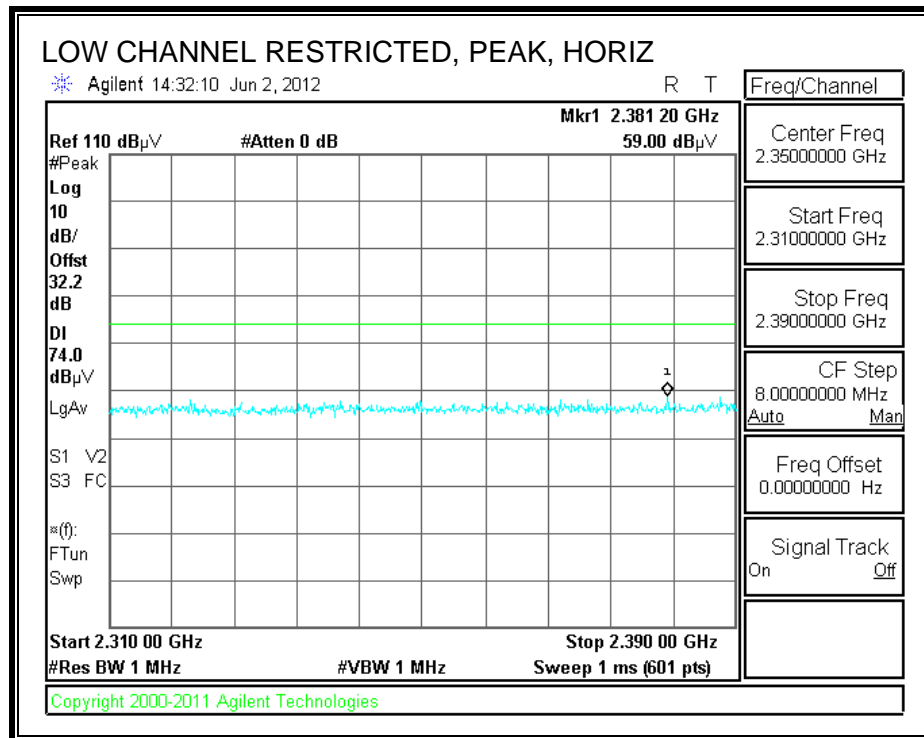

RESTRICTED BANDEDGE (LOW CHANNEL, VERTICAL)

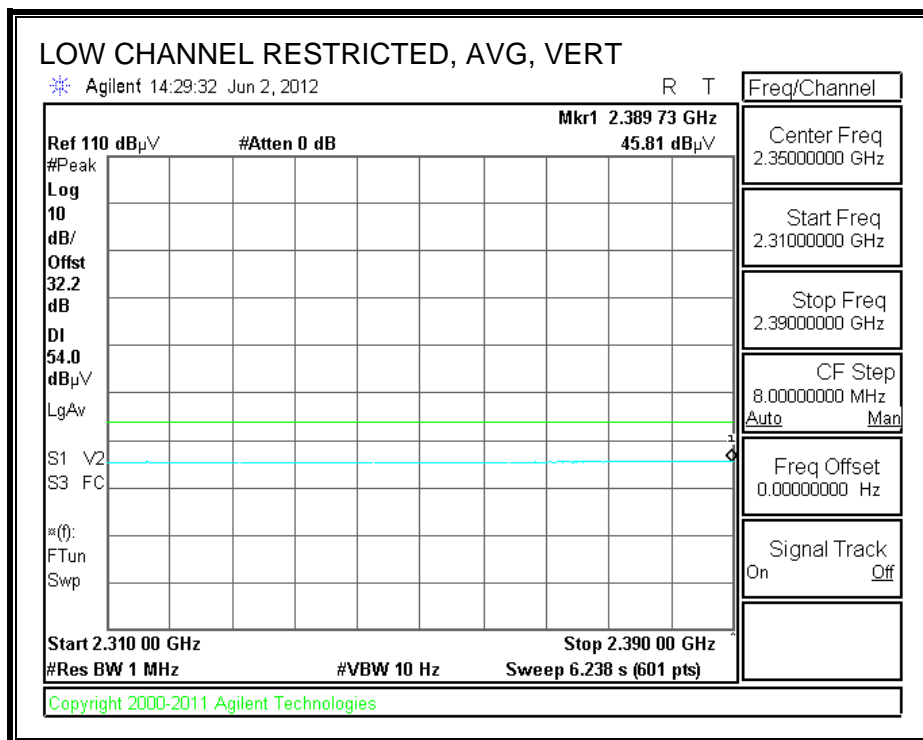
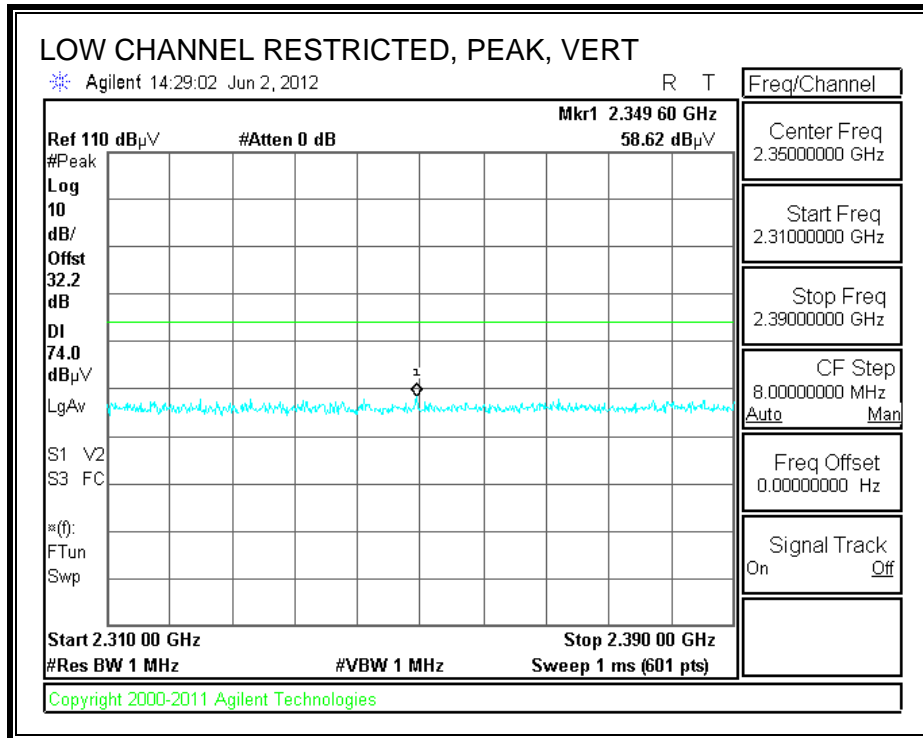

RESTRICTED BANEDGE (HIGH CHANNEL, HORIZONTAL)

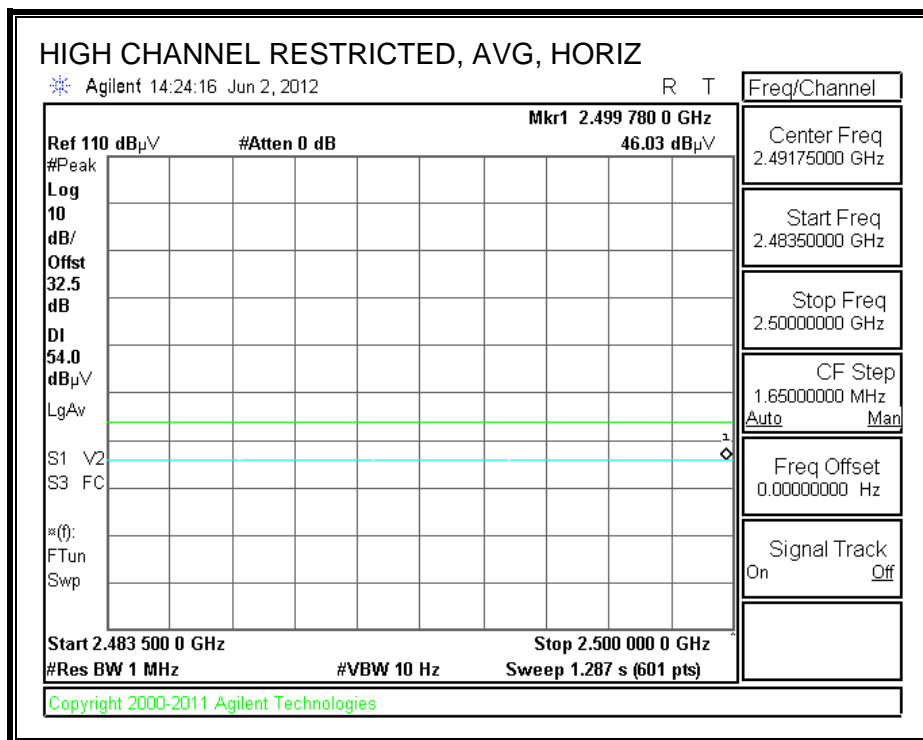
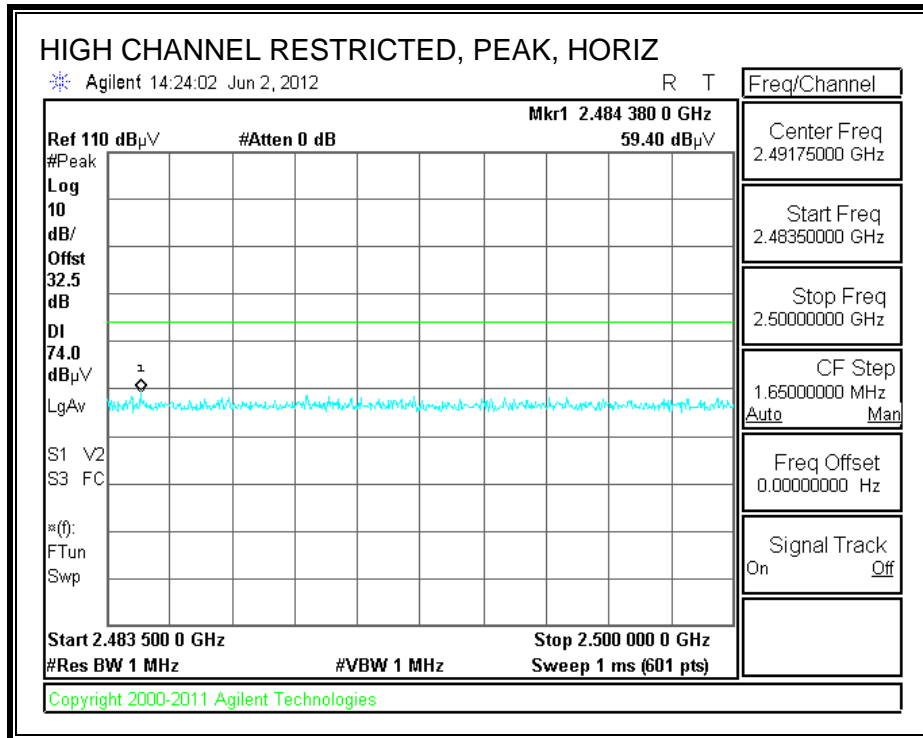

RESTRICTED BANDEDGE (HIGH CHANNEL, VERTICAL)

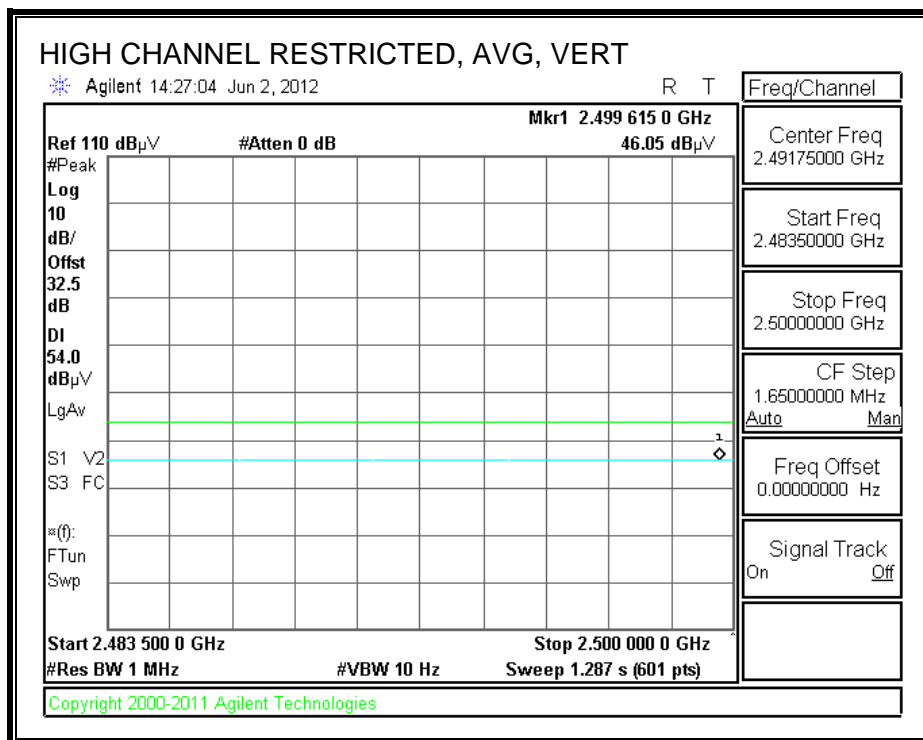
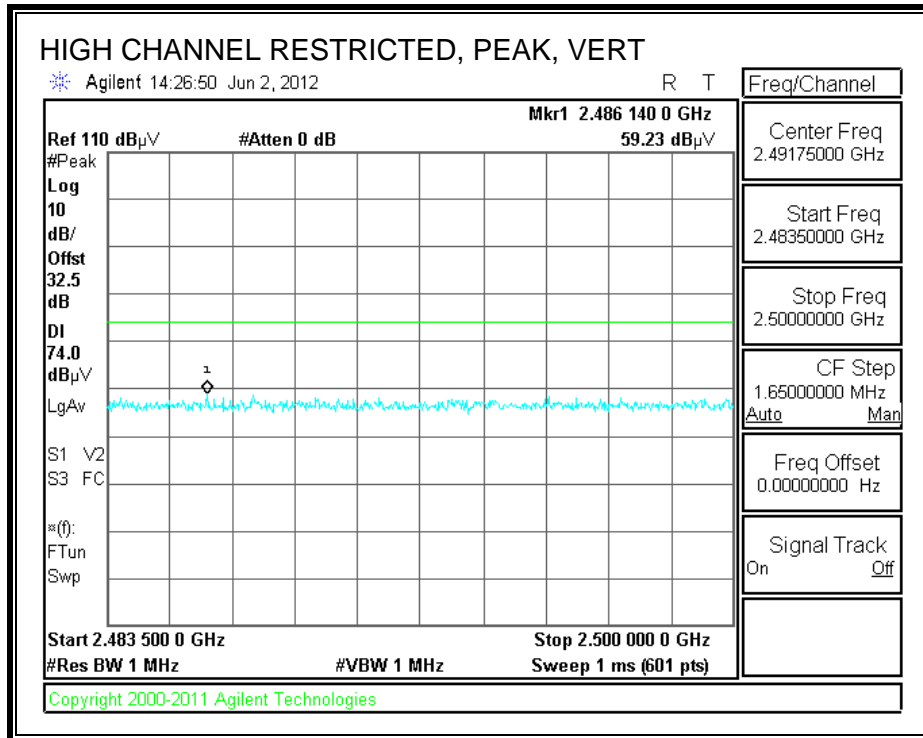

HARMONICS AND SPURIOUS EMISSIONS

High Frequency Measurement													
Compliance Certification Services, Fremont 5m Chamber													
Test Engr:		Chin Pang											
Date:		06/02/12											
Project #:		12114430											
Company:		Samsung											
Test Target:		FCC 15.247											
Mode Oper:		TX, BT 8PSK											
f	Measurement Frequency			Amp	Preamp Gain			Average Field Strength Limit					
Dist	Distance to Antenna			D Corr	Distance Correct to 3 meters			Peak Field Strength Limit					
Read	Analyzer Reading			Avg	Average Field Strength @ 3 m			Margin vs. Average Limit					
AF	Antenna Factor			Peak	Calculated Peak Field Strength			Margin vs. Peak Limit					
CL	Cable Loss			HPF	High Pass Filter								
f	Dist	Read	AF	CL	Amp	D Corr	Fltr	Corr.	Limit	Margin	Ant. Pol.	Det.	Notes
GHz	(m)	dBuV	dB/m	dB	dB	dB	dB	dBuV/m	dBuV/m	dB	V/H	P/A/QP	
Low Ch, 2402MHz													
4.804	3.0	48.4	33.1	6.3	-34.8	0.0	0.0	52.9	74.0	-21.1	V	P	
4.804	3.0	40.8	33.1	6.3	-34.8	0.0	0.0	45.3	54.0	-8.7	V	A	
4.804	3.0	48.5	33.1	6.3	-34.8	0.0	0.0	53.0	74.0	-21.0	V	P	
4.804	3.0	40.6	33.1	6.3	-34.8	0.0	0.0	45.2	54.0	-8.8	V	A	
Mid Ch, 2441MHz													
4.882	3.0	45.0	33.1	6.3	-34.8	0.0	0.0	49.6	74.0	-24.4	V	P	
4.882	3.0	37.0	33.1	6.3	-34.8	0.0	0.0	41.6	54.0	-12.4	V	A	
7.323	3.0	54.0	35.8	8.5	-34.9	0.0	0.0	63.4	74.0	-10.6	V	P	
7.323	3.0	42.8	35.8	8.5	-34.9	0.0	0.0	52.2	54.0	-1.8	V	A	
4.882	3.0	43.6	33.1	6.3	-34.8	0.0	0.0	48.3	74.0	-25.7	H	P	
4.882	3.0	34.9	33.1	6.3	-34.8	0.0	0.0	39.6	54.0	-14.4	H	A	
7.323	3.0	50.5	35.8	8.5	-34.9	0.0	0.0	59.9	74.0	-14.1	H	P	
7.323	3.0	40.3	35.8	8.5	-34.9	0.0	0.0	49.8	54.0	-4.2	H	A	
High Ch, 2480MHz													
4.960	3.0	41.8	33.2	6.4	-34.8	0.0	0.0	46.6	74.0	-27.4	V	P	
4.960	3.0	33.3	33.2	6.4	-34.8	0.0	0.0	38.1	54.0	-15.9	V	A	
7.440	3.0	50.5	36.0	8.5	-34.9	0.0	0.0	60.2	74.0	-13.8	V	P	
7.440	3.0	40.3	36.0	8.5	-34.9	0.0	0.0	50.0	54.0	-4.0	V	A	
4.960	3.0	42.0	33.2	6.4	-34.8	0.0	0.0	46.8	74.0	-27.2	H	P	
4.960	3.0	33.1	33.2	6.4	-34.8	0.0	0.0	37.9	54.0	-16.1	H	A	
7.440	3.0	51.8	36.0	8.5	-34.9	0.0	0.0	61.5	74.0	-12.5	H	P	
7.440	3.0	39.6	36.0	8.5	-34.9	0.0	0.0	49.3	54.0	-4.7	H	A	
Rev. 4.1.2.7													
Note: No other emissions were detected above the system noise floor.													

8.3. WORST-CASE BELOW 1 GHz

SPURIOUS EMISSIONS 30 TO 1000 MHz (WORST-CASE CONFIGURATION, HORIZONTAL)

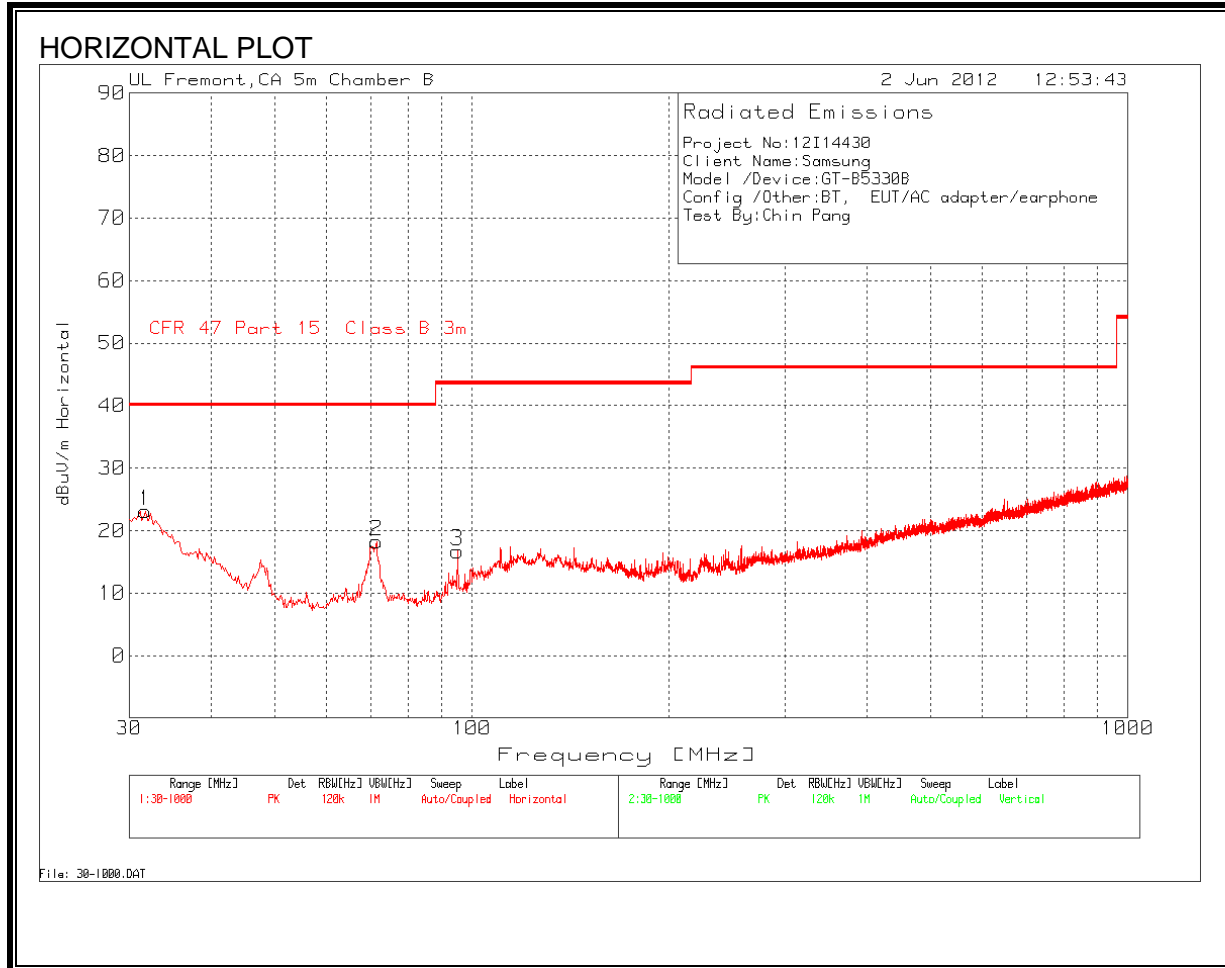

SPURIOUS EMISSIONS 30 TO 1000 MHz (WORST-CASE CONFIGURATION, VERTICAL)

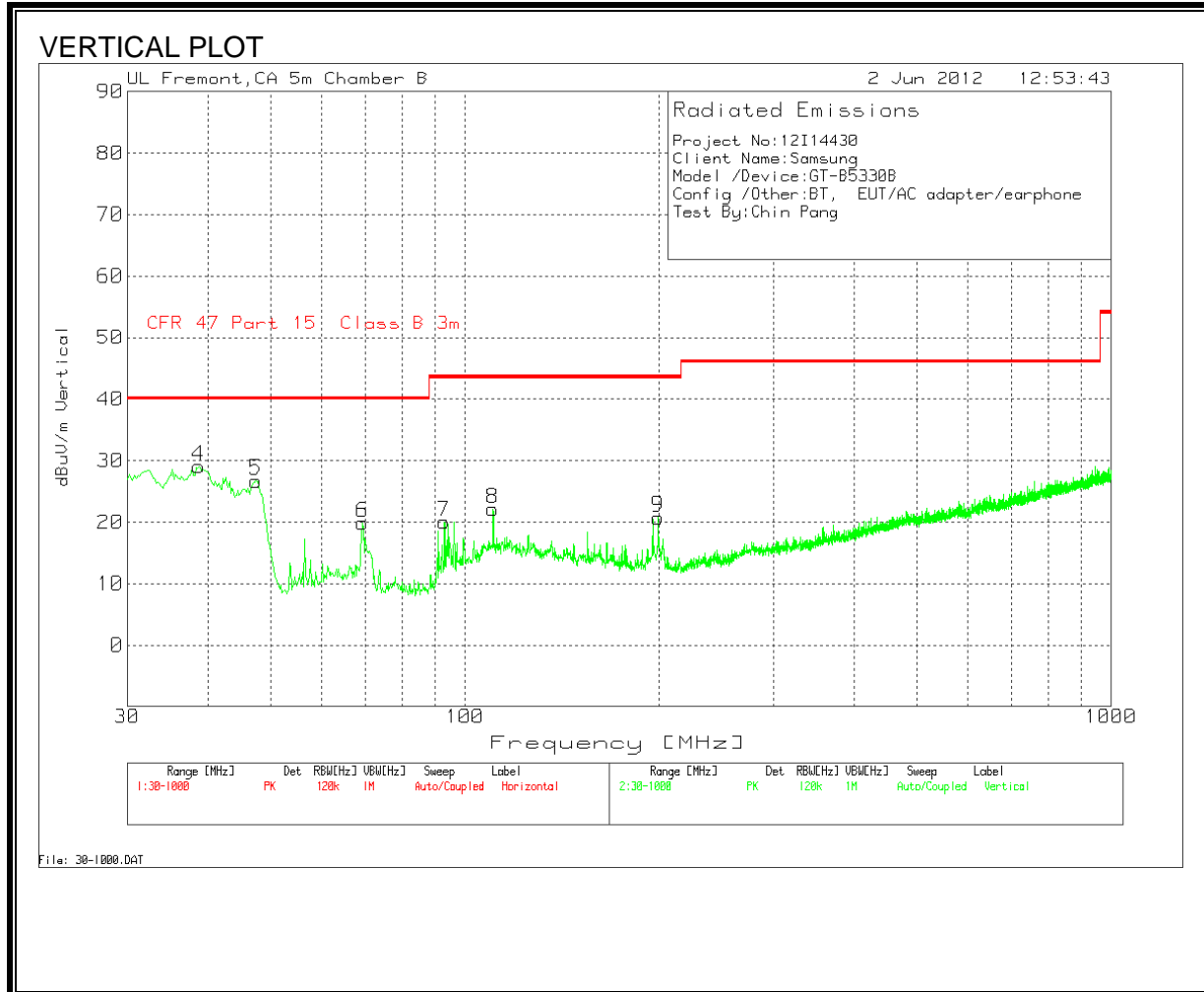

HORIZONTAL & VERTICAL DATA

Project No:12I14430								
Client Name:Samsung								
Model /Device:GT-B5330B								
Config /Other:BT, EUT/AC adapter/earphone								
Test By:Chin Pang								
Horizontal 30 - 1000MHz								
Test Frequency	Meter Res	Detector	T122 Sunol	5mB Amp	dBuV/m	CFR 47 Part 15	Margin	Polarity
31.7446	32.2	PK	20.1	-29.2	23.1	40	-16.9	Horz
71.4828	38.87	PK	8.2	-28.8	18.27	40	-21.73	Horz
94.9381	36.48	PK	8.8	-28.6	16.68	43.5	-26.82	Horz
Vertical 30 - 1000MHz								
Test Frequency	Meter Res	Detector	T122 Sunol	5mB Amp	dBuV/m	CFR 47 Part 15	Margin	Polarity
38.723	43.48	PK	14.8	-29.2	29.08	40	-10.92	Vert
47.446	46.77	PK	9.1	-29.1	26.77	40	-13.23	Vert
69.3505	40.67	PK	8.1	-28.9	19.87	40	-20.13	Vert
92.8058	40.36	PK	8.3	-28.6	20.06	43.5	-23.44	Vert
110.4456	37.95	PK	12.7	-28.5	22.15	43.5	-21.35	Vert
199.0328	35.68	PK	12.7	-27.6	20.78	43.5	-22.72	Vert

9. AC POWER LINE CONDUCTED EMISSIONS

LIMITS

FCC §15.207 (a)

RSS-Gen 7.2.2

Frequency of Emission (MHz)	Conducted Limit (dBuV)	
	Quasi-peak	Average
0.15-0.5	66 to 56*	56 to 46*
0.5-5	56	46
5-30	60	50

*Decreases with the logarithm of the frequency.

TEST PROCEDURE

The EUT is placed on a non-conducting table 40 cm from the vertical ground plane and 80 cm above the horizontal ground plane. The EUT is configured in accordance with ANSI C63.4.

The receiver is set to a resolution bandwidth of 9 kHz. Peak detection is used unless otherwise noted as quasi-peak or average.

Line conducted data is recorded for both NEUTRAL and HOT lines.

RESULTS

6 WORST EMISSIONS

Project No:12I14430									
Client Name:Samsung									
Model/Device:BT(Worst Case)									
Test Volt/Freq:115V 60Hz									
Test By:Chin Pang									
Line-L1 .15 - 30MHz									
Test Frequency	Meter Rea	Detector	T24 IL L1.TXT	LC Cables 1	dB(uVolts)	CFR 47 Part 15	Margin	CFR 47 Part	Margin
0.357	43.67	PK	0.1	0	43.77	58.8	-15.03	-	-
0.357	36.6	Av	0.1	0	36.7	-	-	48.8	-12.1
1.113	47.14	PK	0.1	0	47.24	56	-8.76	-	-
1.113	15.23	Av	0.1	0	15.33	-	-	46	-30.67
4.02	36.98	PK	0.1	0.1	37.18	56	-18.82	-	-
4.02	23.21	Av	0.1	0.1	23.41	-	-	46	-22.59
Line-L2 .15 - 30MHz									
Test Frequency	Meter Rea	Detector	T24 IL L2.TXT	LC Cables 2	dB(uVolts)	CFR 47 Part 15	Margin	CFR 47 Part	Margin
0.204	38.19	PK	0.1	0	38.29	63.4	-25.11	-	-
0.204	19.44	Av	0.1	0	19.54	-	-	53.4	-33.86
0.3615	40.2	PK	0.1	0	40.3	58.7	-18.4	-	-
0.3615	30.85	Av	0.1	0	30.95	-	-	48.7	-17.75
4.0335	32	PK	0.1	0.1	32.2	56	-23.8	-	-
4.0335	18.81	Av	0.1	0.1	19.01	-	-	46	-26.99

LINE 1 RESULTS

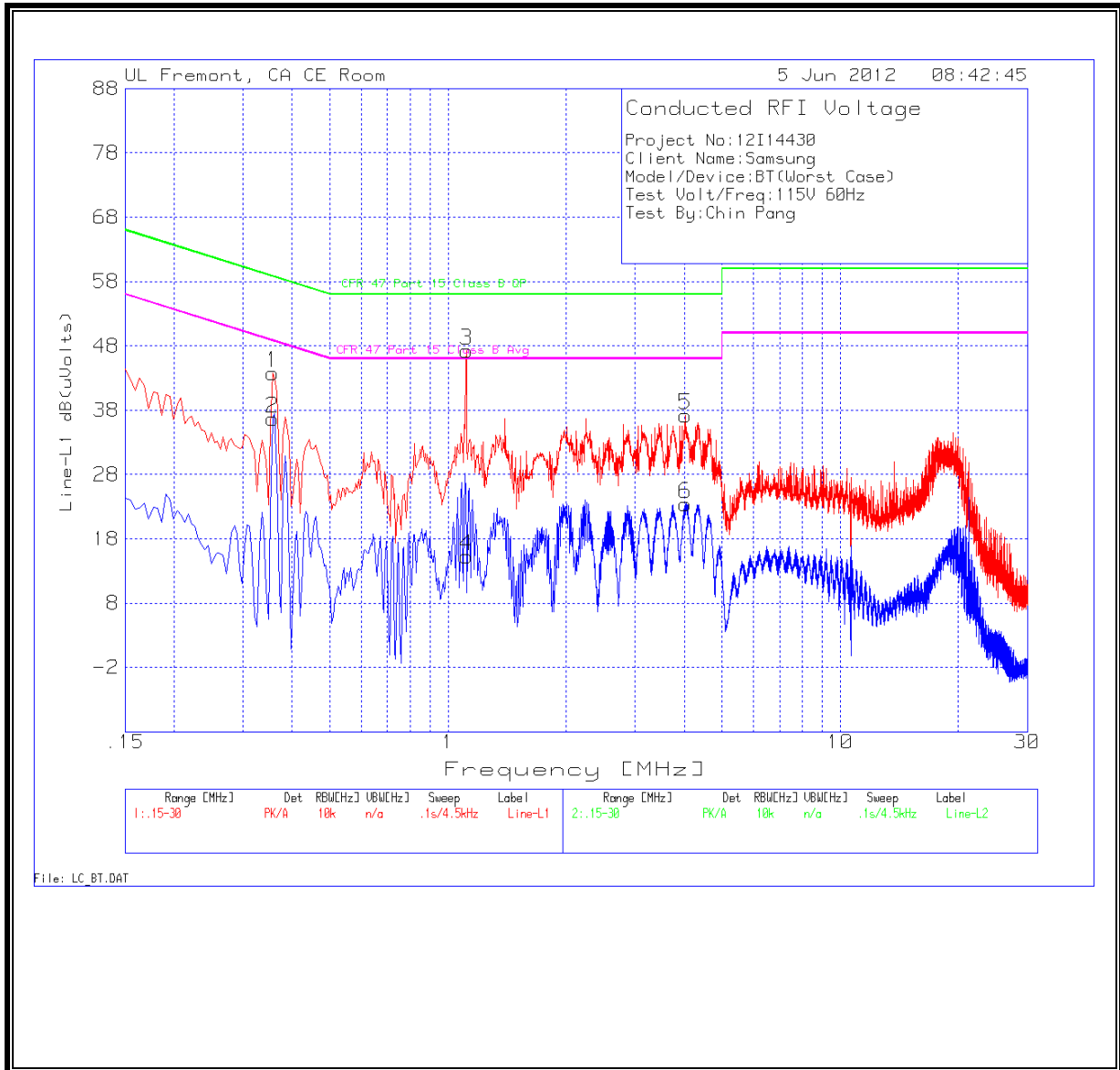

LINE 2 RESULTS

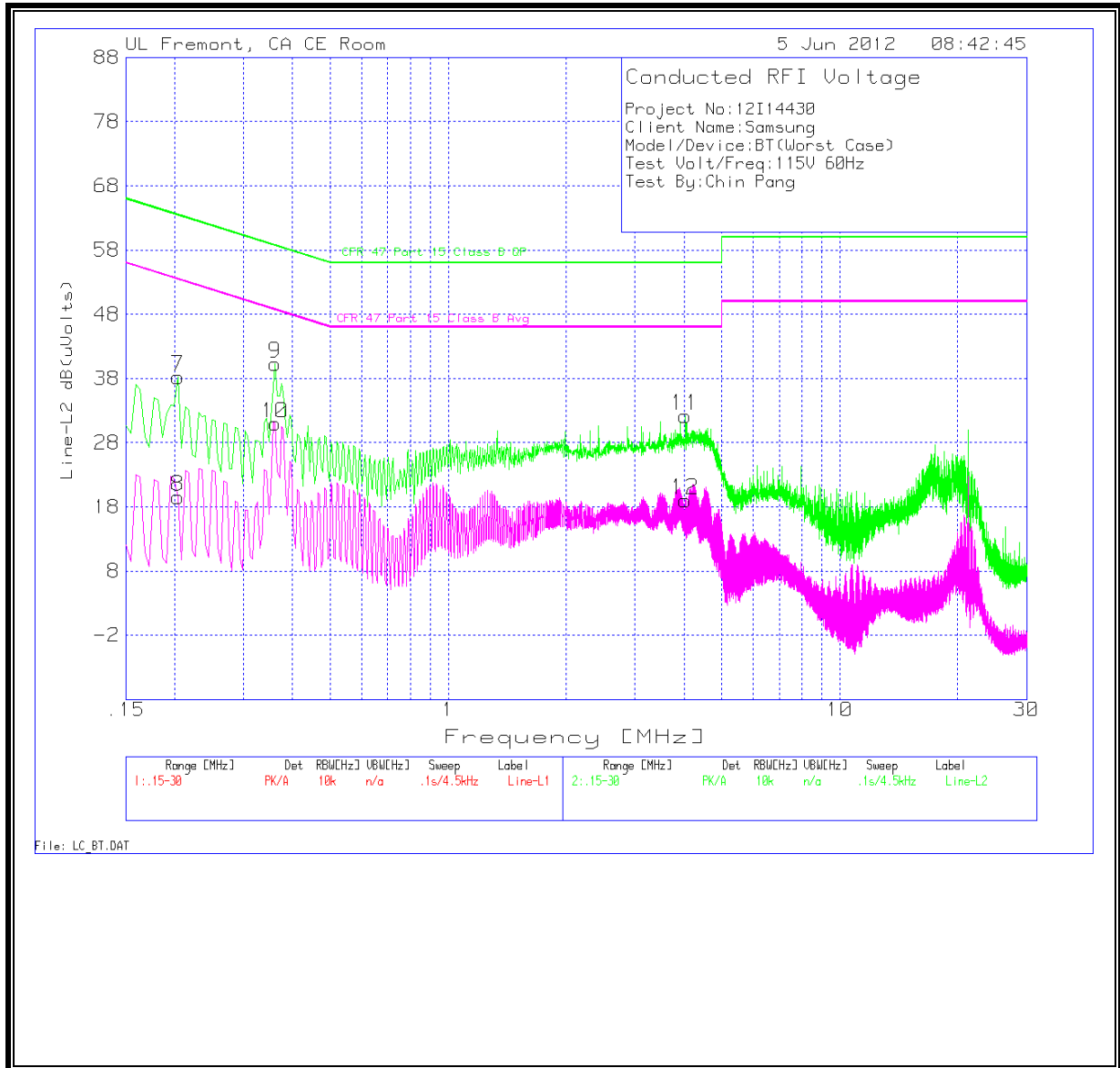

10. MAXIMUM PERMISSIBLE EXPOSURE

FCC RULES

§1.1310 The criteria listed in Table 1 shall be used to evaluate the environmental impact of human exposure to radio-frequency (RF) radiation as specified in §1.1307(b), except in the case of portable devices which shall be evaluated according to the provisions of §2.1093 of this chapter.

TABLE 1—LIMITS FOR MAXIMUM PERMISSIBLE EXPOSURE (MPE)

Frequency range (MHz)	Electric field strength (V/m)	Magnetic field strength (A/m)	Power density (mW/cm ²)	Averaging time (minutes)
(A) Limits for Occupational/Controlled Exposures				
0.3–3.0	614	1.63	*(100)	6
3.0–30	1842/f	4.89/f	*(900/f ²)	6
30–300	61.4	0.163	1.0	6
300–1500	f/300	6
1500–100,000	5	6
(B) Limits for General Population/Uncontrolled Exposure				
0.3–1.34	614	1.63	*(100)	30
1.34–30	824/f	2.19/f	*(180/f ²)	30

TABLE 1—LIMITS FOR MAXIMUM PERMISSIBLE EXPOSURE (MPE)—Continued

Frequency range (MHz)	Electric field strength (V/m)	Magnetic field strength (A/m)	Power density (mW/cm ²)	Averaging time (minutes)
30–300	27.5	0.073	0.2	30
300–1500	f/1500	30
1500–100,000	1.0	30

f = frequency in MHz

* = Plane-wave equivalent power density

NOTE 1 TO TABLE 1: Occupational/controlled limits apply in situations in which persons are exposed as a consequence of their employment provided those persons are fully aware of the potential for exposure and can exercise control over their exposure. Limits for occupational/controlled exposure also apply in situations when an individual is transient through a location where occupational/controlled limits apply provided he or she is made aware of the potential for exposure.

NOTE 2 TO TABLE 1: General population/uncontrolled exposures apply in situations in which the general public may be exposed, or in which persons that are exposed as a consequence of their employment may not be fully aware of the potential for exposure or can not exercise control over their exposure.

IC RULES

IC Safety Code 6, Section 2.2.1 (a) A person other than an RF and microwave exposed worker shall not be exposed to electromagnetic radiation in a frequency band listed in Column 1 of Table 5, if the field strength exceeds the value given in Column 2 or 3 of Table 5, when averaged spatially and over time, or if the power density exceeds the value given in Column 4 of Table 5, when averaged spatially and over time.

**Table 5
 Exposure Limits for Persons Not Classed As RF and Microwave Exposed Workers (Including the General Public)**

1 Frequency (MHz)	2 Electric Field Strength; rms (V/m)	3 Magnetic Field Strength; rms (A/m)	4 Power Density (W/m ²)	5 Averaging Time (min)
0.003–1	280	2.19		6
1–10	280/ <i>f</i>	2.19/ <i>f</i>		6
10–30	28	2.19/ <i>f</i>		6
30–300	28	0.073	2*	6
300–1 500	1.585 <i>f</i> ^{0.5}	0.0042 <i>f</i> ^{0.5}	<i>f</i> /150	6
1 500–15 000	61.4	0.163	10	6
15 000–150 000	61.4	0.163	10	616 000 / <i>f</i> ^{1.2}
150 000–300 000	0.158 <i>f</i> ^{0.5}	4.21 x 10 ⁻⁴ <i>f</i> ^{0.5}	6.67 x 10 ⁻⁵ <i>f</i>	616 000 / <i>f</i> ^{1.2}

* Power density limit is applicable at frequencies greater than 100 MHz.

- Notes:**
1. Frequency, *f*, is in MHz.
 2. A power density of 10 W/m² is equivalent to 1 mW/cm².
 3. A magnetic field strength of 1 A/m corresponds to 1.257 microtesla (μT) or 12.57 milligauss (mG).

EQUATIONS

Power density is given by:

$$S = \text{EIRP} / (4 * \text{Pi} * \text{D}^2)$$

where

S = Power density in W/m²

EIRP = Equivalent Isotropic Radiated Power in W

D = Separation distance in m

Power density in units of W/m² is converted to units of mW/cm² by dividing by 10.

Distance is given by:

$$D = \text{SQRT} (\text{EIRP} / (4 * \text{Pi} * S))$$

where

D = Separation distance in m

EIRP = Equivalent Isotropic Radiated Power in W

S = Power density in W/m²

For multiple colocated transmitters operating simultaneously in frequency bands where the limit is identical, the total power density is calculated using the total EIRP obtained by summing the Power * Gain product (in linear units) of each transmitter.

$$\text{Total EIRP} = (P1 * G1) + (P2 * G2) + \dots + (Pn * Gn)$$

where

Px = Power of transmitter x

Gx = Numeric gain of antenna x

In the table(s) below, Power and Gain are entered in units of dBm and dBi respectively and conversions to linear forms are used for the calculations.

LIMITS

From FCC §1.1310 Table 1 (B), the maximum value of S = 1.0 mW/cm²

RESULTS

Band	Mode	Separation Distance (m)	Output AV Power (dBm)	Antenna Gain (dBi)	IC Power Density (W/m ²)	FCC Power Density (mW/cm ²)
2.4 GHz	Bluetooth	0.20	10.00	-0.70	0.017	0.0017