

Antenna-2 Power Spectral Density Measurements (40MHz BW)

Frequency [MHz]	Channel No.	802.11 Mode	Data Rate [Mbps]	Measured Power Spectral Density [dBm]	Maximum Permissible Power Density [dBm / 3kHz]	Margin [dB]	Pass / Fail
2422	3	n/ac	162/180 (MCS8)	-8.53	8.00	-16.53	Pass
2437	6	n/ac	162/180 (MCS8)	-8.68	8.00	-16.68	Pass
2457	10	n/ac	162/180 (MCS8)	-8.34	8.00	-16.34	Pass

Table 7-20. Conducted Power Density Measurements

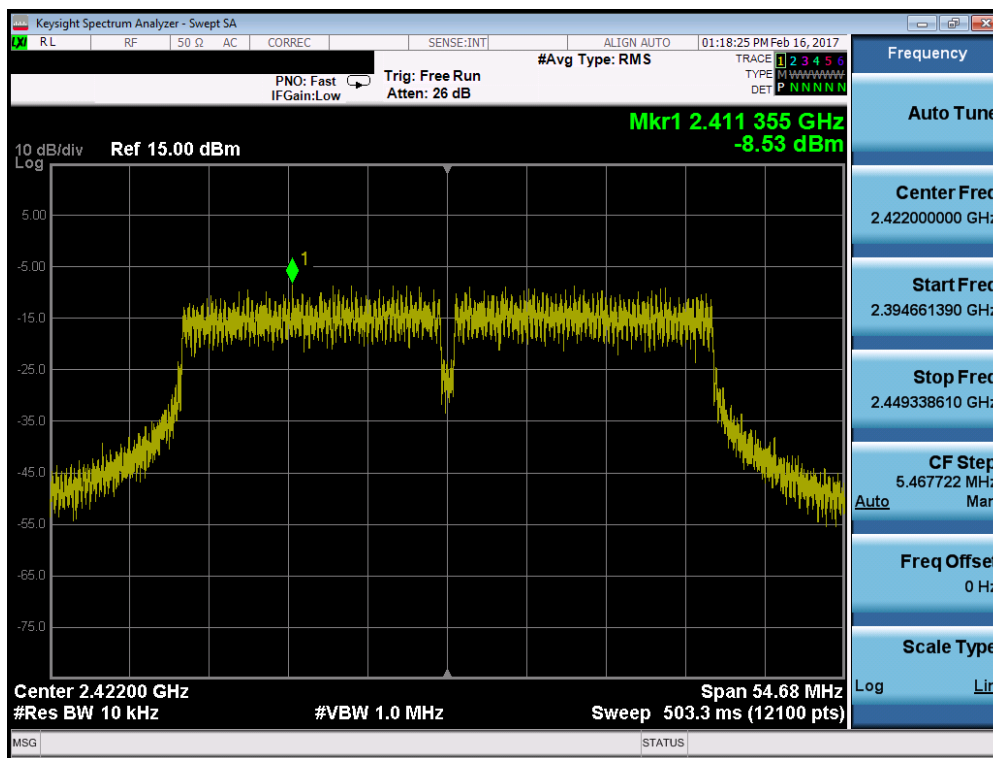

Plot 7-88. Power Spectral Density Plot (40MHz 802.11ac – Ch. 3)

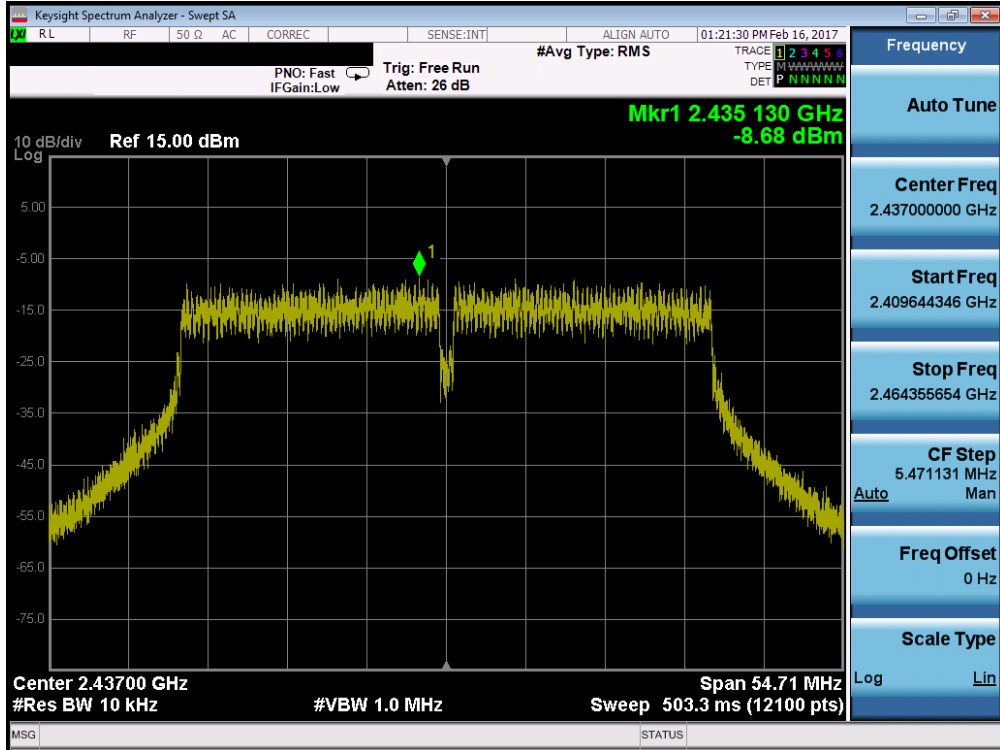

FCC ID: A3LETWV531		FCC Pt. 15.247 802.11b/g/n/ac MEASUREMENT REPORT (CERTIFICATION)		Approved by: Quality Manager
Test Report S/N: 1M1705180171-02.A3L	Test Dates: 11/23/2016-02/17/2017	EUT Type: Indoor Access Point		Page 70 of 196

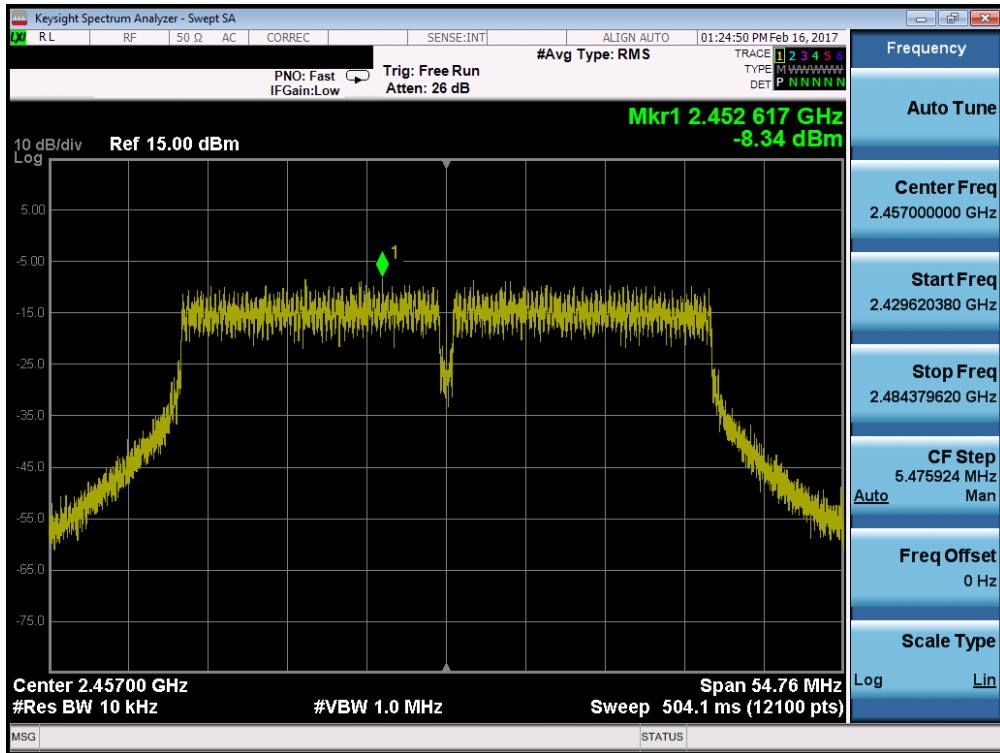

Plot 7-89. Power Spectral Density Plot (40MHz 802.11ac – Ch. 6)



Plot 7-90. Power Spectral Density Plot (802.11n (2.4GHz) – Ch. 10)

FCC ID: A3LETWV531		FCC Pt. 15.247 802.11b/g/n/ac MEASUREMENT REPORT (CERTIFICATION)		Approved by: Quality Manager
Test Report S/N: 1M1705180171-02.A3L	Test Dates: 11/23/2016-02/17/2017	EUT Type: Indoor Access Point		Page 71 of 196

Antenna-3 Power Spectral Density Measurements (40MHz BW)

Frequency [MHz]	Channel No.	802.11 Mode	Data Rate [Mbps]	Measured Power Spectral Density [dBm]	Maximum Permissible Power Density [dBm / 3kHz]	Margin [dB]	Pass / Fail
2422	3	n/ac	162/180 (MCS8)	-7.84	8.00	-15.84	Pass
2437	6	n/ac	162/180 (MCS8)	-8.52	8.00	-16.52	Pass
2457	10	n/ac	162/180 (MCS8)	-8.14	8.00	-16.14	Pass

Table 7-21. Conducted Power Density Measurements

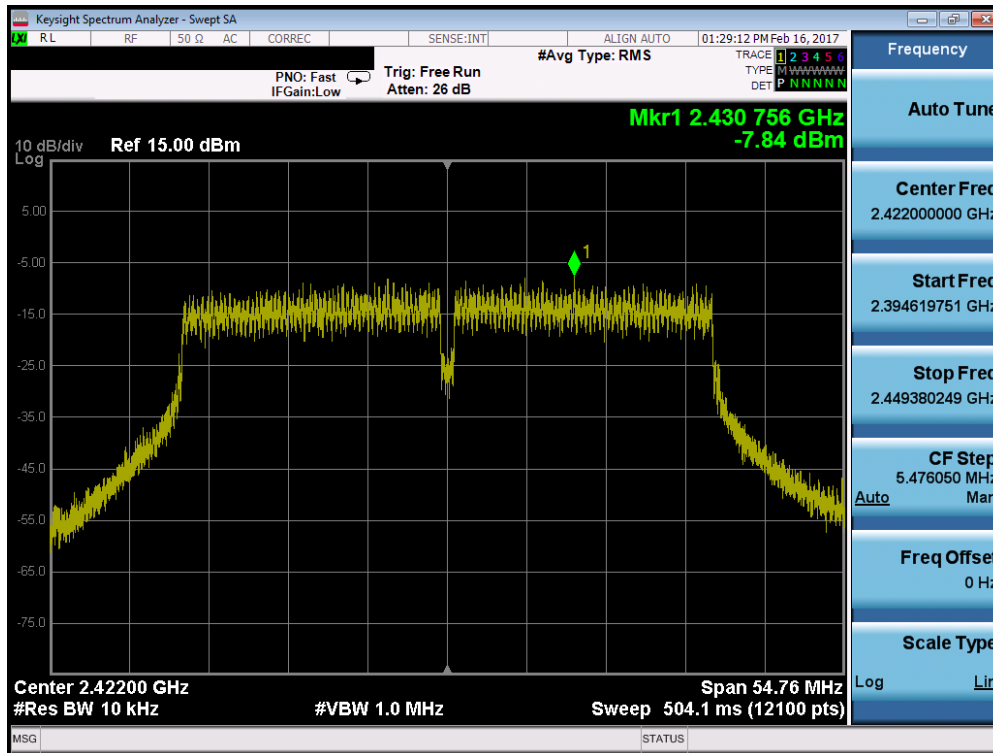

Plot 7-91. Power Spectral Density Plot (40MHz 802.11ac – Ch. 3)

FCC ID: A3LETWV531		FCC Pt. 15.247 802.11b/g/n/ac MEASUREMENT REPORT (CERTIFICATION)		Approved by: Quality Manager
Test Report S/N: 1M1705180171-02.A3L	Test Dates: 11/23/2016-02/17/2017	EUT Type: Indoor Access Point		Page 72 of 196

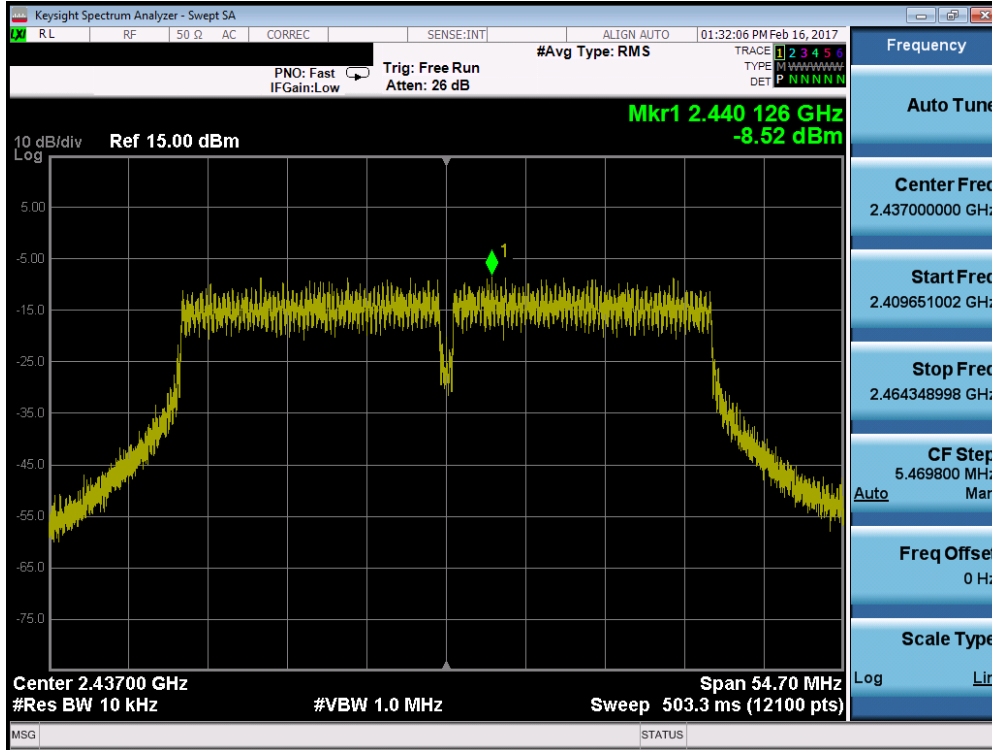

Plot 7-92. Power Spectral Density Plot (40MHz 802.11ac – Ch. 6)

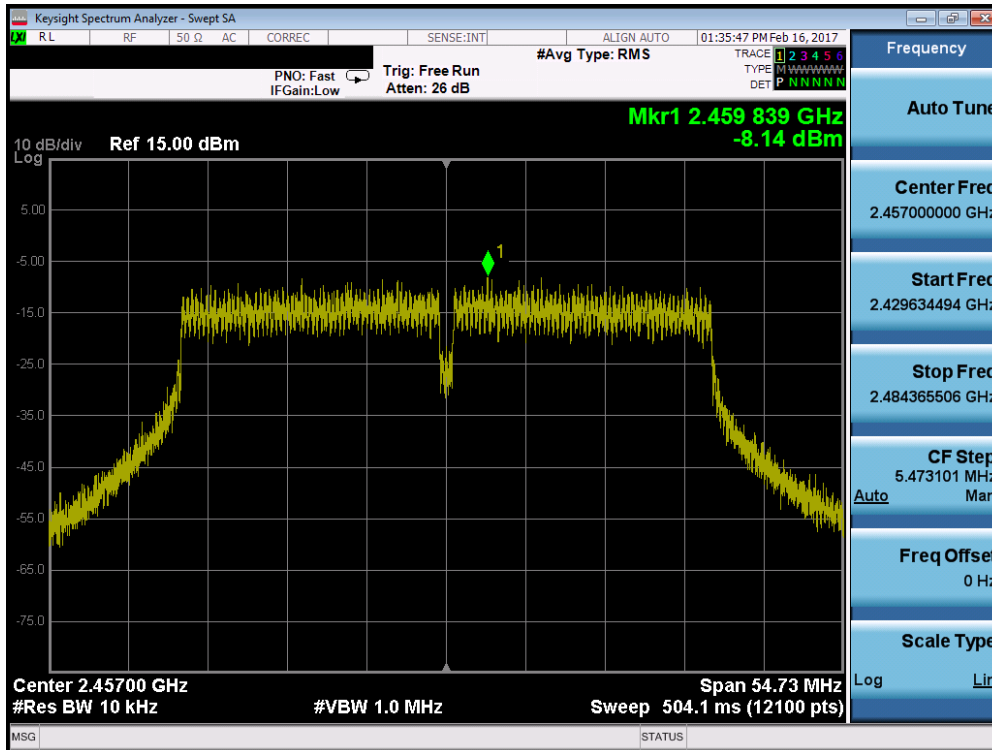

Plot 7-93. Power Spectral Density Plot (802.11n (2.4GHz) – Ch. 10)

FCC ID: A3LETWV531		FCC Pt. 15.247 802.11b/g/n/ac MEASUREMENT REPORT (CERTIFICATION)		Approved by: Quality Manager
Test Report S/N: 1M1705180171-02.A3L	Test Dates: 11/23/2016-02/17/2017	EUT Type: Indoor Access Point		Page 73 of 196

Antenna-4 Power Spectral Density Measurements (40MHz BW)

Frequency [MHz]	Channel No.	802.11 Mode	Data Rate [Mbps]	Measured Power Spectral Density [dBm]	Maximum Permissible Power Density [dBm / 3kHz]	Margin [dB]	Pass / Fail
2422	3	n/ac	162/180 (MCS8)	-8.44	8.00	-16.44	Pass
2437	6	n/ac	162/180 (MCS8)	-8.00	8.00	-16.00	Pass
2457	10	n/ac	162/180 (MCS8)	-8.05	8.00	-16.05	Pass

Table 7-22. Conducted Power Density Measurements

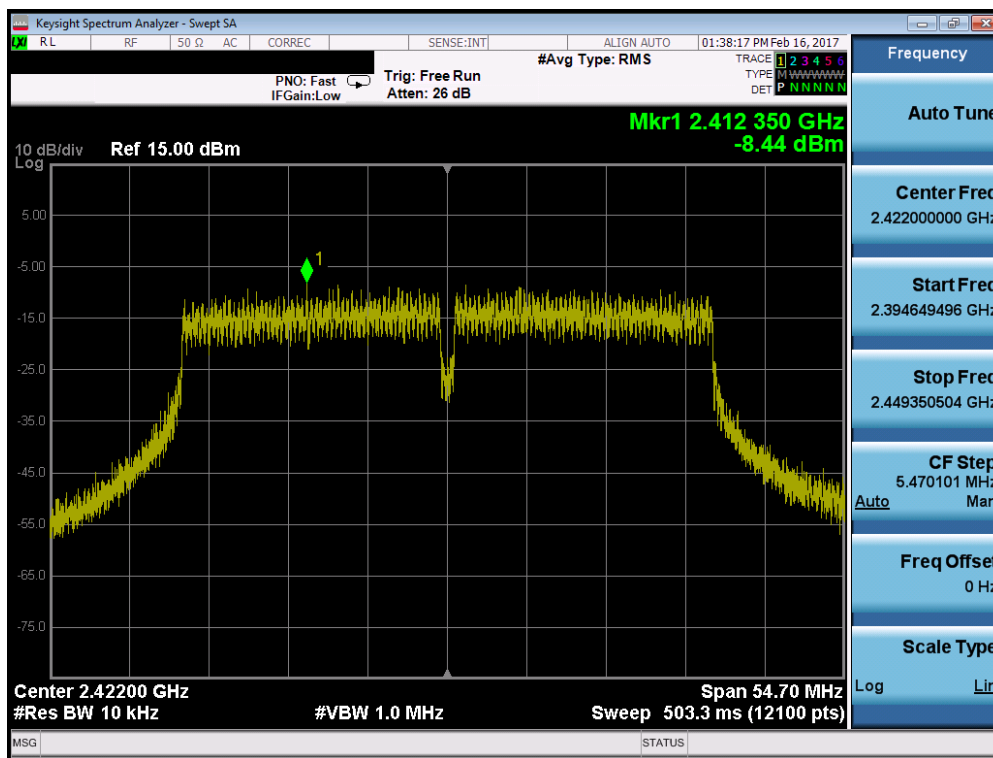

Plot 7-94. Power Spectral Density Plot (40MHz 802.11ac – Ch. 3)

FCC ID: A3LETWV531		FCC Pt. 15.247 802.11b/g/n/ac MEASUREMENT REPORT (CERTIFICATION)		Approved by: Quality Manager
Test Report S/N: 1M1705180171-02.A3L	Test Dates: 11/23/2016-02/17/2017	EUT Type: Indoor Access Point	Page 74 of 196	

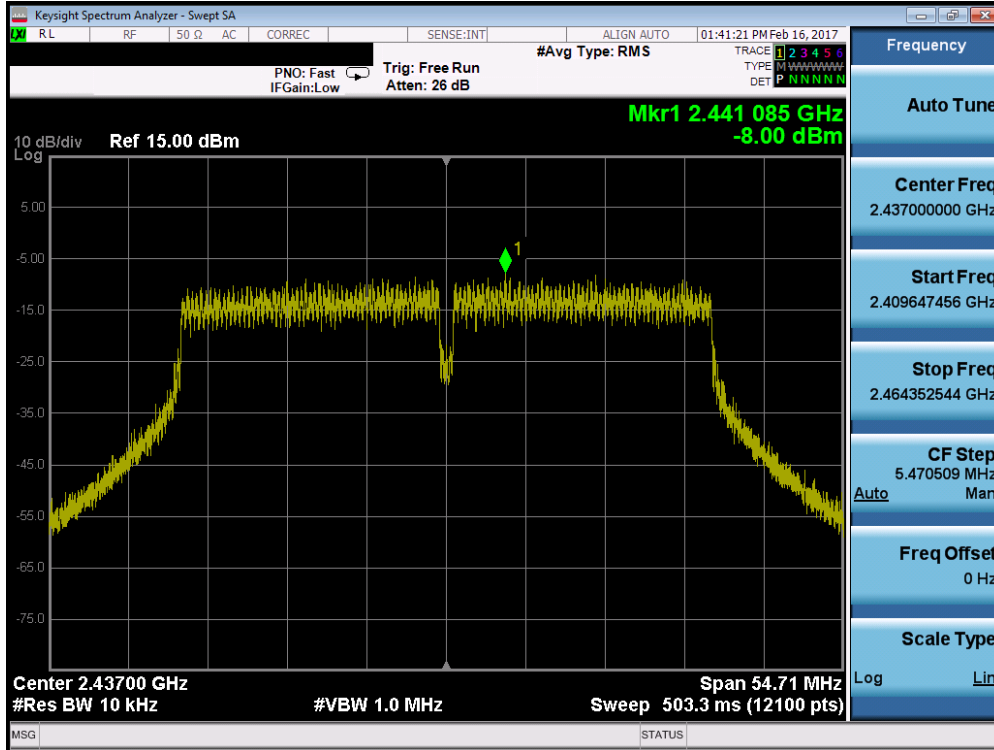

Plot 7-95. Power Spectral Density Plot (40MHz 802.11ac – Ch. 6)

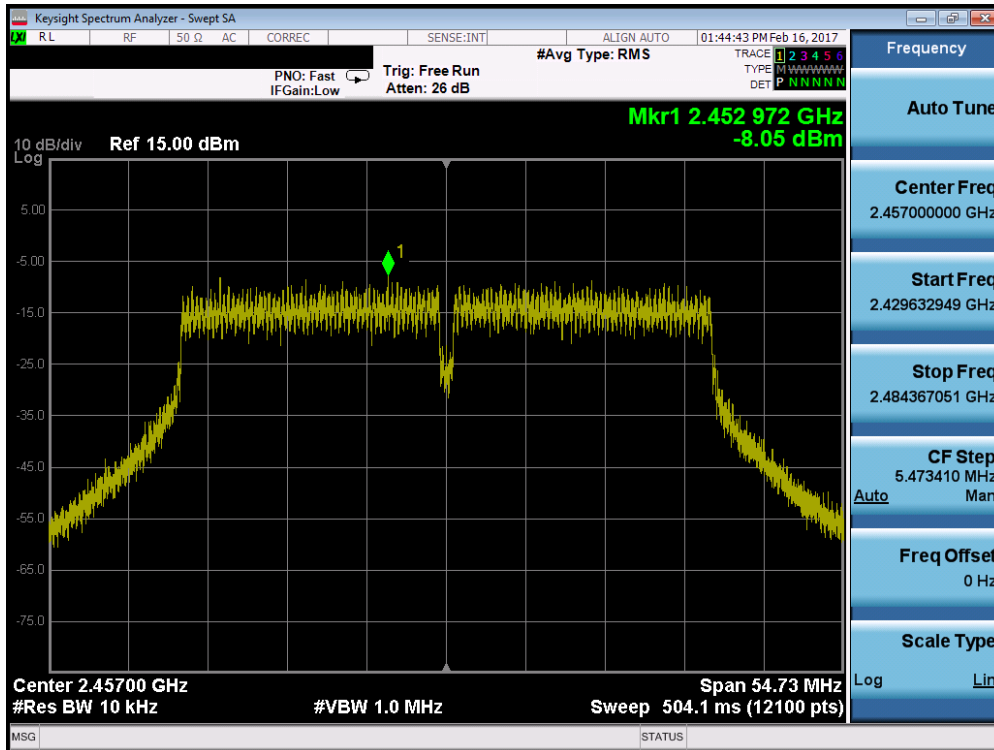

Plot 7-96. Power Spectral Density Plot (802.11n (2.4GHz) – Ch. 10)

FCC ID: A3LETWV531		FCC Pt. 15.247 802.11b/g/n/ac MEASUREMENT REPORT (CERTIFICATION)		Approved by: Quality Manager
Test Report S/N: 1M1705180171-02.A3L	Test Dates: 11/23/2016-02/17/2017	EUT Type: Indoor Access Point		Page 75 of 196

MIMO Power Spectral Density Measurements

Frequency [MHz]	Channel No.	802.11 Mode	Data Rate [Mbps]	Directional Gain [dBi]	ANT 1 Power Spectral Density [dBm]	ANT 2 Power Spectral Density [dBm]	ANT 3 Power Spectral Density [dBm]	ANT 4 Power Spectral Density [dBm]	Summed MIMO Power Spectral Density [dBm]	Maximum Permissible Power Density [dBm / 3kHz]	Adjusted Limit	Margin [dB]	Pass / Fail
2412	1	n	6.5/7.2 (MCS0)	7.83	-0.51	-1.78	-0.11	-0.64	5.30	8.00	6.17	-0.87	Pass
2437	6	n	6.5/7.2 (MCS0)	7.68	-0.84	-2.10	-0.86	-1.89	4.64	8.00	6.32	-1.68	Pass
2462	11	n	6.5/7.2 (MCS0)	7.32	-0.80	-2.83	-0.80	-0.56	4.86	8.00	6.68	-1.82	Pass

Table 7-23. 802.11n (20MHz BW) MIMO Conducted Power Density Measurements

Frequency [MHz]	Channel No.	802.11 Mode	Data Rate [Mbps]	Directional Gain [dBi]	ANT 1 Power Spectral Density [dBm]	ANT 2 Power Spectral Density [dBm]	ANT 3 Power Spectral Density [dBm]	ANT 4 Power Spectral Density [dBm]	Summed MIMO Power Spectral Density [dBm]	Maximum Permissible Power Density [dBm / 3kHz]	Adjusted Limit	Margin [dB]	Pass / Fail
2422	3	n/ac	6.5/7.2 (MCS0)	7.83	-8.29	-8.53	-7.84	-8.44	-2.25	8.00	6.17	-8.42	Pass
2437	6	n/ac	6.5/7.2 (MCS0)	7.68	-9.28	-8.68	-8.52	-8.00	-2.58	8.00	6.32	-8.90	Pass
2457	10	n/ac	6.5/7.2 (MCS0)	7.68	-8.34	-8.34	-8.14	-8.05	-2.20	8.00	6.32	-8.52	Pass

Table 7-24.802.11n/ac (40MHz BW) MIMO Conducted Power Density Measurements

Note:



Per KDB 662911 D01 v02r01 Section E)2), the power spectral density at the four antennas were first measured separately as shown in the section above. The measured values were then summed in linear power units then converted back to dBm.

Sample MIMO Calculation:

At 2412MHz the average conducted power spectral density was measured to be -0.51 dBm for Antenna-1, -1.78 dBm for Antenna-2, -0.11 dBm for Antenna-3 and -0.64 dBm for Antenna-4.

$$\text{Antenna 1} + \text{Antenna 2} + \text{Antenna 3} + \text{Antenna 4} = \text{MIMO}$$

$$(-0.51 \text{ dBm} + -1.78 \text{ dBm} + -0.11 \text{ dBm} + -0.64 \text{ dBm}) = (0.89 \text{ mW} + 0.66 \text{ mW} + 0.97 \text{ mW} + 0.86 \text{ mW}) = 3.38 \text{ mW} = 5.30 \text{ dBm}$$

FCC ID: A3LETWV531		FCC Pt. 15.247 802.11b/g/n/ac MEASUREMENT REPORT (CERTIFICATION)		Approved by: Quality Manager
Test Report S/N: 1M1705180171-02.A3L	Test Dates: 11/23/2016-02/17/2017	EUT Type: Indoor Access Point	Page 76 of 196	

7.5 Conducted Emissions at the Band Edge §15.247(d)

Test Overview and Limit

All out of band emissions are measured with a spectrum analyzer connected to the antenna terminal of the EUT while the EUT is operating at its maximum duty cycle, at maximum power, and at the appropriate frequencies. All data rates were investigated to determine the worst case configuration. For the following out of band conducted spurious emissions plots at the band edge, the EUT was set at a data rate of 1Mbps for “b” mode, 6 Mbps for “g” mode, and 6.5/7.2Mbps for “n” mode as these settings produced the worst-case emissions.

The limit for out-of-band spurious emissions at the band edge is 30dB below the fundamental emission level, as determined from the in-band power measurement of the DTS channel performed in a 100kHz bandwidth per the PSD procedure (Section 7.4).

Test Procedure Used

KDB 558074 D01 v04 – Section 11.3

Test Settings

1. Start and stop frequency were set such that the band edge would be placed in the center of the plot
2. Span was set large enough so as to capture all out of band emissions near the band edge
3. RBW = 100kHz
4. VBW = 1MHz
5. Detector = Peak
6. Number of sweep points $\geq 2 \times \text{Span/RBW}$
7. Trace mode = max hold
8. Sweep time = auto couple
9. The trace was allowed to stabilize

Test Setup

The EUT and measurement equipment were set up as shown in the diagram below.

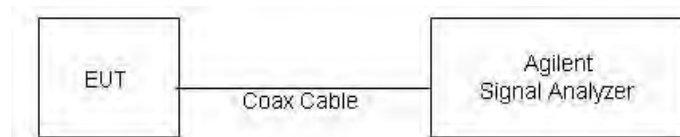



Figure 7-4. Test Instrument & Measurement Setup

Test Notes

None

FCC ID: A3LETWV531		FCC Pt. 15.247 802.11b/g/n/ac MEASUREMENT REPORT (CERTIFICATION)		Approved by: Quality Manager
Test Report S/N: 1M1705180171-02.A3L	Test Dates: 11/23/2016-02/17/2017	EUT Type: Indoor Access Point	Page 77 of 196	

Antenna-1 Conducted Emissions at the Band Edge

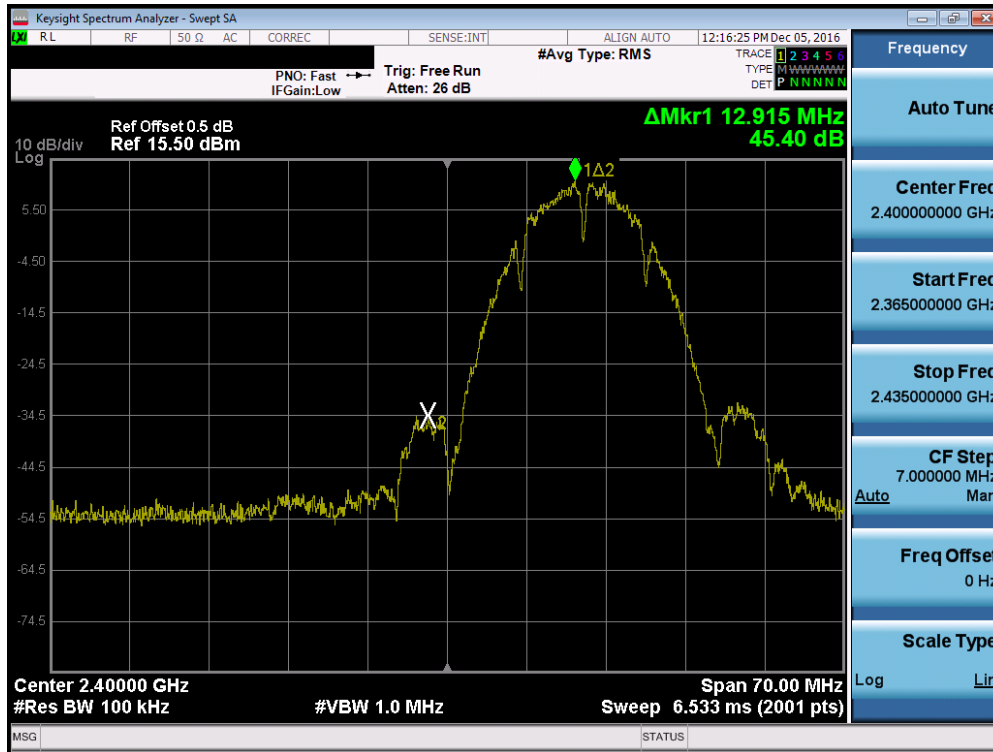

Plot 7-97. Band Edge Plot (802.11b – Ch. 1)

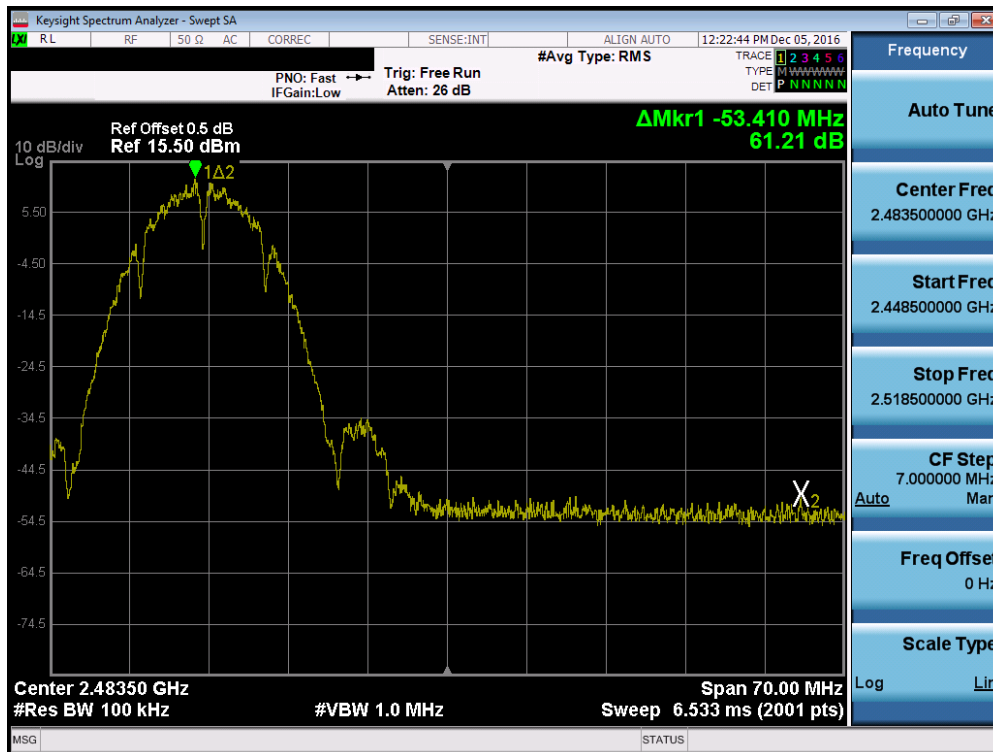

Plot 7-98. Band Edge Plot (802.11b – Ch. 1)

FCC ID: A3LETWV531		FCC Pt. 15.247 802.11b/g/n/ac MEASUREMENT REPORT (CERTIFICATION)		Approved by: Quality Manager
Test Report S/N: 1M1705180171-02.A3L	Test Dates: 11/23/2016-02/17/2017	EUT Type: Indoor Access Point		Page 78 of 196

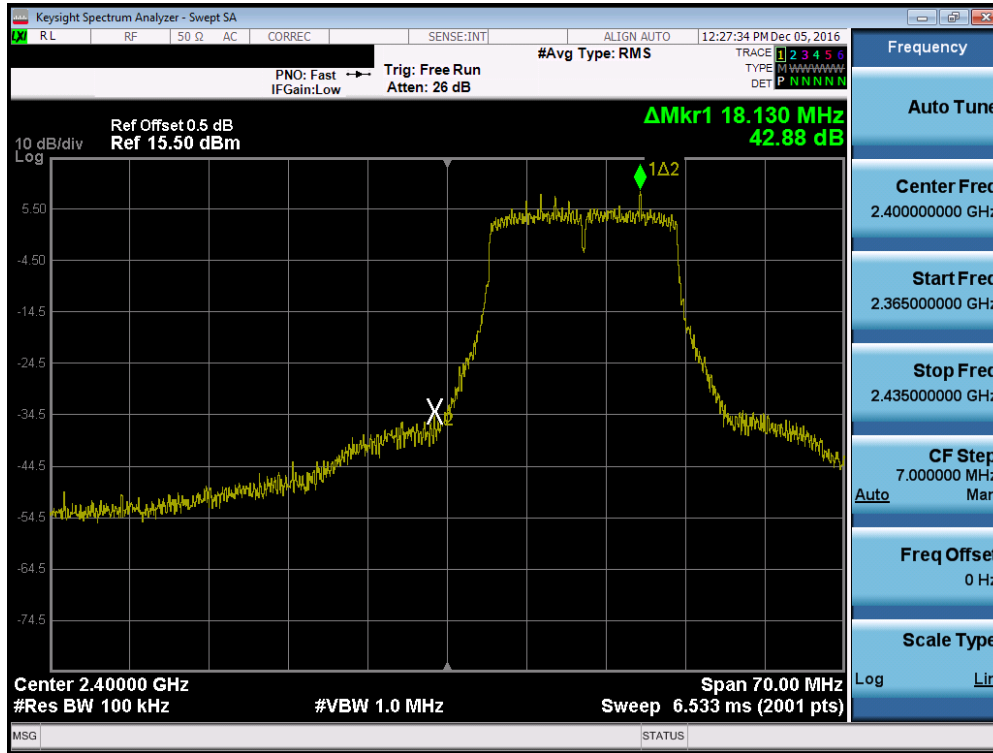

Plot 7-99. Band Edge Plot (802.11g- Ch. 1)

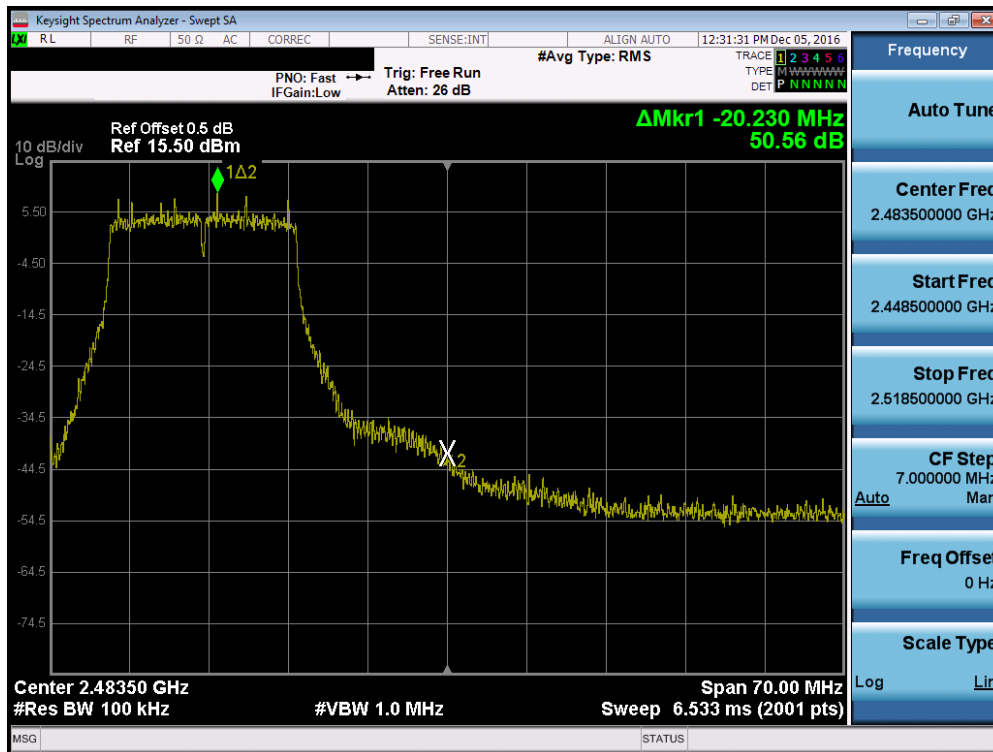

Plot 7-100. Band Edge Plot (802.11g - Ch. 11)

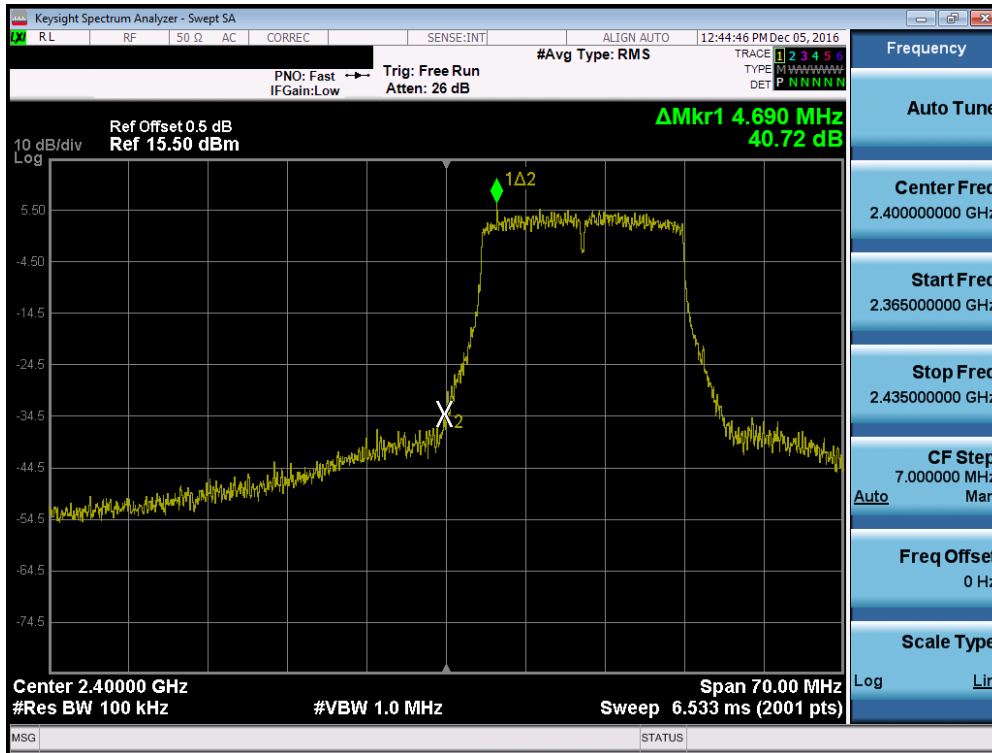

FCC ID: A3LETWV531		FCC Pt. 15.247 802.11b/g/n/ac MEASUREMENT REPORT (CERTIFICATION)		Approved by: Quality Manager
Test Report S/N: 1M1705180171-02.A3L	Test Dates: 11/23/2016-02/17/2017	EUT Type: Indoor Access Point		Page 79 of 196

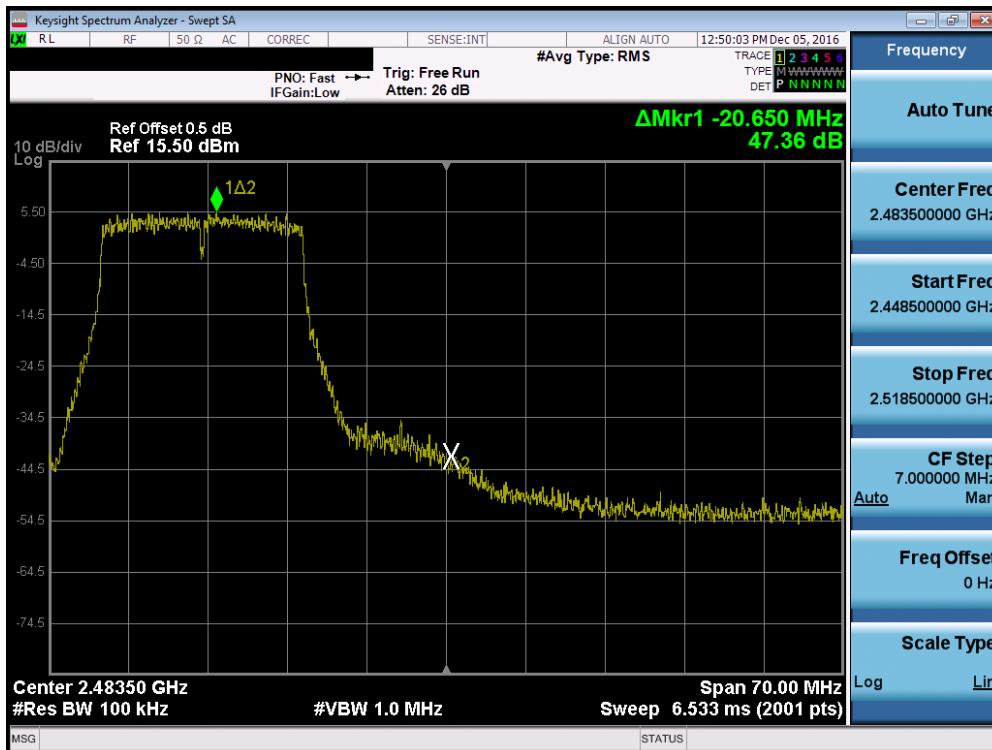

Plot 7-101. Band Edge Plot (802.11n (2.4GHz) – Ch. 1)



Plot 7-102. Band Edge Plot (802.11n (2.4GHz) – Ch. 11)

FCC ID: A3LETWV531		FCC Pt. 15.247 802.11b/g/n/ac MEASUREMENT REPORT (CERTIFICATION)		Approved by: Quality Manager
Test Report S/N: 1M1705180171-02.A3L	Test Dates: 11/23/2016-02/17/2017	EUT Type: Indoor Access Point		Page 80 of 196

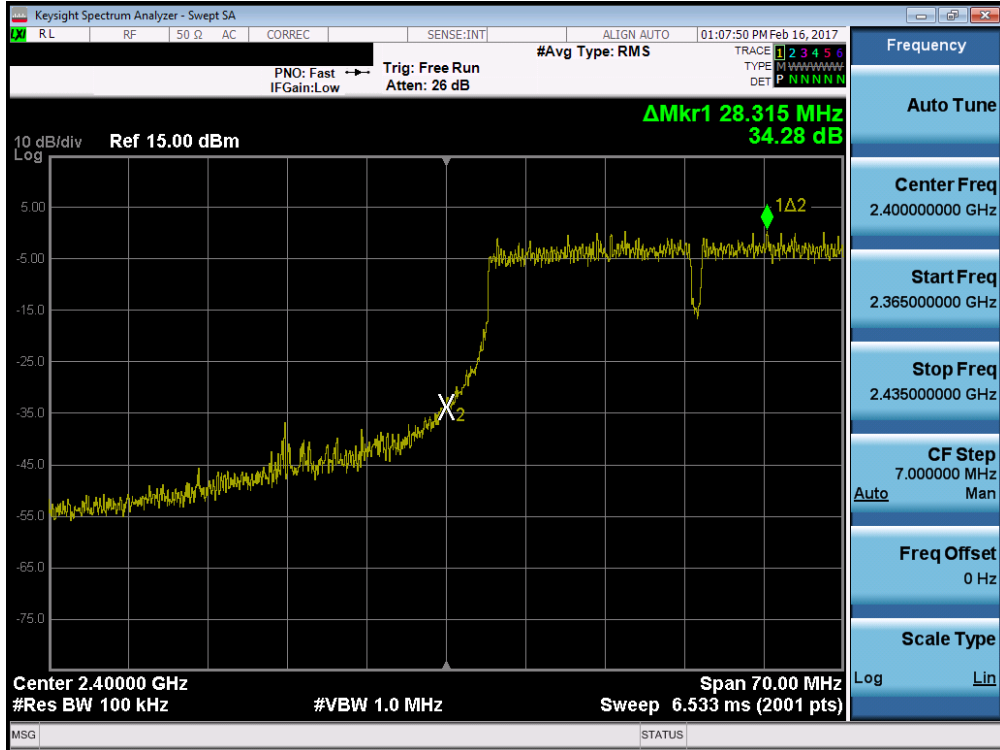

Plot 7-103. Band Edge Plot (40MHz 802.11n/ac – Ch. 3)

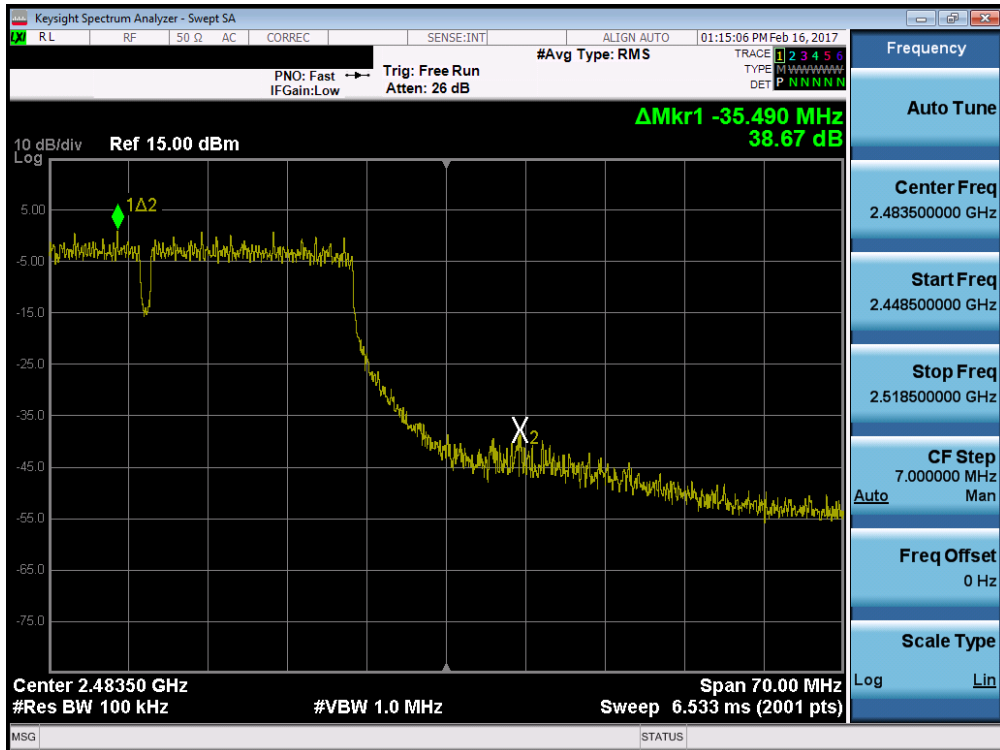

Plot 7-104. Band Edge Plot (40MHz 802.11n/ac – Ch. 10)

FCC ID: A3LETWV531		FCC Pt. 15.247 802.11b/g/n/ac MEASUREMENT REPORT (CERTIFICATION)		Approved by: Quality Manager
Test Report S/N: 1M1705180171-02.A3L	Test Dates: 11/23/2016-02/17/2017	EUT Type: Indoor Access Point		Page 81 of 196

Antenna-2 Conducted Emissions at the Band Edge

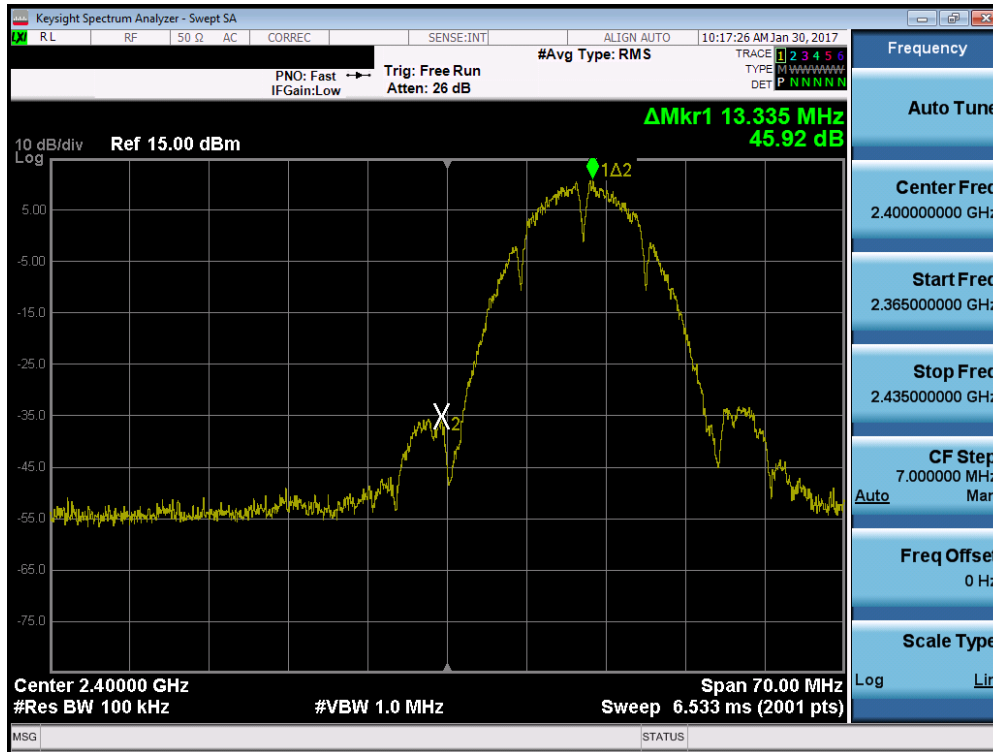

Plot 7-105. Band Edge Plot (802.11b – Ch. 1)

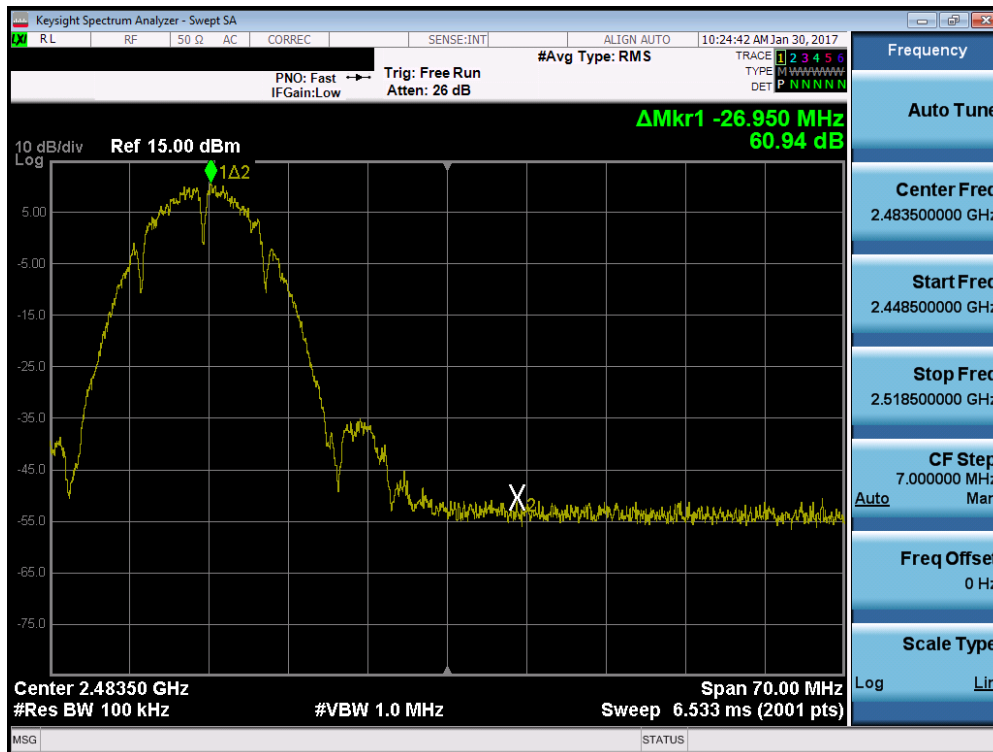

Plot 7-106. Band Edge Plot (802.11b – Ch. 11)

FCC ID: A3LETWV531		FCC Pt. 15.247 802.11b/g/n/ac MEASUREMENT REPORT (CERTIFICATION)		Approved by: Quality Manager
Test Report S/N: 1M1705180171-02.A3L	Test Dates: 11/23/2016-02/17/2017	EUT Type: Indoor Access Point		Page 82 of 196

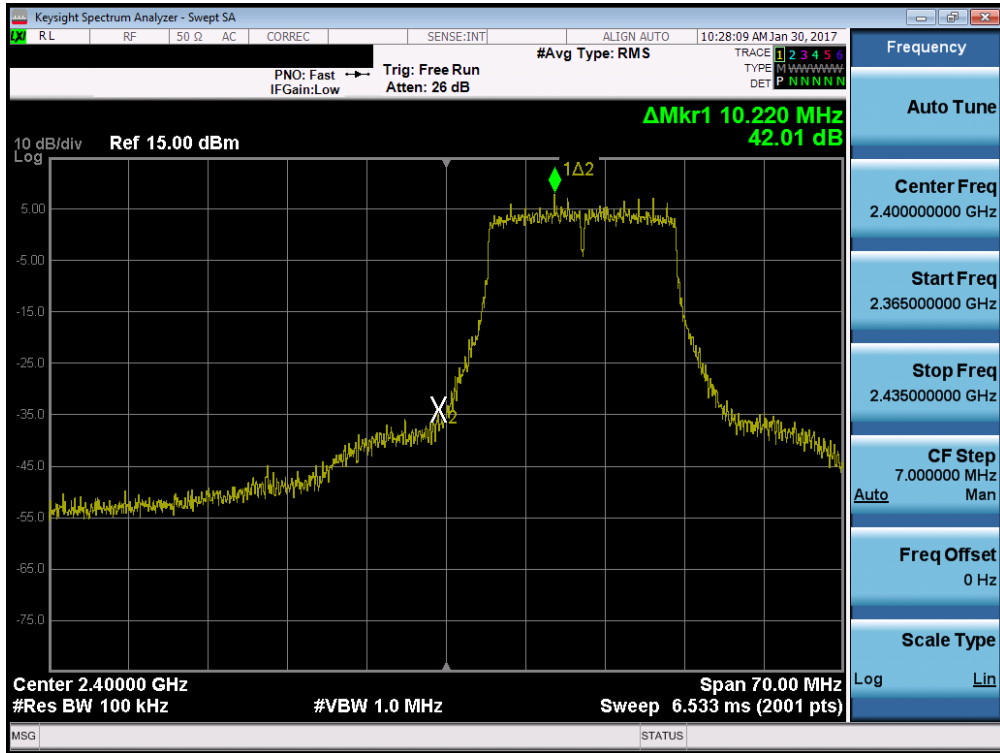

Plot 7-107. Band Edge Plot (802.11g– Ch. 1)

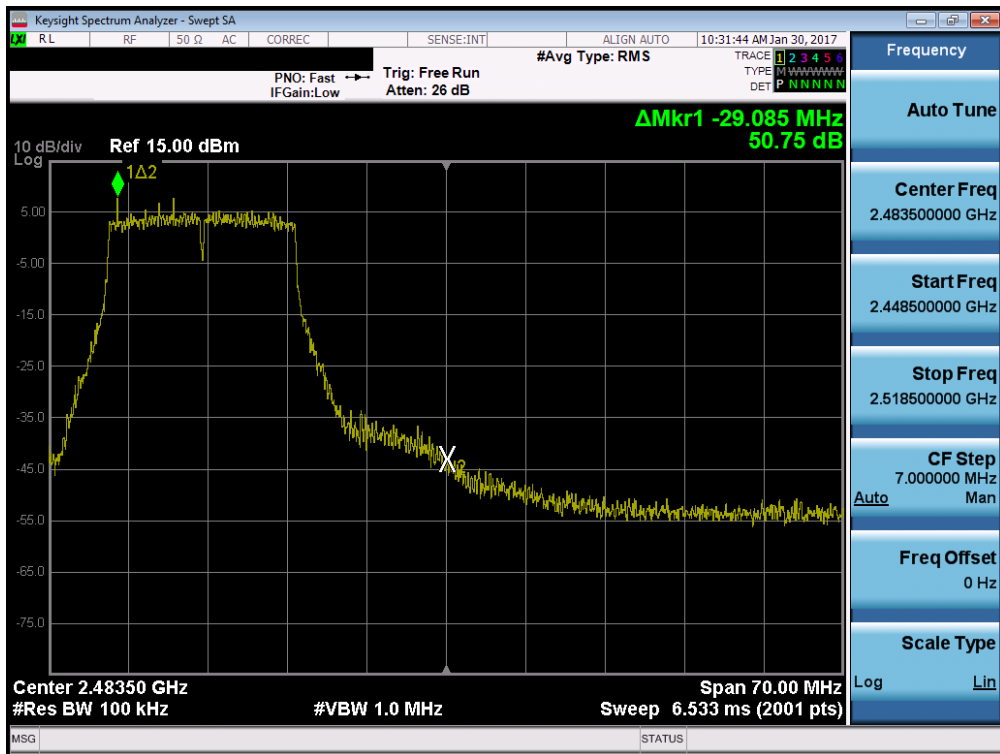

Plot 7-108. Band Edge Plot (802.11g – Ch. 11)

FCC ID: A3LETWV531		FCC Pt. 15.247 802.11b/g/n/ac MEASUREMENT REPORT (CERTIFICATION)		Approved by: Quality Manager
Test Report S/N: 1M1705180171-02.A3L	Test Dates: 11/23/2016-02/17/2017	EUT Type: Indoor Access Point		Page 83 of 196

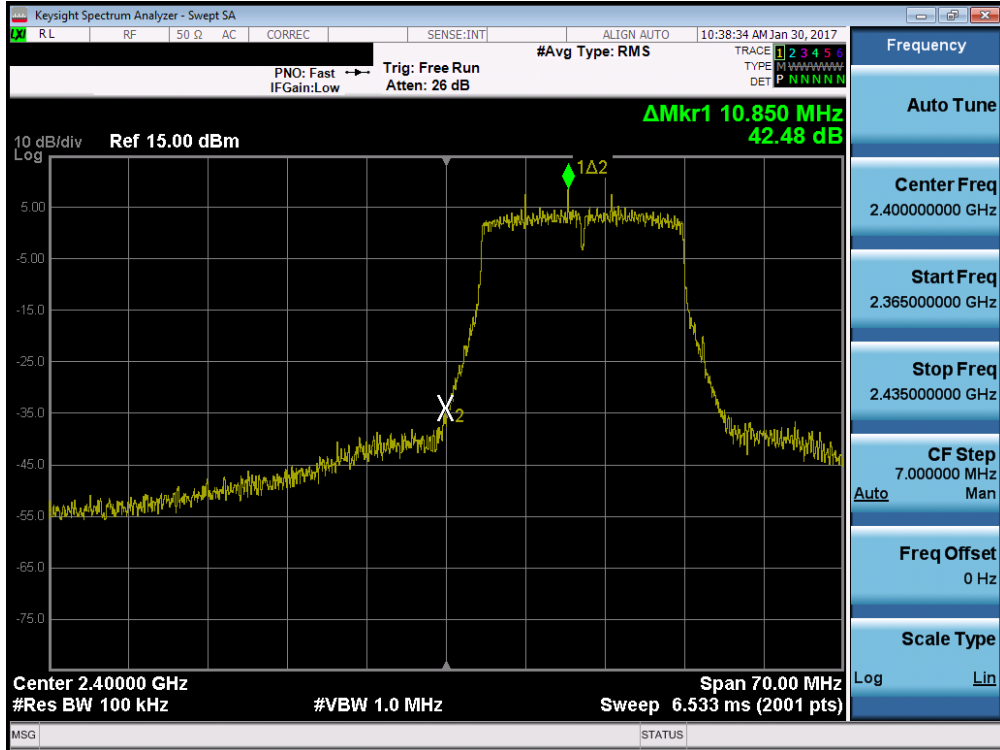

Plot 7-109. Band Edge Plot (802.11n (2.4GHz) – Ch. 1)

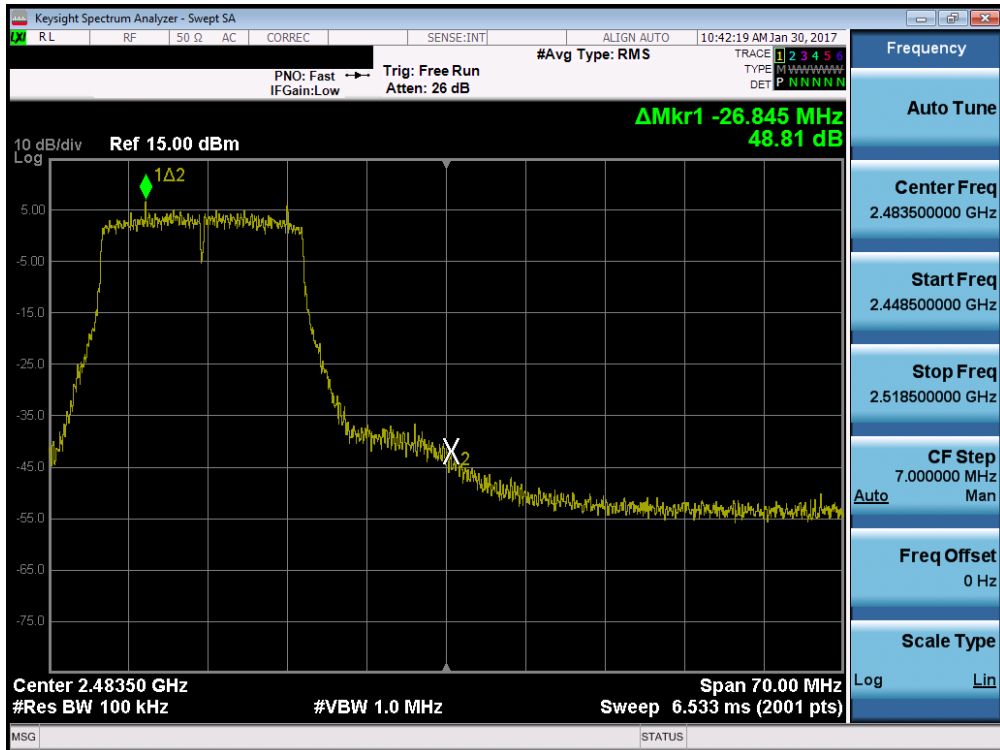

Plot 7-110. Band Edge Plot (802.11n (2.4GHz) – Ch. 11)

FCC ID: A3LETWV531		FCC Pt. 15.247 802.11b/g/n/ac MEASUREMENT REPORT (CERTIFICATION)		Approved by: Quality Manager
Test Report S/N: 1M1705180171-02.A3L	Test Dates: 11/23/2016-02/17/2017	EUT Type: Indoor Access Point		Page 84 of 196

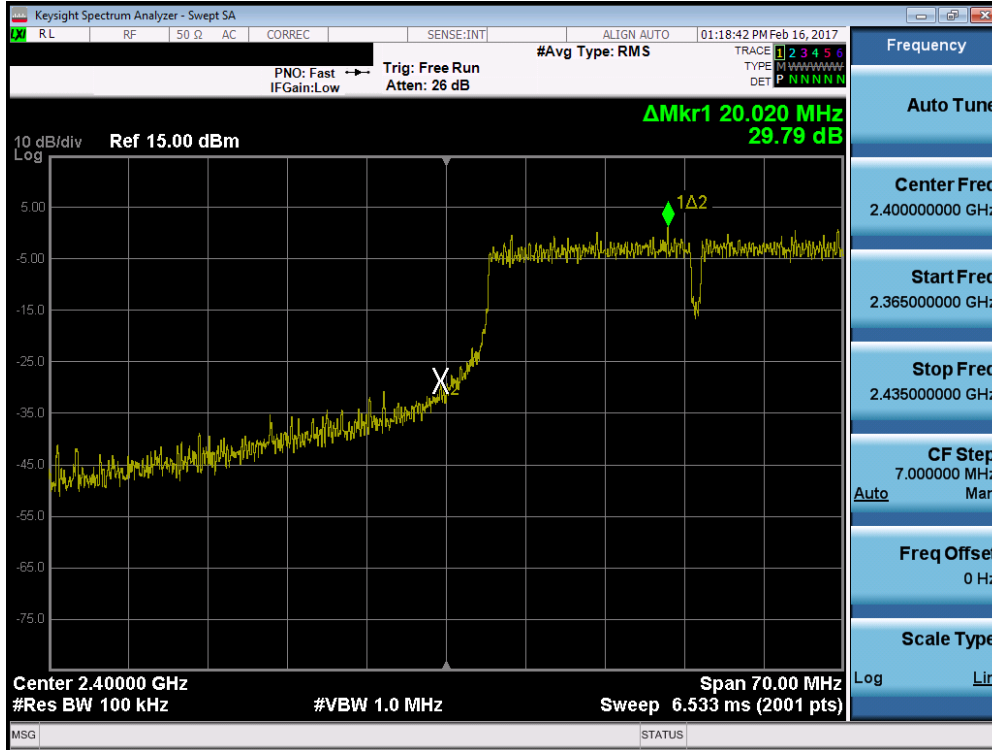

Plot 7-111. Band Edge Plot (40MHz 802.11n/ac – Ch. 3)

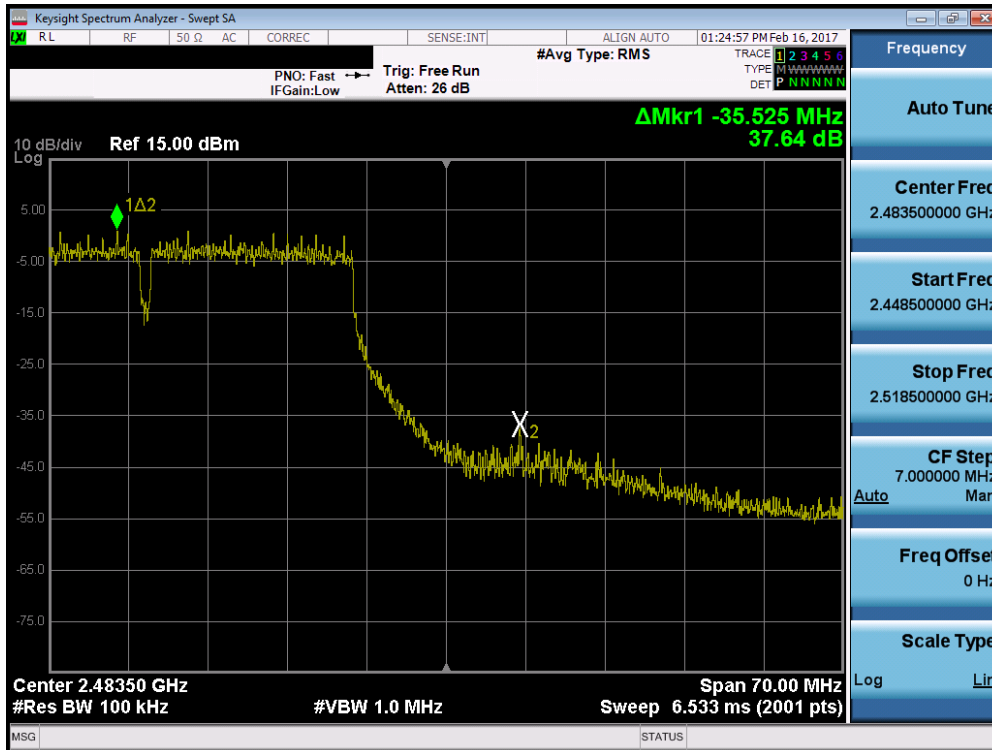

Plot 7-112. Band Edge Plot (40MHz 802.11n/ac – Ch. 10)

FCC ID: A3LETWV531		FCC Pt. 15.247 802.11b/g/n/ac MEASUREMENT REPORT (CERTIFICATION)		Approved by: Quality Manager
Test Report S/N: 1M1705180171-02.A3L	Test Dates: 11/23/2016-02/17/2017	EUT Type: Indoor Access Point		Page 85 of 196

Antenna-3 Conducted Emissions at the Band Edge

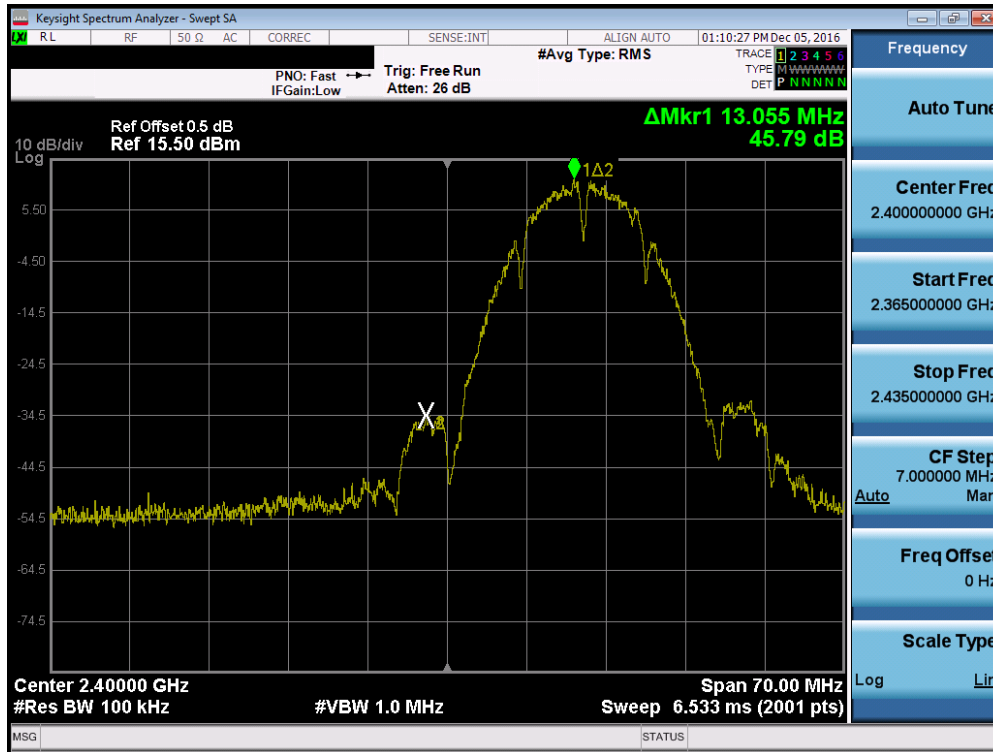

Plot 7-113. Band Edge Plot (802.11b – Ch. 1)

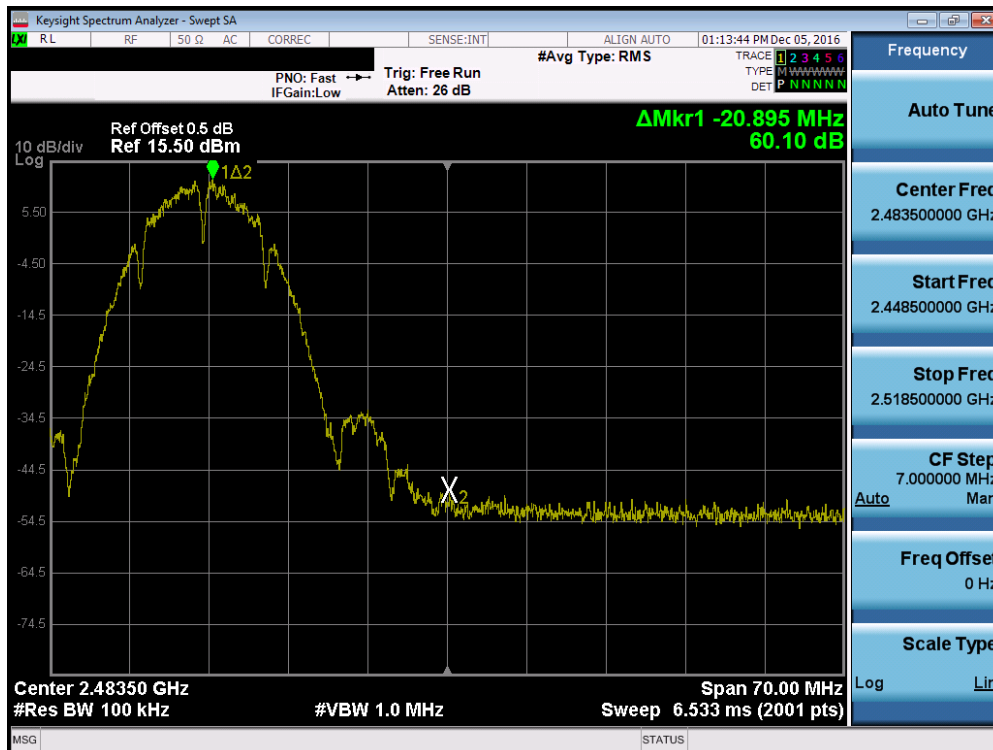

Plot 7-114. Band Edge Plot (802.11b – Ch. 11)

FCC ID: A3LETWV531		FCC Pt. 15.247 802.11b/g/n/ac MEASUREMENT REPORT (CERTIFICATION)		Approved by: Quality Manager
Test Report S/N: 1M1705180171-02.A3L	Test Dates: 11/23/2016-02/17/2017	EUT Type: Indoor Access Point		Page 86 of 196

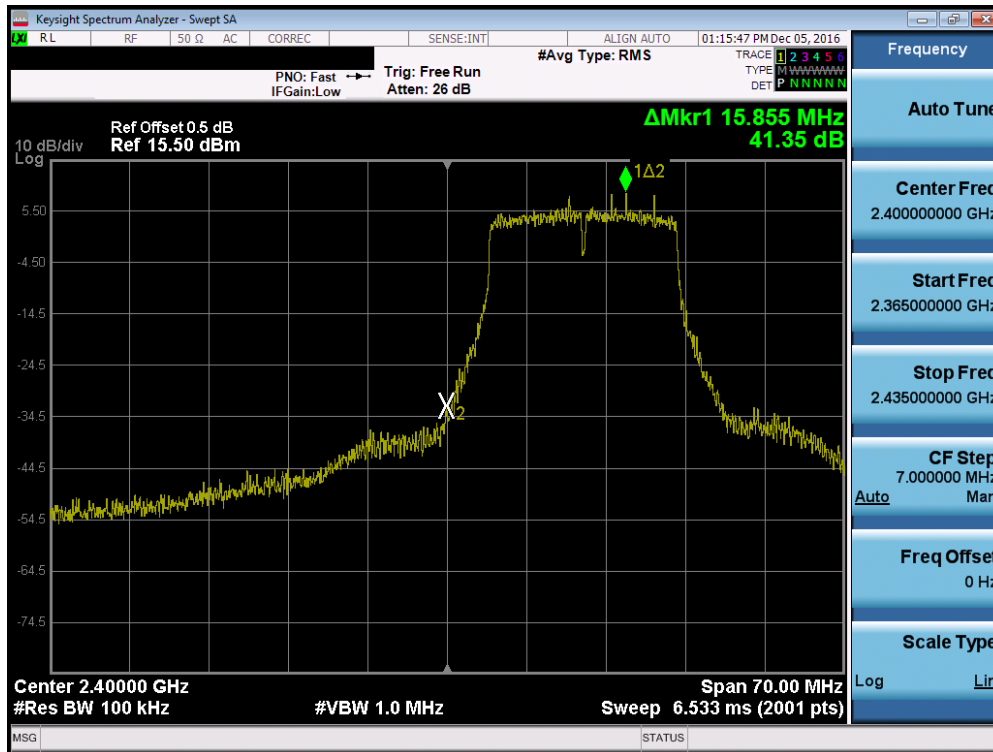

Plot 7-115. Band Edge Plot (802.11g– Ch. 1)

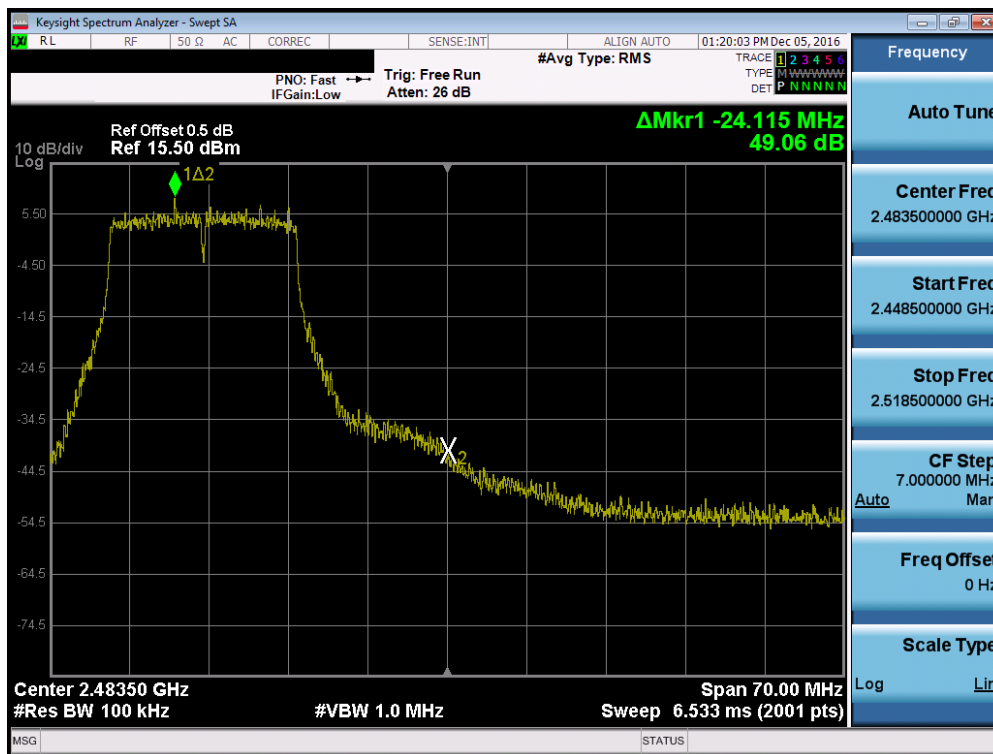

Plot 7-116. Band Edge Plot (802.11g – Ch. 11)

FCC ID: A3LETWV531	PCTEST ENGINEERING LABORATORY, INC.	FCC Pt. 15.247 802.11b/g/n/ac MEASUREMENT REPORT (CERTIFICATION)	SAMSUNG	Approved by: Quality Manager
Test Report S/N: 1M1705180171-02.A3L	Test Dates: 11/23/2016-02/17/2017	EUT Type: Indoor Access Point		Page 87 of 196

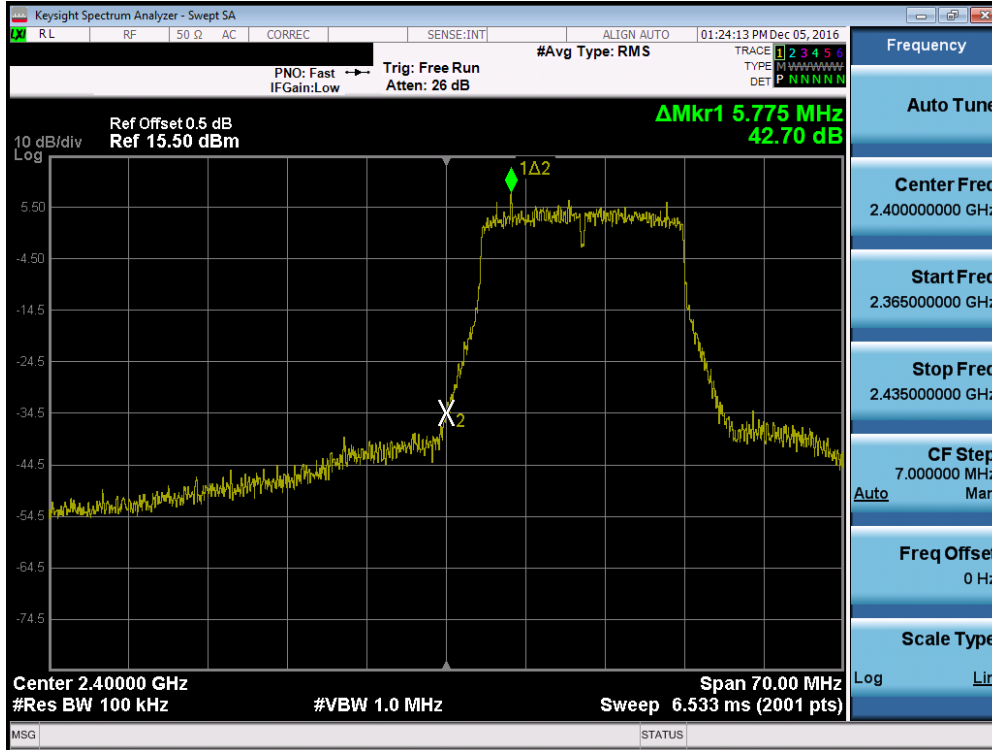

Plot 7-117. Band Edge Plot (802.11n (2.4GHz) – Ch. 1)

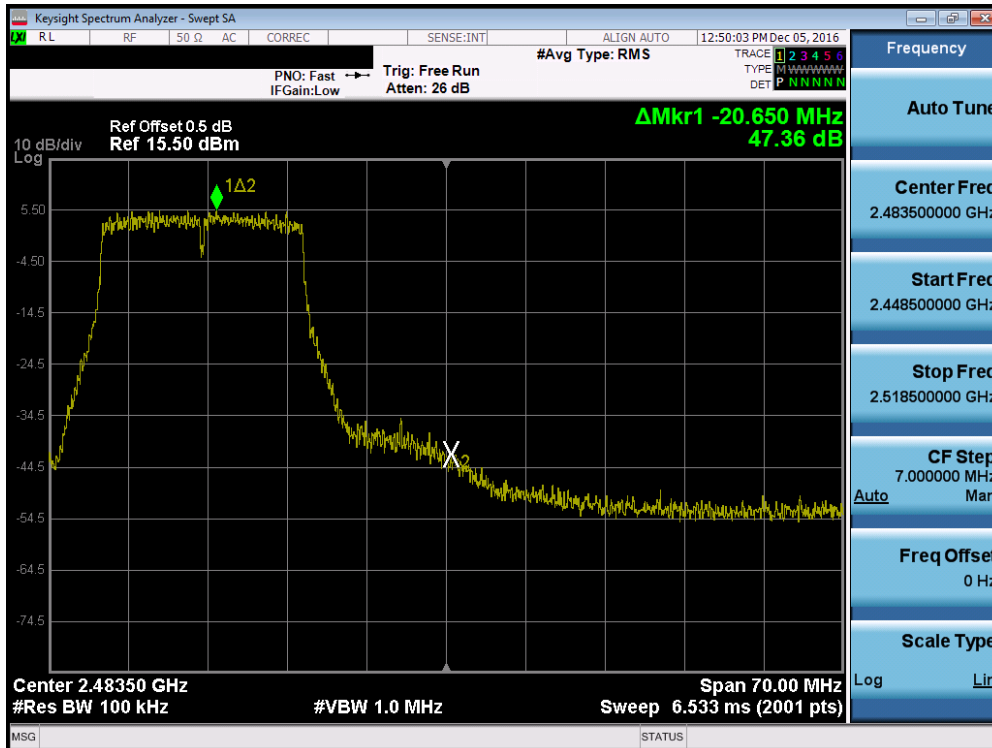

Plot 7-118. Band Edge Plot (802.11n (2.4GHz) – Ch. 11)

FCC ID: A3LETWV531		FCC Pt. 15.247 802.11b/g/n/ac MEASUREMENT REPORT (CERTIFICATION)		Approved by: Quality Manager
Test Report S/N: 1M1705180171-02.A3L	Test Dates: 11/23/2016-02/17/2017	EUT Type: Indoor Access Point		Page 88 of 196

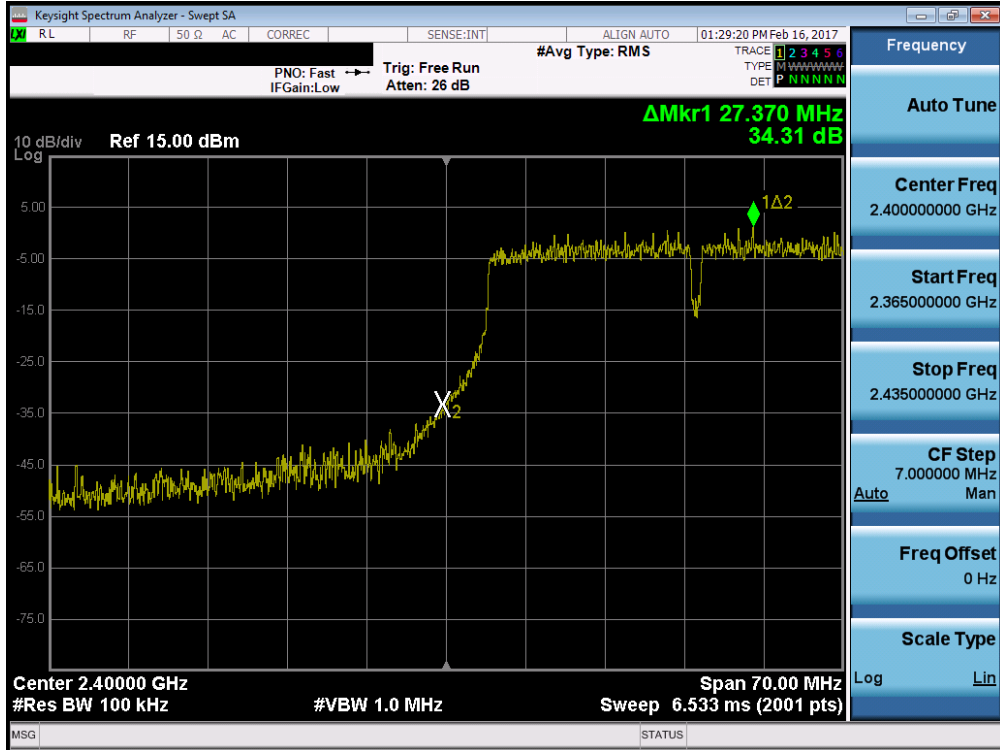

Plot 7-119. Band Edge Plot (40MHz 802.11n/ac – Ch. 3)

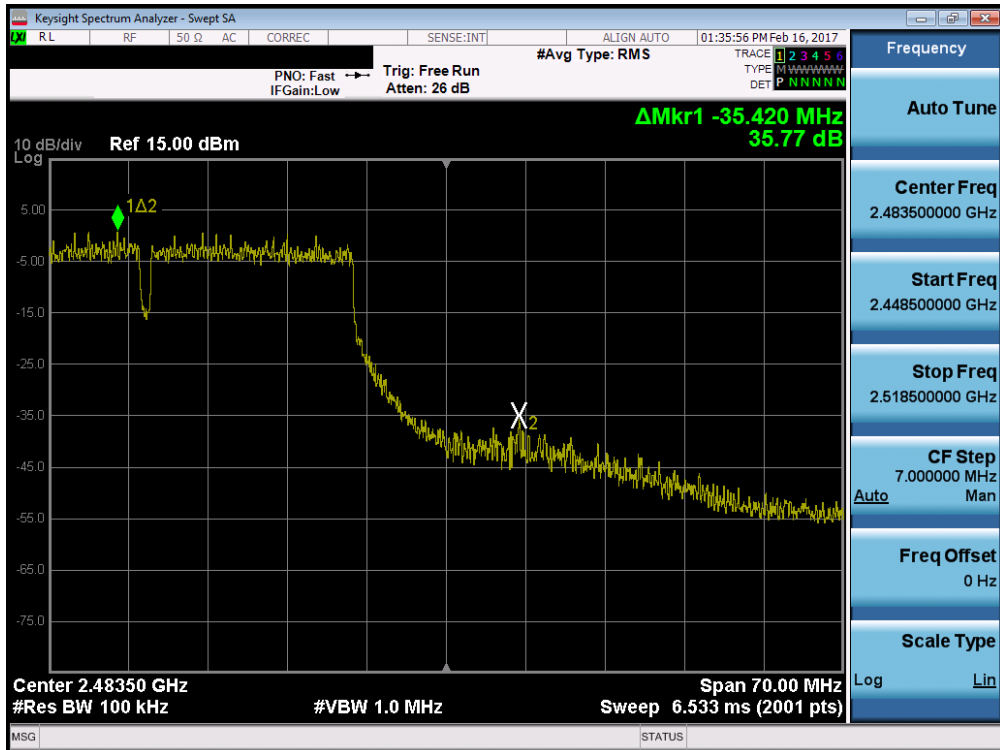

Plot 7-120. Band Edge Plot (40MHz 802.11n/ac – Ch. 10)

FCC ID: A3LETWV531		FCC Pt. 15.247 802.11b/g/n/ac MEASUREMENT REPORT (CERTIFICATION)		Approved by: Quality Manager
Test Report S/N: 1M1705180171-02.A3L	Test Dates: 11/23/2016-02/17/2017	EUT Type: Indoor Access Point		Page 89 of 196

Antenna-4 Conducted Emissions at the Band Edge

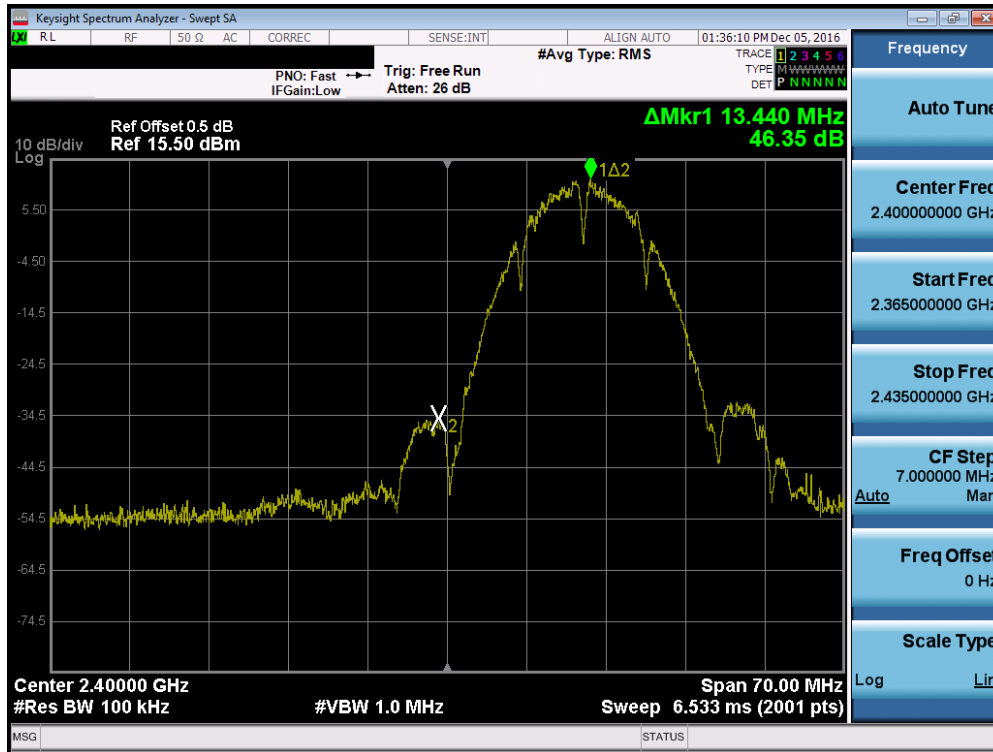

Plot 7-121. Band Edge Plot (802.11b – Ch. 1)

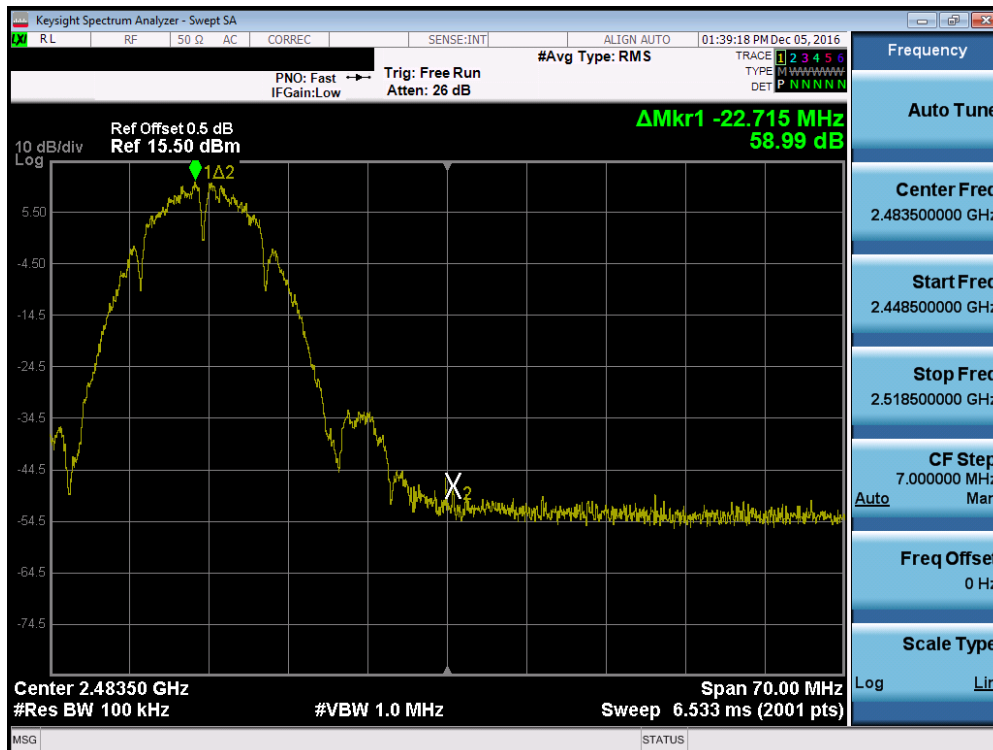

Plot 7-122. Band Edge Plot (802.11b – Ch. 11)

FCC ID: A3LETWV531		FCC Pt. 15.247 802.11b/g/n/ac MEASUREMENT REPORT (CERTIFICATION)		Approved by: Quality Manager
Test Report S/N: 1M1705180171-02.A3L	Test Dates: 11/23/2016-02/17/2017	EUT Type: Indoor Access Point		Page 90 of 196

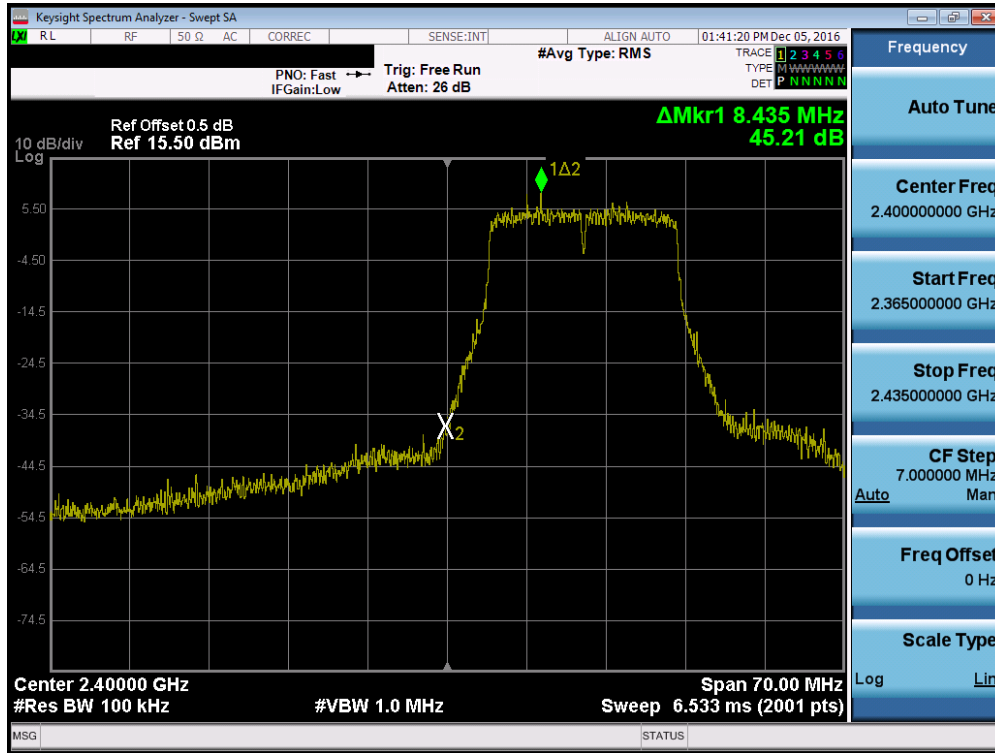

Plot 7-123. Band Edge Plot (802.11g– Ch. 1)

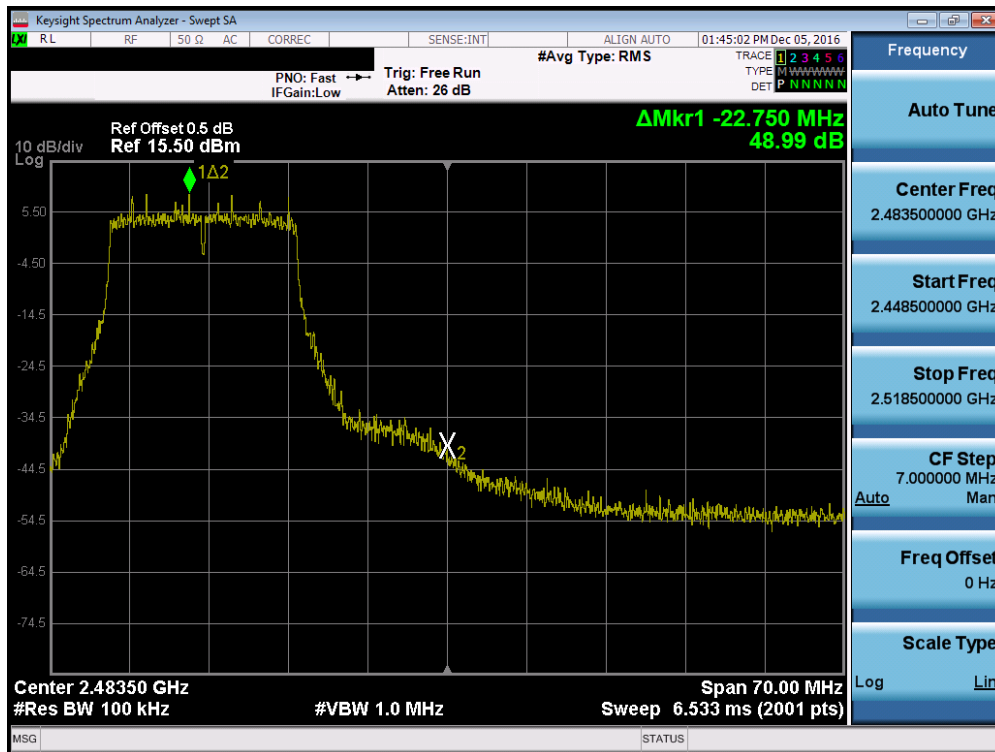

Plot 7-124. Band Edge Plot (802.11g – Ch. 11)

FCC ID: A3LETWV531	PCTEST ENGINEERING LABORATORY, INC.	FCC Pt. 15.247 802.11b/g/n/ac MEASUREMENT REPORT (CERTIFICATION)	SAMSUNG	Approved by: Quality Manager
Test Report S/N: 1M1705180171-02.A3L	Test Dates: 11/23/2016-02/17/2017	EUT Type: Indoor Access Point		Page 91 of 196

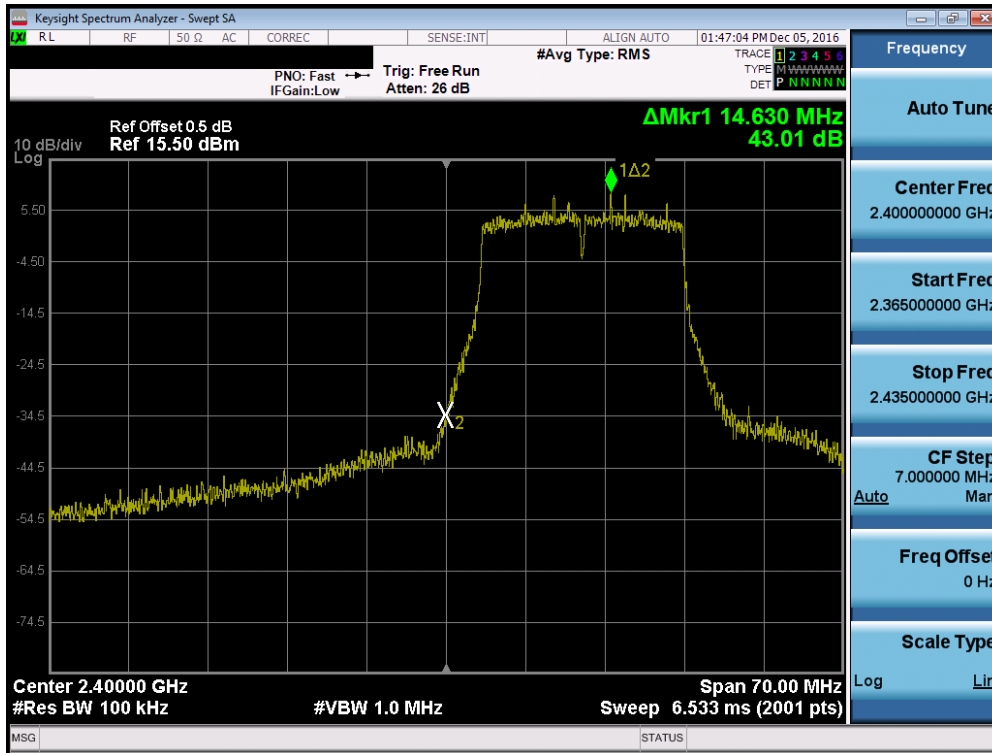

Plot 7-125. Band Edge Plot (802.11n (2.4GHz) – Ch. 1)

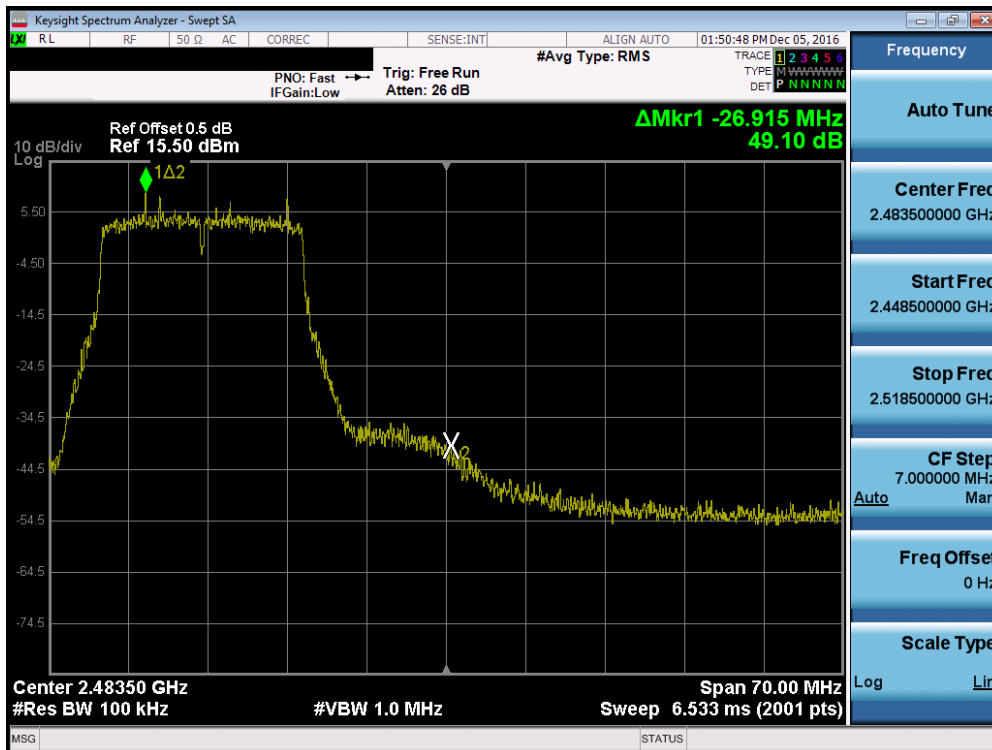

Plot 7-126. Band Edge Plot (802.11n (2.4GHz) – Ch. 11)

FCC ID: A3LETWV531		FCC Pt. 15.247 802.11b/g/n/ac MEASUREMENT REPORT (CERTIFICATION)		Approved by: Quality Manager
Test Report S/N: 1M1705180171-02.A3L	Test Dates: 11/23/2016-02/17/2017	EUT Type: Indoor Access Point		Page 92 of 196

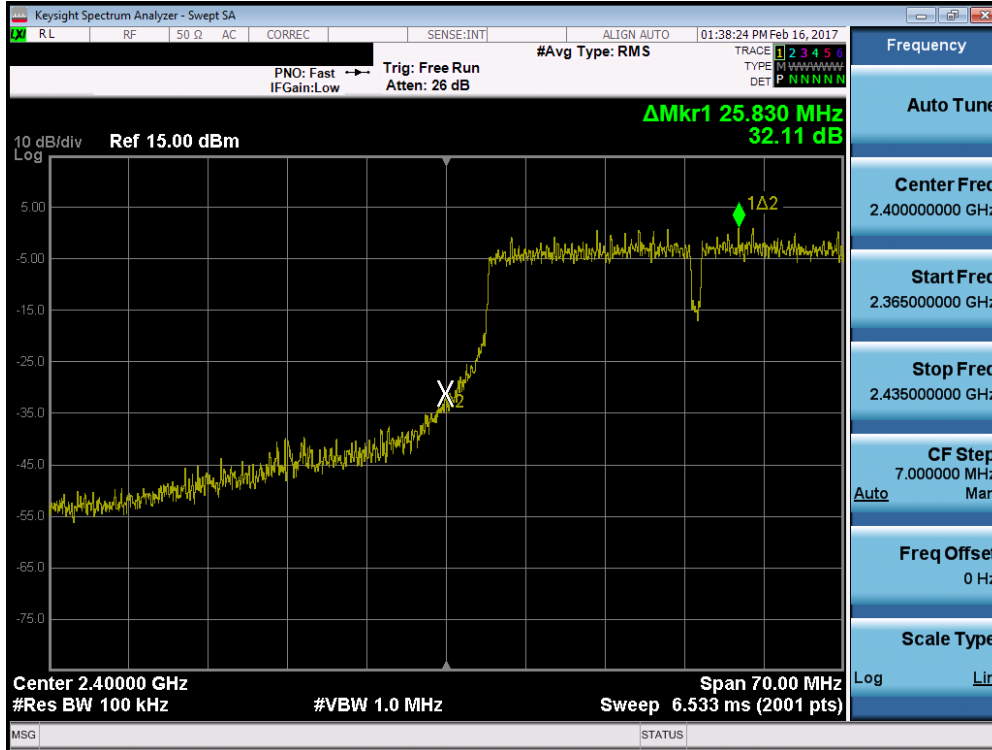

Plot 7-127. Band Edge Plot (40MHz 802.11n/ac – Ch. 3)

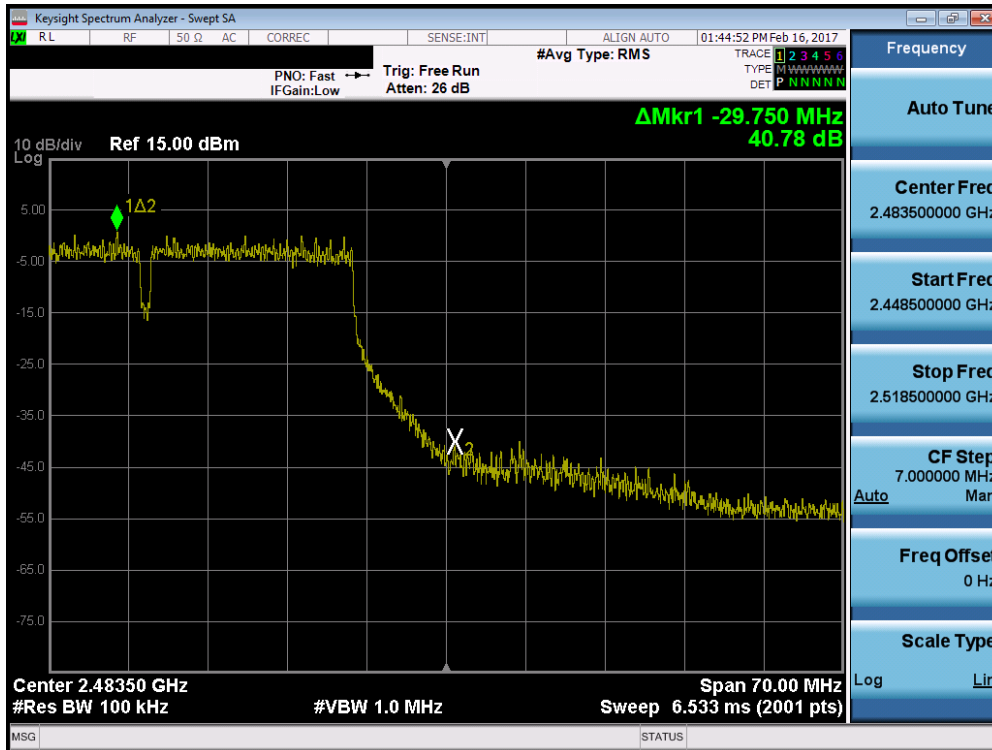

Plot 7-128. Band Edge Plot (40MHz 802.11n/ac – Ch. 10)

FCC ID: A3LETWV531		FCC Pt. 15.247 802.11b/g/n/ac MEASUREMENT REPORT (CERTIFICATION)		Approved by: Quality Manager
Test Report S/N: 1M1705180171-02.A3L	Test Dates: 11/23/2016-02/17/2017	EUT Type: Indoor Access Point		Page 93 of 196

7.6 Conducted Spurious Emissions §15.247(d)

Test Overview and Limit

All out of band emissions are measured with a spectrum analyzer connected to the antenna terminal of the EUT while the EUT is operating at its maximum duty cycle, at maximum power, and at the appropriate frequencies. All data rates were investigated to determine the worst case configuration. For the following out of band conducted spurious emissions plots, the EUT was investigated in all available data rates for “b”, “g”, and “n” modes. The worst case spurious emissions for the 2.4GHz band were found while transmitting in “b” mode at 1 Mbps and are shown in the plots below.

The limit for out-of-band spurious emissions at the band edge is 30dB below the fundamental emission level, as determined from the in-band power measurement of the DTS channel performed in a 100kHz bandwidth per the procedure in Section 11.1 of KDB 558074 D01 v04.

Test Procedure Used

KDB 558074 D01 v04 – Section 11.3
KDB 662911 D01 v02r01 – Section E)3)b)

Test Settings

1. Start frequency was set to 30MHz and stop frequency was set to 25GHz (separated into two plots per channel)
2. RBW = 1MHz
3. VBW = 3MHz
4. Detector = Peak
5. Trace mode = max hold
6. Sweep time = auto couple
7. The trace was allowed to stabilize

Test Setup

The EUT and measurement equipment were set up as shown in the diagram below.

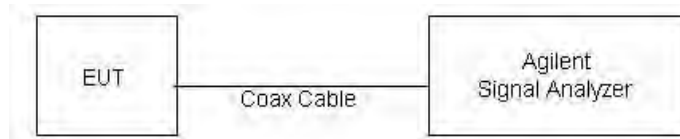





Figure 7-5. Test Instrument & Measurement Setup

FCC ID: A3LETWV531		FCC Pt. 15.247 802.11b/g/n/ac MEASUREMENT REPORT (CERTIFICATION)		Approved by: Quality Manager
Test Report S/N: 1M1705180171-02.A3L	Test Dates: 11/23/2016-02/17/2017	EUT Type: Indoor Access Point	Page 94 of 196	

Test Notes

1. RBW was set to 1MHz rather than 100kHz in order to increase the measurement speed.
2. The display line shown in the following plots denotes the limit at 30dB below the fundamental emission level measured in a 100kHz bandwidth. However, since the traces in the following plots are measured with a 1MHz RBW, the display line may not necessarily appear to be 30dB below the level of the fundamental in a 1MHz bandwidth.
3. For plots showing conducted spurious emissions near the limit, the frequencies were investigated with a reduced RBW to ensure that no emissions were present.
4. Conducted spurious emissions are only shown for 20MHz bandwidth channels since they were determined to be the worst case.
5. The conducted spurious emissions were measured to relative limits. Therefore, in accordance with KDB 662911 D01 v02r01 Section E)3)b), it was unnecessary to show compliance through the summation of test results of the individual outputs.

FCC ID: A3LETWV531		FCC Pt. 15.247 802.11b/g/n/ac MEASUREMENT REPORT (CERTIFICATION)		Approved by: Quality Manager
Test Report S/N: 1M1705180171-02.A3L	Test Dates: 11/23/2016-02/17/2017	EUT Type: Indoor Access Point	Page 95 of 196	

Antenna-1 Conducted Spurious Emission (20MHz BW)

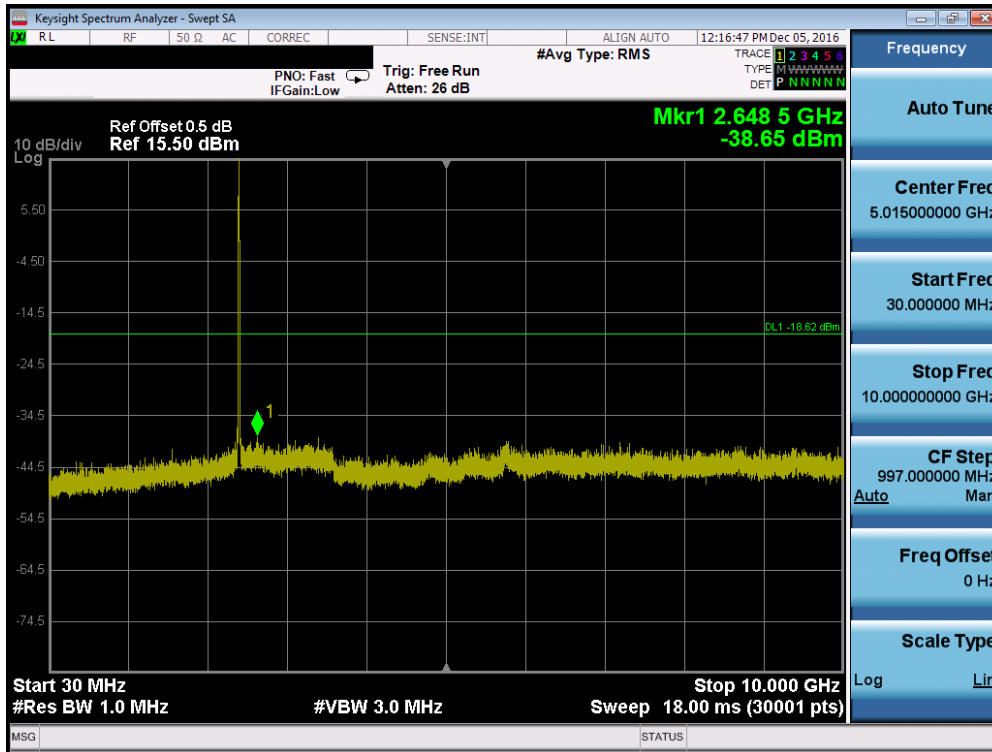

Plot 7-129. Conducted Spurious Plot (802.11b – Ch. 1)

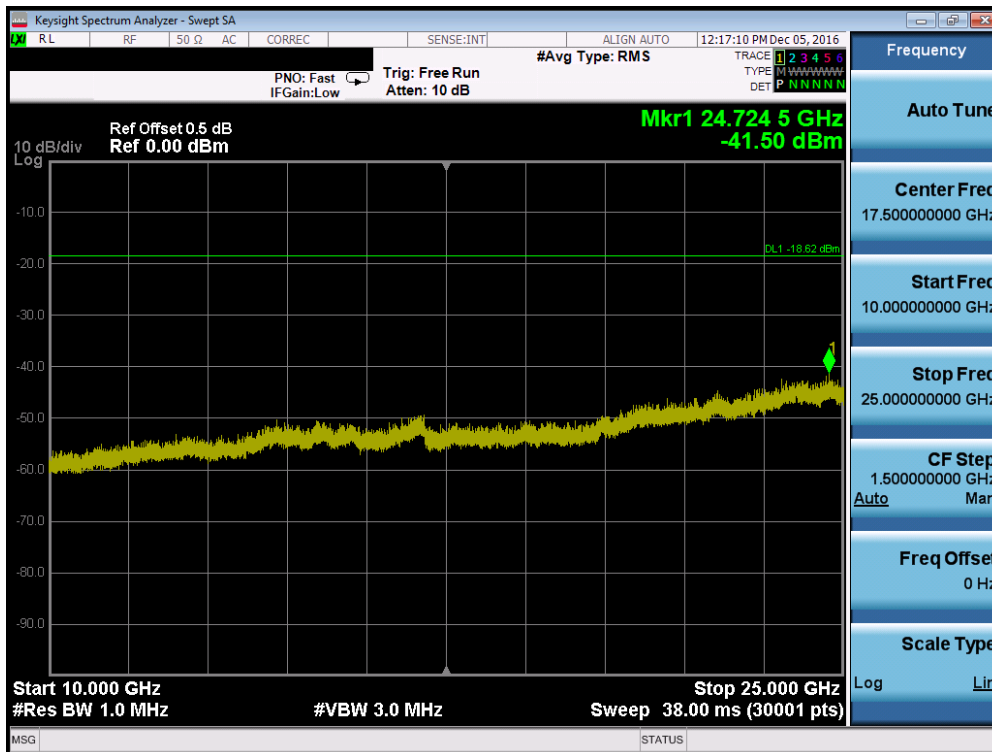

Plot 7-130. Conducted Spurious Plot (802.11b – Ch. 1)

FCC ID: A3LETWV531		FCC Pt. 15.247 802.11b/g/n/ac MEASUREMENT REPORT (CERTIFICATION)		Approved by: Quality Manager
Test Report S/N: 1M1705180171-02.A3L	Test Dates: 11/23/2016-02/17/2017	EUT Type: Indoor Access Point		Page 96 of 196

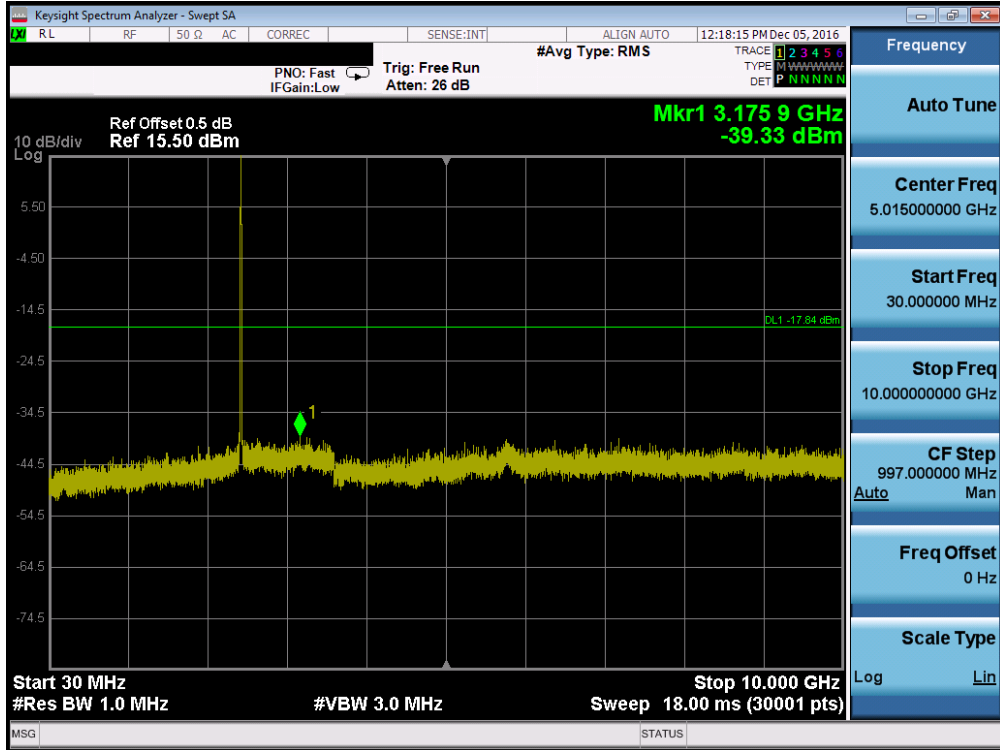

Plot 7-131. Conducted Spurious Plot (802.11b – Ch. 6)

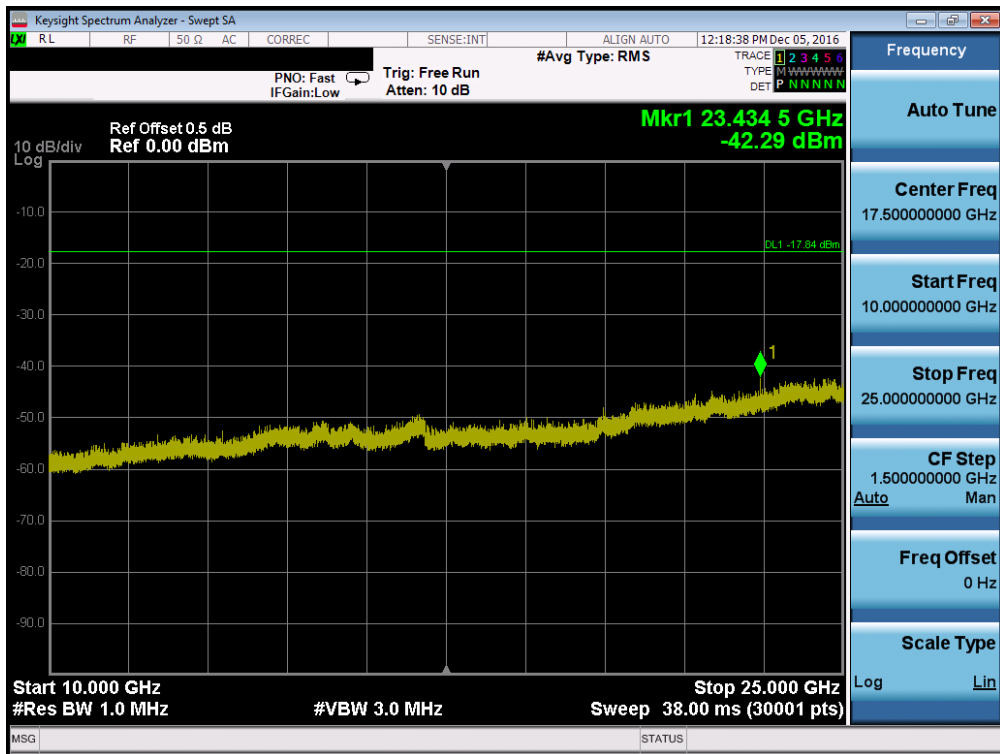

Plot 7-132. Conducted Spurious Plot (802.11b – Ch. 6)

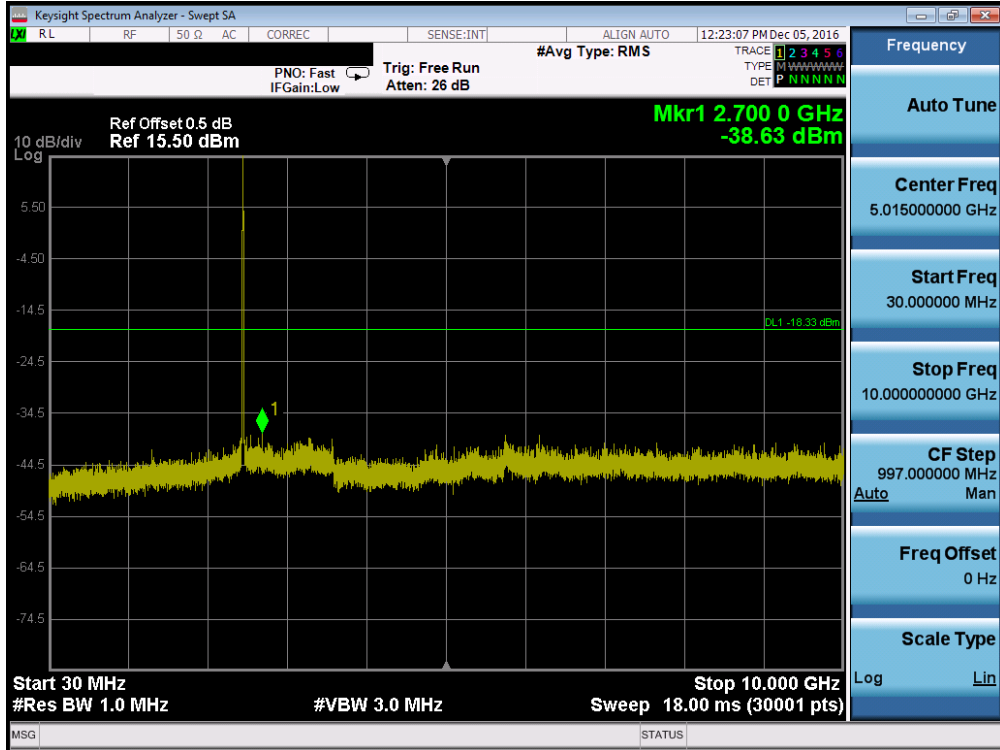

FCC ID: A3LETWV531		FCC Pt. 15.247 802.11b/g/n/ac MEASUREMENT REPORT (CERTIFICATION)		Approved by: Quality Manager
Test Report S/N: 1M1705180171-02.A3L	Test Dates: 11/23/2016-02/17/2017	EUT Type: Indoor Access Point		Page 97 of 196

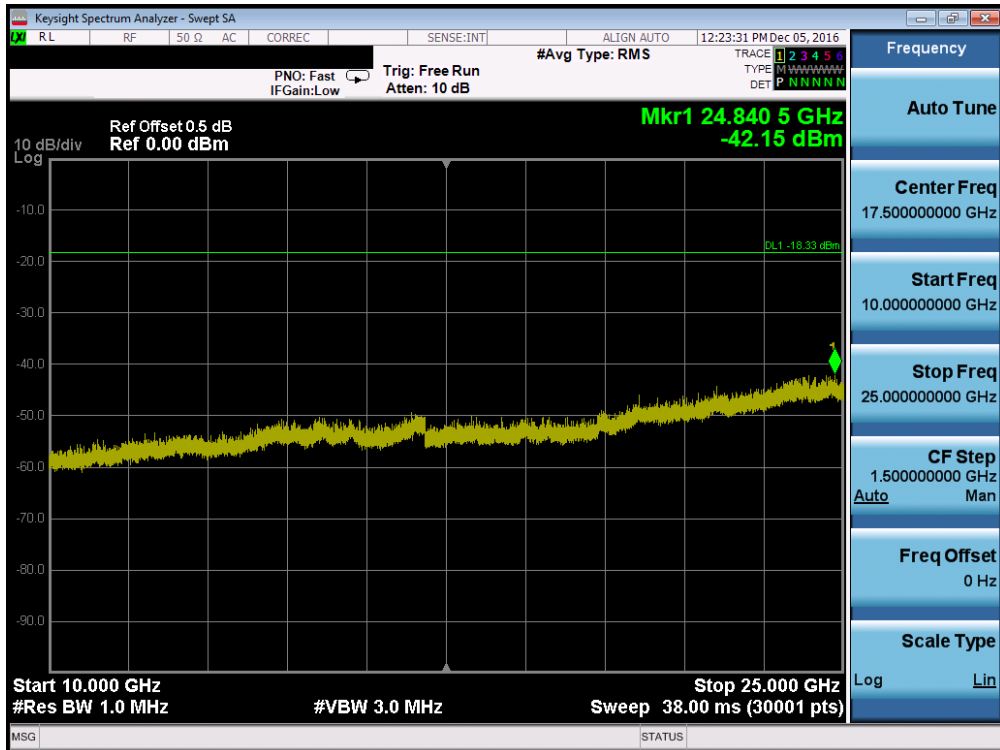

Plot 7-133. Conducted Spurious Plot (802.11b – Ch. 11)



Plot 7-134. Conducted Spurious Plot (802.11b – Ch. 11)

FCC ID: A3LETWV531		FCC Pt. 15.247 802.11b/g/n/ac MEASUREMENT REPORT (CERTIFICATION)		Approved by: Quality Manager
Test Report S/N: 1M1705180171-02.A3L	Test Dates: 11/23/2016-02/17/2017	EUT Type: Indoor Access Point		Page 98 of 196

Antenna-2 Conducted Spurious Emission (20MHz BW)

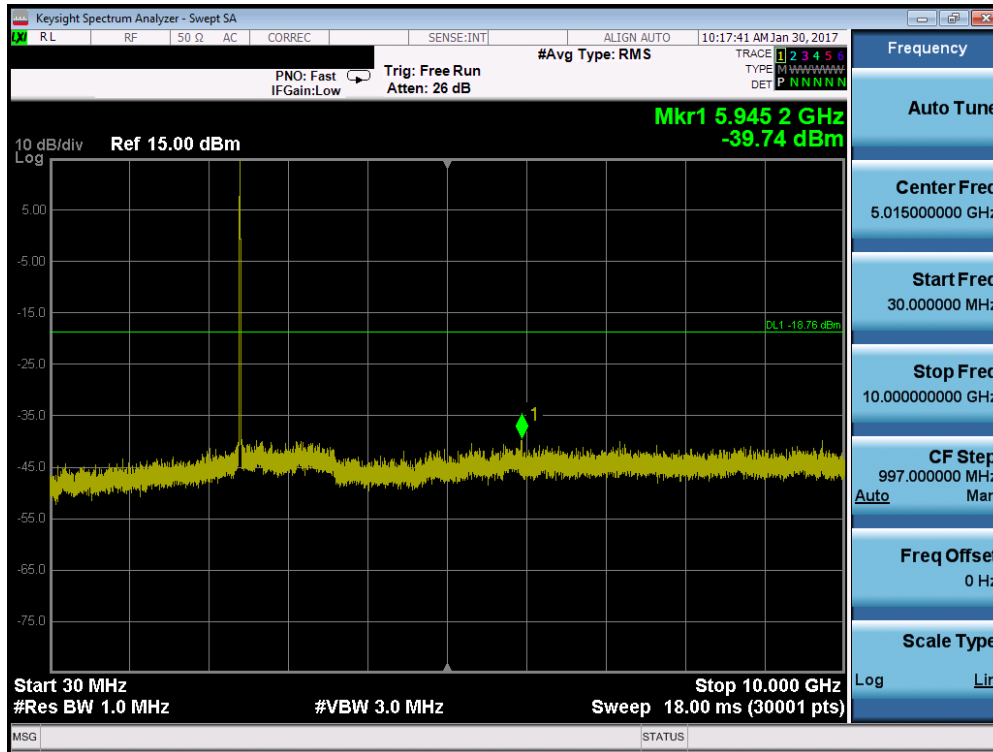

Plot 7-135. Conducted Spurious Plot (802.11b – Ch. 1)

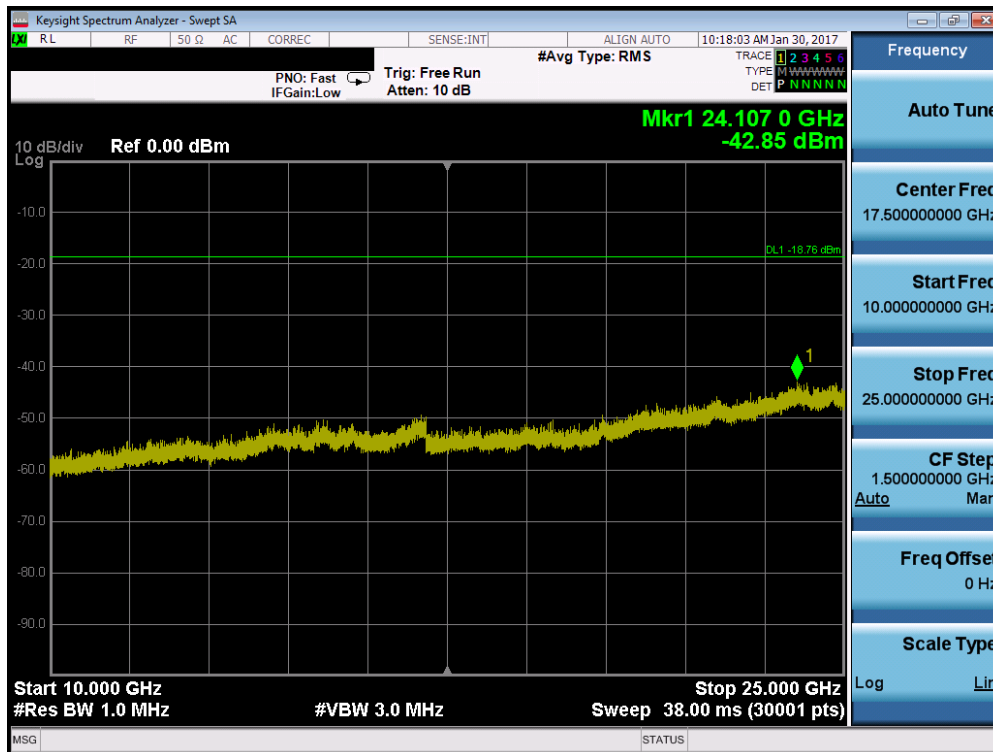

Plot 7-136. Conducted Spurious Plot (802.11b – Ch. 1)

FCC ID: A3LETWV531		FCC Pt. 15.247 802.11b/g/n/ac MEASUREMENT REPORT (CERTIFICATION)		Approved by: Quality Manager
Test Report S/N: 1M1705180171-02.A3L	Test Dates: 11/23/2016-02/17/2017	EUT Type: Indoor Access Point		Page 99 of 196

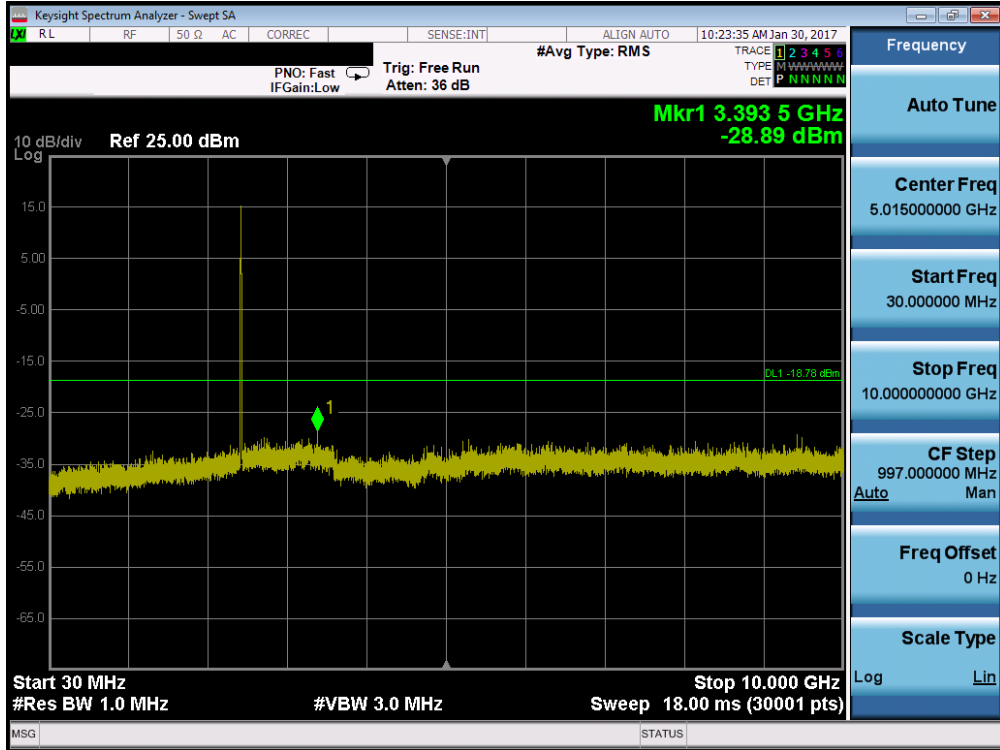

Plot 7-137. Conducted Spurious Plot (802.11b – Ch. 6)

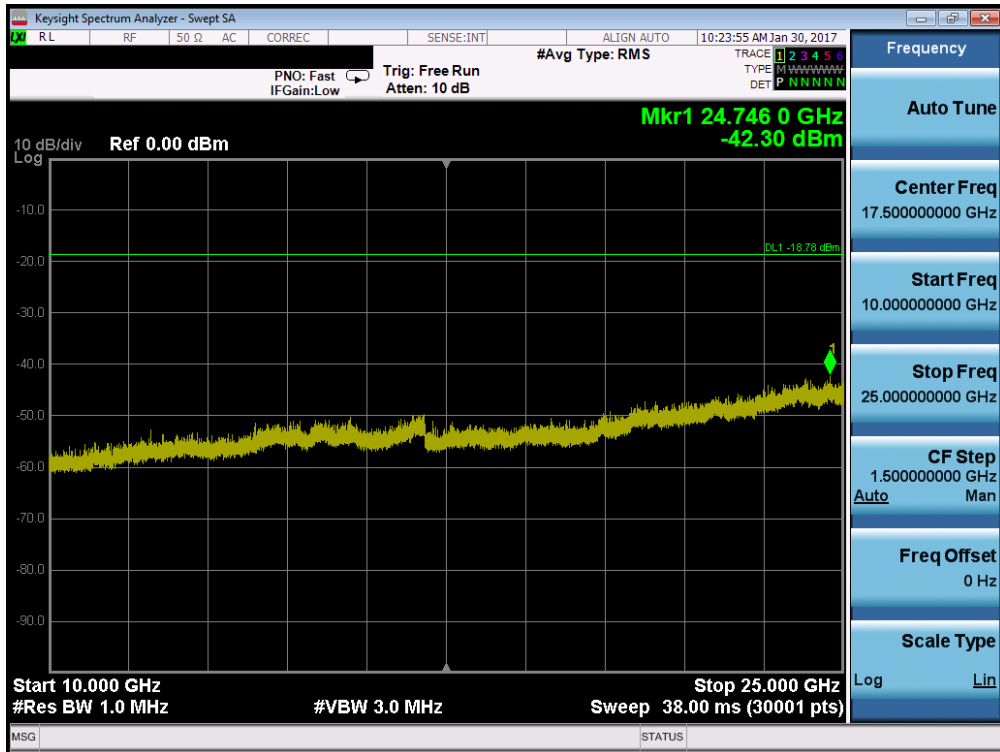

Plot 7-138. Conducted Spurious Plot (802.11b – Ch. 6)

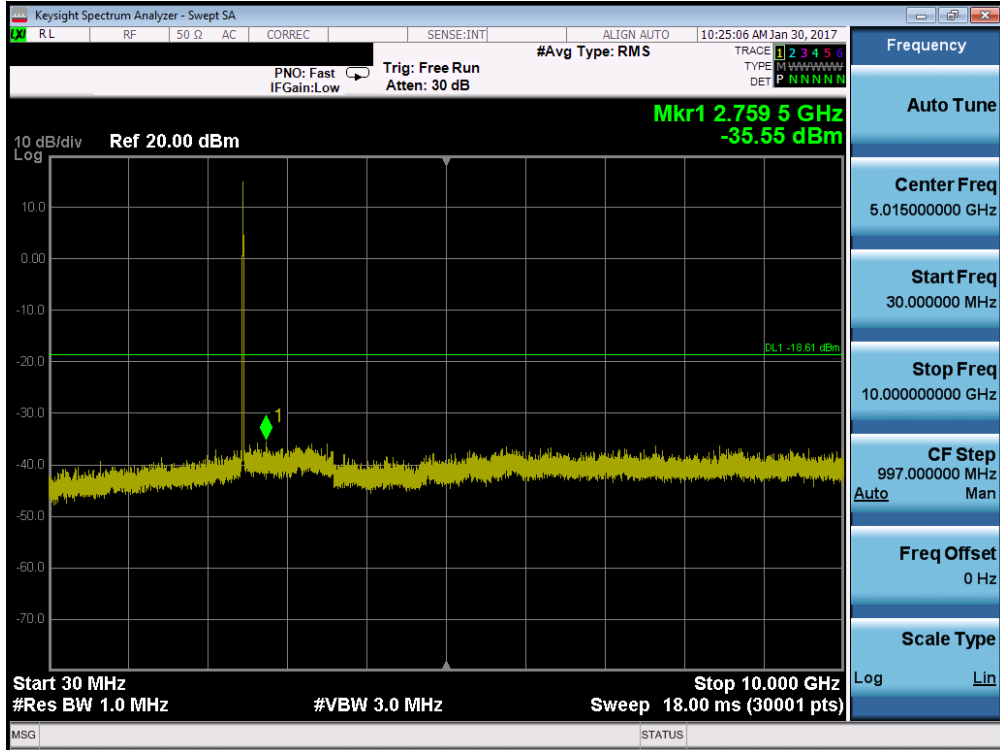

FCC ID: A3LETWV531		FCC Pt. 15.247 802.11b/g/n/ac MEASUREMENT REPORT (CERTIFICATION)		Approved by: Quality Manager
Test Report S/N: 1M1705180171-02.A3L	Test Dates: 11/23/2016-02/17/2017	EUT Type: Indoor Access Point		Page 100 of 196

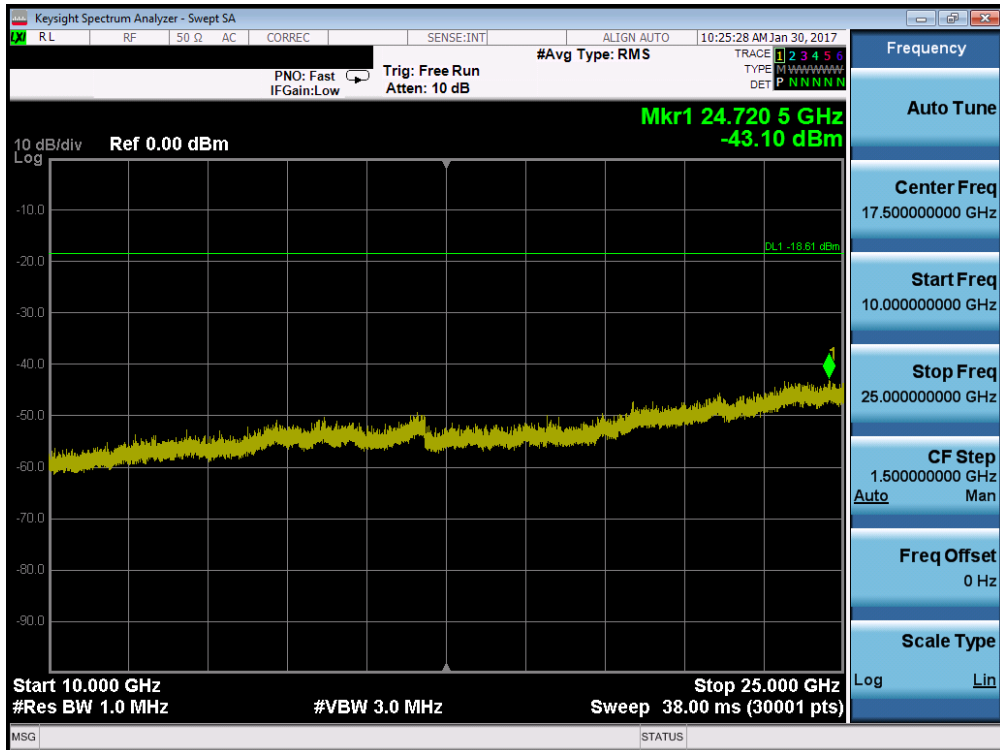

Plot 7-139. Conducted Spurious Plot (802.11b – Ch. 11)



Plot 7-140. Conducted Spurious Plot (802.11b – Ch. 11)

FCC ID: A3LETWV531		FCC Pt. 15.247 802.11b/g/n/ac MEASUREMENT REPORT (CERTIFICATION)		Approved by: Quality Manager
Test Report S/N: 1M1705180171-02.A3L	Test Dates: 11/23/2016-02/17/2017	EUT Type: Indoor Access Point		Page 101 of 196

Antenna-3 Conducted Spurious Emission (20MHz BW)

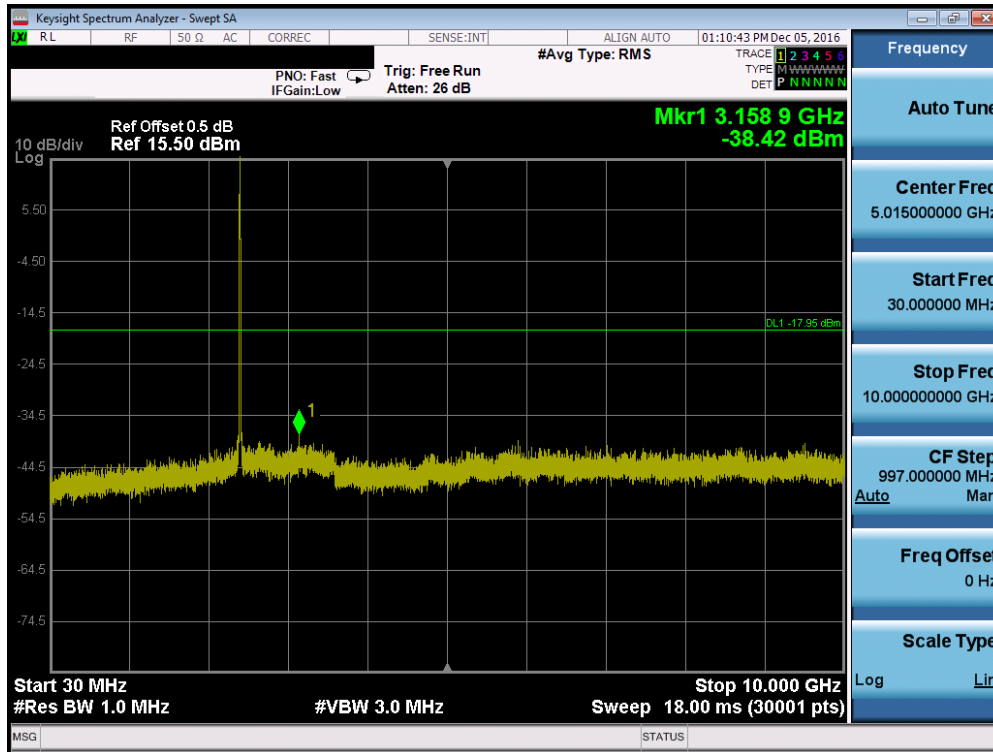

Plot 7-141. Conducted Spurious Plot (802.11b – Ch. 1)

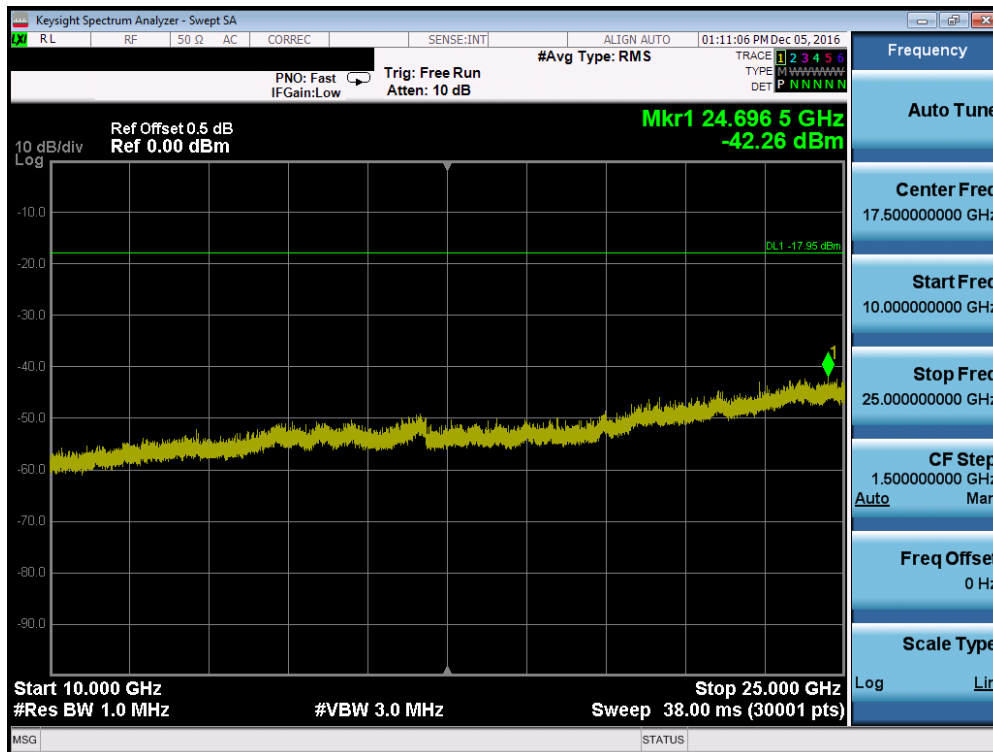

Plot 7-142. Conducted Spurious Plot (802.11b – Ch. 1)

FCC ID: A3LETWV531		FCC Pt. 15.247 802.11b/g/n/ac MEASUREMENT REPORT (CERTIFICATION)		Approved by: Quality Manager
Test Report S/N: 1M1705180171-02.A3L	Test Dates: 11/23/2016-02/17/2017	EUT Type: Indoor Access Point		Page 102 of 196

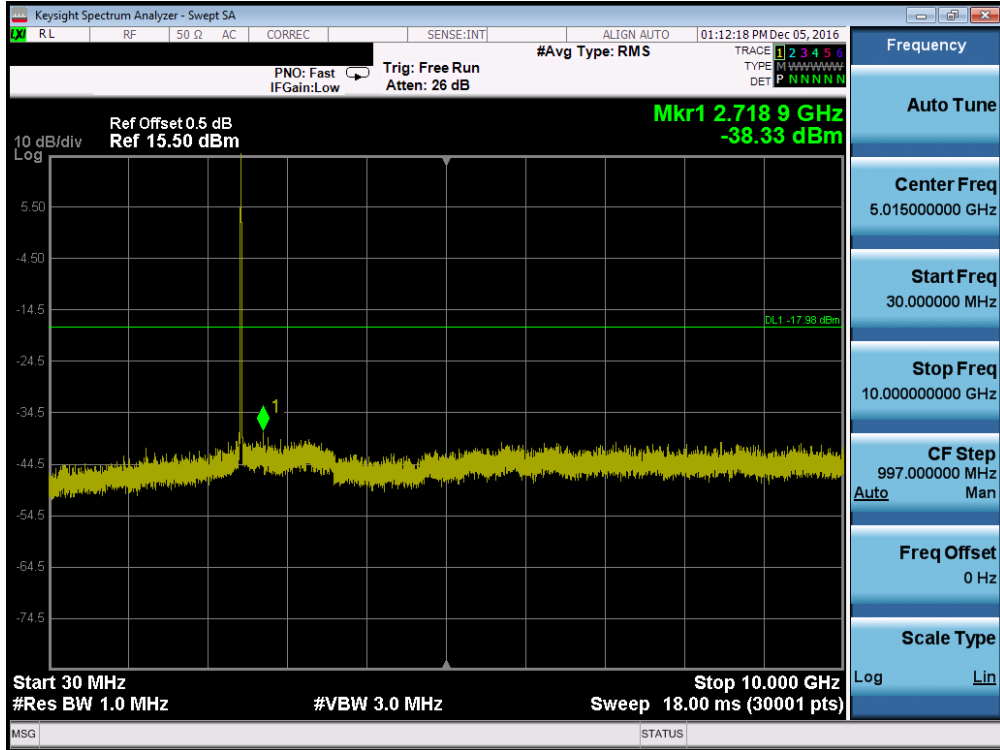

Plot 7-143. Conducted Spurious Plot (802.11b – Ch. 6)



Plot 7-144. Conducted Spurious Plot (802.11b – Ch. 6)

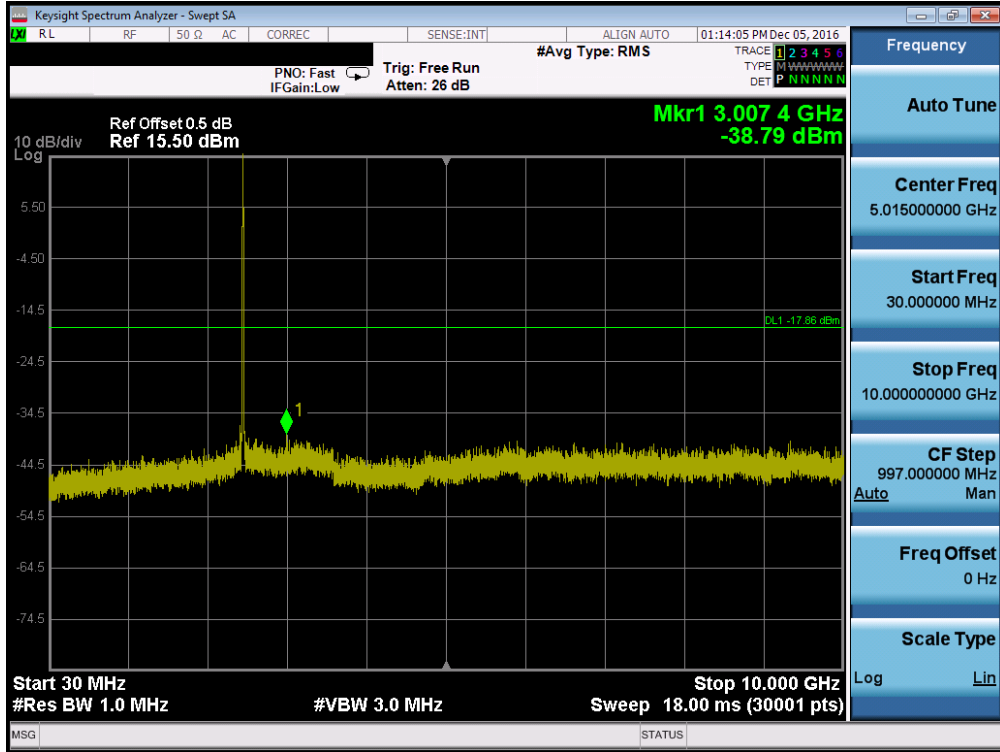

FCC ID: A3LETWV531		FCC Pt. 15.247 802.11b/g/n/ac MEASUREMENT REPORT (CERTIFICATION)		Approved by: Quality Manager
Test Report S/N: 1M1705180171-02.A3L	Test Dates: 11/23/2016-02/17/2017	EUT Type: Indoor Access Point		Page 103 of 196

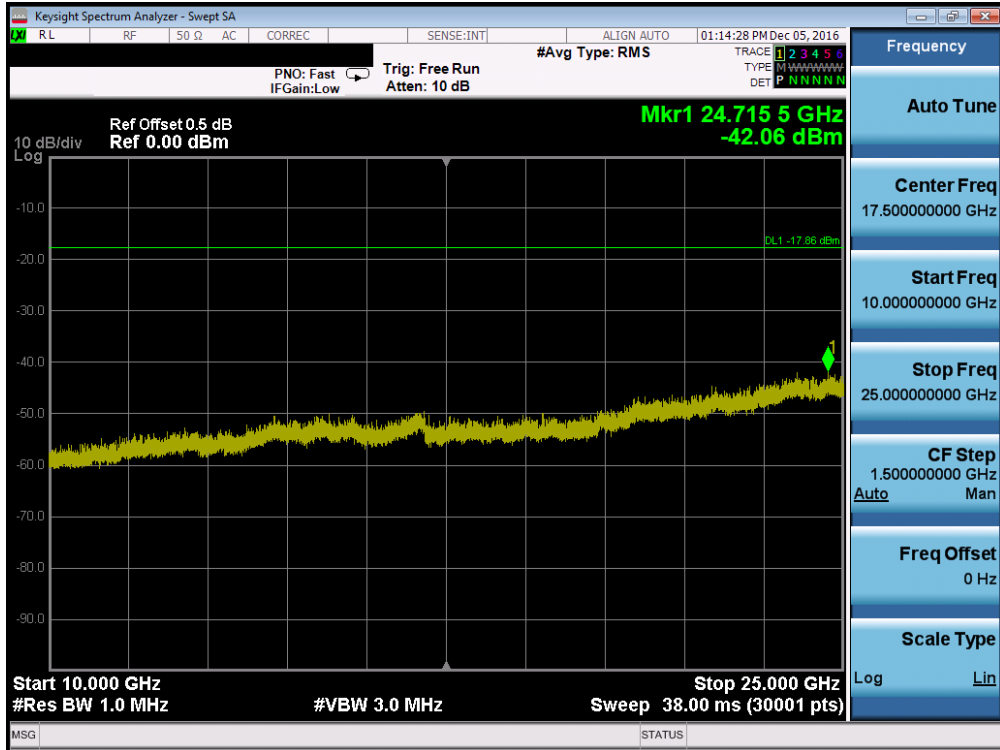

Plot 7-145. Conducted Spurious Plot (802.11b – Ch. 11)



Plot 7-146. Conducted Spurious Plot (802.11b – Ch. 11)

FCC ID: A3LETWV531		FCC Pt. 15.247 802.11b/g/n/ac MEASUREMENT REPORT (CERTIFICATION)		Approved by: Quality Manager
Test Report S/N: 1M1705180171-02.A3L	Test Dates: 11/23/2016-02/17/2017	EUT Type: Indoor Access Point		Page 104 of 196

Antenna-4 Conducted Spurious Emission (20MHz BW)

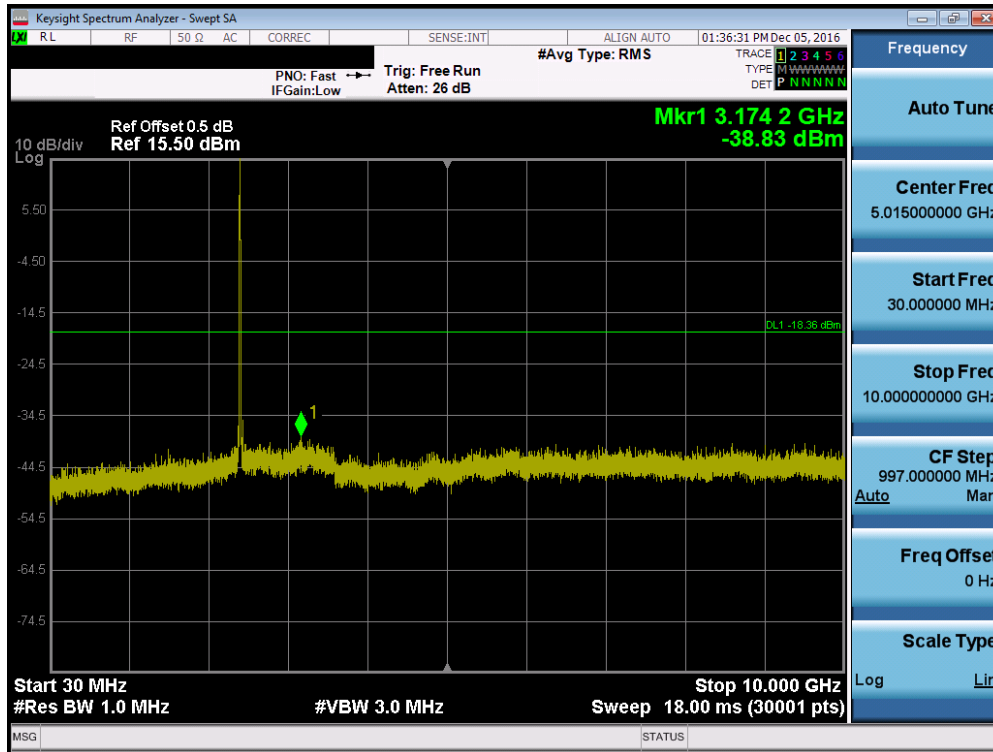

Plot 7-147. Conducted Spurious Plot (802.11b – Ch. 1)

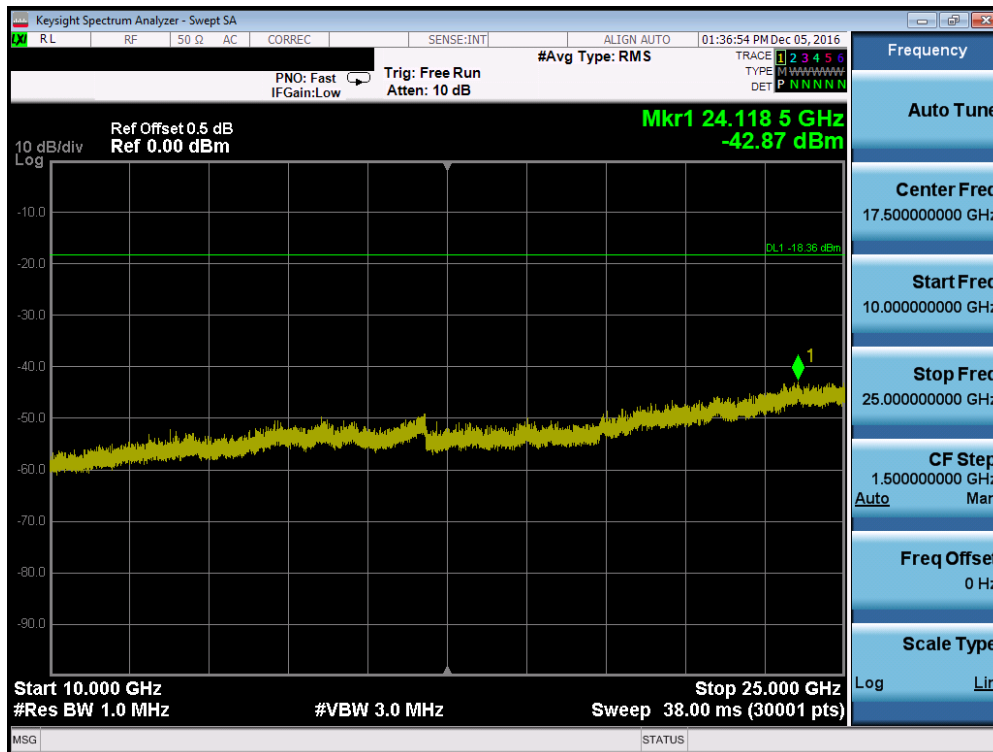

Plot 7-148. Conducted Spurious Plot (802.11b – Ch. 1)

FCC ID: A3LETWV531		FCC Pt. 15.247 802.11b/g/n/ac MEASUREMENT REPORT (CERTIFICATION)		Approved by: Quality Manager
Test Report S/N: 1M1705180171-02.A3L	Test Dates: 11/23/2016-02/17/2017	EUT Type: Indoor Access Point		Page 105 of 196

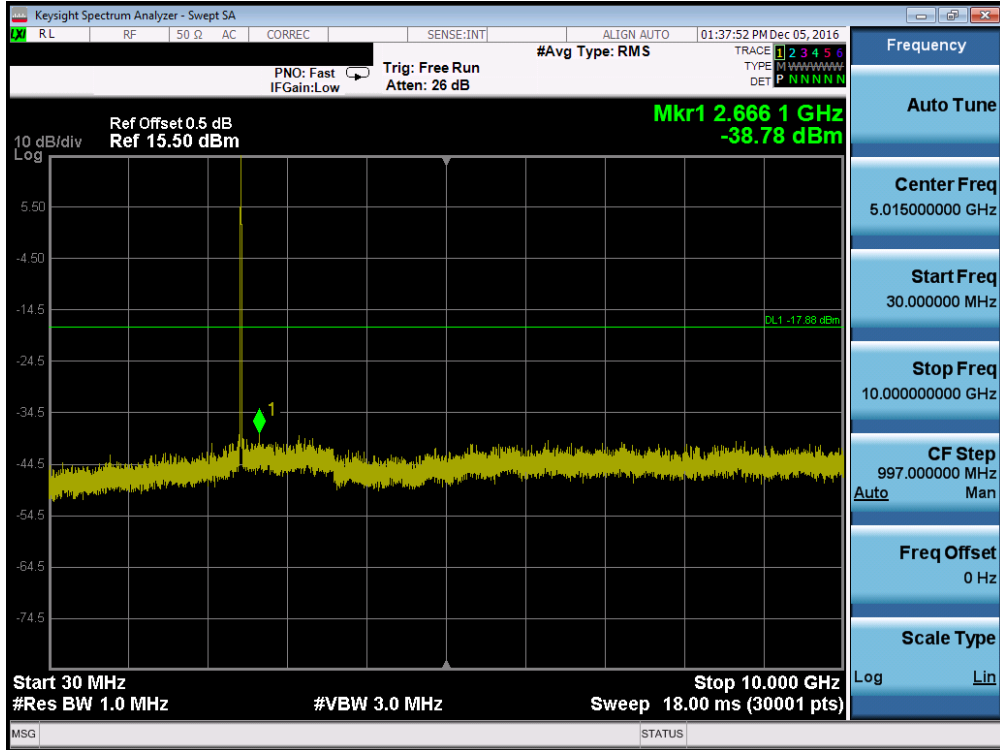

Plot 7-149. Conducted Spurious Plot (802.11b – Ch. 6)

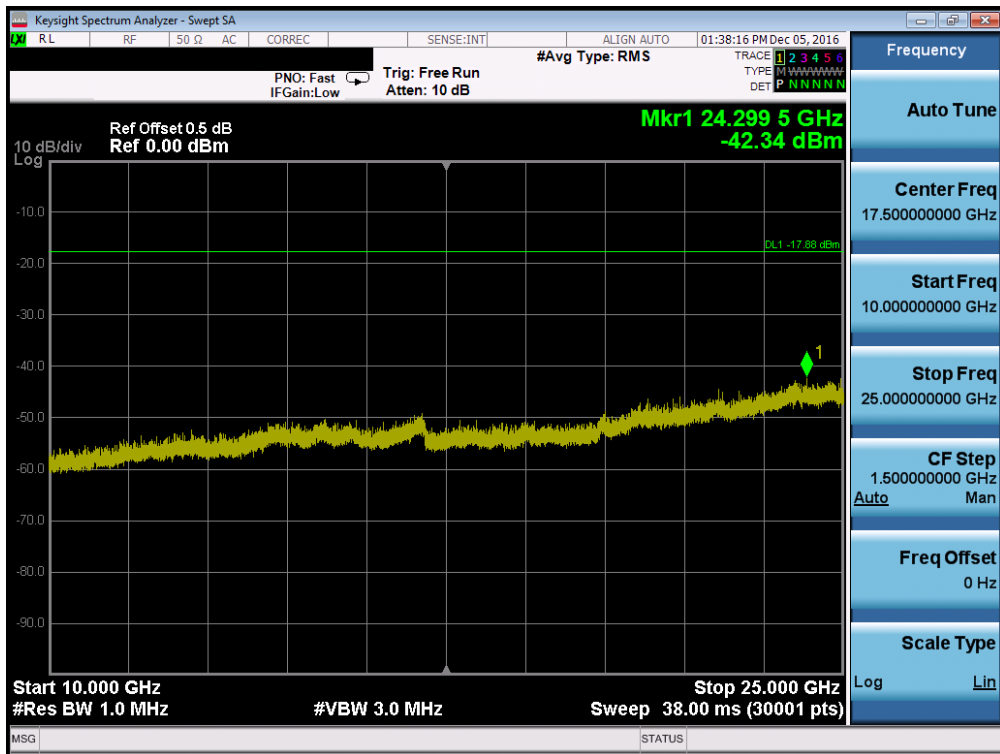

Plot 7-150. Conducted Spurious Plot (802.11b – Ch. 6)

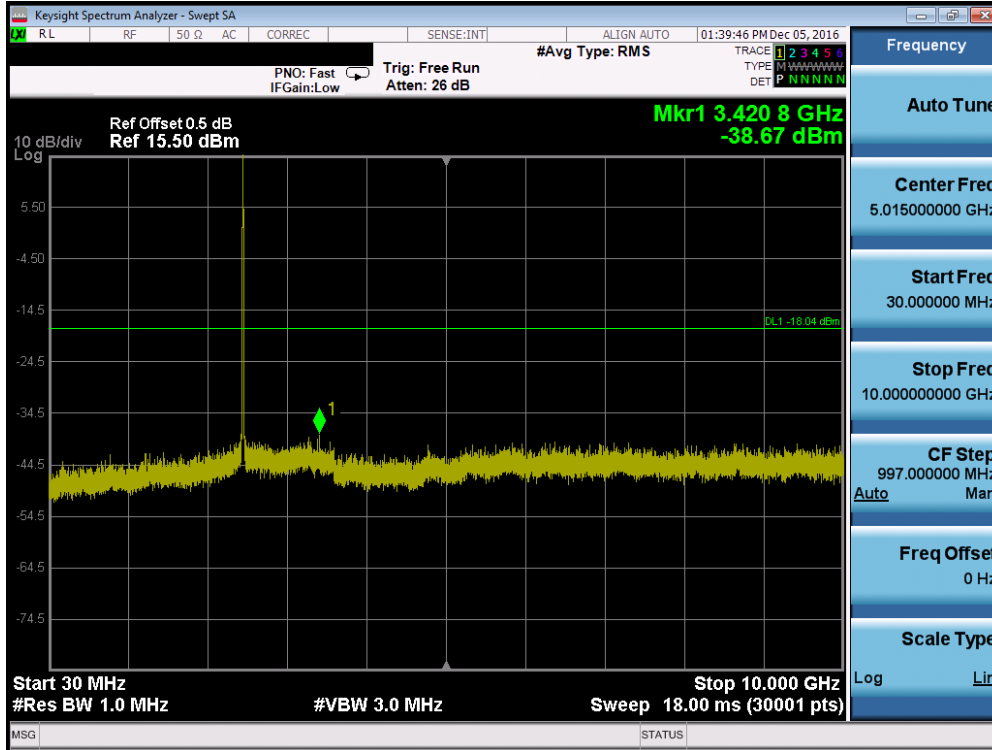

FCC ID: A3LETWV531		FCC Pt. 15.247 802.11b/g/n/ac MEASUREMENT REPORT (CERTIFICATION)		Approved by: Quality Manager
Test Report S/N: 1M1705180171-02.A3L	Test Dates: 11/23/2016-02/17/2017	EUT Type: Indoor Access Point		Page 106 of 196

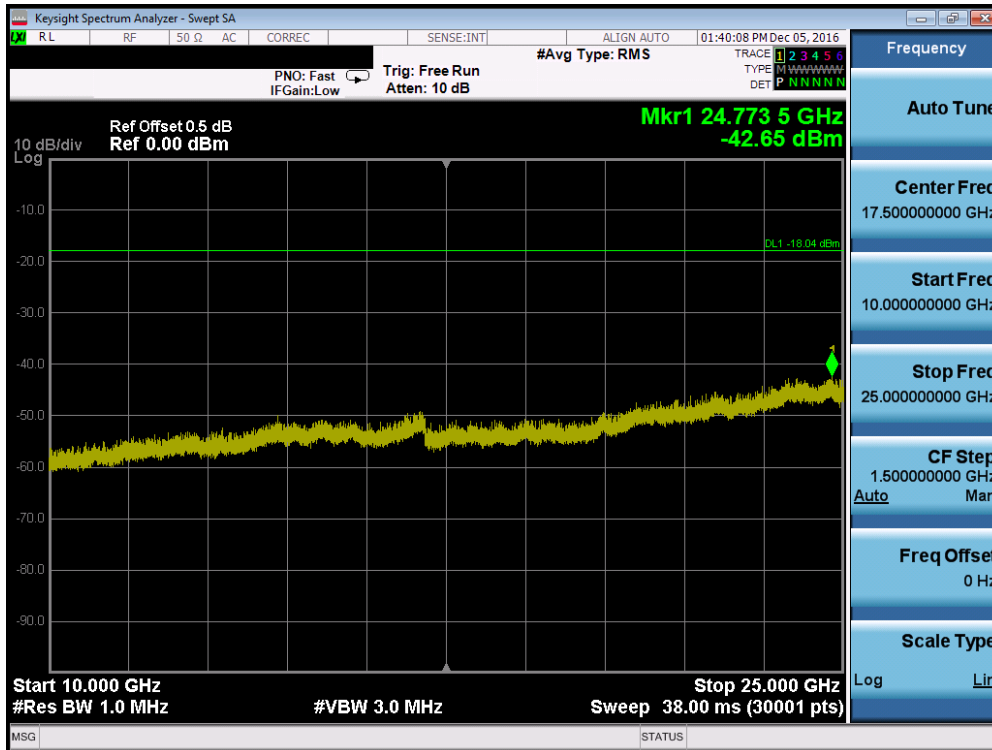

Plot 7-151. Conducted Spurious Plot (802.11b – Ch. 11)



Plot 7-152. Conducted Spurious Plot (802.11b – Ch. 11)

FCC ID: A3LETWV531		FCC Pt. 15.247 802.11b/g/n/ac MEASUREMENT REPORT (CERTIFICATION)		Approved by: Quality Manager
Test Report S/N: 1M1705180171-02.A3L	Test Dates: 11/23/2016-02/17/2017	EUT Type: Indoor Access Point		Page 107 of 196

7.7 Radiated Spurious Emission Measurements – Above 1 GHz

§15.247(d) §15.205 & §15.209

Test Overview and Limit

All out of band radiated spurious emissions are measured with a spectrum analyzer connected to a receive antenna while the EUT is operating at its maximum duty cycle, at maximum power, and at the appropriate frequencies. All data rates and modes were investigated for radiated spurious emissions. Only the radiated emissions of the configuration that produced the worst case emissions are reported in this section.

All out of band emissions appearing in a restricted band as specified in Section 15.205 of the Title 47 CFR must not exceed the limits shown in Table 7-25 per Section 15.209.

Frequency	Field Strength [$\mu\text{V}/\text{m}$]	Measured Distance [Meters]
Above 960.0 MHz	500	3

Table 7-25. Radiated Limits

Test Procedures Used

KDB 558074 D01 v04 – Section 12.1, 12.2.7



Test Settings

Average Field Strength Measurements per Section 12.2.5.1 of KDB 558074 D01 v04

1. Analyzer center frequency was set to the frequency of the radiated spurious emission of interest
2. RBW = 1MHz
3. VBW = 3MHz
4. Detector = power average (RMS)
5. Number of measurement points = 1001 (Number of points must be $\geq 2 \times \text{span}/\text{RBW}$)
6. Sweep time = auto
7. Trace (RMS) averaging was performed over at least 100 traces

Peak Field Strength Measurements per Section 12.2.4 of KDB 558074 D01 v04

1. Analyzer center frequency was set to the frequency of the radiated spurious emission of interest
2. RBW = 1MHz
3. VBW = 3MHz
4. Detector = peak
5. Sweep time = auto couple
6. Trace mode = max hold
7. Trace was allowed to stabilize

FCC ID: A3LETWV531		FCC Pt. 15.247 802.11b/g/n/ac MEASUREMENT REPORT (CERTIFICATION)		Approved by: Quality Manager
Test Report S/N: 1M1705180171-02.A3L	Test Dates: 11/23/2016-02/17/2017	EUT Type: Indoor Access Point	Page 108 of 196	

Test Setup

The EUT and measurement equipment were set up as shown in the diagram below.

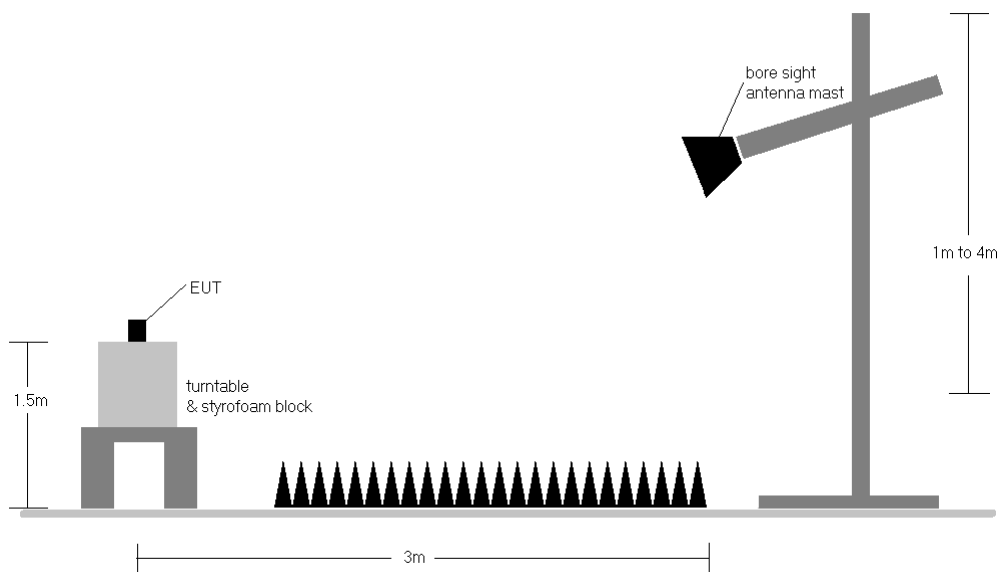



Figure 7-6. Test Instrument & Measurement Setup

Test Notes

1. The optional test procedures for antenna port conducted measurements of unwanted emissions per the guidance of KDB 558074 D01 v04 were not used to evaluate this device for compliance to radiated limits. All radiated spurious emissions levels were measured in a radiated test setup.
2. All emissions lying in restricted bands specified in §15.205 are below the limit shown in Table 7-25.
3. The antenna is manipulated through typical positions, polarity and length during the tests. The EUT is manipulated through three orthogonal planes.
4. This unit was tested with its standard battery.
5. The spectrum is measured from 9kHz to the 10th harmonic of the fundamental frequency of the transmitter using CISPR quasi peak detector below 1GHz. Above 1 GHz, average and peak measurements were taken using linearly polarized horn antennas. The worst-case emissions are reported however emissions whose levels were not within 20dB of the respective limits were not reported.
6. Emissions below 18GHz were measured at a 3 meter test distance while emissions above 18GHz were measured at a 1 meter test distance with the application of a distance correction factor.
7. Radiated spurious emissions were investigated while operating in MIMO mode, however, it was determined that single antenna operation produced the worst case emissions. Since the emissions

FCC ID: A3LETWV531		FCC Pt. 15.247 802.11b/g/n/ac MEASUREMENT REPORT (CERTIFICATION)		Approved by: Quality Manager
Test Report S/N: 1M1705180171-02.A3L	Test Dates: 11/23/2016-02/17/2017	EUT Type: Indoor Access Point		Page 109 of 196

produced from MIMO operation were found to be more than 20dB below the limit, the MIMO emissions are not reported.

8. The wide spectrum spurious emissions plots shown on the following pages are used only for the purpose of emission identification. Any emissions found to be within 20dB of the limit are fully investigated and the results are shown in this section. Rohde & Schwarz EMC32, Version 9.15.00 automated test software was used to perform the Radiated Spurious Emissions Pre-Scan testing.
9. Radiated spurious emissions are only shown for 20MHz bandwidth channels since they were determined to be the worst case.
10. The "-" shown in the following RSE tables are used to denote a noise floor measurement.
11. Emission at 1.7GHz, within 20dB of the limit was investigated, and does not originate from the EUT.

Sample Calculations



Determining Spurious Emissions Levels

- o Field Strength Level $_{[dB_{\mu V/m}]} = \text{Analyzer Level}_{[dBm]} + 107 + \text{AFCL}_{[dB/m]}$
- o $\text{AFCL}_{[dB/m]} = \text{Antenna Factor}_{[dB/m]} + \text{Cable Loss}_{[dB]}$
- o $\text{Margin}_{[dB]} = \text{Field Strength Level}_{[dB_{\mu V/m}]} - \text{Limit}_{[dB_{\mu V/m}]}$

Radiated Band Edge Measurement Offset

- o The amplitude offset shown in the radiated restricted band edge plots in Section 7.7 was calculated using the formula:

$$\text{Offset (dB)} = (\text{Antenna Factor} + \text{Cable Loss} + \text{Attenuator}) - \text{Preamplifier Gain}$$

FCC ID: A3LETWV531		FCC Pt. 15.247 802.11b/g/n/ac MEASUREMENT REPORT (CERTIFICATION)		Approved by: Quality Manager
Test Report S/N: 1M1705180171-02.A3L	Test Dates: 11/23/2016-02/17/2017	EUT Type: Indoor Access Point	Page 110 of 196	

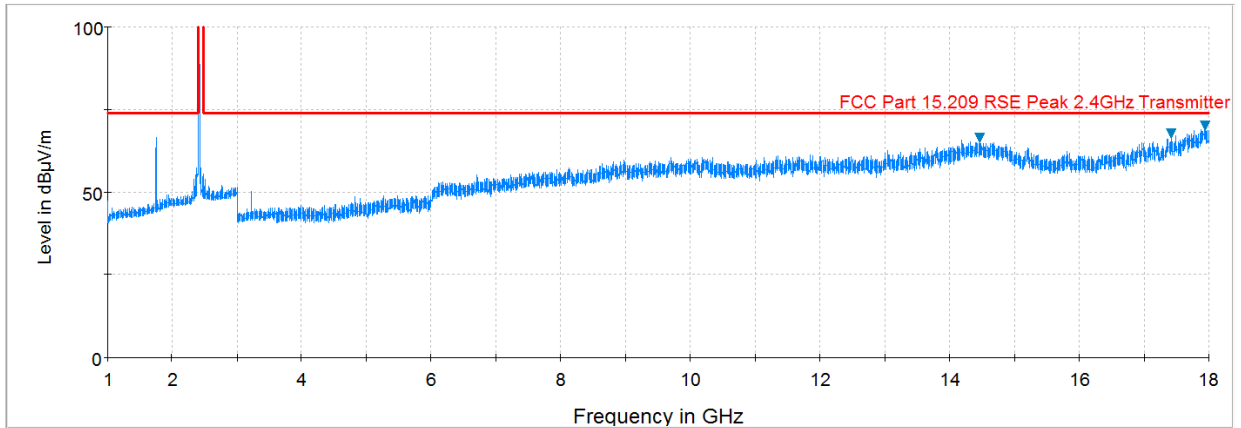

7.7.1 Antenna-1 Radiated Spurious Emission Measurements (20MHz BW) §15.247(d) §15.205 & §15.209

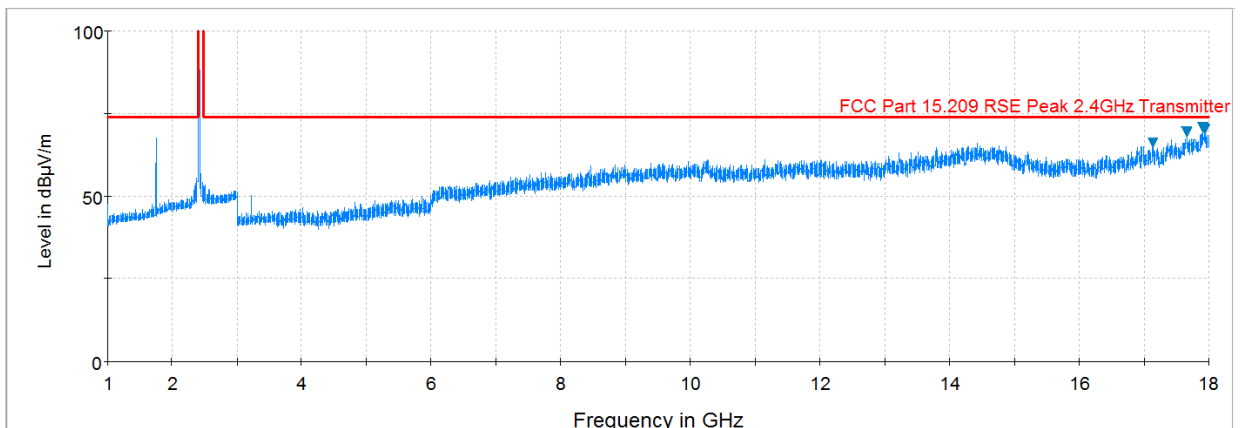

Plot 7-153. Radiated Spurious Plot above 1GHz (802.11b – Ch. 1, Ant. Pol. H)



Plot 7-154. Radiated Spurious Plot above 1GHz (802.11b – Ch. 1, Ant. Pol. V)

FCC ID: A3LETWV531		FCC Pt. 15.247 802.11b/g/n/ac MEASUREMENT REPORT (CERTIFICATION)		Approved by: Quality Manager
Test Report S/N: 1M1705180171-02.A3L	Test Dates: 11/23/2016-02/17/2017	EUT Type: Indoor Access Point	Page 111 of 196	

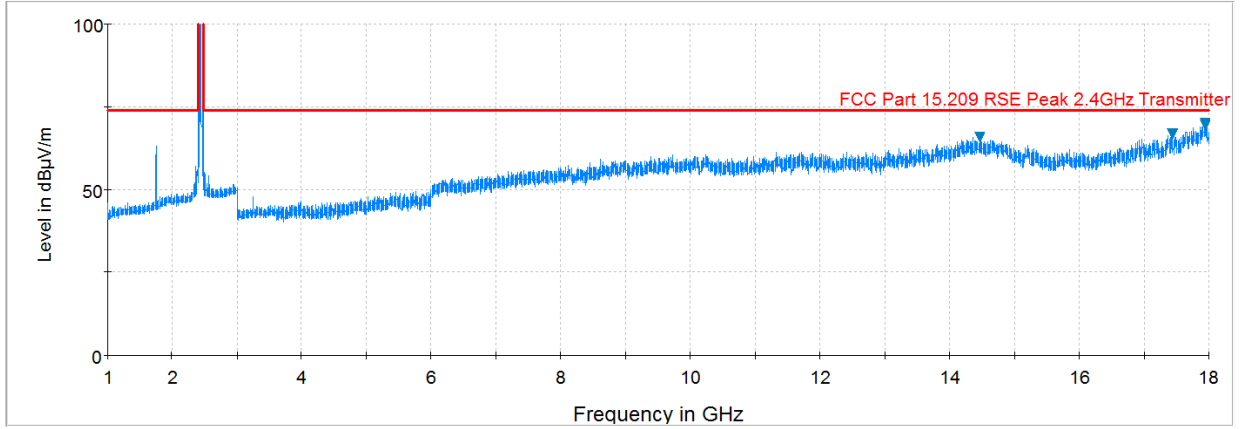

Plot 7-155. Radiated Spurious Plot above 1GHz (802.11b – Ch. 6, Ant. Pol. H)

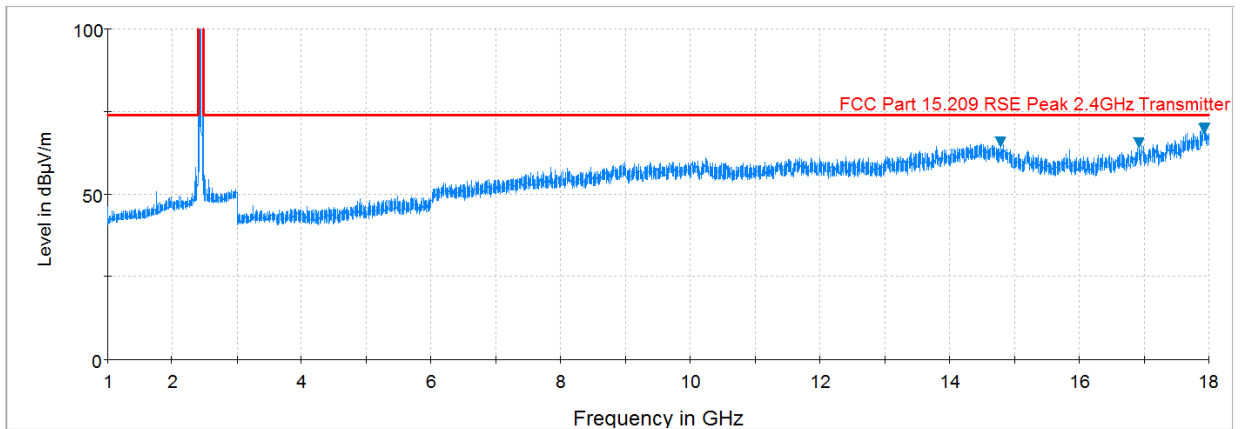

Plot 7-156. Radiated Spurious Plot above 1GHz (802.11b – Ch. 6, Ant. Pol. V)

FCC ID: A3LETWV531		FCC Pt. 15.247 802.11b/g/n/ac MEASUREMENT REPORT (CERTIFICATION)		Approved by: Quality Manager
Test Report S/N: 1M1705180171-02.A3L	Test Dates: 11/23/2016-02/17/2017	EUT Type: Indoor Access Point	Page 112 of 196	

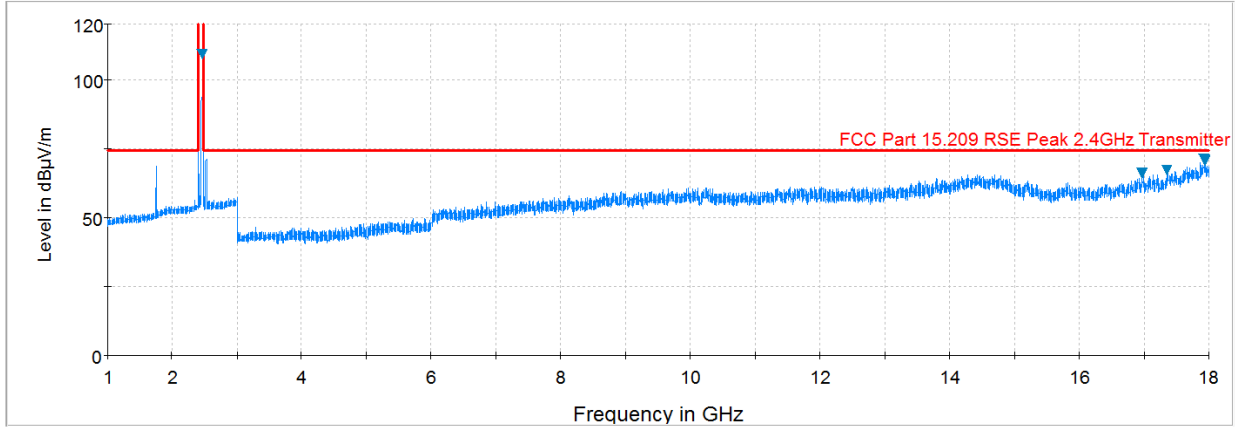

Plot 7-157. Radiated Spurious Plot above 1GHz (802.11b – Ch. 11, Ant. Pol. H)

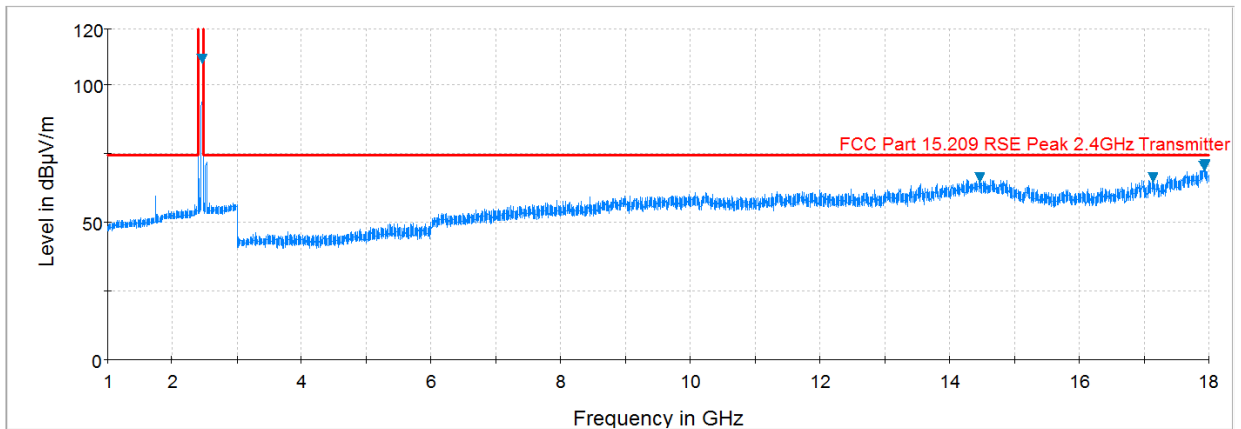

Plot 7-158. Radiated Spurious Plot above 1GHz (802.11b – Ch. 11, Ant. Pol. V)

FCC ID: A3LETWV531		FCC Pt. 15.247 802.11b/g/n/ac MEASUREMENT REPORT (CERTIFICATION)		Approved by: Quality Manager
Test Report S/N: 1M1705180171-02.A3L	Test Dates: 11/23/2016-02/17/2017	EUT Type: Indoor Access Point	Page 113 of 196	

Antenna-1 Radiated Spurious Emissions Measurements (Above 18GHz) §15.209

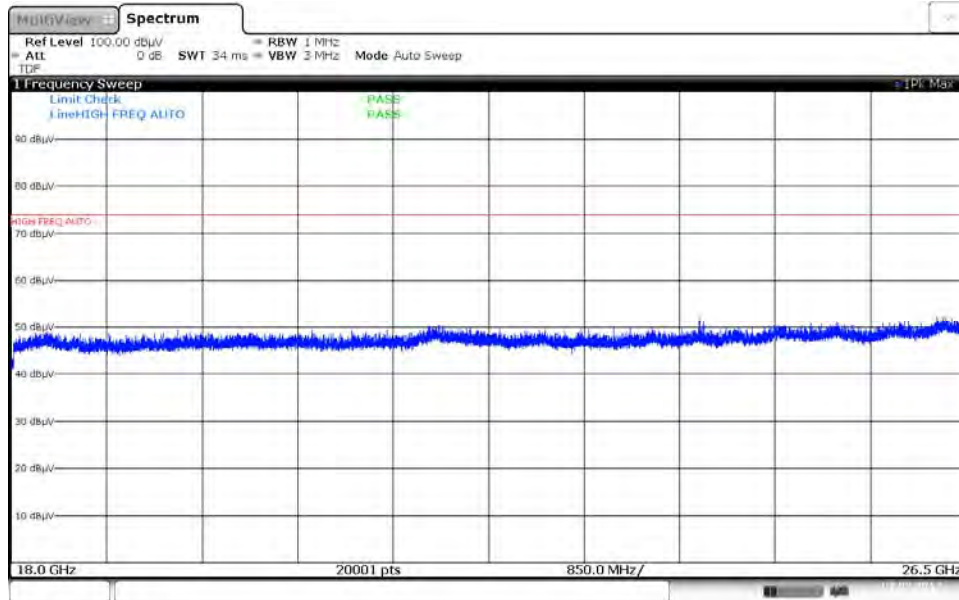

13:43:55 07.02.2017

Plot 7-159. Radiated Spurious Plot above 18GHz (Pol. H)

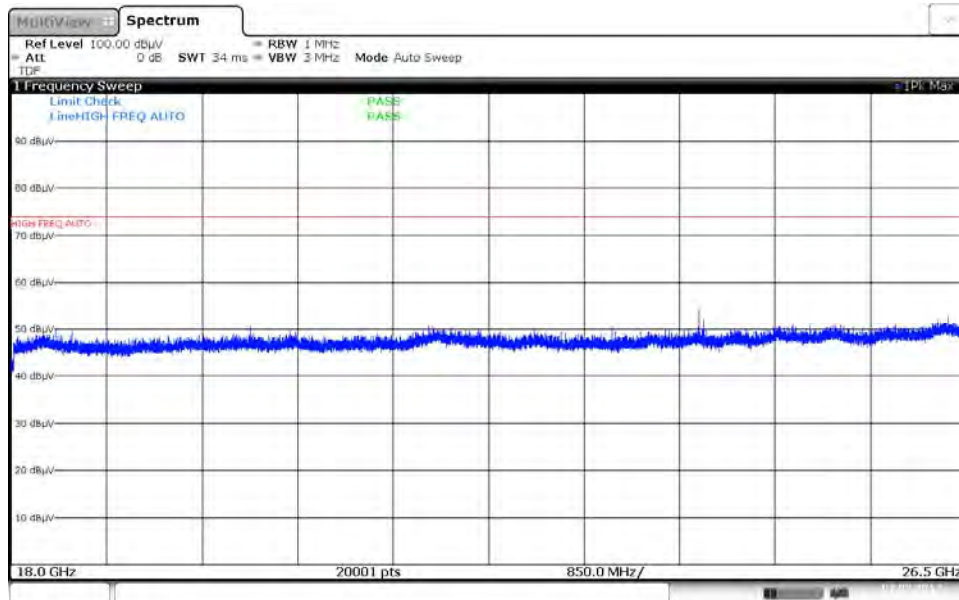

13:45:40 07.02.2017

Plot 7-160. Radiated Spurious Plot above 18GHz (Pol. V)

FCC ID: A3LETWV531		FCC Pt. 15.247 802.11b/g/n/ac MEASUREMENT REPORT (CERTIFICATION)		Approved by: Quality Manager
Test Report S/N: 1M1705180171-02.A3L	Test Dates: 11/23/2016-02/17/2017	EUT Type: Indoor Access Point		Page 114 of 196

Antenna-1 Radiated Spurious Emission Measurements (20MHz BW)

§15.247(d) §15.205 & §15.209

Worst Case Mode: 802.11b
 Worst Case Transfer Rate: 1 Mbps
 Distance of Measurements: 3 Meters
 Operating Frequency: 2412MHz
 Channel: 01



Frequency [MHz]	Detector	Ant. Pol. [H/V]	Antenna Height [cm]	Turntable Azimuth [degree]	Analyzer Level [dBm]	AFCL [dB/m]	Field Strength [dBµV/m]	Limit [dBµV/m]	Margin [dB]
4824.00	Avg	H	122	238	-66.38	0.55	41.17	53.98	-12.81
4824.00	Peak	H	122	238	-56.64	0.55	50.91	73.98	-23.07
12060.00	Avg	H	-	-	-71.15	14.41	50.26	53.98	-3.72
12060.00	Peak	H	-	-	-58.47	14.41	62.94	73.98	-11.04

Table 7-26. Radiated Measurements

Worst Case Mode: 802.11b
 Worst Case Transfer Rate: 1 Mbps
 Distance of Measurements: 3 Meters
 Operating Frequency: 2437MHz
 Channel: 06

Frequency [MHz]	Detector	Ant. Pol. [H/V]	Antenna Height [cm]	Turntable Azimuth [degree]	Analyzer Level [dBm]	AFCL [dB/m]	Field Strength [dBµV/m]	Limit [dBµV/m]	Margin [dB]
4874.00	Avg	H	184	228	-64.87	0.75	42.88	53.98	-11.10
4874.00	Peak	H	184	228	-55.88	0.75	51.87	73.98	-22.11
7311.00	Avg	H	-	-	-69.45	9.57	47.12	53.98	-6.86
7311.00	Peak	H	-	-	-57.24	9.57	59.33	73.98	-14.65
12185.00	Avg	H	-	-	-72.27	15.57	50.30	53.98	-3.68
12185.00	Peak	H	-	-	-57.21	15.57	65.36	73.98	-8.62



Table 7-27. Radiated Measurements

FCC ID: A3LETWV531		FCC Pt. 15.247 802.11b/g/n/ac MEASUREMENT REPORT (CERTIFICATION)		Approved by: Quality Manager
Test Report S/N: 1M1705180171-02.A3L	Test Dates: 11/23/2016-02/17/2017	EUT Type: Indoor Access Point	Page 115 of 196	

Worst Case Mode: 802.11b
 Worst Case Transfer Rate: 1 Mbps
 Distance of Measurements: 3 Meters
 Operating Frequency: 2462MHz
 Channel: 11

Frequency [MHz]	Detector	Ant. Pol. [H/V]	Antenna Height [cm]	Turntable Azimuth [degree]	Analyzer Level [dBm]	AFCL [dB/m]	Field Strength [dBμV/m]	Limit [dBμV/m]	Margin [dB]
4924.00	Avg	H	110	220	-65.55	0.96	42.41	53.98	-11.57
4924.00	Peak	H	110	220	-56.53	0.96	51.43	73.98	-22.55
7386.00	Avg	H	-	-	-68.97	10.35	48.38	53.98	-5.60
7386.00	Peak	H	-	-	-57.45	10.35	59.90	73.98	-14.08
12310.00	Avg	H	-	-	-72.02	15.20	50.18	53.98	-3.80
12310.00	Peak	H	-	-	-57.22	15.20	64.98	73.98	-9.00

Table 7-28. Radiated Measurements

FCC ID: A3LETWV531		FCC Pt. 15.247 802.11b/g/n/ac MEASUREMENT REPORT (CERTIFICATION)		Approved by: Quality Manager
Test Report S/N: 1M1705180171-02.A3L	Test Dates: 11/23/2016-02/17/2017	EUT Type: Indoor Access Point	Page 116 of 196	

7.7.2 Antenna-2 Radiated Spurious Emission Measurements (20MHz BW) §15.247(d) §15.205 & §15.209

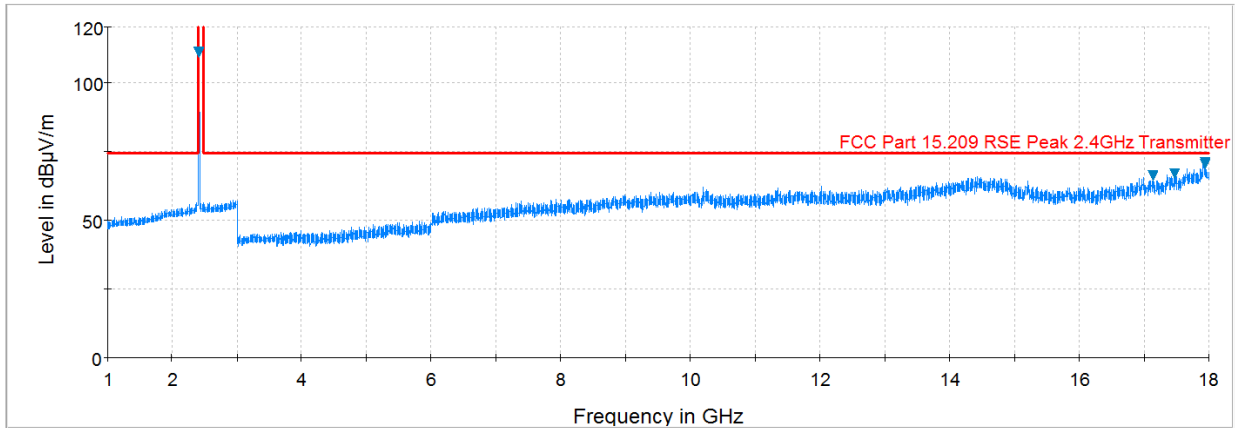

Plot 7-161. Radiated Spurious Plot above 1GHz (802.11b – Ch. 1, Ant. Pol. H)

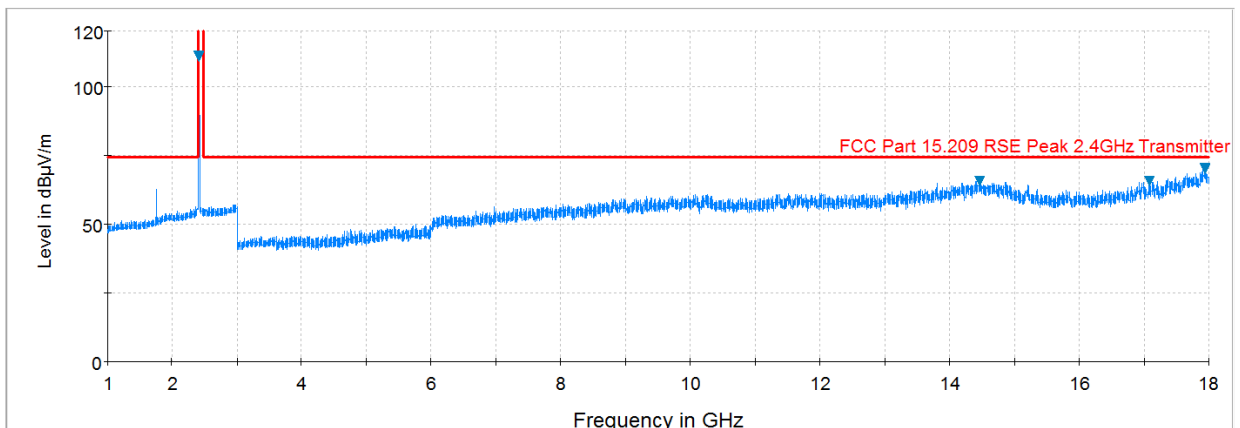

Plot 7-162. Radiated Spurious Plot above 1GHz (802.11b – Ch. 1, Ant. Pol. V)

FCC ID: A3LETWV531		FCC Pt. 15.247 802.11b/g/n/ac MEASUREMENT REPORT (CERTIFICATION)		Approved by: Quality Manager
Test Report S/N: 1M1705180171-02.A3L	Test Dates: 11/23/2016-02/17/2017	EUT Type: Indoor Access Point		Page 117 of 196

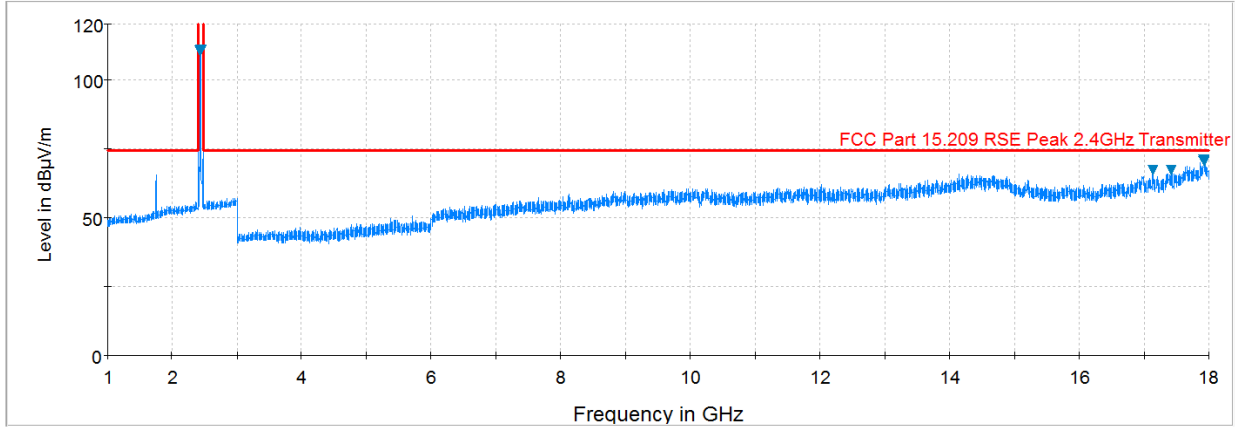

Plot 7-163. Radiated Spurious Plot above 1GHz (802.11b – Ch. 6, Ant. Pol. H)

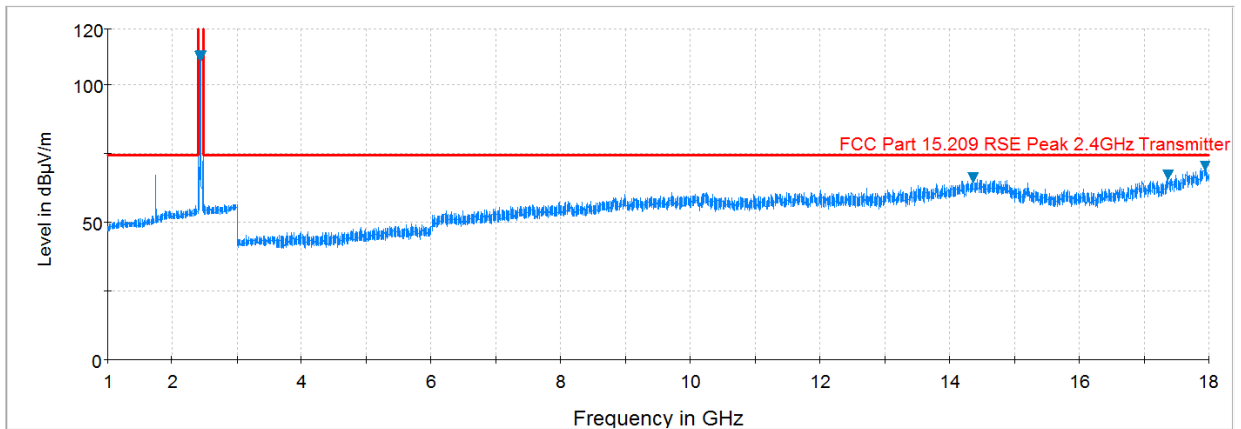

Plot 7-164. Radiated Spurious Plot above 1GHz (802.11b – Ch. 6, Ant. Pol. V)

FCC ID: A3LETWV531		FCC Pt. 15.247 802.11b/g/n/ac MEASUREMENT REPORT (CERTIFICATION)		Approved by: Quality Manager
Test Report S/N: 1M1705180171-02.A3L	Test Dates: 11/23/2016-02/17/2017	EUT Type: Indoor Access Point	Page 118 of 196	

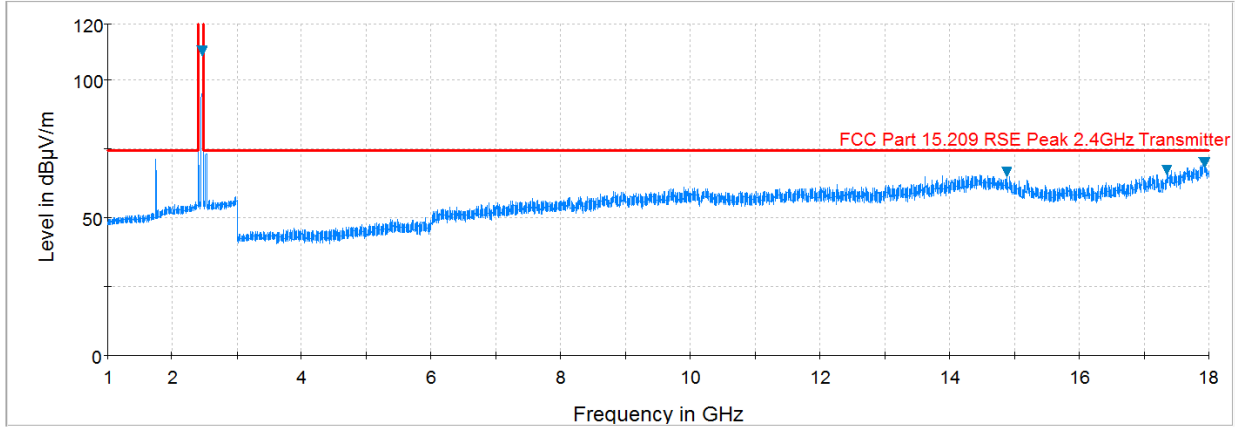

Preview Result 1-PK+ FCC Part 15.209 RSE Peak 2.4GHz Transmitter Final_Result PK+

Plot 7-165. Radiated Spurious Plot above 1GHz (802.11b – Ch. 11, Ant. Pol. H)

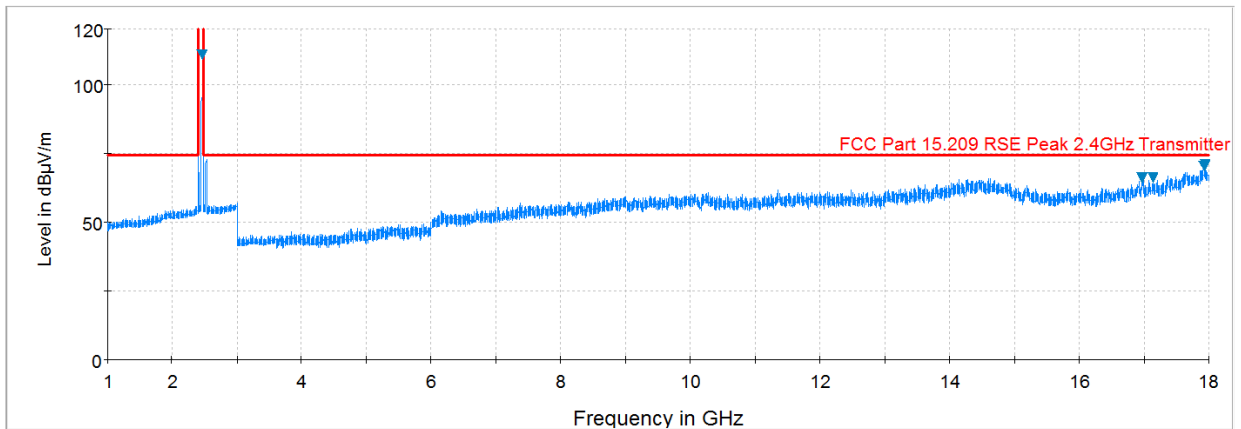

Preview Result 1-PK+ FCC Part 15.209 RSE Peak 2.4GHz Transmitter Final_Result PK+

Plot 7-166. Radiated Spurious Plot above 1GHz (802.11b – Ch. 11, Ant. Pol. V)

FCC ID: A3LETWV531		FCC Pt. 15.247 802.11b/g/n/ac MEASUREMENT REPORT (CERTIFICATION)		Approved by: Quality Manager
Test Report S/N: 1M1705180171-02.A3L	Test Dates: 11/23/2016-02/17/2017	EUT Type: Indoor Access Point	Page 119 of 196	

Antenna-2 Radiated Spurious Emissions Measurements (Above 18GHz) §15.209

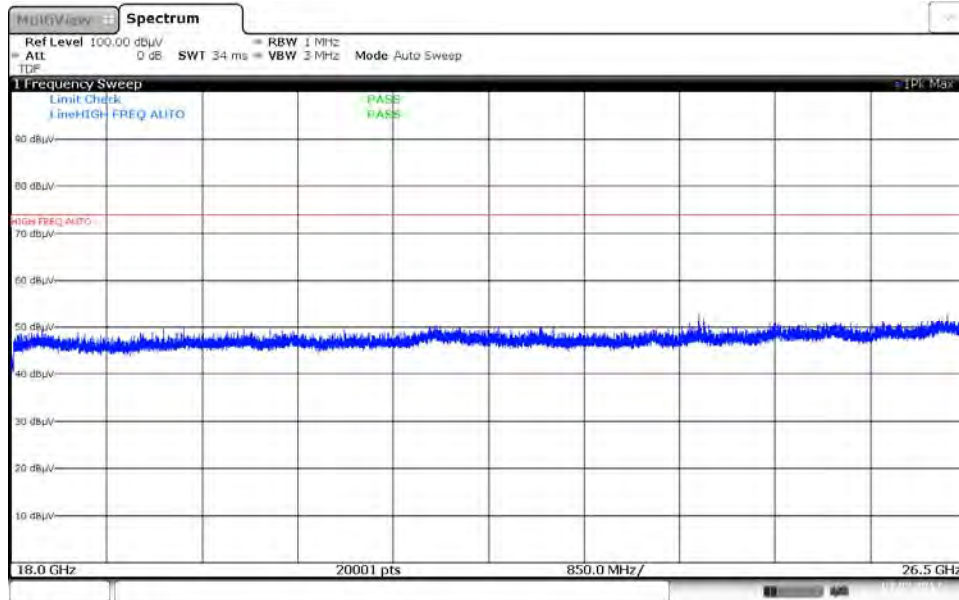

13:51:09 07.02.2017

Plot 7-167. Radiated Spurious Plot above 18GHz (Pol. H)

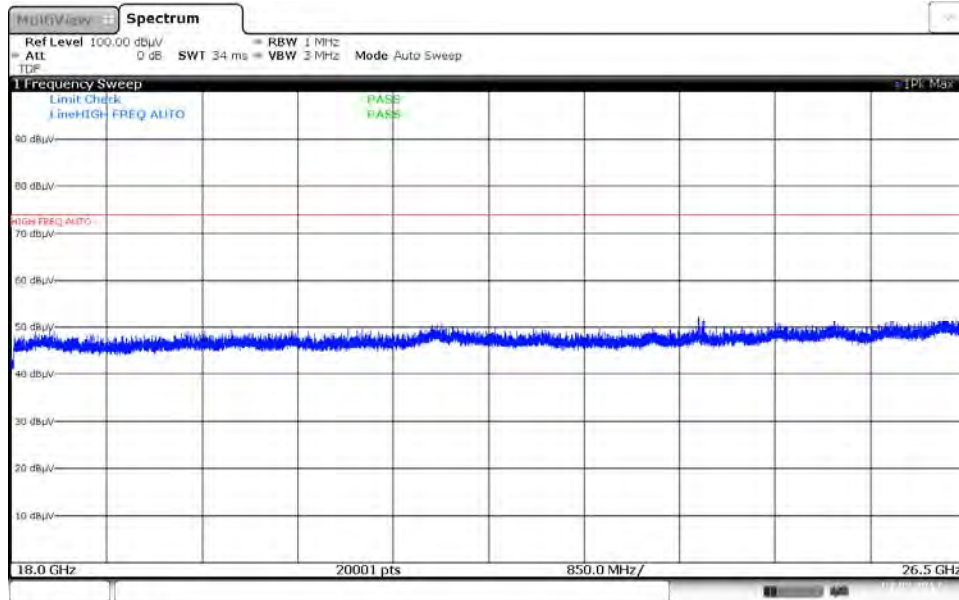

13:52:39 07.02.2017

Plot 7-168. Radiated Spurious Plot above 18GHz (Pol. V)

FCC ID: A3LETWV531		FCC Pt. 15.247 802.11b/g/n/ac MEASUREMENT REPORT (CERTIFICATION)		Approved by: Quality Manager
Test Report S/N: 1M1705180171-02.A3L	Test Dates: 11/23/2016-02/17/2017	EUT Type: Indoor Access Point	Page 120 of 196	

Antenna-2 Radiated Spurious Emission Measurements (20MHz BW)

§15.247(d) §15.205 & §15.209

Worst Case Mode: 802.11b
 Worst Case Transfer Rate: 1 Mbps
 Distance of Measurements: 3 Meters
 Operating Frequency: 2412MHz
 Channel: 01



Frequency [MHz]	Detector	Ant. Pol. [H/V]	Antenna Height [cm]	Turntable Azimuth [degree]	Analyzer Level [dBm]	AFCL [dB/m]	Field Strength [dBμV/m]	Limit [dBμV/m]	Margin [dB]
4824.00	Avg	H	110	257	-63.26	0.55	44.29	53.98	-9.69
4824.00	Peak	H	110	257	-55.54	0.55	52.01	73.98	-21.97
12060.00	Avg	H	-	-	-70.98	14.41	50.43	53.98	-3.55
12060.00	Peak	H	-	-	-58.19	14.41	63.22	73.98	-10.76

Table 7-29. Radiated Measurements

Worst Case Mode: 802.11b
 Worst Case Transfer Rate: 1 Mbps
 Distance of Measurements: 3 Meters
 Operating Frequency: 2437MHz
 Channel: 06

Frequency [MHz]	Detector	Ant. Pol. [H/V]	Antenna Height [cm]	Turntable Azimuth [degree]	Analyzer Level [dBm]	AFCL [dB/m]	Field Strength [dBμV/m]	Limit [dBμV/m]	Margin [dB]
4874.00	Avg	H	130	267	-65.03	0.75	42.72	53.98	-11.26
4874.00	Peak	H	130	267	-55.45	0.75	52.30	73.98	-21.68
7311.00	Avg	H	-	-	-68.94	9.57	47.63	53.98	-6.35
7311.00	Peak	H	-	-	-57.95	9.57	58.62	73.98	-15.36
12185.00	Avg	H	-	-	-71.72	15.57	50.85	53.98	-3.13
12185.00	Peak	H	-	-	-57.09	15.57	65.48	73.98	-8.50



Table 7-30. Radiated Measurements

FCC ID: A3LETWV531		FCC Pt. 15.247 802.11b/g/n/ac MEASUREMENT REPORT (CERTIFICATION)		Approved by: Quality Manager
Test Report S/N: 1M1705180171-02.A3L	Test Dates: 11/23/2016-02/17/2017	EUT Type: Indoor Access Point	Page 121 of 196	

Worst Case Mode: 802.11b
 Worst Case Transfer Rate: 1 Mbps
 Distance of Measurements: 3 Meters
 Operating Frequency: 2462MHz
 Channel: 11

Frequency [MHz]	Detector	Ant. Pol. [H/V]	Antenna Height [cm]	Turntable Azimuth [degree]	Analyzer Level [dBm]	AFCL [dB/m]	Field Strength [dBµV/m]	Limit [dBµV/m]	Margin [dB]
4924.00	Avg	H	124	256	-66.98	0.96	40.98	53.98	-13.00
4924.00	Peak	H	124	256	-58.01	0.96	49.95	73.98	-24.03
7386.00	Avg	H	-	-	-71.93	10.35	45.42	53.98	-8.56
7386.00	Peak	H	-	-	-60.46	10.35	56.89	73.98	-17.09
12310.00	Avg	H	-	-	-72.85	15.20	49.35	53.98	-4.63
12310.00	Peak	H	-	-	-60.69	15.20	61.51	73.98	-12.47

Table 7-31. Radiated Measurements

FCC ID: A3LETWV531		FCC Pt. 15.247 802.11b/g/n/ac MEASUREMENT REPORT (CERTIFICATION)		Approved by: Quality Manager
Test Report S/N: 1M1705180171-02.A3L	Test Dates: 11/23/2016-02/17/2017	EUT Type: Indoor Access Point	Page 122 of 196	

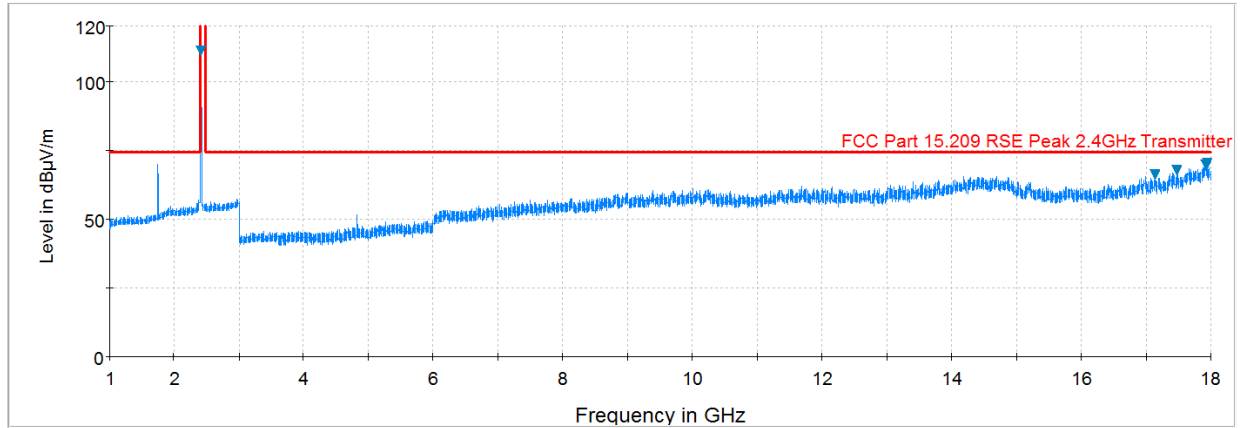

7.7.3 Antenna-3 Radiated Spurious Emission Measurements (20MHz BW) §15.247(d) §15.205 & §15.209

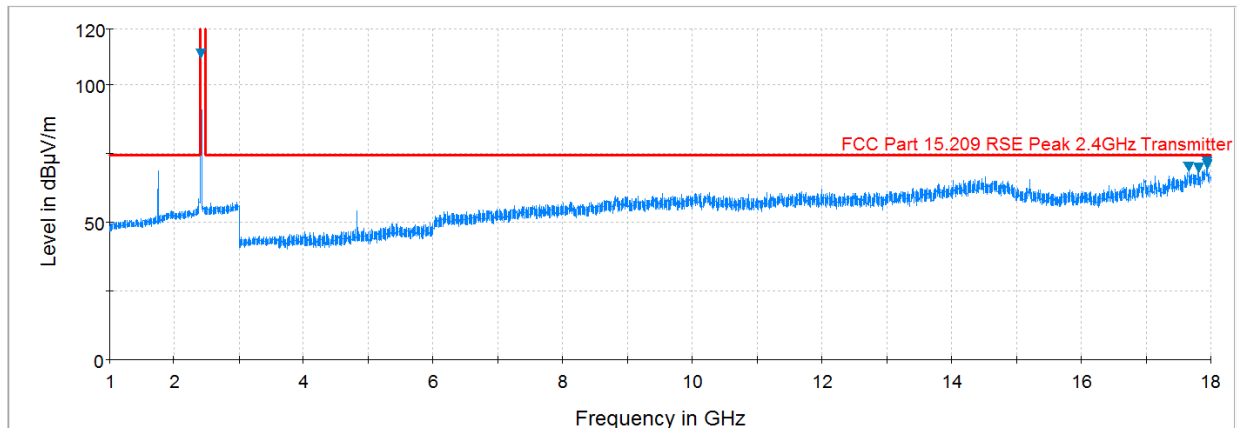

Plot 7-169. Radiated Spurious Plot above 1GHz (802.11b – Ch. 1, Ant. Pol. H)



Plot 7-170. Radiated Spurious Plot above 1GHz (802.11b – Ch. 1, Ant. Pol. V)

FCC ID: A3LETWV531		FCC Pt. 15.247 802.11b/g/n/ac MEASUREMENT REPORT (CERTIFICATION)		Approved by: Quality Manager
Test Report S/N: 1M1705180171-02.A3L	Test Dates: 11/23/2016-02/17/2017	EUT Type: Indoor Access Point	Page 123 of 196	

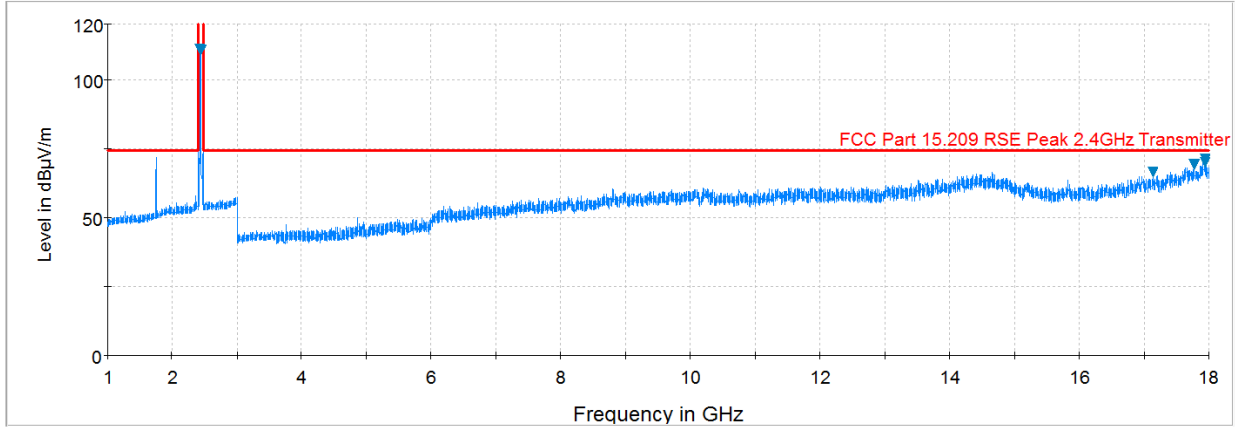

Plot 7-171. Radiated Spurious Plot above 1GHz (802.11b – Ch. 6, Ant. Pol. H)

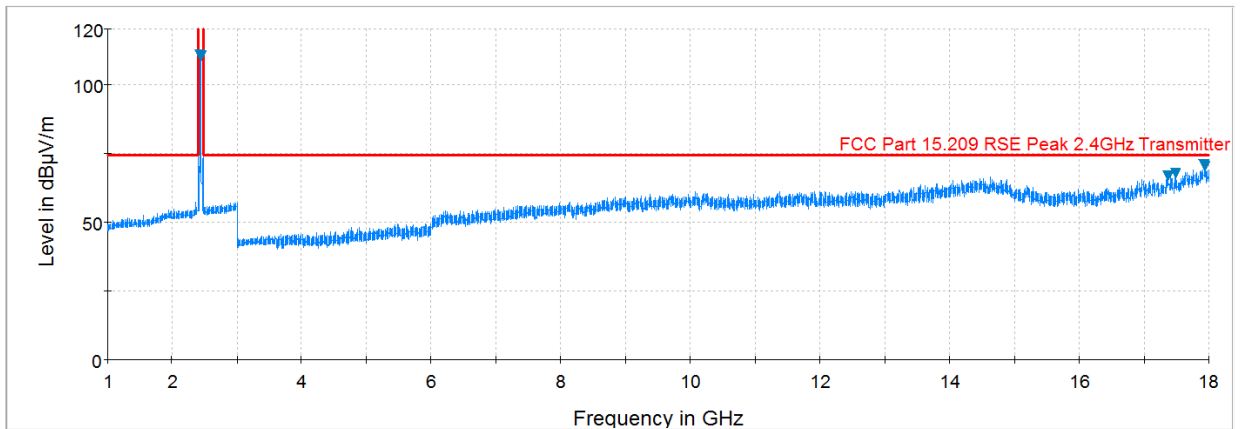

Plot 7-172. Radiated Spurious Plot above 1GHz (802.11b – Ch. 6, Ant. Pol. V)

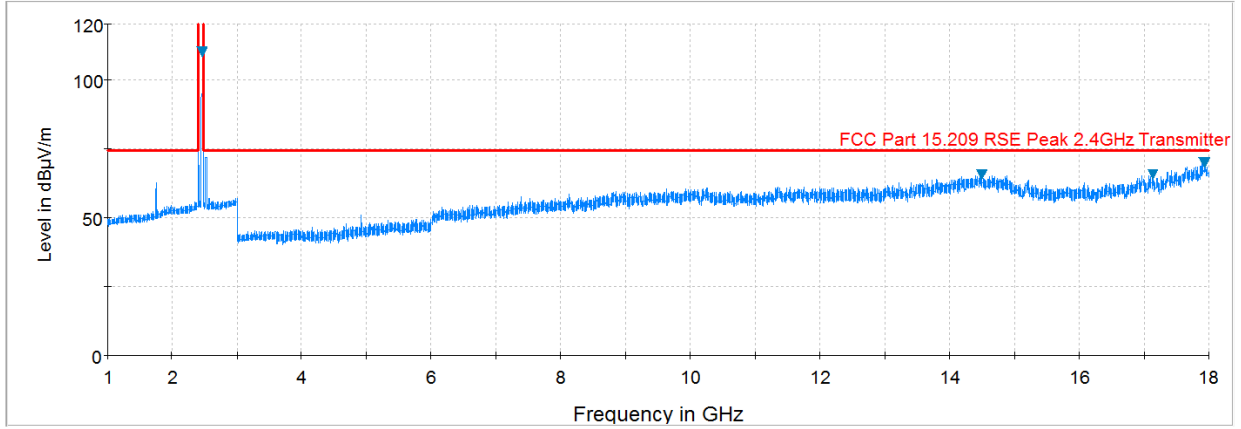

FCC ID: A3LETWV531		FCC Pt. 15.247 802.11b/g/n/ac MEASUREMENT REPORT (CERTIFICATION)		Approved by: Quality Manager
Test Report S/N: 1M1705180171-02.A3L	Test Dates: 11/23/2016-02/17/2017	EUT Type: Indoor Access Point	Page 124 of 196	

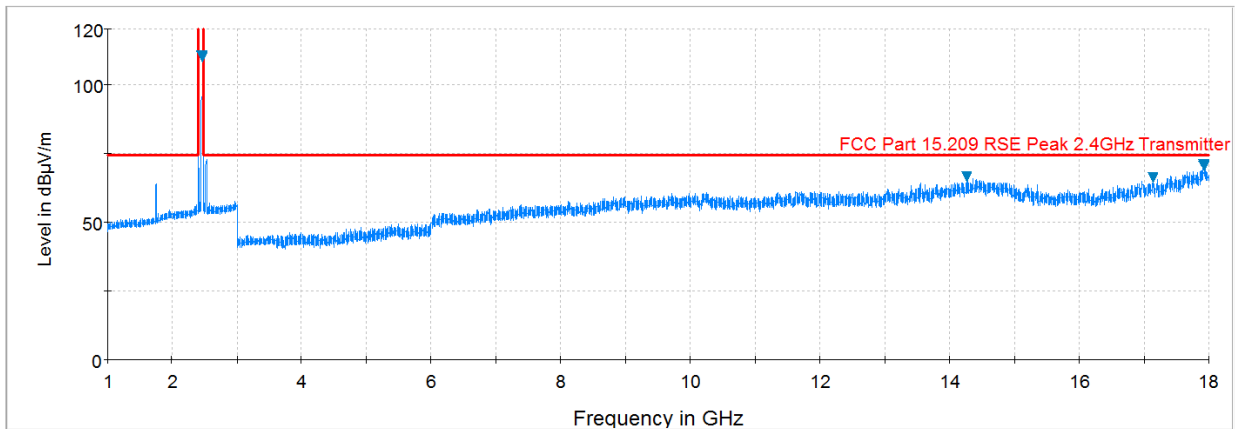

Plot 7-173. Radiated Spurious Plot above 1GHz (802.11b – Ch. 11, Ant. Pol. H)



Plot 7-174. Radiated Spurious Plot above 1GHz (802.11b – Ch. 11, Ant. Pol. V)

FCC ID: A3LETWV531		FCC Pt. 15.247 802.11b/g/n/ac MEASUREMENT REPORT (CERTIFICATION)		Approved by: Quality Manager
Test Report S/N: 1M1705180171-02.A3L	Test Dates: 11/23/2016-02/17/2017	EUT Type: Indoor Access Point	Page 125 of 196	

Antenna-3 Radiated Spurious Emissions Measurements (Above 18GHz) §15.209

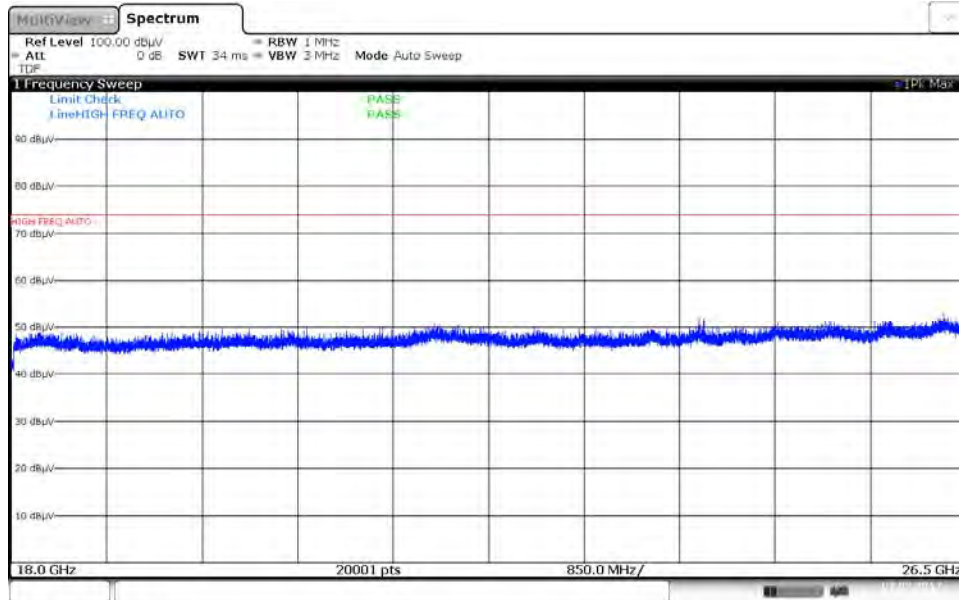

13:58:28 07.02.2017

Plot 7-175. Radiated Spurious Plot above 18GHz (Pol. H)

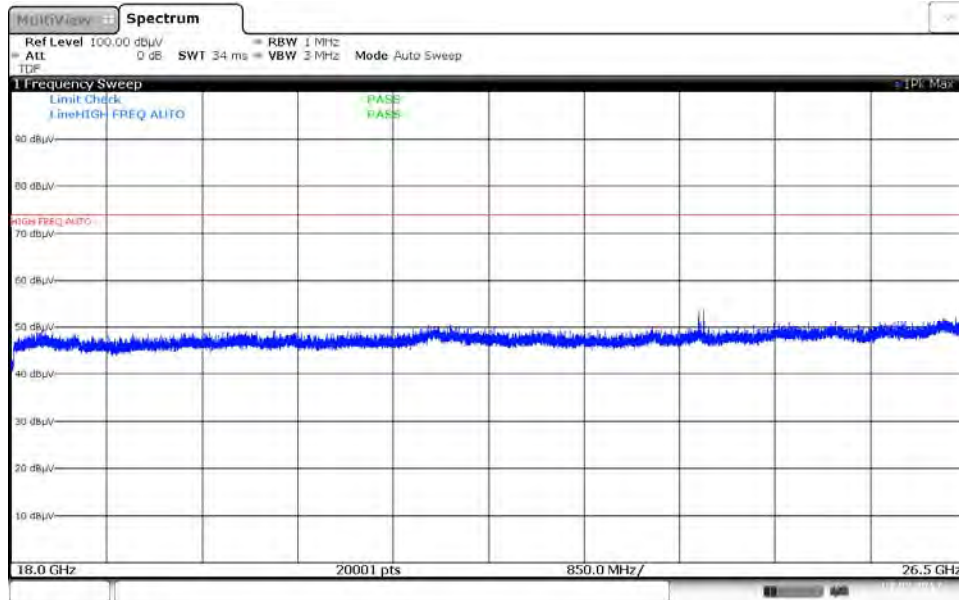

14:00:21 07.02.2017

Plot 7-176. Radiated Spurious Plot above 18GHz (Pol. V)

FCC ID: A3LETWV531		FCC Pt. 15.247 802.11b/g/n/ac MEASUREMENT REPORT (CERTIFICATION)		Approved by: Quality Manager
Test Report S/N: 1M1705180171-02.A3L	Test Dates: 11/23/2016-02/17/2017	EUT Type: Indoor Access Point		Page 126 of 196

Antenna-3 Radiated Spurious Emission Measurements (20MHz BW)

§15.247(d) §15.205 & §15.209

Worst Case Mode: 802.11b
 Worst Case Transfer Rate: 1 Mbps
 Distance of Measurements: 3 Meters
 Operating Frequency: 2412MHz
 Channel: 01



Frequency [MHz]	Detector	Ant. Pol. [H/V]	Antenna Height [cm]	Turntable Azimuth [degree]	Analyzer Level [dBm]	AFCL [dB/m]	Field Strength [dBµV/m]	Limit [dBµV/m]	Margin [dB]
4824.00	Avg	H	195	342	-56.78	0.55	50.77	53.98	-3.21
4824.00	Peak	H	195	342	-47.90	0.55	59.65	73.98	-14.33
12060.00	Avg	H	-	-	-72.71	14.41	48.70	53.98	-5.28
12060.00	Peak	H	-	-	-57.85	14.41	63.56	73.98	-10.42

Table 7-32. Radiated Measurements

Worst Case Mode: 802.11b
 Worst Case Transfer Rate: 1 Mbps
 Distance of Measurements: 3 Meters
 Operating Frequency: 2437MHz
 Channel: 06

Frequency [MHz]	Detector	Ant. Pol. [H/V]	Antenna Height [cm]	Turntable Azimuth [degree]	Analyzer Level [dBm]	AFCL [dB/m]	Field Strength [dBµV/m]	Limit [dBµV/m]	Margin [dB]
4874.00	Avg	H	115	208	-57.63	0.75	50.12	53.98	-3.86
4874.00	Peak	H	115	208	-51.53	0.75	56.22	73.98	-17.76
7311.00	Avg	H	-	-	-71.45	9.57	45.12	53.98	-8.86
7311.00	Peak	H	-	-	-60.60	9.57	55.97	73.98	-18.01
12185.00	Avg	H	-	-	-71.59	15.57	50.98	53.98	-3.00
12185.00	Peak	H	-	-	-59.64	15.57	62.93	73.98	-11.05



Table 7-33. Radiated Measurements

FCC ID: A3LETWV531		FCC Pt. 15.247 802.11b/g/n/ac MEASUREMENT REPORT (CERTIFICATION)		Approved by: Quality Manager
Test Report S/N: 1M1705180171-02.A3L	Test Dates: 11/23/2016-02/17/2017	EUT Type: Indoor Access Point	Page 127 of 196	

Worst Case Mode: 802.11b
 Worst Case Transfer Rate: 1 Mbps
 Distance of Measurements: 3 Meters
 Operating Frequency: 2462MHz
 Channel: 11

Frequency [MHz]	Detector	Ant. Pol. [H/V]	Antenna Height [cm]	Turntable Azimuth [degree]	Analyzer Level [dBm]	AFCL [dB/m]	Field Strength [dBμV/m]	Limit [dBμV/m]	Margin [dB]
4924.00	Avg	H	227	323	-67.05	0.96	40.91	53.98	-13.07
4924.00	Peak	H	227	323	-58.29	0.96	49.67	73.98	-24.31
7386.00	Avg	H	-	-	-71.34	10.35	46.01	53.98	-7.97
7386.00	Peak	H	-	-	-59.00	10.35	58.35	73.98	-15.63
12310.00	Avg	H	-	-	-71.37	15.20	50.83	53.98	-3.15
12310.00	Peak	H	-	-	-60.44	15.20	61.76	73.98	-12.22

Table 7-34. Radiated Measurements

FCC ID: A3LETWV531		FCC Pt. 15.247 802.11b/g/n/ac MEASUREMENT REPORT (CERTIFICATION)		Approved by: Quality Manager
Test Report S/N: 1M1705180171-02.A3L	Test Dates: 11/23/2016-02/17/2017	EUT Type: Indoor Access Point	Page 128 of 196	

7.7.4 Antenna-4 Radiated Spurious Emission Measurements (20MHz BW)

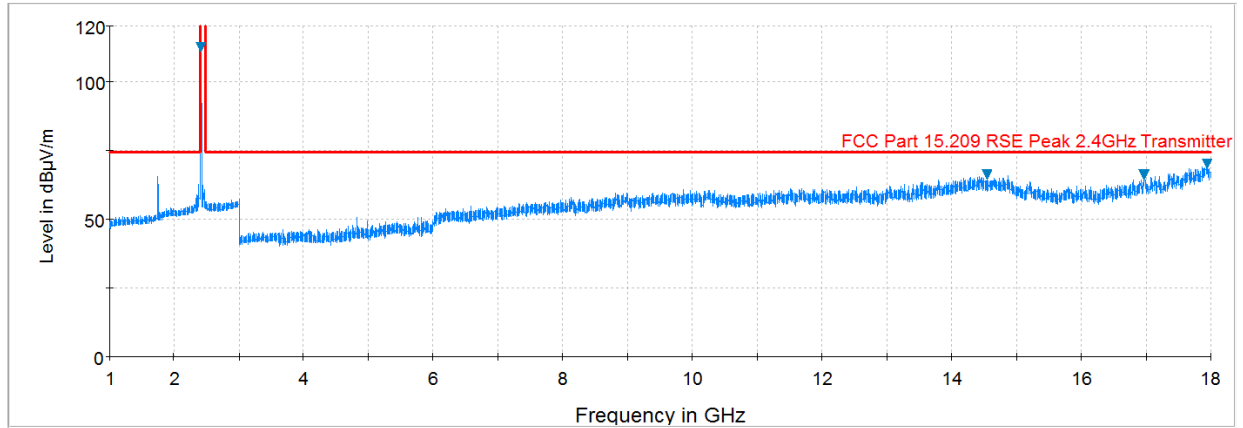

§15.247(d) §15.205 & §15.209

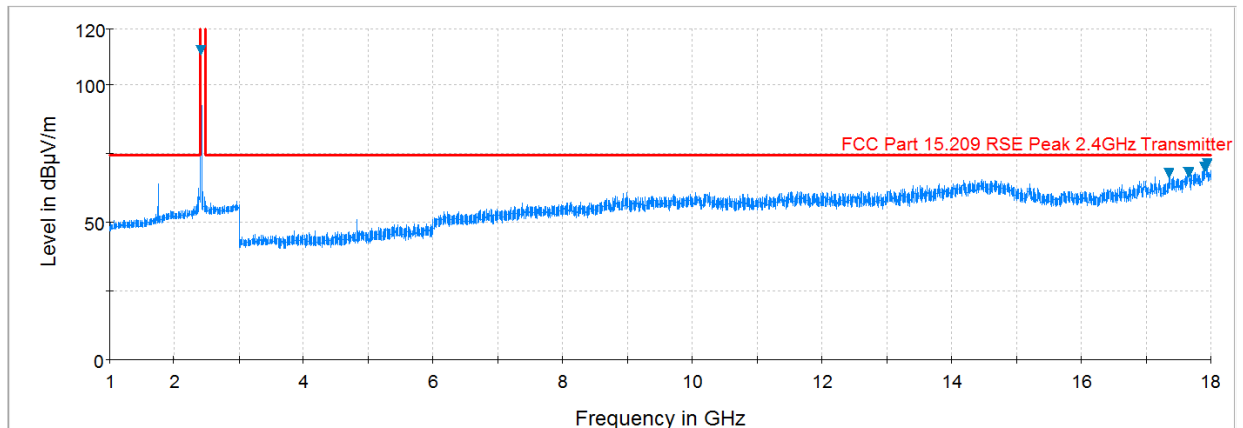

Plot 7-177. Radiated Spurious Plot above 1GHz (802.11b – Ch. 1, Ant. Pol. H)



Plot 7-178. Radiated Spurious Plot above 1GHz (802.11b – Ch. 1, Ant. Pol. V)

FCC ID: A3LETWV531		FCC Pt. 15.247 802.11b/g/n/ac MEASUREMENT REPORT (CERTIFICATION)		Approved by: Quality Manager
Test Report S/N: 1M1705180171-02.A3L	Test Dates: 11/23/2016-02/17/2017	EUT Type: Indoor Access Point		Page 129 of 196

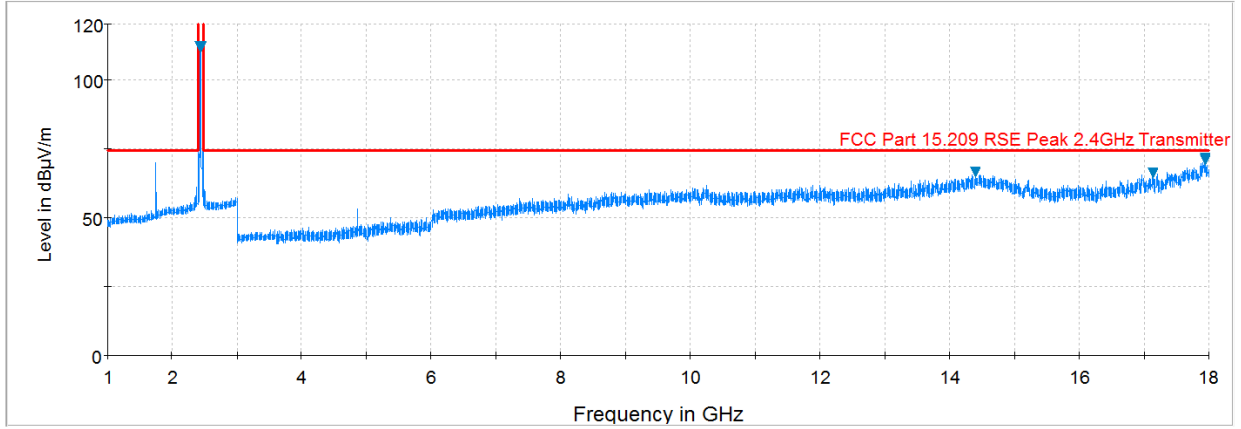

Preview Result 1-PK+ FCC Part 15.209 RSE Peak 2.4GHz Transmitter Final_Result PK+

Plot 7-179. Radiated Spurious Plot above 1GHz (802.11b – Ch. 6, Ant. Pol. H)

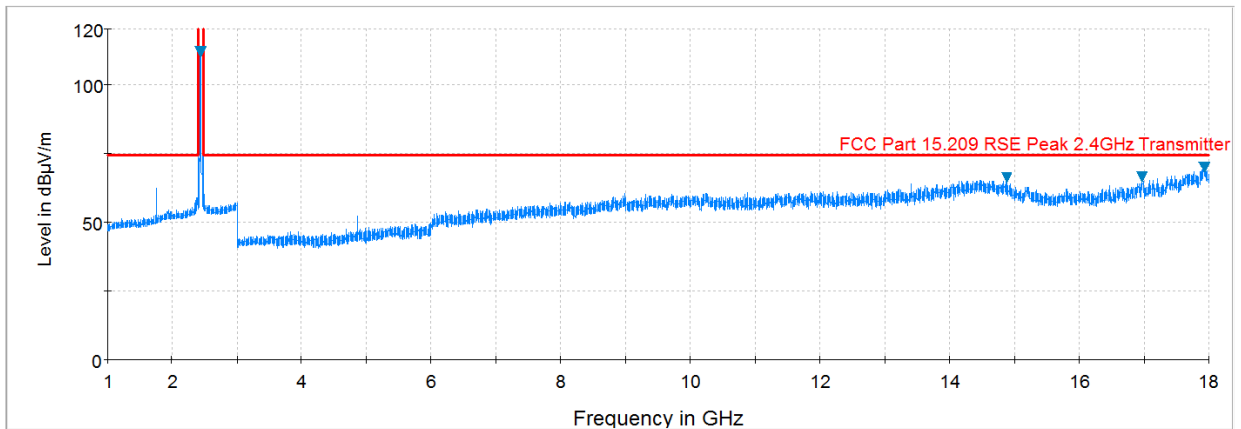

Preview Result 1-PK+ FCC Part 15.209 RSE Peak 2.4GHz Transmitter Final_Result PK+

Plot 7-180. Radiated Spurious Plot above 1GHz (802.11b – Ch. 6, Ant. Pol. V)

FCC ID: A3LETWV531		FCC Pt. 15.247 802.11b/g/n/ac MEASUREMENT REPORT (CERTIFICATION)		Approved by: Quality Manager
Test Report S/N: 1M1705180171-02.A3L	Test Dates: 11/23/2016-02/17/2017	EUT Type: Indoor Access Point	Page 130 of 196	

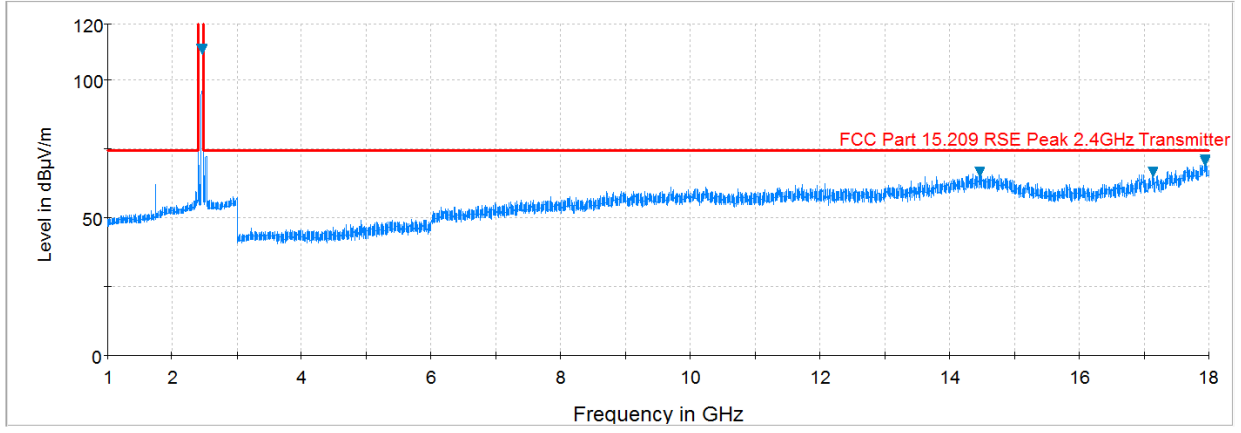

Plot 7-181. Radiated Spurious Plot above 1GHz (802.11b – Ch. 11, Ant. Pol. H)

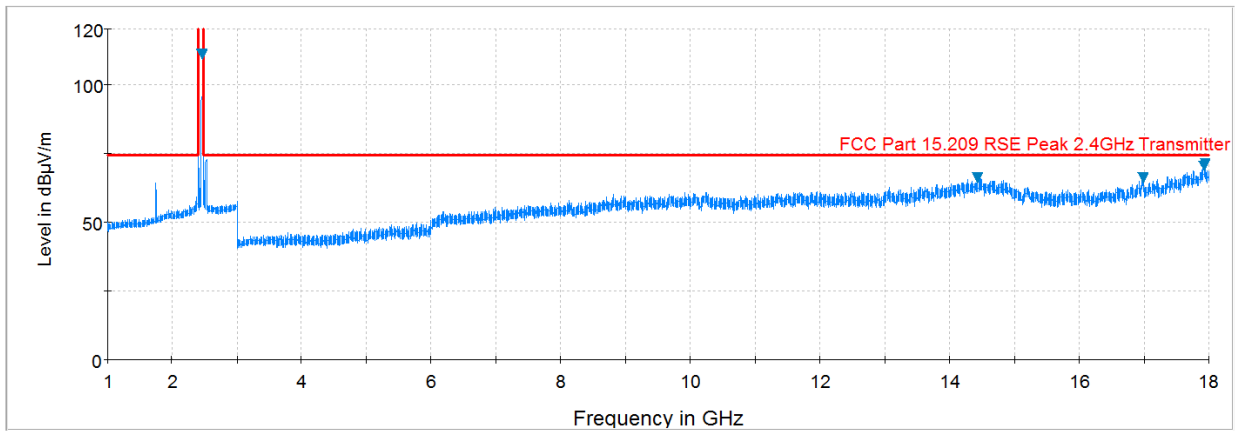

Plot 7-182. Radiated Spurious Plot above 1GHz (802.11b – Ch. 11, Ant. Pol. V)

FCC ID: A3LETWV531		FCC Pt. 15.247 802.11b/g/n/ac MEASUREMENT REPORT (CERTIFICATION)		Approved by: Quality Manager
Test Report S/N: 1M1705180171-02.A3L	Test Dates: 11/23/2016-02/17/2017	EUT Type: Indoor Access Point	Page 131 of 196	

Antenna-4 Radiated Spurious Emissions Measurements (Above 18GHz) §15.209

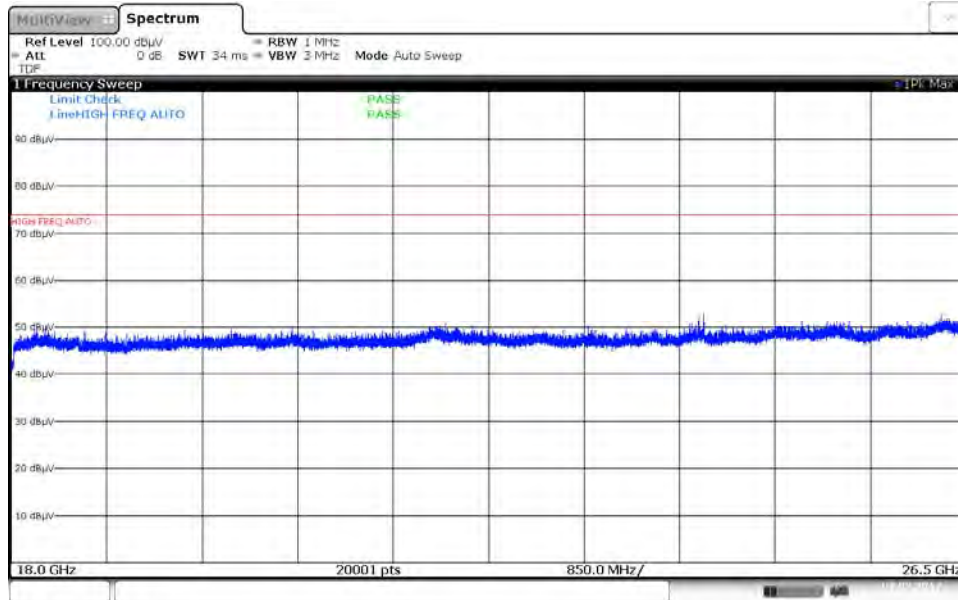

14:06:30 07.02.2017

Plot 7-183. Radiated Spurious Plot above 18GHz (Pol. H)

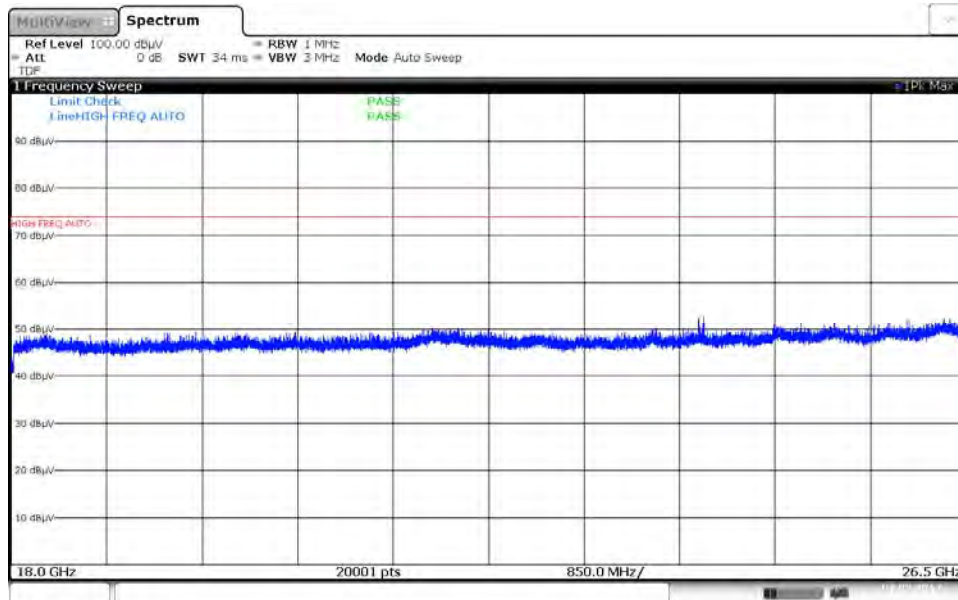

14:08:42 07.02.2017

Plot 7-184. Radiated Spurious Plot above 18GHz (Pol. V)

FCC ID: A3LETWV531		FCC Pt. 15.247 802.11b/g/n/ac MEASUREMENT REPORT (CERTIFICATION)		Approved by: Quality Manager
Test Report S/N: 1M1705180171-02.A3L	Test Dates: 11/23/2016-02/17/2017	EUT Type: Indoor Access Point		Page 132 of 196

Antenna-4 Radiated Spurious Emission Measurements (20MHz BW)

§15.247(d) §15.205 & §15.209

Worst Case Mode: 802.11b
 Worst Case Transfer Rate: 1 Mbps
 Distance of Measurements: 3 Meters
 Operating Frequency: 2412MHz
 Channel: 01



Frequency [MHz]	Detector	Ant. Pol. [H/V]	Antenna Height [cm]	Turntable Azimuth [degree]	Analyzer Level [dBm]	AFCL [dB/m]	Field Strength [dBµV/m]	Limit [dBµV/m]	Margin [dB]
4824.00	Avg	H	110	257	-63.26	0.55	44.29	53.98	-9.69
4824.00	Peak	H	110	257	-55.54	0.55	52.01	73.98	-21.97
12060.00	Avg	H	-	-	-70.98	14.41	50.43	53.98	-3.55
12060.00	Peak	H	-	-	-58.19	14.41	63.22	73.98	-10.76

Table 7-35. Radiated Measurements

Worst Case Mode: 802.11b
 Worst Case Transfer Rate: 1 Mbps
 Distance of Measurements: 3 Meters
 Operating Frequency: 2437MHz
 Channel: 06

Frequency [MHz]	Detector	Ant. Pol. [H/V]	Antenna Height [cm]	Turntable Azimuth [degree]	Analyzer Level [dBm]	AFCL [dB/m]	Field Strength [dBµV/m]	Limit [dBµV/m]	Margin [dB]
4874.00	Avg	H	130	267	-65.03	0.75	42.72	53.98	-11.26
4874.00	Peak	H	130	267	-55.45	0.75	52.30	73.98	-21.68
7311.00	Avg	H	-	-	-68.94	9.57	47.63	53.98	-6.35
7311.00	Peak	H	-	-	-57.95	9.57	58.62	73.98	-15.36
12185.00	Avg	H	-	-	-71.72	15.57	50.85	53.98	-3.13
12185.00	Peak	H	-	-	-57.09	15.57	65.48	73.98	-8.50



Table 7-36. Radiated Measurements

FCC ID: A3LETWV531		FCC Pt. 15.247 802.11b/g/n/ac MEASUREMENT REPORT (CERTIFICATION)		Approved by: Quality Manager
Test Report S/N: 1M1705180171-02.A3L	Test Dates: 11/23/2016-02/17/2017	EUT Type: Indoor Access Point	Page 133 of 196	

Worst Case Mode: 802.11b
 Worst Case Transfer Rate: 1 Mbps
 Distance of Measurements: 3 Meters
 Operating Frequency: 2462MHz
 Channel: 11

Frequency [MHz]	Detector	Ant. Pol. [H/V]	Antenna Height [cm]	Turntable Azimuth [degree]	Analyzer Level [dBm]	AFCL [dB/m]	Field Strength [dBµV/m]	Limit [dBµV/m]	Margin [dB]
4924.00	Avg	H	124	256	-66.98	0.96	40.98	53.98	-13.00
4924.00	Peak	H	124	256	-58.01	0.96	49.95	73.98	-24.03
7386.00	Avg	H	-	-	-71.93	10.35	45.42	53.98	-8.56
7386.00	Peak	H	-	-	-60.46	10.35	56.89	73.98	-17.09
12310.00	Avg	H	-	-	-72.85	15.20	49.35	53.98	-4.63
12310.00	Peak	H	-	-	-60.69	15.20	61.51	73.98	-12.47

Table 7-37. Radiated Measurements

FCC ID: A3LETWV531		FCC Pt. 15.247 802.11b/g/n/ac MEASUREMENT REPORT (CERTIFICATION)		Approved by: Quality Manager
Test Report S/N: 1M1705180171-02.A3L	Test Dates: 11/23/2016-02/17/2017	EUT Type: Indoor Access Point	Page 134 of 196	

7.7.5 Antenna-1 Radiated Restricted Band Edge Measurements §15.205 §15.209

The radiated restricted band edge measurements are measured with an EMI test receiver connected to the receive antenna while the EUT is transmitting.

Worst Case Mode: 802.11g
 Worst Case Transfer Rate: 6 Mbps
 Distance of Measurements: 3 Meters
 Operating Frequency: 2412MHz
 Channel: 1

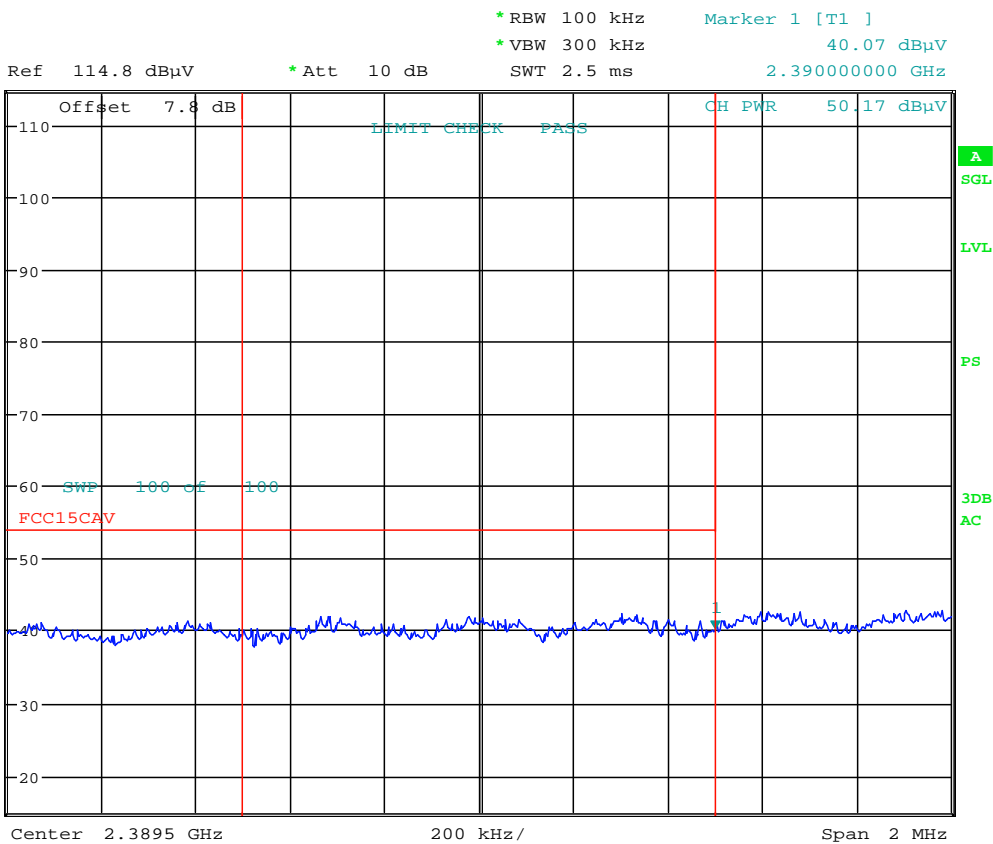

Date: 1.DEC.2016 10:05:17

Plot 7-185. Radiated Restricted Lower Band Edge Measurement (Average)

FCC ID: A3LETWV531		FCC Pt. 15.247 802.11b/g/n/ac MEASUREMENT REPORT (CERTIFICATION)		Approved by: Quality Manager
Test Report S/N: 1M1705180171-02.A3L	Test Dates: 11/23/2016-02/17/2017	EUT Type: Indoor Access Point	Page 135 of 196	

Antenna-1 Radiated Restricted Band Edge Measurements

§15.205 §15.209

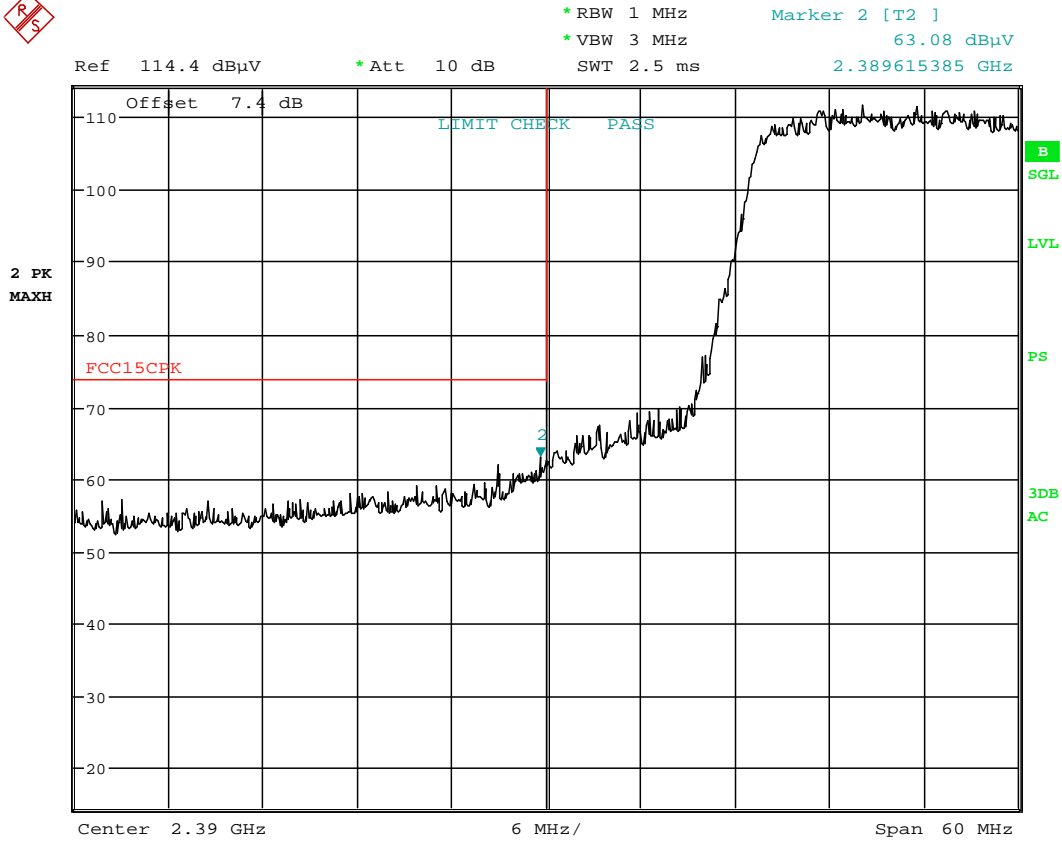

Date: 1.DEC.2016 10:07:27

Plot 7-186. Radiated Restricted Lower Band Edge Measurement (Peak)

FCC ID: A3LETWV531		FCC Pt. 15.247 802.11b/g/n/ac MEASUREMENT REPORT (CERTIFICATION)		Approved by: Quality Manager
Test Report S/N: 1M1705180171-02.A3L	Test Dates: 11/23/2016-02/17/2017	EUT Type: Indoor Access Point	Page 136 of 196	

Antenna-1 Radiated Restricted Band Edge Measurements §15.205 §15.209

The radiated restricted band edge measurements are measured with an EMI test receiver connected to the receive antenna while the EUT is transmitting.

Worst Case Mode: 802.11n/ac (40MHz BW)
 Worst Case Transfer Rate: MCS8
 Distance of Measurements: 3 Meters
 Operating Frequency: 2422MHz
 Channel: 3

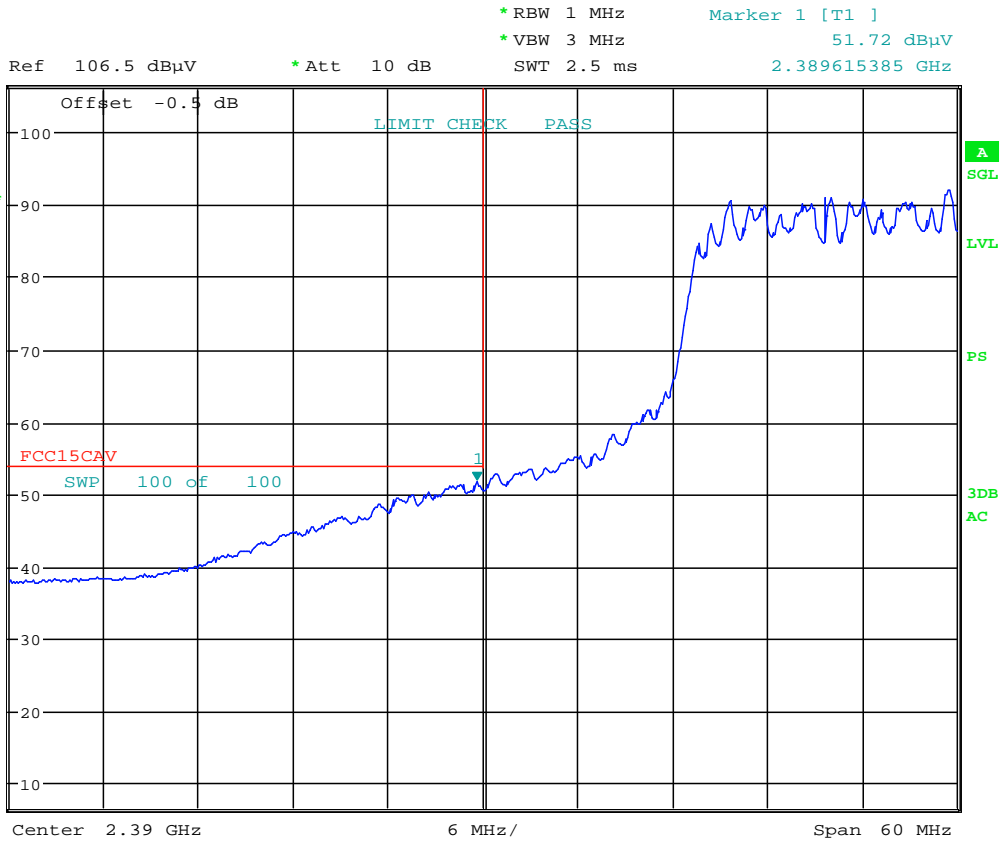

Date: 9.FEB.2017 17:13:41

Plot 7-187. Radiated Restricted Lower Band Edge Measurement (Average)

FCC ID: A3LETWV531		FCC Pt. 15.247 802.11b/g/n/ac MEASUREMENT REPORT (CERTIFICATION)		Approved by: Quality Manager
Test Report S/N: 1M1705180171-02.A3L	Test Dates: 11/23/2016-02/17/2017	EUT Type: Indoor Access Point		Page 137 of 196

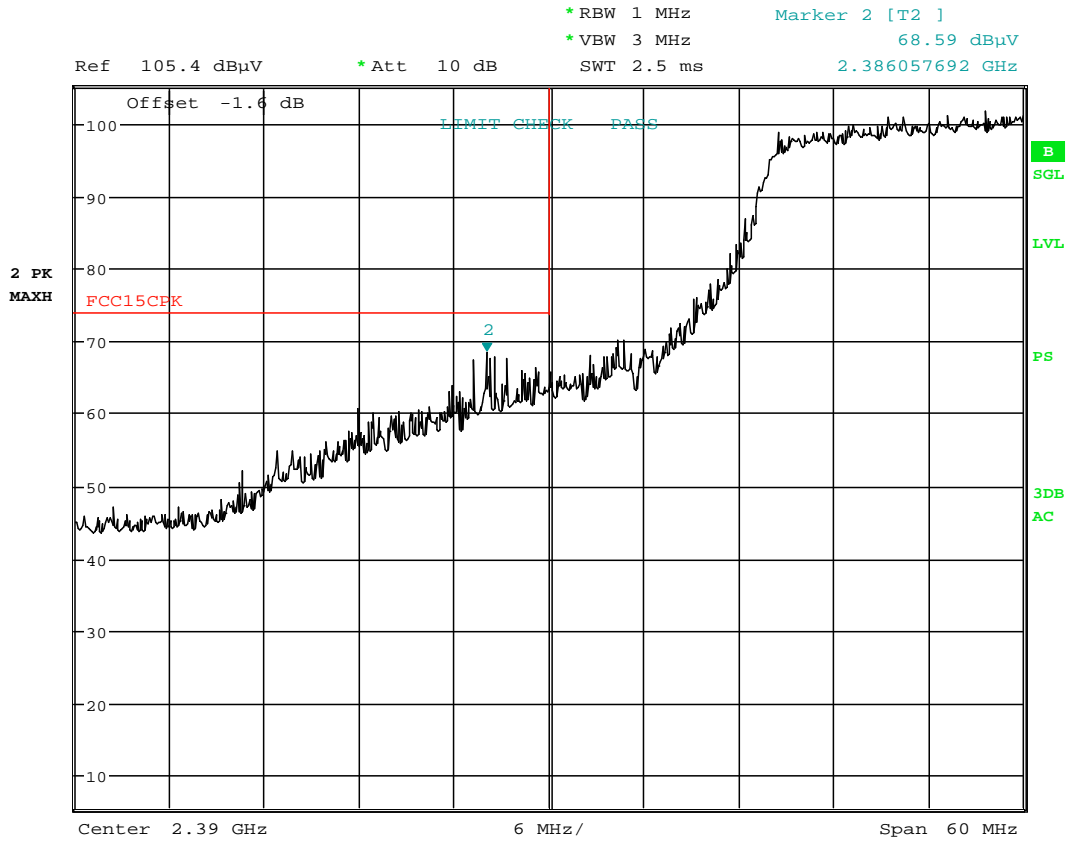

Antenna-1 Radiated Restricted Band Edge Measurements

§15.205 §15.209



Date: 17.FEB.2017 08:45:30

Plot 7-188. Radiated Restricted Lower Band Edge Measurement (Peak)

FCC ID: A3LETWV531		FCC Pt. 15.247 802.11b/g/n/ac MEASUREMENT REPORT (CERTIFICATION)		Approved by: Quality Manager
Test Report S/N: 1M1705180171-02.A3L	Test Dates: 11/23/2016-02/17/2017	EUT Type: Indoor Access Point	Page 138 of 196	

Antenna-1 Radiated Restricted Band Edge Measurements

§15.205 §15.209

Worst Case Mode: 802.11g

Worst Case Transfer Rate: 6 Mbps

Distance of Measurements: 3 Meters

Operating Frequency: 2462MHz

Channel: 11

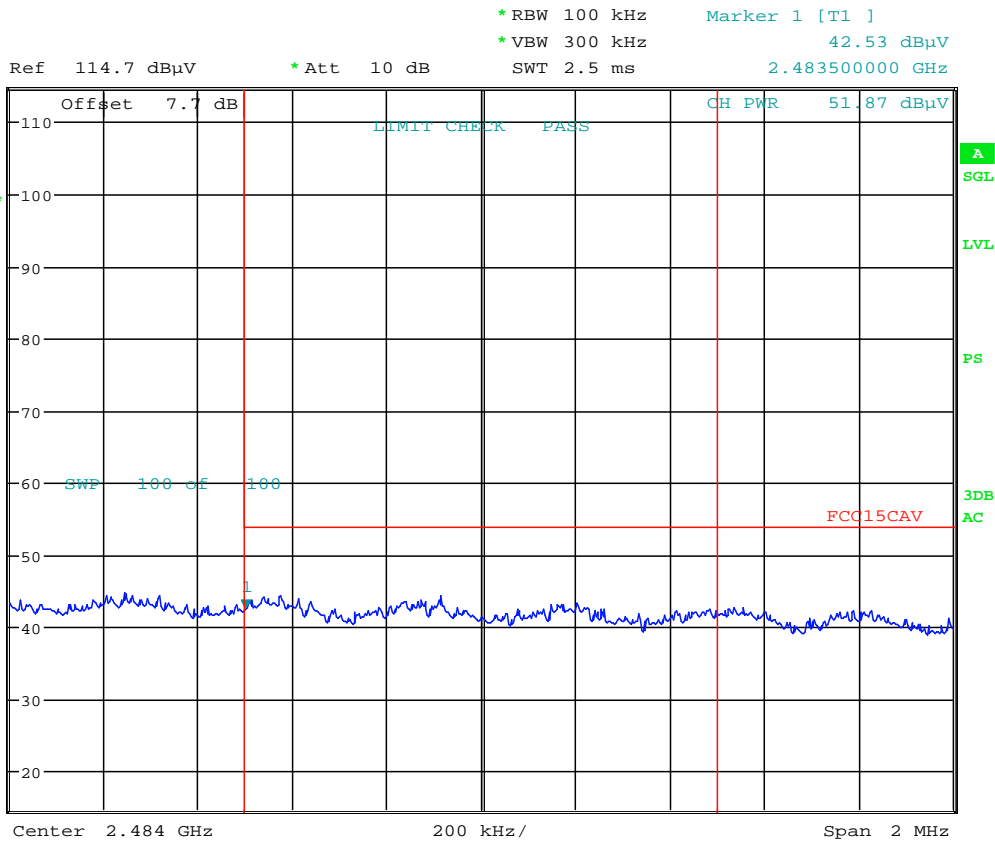

Date: 1.DEC.2016 10:18:48

Plot 7-189. Radiated Restricted Upper Band Edge Measurement (Average)

FCC ID: A3LETWV531		FCC Pt. 15.247 802.11b/g/n/ac MEASUREMENT REPORT (CERTIFICATION)		Approved by: Quality Manager
Test Report S/N: 1M1705180171-02.A3L	Test Dates: 11/23/2016-02/17/2017	EUT Type: Indoor Access Point	Page 139 of 196	

Antenna-1 Radiated Restricted Band Edge Measurements

§15.205 §15.209

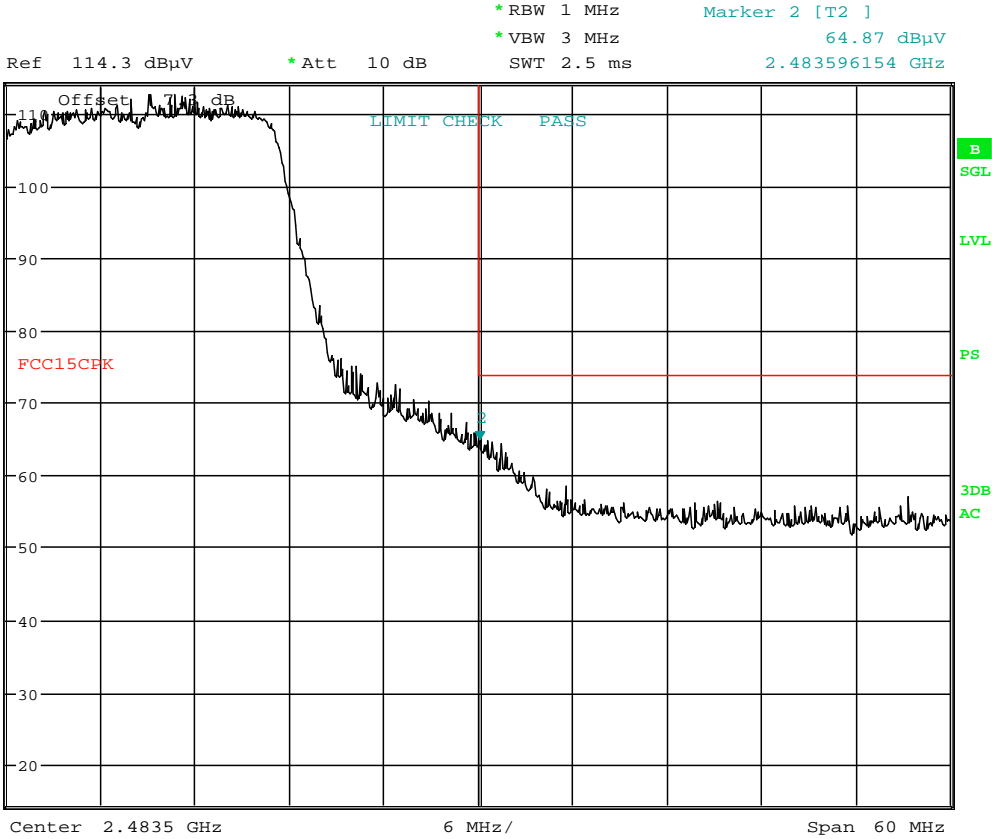

Date: 1.DEC.2016 10:19:09

Plot 7-190. Radiated Restricted Upper Band Edge Measurement (Peak)

FCC ID: A3LETWV531		FCC Pt. 15.247 802.11b/g/n/ac MEASUREMENT REPORT (CERTIFICATION)		Approved by: Quality Manager
Test Report S/N: 1M1705180171-02.A3L	Test Dates: 11/23/2016-02/17/2017	EUT Type: Indoor Access Point	Page 140 of 196	

Antenna-1 Radiated Restricted Band Edge Measurements

§15.205 §15.209

Worst Case Mode: 802.11n/ac (40MHz BW)
 Worst Case Transfer Rate: MCS8
 Distance of Measurements: 3 Meters
 Operating Frequency: 2457MHz
 Channel: 10

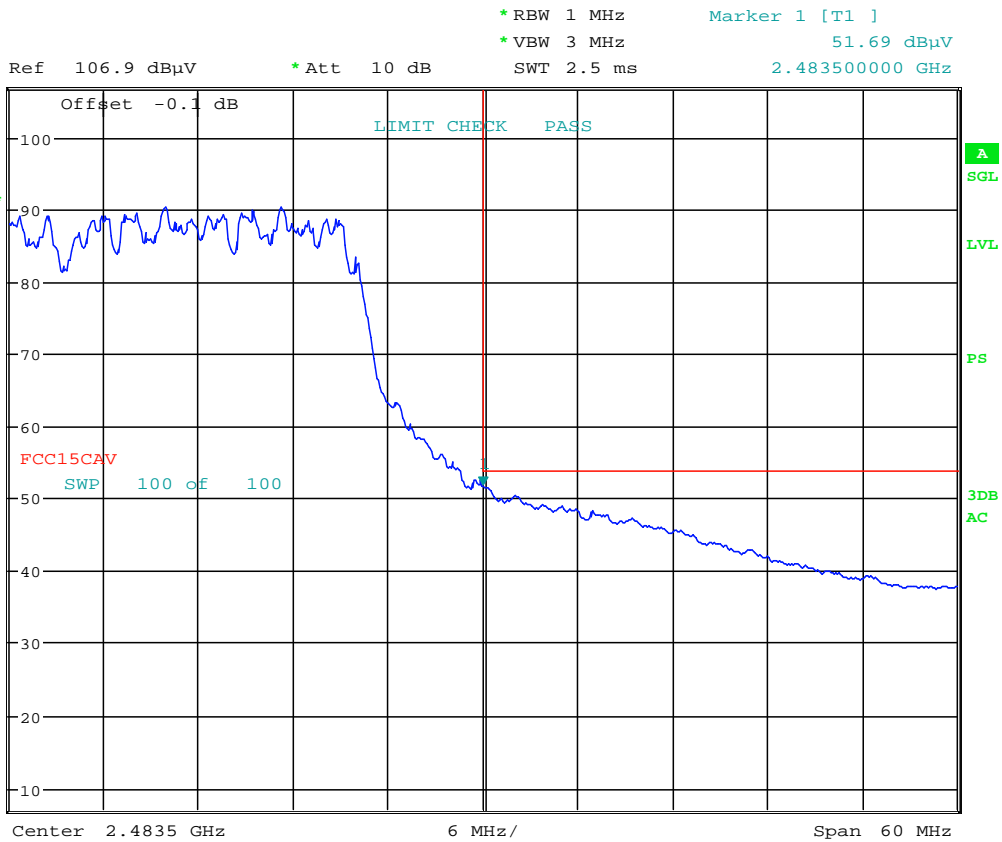

Date: 9.FEB.2017 14:04:55

Plot 7-191. Radiated Restricted Upper Band Edge Measurement (Average)

FCC ID: A3LETWV531		FCC Pt. 15.247 802.11b/g/n/ac MEASUREMENT REPORT (CERTIFICATION)		Approved by: Quality Manager
Test Report S/N: 1M1705180171-02.A3L	Test Dates: 11/23/2016-02/17/2017	EUT Type: Indoor Access Point	Page 141 of 196	

Antenna-1 Radiated Restricted Band Edge Measurements

§15.205 §15.209

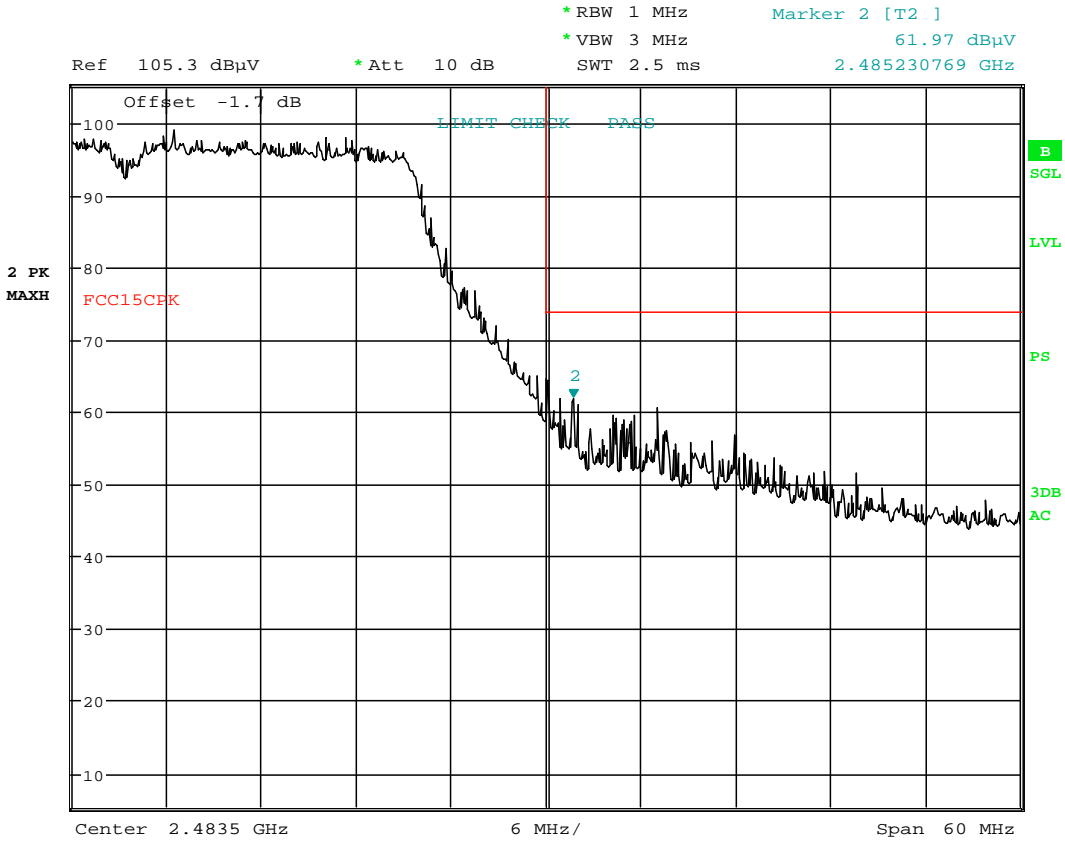

Date: 17.FEB.2017 08:38:16

Plot 7-192. Radiated Restricted Upper Band Edge Measurement (Peak)

FCC ID: A3LETWV531		FCC Pt. 15.247 802.11b/g/n/ac MEASUREMENT REPORT (CERTIFICATION)		Approved by: Quality Manager
Test Report S/N: 1M1705180171-02.A3L	Test Dates: 11/23/2016-02/17/2017	EUT Type: Indoor Access Point	Page 142 of 196	

7.7.6 Antenna-2 Radiated Restricted Band Edge Measurements §15.205 §15.209

The radiated restricted band edge measurements are measured with an EMI test receiver connected to the receive antenna while the EUT is transmitting.

Worst Case Mode: 802.11g
 Worst Case Transfer Rate: 6 Mbps
 Distance of Measurements: 3 Meters
 Operating Frequency: 2412MHz
 Channel: 1

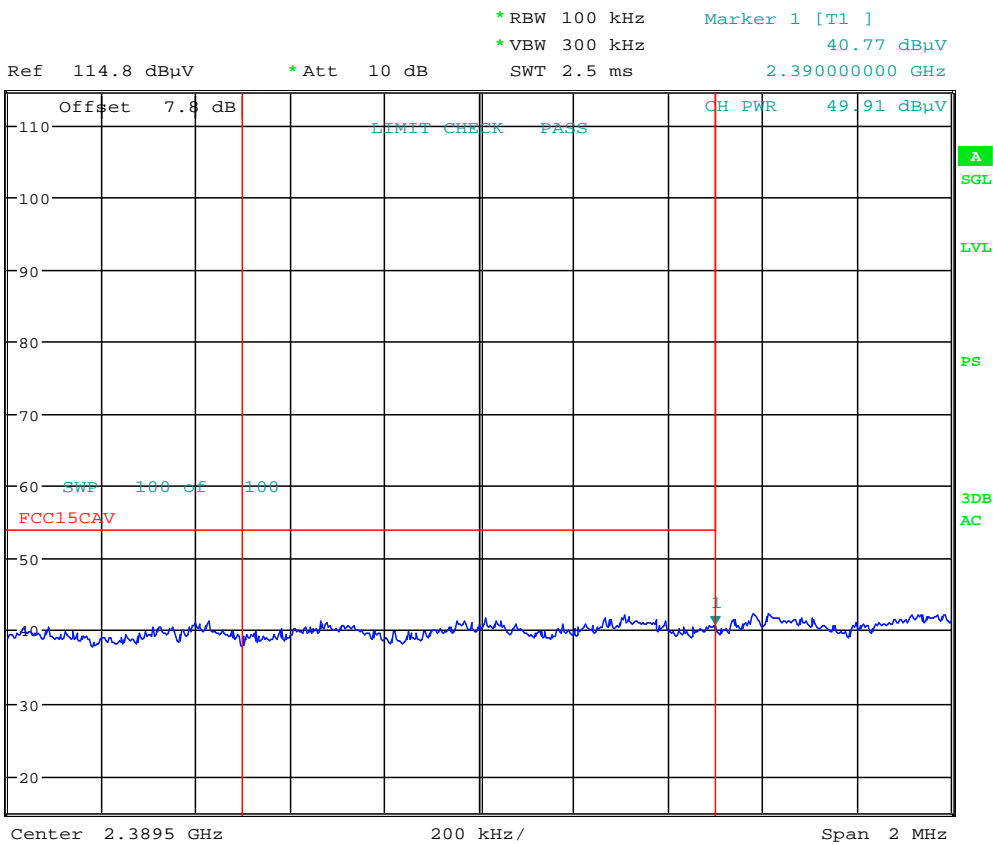

Date: 1.DEC.2016 10:33:32

Plot 7-193. Radiated Restricted Lower Band Edge Measurement (Average)

FCC ID: A3LETWV531		FCC Pt. 15.247 802.11b/g/n/ac MEASUREMENT REPORT (CERTIFICATION)		Approved by: Quality Manager
Test Report S/N: 1M1705180171-02.A3L	Test Dates: 11/23/2016-02/17/2017	EUT Type: Indoor Access Point	Page 143 of 196	

Antenna-2 Radiated Restricted Band Edge Measurements

§15.205 §15.209

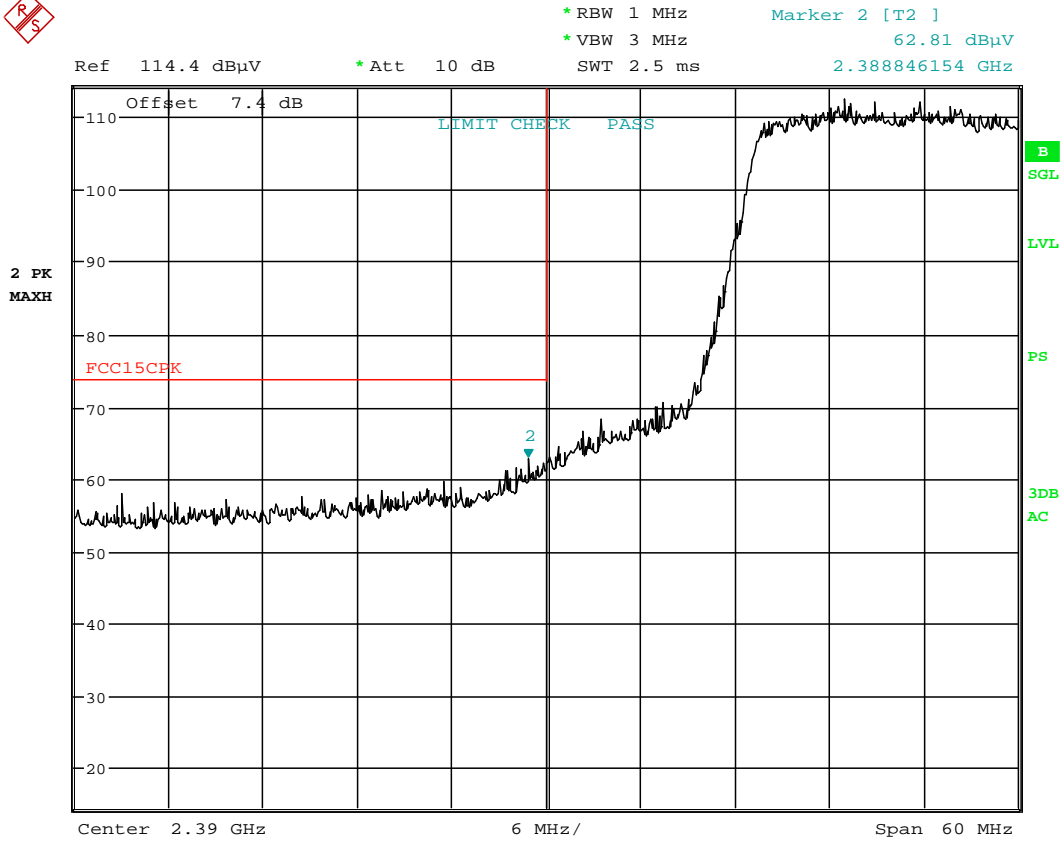

Date: 1.DEC.2016 10:35:03

Plot 7-194. Radiated Restricted Lower Band Edge Measurement (Peak)

FCC ID: A3LETWV531		FCC Pt. 15.247 802.11b/g/n/ac MEASUREMENT REPORT (CERTIFICATION)		Approved by: Quality Manager
Test Report S/N: 1M1705180171-02.A3L	Test Dates: 11/23/2016-02/17/2017	EUT Type: Indoor Access Point		Page 144 of 196

Antenna-2 Radiated Restricted Band Edge Measurements

§15.205 §15.209

The radiated restricted band edge measurements are measured with an EMI test receiver connected to the receive antenna while the EUT is transmitting.

Worst Case Mode: 802.11n/ac (40MHz BW)
 Worst Case Transfer Rate: MCS8
 Distance of Measurements: 3 Meters
 Operating Frequency: 2422MHz
 Channel: 3

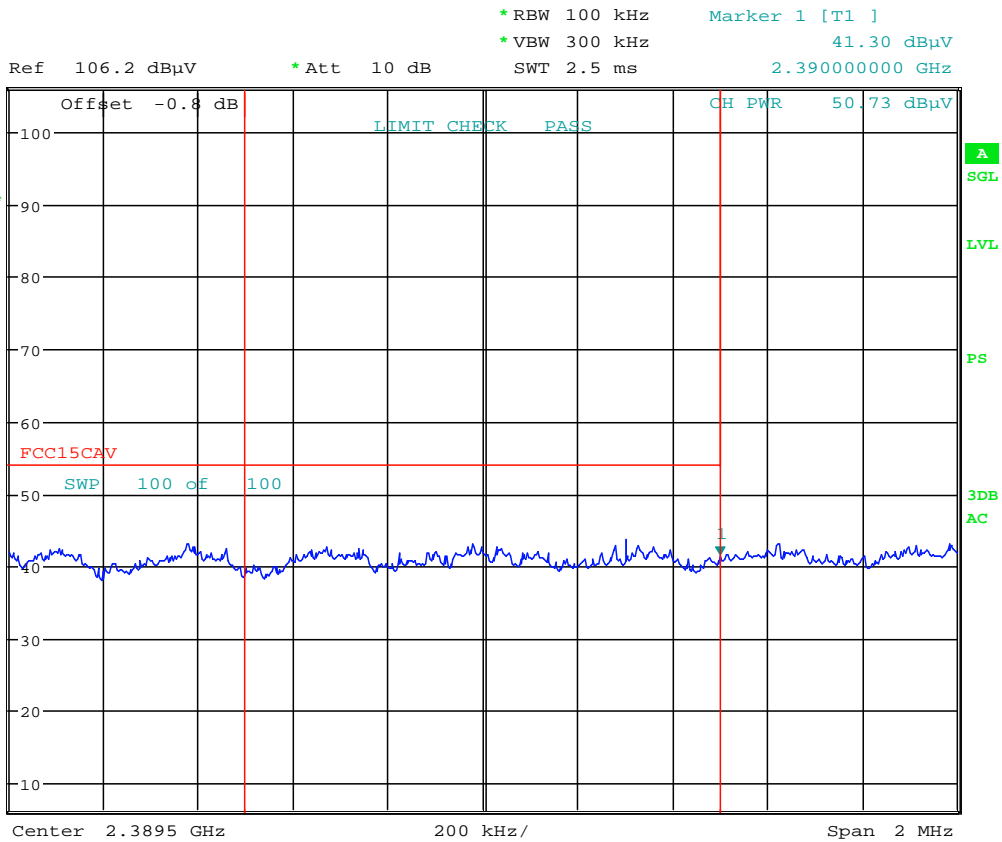

Date: 13.FEB.2017 14:29:10

Plot 7-195. Radiated Restricted Lower Band Edge Measurement (Average)

FCC ID: A3LETWV531		FCC Pt. 15.247 802.11b/g/n/ac MEASUREMENT REPORT (CERTIFICATION)		Approved by: Quality Manager
Test Report S/N: 1M1705180171-02.A3L	Test Dates: 11/23/2016-02/17/2017	EUT Type: Indoor Access Point		Page 145 of 196

Antenna-2 Radiated Restricted Band Edge Measurements

§15.205 §15.209

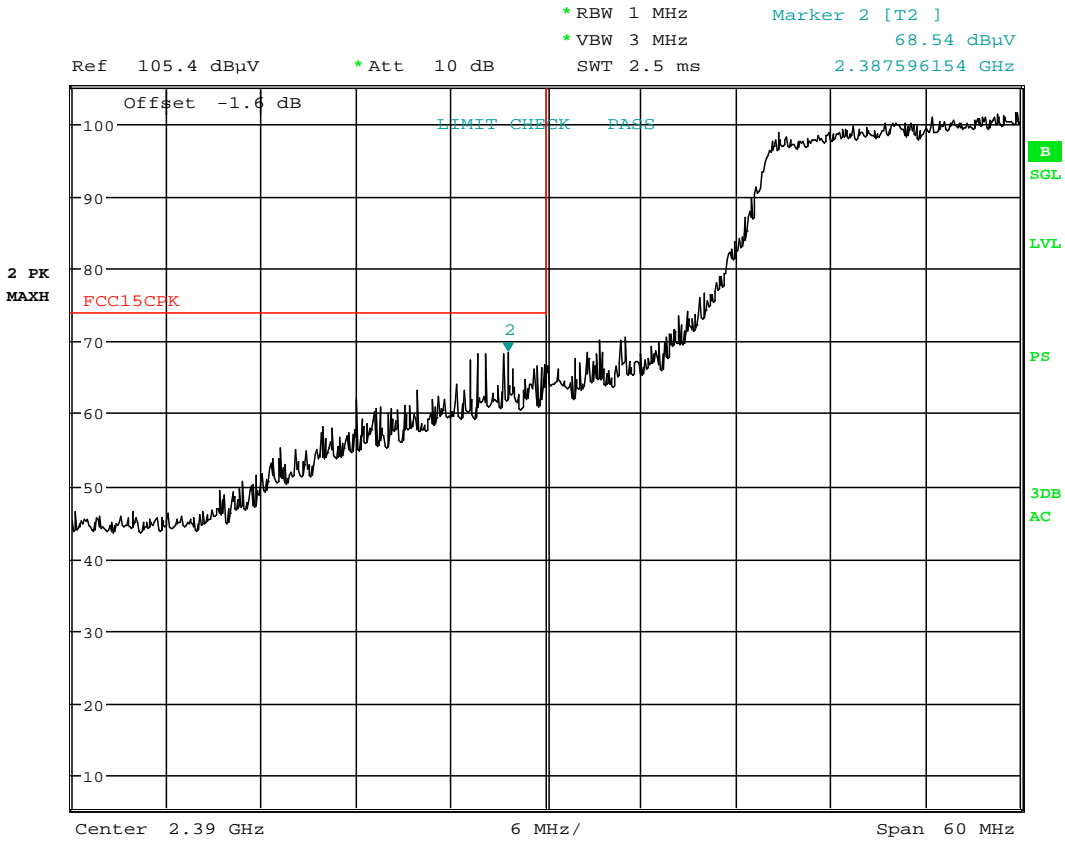

Date: 17.FEB.2017 08:46:22

Plot 7-196. Radiated Restricted Lower Band Edge Measurement (Peak)

FCC ID: A3LETWV531		FCC Pt. 15.247 802.11b/g/n/ac MEASUREMENT REPORT (CERTIFICATION)		Approved by: Quality Manager
Test Report S/N: 1M1705180171-02.A3L	Test Dates: 11/23/2016-02/17/2017	EUT Type: Indoor Access Point	Page 146 of 196	

Antenna-2 Radiated Restricted Band Edge Measurements

§15.205 §15.209

Worst Case Mode: 802.11g

Worst Case Transfer Rate: 6 Mbps

Distance of Measurements: 3 Meters

Operating Frequency: 2462MHz

Channel: 11

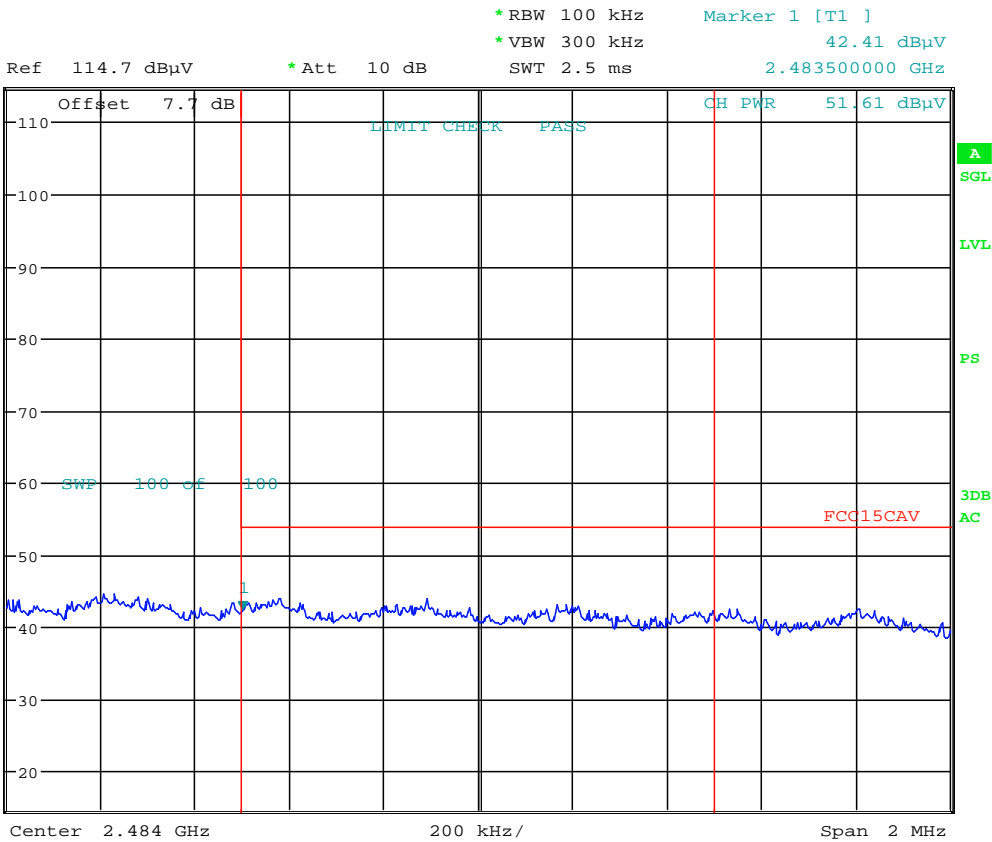

Date: 1.DEC.2016 10:25:48

Plot 7-197. Radiated Restricted Upper Band Edge Measurement (Average)

FCC ID: A3LETWV531		FCC Pt. 15.247 802.11b/g/n/ac MEASUREMENT REPORT (CERTIFICATION)		Approved by: Quality Manager
Test Report S/N: 1M1705180171-02.A3L	Test Dates: 11/23/2016-02/17/2017	EUT Type: Indoor Access Point	Page 147 of 196	

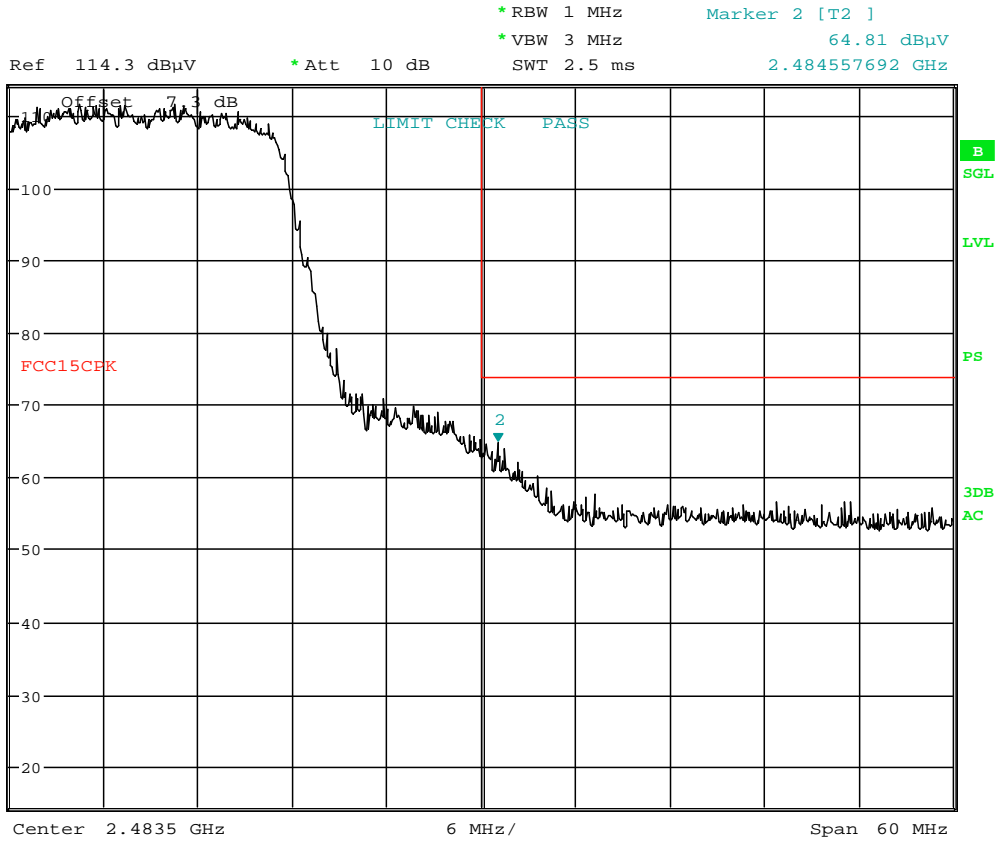

Antenna-2 Radiated Restricted Band Edge Measurements

§15.205 §15.209



Date: 1.DEC.2016 10:26:20

Plot 7-198. Radiated Restricted Upper Band Edge Measurement (Peak)

FCC ID: A3LETWV531		FCC Pt. 15.247 802.11b/g/n/ac MEASUREMENT REPORT (CERTIFICATION)		Approved by: Quality Manager
Test Report S/N: 1M1705180171-02.A3L	Test Dates: 11/23/2016-02/17/2017	EUT Type: Indoor Access Point	Page 148 of 196	

Antenna-2 Radiated Restricted Band Edge Measurements

§15.205 §15.209

Worst Case Mode: 802.11n/ac (40MHz BW)
 Worst Case Transfer Rate: MCS8
 Distance of Measurements: 3 Meters
 Operating Frequency: 2457MHz
 Channel: 10

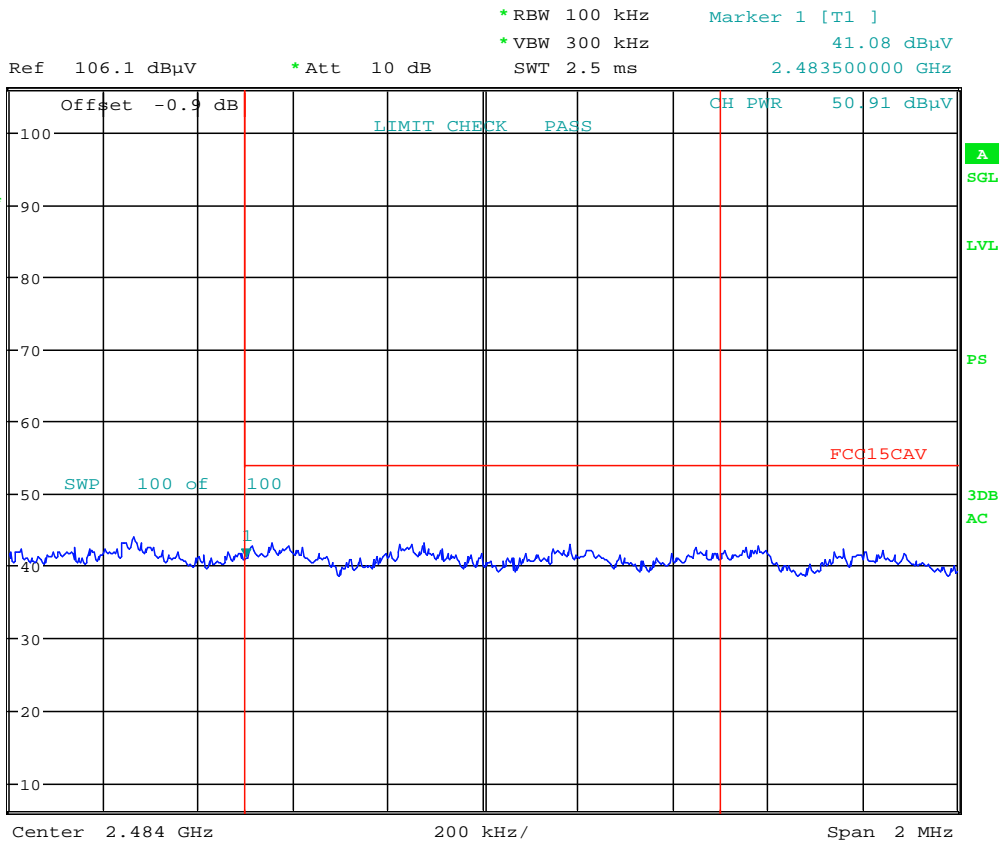

Date: 13.FEB.2017 13:09:56

Plot 7-199. Radiated Restricted Upper Band Edge Measurement (Average)

FCC ID: A3LETWV531		FCC Pt. 15.247 802.11b/g/n/ac MEASUREMENT REPORT (CERTIFICATION)		Approved by: Quality Manager
Test Report S/N: 1M1705180171-02.A3L	Test Dates: 11/23/2016-02/17/2017	EUT Type: Indoor Access Point	Page 149 of 196	

Antenna-2 Radiated Restricted Band Edge Measurements

§15.205 §15.209

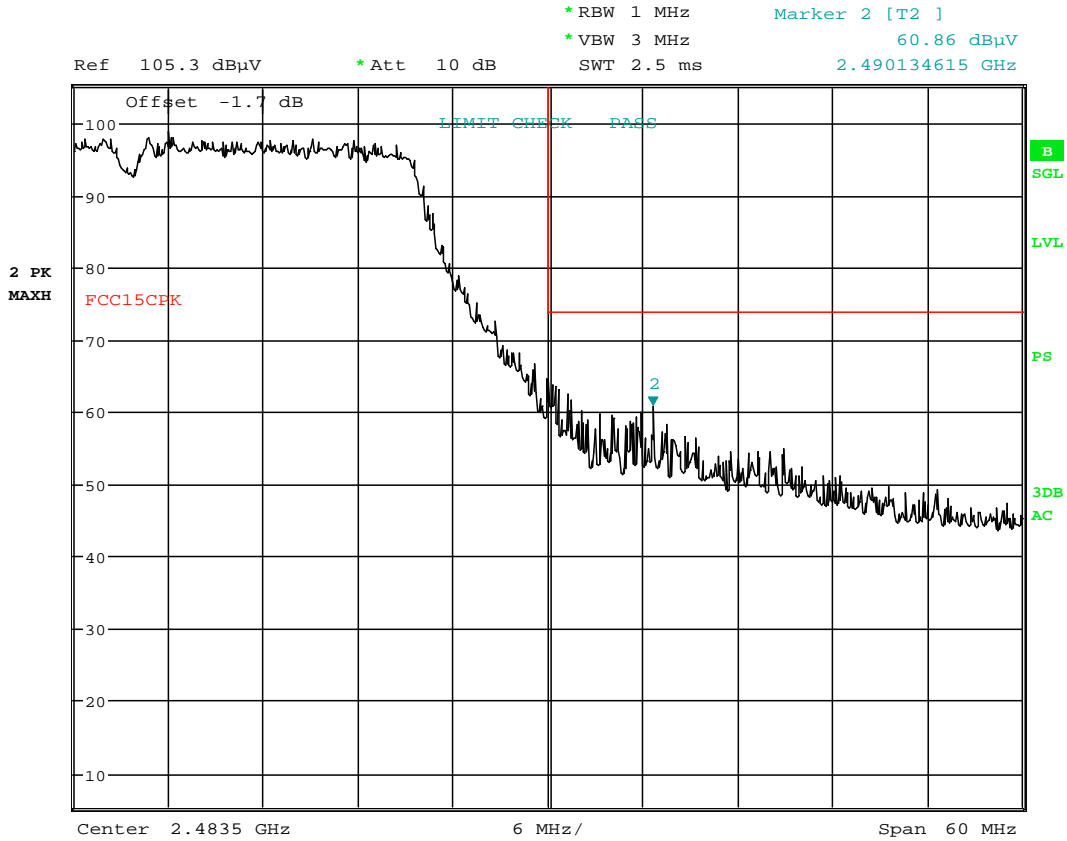

Date: 17.FEB.2017 08:40:15

Plot 7-200. Radiated Restricted Upper Band Edge Measurement (Peak)

FCC ID: A3LETWV531		FCC Pt. 15.247 802.11b/g/n/ac MEASUREMENT REPORT (CERTIFICATION)		Approved by: Quality Manager
Test Report S/N: 1M1705180171-02.A3L	Test Dates: 11/23/2016-02/17/2017	EUT Type: Indoor Access Point	Page 150 of 196	

7.8 Antenna-3 Radiated Restricted Band Edge Measurements

\$15.205 \$15.209

The radiated restricted band edge measurements are measured with an EMI test receiver connected to the receive antenna while the EUT is transmitting.

Worst Case Mode: 802.11g

Worst Case Transfer Rate: 6 Mbps

Distance of Measurements: 3 Meters

Operating Frequency: 2412MHz

Channel: 1

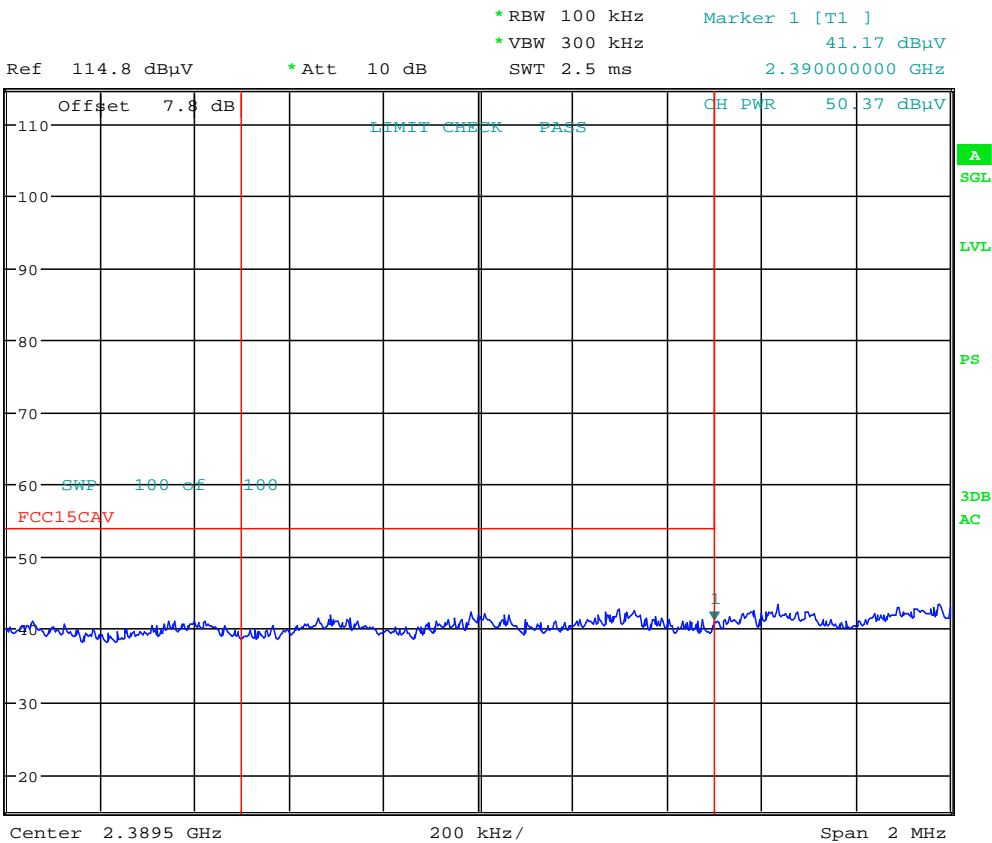

Date: 1.DEC.2016 10:43:06

Plot 7-201. Radiated Restricted Lower Band Edge Measurement (Average)

FCC ID: A3LETWV531		FCC Pt. 15.247 802.11b/g/n/ac MEASUREMENT REPORT (CERTIFICATION)		Approved by: Quality Manager
Test Report S/N: 1M1705180171-02.A3L	Test Dates: 11/23/2016-02/17/2017	EUT Type: Indoor Access Point		Page 151 of 196

Antenna-3 Radiated Restricted Band Edge Measurements

§15.205 §15.209

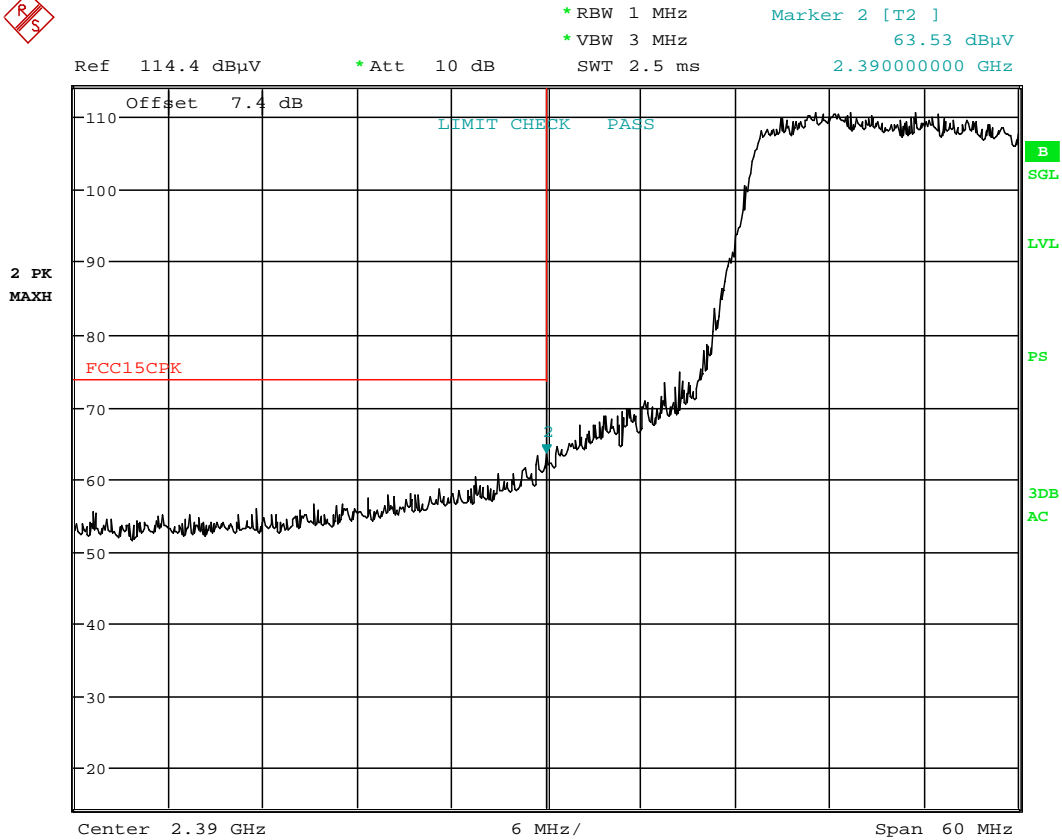

Date: 1.DEC.2016 10:44:15

Plot 7-202. Radiated Restricted Lower Band Edge Measurement (Peak)

FCC ID: A3LETWV531		FCC Pt. 15.247 802.11b/g/n/ac MEASUREMENT REPORT (CERTIFICATION)		Approved by: Quality Manager
Test Report S/N: 1M1705180171-02.A3L	Test Dates: 11/23/2016-02/17/2017	EUT Type: Indoor Access Point		Page 152 of 196

Antenna-3 Radiated Restricted Band Edge Measurements §15.205 §15.209

The radiated restricted band edge measurements are measured with an EMI test receiver connected to the receive antenna while the EUT is transmitting.

Worst Case Mode: 802.11n/ac (40MHz BW)
 Worst Case Transfer Rate: MCS8
 Distance of Measurements: 3 Meters
 Operating Frequency: 2422MHz
 Channel: 3

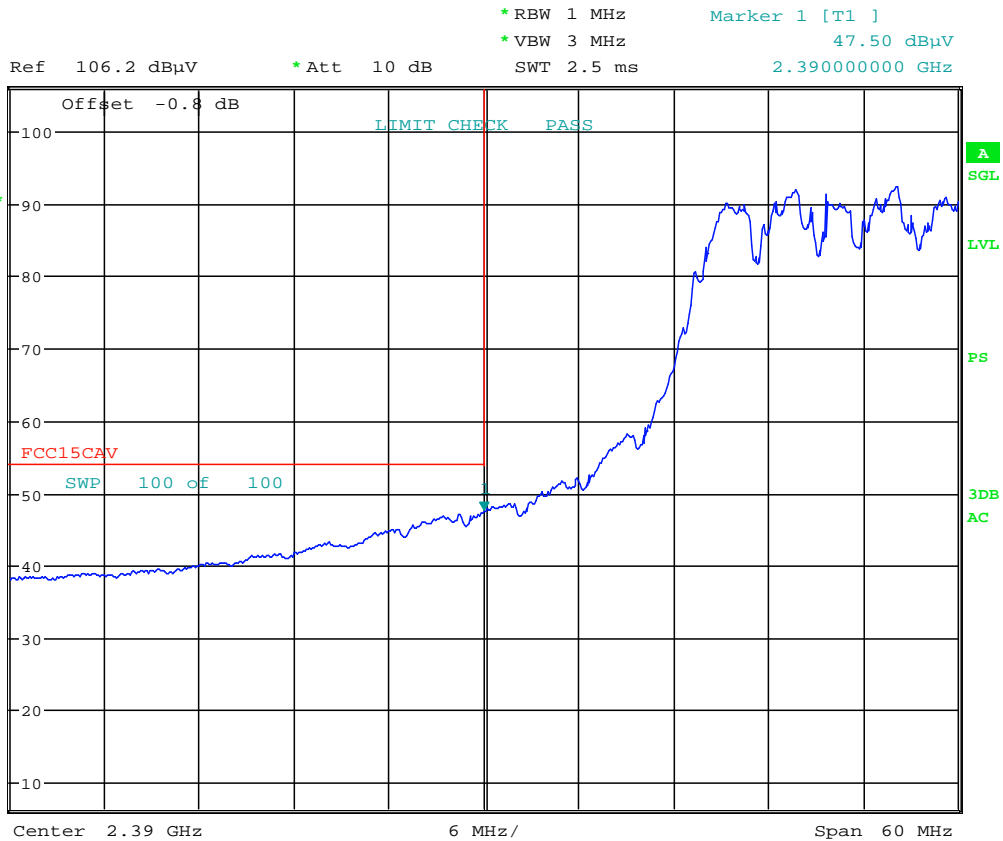

Date: 13.FEB.2017 16:38:04

Plot 7-203. Radiated Restricted Lower Band Edge Measurement (Average)

FCC ID: A3LETWV531		FCC Pt. 15.247 802.11b/g/n/ac MEASUREMENT REPORT (CERTIFICATION)		Approved by: Quality Manager
Test Report S/N: 1M1705180171-02.A3L	Test Dates: 11/23/2016-02/17/2017	EUT Type: Indoor Access Point		Page 153 of 196

Antenna-3 Radiated Restricted Band Edge Measurements

§15.205 §15.209

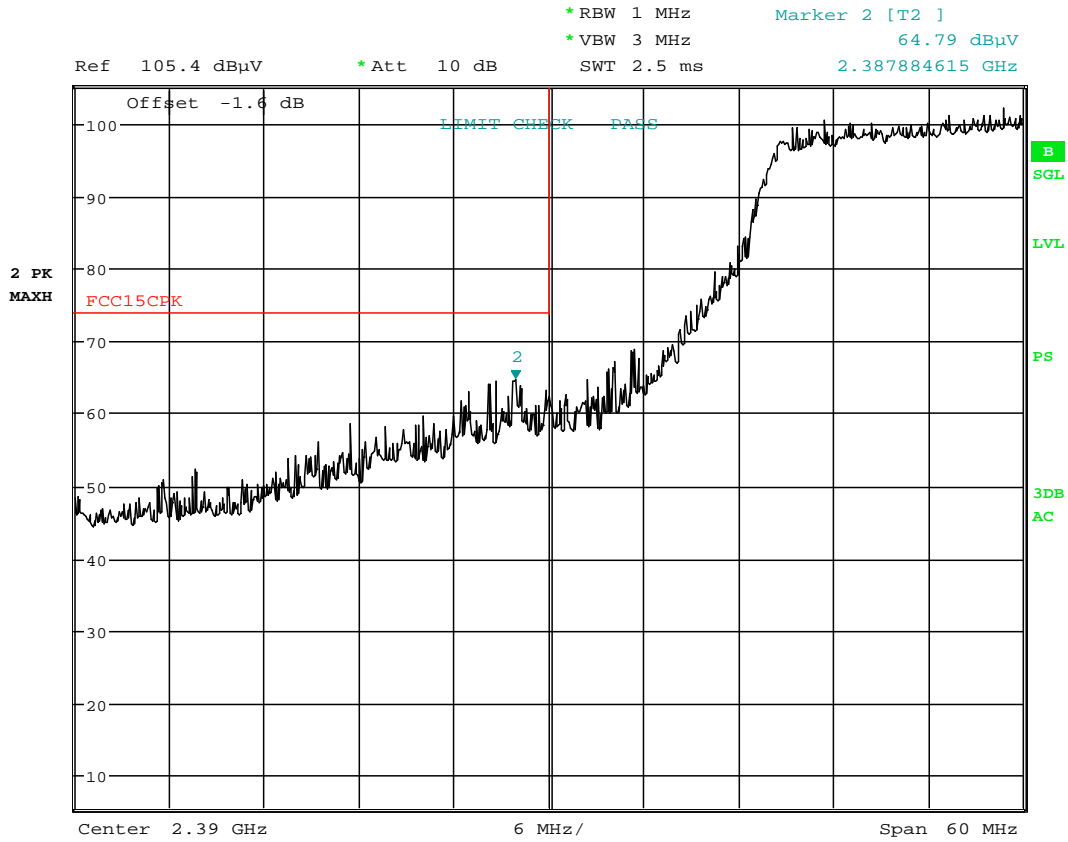

Date: 17.FEB.2017 08:49:41

Plot 7-204. Radiated Restricted Upper Band Edge Measurement (Average)

FCC ID: A3LETWV531		FCC Pt. 15.247 802.11b/g/n/ac MEASUREMENT REPORT (CERTIFICATION)		Approved by: Quality Manager
Test Report S/N: 1M1705180171-02.A3L	Test Dates: 11/23/2016-02/17/2017	EUT Type: Indoor Access Point	Page 154 of 196	

Antenna-3 Radiated Restricted Band Edge Measurements

§15.205 §15.209

Worst Case Mode: 802.11g

Worst Case Transfer Rate: 6 Mbps

Distance of Measurements: 3 Meters

Operating Frequency: 2462MHz

Channel: 11

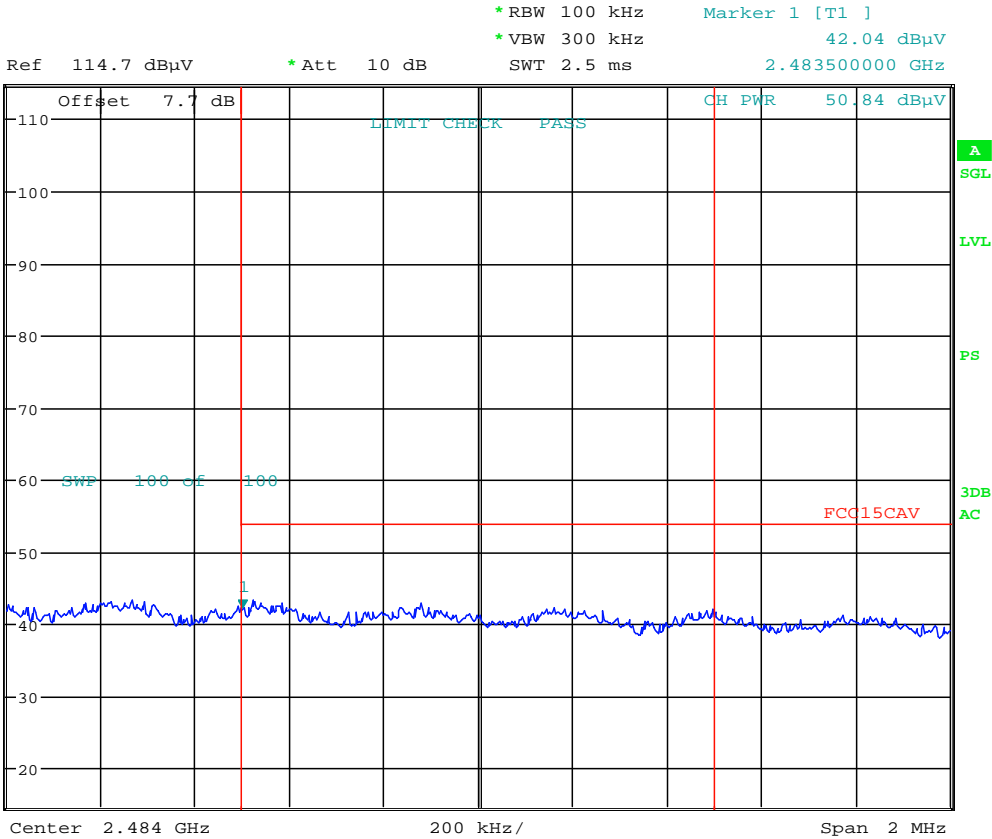

Date: 1.DEC.2016 10:49:39

Plot 7-205. Radiated Restricted Upper Band Edge Measurement (Average)

FCC ID: A3LETWV531		FCC Pt. 15.247 802.11b/g/n/ac MEASUREMENT REPORT (CERTIFICATION)		Approved by: Quality Manager
Test Report S/N: 1M1705180171-02.A3L	Test Dates: 11/23/2016-02/17/2017	EUT Type: Indoor Access Point	Page 155 of 196	

Antenna-3 Radiated Restricted Band Edge Measurements

§15.205 §15.209

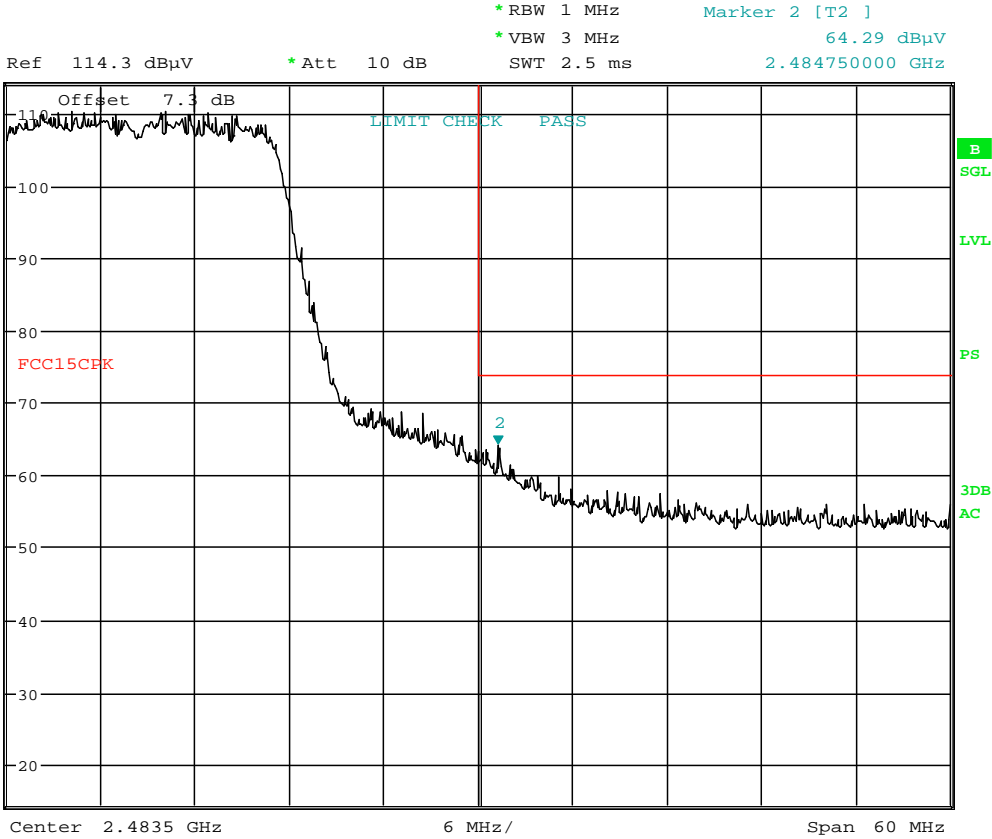

Date: 1.DEC.2016 10:50:19

Plot 7-206. Radiated Restricted Upper Band Edge Measurement (Peak)

FCC ID: A3LETWV531		FCC Pt. 15.247 802.11b/g/n/ac MEASUREMENT REPORT (CERTIFICATION)		Approved by: Quality Manager
Test Report S/N: 1M1705180171-02.A3L	Test Dates: 11/23/2016-02/17/2017	EUT Type: Indoor Access Point	Page 156 of 196	

Antenna-3 Radiated Restricted Band Edge Measurements

§15.205 §15.209

Worst Case Mode: 802.11n/ac (40MHz BW)
 Worst Case Transfer Rate: MCS8
 Distance of Measurements: 3 Meters
 Operating Frequency: 2457MHz
 Channel: 10

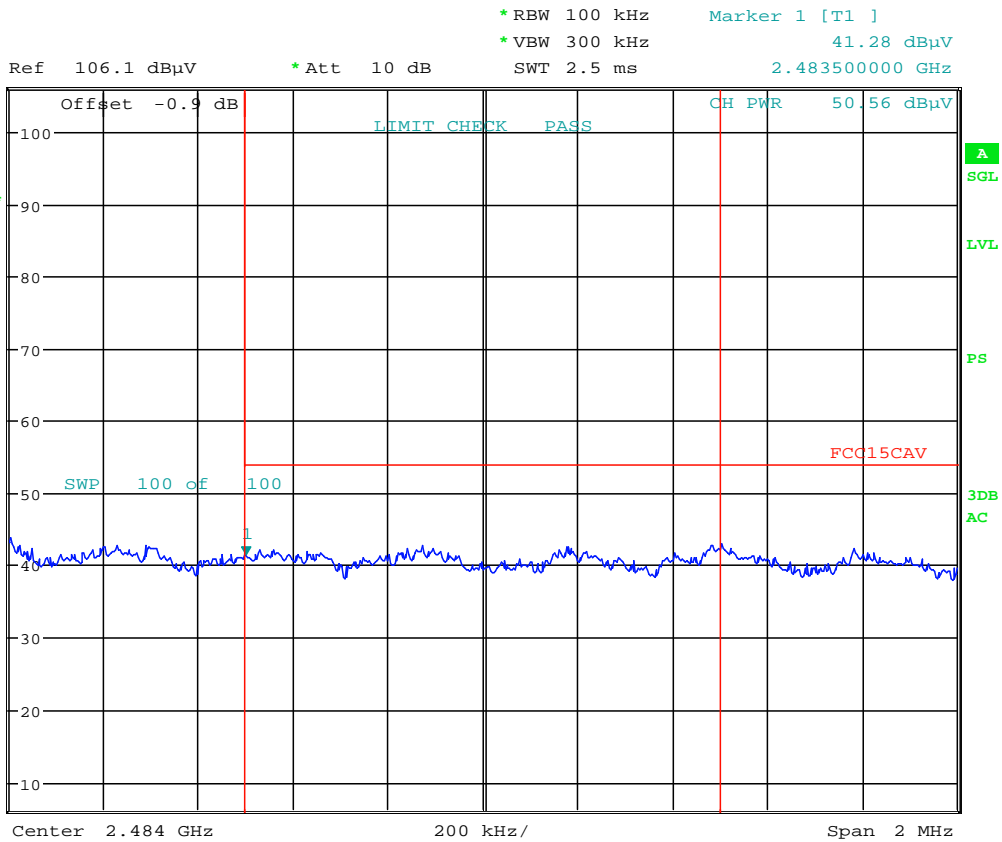

Date: 13.FEB.2017 15:18:48

Plot 7-207. Radiated Restricted Upper Band Edge Measurement (Average)

FCC ID: A3LETWV531		FCC Pt. 15.247 802.11b/g/n/ac MEASUREMENT REPORT (CERTIFICATION)		Approved by: Quality Manager
Test Report S/N: 1M1705180171-02.A3L	Test Dates: 11/23/2016-02/17/2017	EUT Type: Indoor Access Point	Page 157 of 196	

Antenna-3 Radiated Restricted Band Edge Measurements

§15.205 §15.209

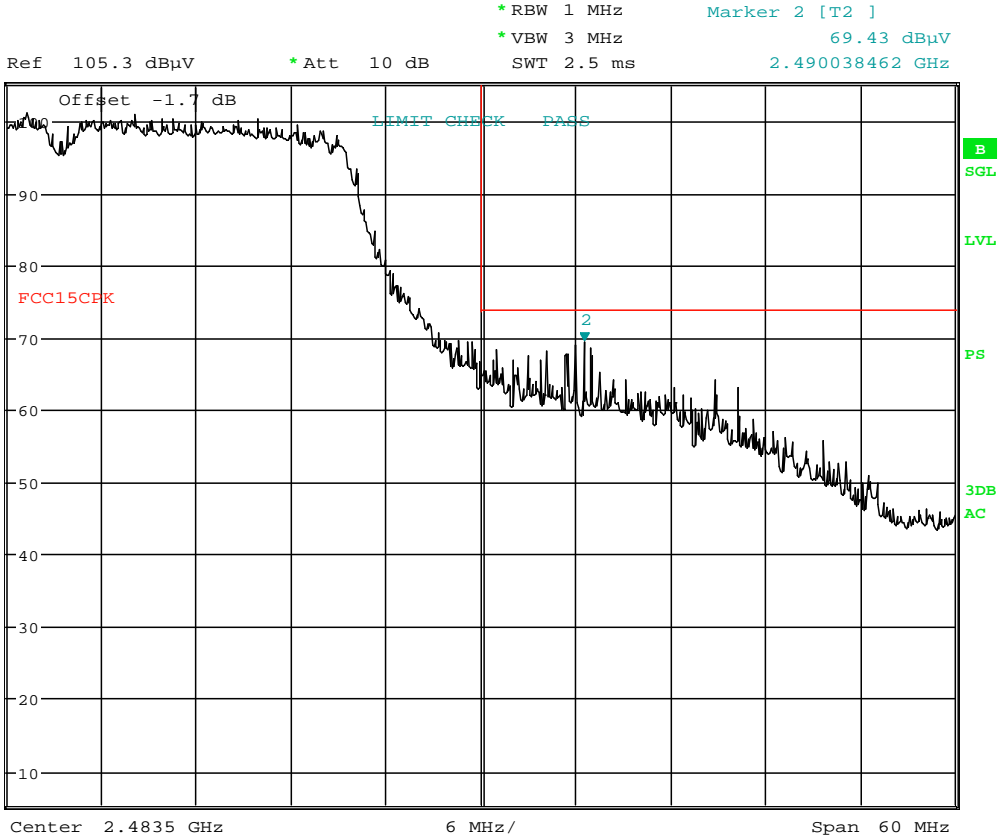

Date: 13.FEB.2017 15:19:22

Plot 7-208. Radiated Restricted Upper Band Edge Measurement (Peak)

FCC ID: A3LETWV531		FCC Pt. 15.247 802.11b/g/n/ac MEASUREMENT REPORT (CERTIFICATION)		Approved by: Quality Manager
Test Report S/N: 1M1705180171-02.A3L	Test Dates: 11/23/2016-02/17/2017	EUT Type: Indoor Access Point		Page 158 of 196

7.8.1 Antenna-4 Radiated Restricted Band Edge Measurements

§15.205 §15.209

The radiated restricted band edge measurements are measured with an EMI test receiver connected to the receive antenna while the EUT is transmitting.

Worst Case Mode: 802.11g

Worst Case Transfer Rate: 6 Mbps

Distance of Measurements: 3 Meters

Operating Frequency: 2412MHz

Channel: 1

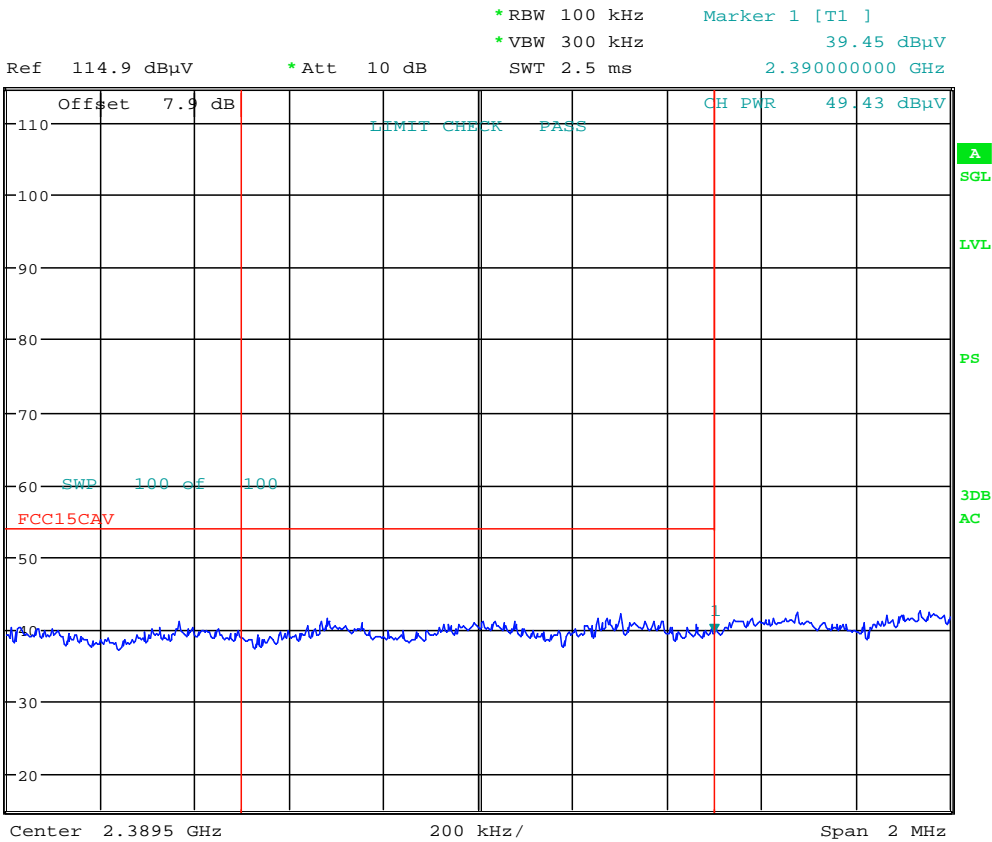

Date: 1.DEC.2016 11:16:49

Plot 7-209. Radiated Restricted Lower Band Edge Measurement (Average)

FCC ID: A3LETWV531		FCC Pt. 15.247 802.11b/g/n/ac MEASUREMENT REPORT (CERTIFICATION)		Approved by: Quality Manager
Test Report S/N: 1M1705180171-02.A3L	Test Dates: 11/23/2016-02/17/2017	EUT Type: Indoor Access Point	Page 159 of 196	

Antenna-4 Radiated Restricted Band Edge Measurements

§15.205 §15.209

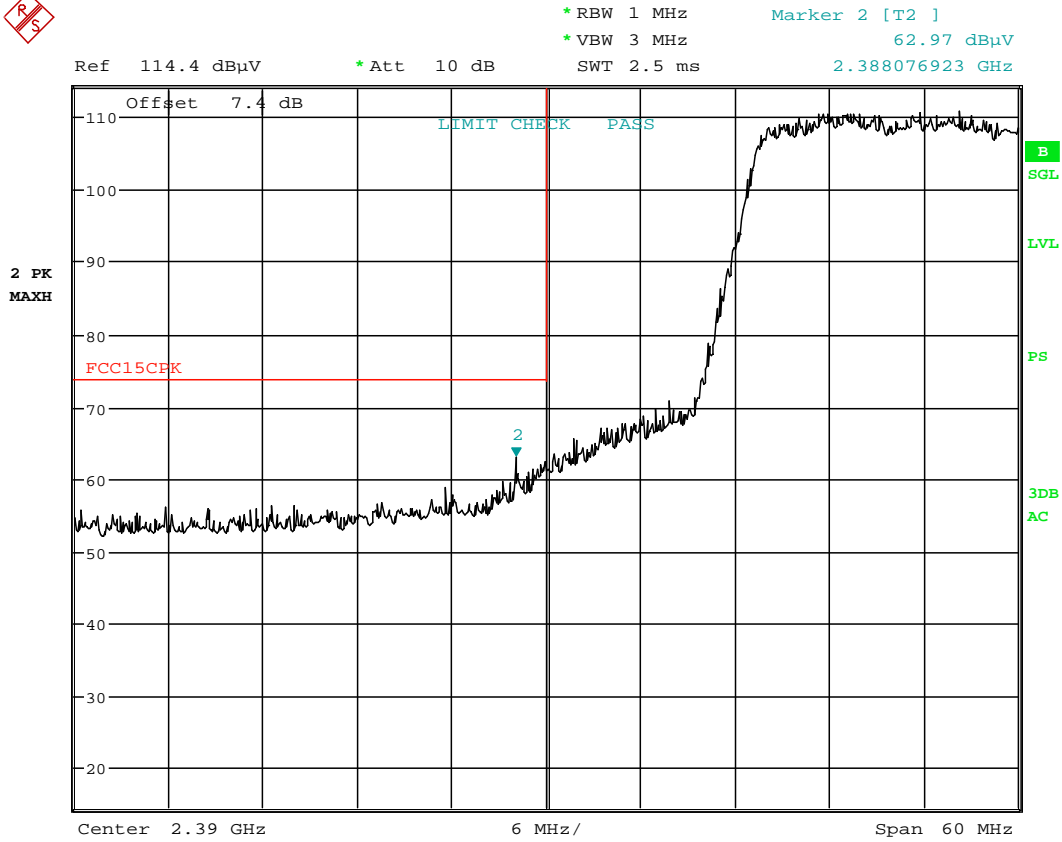

Date: 1.DEC.2016 11:17:09

Plot 7-210. Radiated Restricted Lower Band Edge Measurement (Peak)

FCC ID: A3LETWV531		FCC Pt. 15.247 802.11b/g/n/ac MEASUREMENT REPORT (CERTIFICATION)		Approved by: Quality Manager
Test Report S/N: 1M1705180171-02.A3L	Test Dates: 11/23/2016-02/17/2017	EUT Type: Indoor Access Point	Page 160 of 196	

Antenna-4 Radiated Restricted Band Edge Measurements §15.205 §15.209

The radiated restricted band edge measurements are measured with an EMI test receiver connected to the receive antenna while the EUT is transmitting.

Worst Case Mode: 802.11n/ac (40MHz BW)
 Worst Case Transfer Rate: MCS8
 Distance of Measurements: 3 Meters
 Operating Frequency: 2422MHz
 Channel: 3

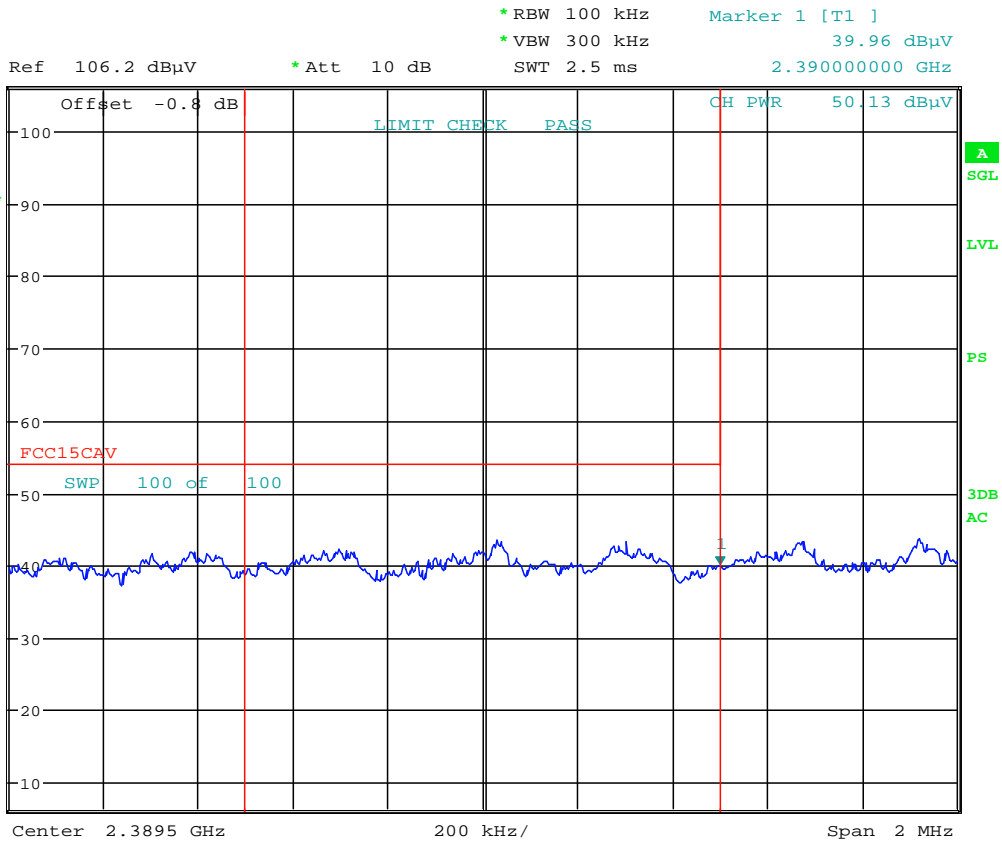

Date: 13.FEB.2017 17:39:47

Plot 7-211. Radiated Restricted Lower Band Edge Measurement (Average)

FCC ID: A3LETWV531		FCC Pt. 15.247 802.11b/g/n/ac MEASUREMENT REPORT (CERTIFICATION)		Approved by: Quality Manager
Test Report S/N: 1M1705180171-02.A3L	Test Dates: 11/23/2016-02/17/2017	EUT Type: Indoor Access Point	Page 161 of 196	

Antenna-4 Radiated Restricted Band Edge Measurements

§15.205 §15.209

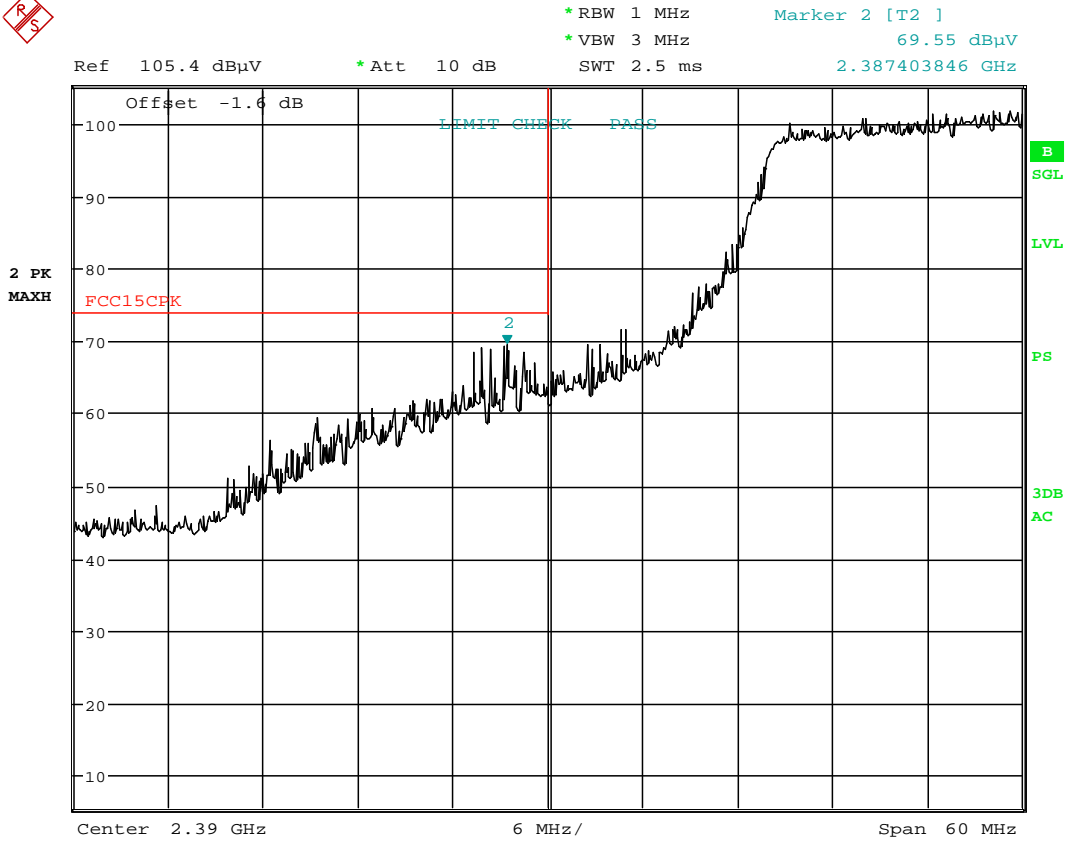

Date: 13.FEB.2017 17:40:29

Plot 7-212. Radiated Restricted Upper Band Edge Measurement (Average)

FCC ID: A3LETWV531		FCC Pt. 15.247 802.11b/g/n/ac MEASUREMENT REPORT (CERTIFICATION)		Approved by: Quality Manager
Test Report S/N: 1M1705180171-02.A3L	Test Dates: 11/23/2016-02/17/2017	EUT Type: Indoor Access Point	Page 162 of 196	

Antenna-4 Radiated Restricted Band Edge Measurements

§15.205 §15.209

Worst Case Mode: 802.11g

Worst Case Transfer Rate: 6 Mbps

Distance of Measurements: 3 Meters

Operating Frequency: 2462MHz

Channel: 11

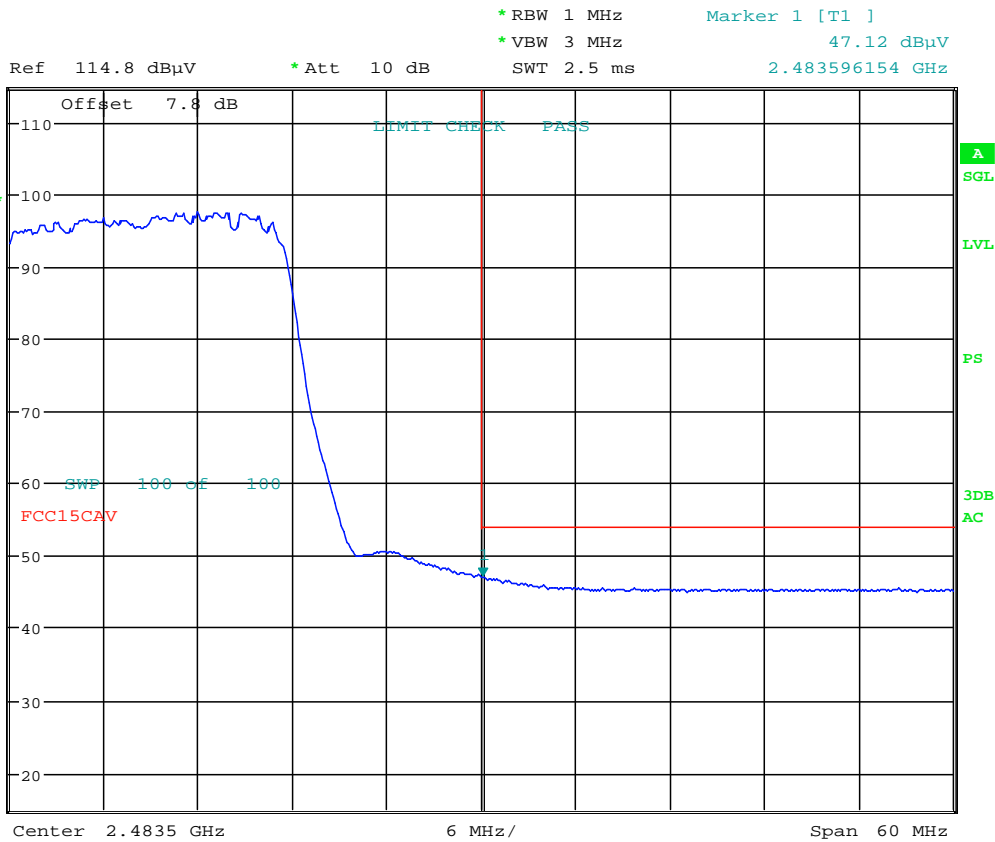

Date: 1.DEC.2016 11:10:56

Plot 7-213. Radiated Restricted Upper Band Edge Measurement (Average)

FCC ID: A3LETWV531		FCC Pt. 15.247 802.11b/g/n/ac MEASUREMENT REPORT (CERTIFICATION)		Approved by: Quality Manager
Test Report S/N: 1M1705180171-02.A3L	Test Dates: 11/23/2016-02/17/2017	EUT Type: Indoor Access Point	Page 163 of 196	

Antenna-4 Radiated Restricted Band Edge Measurements

§15.205 §15.209

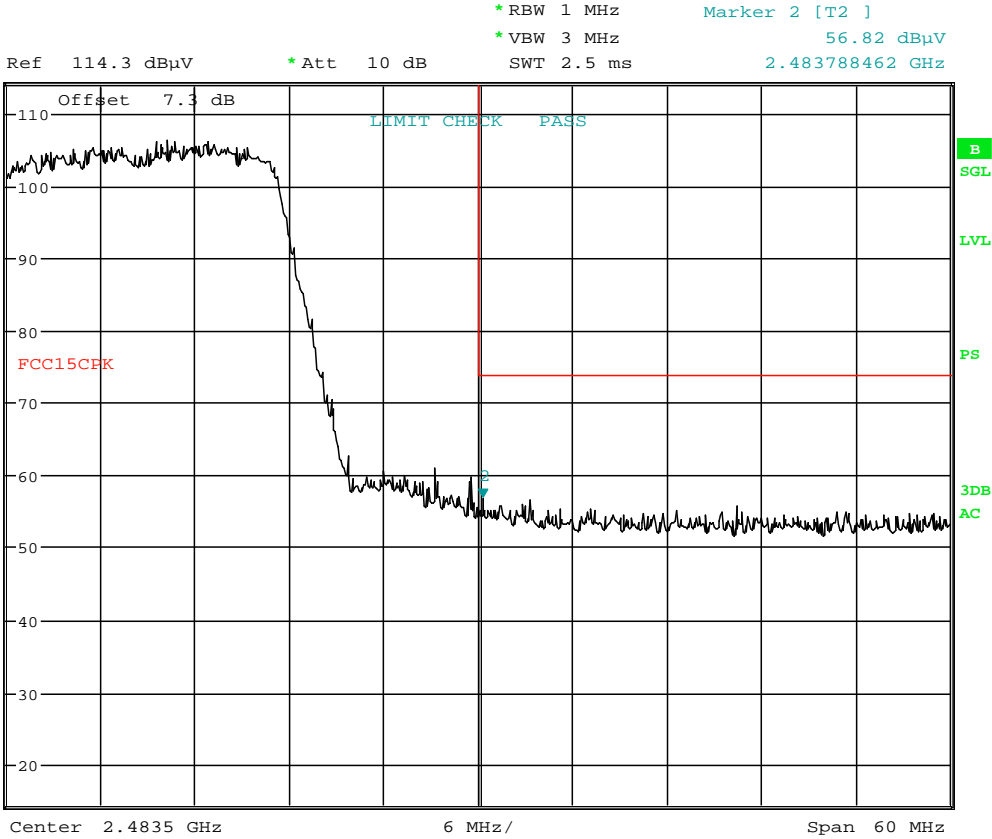

Date: 1.DEC.2016 11:11:13

Plot 7-214. Radiated Restricted Upper Band Edge Measurement (Peak)

FCC ID: A3LETWV531		FCC Pt. 15.247 802.11b/g/n/ac MEASUREMENT REPORT (CERTIFICATION)		Approved by: Quality Manager
Test Report S/N: 1M1705180171-02.A3L	Test Dates: 11/23/2016-02/17/2017	EUT Type: Indoor Access Point		Page 164 of 196

Antenna-4 Radiated Restricted Band Edge Measurements

§15.205 §15.209

Worst Case Mode: 802.11n/ac (40MHz BW)

Worst Case Transfer Rate: MCS8

Distance of Measurements: 3 Meters

Operating Frequency: 2457MHz

Channel: 10

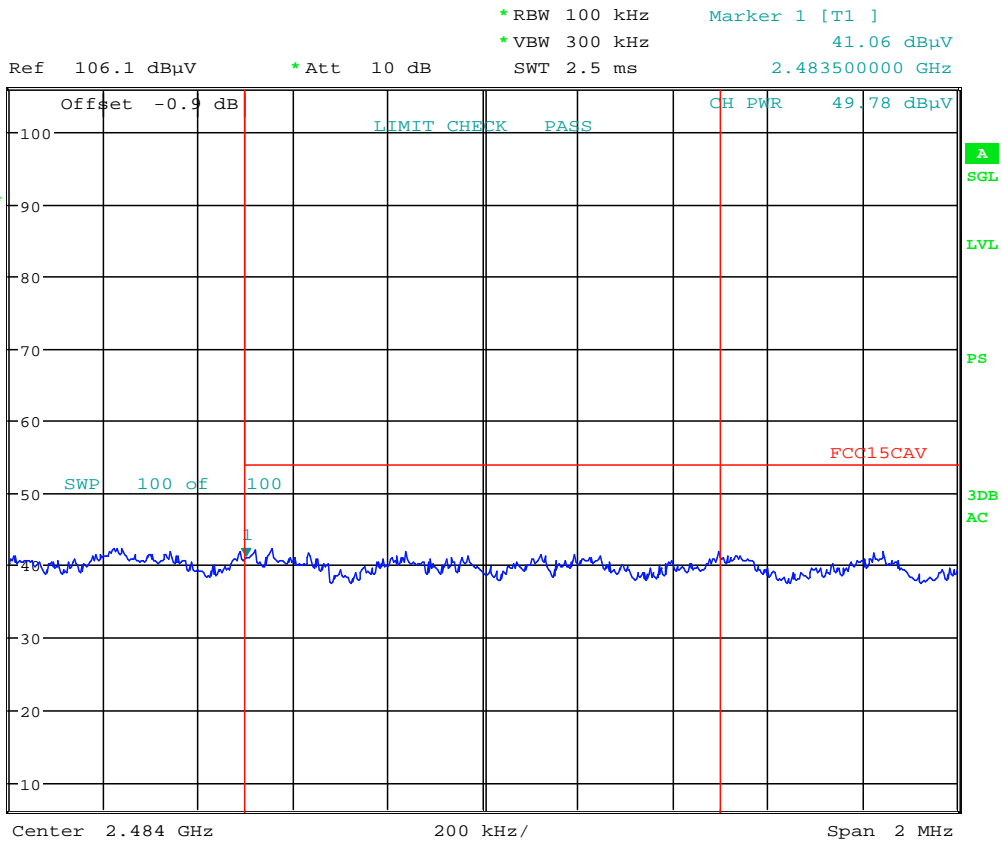

Date: 13.FEB.2017 16:52:52

Plot 7-215. Radiated Restricted Upper Band Edge Measurement (Average)

FCC ID: A3LETWV531		FCC Pt. 15.247 802.11b/g/n/ac MEASUREMENT REPORT (CERTIFICATION)		Approved by: Quality Manager
Test Report S/N: 1M1705180171-02.A3L	Test Dates: 11/23/2016-02/17/2017	EUT Type: Indoor Access Point		Page 165 of 196

Antenna-4 Radiated Restricted Band Edge Measurements

§15.205 §15.209

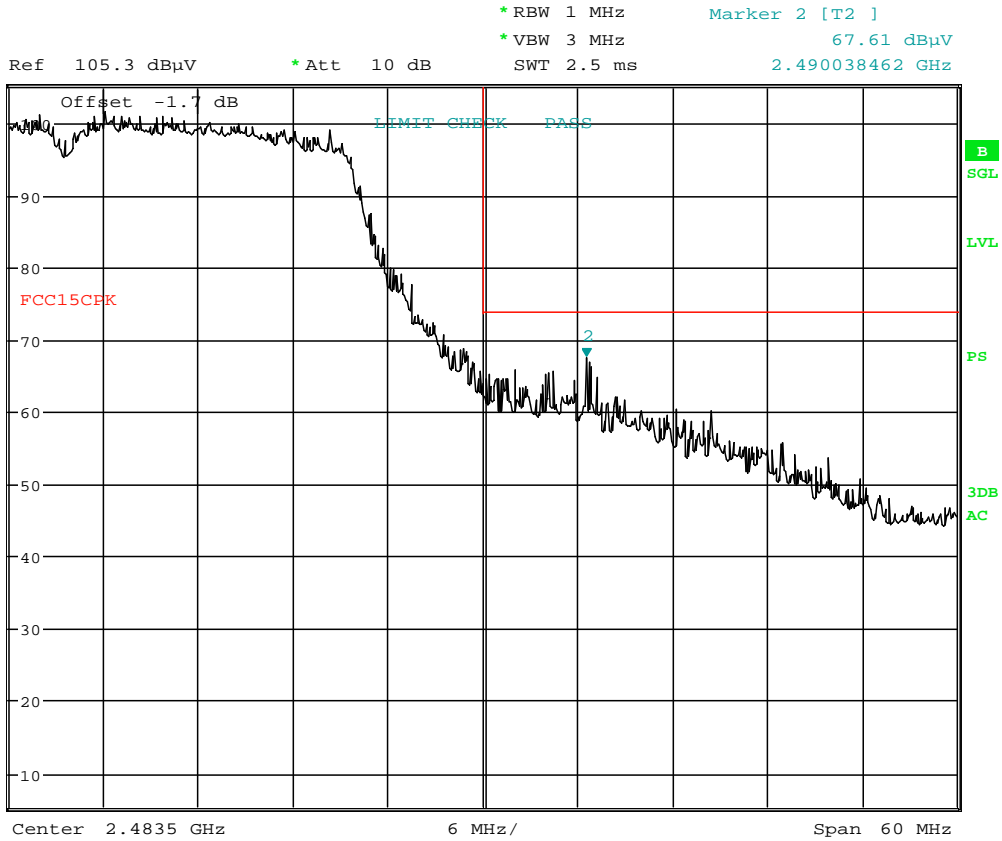

Date: 13.FEB.2017 16:53:47

Plot 7-216. Radiated Restricted Upper Band Edge Measurement (Peak)

FCC ID: A3LETWV531		FCC Pt. 15.247 802.11b/g/n/ac MEASUREMENT REPORT (CERTIFICATION)		Approved by: Quality Manager
Test Report S/N: 1M1705180171-02.A3L	Test Dates: 11/23/2016-02/17/2017	EUT Type: Indoor Access Point	Page 166 of 196	

7.8.2 MIMO Radiated Restricted Band Edge Measurements §15.205 §15.209

The radiated restricted band edge measurements are measured with an EMI test receiver connected to the receive antenna while the EUT is transmitting.

Worst Case Mode: 802.11n (20MHz BW)
 Worst Case Transfer Rate: MCS8
 Distance of Measurements: 3 Meters
 Operating Frequency: 2412MHz
 Channel: 1

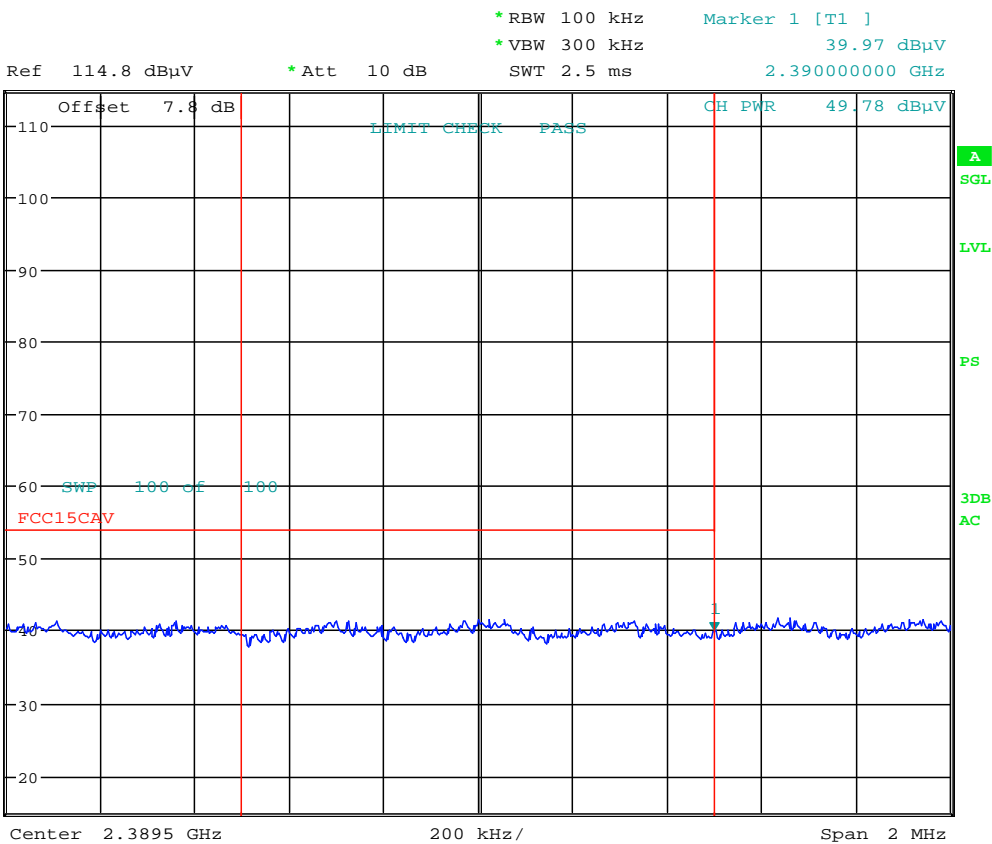

Date: 5.DEC.2016 09:44:45

Plot 7-217. Radiated Restricted Lower Band Edge Measurement (Average)

FCC ID: A3LETWV531		FCC Pt. 15.247 802.11b/g/n/ac MEASUREMENT REPORT (CERTIFICATION)		Approved by: Quality Manager
Test Report S/N: 1M1705180171-02.A3L	Test Dates: 11/23/2016-02/17/2017	EUT Type: Indoor Access Point	Page 167 of 196	

MIMO Radiated Restricted Band Edge Measurements

§15.205 §15.209

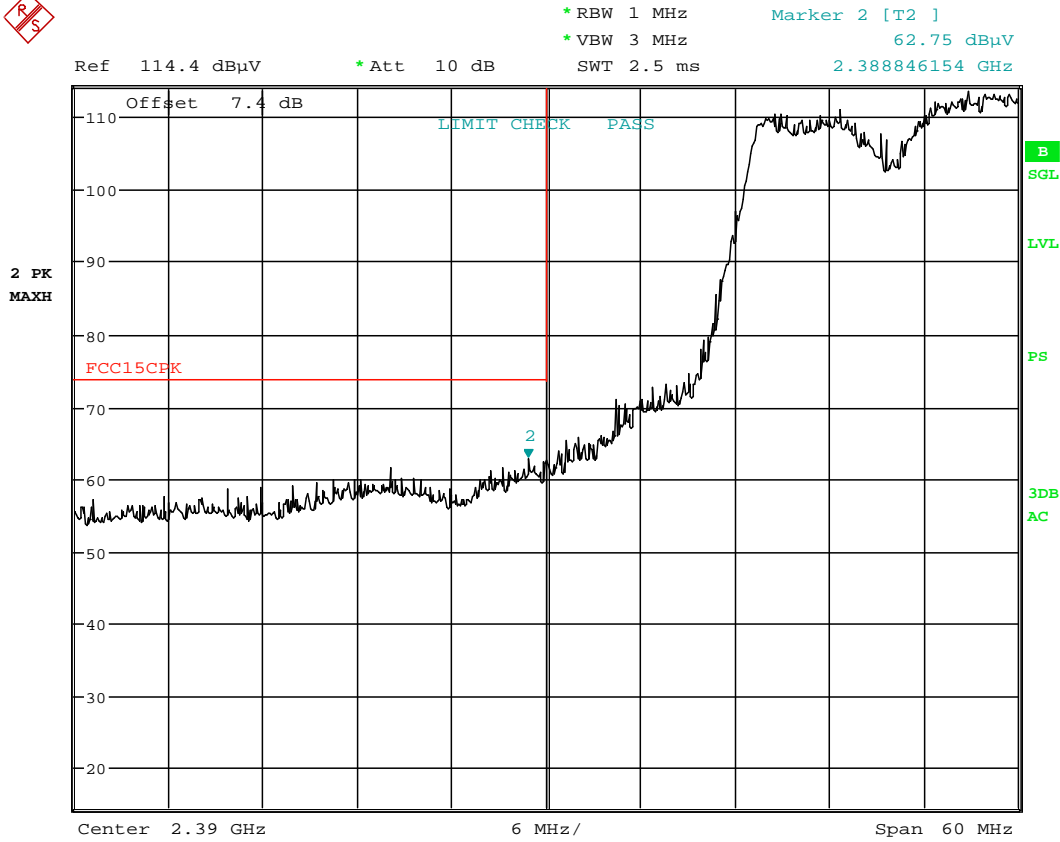

Date: 5.DEC.2016 09:46:07

Plot 7-218. Radiated Restricted Lower Band Edge Measurement (Peak)

FCC ID: A3LETWV531		FCC Pt. 15.247 802.11b/g/n/ac MEASUREMENT REPORT (CERTIFICATION)		Approved by: Quality Manager
Test Report S/N: 1M1705180171-02.A3L	Test Dates: 11/23/2016-02/17/2017	EUT Type: Indoor Access Point		Page 168 of 196

MIMO Radiated Restricted Band Edge Measurements

§15.205 §15.209

The radiated restricted band edge measurements are measured with an EMI test receiver connected to the receive antenna while the EUT is transmitting.

Worst Case Mode: 802.11n/ac (40MHz BW)
 Worst Case Transfer Rate: MCS8
 Distance of Measurements: 3 Meters
 Operating Frequency: 2422MHz
 Channel: 3

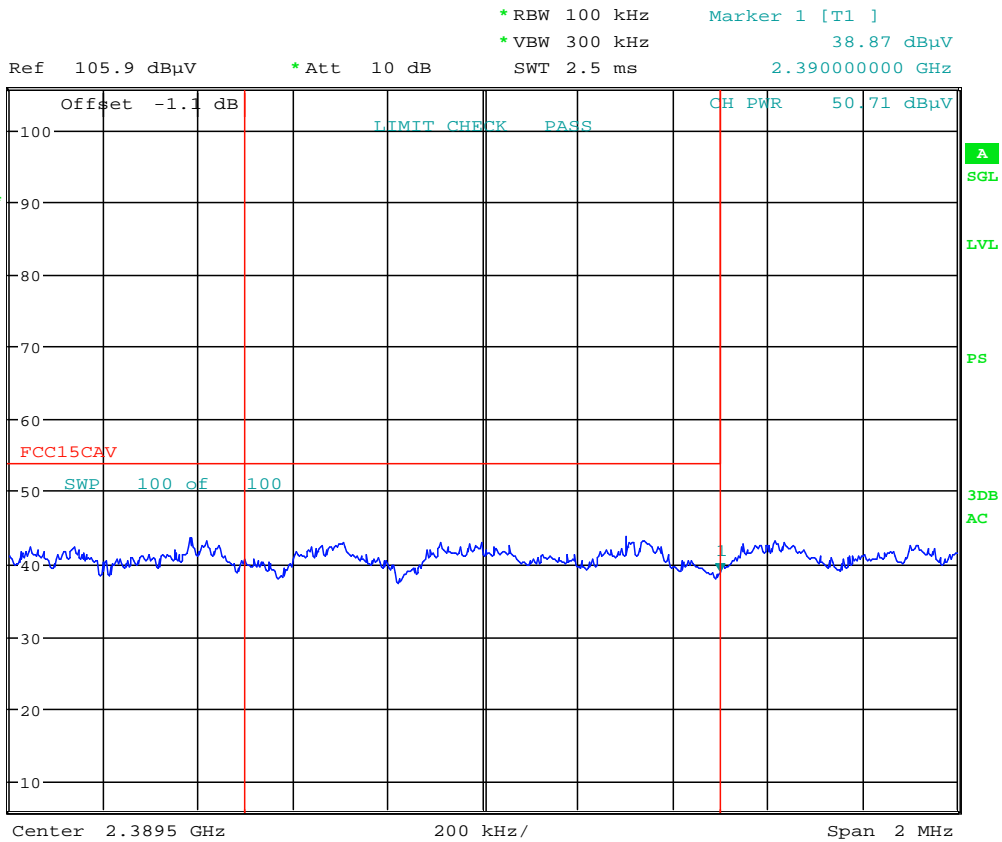

Date: 13.FEB.2017 20:04:00

Plot 7-219. Radiated Restricted Lower Band Edge Measurement (Average)

FCC ID: A3LETWV531		FCC Pt. 15.247 802.11b/g/n/ac MEASUREMENT REPORT (CERTIFICATION)		Approved by: Quality Manager
Test Report S/N: 1M1705180171-02.A3L	Test Dates: 11/23/2016-02/17/2017	EUT Type: Indoor Access Point		Page 169 of 196

MIMO Radiated Restricted Band Edge Measurements

§15.205 §15.209

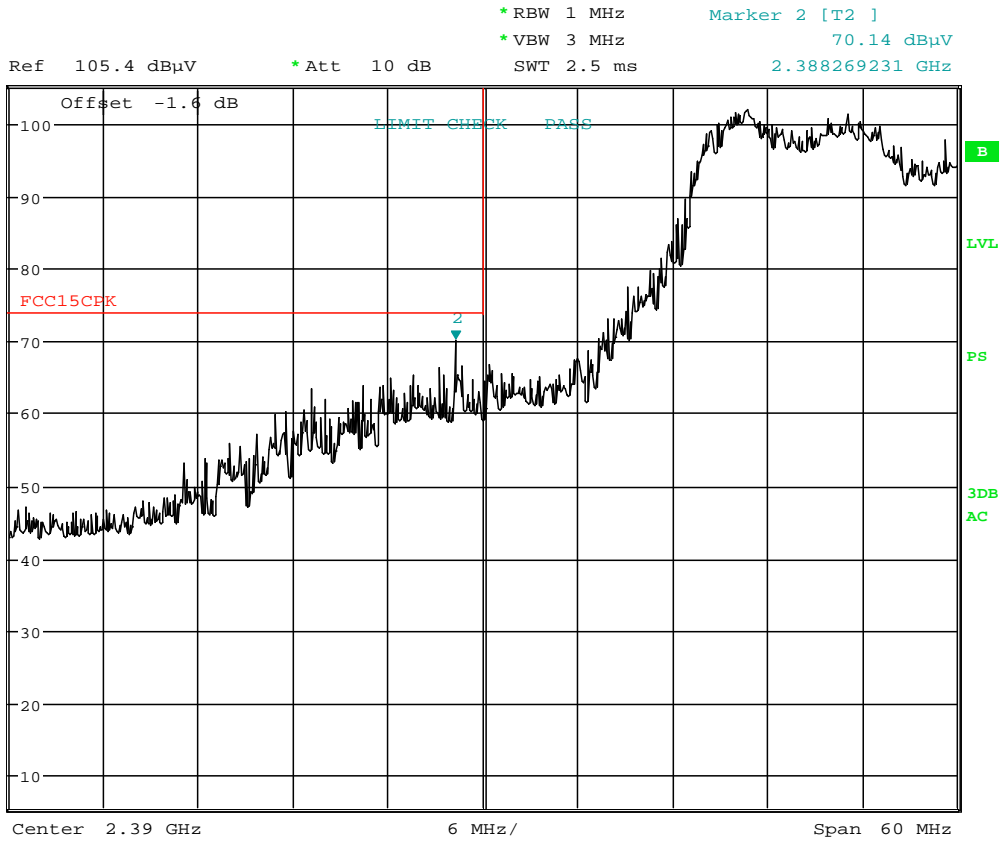

Date: 13.FEB.2017 20:04:52

Plot 7-220. Radiated Restricted Lower Band Edge Measurement (Peak)

FCC ID: A3LETWV531		FCC Pt. 15.247 802.11b/g/n/ac MEASUREMENT REPORT (CERTIFICATION)		Approved by: Quality Manager
Test Report S/N: 1M1705180171-02.A3L	Test Dates: 11/23/2016-02/17/2017	EUT Type: Indoor Access Point	Page 170 of 196	

© 2017 PCTEST Engineering Laboratory, Inc.

V 6.5

05/19/2017

MIMO Radiated Restricted Band Edge Measurements

§15.205 §15.209

Worst Case Mode: 802.11n (20MHz BW)

Worst Case Transfer Rate: MCS8

Distance of Measurements: 3 Meters

Operating Frequency: 2462MHz

Channel: 11

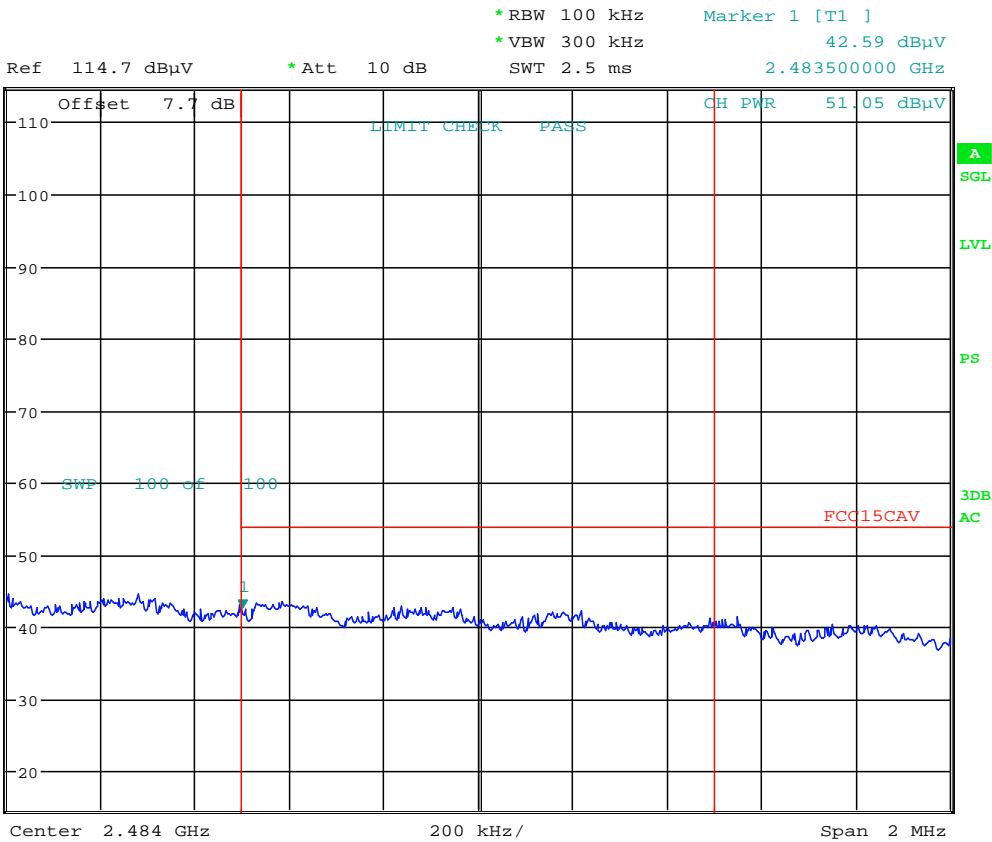

Date: 5.DEC.2016 09:52:40

Plot 7-221. Radiated Restricted Upper Band Edge Measurement (Average)

FCC ID: A3LETWV531		FCC Pt. 15.247 802.11b/g/n/ac MEASUREMENT REPORT (CERTIFICATION)		Approved by: Quality Manager
Test Report S/N: 1M1705180171-02.A3L	Test Dates: 11/23/2016-02/17/2017	EUT Type: Indoor Access Point	Page 171 of 196	

MIMO Radiated Restricted Band Edge Measurements

§15.205 §15.209

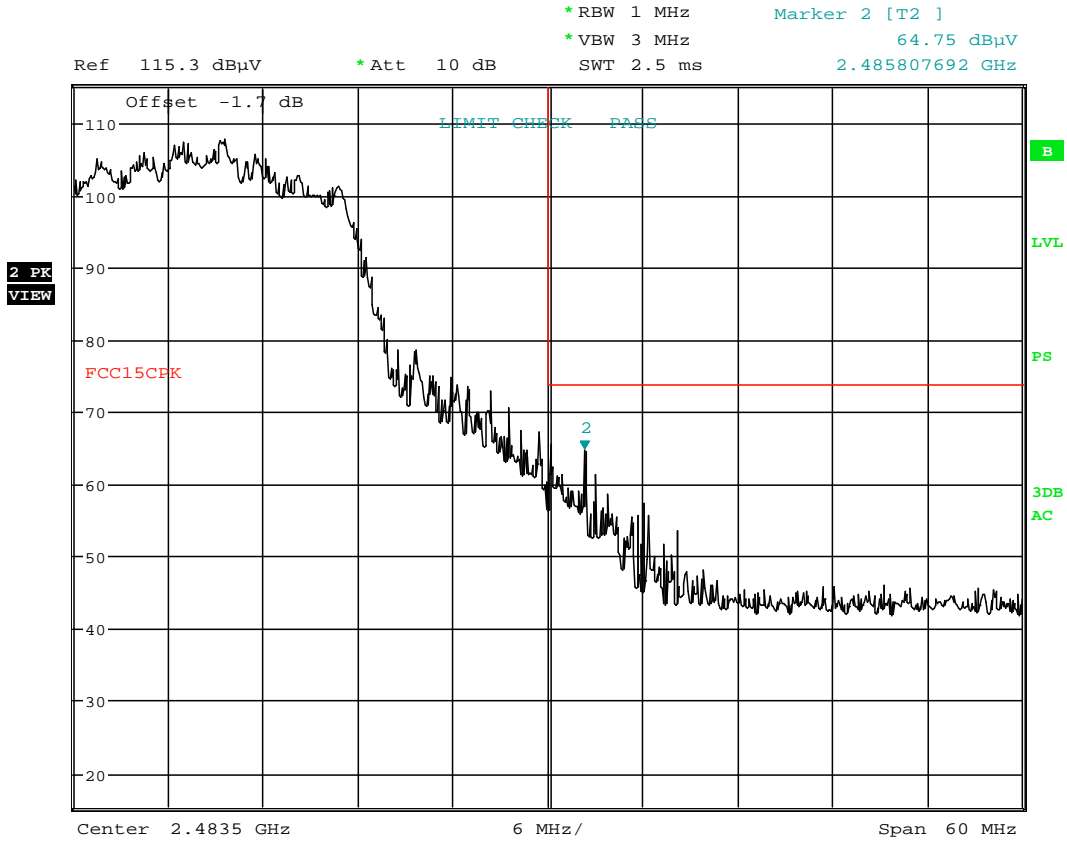

Date: 1.FEB.2017 12:36:25

Plot 7-222. Radiated Restricted Upper Band Edge Measurement (Peak)

FCC ID: A3LETWV531		FCC Pt. 15.247 802.11b/g/n/ac MEASUREMENT REPORT (CERTIFICATION)		Approved by: Quality Manager
Test Report S/N: 1M1705180171-02.A3L	Test Dates: 11/23/2016-02/17/2017	EUT Type: Indoor Access Point		Page 172 of 196

MIMO Radiated Restricted Band Edge Measurements

§15.205 §15.209

Worst Case Mode: 802.11n/ac (40MHz BW)

Worst Case Transfer Rate: MCS8

Distance of Measurements: 3 Meters

Operating Frequency: 2457MHz

Channel: 10

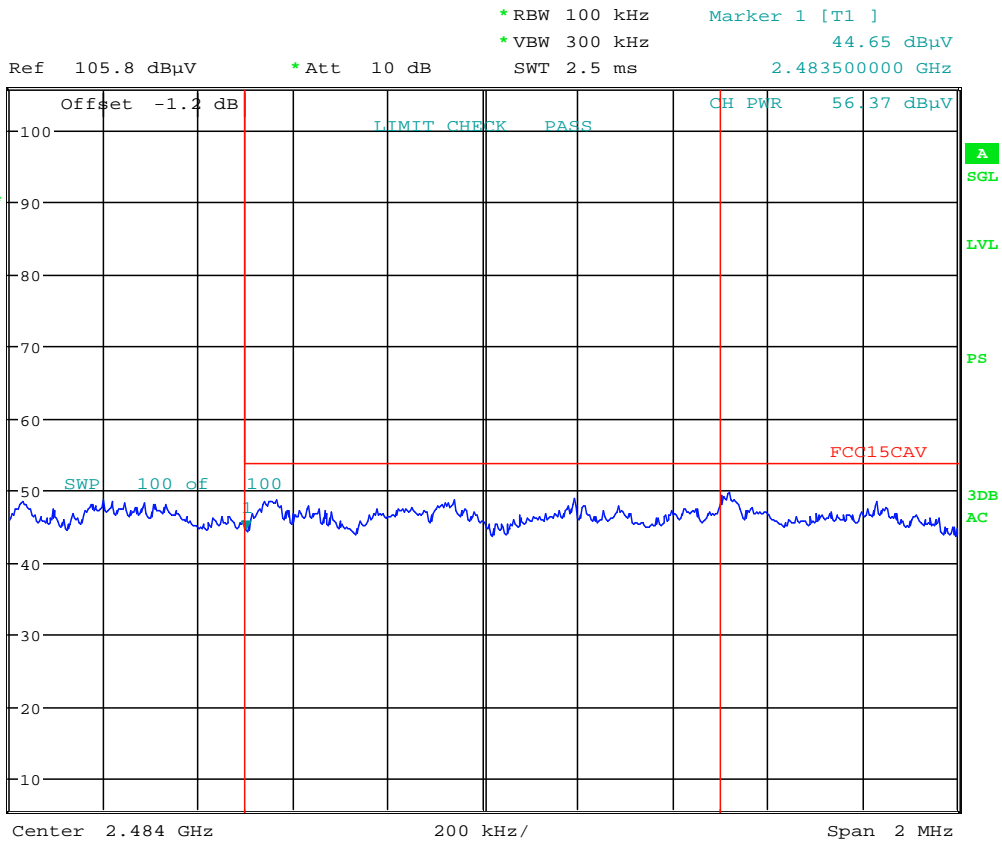

Date: 13.FEB.2017 19:01:51

Plot 7-223. Radiated Restricted Upper Band Edge Measurement (Average)

FCC ID: A3LETWV531		FCC Pt. 15.247 802.11b/g/n/ac MEASUREMENT REPORT (CERTIFICATION)		Approved by: Quality Manager
Test Report S/N: 1M1705180171-02.A3L	Test Dates: 11/23/2016-02/17/2017	EUT Type: Indoor Access Point	Page 173 of 196	

MIMO Radiated Restricted Band Edge Measurements

§15.205 §15.209

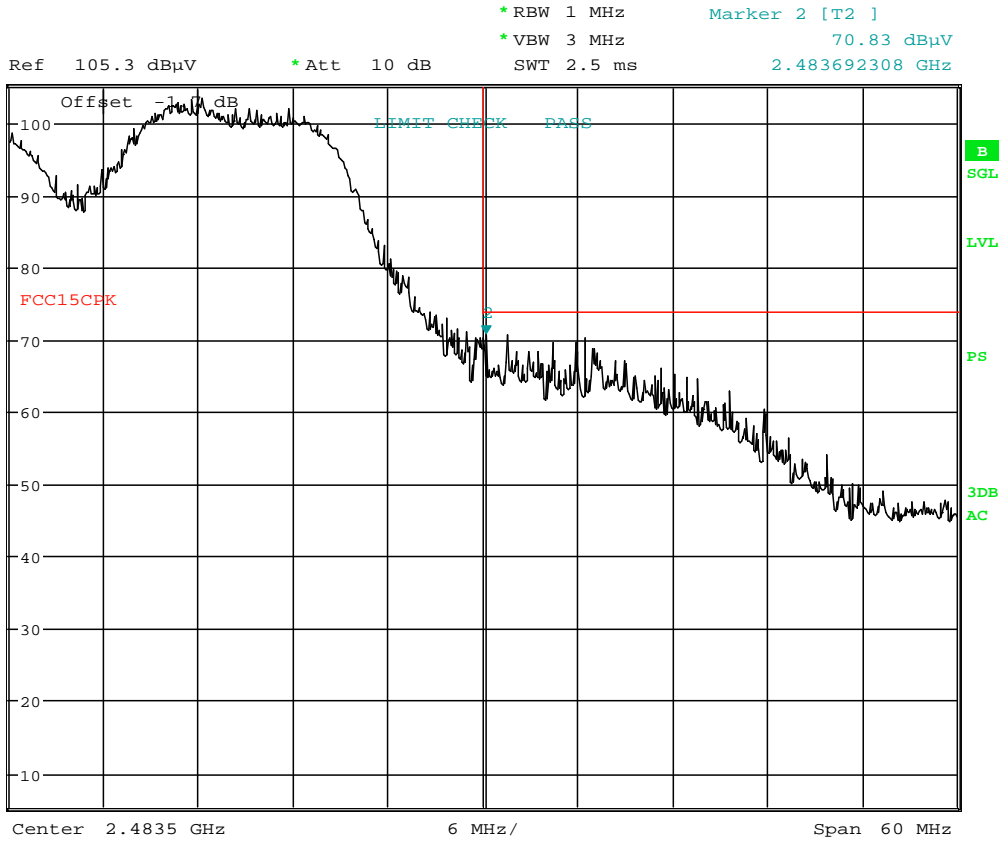

Date: 13.FEB.2017 19:10:57

Plot 7-224. Radiated Restricted Upper Band Edge Measurement (Peak)

FCC ID: A3LETWV531		FCC Pt. 15.247 802.11b/g/n/ac MEASUREMENT REPORT (CERTIFICATION)		Approved by: Quality Manager
Test Report S/N: 1M1705180171-02.A3L	Test Dates: 11/23/2016-02/17/2017	EUT Type: Indoor Access Point		Page 174 of 196

7.9 Radiated Spurious Emissions Measurements – Below 1GHz

§15.209

Test Overview and Limit

All out of band radiated spurious emissions are measured with a spectrum analyzer connected to a receive antenna while the EUT is operating at its maximum duty cycle, at maximum power, and at the appropriate frequencies. All data rates and modes were investigated for radiated spurious emissions. Only the radiated emissions of the configuration that produced the worst case emissions are reported in this section.

All out of band emissions appearing in a restricted band as specified in Section 15.205 of the Title 47 CFR must not exceed the limits shown in Table 7-38 per Section 15.209.

Frequency	Field Strength [$\mu\text{V/m}$]	Measured Distance [Meters]
0.009 – 0.490 MHz	2400/F (kHz)	300
0.490 – 1.705 MHz	24000/F (kHz)	30
1.705 – 30.00 MHz	30	30
30.00 – 88.00 MHz	100	3
88.00 – 216.0 MHz	150	3
216.0 – 960.0 MHz	200	3
Above 960.0 MHz	500	3

Table 7-38. Radiated Limits



Test Procedures Used

ANSI C63.10-2013

Test Settings

Quasi-Peak Field Strength Measurements

1. Analyzer center frequency was set to the frequency of the radiated spurious emission of interest
2. RBW = 120kHz (for emissions from 30MHz – 1GHz)
3. Detector = quasi-peak
4. Sweep time = auto couple
5. Trace mode = max hold
6. Trace was allowed to stabilize

FCC ID: A3LETWV531		FCC Pt. 15.247 802.11b/g/n/ac MEASUREMENT REPORT (CERTIFICATION)		Approved by: Quality Manager
Test Report S/N: 1M1705180171-02.A3L	Test Dates: 11/23/2016-02/17/2017	EUT Type: Indoor Access Point	Page 175 of 196	

Test Setup

The EUT and measurement equipment were set up as shown in the diagrams below.

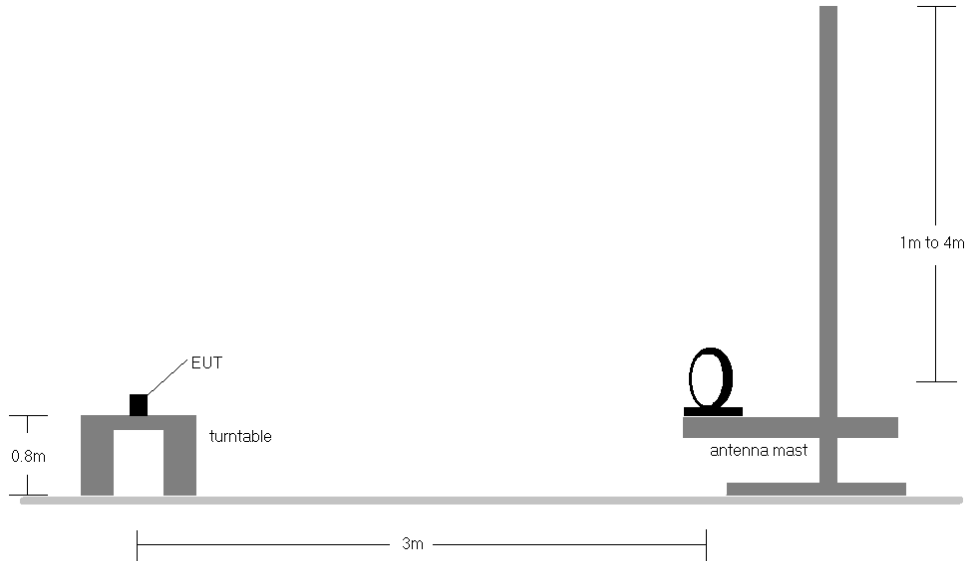

Figure 7-7. Radiated Test Setup < 30Mhz

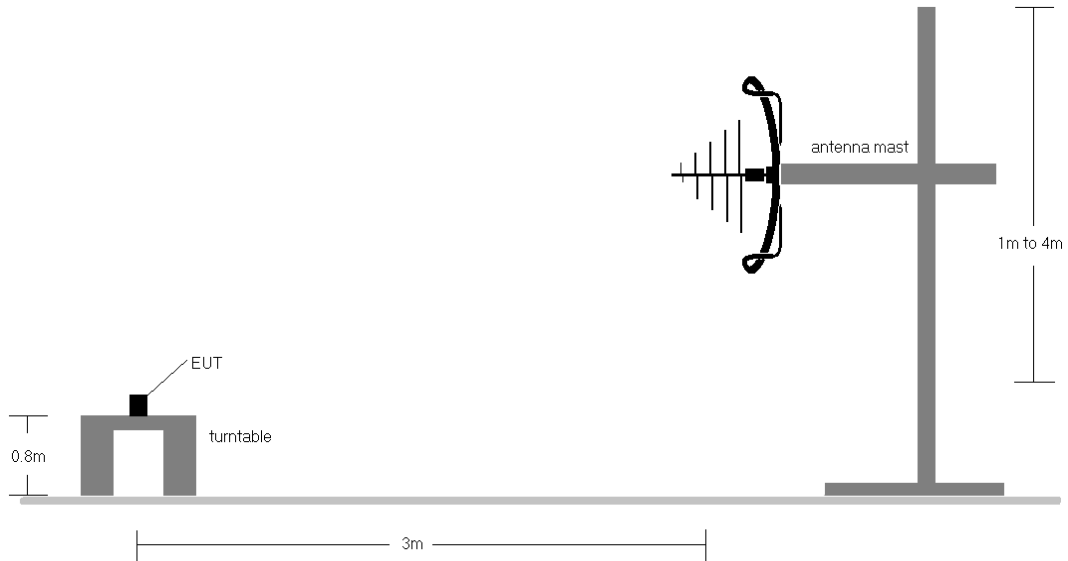





Figure 7-8. Radiated Test Setup < 1GHz

FCC ID: A3LETWV531		FCC Pt. 15.247 802.11b/g/n/ac MEASUREMENT REPORT (CERTIFICATION)		Approved by: Quality Manager
Test Report S/N: 1M1705180171-02.A3L	Test Dates: 11/23/2016-02/17/2017	EUT Type: Indoor Access Point	Page 176 of 196	

Test Notes

1. All emissions lying in restricted bands specified in §15.205 are below the limit shown in Table 7-38.
2. The broadband receive antenna is manipulated through vertical and horizontal polarizations during the tests. The EUT is manipulated through three orthogonal planes.
3. This unit was tested with its standard battery.
4. The spectrum is investigated using a peak detector and final measurements are recorded using CISPR quasi peak detector. The worst-case emissions are reported however emissions whose levels were not within 20dB of the respective limits were not reported.
5. Emissions were measured at a 3 meter test distance.
6. Emissions are investigated while operating on the center channel of the mode, band, and modulation that produced the worst case results during the transmitter spurious emissions testing.
7. No spurious emissions were detected within 20dB of the limit below 30MHz.
8. The results recorded using the broadband antenna is known to correlate with the results obtained by using a tuned dipole with an acceptable degree of accuracy. The VSWR for the measurement antenna was found to be less than 2:1.
9. The wide spectrum spurious emissions plots shown on the following pages are used only for the purpose of emission identification. There were no emissions detected in the 30MHz – 1GHz frequency range, as shown in the subsequent plots.

FCC ID: A3LETWV531		FCC Pt. 15.247 802.11b/g/n/ac MEASUREMENT REPORT (CERTIFICATION)		Approved by: Quality Manager
Test Report S/N: 1M1705180171-02.A3L	Test Dates: 11/23/2016-02/17/2017	EUT Type: Indoor Access Point		Page 177 of 196

Antenna-1 Radiated Spurious Emissions Measurements (Below 1GHz)

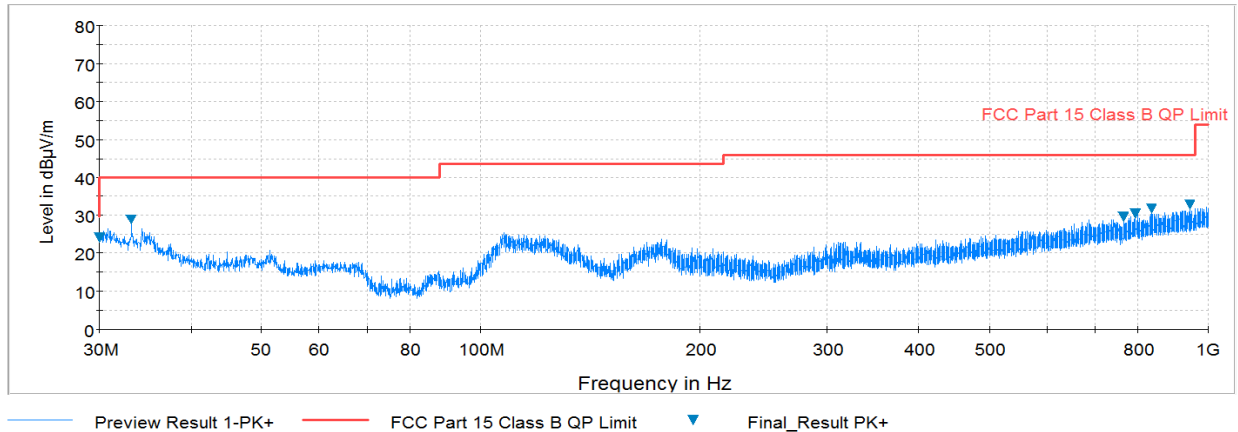

§15.209

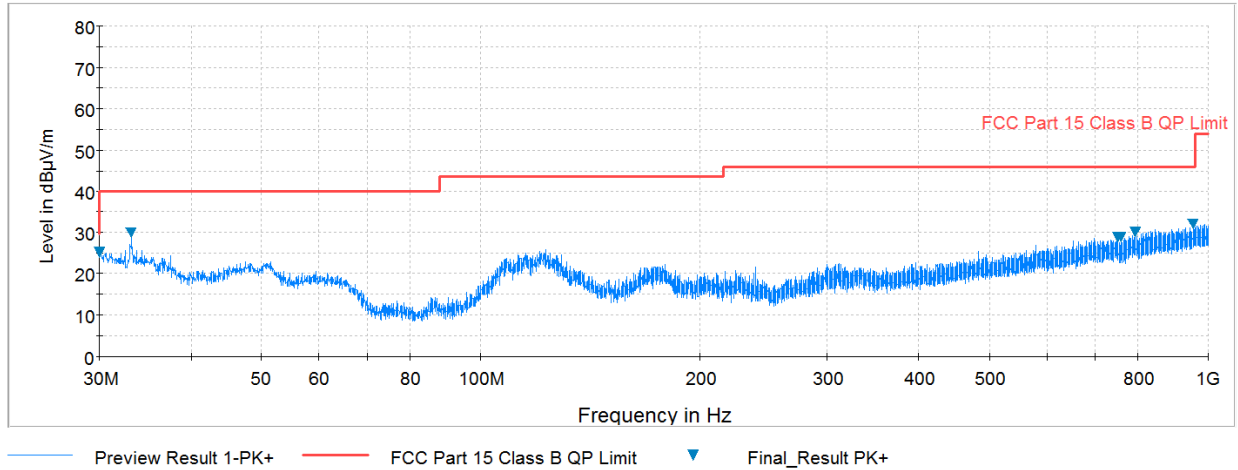

Plot 7-225. Radiated Spurious Plot below 1GHz (Pol. H)



Plot 7-226. Radiated Spurious Plot below 1GHz (Pol. V)

FCC ID: A3LETWV531		FCC Pt. 15.247 802.11b/g/n/ac MEASUREMENT REPORT (CERTIFICATION)		Approved by: Quality Manager
Test Report S/N: 1M1705180171-02.A3L	Test Dates: 11/23/2016-02/17/2017	EUT Type: Indoor Access Point	Page 178 of 196	

Antenna-2 Radiated Spurious Emissions Measurements (Below 1GHz)

§15.209

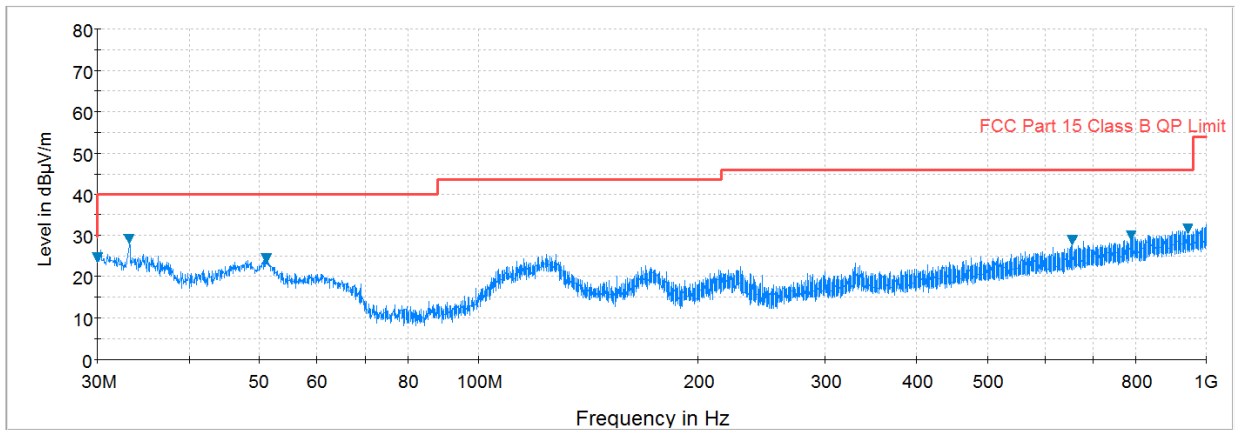

Preview Result 1-PK+ FCC Part 15 Class B QP Limit Final_Result PK+

Plot 7-227. Radiated Spurious Plot below 1GHz (Pol. H)

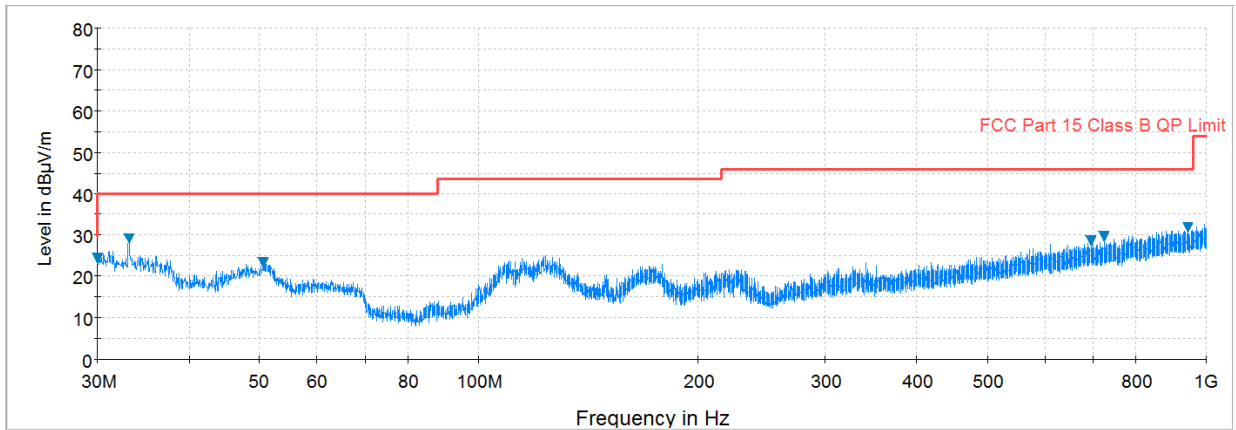

Preview Result 1-PK+ FCC Part 15 Class B QP Limit Final_Result PK+

Plot 7-228. Radiated Spurious Plot below 1GHz (Pol. V)

FCC ID: A3LETWV531		FCC Pt. 15.247 802.11b/g/n/ac MEASUREMENT REPORT (CERTIFICATION)		Approved by: Quality Manager
Test Report S/N: 1M1705180171-02.A3L	Test Dates: 11/23/2016-02/17/2017	EUT Type: Indoor Access Point		Page 179 of 196

Antenna-3 Radiated Spurious Emissions Measurements (Below 1GHz)

§15.209

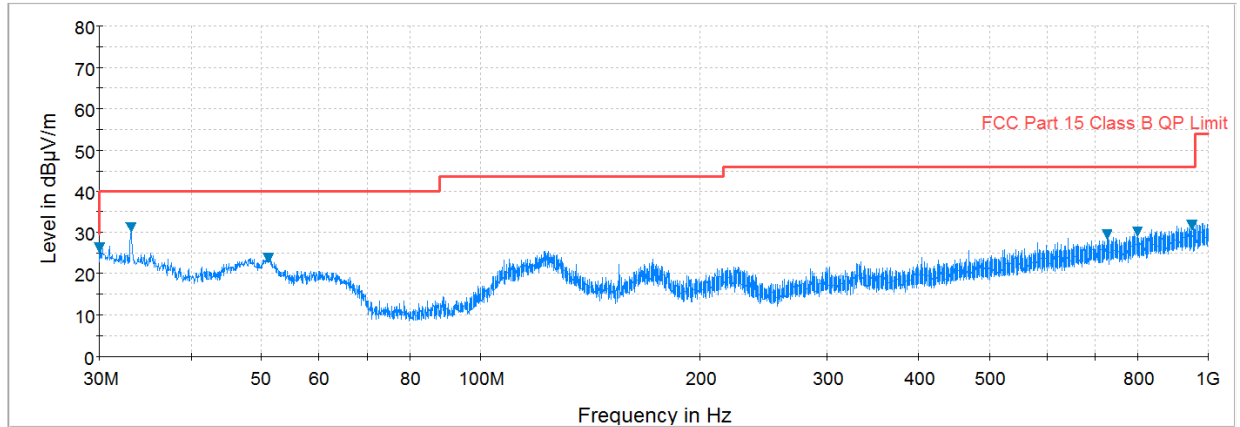

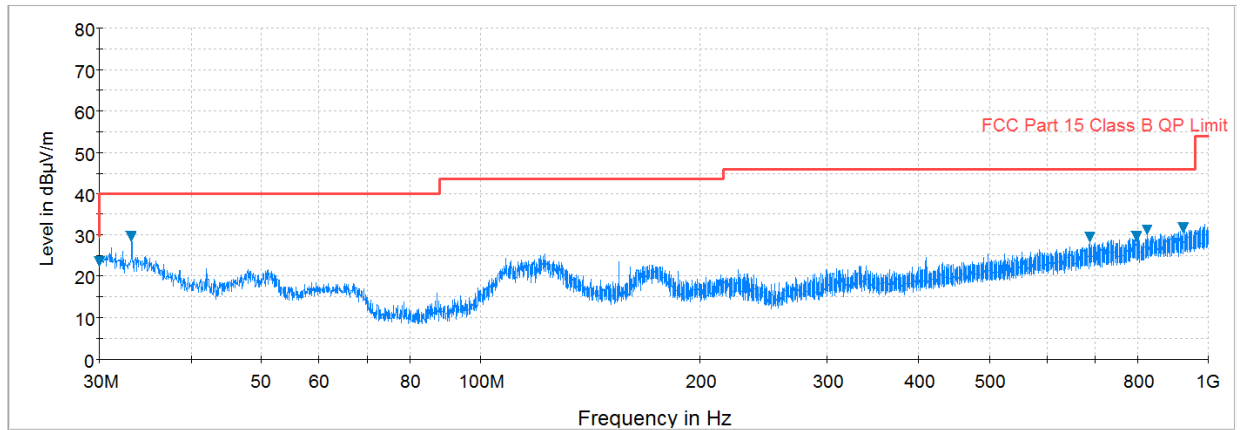

Preview Result 1-PK+ FCC Part 15 Class B QP Limit Final_Result PK+

Plot 7-229. Radiated Spurious Plot below 1GHz (Pol. H)



Preview Result 1-PK+ FCC Part 15 Class B QP Limit Final_Result PK+

Plot 7-230. Radiated Spurious Plot below 1GHz (Pol. V)

FCC ID: A3LETWV531		FCC Pt. 15.247 802.11b/g/n/ac MEASUREMENT REPORT (CERTIFICATION)		Approved by: Quality Manager
Test Report S/N: 1M1705180171-02.A3L	Test Dates: 11/23/2016-02/17/2017	EUT Type: Indoor Access Point	Page 180 of 196	

Antenna-4 Radiated Spurious Emissions Measurements (Below 1GHz)

§15.209

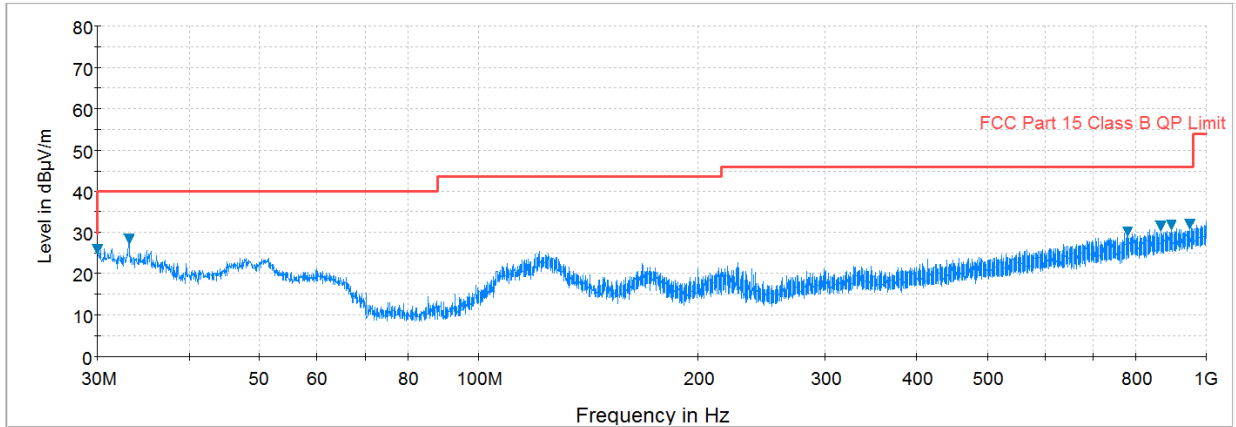

Preview Result 1-PK+ FCC Part 15 Class B QP Limit Final_Result PK+

Plot 7-231. Radiated Spurious Plot below 1GHz (Pol. H)

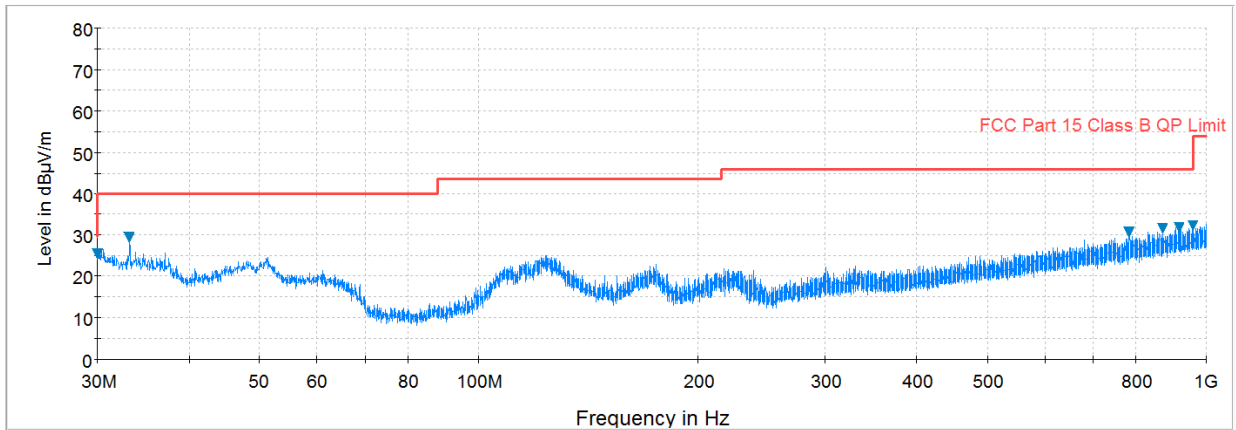

Preview Result 1-PK+ FCC Part 15 Class B QP Limit Final_Result PK+

Plot 7-232. Radiated Spurious Plot below 1GHz (Pol. V)

FCC ID: A3LETWV531		FCC Pt. 15.247 802.11b/g/n/ac MEASUREMENT REPORT (CERTIFICATION)		Approved by: Quality Manager
Test Report S/N: 1M1705180171-02.A3L	Test Dates: 11/23/2016-02/17/2017	EUT Type: Indoor Access Point		Page 181 of 196

7.10 Line-Conducted Test Data

§15.207

Test Overview and Limit

All AC line conducted spurious emissions are measured with a receiver connected to a grounded LISN while the EUT is operating at its maximum duty cycle, at maximum power, and at the appropriate frequencies. All data rates and modes were investigated for conducted spurious emissions. Only the conducted emissions of the configuration that produced the worst case emissions are reported in this section.

All conducted emissions must not exceed the limits shown in the table below, per Section 15.207.

Frequency of emission (MHz)	Conducted Limit (dB μ V)	
	Quasi-peak	Average
0.15 – 0.5	66 to 56*	56 to 46*
0.5 – 5	56	46
5 – 30	60	50

Table 7-39. Conducted Limits

*Decreases with the logarithm of the frequency.

Test Procedures Used

ANSI C63.10-2013, Section 6.2



Test Settings

Quasi-Peak Field Strength Measurements

1. Analyzer center frequency was set to the frequency of the spurious emission of interest
2. RBW = 9kHz (for emissions from 150kHz – 30MHz)
3. Detector = quasi-peak
4. Sweep time = auto couple
5. Trace mode = max hold
6. Trace was allowed to stabilize

Average Field Strength Measurements

1. Analyzer center frequency was set to the frequency of the spurious emission of interest
2. RBW = 9kHz (for emissions from 150kHz – 30MHz)
3. Detector = RMS
4. Sweep time = auto couple
5. Trace mode = max hold
6. Trace was allowed to stabilize

FCC ID: A3LETWV531		FCC Pt. 15.247 802.11b/g/n/ac MEASUREMENT REPORT (CERTIFICATION)		Approved by: Quality Manager
Test Report S/N: 1M1705180171-02.A3L	Test Dates: 11/23/2016-02/17/2017	EUT Type: Indoor Access Point	Page 182 of 196	

Test Setup

The EUT and measurement equipment were set up as shown in the diagram below.

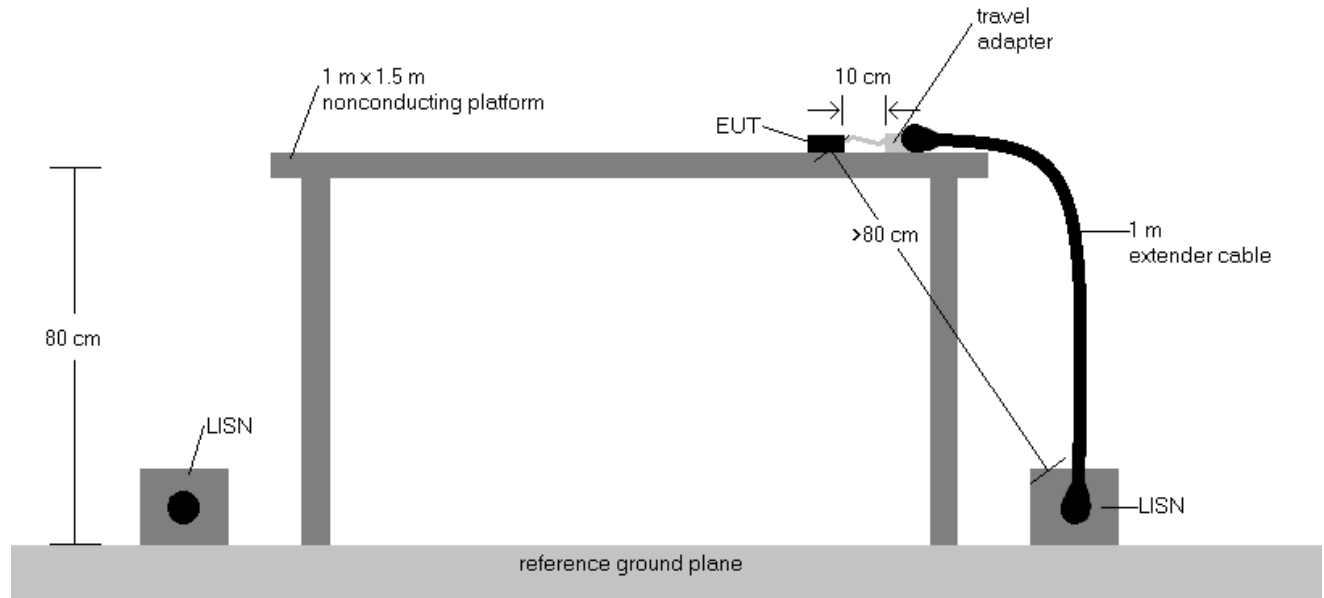



Figure 7-9. Test Instrument & Measurement Setup

Test Notes

1. All modes of operation were investigated and the worst-case emissions are reported using mid channel. The emissions found were not affected by the choice of channel used during testing.
2. The limit for an intentional radiator from 150kHz to 30MHz are specified in 15.207.
3. $\text{Corr. (dB)} = \text{Cable loss (dB)} + \text{LISN insertion factor (dB)}$
4. $\text{QP/AV Level (dB}\mu\text{V)} = \text{QP/AV Analyzer/Receiver Level (dB}\mu\text{V)} + \text{Corr. (dB)}$
5. $\text{Margin (dB)} = \text{QP/AV Limit (dB}\mu\text{V)} - \text{QP/AV Level (dB}\mu\text{V)}$
6. Traces shown in plot are made using a peak detector.
7. Deviations to the Specifications: None.

FCC ID: A3LETWV531		FCC Pt. 15.247 802.11b/g/n/ac MEASUREMENT REPORT (CERTIFICATION)		Approved by: Quality Manager
Test Report S/N: 1M1705180171-02.A3L	Test Dates: 11/23/2016-02/17/2017	EUT Type: Indoor Access Point		Page 183 of 196

Antenna 1 Line-Conducted Test Data

§15.207

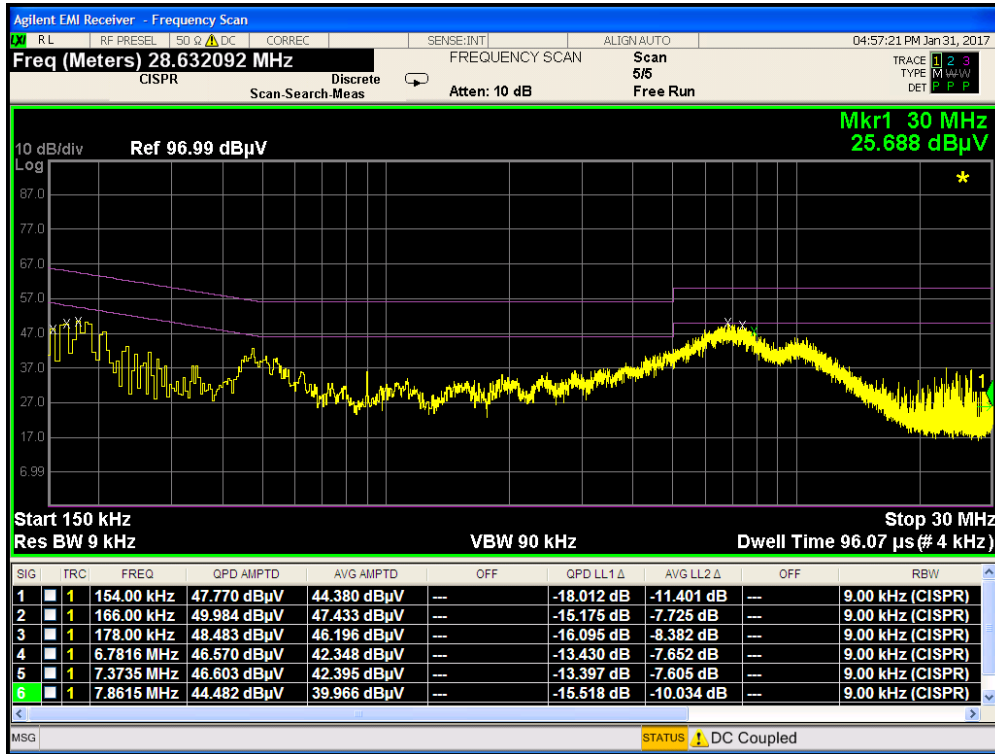

Plot 7-233. Line Conducted Plot with 802.11b (L1)

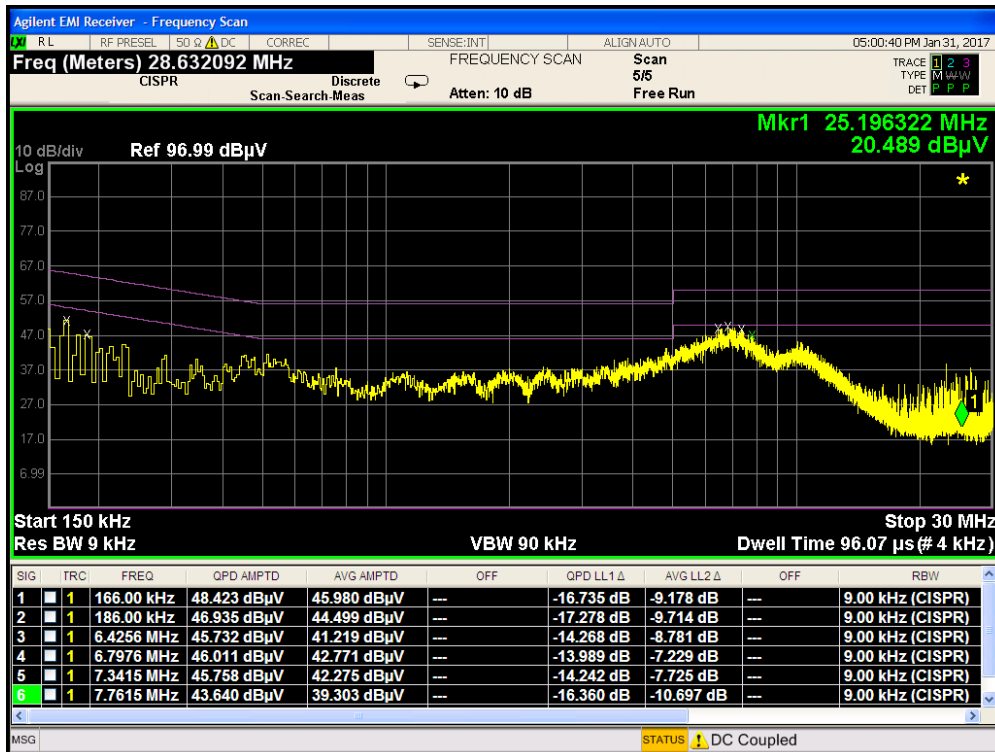

Plot 7-234. Line Conducted Plot with 802.11b (N)

FCC ID: A3LETWV531		FCC Pt. 15.247 802.11b/g/n/ac MEASUREMENT REPORT (CERTIFICATION)		Approved by: Quality Manager
Test Report S/N: 1M1705180171-02.A3L	Test Dates: 11/23/2016-02/17/2017	EUT Type: Indoor Access Point		Page 184 of 196

Antenna 2 Line-Conducted Test Data

\$15.207



Plot 7-235. Line Conducted Plot with 802.11b (L1)

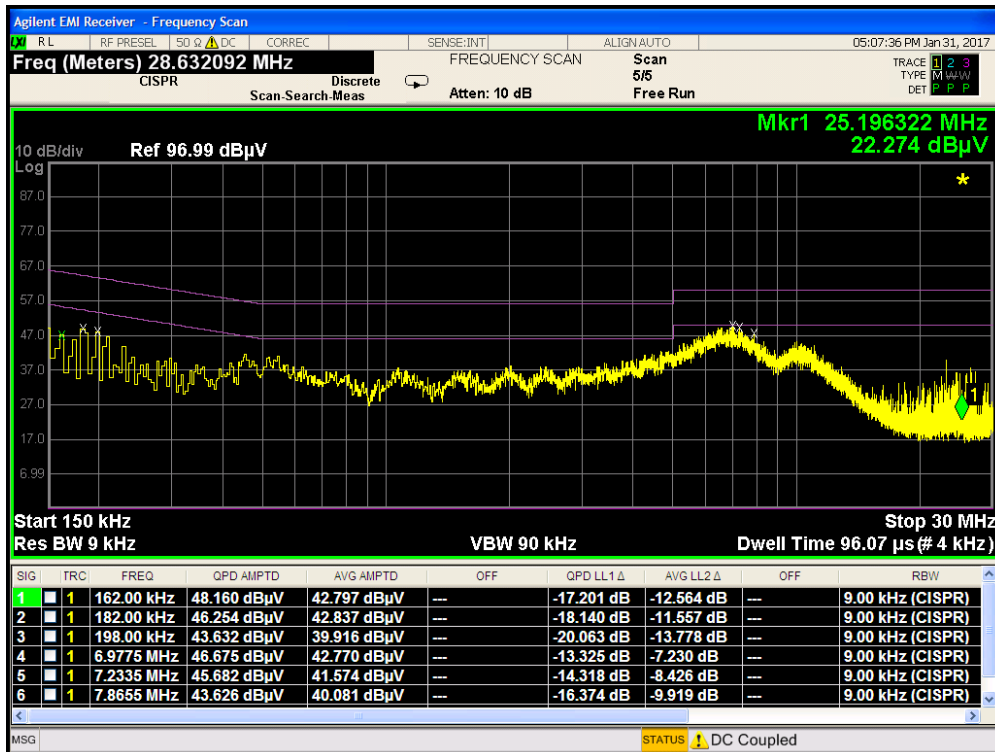

Plot 7-236. Line Conducted Plot with 802.11b (N)

FCC ID: A3LETWV531		FCC Pt. 15.247 802.11b/g/n/ac MEASUREMENT REPORT (CERTIFICATION)		Approved by: Quality Manager
Test Report S/N: 1M1705180171-02.A3L	Test Dates: 11/23/2016-02/17/2017	EUT Type: Indoor Access Point		Page 185 of 196

Antenna 3 Line-Conducted Test Data

§15.207



Plot 7-237. Line Conducted Plot with 802.11b (L1)

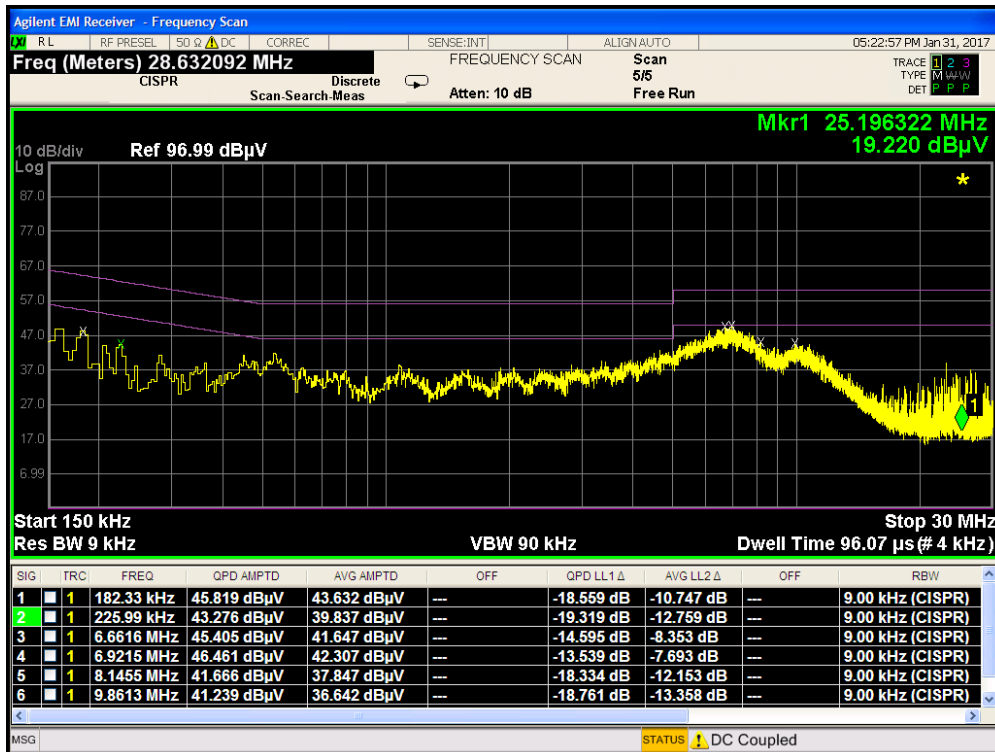

Plot 7-238. Line Conducted Plot with 802.11b (N)

FCC ID: A3LETWV531		FCC Pt. 15.247 802.11b/g/n/ac MEASUREMENT REPORT (CERTIFICATION)		Approved by: Quality Manager
Test Report S/N: 1M1705180171-02.A3L	Test Dates: 11/23/2016-02/17/2017	EUT Type: Indoor Access Point		Page 186 of 196

Antenna 4 Line-Conducted Test Data

\$15.207

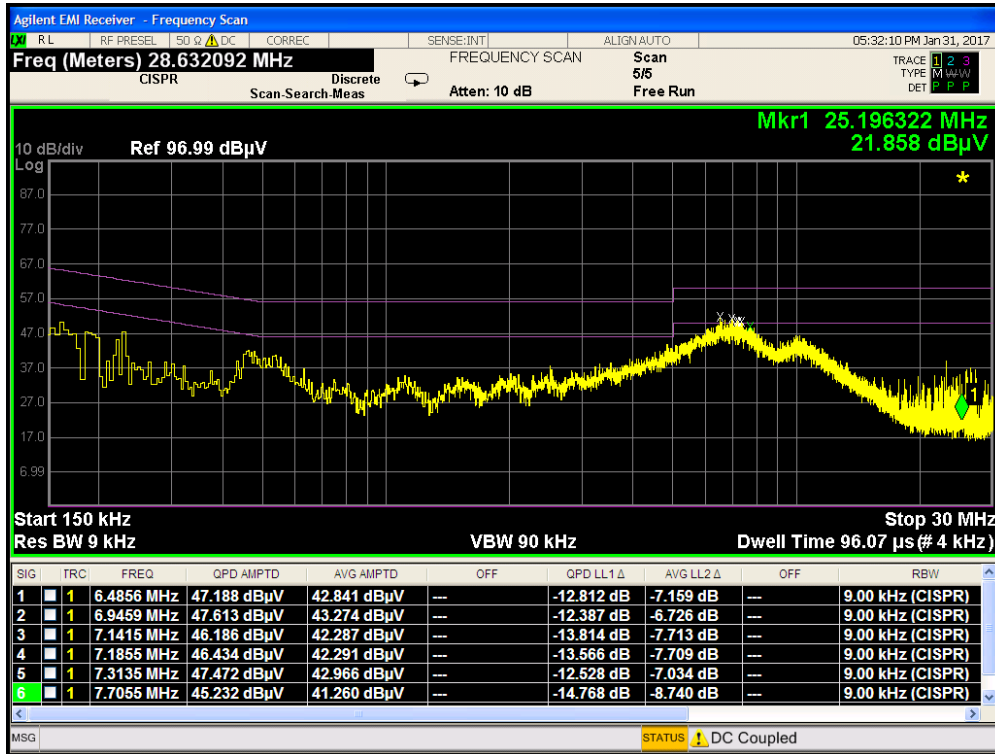

Plot 7-239. Line Conducted Plot with 802.11b (L1)

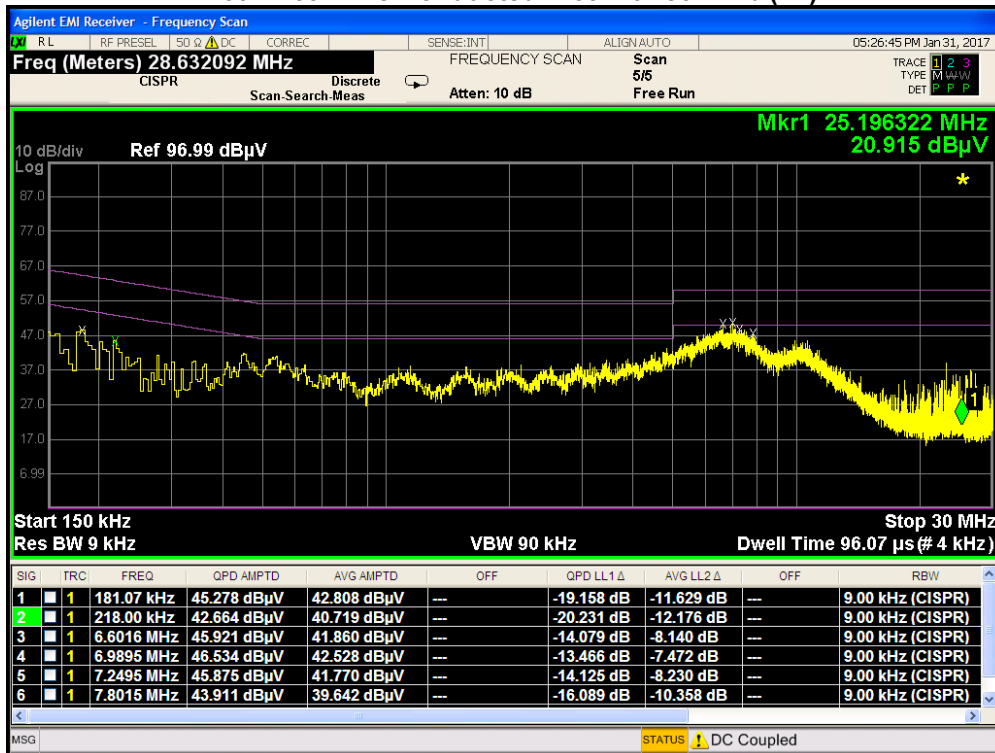



Plot 7-240. Line Conducted Plot with 802.11b (N)

FCC ID: A3LETWV531		FCC Pt. 15.247 802.11b/g/n/ac MEASUREMENT REPORT (CERTIFICATION)		Approved by: Quality Manager
Test Report S/N: 1M1705180171-02.A3L	Test Dates: 11/23/2016-02/17/2017	EUT Type: Indoor Access Point		Page 187 of 196

8.0 CONCLUSION

The data collected relate only the item(s) tested and show that the **Samsung Indoor Access Point FCC ID: A3LETWV531** is in compliance with Part 15C of the FCC Rules.

FCC ID: A3LETWV531		FCC Pt. 15.247 802.11b/g/n/ac MEASUREMENT REPORT (CERTIFICATION)		Approved by: Quality Manager
Test Report S/N: 1M1705180171-02.A3L	Test Dates: 11/23/2016-02/17/2017	EUT Type: Indoor Access Point	Page 188 of 196	

APPENDIX A. 802.11G DUAL TX



A.1 Summary

FCC Part Section(s)	Test Description	Test Limit	Test Condition	Test Result	Reference
TRANSMITTER MODE (TX)					
15.247(b)(3)	Transmitter Output Power	< 1 Watt	CONDUCTED	PASS	Section A.2
15.247(e)	Transmitter Power Spectral Density	< 8dBm / 3kHz Band		PASS	Section A.3
15.205 15.209	General Field Strength Limits (Restricted Bands and Radiated Emission Limits)	Emissions in restricted bands must meet the radiated limits detailed in 15.209	RADIATED	PASS	Section A.4

Table A.1-1. Summary of Test Results

Notes:

- 1) This device employs dual transmission in 802.11a and 802.11g modes using Cyclic Delay Diversity. For all test cases, the device was set to transmit from both antennas simultaneously. The data in this section demonstrates compliance to the dual-transmission requirements specified in KDB 662911 v02r01.
- 2) All data found in this section is compiled from plots found in the main body of this test report.
- 3) Since this device is able to transmit the same data through all of its antennas in a given symbol period, then, by the definition specified in KDB 662911 v02r01 Section F)1), the transmission symbols are correlated.
- 4) For CDD operation where $N_{ss} = 1$, the array gain for power density measurements is equal to $10\log(N_{ANT}/N_{SS})$ dB and the array gain for power measurements is 0dB.
- 5) For conducted spurious emissions, per KDB 662911 v02r01 Section E)3)b), the emissions on each individual output complied with its corresponding relative limit for that output, so additional testing was not required for 4x transmission operation.

FCC ID: A3LETWV531		FCC Pt. 15.247 802.11b/g/n/ac MEASUREMENT REPORT (CERTIFICATION)		Approved by: Quality Manager
Test Report S/N: 1M1705180171-02.A3L	Test Dates: 11/23/2016-02/17/2017	EUT Type: Indoor Access Point	Page 189 of 196	

A.2 Output Power Measurement



§15.247(b.3)

Test Overview

Using the “Measure and Sum” technique, the measured conducted power values were summed in linear power units then converted back to dBm. Original measured values are found in Section 7.3 of this report.

Freq [MHz]	Channel	Detector	Directional Gain [dBi]	2.4GHz Conducted Power [dBm]					Max Permissible Conducted Power [dBm]	Adjusted Limit [dBm]	Margin [dB]
				IEEE Transmission Mode							
				ANT1	ANT2	ANT3	ANT4	MIMO			
2412	1	AVG	7.83	13.99	14.24	14.22	14.23	20.19	30.00	28.17	-7.98
		PEAK	7.83	20.66	20.66	20.47	20.64	26.63	30.00	28.17	-1.54
2437	6	AVG	7.68	14.28	14.44	14.11	14.27	20.30	30.00	28.32	-8.02
		PEAK	7.68	20.79	20.66	20.43	20.54	26.63	30.00	28.32	-1.69
2462	11	AVG	7.32	12.22	12.44	12.22	12.34	18.33	30.00	28.68	-10.35
		PEAK	7.32	19.70	19.64	19.34	19.64	25.60	30.00	28.68	-3.08

Table A2-1. Dual Tx 802.11g-mode Conducted Output Power Measurements

FCC ID: A3LETWV531		FCC Pt. 15.247 802.11b/g/n/ac MEASUREMENT REPORT (CERTIFICATION)			Approved by: Quality Manager
Test Report S/N: 1M1705180171-02.A3L	Test Dates: 11/23/2016-02/17/2017	EUT Type: Indoor Access Point			Page 190 of 196

A.3 Power Spectral Density

§15.247(e)

Test Overview

Using the “Measure and Sum” technique, the measured conducted power density values were summed in linear power units then converted back to dBm. Original measured values are found in Section 7.4 of this report.

Frequency [MHz]	Channel No.	802.11 Mode	Data Rate [Mbps]	Measured Power Spectral Density [dBm]	Maximum Permissible Power Density [dBm / 3kHz]	Margin [dB]	Pass / Fail
2412	1	g	6	0.54	8.00	-7.46	Pass
2437	6	g	6	-0.92	8.00	-8.92	Pass
2462	11	g	6	-0.23	8.00	-8.23	Pass



Table A3-1. 802.11g Antenna-1 Conducted Power Density Measurements

Frequency [MHz]	Channel No.	802.11 Mode	Data Rate [Mbps]	Measured Power Spectral Density [dBm]	Maximum Permissible Power Density [dBm / 3kHz]	Margin [dB]	Pass / Fail
2412	1	g	6	-0.79	8.00	-8.79	Pass
2437	6	g	6	-0.18	8.00	-8.18	Pass
2462	11	g	6	-0.57	8.00	-8.57	Pass

Table A3-2. 802.11g Antenna-2 Conducted Power Density Measurements

Frequency [MHz]	Channel No.	802.11 Mode	Data Rate [Mbps]	Measured Power Spectral Density [dBm]	Maximum Permissible Power Density [dBm / 3kHz]	Margin [dB]	Pass / Fail
2412	1	g	6	-0.61	8.00	-8.61	Pass
2437	6	g	6	-0.30	8.00	-8.30	Pass
2462	11	g	6	-0.09	8.00	-8.09	Pass

Table A3-1. 802.11g Antenna-3 Conducted Power Density Measurements



FCC ID: A3LETWV531		FCC Pt. 15.247 802.11b/g/n/ac MEASUREMENT REPORT (CERTIFICATION)		Approved by: Quality Manager
Test Report S/N: 1M1705180171-02.A3L	Test Dates: 11/23/2016-02/17/2017	EUT Type: Indoor Access Point		Page 191 of 196

Frequency [MHz]	Channel No.	802.11 Mode	Data Rate [Mbps]	Measured Power Spectral Density [dBm]	Maximum Permissible Power Density [dBm / 3kHz]	Margin [dB]	Pass / Fail
2412	1	g	6	-0.14	8.00	-8.14	Pass
2437	6	g	6	-0.53	8.00	-8.53	Pass
2462	11	g	6	-0.78	8.00	-8.78	Pass

Table A3-2. 802.11g Antenna-4 Conducted Power Density Measurements

Frequency [MHz]	Channel No.	802.11 Mode	Data Rate [Mbps]	Directional Gain [dBi]	ANT 1 Power Spectral Density [dBm]	ANT 2 Power Spectral Density [dBm]	ANT 3 Power Spectral Density [dBm]	ANT 4 Power Spectral Density [dBm]	Summed MIMO Power Spectral Density [dBm]	Maximum Permissible Power Density [dBm / 3kHz]	Adjusted Limit	Margin [dB]	Pass / Fail
2412	1	g	6.5/7.2 (MCS0)	7.83	0.54	-0.79	-0.61	-0.14	5.80	8.00	6.17	-0.37	Pass
2437	6	g	6.5/7.2 (MCS0)	7.68	-0.92	-0.18	-0.30	-0.53	5.55	8.00	6.32	-0.77	Pass
2462	11	g	6.5/7.2 (MCS0)	7.32	-0.23	-0.57	-0.09	-0.78	5.61	8.00	6.68	-1.07	Pass

Table A3-3.802.11g Dual Tx Conducted Power Density Measurements

FCC ID: A3LETWV531		FCC Pt. 15.247 802.11b/g/n/ac MEASUREMENT REPORT (CERTIFICATION)		Approved by: Quality Manager
Test Report S/N: 1M1705180171-02.A3L	Test Dates: 11/23/2016-02/17/2017	EUT Type: Indoor Access Point		Page 192 of 196

A.4 Dual Tx Radiated Restricted Band Edge Measurements

§15.205 §15.209

The radiated restricted band edge measurements are measured with an EMI test receiver connected to the receive antenna while the EUT is transmitting on both outputs in 802.11g mode.

Worst Case Mode: 802.11g

Worst Case Transfer Rate: 6Mbps

Distance of Measurements: 3 Meters

Operating Frequency: 2412MHz

Channel: 1

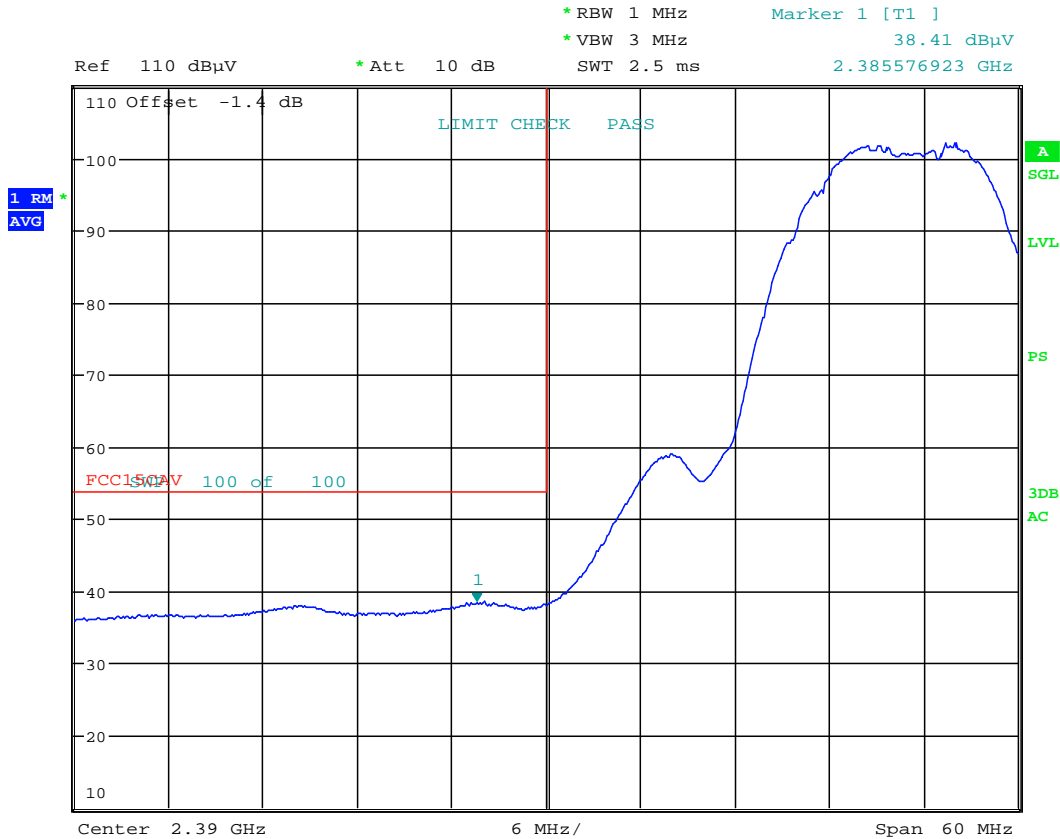

Date: 17.JAN.2017 08:24:57

Plot A4-1. Radiated Restricted Lower Band Edge Measurement (Average)

FCC ID: A3LETWV531		FCC Pt. 15.247 802.11b/g/n/ac MEASUREMENT REPORT (CERTIFICATION)		Approved by: Quality Manager
Test Report S/N: 1M1705180171-02.A3L	Test Dates: 11/23/2016-02/17/2017	EUT Type: Indoor Access Point		Page 193 of 196

Dual Tx Radiated Restricted Band Edge Measurements

§15.205 §15.209

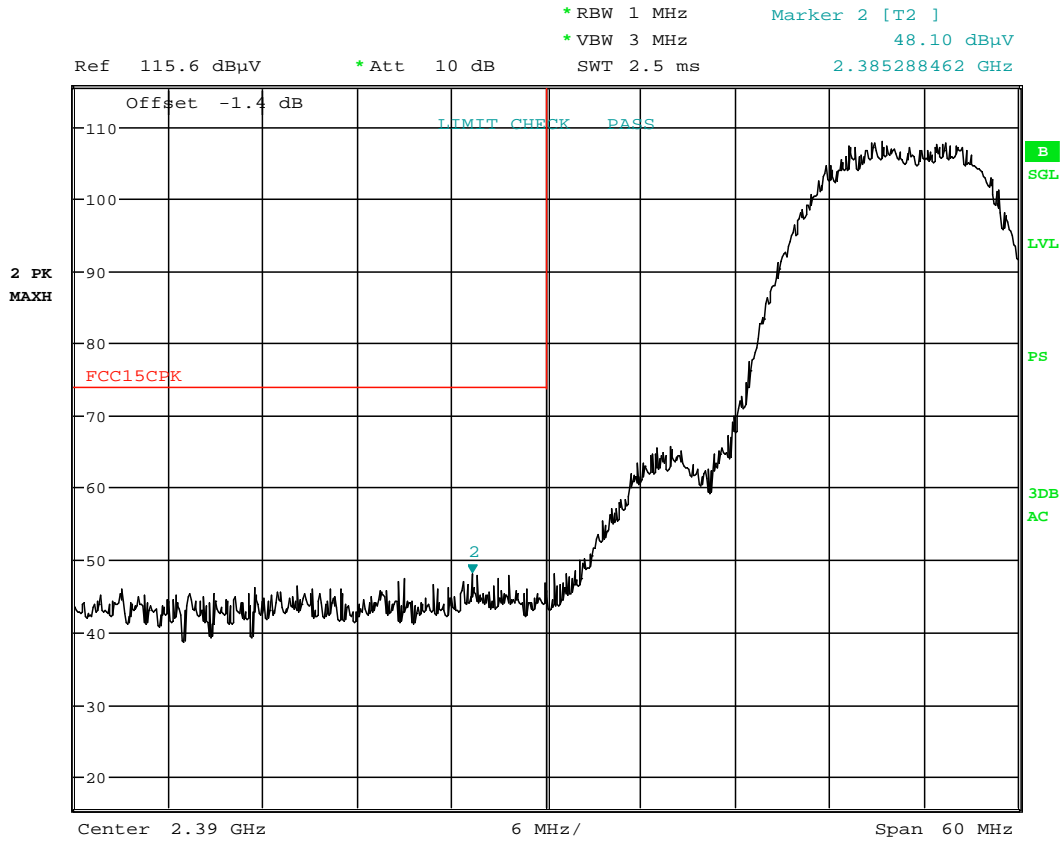

Date: 17.JAN.2017 08:25:32

Plot A4-2. Radiated Restricted Lower Band Edge Measurement (Peak)

FCC ID: A3LETWV531		FCC Pt. 15.247 802.11b/g/n/ac MEASUREMENT REPORT (CERTIFICATION)		Approved by: Quality Manager
Test Report S/N: 1M1705180171-02.A3L	Test Dates: 11/23/2016-02/17/2017	EUT Type: Indoor Access Point		Page 194 of 196

Dual Tx Radiated Restricted Band Edge Measurements

§15.205 §15.209

Worst Case Mode: 802.11g
 Worst Case Transfer Rate: 6Mbps
 Distance of Measurements: 3 Meters
 Operating Frequency: 2462MHz
 Channel: 11

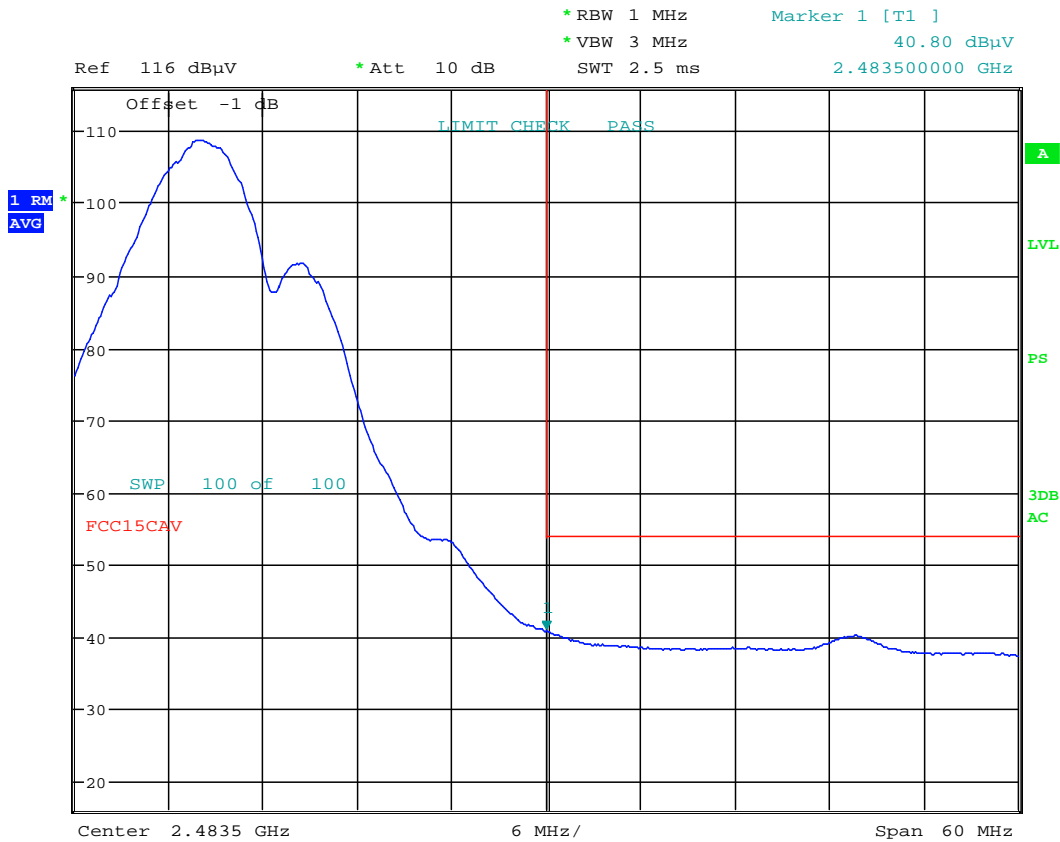

Date: 17.JAN.2017 08:36:15

Plot A4-3. Radiated Restricted Upper Band Edge Measurement (Average)

FCC ID: A3LETWV531		FCC Pt. 15.247 802.11b/g/n/ac MEASUREMENT REPORT (CERTIFICATION)		Approved by: Quality Manager
Test Report S/N: 1M1705180171-02.A3L	Test Dates: 11/23/2016-02/17/2017	EUT Type: Indoor Access Point		Page 195 of 196

Dual Tx Radiated Restricted Band Edge Measurements

§15.205 §15.209

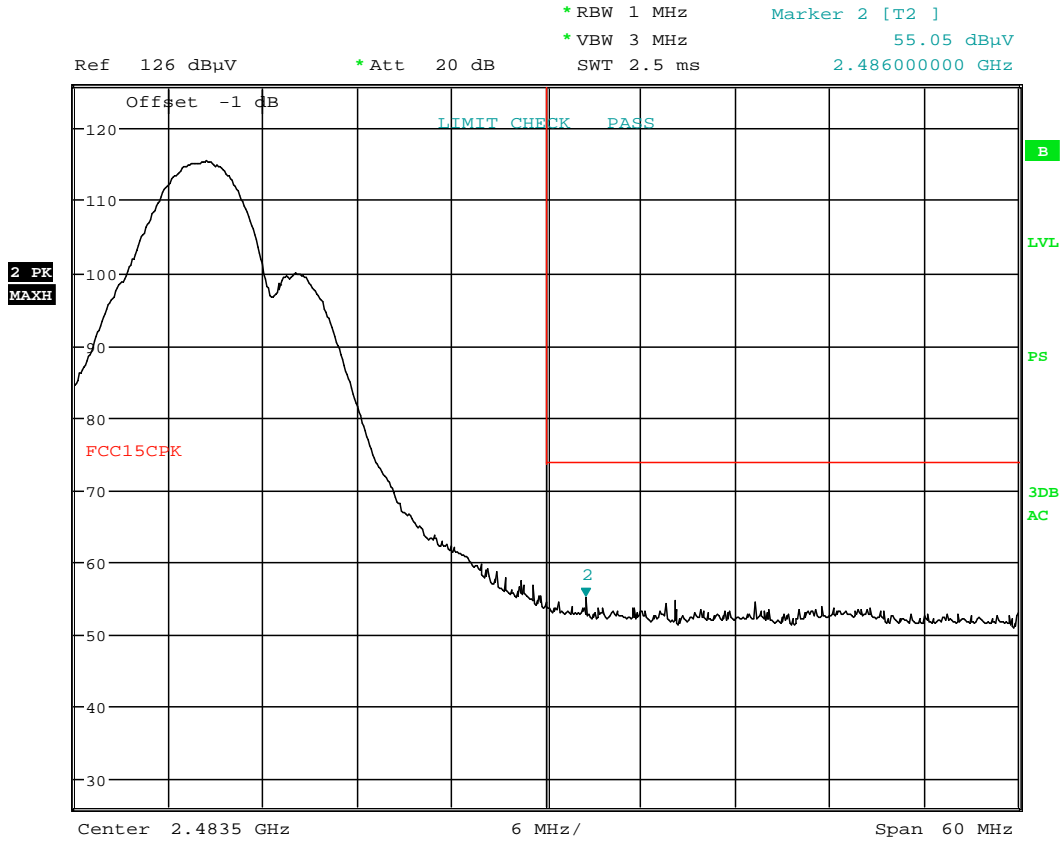

Date: 17.JAN.2017 08:37:03

Plot A4-4. Radiated Restricted Upper Band Edge Measurement (Peak)

FCC ID: A3LETWV531		FCC Pt. 15.247 802.11b/g/n/ac MEASUREMENT REPORT (CERTIFICATION)		Approved by: Quality Manager
Test Report S/N: 1M1705180171-02.A3L	Test Dates: 11/23/2016-02/17/2017	EUT Type: Indoor Access Point		Page 196 of 196