

TEST REPORT

of

FCC Part 15 Subpart C §15.209

FCC ID: A3LEPP6300

1. Equipment Under Test : WIRELESS CHARGER
2. Model Name : EP-P6300
3. Variant Model Name(s) : -
4. Applicant : Samsung Electronics Co., Ltd.
5. Manufacturer : Samsung Electronics Co., Ltd.
6. Date of Receipt : 2020.08.27
7. Date of Test(s) : 2020.09.01 ~ 2020.09.25
8. Date of Issue : 2020.09.25

In the configuration tested, the EUT complied with the standards specified above. This test report does not assure KOLAS accreditation.

- 1) The results of this test report are effective only to the items tested.
- 2) The SGS Korea is not responsible for the sampling, the results of this test report apply to the sample as received.

Tested by:

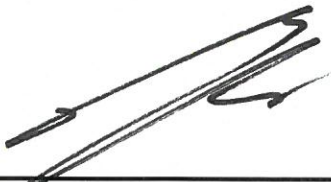

Murphy Kim

Technical
Manager:



Jungmin Yang

SGS Korea Co., Ltd. Gunpo Laboratory



SGS Korea Co., Ltd.

4, LS-ro 182beon-gil, Gunpo-si, Gyeonggi-do, Korea, 15807

Tel. +82 31 428 5700 / Fax. +82 31 427 2370

<http://www.sgsgroup.kr>

INDEX

Table of Contents

1. General Information	3
2. Field Strength of Fundamental and Spurious Emission	7
3. 20 dB Bandwidth	96
4. AC Power Line Conducted Emission	118

1. General Information

1.1. Testing Laboratory

- SGS Korea Co., Ltd. (Gunpo Laboratory)
- 10-2, LS-ro 182beon-gil, Gunpo-si, Gyeonggi-do, Korea, 15807
 - 4, LS-ro 182beon-gil, Gunpo-si, Gyeonggi-do, Korea, 15807
 - Designation number: KR0150

All SGS services are rendered in accordance with the applicable SGS conditions of service available on request and accessible at <http://www.sgs.com/en/Terms-and-Conditions.aspx>.

Phone No. : +82 31 688 0901
 Fax No. : +82 31 688 0921

1.2. Details of Applicant

Applicant : Samsung Electronics Co., Ltd.
 Address : 19 Chapin Rd., Building D, Pine Brook, New Jersey, United States, 07058
 Contact Person : Chun, Jenni
 Phone No. : +1 973 808 6362

1.3. Details of Manufacturer

Company : Samsung Electronics Co., Ltd.
 Address : Yen Phong 1 Industrial park, Yen Phong District Bac Ninh Province, VIETNAM

1.4. Description of EUT

Kind of Product	WIRELESS CHARGER	
Model Name	EP-P6300	
Power Supply	DC 9.0 V	
Operation Mode	2 W, 4.5 W, 7.5 W, 9W	
Frequency Range	119 kHz ~ 122 kHz	Ant.1, Ant. 2, Ant. 3, Ant. 4, Ant. 5, Ant. 6
	126.2 kHz ~ 129.2 kHz	Ant.1, Ant. 2, Ant. 3, Ant. 4, Ant. 5, Ant. 6
	136.5 kHz ~ 139.5 kHz	Ant.1, Ant. 2, Ant. 3
	144.5 kHz ~ 147.5 kHz	Ant. 4, Ant. 5, Ant. 6, Ant. 7
Antenna Type	Loop Coil Antenna	

1.5. Declaration by the Manufacturer

- The EUT has 7 loop coil antennas.
- 6 coils for 2 pairs of devices, 1 independent coil for smart watch.
- Product is designed to operate only 3 coils at a time and can charge maximum 3 devices simultaneously.

1.6. Test Equipment List

Equipment	Manufacturer	Model	S/N	Cal. Date	Cal. Interval	Cal. Due
Spectrum Analyzer	R&S	FSV30	103210	Dec. 05, 2019	Annual	Dec. 05, 2020
Signal Generator	R&S	SMBV100A	255834	Jun. 03, 2020	Annual	Jun. 03, 2021
Amplifier	H.P.	8447F	2944A03909	Aug. 06, 2020	Annual	Aug. 06, 2021
Loop Antenna	Schwarzbeck Mess-Elektronik	FMZB 1519	1519-039	Aug. 22, 2019	Biennial	Aug. 22, 2021
Bilog Antenna	Schwarzbeck Mess-Elektronik	VULB9163	396	Mar. 21, 2019	Biennial	Mar. 21, 2021
Test Receiver	R&S	ESU26	100109	Feb. 18, 2020	Annual	Feb. 18, 2021
Turn Table	Innco systems GmbH	DS 1200 S	N/A	N.C.R.	N/A	N.C.R.
Controller	Innco systems GmbH	CONTROLLER CO3000-4P	CO3000/963/38 330516/L	N.C.R.	N/A	N.C.R.
Anechoic Chamber	SY Corporation	L x W x H (9.6 m x 6.4 m x 6.6 m)	N/A	N.C.R.	N/A	N.C.R.
Coaxial Cable	RFONE	SFX086-NMNM-5M (5 m)	20200323001	Aug. 10, 2020	Semi-Annual	Feb. 10, 2021
Coaxial Cable	RFONE	PL520-NMNM-10M (10 m)	20200324001	Aug. 10, 2020	Semi-Annual	Feb. 10, 2021
Test Receiver	R&S	ESCI 7	100911	Feb. 19, 2020	Annual	Feb. 19, 2021
Two-Line V-Network	R&S	ENV216	100190	May 08, 2020	Annual	May 08, 2021
Shield Room	SY Corporation	L x W x H (6.5 m x 3.5 m x 3.5 m)	N/A	N.C.R.	N/A	N.C.R.

► Support Equipment

Description	Manufacturer	Model	FCC ID
Samsung Mobile Phone	Samsung Electronics Co., Ltd.	SM-G973U1	A3LSMG973U
Bluetooth Headset	Samsung Electronics Co., Ltd.	SM-R170	A3LSMR170L, A3LSMR170R
Smart Wearable Device	Samsung Electronics Co., Ltd.	SM-R500	A3LSMR500
C type USB Cable	Samsung Electronics Co., Ltd.	EP-DA705BBE, EP-DA705BWE	-
TRAVEL ADAPTER	DONGYANG E&P	EP-TA800	-

1.7. Sample Calculation

Where relevant, the following sample calculation is provided:

$$\text{Field strength level (dB}\mu\text{V/m)} = \text{Measured level (dB}\mu\text{V)} + \text{Antenna factor (dB)} + \text{Cable loss (dB)} + (\text{AMP (dB)})$$

1.8. Worst Case of Test Configurations

Charging mode with client device	Mode								Description
	2 W		4.5 W		7.5W		9W		
	Ant 1 ~ 3	Ant 4 ~ 7	Ant 1 ~ 3	Ant 4 ~ 6	Ant 1 ~ 3	Ant 4 ~ 6	Ant 1 ~ 3	Ant 4 ~ 6	
Model: SM-G973U1 FCC ID: A3LSMG973U			119 kHz ~ 122 kHz	119 kHz ~ 122 kHz	126.2 kHz ~ 129.2 kHz	126.2 kHz ~ 129.2 kHz			1 % of battery 50 % of battery 99 % of battery
Model: SM-R170 FCC ID: A3LSMR170L, A3LSMR170R	136.5 kHz ~ 139.5 kHz	144.5 kHz ~ 147.5 kHz	126.2 kHz ~ 129.2 kHz	126.2 kHz ~ 129.2 kHz			136.5 kHz ~ 139.5 kHz	144.5 kHz ~ 147.5 kHz	
Model: SM-R500 FCC ID: A3LSMR500			136.5 kHz ~ 139.5 kHz	144.5 kHz ~ 147.5 kHz	136.5 kHz ~ 139.5 kHz	136.5 kHz ~ 139.5 kHz			

Note;

EUT was investigated with client device under normal charging condition as above then worst value was only reported.

1.9. Summary of Test Results

The EUT has been tested according to the following specifications:

APPLIED STANDARD: FCC Part 15 Subpart C		
Section	Test Item(s)	Result
15.209	Radiated Emission, Spurious Emission and Field Strength of Fundamental	Complied
2.1049	20 dB Bandwidth	Complied
15.207	AC Power Line Conducted Emission	Complied

Note;

Due to the frequency range of the device is less than 1 MHz, so we perform Middle frequency according to 15.31 requirement.

1.10. Measurement Uncertainty

Where relevant, the following measurement uncertainty levels have been estimated for tests performed on the apparatus:

Parameter	Uncertainty
20 dB Bandwidth	± 9.66 kHz
AC Conducted Emission	± 3.45 dB
Radiated Disturbance, 9 kHz to 30 MHz	± 3.59 dB
Radiated Disturbance, below 1 GHz	± 5.88 dB

Uncertainty figures are valid to a confidence level of 95 %.

1.11. Test Report Revision

Revision	Report Number	Date of Issue	Description
0	F690501-RF-RTL001207	2020.09.25	Initial

2. Field Strength of Fundamental and Spurious Emission

2.1. Test Setup

The diagram below shows the test setup that is utilized to make the measurements for emission from 9 MHz to 30 MHz.

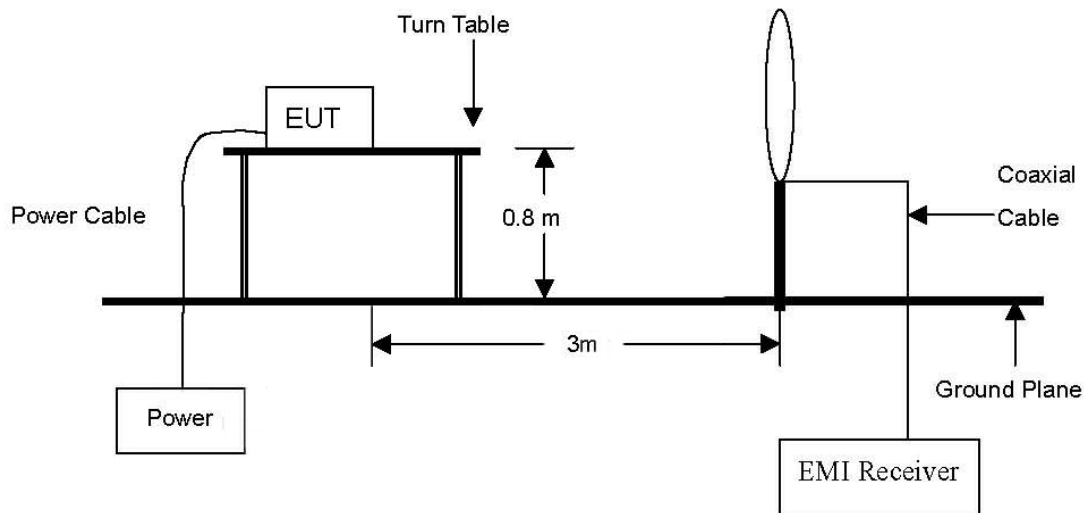

The diagram below shows the test setup that is utilized to make the measurements for emission from 30 MHz to 1 GHz.

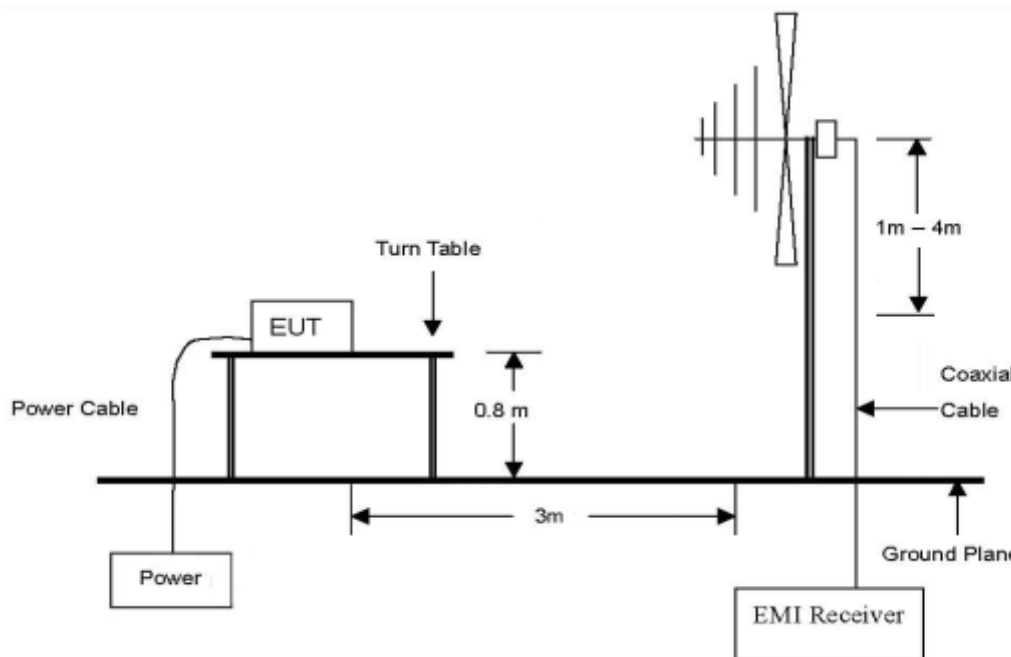

2.2. Limit

2.2.1. Radiated emission limits, general requirements

According to §15.209(a), except as provided elsewhere in this subpart, the emissions from an intentional radiator shall not exceed the field strength levels specified in the following table:

Frequency (MHz)	Field Strength (microvolts/meter)	Measurement Distance (meter)
0.009-0.490	2 400/F(kHz)	300
0.490-1.705	24 000/F(kHz)	30
1.705-30.0	30	30
30-88	100**	3
88-216	150**	3
216-960	200**	3
Above 960	500	3

** Except as provided in paragraph (g), fundamental emissions from intentional radiators operating under this section shall not be located in the frequency bands 54-72 MHz, 76-88 MHz, 174-216 MHz or 470-806 MHz. however, operation within these frequency bands is permitted under other sections of this part, e.g., §§15.231 and 15.241

2.3. Test Procedures

Radiated emissions from the EUT were measured according to the dictates of ANSI C63.10:2013.

2.3.1. Test Procedures for emission from 9 kHz to 30 MHz

- a. The EUT was placed on the top of a rotating table 0.8 meters above the ground at a 3 meter anechoic chamber test site. The table was rotated 360 degrees to determine the position of the highest radiation.
- b. Then antenna is a loop antenna is fixed at one meter above the ground to determine the maximum value of the field strength. Both parallel and perpendicular of the antenna are set to make the measurement.
- c. For each suspected emission, the EUT was arranged to its worst case and then the table was turned from 0 degrees to 360 degrees to find the maximum reading.
- d. The test-receiver system was set to Quasi Peak and Average Detect Function and Specified Bandwidth with Maximum Hold Mode.

2.3.2. Test Procedures for emission from 30 MHz to 1 000 MHz

- a. The EUT was placed on the top of a rotating table 0.8 meters above the ground at a 3 meter anechoic chamber test site. The table was rotated 360 degrees to determine the position of the highest radiation.
- b. During performing radiated emission below 1 GHz, the EUT was set 3 meters away from the interference receiving antenna, which was mounted on the top of a variable-height antenna tower. During performing radiated emission above 1 GHz, the EUT was set 3 meter away from the interference-receiving antenna.
- c. The antenna is a broadband antenna, and its height is varied from one meter to four meters above the ground to determine the maximum value of the field strength. Both horizontal and vertical polarizations of the antenna are set to make the measurement.
- d. For each suspected emission, the EUT was arranged to its worst case and then the antenna was tuned to heights from 1 meter to 4 meters and the table was turned from 0 degrees to 360 degrees to find the maximum reading.
- e. The test-receiver system was set to Peak Detect Function and Specified Bandwidth with Maximum Hold Mode.

2.4. Field Strength of Fundamental Test Result

Ambient temperature : (23 ± 1) °C
 Relative humidity : 47 % R.H.

The following table shows the highest levels of radiated emissions on between polarizations of horizontal and vertical.

Test Condition: 2 W Operating mode with client device (1 % battery status of client device)

Radiated Emissions			Ant.	Correction Factors		Total		Limit	
Frequency (MHz)	Reading (dB μ V)	Detect Mode	Pol.	AF (dB/m)	CL (dB)	Actual (dB μ V/m) at 3 m	Actual (dB μ V/m) at 300 m	Limit (dB μ V/m) at 300 m	Margin (dB)
Ant. 7 (144.5 kHz ~ 147.5 kHz)									
0.146	44.70	Average	H	17.80	0.06	62.56	-17.44	24.32	41.76

Test Condition: 4.5 W Operating mode with client device (1 % battery status of client device)

Radiated Emissions			Ant.	Correction Factors		Total		Limit	
Frequency (MHz)	Reading (dB μ V)	Detect Mode	Pol.	AF (dB/m)	CL (dB)	Actual (dB μ V/m) at 3 m	Actual (dB μ V/m) at 300 m	Limit (dB μ V/m) at 300 m	Margin (dB)
Ant. 1 (119 kHz ~ 122 kHz)									
0.120	71.92	Average	H	17.80	0.04	89.76	9.76	26.02	16.26
Ant. 1 (126.2 kHz ~ 129.2 kHz)									
0.126	71.70	Average	H	17.80	0.05	89.55	9.55	25.60	16.05
Ant. 6 (119 kHz ~ 122 kHz)									
0.122	71.90	Average	H	17.80	0.05	89.75	9.75	25.88	16.13
Ant. 6 (126.2 kHz ~ 129.2 kHz)									
0.129	70.90	Average	H	17.80	0.05	88.75	8.75	25.39	16.64

Test Condition: 9 W Operating mode with client device (1 % battery status of client device)

Radiated Emissions			Ant.	Correction Factors		Total		Limit	
Frequency (MHz)	Reading (dB μ V)	Detect Mode	Pol.	AF (dB/m)	CL (dB)	Actual (dB μ V/m) at 3 m	Actual (dB μ V/m) at 300 m	Limit (dB μ V/m) at 300 m	Margin (dB)
Ant. 1 (136.5 kHz ~ 139.5 kHz)									
0.138	72.10	Average	H	17.80	0.06	89.96	9.96	24.81	14.85
Ant. 6 (144.5 kHz ~ 147.5 kHz)									
0.146	72.10	Average	H	17.80	0.06	89.96	9.96	24.32	14.36

Test Condition: 2 W & 4.5W Operating mode with 3 client devices (1 % battery status of client device)

Radiated Emissions			Ant.	Correction Factors		Total		Limit	
Frequency (MHz)	Reading (dB μ V)	Detect Mode	Pol.	AF (dB/m)	CL (dB)	Actual (dB μ V/m) at 3 m	Actual (dB μ V/m) at 300 m	Limit (dB μ V/m) at 300 m	Margin (dB)
Ant. 1 (119 kHz ~ 122 kHz) & Ant. 6 (119 kHz ~ 122 kHz) & Ant. 7 (144.5 kHz ~ 147.5 kHz)									
0.120	70.30	Average	H	17.80	0.04	88.14	8.14	26.02	17.88
0.122	70.40	Average	H	17.80	0.05	88.25	8.25	25.88	17.63
0.147	44.30	Average	H	17.80	0.06	62.16	-17.84	24.26	42.10
Ant. 1 (119 kHz ~ 122 kHz) & Ant. 6 (126.2 kHz ~ 129.2 kHz) & Ant. 7 (144.5 kHz ~ 147.5 kHz)									
0.120	70.90	Average	H	17.80	0.04	88.74	8.74	26.02	17.28
0.129	69.82	Average	H	17.80	0.05	87.67	7.67	25.39	17.72
0.147	48.10	Average	H	17.80	0.06	65.96	-14.04	24.26	38.30
Ant. 1 (126.2 kHz ~ 129.2 kHz) & Ant. 6 (119 kHz ~ 122 kHz) & Ant. 7 (144.5 kHz ~ 147.5 kHz)									
0.122	69.70	Average	H	17.80	0.05	87.55	7.55	25.88	18.33
0.126	69.20	Average	H	17.80	0.05	87.05	7.05	25.60	18.55
0.146	44.80	Average	H	17.80	0.06	62.66	-17.34	24.32	41.66
Ant. 1 (126.2 kHz ~ 129.2 kHz) & Ant. 6 (126.2 kHz ~ 129.2 kHz) & Ant. 7 (144.5 kHz ~ 147.5 kHz)									
0.126	70.23	Average	H	17.80	0.05	88.08	8.08	25.60	17.52
0.129	69.70	Average	H	17.80	0.05	87.55	7.55	25.39	17.84
0.146	44.00	Average	H	17.80	0.06	61.86	-18.14	24.32	42.46

Test Condition: 2 W & 7.5W Operating mode with 3 client devices (1 % battery status of client device)

Radiated Emissions			Ant.	Correction Factors		Total		Limit	
Frequency (MHz)	Reading (dB μ V)	Detect Mode	Pol.	AF (dB/m)	CL (dB)	Actual (dB μ V/m) at 3 m	Actual (dB μ V/m) at 300 m	Limit (dB μ V/m) at 300 m	Margin (dB)
Ant. 1 (136.5 kHz ~ 139.5 kHz) & Ant. 6 (144.5 kHz ~ 147.5 kHz) & Ant. 7 (144.5 kHz ~ 147.5 kHz)									
0.138	69.90	Average	H	17.80	0.06	87.76	7.76	24.81	17.05
0.146	68.90	Average	H	17.80	0.06	86.76	6.76	24.32	17.56
0.147	46.10	Average	H	17.80	0.06	63.96	-16.04	24.26	40.30
Ant. 1 (136.5 kHz ~ 139.5 kHz) & Ant. 6 (126.2 kHz ~ 129.2 kHz) & Ant. 7 (144.5 kHz ~ 147.5 kHz)									
0.129	69.20	Average	H	17.80	0.05	87.05	7.05	25.39	18.34
0.138	70.20	Average	H	17.80	0.06	88.06	8.06	24.81	16.75
0.147	43.20	Average	H	17.80	0.06	61.06	-18.94	24.26	43.20
Ant. 1 (126.2 kHz ~ 129.2 kHz) & Ant. 6 (144.5 kHz ~ 147.5 kHz) & Ant. 7 (144.5 kHz ~ 147.5 kHz)									
0.126	69.53	Average	H	17.80	0.05	87.38	7.38	25.60	18.22
0.146	68.50	Average	H	17.80	0.06	86.36	6.36	24.32	17.96
0.147	41.70	Average	H	17.80	0.06	59.56	-20.44	24.26	44.70
Ant. 1 (126.2 kHz ~ 129.2 kHz) & Ant. 6 (126.2 kHz ~ 129.2 kHz) & Ant. 7 (144.5 kHz ~ 147.5 kHz)									
0.126	70.00	Average	H	17.80	0.05	87.85	7.85	25.60	17.75
0.129	68.60	Average	H	17.80	0.05	86.45	6.45	25.39	18.94
0.146	43.10	Average	H	17.80	0.06	60.96	-19.04	24.32	43.36

Test Condition: 2 W & 9W Operating mode with 3 client devices (1 % battery status of client device)

Radiated Emissions			Ant.	Correction Factors		Total		Limit	
Frequency (MHz)	Reading (dB μ V)	Detect Mode	Pol.	AF (dB/m)	CL (dB)	Actual (dB μ V/m) at 3 m	Actual (dB μ V/m) at 300 m	Limit (dB μ V/m) at 300 m	Margin (dB)
Ant. 1 (136.5 kHz ~ 139.5 kHz) & Ant. 6 (144.5 kHz ~ 147.5 kHz) & Ant. 7 (144.5 kHz ~ 147.5 kHz)									
0.138	71.70	Average	H	17.80	0.06	89.56	9.56	24.81	15.25
0.146	71.91	Average	H	17.80	0.06	89.77	9.77	24.32	14.55
0.147	46.70	Average	H	17.80	0.06	64.56	-15.44	24.26	39.70

Test Condition: 2 W & 4.5W & 9W Operating mode with 3 client devices (1 % battery status of client device)

Radiated Emissions			Ant.	Correction Factors		Total		Limit	
Frequency (MHz)	Reading (dB μ V)	Detect Mode	Pol.	AF (dB/m)	CL (dB)	Actual (dB μ V/m) at 3 m	Actual (dB μ V/m) at 300 m	Limit (dB μ V/m) at 300 m	Margin (dB)
Ant. 1 (136.5 kHz ~ 139.5 kHz) & Ant. 6 (119 kHz ~ 122 kHz) & Ant. 7 (144.5 kHz ~ 147.5 kHz)									
0.122	69.00	Average	H	17.80	0.05	86.85	6.85	25.88	19.03
0.138	70.60	Average	H	17.80	0.06	88.46	8.46	24.81	16.35
0.146	43.90	Average	H	17.80	0.06	61.76	-18.24	24.32	42.56
Ant. 1 (136.5 kHz ~ 139.5 kHz) & Ant. 6 (126.2 kHz ~ 129.2 kHz) & Ant. 7 (144.5 kHz ~ 147.5 kHz)									
0.129	69.20	Average	H	17.80	0.05	87.05	7.05	25.39	18.34
0.138	70.93	Average	H	17.80	0.06	88.79	8.79	24.81	16.02
0.147	44.90	Average	H	17.80	0.06	62.76	-17.24	24.26	41.50
Ant. 1 (119 kHz ~ 122 kHz) & Ant. 6 (144.5 kHz ~ 147.5 kHz) & Ant. 7 (144.5 kHz ~ 147.5 kHz)									
0.120	70.10	Average	H	17.80	0.04	87.94	7.94	26.02	18.08
0.146	71.90	Average	H	17.80	0.06	89.76	9.76	24.32	14.56
0.147	36.10	Average	H	17.80	0.06	53.96	-26.04	24.26	50.30
Ant. 1 (126.2 kHz ~ 129.2 kHz) & Ant. 6 (144.5 kHz ~ 147.5 kHz) & Ant. 7 (144.5 kHz ~ 147.5 kHz)									
0.126	69.80	Average	H	17.80	0.05	87.65	7.65	25.60	17.95
0.146	71.70	Average	H	17.80	0.06	89.56	9.56	24.32	14.76
0.147	47.50	Average	H	17.80	0.06	65.36	-14.64	24.26	38.90

Test Condition: Ping mode with client device (Standby mode)

Radiated Emissions			Ant.	Correction Factors		Total		Limit	
Frequency (MHz)	Reading (dB μ V)	Detect Mode	Pol.	AF (dB/m)	CL (dB)	Actual (dB μ V/m) at 3 m	Actual (dB μ V/m) at 300 m	Limit (dB μ V/m) at 300 m	Margin (dB)
Ant. All (136.5 kHz ~ 139.5 kHz & 144.5 kHz ~ 147.5 kHz)									
0.138	71.90	Average	H	17.80	0.06	89.76	9.76	24.81	15.05
0.146	74.70	Average	H	17.80	0.06	92.56	12.56	24.32	11.76
0.147	48.60	Average	H	17.80	0.06	66.46	-13.54	24.26	37.80

Remark;

1. According to §15.31(f)(2),
 - 300 m Result (dB μ V/m) = 3 m Result (dB μ V/m) - 40log (300/3) (dB μ V/m).
2. According to field strength table of general requirement in §15.209(a), field strength limits below 1.705 MHz were calculated as below.
 - 9 kHz to 490 kHz: 20log (2 400 / F (kHz)) at 300 m (dB μ V/m)
 - 490 kHz to 1.705 MHz: 20log (24 000/F (kHz)) at 30 m (dB μ V/m)
3. According to §15.209(d), the measurements were tested by using Quasi peak detector except for the frequency bands 9-90 kHz, 110-490 kHz and above 1 GHz in these three bands on measurements employing an average detector.
4. The limit above was calculated based on table of §15.209(a).

- Test plots

Test Condition: 2 W Operating mode with client device (1 % battery status of client device)

Ant. 7 (144.5 kHz ~ 147.5 kHz)

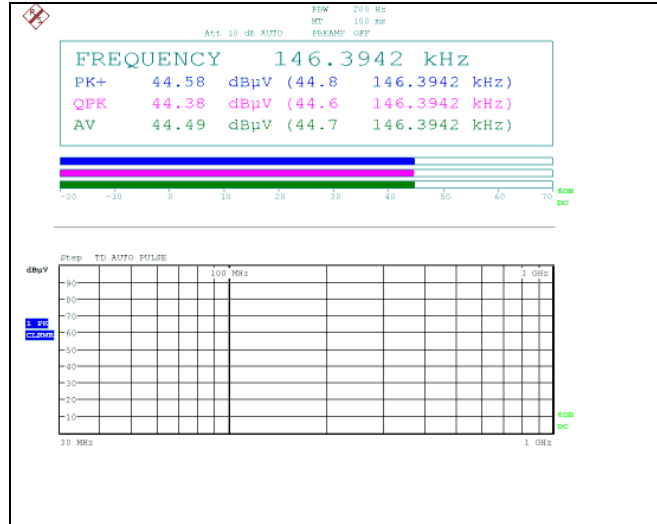

Test Condition: 4.5 W Operating mode with client device (1 % battery status of client device)

Ant. 1 (119 kHz ~ 122 kHz)

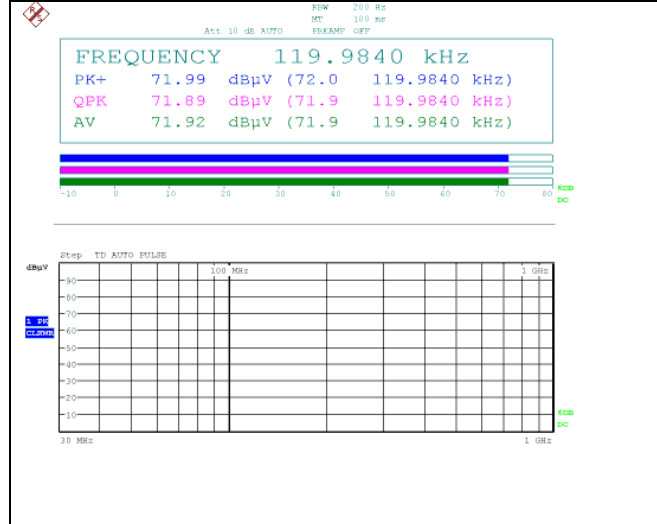

Ant. 1 (126.2 kHz ~ 129.2 kHz)

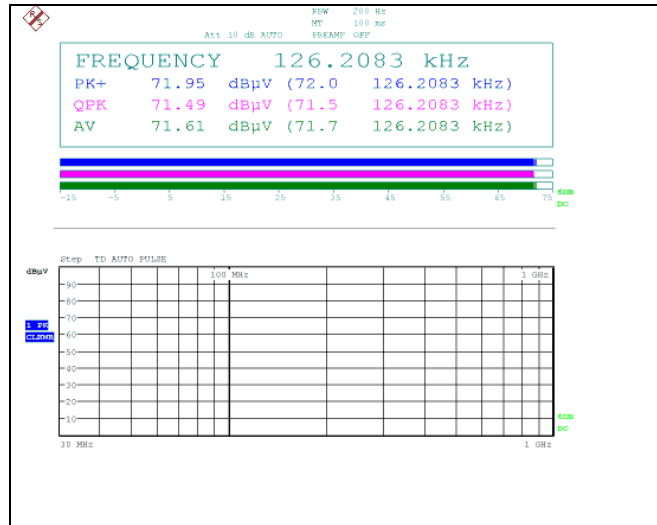

Ant. 6 (119 kHz ~ 122 kHz)

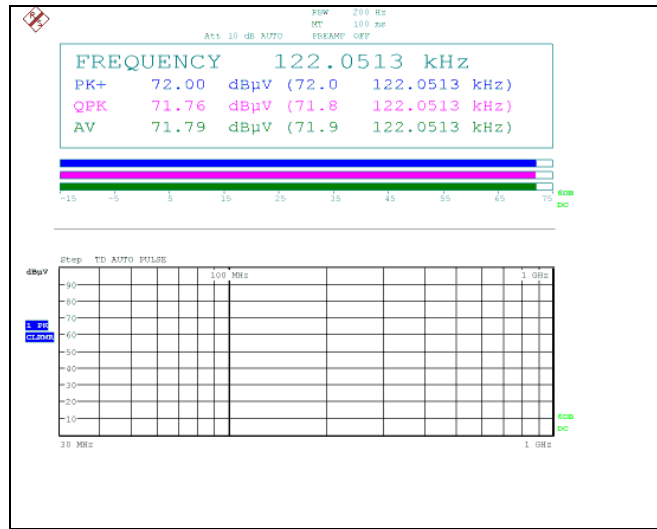

Ant. 6 (126.2 kHz ~ 129.2 kHz)

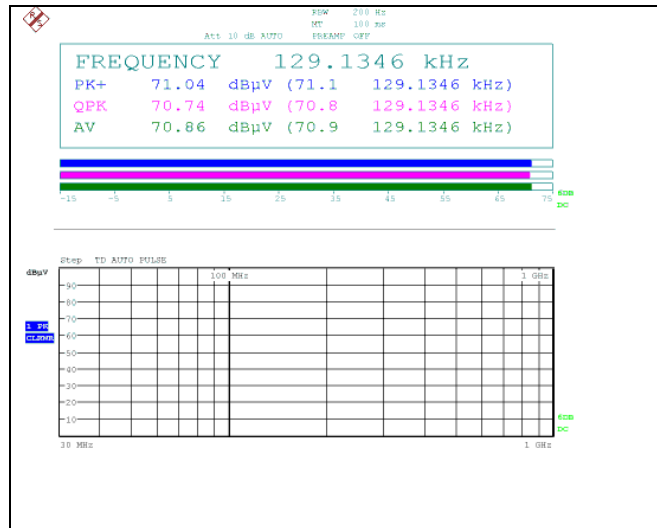

Test Condition: 9 W Operating mode with client device (1 % battery status of client device)

Ant. 1 (136.5 kHz ~ 139.5 kHz)

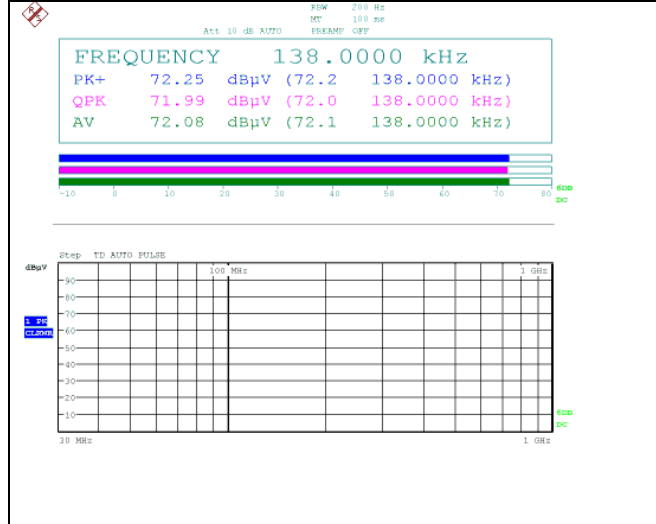

Ant. 6 (144.5 kHz ~ 147.5 kHz)

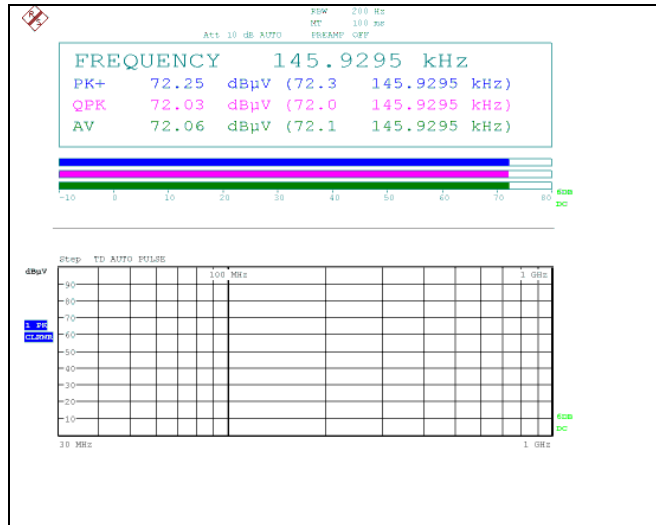

Test Condition: 2 W & 4.5W Operating mode with 3 client devices (1 % battery status of client device)

Ant. 1 (119 kHz ~ 122 kHz) & Ant. 6 (119 kHz ~ 122 kHz) & Ant. 7 (144.5 kHz ~ 147.5 kHz)

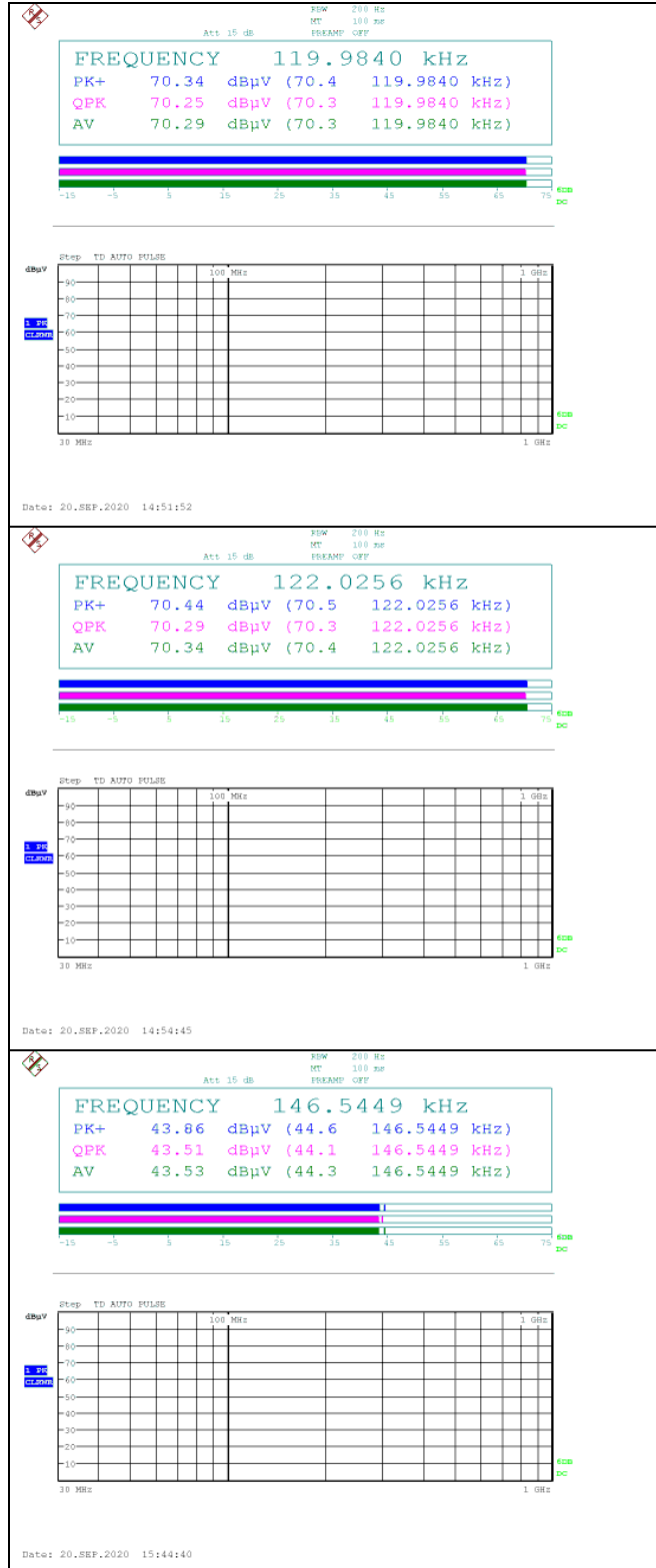

Ant. 1 (119 ㎐ ~ 122 ㎐) & Ant. 6 (126.2 ㎐ ~ 129.2 ㎐) & Ant. 7 (144.5 ㎐ ~ 147.5 ㎐)

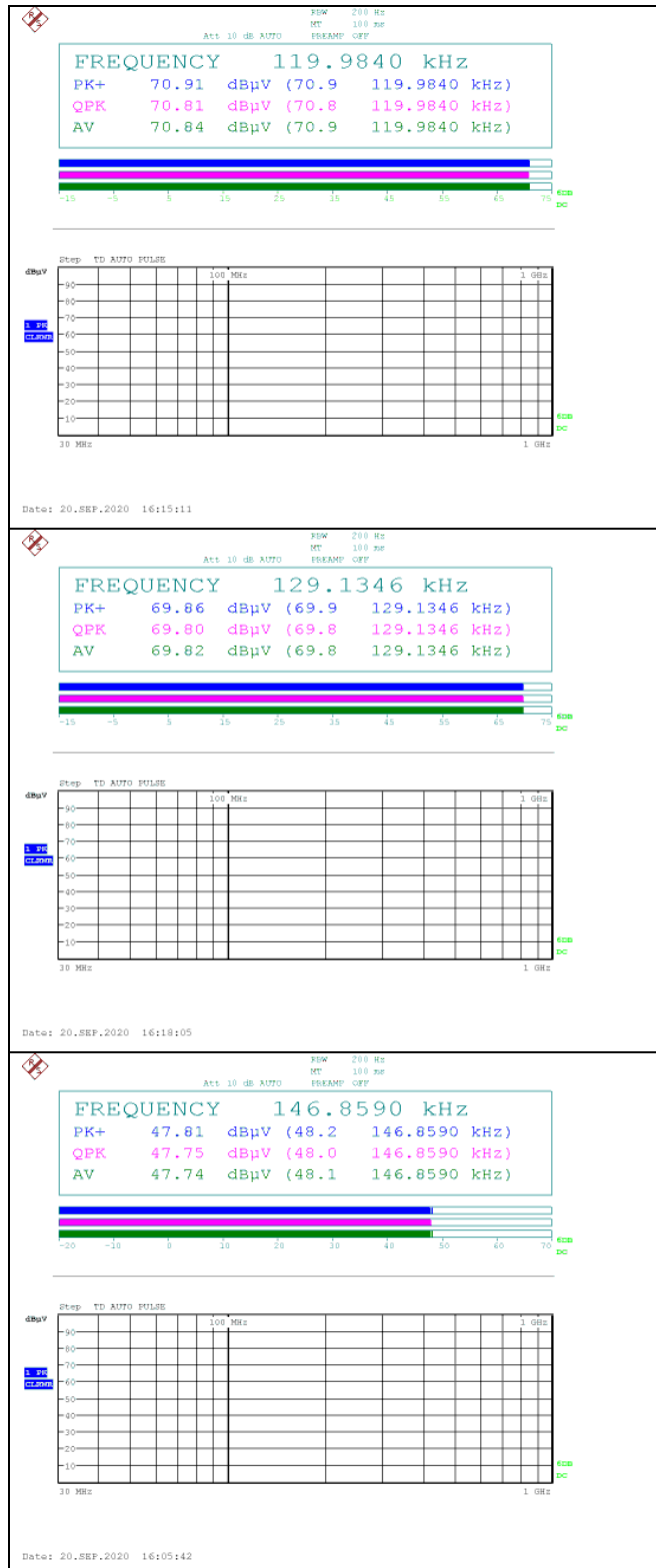

Ant. 1 (126.2 kHz ~ 129.2 kHz) & Ant. 6 (119 kHz ~ 122 kHz) & Ant. 7 (144.5 kHz ~ 147.5 kHz)

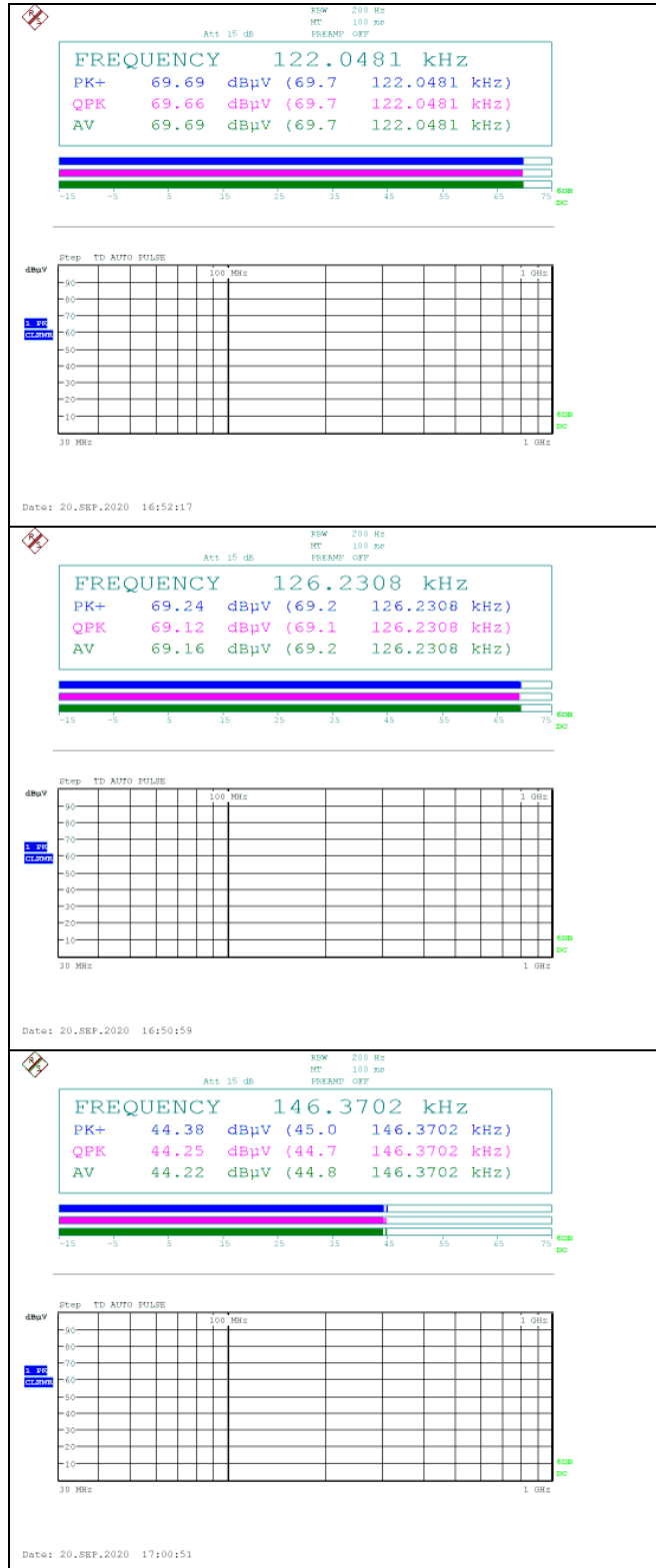

Ant. 1 (126.2 kHz ~ 129.2 kHz) & Ant. 6 (126.2 kHz ~ 129.2 kHz) & Ant. 7 (144.5 kHz ~ 147.5 kHz)

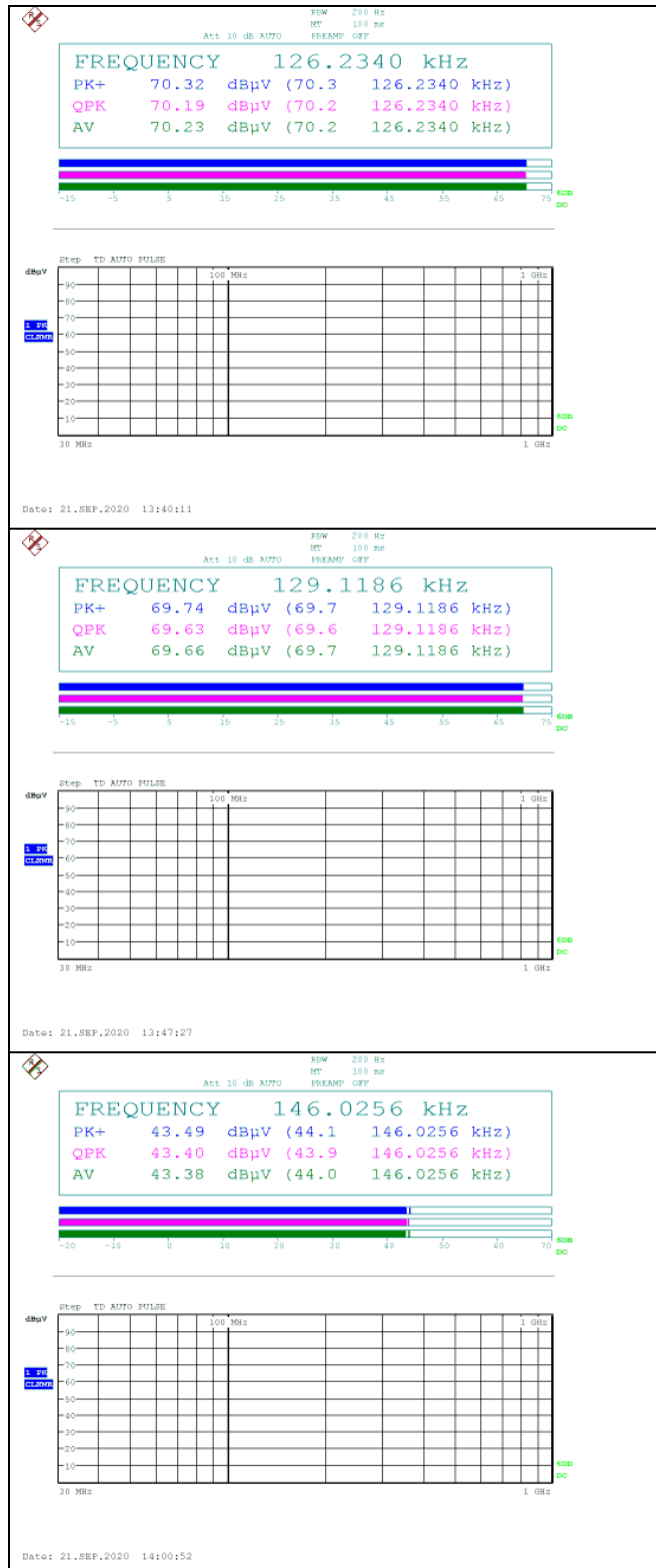

Test Condition: 2 W & 7.5W Operating mode with 3 client devices (1 % battery status of client device)

Ant. 1 (136.5 kHz ~ 139.5 kHz) & Ant. 6 (144.5 kHz ~ 147.5 kHz) & Ant. 7 (144.5 kHz ~ 147.5 kHz)

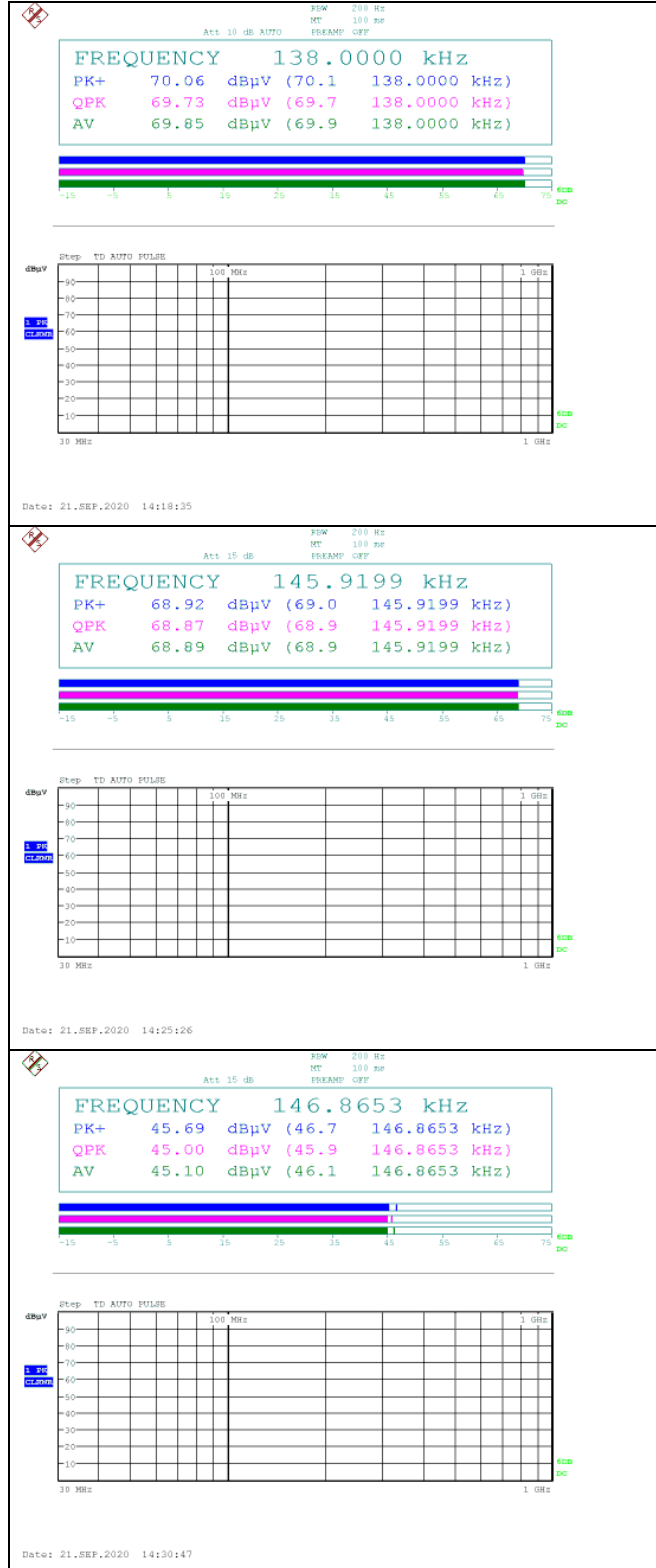

Ant. 1 (136.5 kHz ~ 139.5 kHz) & Ant. 6 (126.2 kHz ~ 129.2 kHz) & Ant. 7 (144.5 kHz ~ 147.5 kHz)

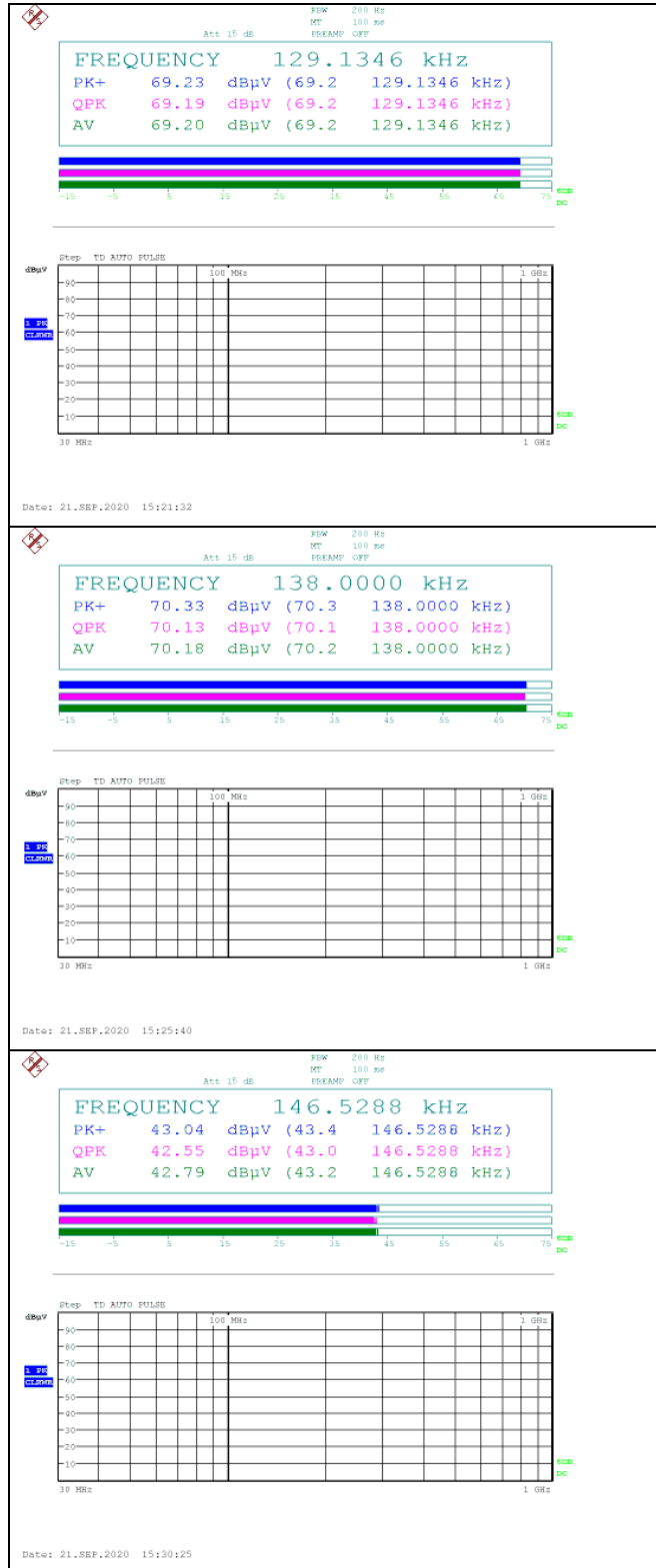

Ant. 1 (126.2 kHz ~ 129.2 kHz) & Ant. 6 (144.5 kHz ~ 147.5 kHz) & Ant. 7 (144.5 kHz ~ 147.5 kHz)

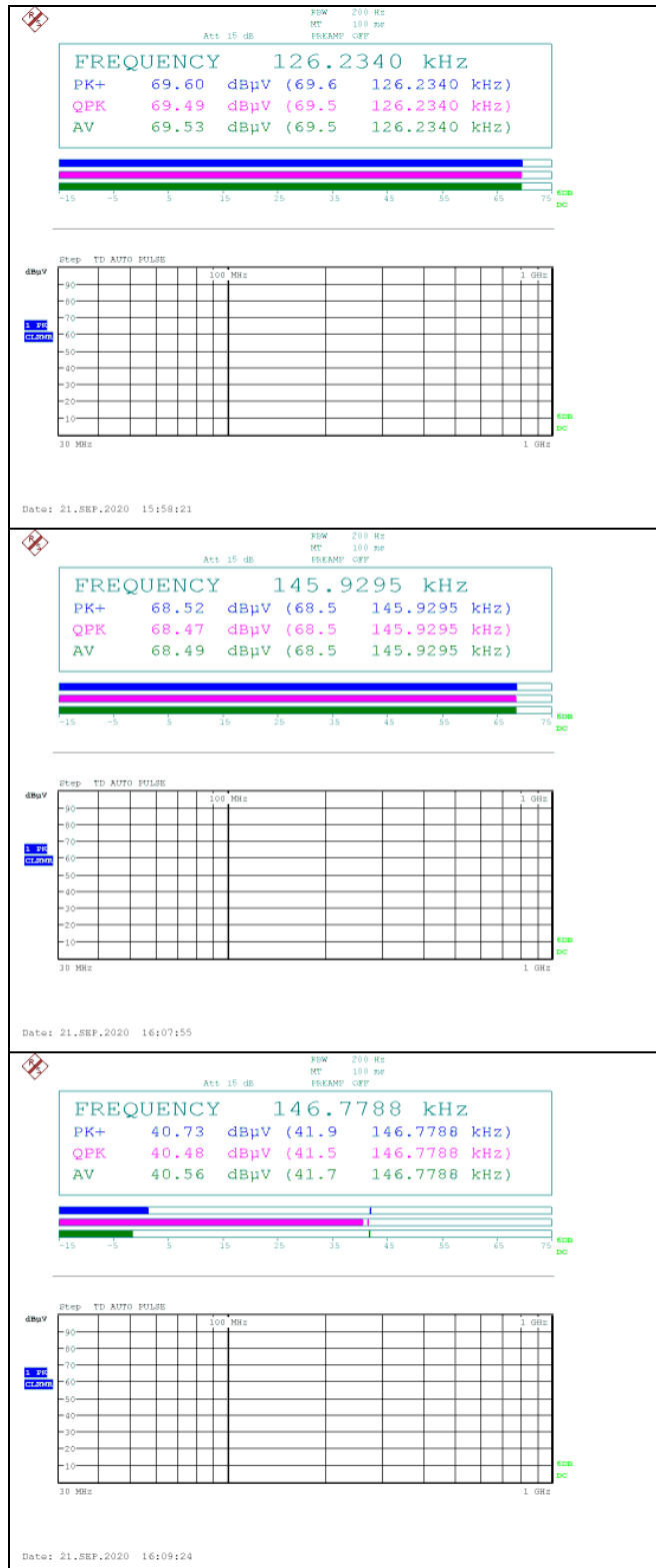

Ant. 1 (126.2 kHz ~ 129.2 kHz) & Ant. 6 (126.2 kHz ~ 129.2 kHz) & Ant. 7 (144.5 kHz ~ 147.5 kHz)

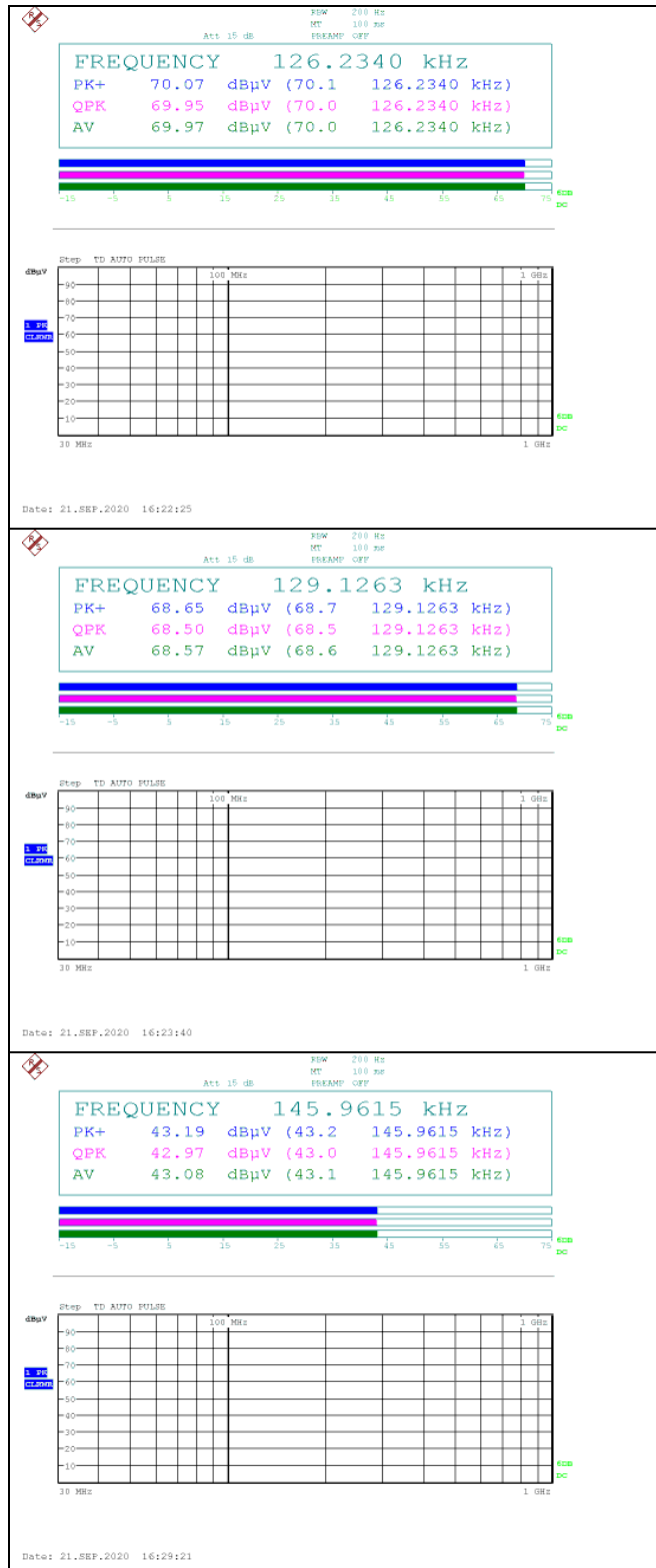

Test Condition: 2 W & 9W Operating mode with 3 client devices (1 % battery status of client device)

Ant. 1 (136.5 kHz ~ 139.5 kHz) & Ant. 6 (144.5 kHz ~ 147.5 kHz) & Ant. 7 (144.5 kHz ~ 147.5 kHz)

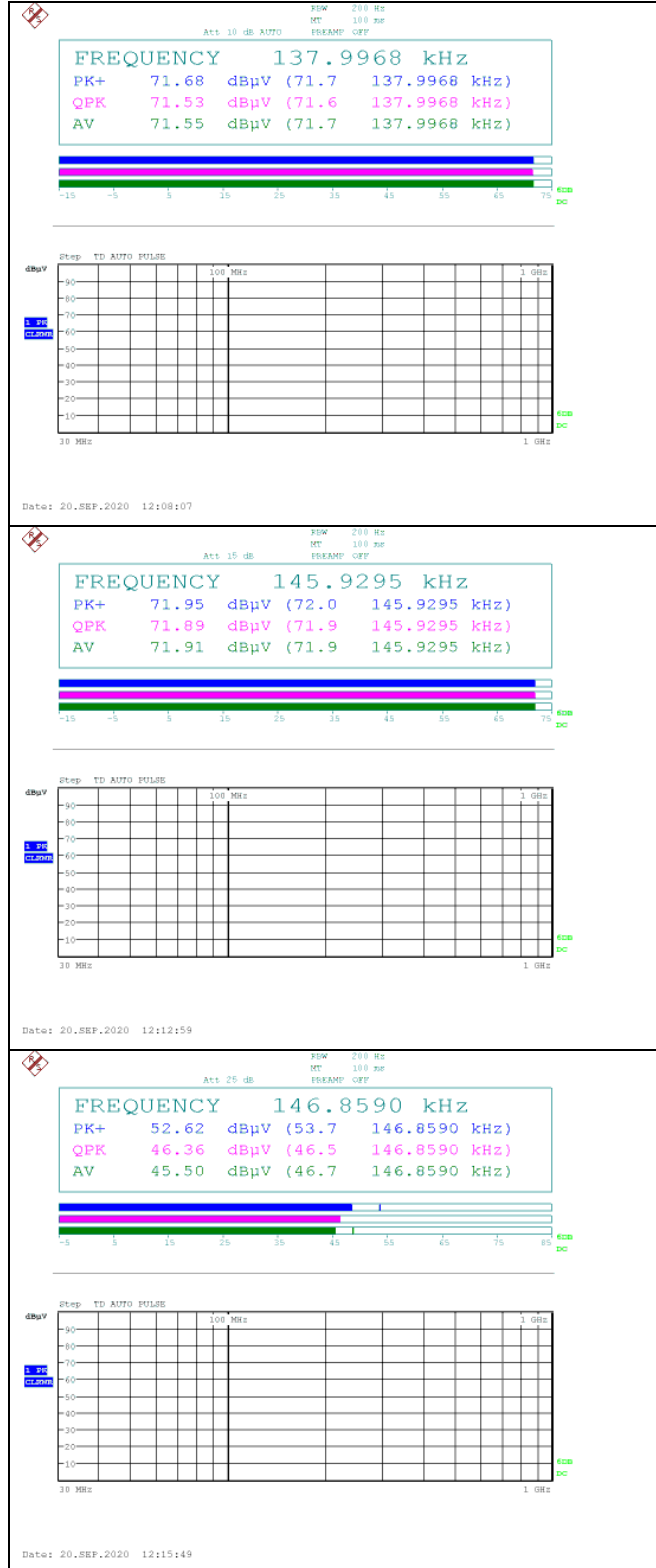

Test Condition: 2 W & 4.5W & 9W Operating mode with 3 client devices (1 % battery status of client device)

Ant. 1 (136.5 kHz ~ 139.5 kHz) & Ant. 6 (119 kHz ~ 122 kHz) & Ant. 7 (144.5 kHz ~ 147.5 kHz)

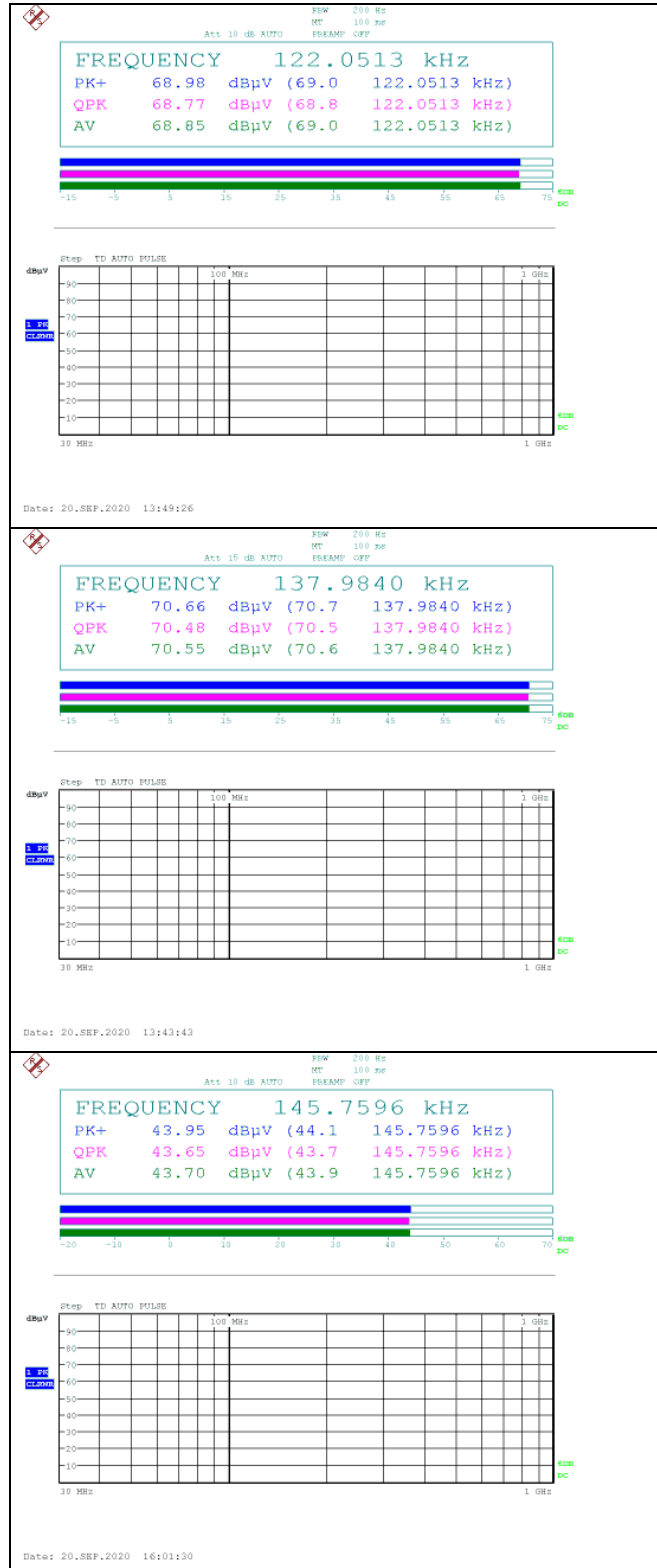

Ant. 1 (136.5 kHz ~ 139.5 kHz) & Ant. 6 (126.2 kHz ~ 129.2 kHz) & Ant. 7 (144.5 kHz ~ 147.5 kHz)

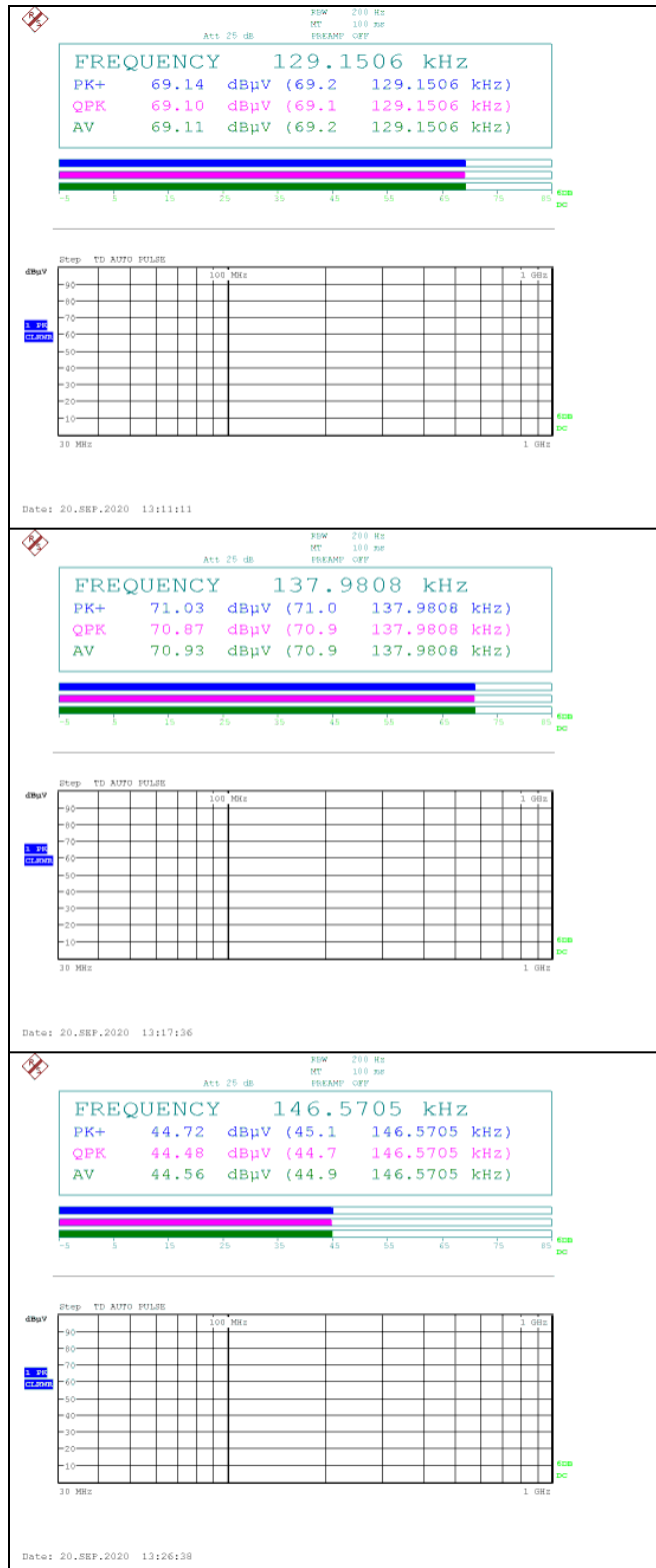

Ant. 1 (119 kHz ~ 122 kHz) & Ant. 6 (144.5 kHz ~ 147.5 kHz) & Ant. 7 (144.5 kHz ~ 147.5 kHz)

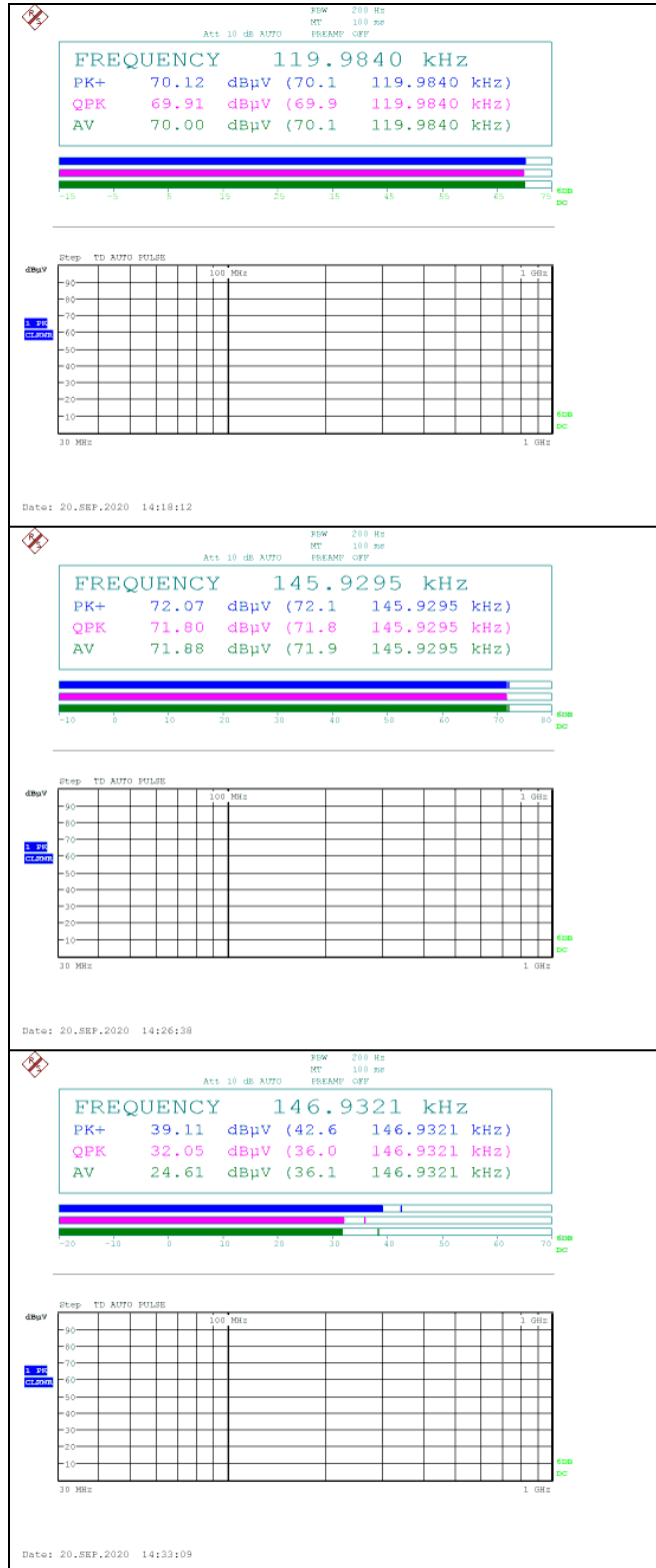

Ant. 1 (126.2 kHz ~ 129.2 kHz) & Ant. 6 (144.5 kHz ~ 147.5 kHz) & Ant. 7 (144.5 kHz ~ 147.5 kHz)

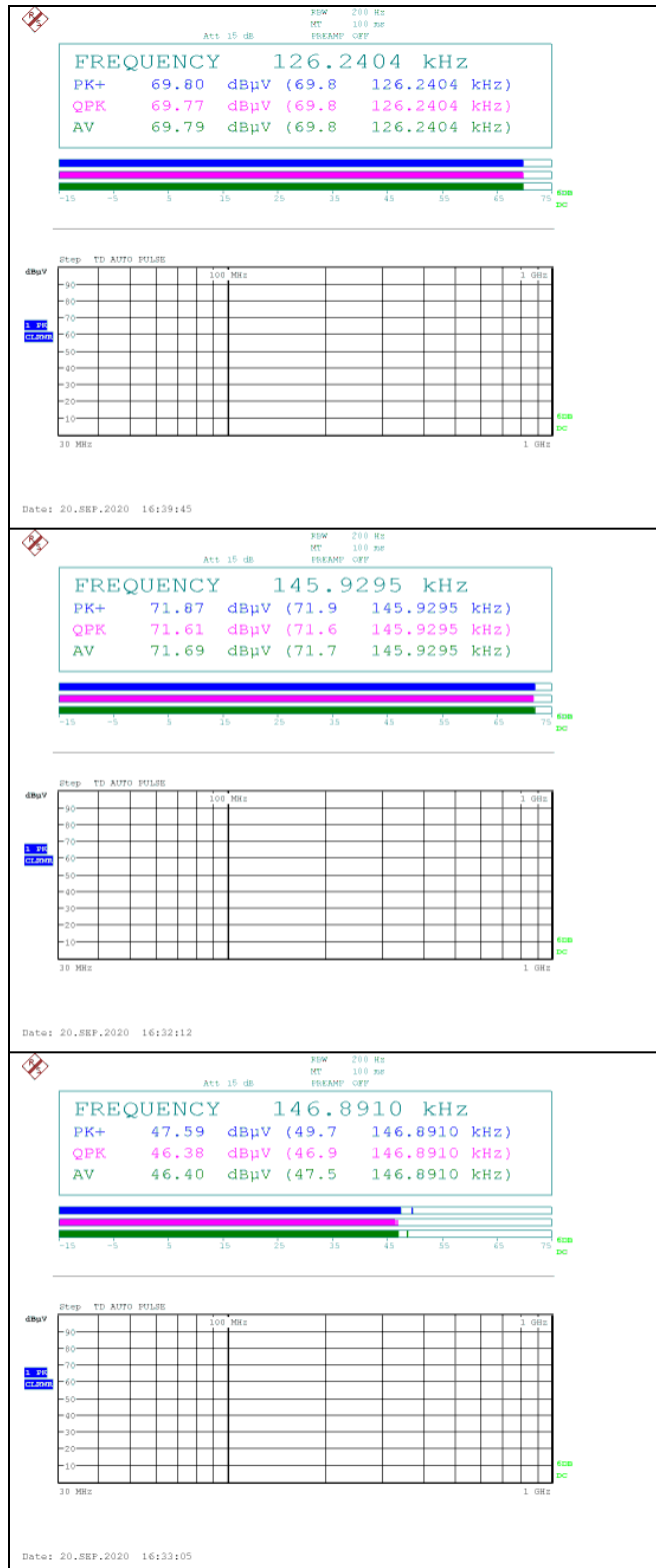

Test Condition: Ping mode with client device (Standby mode)

Ant. All (136.5 kHz ~ 139.5 kHz & 144.5 kHz ~ 147.5 kHz)

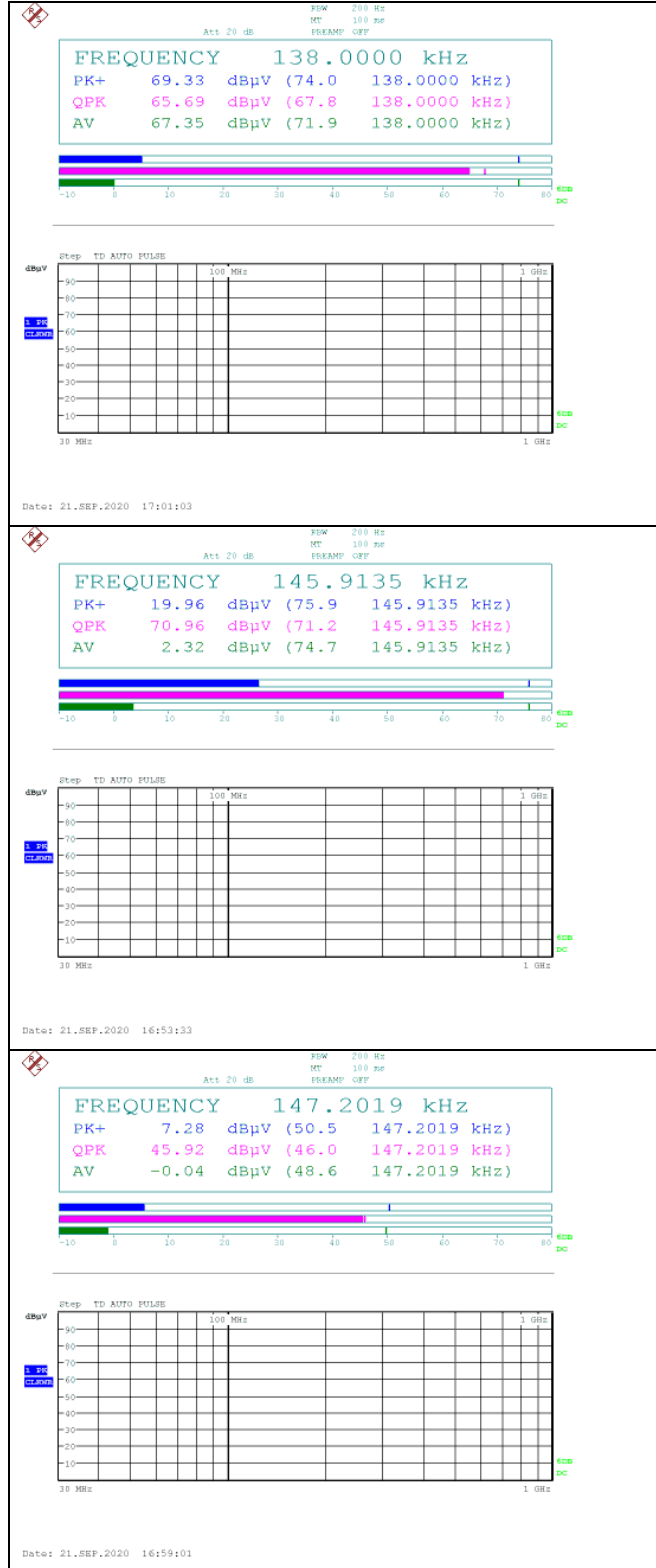

2.5. Spurious Emission Test Result

Ambient temperature : (23 ± 1) °C
 Relative humidity : 47 % R.H.

The following table shows the highest levels of radiated emissions on between polarizations of horizontal and vertical.

Test Condition: 2 W Operating mode with client device (1 % battery status of client device)

Ant. 7 (136.5 kHz ~ 139.5 kHz)

Below 30 MHz

Radiated Emissions			Ant.	Correction Factors		Total		Limit	
Frequency (MHz)	Reading (dBμV)	Detect Mode	Pol.	AF (dB/m)	CL (dB)	Actual (dBμV/m) at 3 m	Actual (dBμV/m) at 300 m or 30 m	Limit (dBμV/m) at 300 m or 30 m	Margin (dB)
0.021	31.00	Average	H	18.17	0.02	49.19	-30.81	41.16	71.97
0.036	39.40	Average	H	17.89	0.02	57.31	-22.69	36.48	59.17
0.044	21.90	Average	H	17.88	0.02	39.80	-40.20	34.74	74.94
0.437	24.40	Average	H	17.73	0.13	42.26	-37.74	14.79	52.53
0.880	22.00	Quasi Peak	H	18.00	0.19	40.19	0.19	28.71	28.52
2.340	7.50	Quasi Peak	H	18.23	0.24	25.97	-14.03	20.22	34.25

Above 30 MHz

Radiated Emissions			Ant	Correction Factors		Total	Limit	
Frequency (MHz)	Reading (dBμV)	Detect Mode	Pol.	AF (dB/m)	AMP + CL (dB)	Actual (dBμV/m)	Limit (dBμV/m)	Margin (dB)
39.94	35.50	Peak	V	19.88	-26.94	28.44	40.00	11.56
56.64	42.00	Peak	V	18.97	-26.71	34.26	40.00	5.74
97.25	37.10	Peak	V	16.65	-26.19	27.56	43.50	15.94
107.68	35.10	Peak	V	16.76	-26.06	25.80	43.50	17.70
206.10	33.40	Peak	H	16.62	-24.82	25.20	43.50	18.30
Above 300.00	Not detected	-	-	-	-	-	-	-

Test Condition: 4.5 W Operating mode with client device (1 % battery status of client device)

Ant. 1 (119 kHz ~ 122 kHz)

Below 30 MHz

Radiated Emissions			Ant.	Correction Factors		Total		Limit	
Frequency (MHz)	Reading (dB μ V)	Detect Mode	Pol.	AF (dB/m)	CL (dB)	Actual (dB μ V/m) at 3 m	Actual (dB μ V/m) at 300 m or 30 m	Limit (dB μ V/m) at 300 m or 30 m	Margin (dB)
0.036	37.40	Average	H	17.89	0.02	55.31	-24.69	36.48	61.17
0.082	17.90	Average	H	17.83	0.03	35.76	-44.24	29.33	73.57
0.360	49.20	Average	H	17.77	0.12	67.09	-12.91	16.48	29.39
0.600	40.00	Quasi Peak	H	17.78	0.16	57.94	17.94	32.04	14.10
0.840	32.90	Quasi Peak	H	17.97	0.19	51.06	11.06	29.12	18.06

Above 30 MHz

Radiated Emissions			Ant.	Correction Factors		Total	Limit	
Frequency (MHz)	Reading (dB μ V)	Detect Mode	Pol.	AF (dB/m)	AMP + CL (dB)	Actual (dB μ V/m)	Limit (dB μ V/m)	Margin (dB)
35.58	36.90	Peak	V	17.91	-27.01	27.80	40.00	12.20
56.68	39.40	Peak	V	18.96	-26.71	31.65	40.00	8.35
95.11	36.70	Peak	V	16.41	-26.21	26.90	43.50	16.60
193.77	33.90	Peak	V	16.75	-24.95	25.70	43.50	17.80
207.71	33.70	Peak	H	16.65	-24.80	25.55	43.50	17.95
Above 300.00	Not detected	-	-	-	-	-	-	-

Ant. 1 (126.2 kHz ~ 129.2 kHz)

Below 30 MHz

Radiated Emissions			Ant.	Correction Factors		Total		Limit	
Frequency (MHz)	Reading (dB μ V)	Detect Mode	Pol.	AF (dB/m)	CL (dB)	Actual (dB μ V/m) at 3 m	Actual (dB μ V/m) at 300 m or 30 m	Limit (dB μ V/m) at 300 m or 30 m	Margin (dB)
0.026	28.50	Average	H	18.02	0.02	46.54	-33.46	39.30	72.76
0.036	37.40	Average	H	17.89	0.02	55.31	-24.69	36.48	61.17
0.077	31.00	Average	H	17.83	0.03	48.86	-31.14	29.87	61.01
0.379	48.80	Average	H	17.76	0.12	66.68	-13.32	16.03	29.35
0.631	41.90	Quasi Peak	H	17.80	0.16	59.86	19.86	31.60	11.74
0.882	32.30	Quasi Peak	H	18.01	0.19	50.50	10.50	28.69	18.19

Above 30 MHz

Radiated Emissions			Ant	Correction Factors		Total	Limit	
Frequency (MHz)	Reading (dB μ V)	Detect Mode	Pol.	AF (dB/m)	AMP + CL (dB)	Actual (dB μ V/m)	Limit (dB μ V/m)	Margin (dB)
34.93	37.40	Peak	V	17.46	-27.02	27.84	40.00	12.16
56.19	40.20	Peak	V	19.06	-26.72	32.54	40.00	7.46
91.88	38.60	Peak	V	15.65	-26.25	28.00	43.50	15.50
98.59	36.00	Peak	V	16.86	-26.16	26.70	43.50	16.80
197.37	33.00	Peak	V	17.20	-24.91	25.29	43.50	18.21
207.43	33.90	Peak	H	16.65	-24.82	25.73	43.50	17.77
Above 300.00	Not detected	-	-	-	-	-	-	-

Ant. 6 (119 kHz ~ 122 kHz)

Below 30 MHz

Radiated Emissions			Ant.	Correction Factors		Total		Limit	
Frequency (MHz)	Reading (dB μ V)	Detect Mode	Pol.	AF (dB/m)	CL (dB)	Actual (dB μ V/m) at 3 m	Actual (dB μ V/m) at 300 m or 30 m	Limit (dB μ V/m) at 300 m or 30 m	Margin (dB)
0.036	38.80	Average	H	17.89	0.02	56.71	-23.29	36.48	59.77
0.080	17.80	Average	H	17.83	0.03	35.66	-4.34	49.54	53.88
0.366	48.90	Average	H	17.77	0.12	66.79	-13.21	16.33	29.54
0.853	32.80	Quasi Peak	H	17.98	0.19	50.97	10.97	28.99	18.02

Above 30 MHz

Radiated Emissions			Ant	Correction Factors		Total	Limit	
Frequency (MHz)	Reading (dB μ V)	Detect Mode	Pol.	AF (dB/m)	AMP + CL (dB)	Actual (dB μ V/m)	Limit (dB μ V/m)	Margin (dB)
38.57	6.50	Peak	V	19.39	-26.96	-1.07	40.00	41.07
57.48	41.90	Peak	V	18.76	-26.70	33.96	40.00	6.04
97.29	38.40	Peak	V	16.66	-26.19	28.87	43.50	14.63
205.77	33.30	Peak	H	16.62	-24.83	25.09	43.50	18.41
Above 900.00	Not detected	-	-	-	-	-	-	-

Ant. 6 (126.2 kHz ~ 129.2 kHz)

Below 30 MHz

Radiated Emissions			Ant.	Correction Factors		Total		Limit	
Frequency (MHz)	Reading (dB μ V)	Detect Mode	Pol.	AF (dB/m)	CL (dB)	Actual (dB μ V/m) at 3 m	Actual (dB μ V/m) at 300 m or 30 m	Limit (dB μ V/m) at 300 m or 30 m	Margin (dB)
0.013	33.20	Average	H	18.41	0.02	51.63	-28.37	45.33	73.70
0.026	33.90	Average	H	18.02	0.02	51.94	-28.06	39.30	67.36
0.036	47.90	Average	H	17.89	0.02	65.81	-14.19	36.48	50.67
0.388	48.20	Average	H	17.76	0.13	66.09	-13.91	15.83	29.74
0.645	40.00	Quasi Peak	H	17.82	0.16	57.98	17.98	31.41	13.43
2.300	33.02	Quasi Peak	H	18.23	0.24	51.49	11.49	20.37	8.88

Above 30 MHz

Radiated Emissions			Ant	Correction Factors		Total	Limit	
Frequency (MHz)	Reading (dB μ V)	Detect Mode	Pol.	AF (dB/m)	AMP + CL (dB)	Actual (dB μ V/m)	Limit (dB μ V/m)	Margin (dB)
38.53	35.60	Peak	V	19.37	-26.96	28.01	40.00	11.99
56.68	41.90	Peak	V	18.96	-26.71	34.15	40.00	5.85
97.29	39.40	Peak	V	16.66	-26.19	29.87	43.50	13.63
208.00	34.60	Peak	V	16.66	-24.80	26.46	43.50	17.04
Above 300.00	Not detected	-	-	-	-	-	-	-

Test Condition: 9 W Operating mode with client device (1 % battery status of client device)

Ant. 1 (136.5 kHz ~ 139.5 kHz)

Below 30 MHz

Radiated Emissions			Ant.	Correction Factors		Total		Limit	
Frequency (MHz)	Reading (dB μ V)	Detect Mode	Pol.	AF (dB/m)	CL (dB)	Actual (dB μ V/m) at 3 m	Actual (dB μ V/m) at 300 m or 30 m	Limit (dB μ V/m) at 300 m or 30 m	Margin (dB)
0.019	30.20	Average	H	18.23	0.02	48.45	-31.55	42.03	73.58
0.036	38.50	Average	H	17.89	0.02	56.41	-23.59	36.48	60.07
0.072	15.60	Average	H	17.84	0.03	33.47	-46.53	30.46	76.99
0.413	49.90	Average	H	17.74	0.13	67.77	-12.23	15.29	27.52
0.689	40.30	Quasi Peak	H	17.85	0.17	58.32	18.32	30.84	12.52
0.967	33.60	Quasi Peak	H	18.07	0.21	51.88	11.88	27.90	16.02

Above 30 MHz

Radiated Emissions			Ant	Correction Factors		Total	Limit	
Frequency (MHz)	Reading (dB μ V)	Detect Mode	Pol.	AF (dB/m)	AMP + CL (dB)	Actual (dB μ V/m)	Limit (dB μ V/m)	Margin (dB)
38.41	36.30	Peak	V	19.31	-26.97	28.64	40.00	11.36
56.39	40.50	Peak	V	19.02	-26.72	32.80	40.00	7.20
98.91	37.10	Peak	V	16.89	-26.16	27.83	43.50	15.67
191.63	34.20	Peak	V	16.43	-24.98	25.65	43.50	17.85
288.79	37.80	Peak	H	18.98	-24.16	32.62	46.00	13.38
370.35	34.90	Peak	V	20.51	-24.19	31.22	46.00	14.78
Above 400.00	Not detected	-	-	-	-	-	-	-

Ant. 6 (144.5 kHz ~ 147.5 kHz)

Below 30 MHz

Radiated Emissions			Ant.	Correction Factors		Total		Limit	
Frequency (MHz)	Reading (dB μ V)	Detect Mode	Pol.	AF (dB/m)	CL (dB)	Actual (dB μ V/m) at 3 m	Actual (dB μ V/m) at 300 m or 30 m	Limit (dB μ V/m) at 300 m or 30 m	Margin (dB)
0.026	26.70	Average	H	18.02	0.02	44.74	-35.26	39.30	74.56
0.036	39.80	Average	H	17.89	0.02	57.71	-22.29	36.48	58.77
0.076	15.60	Average	H	17.83	0.03	33.46	-46.54	29.99	76.53
0.438	50.00	Average	H	17.73	0.13	67.86	-12.14	14.77	26.91
0.729	40.40	Quasi Peak	H	17.88	0.17	58.45	18.45	30.35	11.90
1.020	33.30	Quasi Peak	H	18.10	0.21	51.61	11.61	27.43	15.82

Above 30 MHz

Radiated Emissions			Ant.	Correction Factors		Total	Limit	
Frequency (MHz)	Reading (dB μ V)	Detect Mode	Pol.	AF (dB/m)	AMP + CL (dB)	Actual (dB μ V/m)	Limit (dB μ V/m)	Margin (dB)
38.89	35.50	Peak	V	19.55	-26.96	28.09	40.00	11.91
55.34	39.30	Peak	V	19.30	-26.73	31.87	40.00	8.13
97.29	37.20	Peak	V	16.66	-26.19	27.67	43.50	15.83
107.68	34.60	Peak	V	16.76	-26.06	25.30	43.50	18.20
207.55	33.90	Peak	H	16.65	-24.80	25.75	43.50	17.75
Above 300.00	Not detected	-	-	-	-	-	-	-

Test Condition: 2 W & 4.5W Operating mode with 3 client devices (1 % battery status of client device)

Ant. 1 (119 kHz ~ 122 kHz) & Ant. 6 (119 kHz ~ 122 kHz) & Ant. 7 (144.5 kHz ~ 147.5 kHz)

Below 30 MHz

Radiated Emissions			Ant.	Correction Factors		Total		Limit	
Frequency (MHz)	Reading (dB μ V)	Detect Mode	Pol.	AF (dB/m)	CL (dB)	Actual (dB μ V/m) at 3 m	Actual (dB μ V/m) at 300 m or 30 m	Limit (dB μ V/m) at 300 m or 30 m	Margin (dB)
0.018	28.10	Average	H	18.26	0.02	46.38	-33.62	42.50	76.12
0.036	38.70	Average	H	17.89	0.02	56.61	-23.39	36.48	59.87
0.076	21.70	Average	H	17.83	0.03	39.56	-40.44	29.99	70.43
0.363	47.00	Average	H	17.77	0.12	64.89	-15.11	16.41	31.52
0.601	37.70	Quasi Peak	H	17.78	0.16	55.64	15.64	32.03	16.39
0.853	32.50	Quasi Peak	H	17.98	0.19	50.67	10.67	28.99	18.32

Above 30 MHz

Radiated Emissions			Ant	Correction Factors		Total	Limit	
Frequency (MHz)	Reading (dB μ V)	Detect Mode	Pol.	AF (dB/m)	AMP + CL (dB)	Actual (dB μ V/m)	Limit (dB μ V/m)	Margin (dB)
35.70	39.40	Peak	V	17.99	-27.01	30.38	40.00	9.62
55.62	35.40	Peak	V	19.21	-26.73	27.88	40.00	12.12
60.52	36.20	Peak	V	17.94	-26.65	27.49	40.00	12.51
82.26	37.70	Peak	V	12.38	-26.38	23.70	40.00	16.30
99.19	33.20	Peak	H	16.92	-26.16	23.96	43.50	19.54
221.54	36.90	Peak	H	17.39	-24.68	29.61	46.00	16.39
Above 300.00	Not detected	-	-	-	-	-	-	-

Ant. 1 (119 kHz ~ 122 kHz) & Ant. 6 (126.2 kHz ~ 129.2 kHz) & Ant. 7 (144.5 kHz ~ 147.5 kHz)

Below 30 MHz

Radiated Emissions			Ant.	Correction Factors		Total		Limit	
Frequency (MHz)	Reading (dB μ V)	Detect Mode	Pol.	AF (dB/m)	CL (dB)	Actual (dB μ V/m) at 3 m	Actual (dB μ V/m) at 300 m or 30 m	Limit (dB μ V/m) at 300 m or 30 m	Margin (dB)
0.036	38.70	Average	H	17.89	0.02	56.61	-23.39	36.48	59.87
0.078	18.10	Average	H	17.83	0.03	35.96	-44.04	29.76	73.80
0.387	47.20	Average	H	17.76	0.13	65.09	-14.91	15.85	30.76
0.601	38.80	Quasi Peak	H	17.78	0.16	56.74	16.74	32.03	15.29
0.840	31.60	Quasi Peak	H	17.97	0.19	49.76	9.76	29.12	19.36

Above 30 MHz

Radiated Emissions			Ant	Correction Factors		Total	Limit	
Frequency (MHz)	Reading (dB μ V)	Detect Mode	Pol.	AF (dB/m)	AMP + CL (dB)	Actual (dB μ V/m)	Limit (dB μ V/m)	Margin (dB)
35.86	40.90	Peak	V	18.10	-27.01	31.99	40.00	8.01
45.72	35.40	Peak	V	20.60	-26.87	29.13	40.00	10.87
56.19	38.40	Peak	V	19.06	-26.72	30.74	40.00	9.26
79.59	41.50	Peak	V	11.76	-26.40	26.86	40.00	13.14
99.48	36.20	Peak	H	16.95	-26.16	26.99	43.50	16.51
836.43	35.60	Peak	H	27.30	-22.77	40.13	46.00	5.87
Above 900.00	Not detected	-	-	-	-	-	-	-

Ant. 1 (126.2 kHz ~ 129.2 kHz) & Ant. 6 (119 kHz ~ 122 kHz) & Ant. 7 (144.5 kHz ~ 147.5 kHz)

Below 30 MHz

Radiated Emissions			Ant.	Correction Factors		Total		Limit	
Frequency (MHz)	Reading (dB μ V)	Detect Mode	Pol.	AF (dB/m)	CL (dB)	Actual (dB μ V/m) at 3 m	Actual (dB μ V/m) at 300 m or 30 m	Limit (dB μ V/m) at 300 m or 30 m	Margin (dB)
0.021	22.00	Average	H	18.17	0.02	40.19	-39.81	41.16	80.97
0.036	38.50	Average	H	17.89	0.02	56.41	-23.59	36.48	60.07
0.064	14.30	Average	H	17.85	0.03	32.18	-47.82	31.48	79.30
0.370	42.20	Average	H	17.77	0.12	60.09	-19.91	16.24	36.15
0.611	36.10	Quasi Peak	H	17.79	0.16	54.05	14.05	31.88	17.83
0.855	29.94	Quasi Peak	H	17.98	0.19	48.11	8.11	28.96	20.85

Above 30 MHz

Radiated Emissions			Ant	Correction Factors		Total	Limit	
Frequency (MHz)	Reading (dB μ V)	Detect Mode	Pol.	AF (dB/m)	AMP + CL (dB)	Actual (dB μ V/m)	Limit (dB μ V/m)	Margin (dB)
34.97	39.80	Peak	V	17.48	-27.02	30.26	40.00	9.74
38.49	37.30	Peak	V	19.35	-26.96	29.69	40.00	10.31
60.88	37.10	Peak	V	17.84	-26.65	28.29	40.00	11.71
82.99	37.50	Peak	V	12.60	-26.36	23.74	40.00	16.26
98.87	32.90	Peak	H	16.89	-26.16	23.63	43.50	19.87
193.89	32.10	Peak	H	16.78	-24.95	23.93	43.50	19.57
Above 200.00	Not detected	-	-	-	-	-	-	-

Ant. 1 (126.2 kHz ~ 129.2 kHz) & Ant. 6 (126.2 kHz ~ 129.2 kHz) & Ant. 7 (144.5 kHz ~ 147.5 kHz)

Below 30 MHz

Radiated Emissions			Ant.	Correction Factors		Total		Limit	
Frequency (MHz)	Reading (dB μ V)	Detect Mode	Pol.	AF (dB/m)	CL (dB)	Actual (dB μ V/m) at 3 m	Actual (dB μ V/m) at 300 m or 30 m	Limit (dB μ V/m) at 300 m or 30 m	Margin (dB)
0.036	39.70	Average	H	17.89	0.02	57.61	-22.39	36.48	58.87
0.076	17.60	Average	H	17.83	0.03	35.46	-44.54	29.99	74.53
0.382	45.10	Average	H	17.76	0.13	62.99	-17.01	15.96	32.97
0.632	38.00	Quasi Peak	H	17.81	0.16	55.97	15.97	31.59	15.62
0.885	32.33	Quasi Peak	H	18.01	0.19	50.53	10.53	28.67	18.14

Above 30 MHz

Radiated Emissions			Ant	Correction Factors		Total	Limit	
Frequency (MHz)	Reading (dB μ V)	Detect Mode	Pol.	AF (dB/m)	AMP + CL (dB)	Actual (dB μ V/m)	Limit (dB μ V/m)	Margin (dB)
37.80	37.50	Peak	V	19.00	-26.98	29.52	40.00	10.48
53.32	34.30	Peak	V	19.74	-26.76	27.28	40.00	12.72
60.35	36.30	Peak	V	18.00	-26.66	27.64	40.00	12.36
78.74	37.30	Peak	V	11.70	-26.41	22.59	40.00	17.41
97.29	34.30	Peak	H	16.66	-26.19	24.77	43.50	18.73
193.00	31.90	Peak	H	16.60	-24.96	23.54	43.50	19.96
Above 200.00	Not detected	-	-	-	-	-	-	-

Test Condition: 2 W & 7.5W Operating mode with 3 client devices (1 % battery status of client device)

Ant. 1 (136.5 kHz ~ 139.5 kHz) & Ant. 6 (136.5 kHz ~ 139.5 kHz) & Ant. 7 (144.5 kHz ~ 147.5 kHz)

Below 30 MHz

Radiated Emissions			Ant.	Correction Factors		Total		Limit	
Frequency (MHz)	Reading (dBμV)	Detect Mode	Pol.	AF (dB/m)	CL (dB)	Actual (dBμV/m) at 3 m	Actual (dBμV/m) at 300 m or 30 m	Limit (dBμV/m) at 300 m or 30 m	Margin (dB)
0.036	46.40	Average	H	17.89	0.02	64.31	-15.69	36.48	52.17
0.076	21.60	Average	H	17.83	0.03	39.46	-40.54	29.99	70.53
0.414	47.90	Average	H	17.74	0.13	65.77	-14.23	15.26	29.49
0.689	39.80	Quasi Peak	H	17.85	0.17	57.82	17.82	30.84	13.02
0.967	32.70	Quasi Peak	H	18.07	0.21	50.98	10.98	27.90	16.92

Above 30 MHz

Radiated Emissions			Ant	Correction Factors		Total	Limit	
Frequency (MHz)	Reading (dBμV)	Detect Mode	Pol.	AF (dB/m)	AMP + CL (dB)	Actual (dBμV/m)	Limit (dBμV/m)	Margin (dB)
35.46	41.60	Peak	V	17.82	-27.01	32.41	40.00	7.59
45.12	33.80	Peak	V	20.60	-26.87	27.53	40.00	12.47
56.59	39.10	Peak	V	18.98	-26.71	31.37	40.00	8.63
79.39	40.70	Peak	V	11.74	-26.41	26.03	40.00	13.97
99.23	36.00	Peak	H	16.92	-26.16	26.76	43.50	16.74
191.10	33.90	Peak	H	16.32	-24.98	25.24	43.50	18.26
Above 900.00	Not detected	-	-	-	-	-	-	-

Ant. 1 (136.5 kHz ~ 139.5 kHz) & Ant. 6 (126.2 kHz ~ 129.2 kHz) & Ant. 7 (144.5 kHz ~ 147.5 kHz)

Below 30 MHz

Radiated Emissions			Ant.	Correction Factors		Total		Limit	
Frequency (MHz)	Reading (dB μ V)	Detect Mode	Pol.	AF (dB/m)	CL (dB)	Actual (dB μ V/m) at 3 m	Actual (dB μ V/m) at 300 m or 30 m	Limit (dB μ V/m) at 300 m or 30 m	Margin (dB)
0.036	45.90	Average	H	17.89	0.02	63.81	-16.19	36.48	52.67
0.074	25.50	Average	H	17.84	0.03	43.37	-36.63	30.22	66.85
0.413	48.10	Average	H	17.74	0.13	65.97	-14.03	15.29	29.32
0.690	39.90	Quasi Peak	H	17.85	0.17	57.92	17.92	30.83	12.91
0.966	32.70	Quasi Peak	H	18.07	0.21	50.98	10.98	27.90	16.92

Above 30 MHz

Radiated Emissions			Ant	Correction Factors		Total	Limit	
Frequency (MHz)	Reading (dB μ V)	Detect Mode	Pol.	AF (dB/m)	AMP + CL (dB)	Actual (dB μ V/m)	Limit (dB μ V/m)	Margin (dB)
35.50	39.80	Peak	V	17.85	-27.01	30.64	40.00	9.36
38.12	38.40	Peak	V	19.16	-26.97	30.59	40.00	9.41
62.50	37.10	Peak	V	17.30	-26.63	27.77	40.00	12.23
83.63	37.80	Peak	V	12.85	-26.35	24.30	40.00	15.70
99.32	35.50	Peak	H	16.93	-26.16	26.27	43.50	17.23
192.07	33.20	Peak	H	16.51	-24.98	24.73	43.50	18.77
Above 200.00	Not detected	-	-	-	-	-	-	-

Ant. 1 (126.2 kHz ~ 129.2 kHz) & Ant. 6 (144.5 kHz ~ 147.5 kHz) & Ant. 7 (144.5 kHz ~ 147.5 kHz)

Below 30 MHz

Radiated Emissions			Ant.	Correction Factors		Total		Limit	
Frequency (MHz)	Reading (dB μ V)	Detect Mode	Pol.	AF (dB/m)	CL (dB)	Actual (dB μ V/m) at 3 m	Actual (dB μ V/m) at 300 m or 30 m	Limit (dB μ V/m) at 300 m or 30 m	Margin (dB)
0.036	47.10	Average	H	17.89	0.02	65.01	-14.99	36.48	51.47
0.074	23.70	Average	H	17.84	0.03	41.57	-38.43	30.22	68.65
0.438	46.60	Average	H	17.73	0.13	64.46	-15.54	14.77	30.31
0.729	36.90	Quasi Peak	H	17.88	0.17	54.95	14.95	30.35	15.40
2.302	26.91	Quasi Peak	H	18.23	0.24	45.38	5.38	20.36	14.98

Above 30 MHz

Radiated Emissions			Ant	Correction Factors		Total	Limit	
Frequency (MHz)	Reading (dB μ V)	Detect Mode	Pol.	AF (dB/m)	AMP + CL (dB)	Actual (dB μ V/m)	Limit (dB μ V/m)	Margin (dB)
38.00	37.80	Peak	V	19.10	-26.97	29.93	40.00	10.07
60.88	37.50	Peak	V	17.84	-26.65	28.69	40.00	11.31
79.92	37.00	Peak	V	11.79	-26.40	22.39	40.00	17.61
95.52	34.80	Peak	H	16.45	-26.20	25.05	43.50	18.45
191.47	32.70	Peak	H	16.39	-24.98	24.11	43.50	19.39
Above 200.00	Not detected	-	-	-	-	-	-	-

Ant. 1 (126.2 kHz ~ 129.2 kHz) & Ant. 6 (126.2 kHz ~ 129.2 kHz) & Ant. 7 (144.5 kHz ~ 147.5 kHz)

Below 30 MHz

Radiated Emissions			Ant.	Correction Factors		Total		Limit	
Frequency (MHz)	Reading (dB μ V)	Detect Mode	Pol.	AF (dB/m)	CL (dB)	Actual (dB μ V/m) at 3 m	Actual (dB μ V/m) at 300 m or 30 m	Limit (dB μ V/m) at 300 m or 30 m	Margin (dB)
0.036	47.90	Average	H	17.89	0.02	65.81	-14.19	36.48	50.67
0.074	23.70	Average	H	17.84	0.03	41.57	-38.43	30.22	68.65
0.382	44.60	Average	H	17.76	0.13	62.49	-17.51	15.96	33.47
0.631	38.20	Quasi Peak	H	17.80	0.16	56.16	16.16	31.60	15.44
0.880	35.00	Quasi Peak	H	18.00	0.19	53.19	13.19	28.71	15.52

Above 30 MHz

Radiated Emissions			Ant	Correction Factors		Total	Limit	
Frequency (MHz)	Reading (dB μ V)	Detect Mode	Pol.	AF (dB/m)	AMP + CL (dB)	Actual (dB μ V/m)	Limit (dB μ V/m)	Margin (dB)
35.46	41.20	Peak	V	17.82	-27.01	32.01	40.00	7.99
38.21	38.30	Peak	V	19.21	-26.97	30.54	40.00	9.46
60.07	36.90	Peak	V	18.08	-26.66	28.32	40.00	11.68
83.63	37.20	Peak	V	12.85	-26.35	23.70	40.00	16.30
98.26	33.70	Peak	H	16.83	-26.17	24.36	43.50	19.14
192.52	32.40	Peak	H	16.55	-24.96	23.99	43.50	19.51
Above 200.00	Not detected	-	-	-	-	-	-	-

Test Condition: 2 W & 9W Operating mode with 3 client devices (1 % battery status of client device)

Ant. 1 (136.5 kHz ~ 139.5 kHz) & Ant. 6 (144.5 kHz ~ 147.5 kHz) & Ant. 7 (144.5 kHz ~ 147.5 kHz)

Below 30 MHz

Radiated Emissions			Ant.	Correction Factors		Total		Limit	
Frequency (MHz)	Reading (dB μ V)	Detect Mode	Pol.	AF (dB/m)	CL (dB)	Actual (dB μ V/m) at 3 m	Actual (dB μ V/m) at 300 m or 30 m	Limit (dB μ V/m) at 300 m or 30 m	Margin (dB)
0.036	38.30	Average	H	17.89	0.02	56.21	-23.79	36.48	60.27
0.072	16.60	Average	H	17.84	0.03	34.47	-45.53	30.46	75.99
0.438	49.20	Average	H	17.73	0.13	67.06	-12.94	14.77	27.71
0.728	39.00	Quasi Peak	H	17.88	0.17	57.05	17.05	30.36	13.31
1.023	33.10	Quasi Peak	H	18.10	0.21	51.41	11.41	27.41	16.00

Above 30 MHz

Radiated Emissions			Ant	Correction Factors		Total	Limit	
Frequency (MHz)	Reading (dB μ V)	Detect Mode	Pol.	AF (dB/m)	AMP + CL (dB)	Actual (dB μ V/m)	Limit (dB μ V/m)	Margin (dB)
38.73	38.60	Peak	V	19.47	-26.96	31.11	40.00	8.89
56.31	42.40	Peak	V	19.04	-26.72	34.72	40.00	5.28
97.29	39.20	Peak	V	16.66	-26.19	29.67	43.50	13.83
193.12	34.40	Peak	H	16.62	-24.96	26.06	43.50	17.44
385.34	32.10	Peak	V	21.11	-24.25	28.96	46.00	17.04
740.89	31.70	Peak	H	26.62	-23.49	34.83	46.00	11.17
Above 800.00	Not detected	-	-	-	-	-	-	-

Test Condition: 2 W & 4.5W & 9W Operating mode with 3 client devices (1 % battery status of client device)

Ant. 1 (136.5 kHz ~ 139.5 kHz) & Ant. 6 (119 kHz ~ 122 kHz) & Ant. 7 (144.5 kHz ~ 147.5 kHz)

Below 30 MHz

Radiated Emissions			Ant.	Correction Factors		Total		Limit	
Frequency (MHz)	Reading (dB μ V)	Detect Mode	Pol.	AF (dB/m)	CL (dB)	Actual (dB μ V/m) at 3 m	Actual (dB μ V/m) at 300 m or 30 m	Limit (dB μ V/m) at 300 m or 30 m	Margin (dB)
0.036	38.40	Average	H	17.89	0.02	56.31	-23.69	36.48	60.17
0.072	19.10	Average	H	17.84	0.03	36.97	-43.03	30.46	73.49
0.415	48.10	Average	H	17.74	0.13	65.97	-14.03	15.24	29.27
0.610	37.80	Quasi Peak	H	17.79	0.16	55.75	15.75	31.90	16.15
0.689	38.40	Quasi Peak	H	17.85	0.17	56.42	16.42	30.84	14.42

Above 30 MHz

Radiated Emissions			Ant	Correction Factors		Total	Limit	
Frequency (MHz)	Reading (dB μ V)	Detect Mode	Pol.	AF (dB/m)	AMP + CL (dB)	Actual (dB μ V/m)	Limit (dB μ V/m)	Margin (dB)
38.89	36.60	Peak	V	19.55	-26.96	29.19	40.00	10.81
57.48	41.90	Peak	V	18.76	-26.70	33.96	40.00	6.04
97.29	38.90	Peak	V	16.66	-26.19	29.37	43.50	14.13
160.02	35.90	Peak	V	14.40	-25.40	24.90	43.50	18.60
205.00	34.50	Peak	H	16.60	-24.83	26.27	43.50	17.23
355.84	35.10	Peak	H	20.68	-24.10	31.68	46.00	14.32
Above 400.00	Not detected	-	-	-	-	-	-	-

Ant. 1 (136.5 kHz ~ 139.5 kHz) & Ant. 6 (126.2 kHz ~ 129.2 kHz) & Ant. 7 (144.5 kHz ~ 147.5 kHz)

Below 30 MHz

Radiated Emissions			Ant.	Correction Factors		Total		Limit	
Frequency (MHz)	Reading (dB μ V)	Detect Mode	Pol.	AF (dB/m)	CL (dB)	Actual (dB μ V/m) at 3 m	Actual (dB μ V/m) at 300 m or 30 m	Limit (dB μ V/m) at 300 m or 30 m	Margin (dB)
0.022	25.80	Average	H	18.14	0.02	43.96	-36.04	40.76	76.80
0.036	38.60	Average	H	17.89	0.02	56.51	-23.49	36.48	59.97
0.044	21.00	Average	H	17.88	0.02	38.90	-41.10	34.74	75.84
0.415	37.80	Average	H	17.74	0.13	55.67	-24.33	15.24	39.57
0.690	28.80	Quasi Peak	H	17.85	0.17	46.82	6.82	30.83	24.01
0.967	22.30	Quasi Peak	H	18.07	0.21	40.58	0.58	27.90	27.32

Above 30 MHz

Radiated Emissions			Ant	Correction Factors		Total	Limit	
Frequency (MHz)	Reading (dB μ V)	Detect Mode	Pol.	AF (dB/m)	AMP + CL (dB)	Actual (dB μ V/m)	Limit (dB μ V/m)	Margin (dB)
39.05	37.60	Peak	V	19.62	-26.96	30.26	40.00	9.74
56.55	42.10	Peak	V	18.99	-26.71	34.38	40.00	5.62
97.33	39.60	Peak	V	16.67	-26.19	30.08	43.50	13.42
159.98	36.30	Peak	V	14.40	-25.40	25.30	43.50	18.20
204.84	34.90	Peak	H	16.61	-24.83	26.68	43.50	16.82
288.79	38.10	Peak	H	18.98	-24.16	32.92	46.00	13.08
Above 300.00	Not detected	-	-	-	-	-	-	-

Ant. 1 (119 kHz ~ 122 kHz) & Ant. 6 (144.5 kHz ~ 147.5 kHz) & Ant. 7 (144.5 kHz ~ 147.5 kHz)

Below 30 MHz

Radiated Emissions			Ant.	Correction Factors		Total		Limit	
Frequency (MHz)	Reading (dB μ V)	Detect Mode	Pol.	AF (dB/m)	CL (dB)	Actual (dB μ V/m) at 3 m	Actual (dB μ V/m) at 300 m or 30 m	Limit (dB μ V/m) at 300 m or 30 m	Margin (dB)
0.036	38.70	Average	H	17.89	0.02	56.61	-23.39	36.48	59.87
0.072	19.20	Average	H	17.84	0.03	37.07	-42.93	30.46	73.39
0.437	49.60	Average	H	17.73	0.13	67.46	-12.54	14.79	27.33
0.599	37.11	Quasi Peak	H	17.78	0.15	55.04	15.04	32.06	17.02
0.729	40.20	Quasi Peak	H	17.88	0.17	58.25	18.25	30.35	12.10

Above 30 MHz

Radiated Emissions			Ant	Correction Factors		Total	Limit	
Frequency (MHz)	Reading (dB μ V)	Detect Mode	Pol.	AF (dB/m)	AMP + CL (dB)	Actual (dB μ V/m)	Limit (dB μ V/m)	Margin (dB)
34.65	41.70	Peak	V	17.29	-27.03	31.96	40.00	8.04
45.12	35.90	Peak	V	20.60	-26.87	29.63	40.00	10.37
56.72	36.40	Peak	V	18.96	-26.71	28.65	40.00	11.35
107.68	34.40	Peak	V	16.76	-26.06	25.10	43.50	18.40
175.95	34.60	Peak	H	14.90	-25.18	24.32	43.50	19.18
373.34	33.20	Peak	H	20.63	-24.20	29.63	46.00	16.37
Above 400.00	Not detected	-	-	-	-	-	-	-

Ant. 1 (126.2 kHz ~ 129.2 kHz) & Ant. 6 (144.5 kHz ~ 147.5 kHz) & Ant. 7 (144.5 kHz ~ 147.5 kHz)

Below 30 MHz

Radiated Emissions			Ant.	Correction Factors		Total		Limit	
Frequency (MHz)	Reading (dB μ V)	Detect Mode	Pol.	AF (dB/m)	CL (dB)	Actual (dB μ V/m) at 3 m	Actual (dB μ V/m) at 300 m or 30 m	Limit (dB μ V/m) at 300 m or 30 m	Margin (dB)
0.036	38.70	Average	H	17.89	0.02	56.61	-23.39	36.48	59.87
0.076	18.50	Average	H	17.83	0.03	36.36	-43.64	29.99	73.63
0.438	49.70	Average	H	17.73	0.13	67.56	-12.44	14.77	27.21
0.729	40.00	Quasi Peak	H	17.88	0.17	58.05	18.05	30.35	12.30
1.021	33.20	Quasi Peak	H	18.10	0.21	51.51	11.51	27.42	15.91

Above 30 MHz

Radiated Emissions			Ant	Correction Factors		Total	Limit	
Frequency (MHz)	Reading (dB μ V)	Detect Mode	Pol.	AF (dB/m)	AMP + CL (dB)	Actual (dB μ V/m)	Limit (dB μ V/m)	Margin (dB)
35.78	39.10	Peak	V	18.05	-27.01	30.14	40.00	9.86
53.36	35.70	Peak	V	19.73	-26.76	28.67	40.00	11.33
60.88	36.60	Peak	V	17.84	-26.65	27.79	40.00	12.21
79.35	37.80	Peak	V	11.74	-26.41	23.13	40.00	16.87
98.75	33.40	Peak	H	16.88	-26.16	24.12	43.50	19.38
194.09	32.20	Peak	H	16.81	-24.95	24.06	43.50	19.44
Above 200.00	Not detected	-	-	-	-	-	-	-

Test Condition: Ping mode with client device (Standby mode)

Ant. All (136.5 kHz ~ 139.5 kHz & 144.5 kHz ~ 147.5 kHz)

Below 30 MHz

Radiated Emissions			Ant.	Correction Factors		Total		Limit	
Frequency (MHz)	Reading (dBμV)	Detect Mode	Pol.	AF (dB/m)	CL (dB)	Actual (dBμV/m) at 3 m	Actual (dBμV/m) at 300 m or 30 m	Limit (dBμV/m) at 300 m or 30 m	Margin (dB)
0.036	48.90	Average	H	17.89	0.02	66.81	-13.19	36.48	49.67
0.089	11.00	Average	H	17.82	0.03	28.85	-51.15	28.62	79.77
0.437	50.45	Average	H	17.73	0.13	68.31	-11.69	14.79	26.48
0.730	34.80	Quasi Peak	H	17.88	0.17	52.85	12.85	30.34	17.49
2.350	32.30	Quasi Peak	H	18.24	0.24	50.78	10.78	20.18	9.40

Above 30 MHz

Radiated Emissions			Ant	Correction Factors		Total	Limit	
Frequency (MHz)	Reading (dBμV)	Detect Mode	Pol.	AF (dB/m)	AMP + CL (dB)	Actual (dBμV/m)	Limit (dBμV/m)	Margin (dB)
37.64	36.70	Peak	V	18.92	-26.98	28.64	40.00	11.36
54.74	34.50	Peak	V	19.45	-26.74	27.21	40.00	12.79
61.12	36.20	Peak	V	17.76	-26.65	27.31	40.00	12.69
79.43	37.40	Peak	V	11.74	-26.41	22.73	40.00	17.27
97.86	33.60	Peak	H	16.77	-26.17	24.20	43.50	19.30
Above 100.00	Not detected	-	-	-	-	-	-	-

Remark;

- According to §15.31 (f)(2),
 - 300 m Result (dBμV/m) = 3 m Result (dBμV/m) - 40log (300/3) (dBμV/m)
 - 30 m Result (dBμV/m) = 3 m Result (dBμV/m) - 40log (30/3) (dBμV/m)
- According to field strength table of general requirement in §15.209 (a), field strength limits below 1.705 MHz were calculated as below.
 - 9 kHz to 490 kHz: 20log (2 400 / F (kHz)) at 300 m (dBμV/m)
 - 490 kHz to 1.705 MHz: 20log (24 000 / F (kHz)) at 30 m (dBμV/m)
- According to §15.209 (d), the measurements were tested by using Quasi peak detector except for the frequency bands 9-90 kHz, 110-490 kHz and above 1 GHz in these three bands on measurements employing an average detector.
- The limit above was calculated based on table of §15.209 (a).
- Radiated spurious emission measurement as below 30 MHz.
 (Actual (dBμA/m) at 3m = Reading (dBμV) + AF (dB/m) + CL (dB))
- Radiated spurious emission measurement as above 30 MHz.
 (Actual (dBμA/m) = Reading (dBμV) + AF (dB/m) + CL (dB) + AMP (dB))
- According to §15.31(o), emission levels are not report much lower than the limits by over 20 dB.

- Test plots

Test Condition: 2 W Operating mode with client device (1 % battery status of client device)

Ant. 7 (144.5 kHz ~ 147.5 kHz)

Below 30 MHz

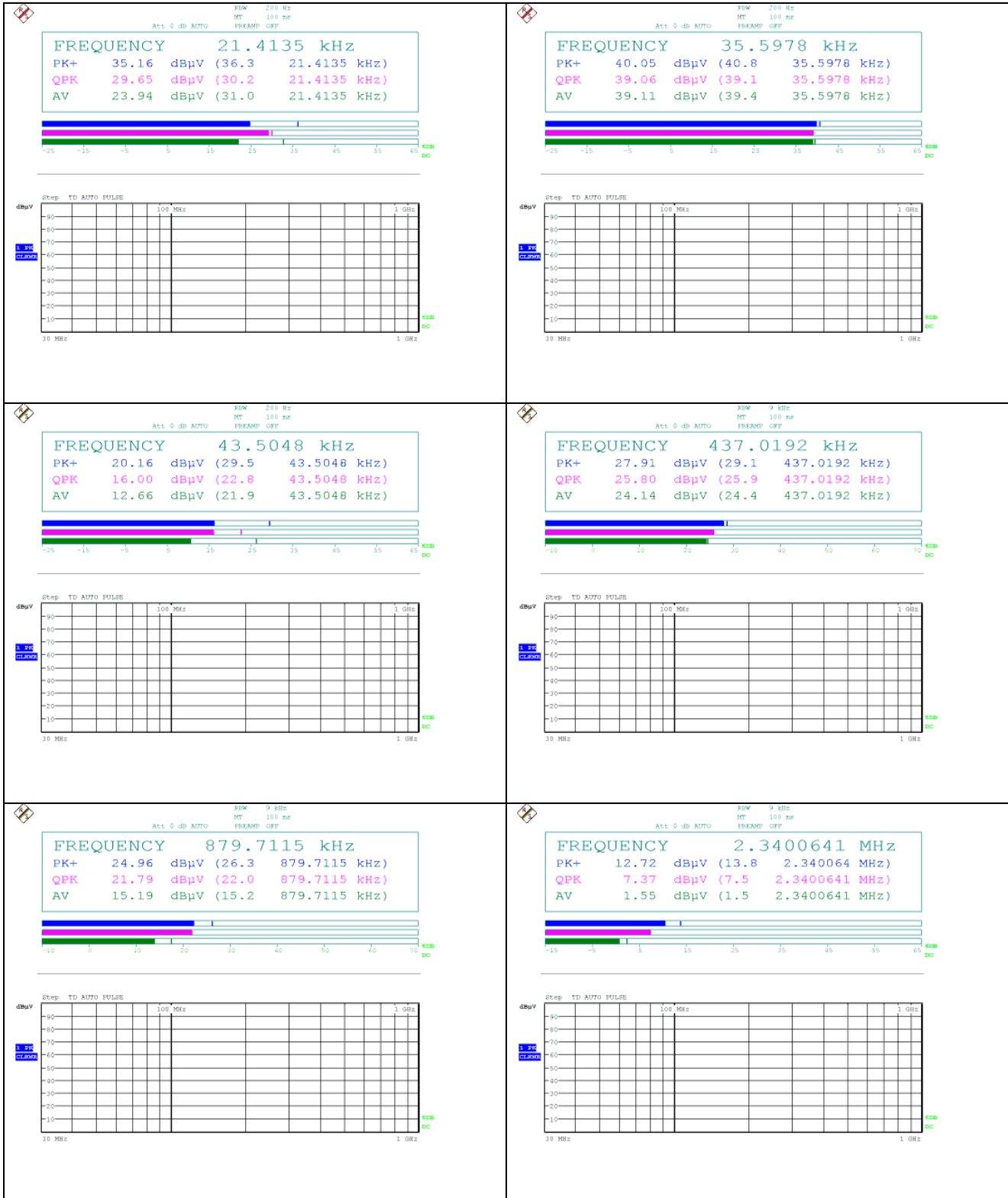

Above 30 MHz

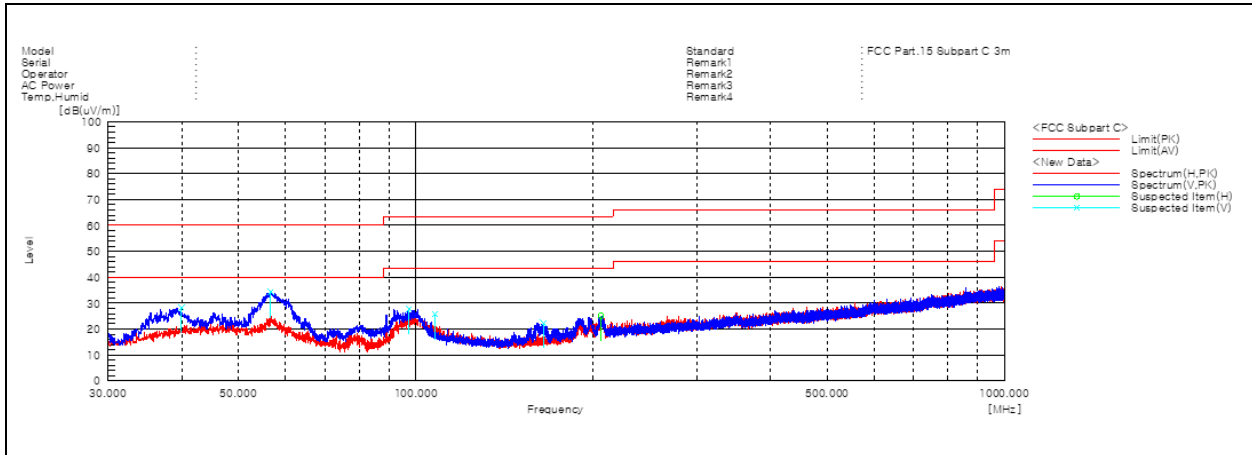

Remark;

- Traces shown in the plot were made by using a peak detector.

Test Condition: 4.5 W Operating mode with client device (1 % battery status of client device)

Ant. 1 (119 kHz ~ 122 kHz)

Below 30 MHz



Above 30 MHz

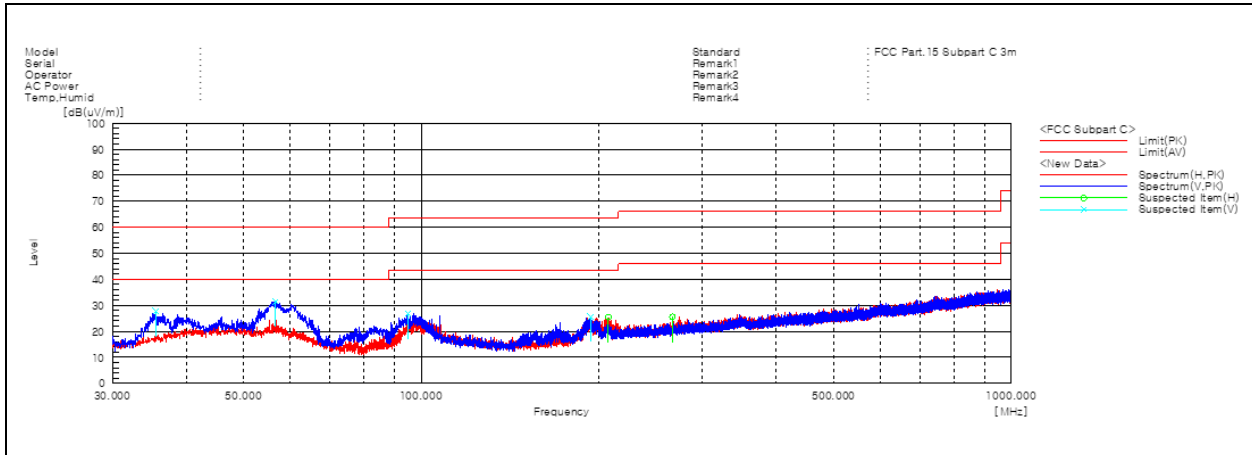

Remark;

- Traces shown in the plot were made by using a peak detector.

Ant. 1 (126.2 kHz ~ 129.2 kHz)

Below 30 MHz

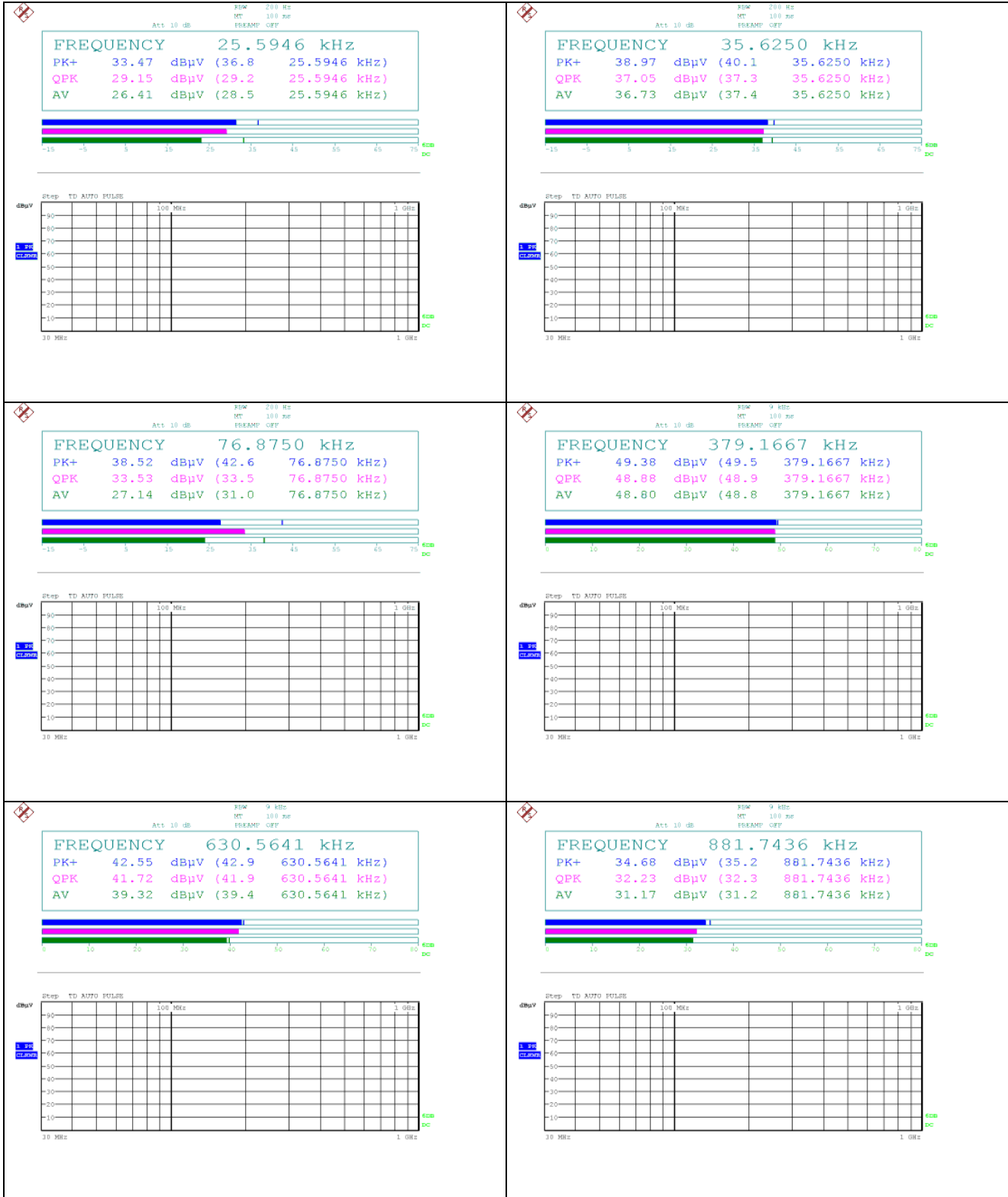

Above 30 MHz

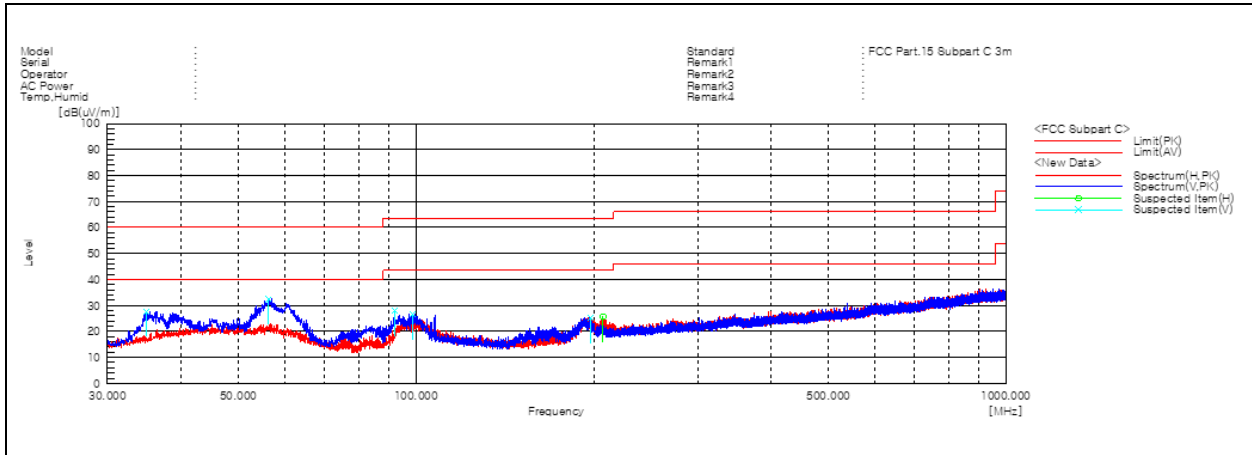

Remark;

- Traces shown in the plot were made by using a peak detector.

Ant. 6 (119 kHz ~ 122 kHz)

Below 30 MHz

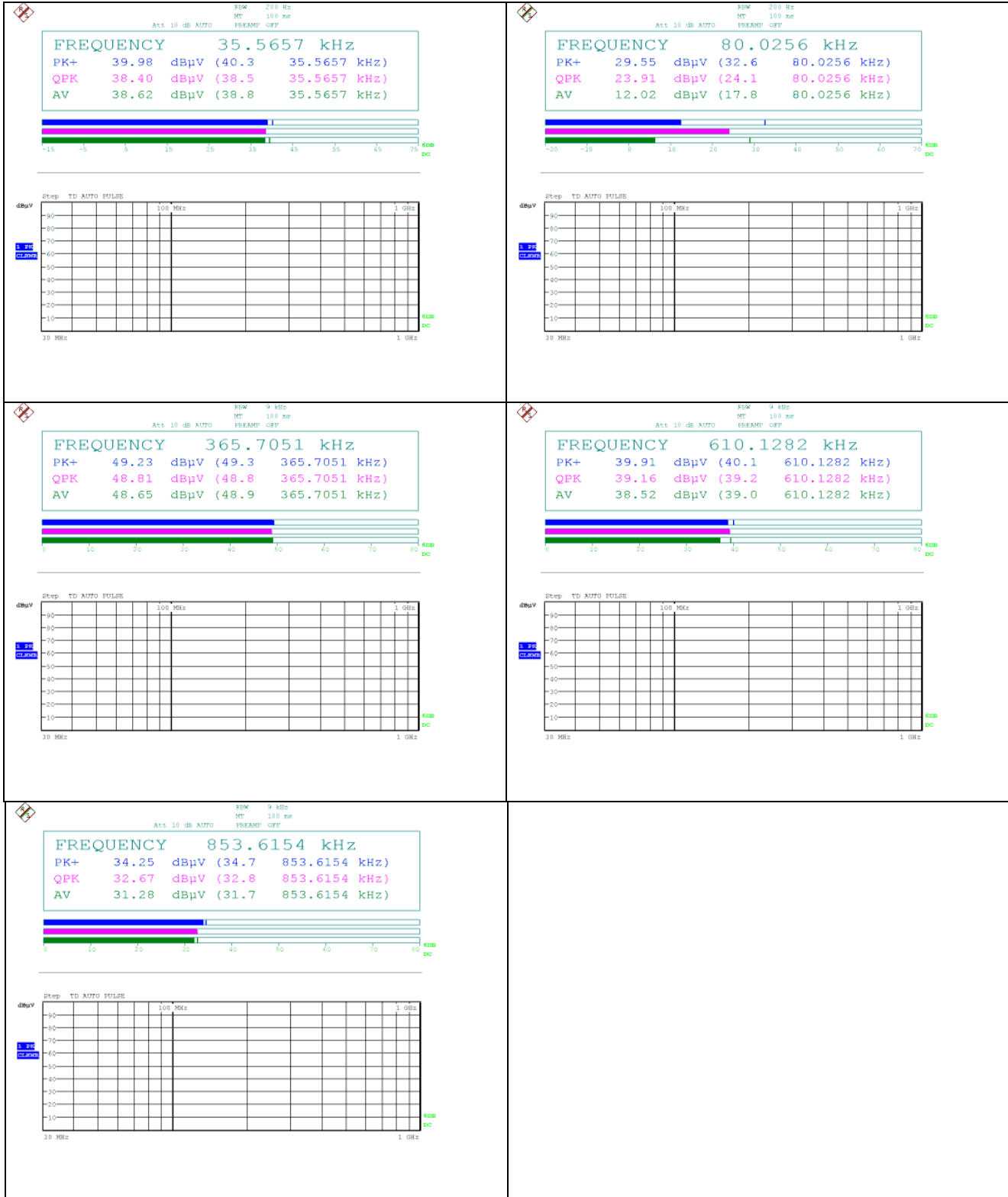

Above 30 MHz

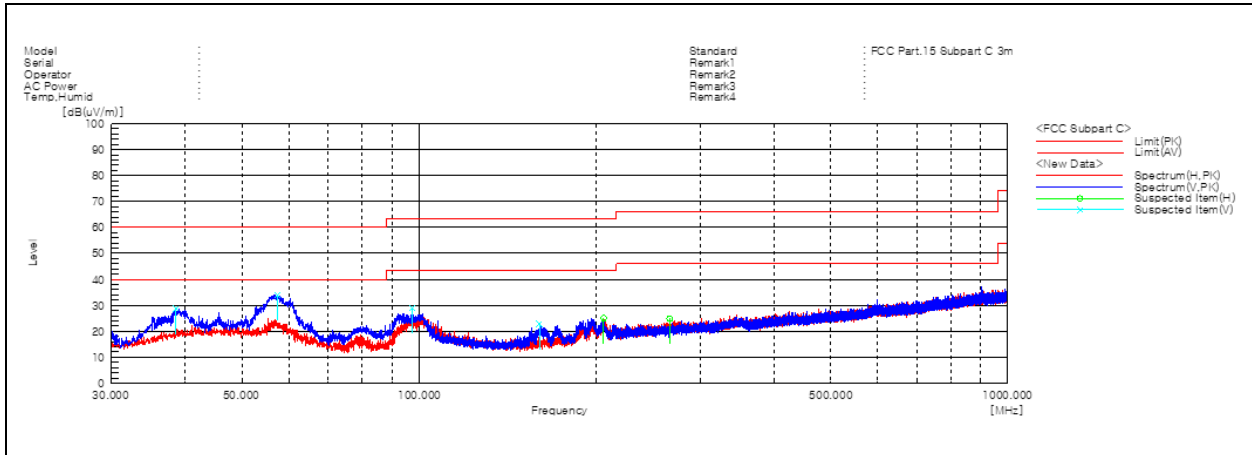

Remark;

- Traces shown in the plot were made by using a peak detector.

Ant. 6 (126.2 kHz ~ 129.2 kHz)

Below 30 MHz

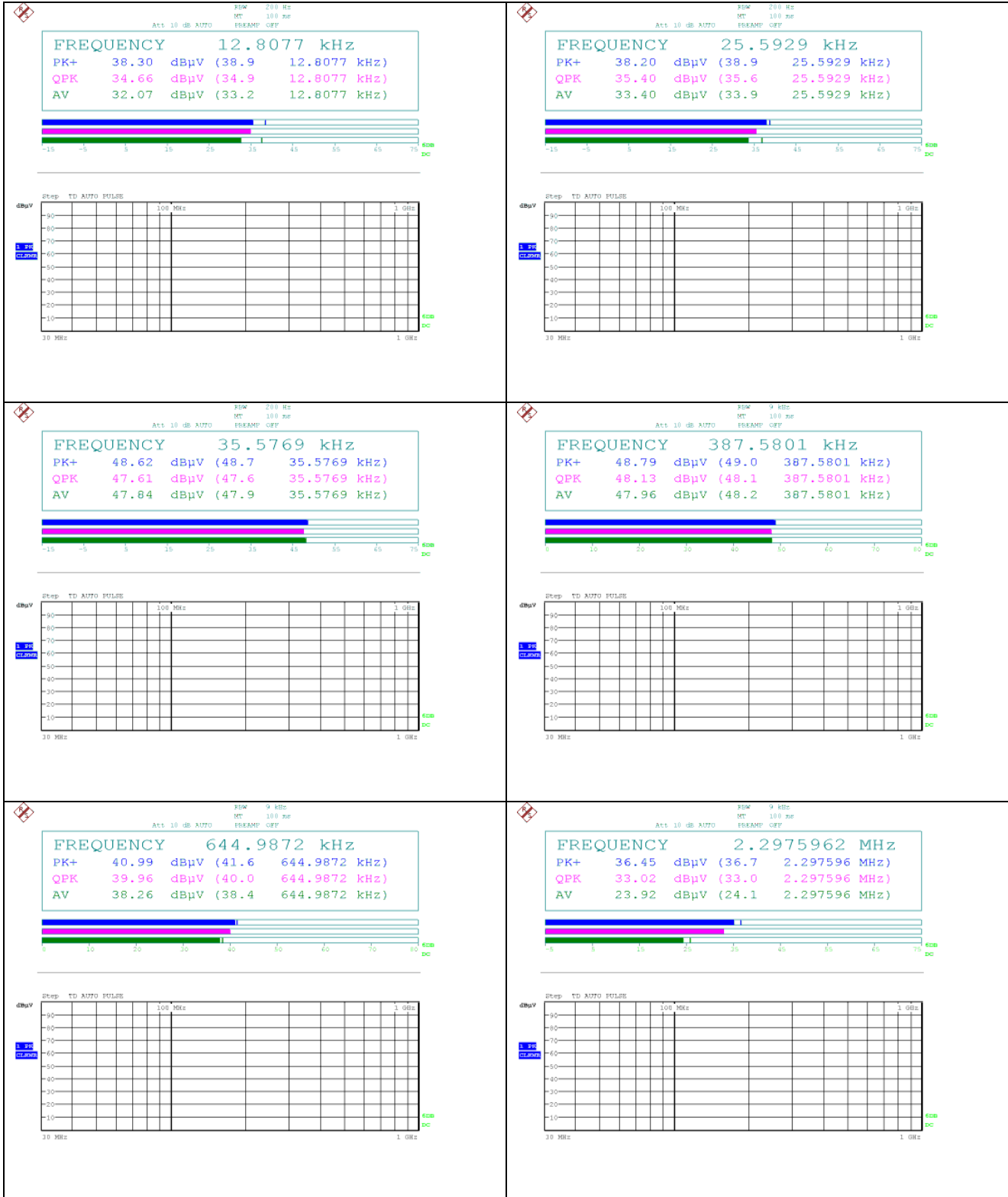

Above 30 MHz

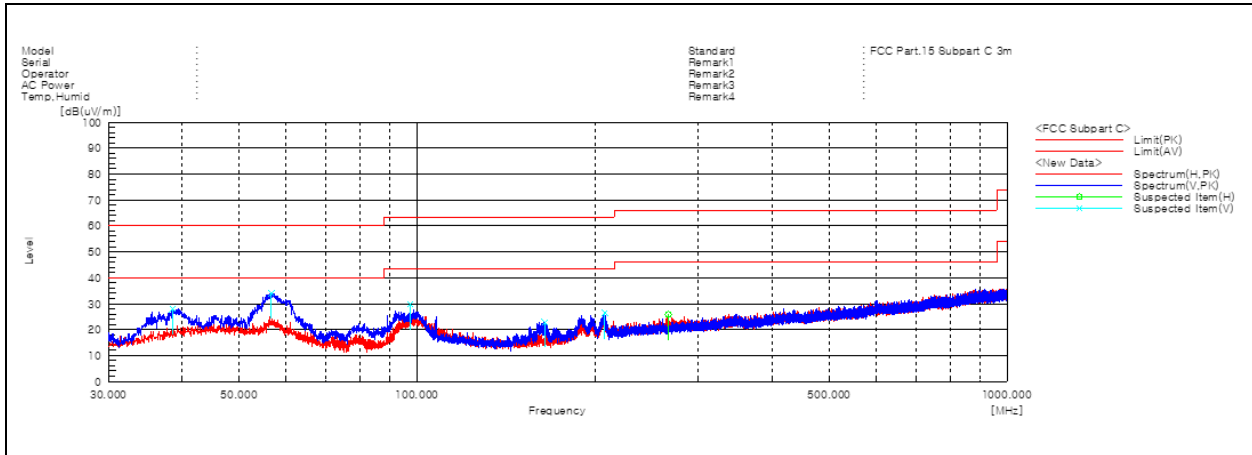

Remark;

- Traces shown in the plot were made by using a peak detector.

Test Condition: 9 W Operating mode with client device (1 % battery status of client device)

Ant. 1 (136.5 kHz ~ 139.5 kHz)

Below 30 MHz



Above 30 MHz

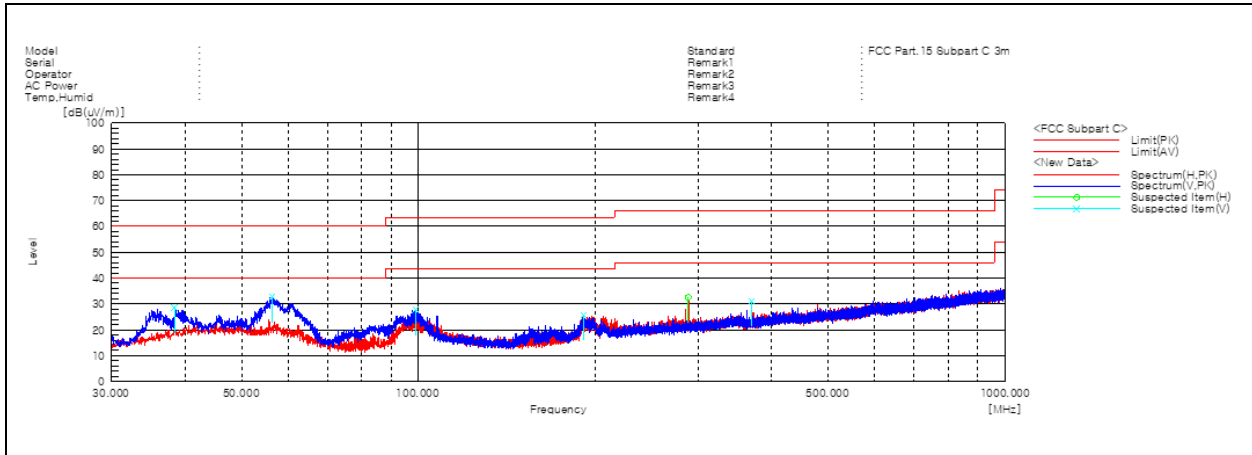

Remark;

- Traces shown in the plot were made by using a peak detector.

Ant. 6 (144.5 kHz ~ 147.5 kHz)

Below 30 MHz

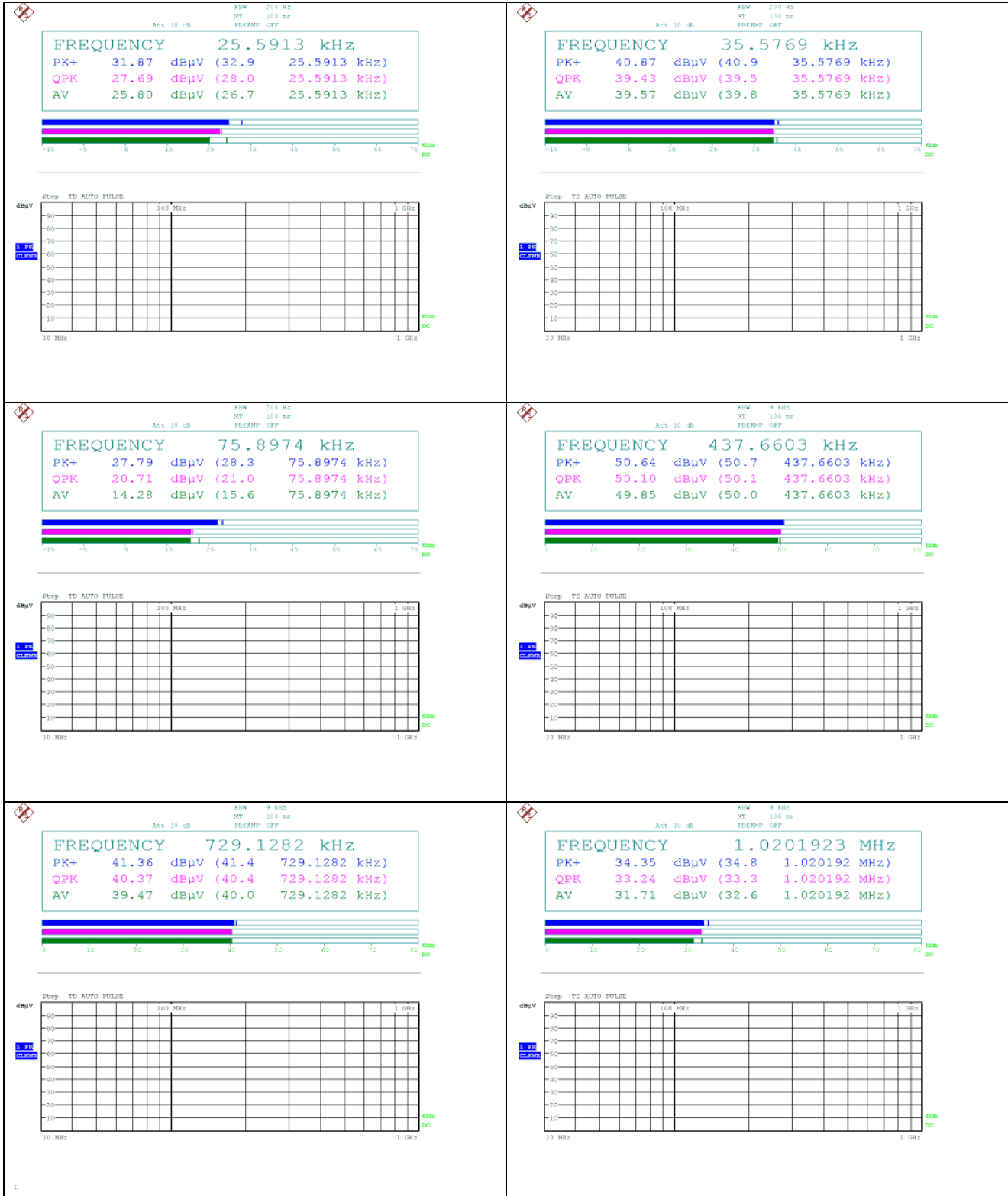

Above 30 MHz

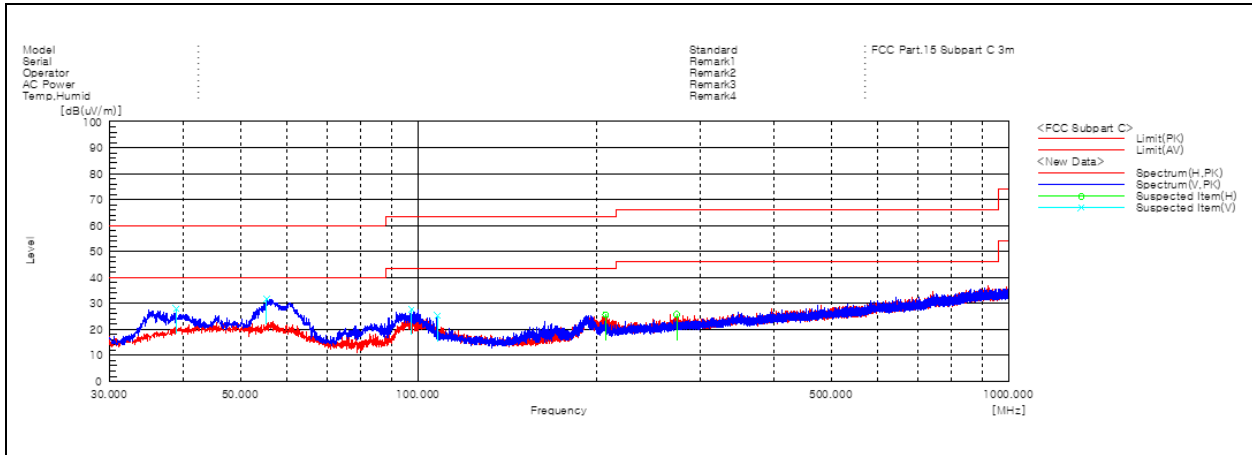

Remark;

- Traces shown in the plot were made by using a peak detector.

Test Condition: 2 W & 4.5W Operating mode with 3 client devices (1 % battery status of client device)

Ant. 1 (119 kHz ~ 122 kHz) & Ant. 6 (119 kHz ~ 122 kHz) & Ant. 7 (144.5 kHz ~ 147.5 kHz)

Below 30 MHz

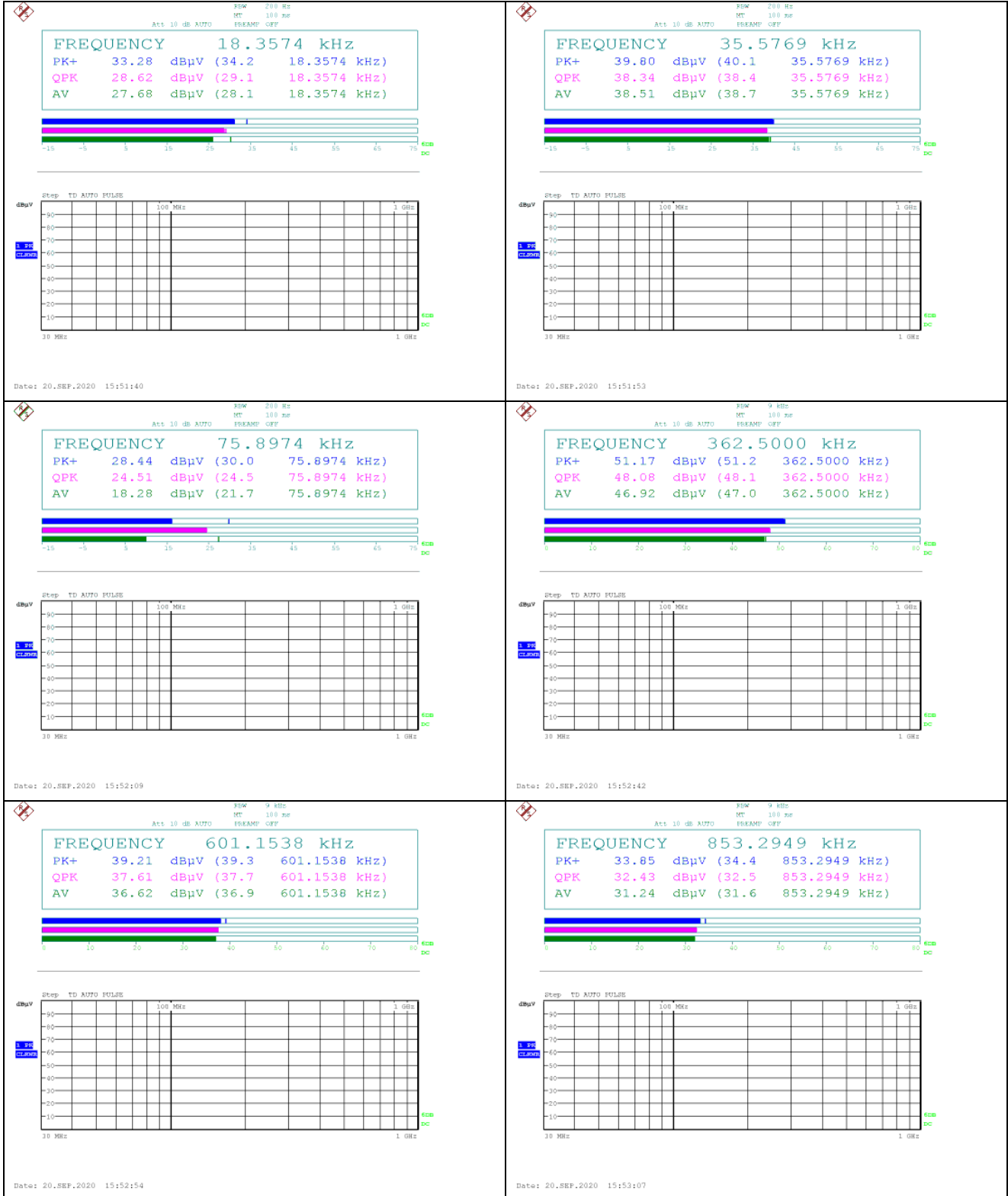

Above 30 MHz

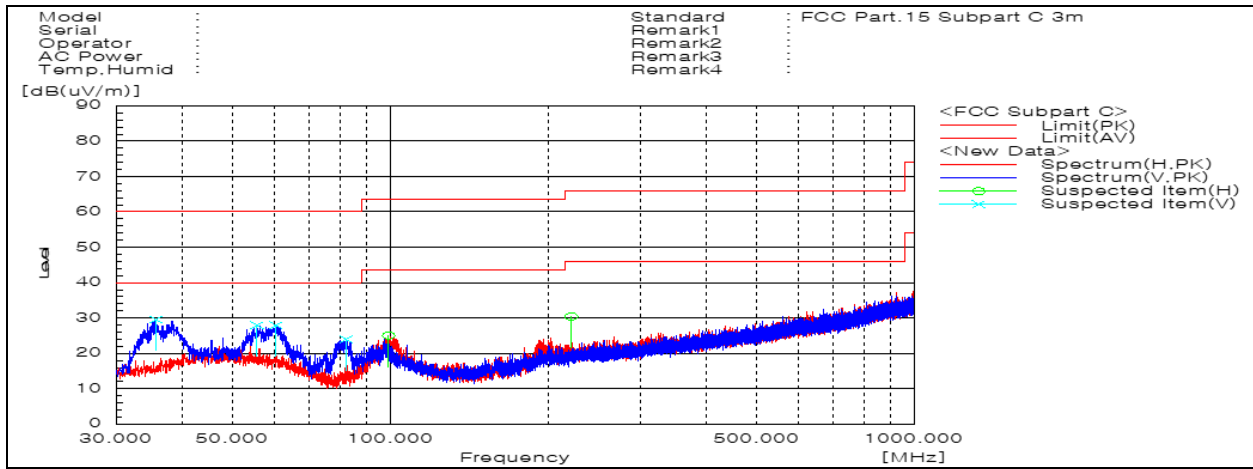

Remark;

- Traces shown in the plot were made by using a peak detector.

Ant. 1 (119 ㎐ ~ 122 ㎐) & Ant. 6 (126.2 ㎐ ~ 129.2 ㎐) & Ant. 7 (144.5 ㎐ ~ 147.5 ㎐)

Below 30 MHz



Above 30 MHz

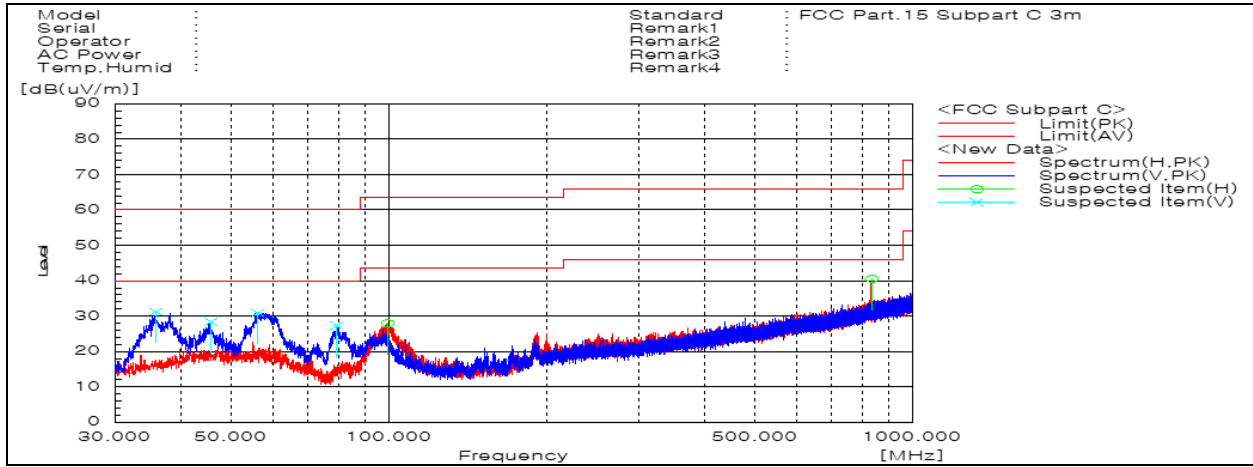

Remark;

- Traces shown in the plot were made by using a peak detector.

Ant. 1 (126.2 kHz ~ 129.2 kHz) & Ant. 6 (119 kHz ~ 122 kHz) & Ant. 7 (144.5 kHz ~ 147.5 kHz)

Below 30 MHz

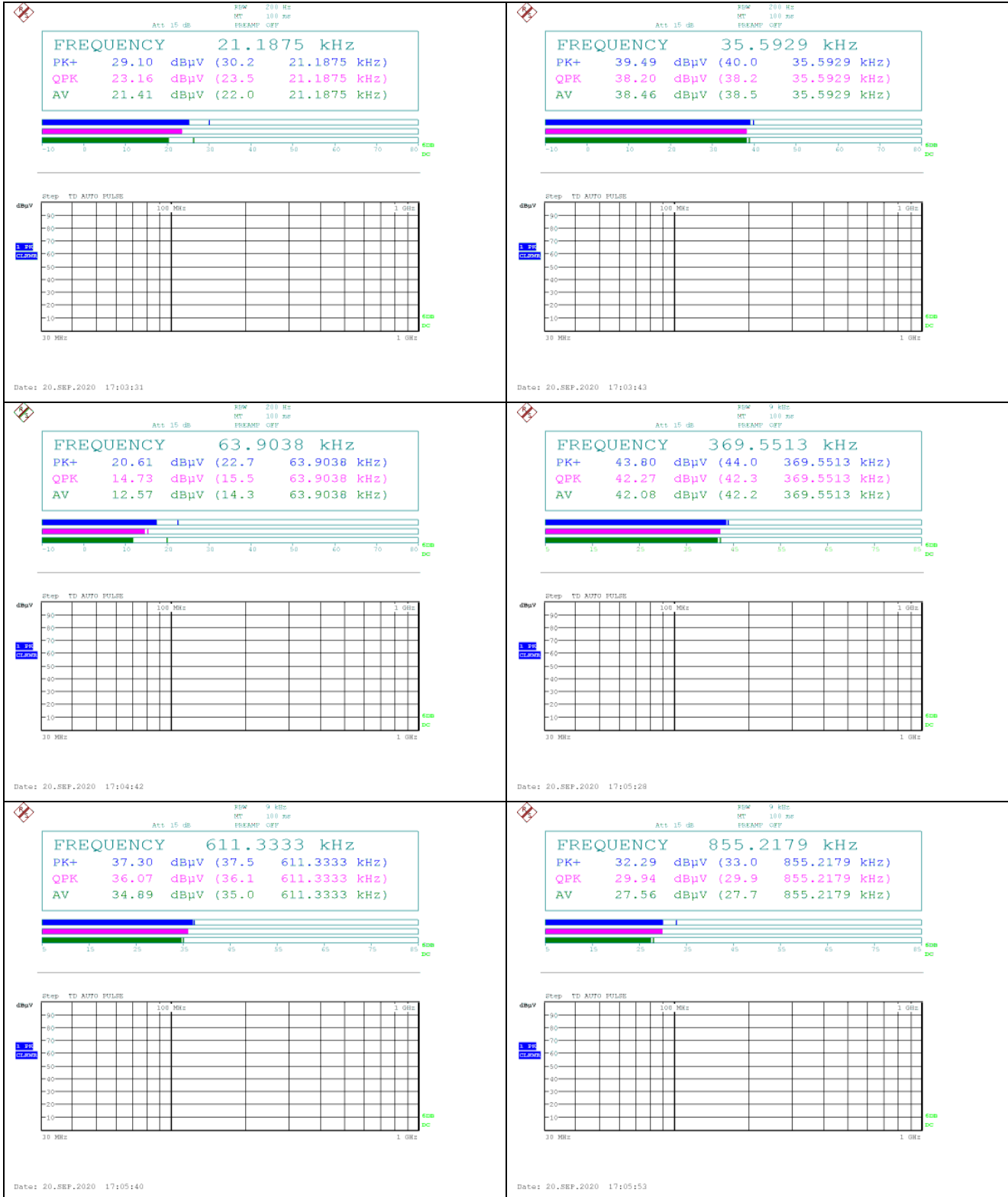

Above 30 MHz

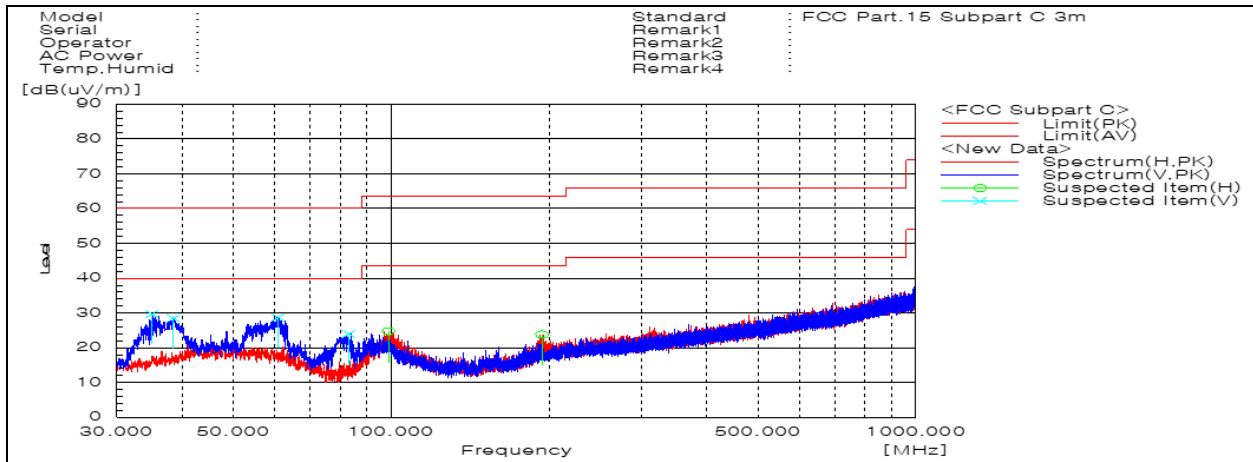

Remark;

- Traces shown in the plot were made by using a peak detector.

Ant. 1 (126.2 kHz ~ 129.2 kHz) & Ant. 6 (126.2 kHz ~ 129.2 kHz) & Ant. 7 (144.5 kHz ~ 147.5 kHz)

Below 30 MHz



Above 30 MHz

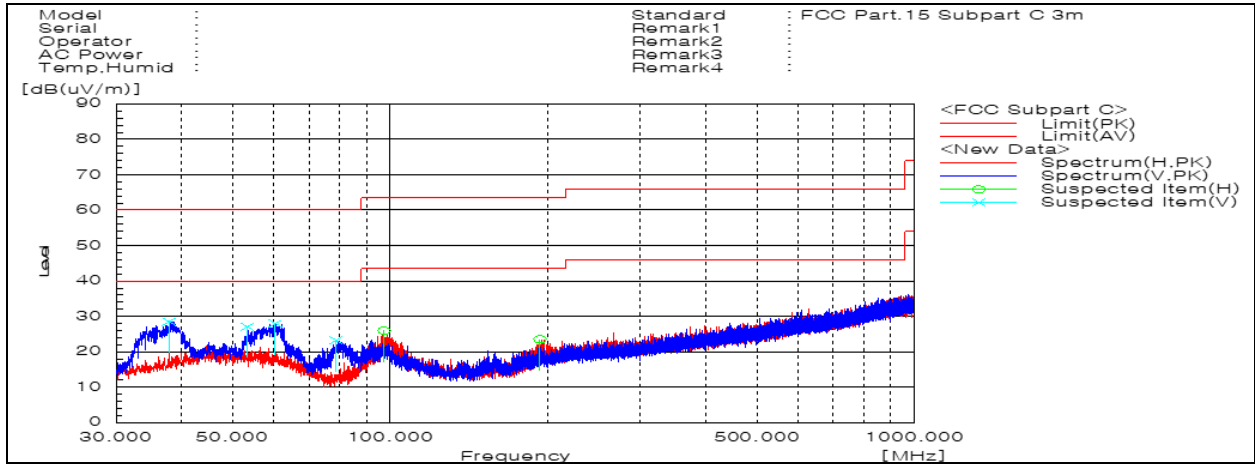

Remark;

- Traces shown in the plot were made by using a peak detector.

Test Condition: 2 W & 7.5W Operating mode with 3 client devices (1 % battery status of client device)

Ant. 1 (136.5 kHz ~ 139.5 kHz) & Ant. 6 (144.5 kHz ~ 147.5 kHz) & Ant. 7 (144.5 kHz ~ 147.5 kHz)

Below 30 MHz

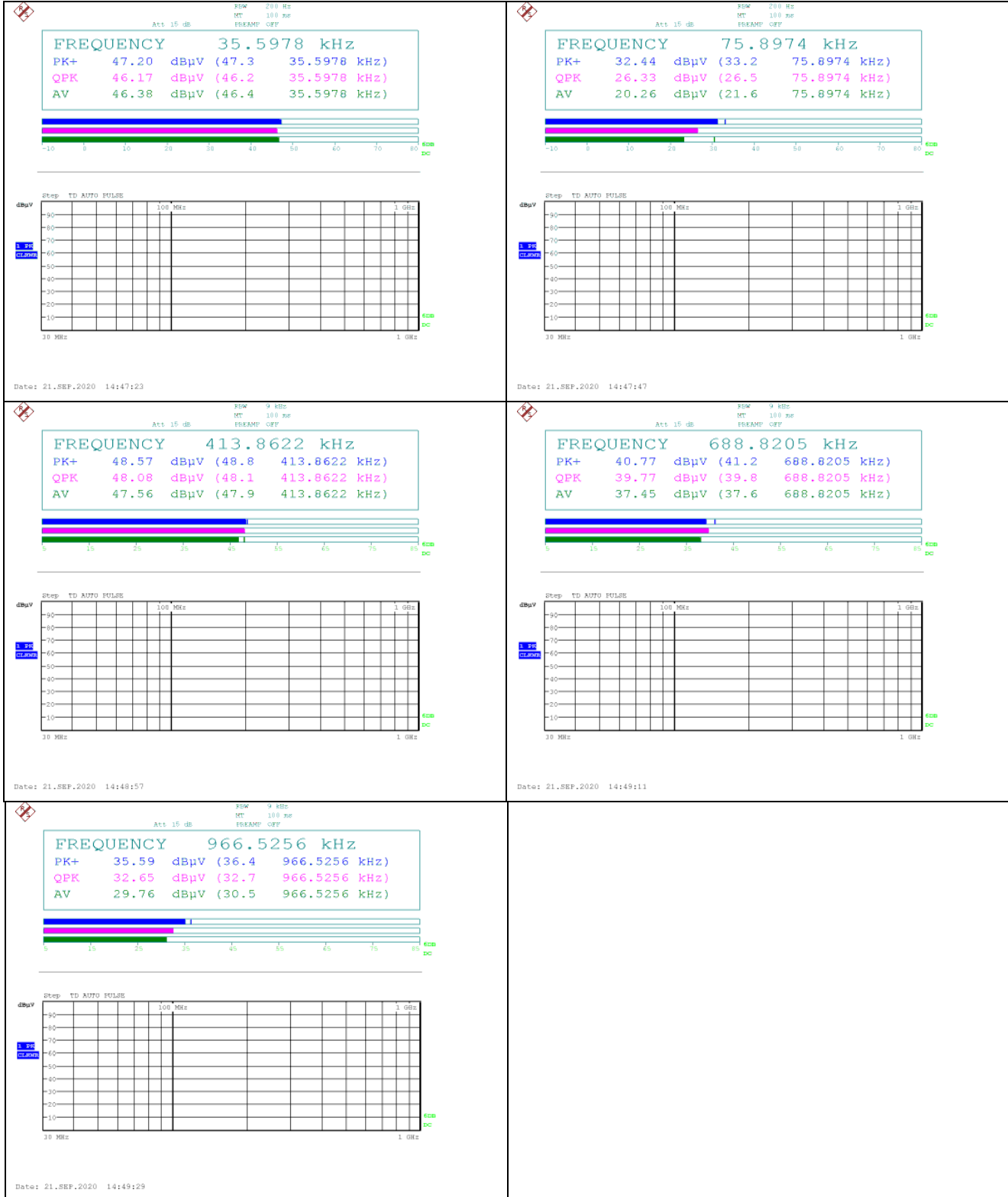

Above 30 MHz

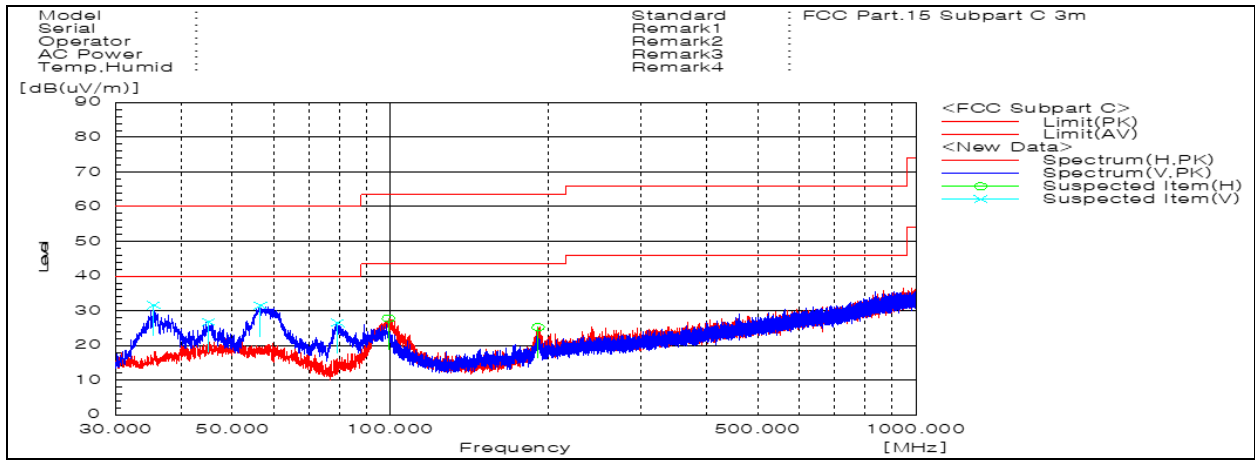

Remark;

- Traces shown in the plot were made by using a peak detector.

Ant. 1 (136.5 kHz ~ 139.5 kHz) & Ant. 6 (126.2 kHz ~ 129.2 kHz) & Ant. 7 (144.5 kHz ~ 147.5 kHz)

Below 30 MHz



Above 30 MHz

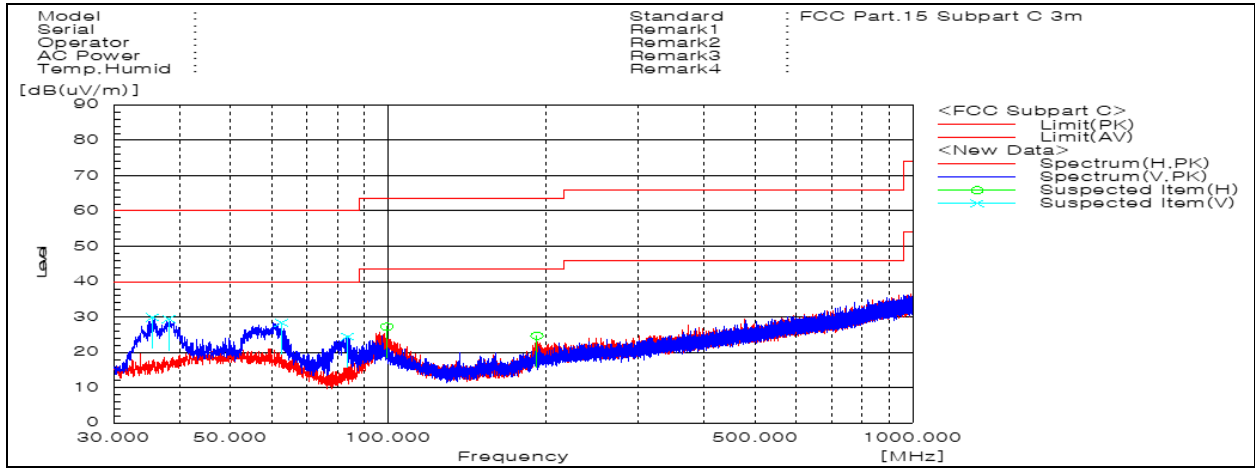

Remark;

- Traces shown in the plot were made by using a peak detector.

Ant. 1 (126.2 kHz ~ 129.2 kHz) & Ant. 6 (144.5 kHz ~ 147.5 kHz) & Ant. 7 (144.5 kHz ~ 147.5 kHz)

Below 30 MHz



Above 30 MHz

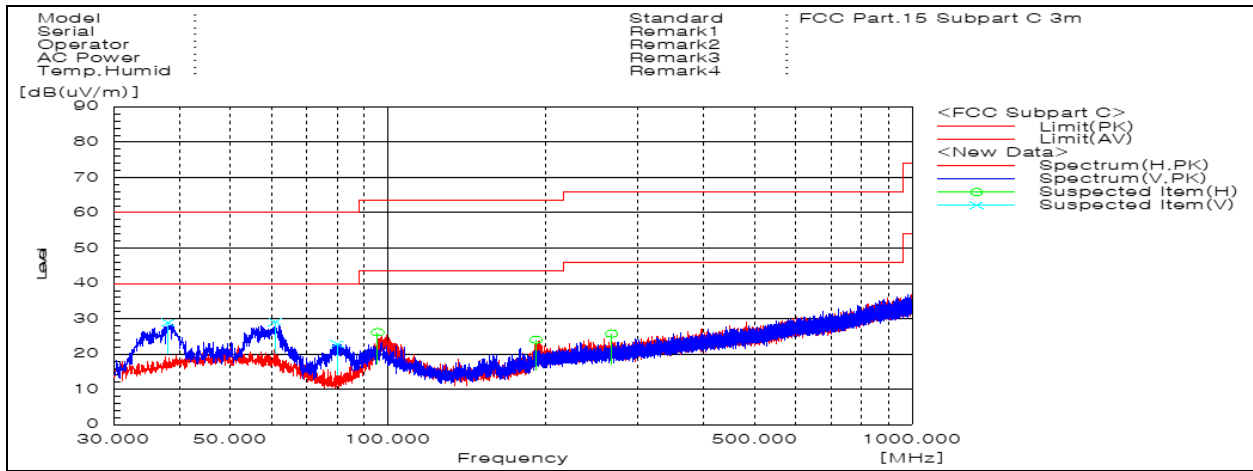

Remark;

- Traces shown in the plot were made by using a peak detector.

Ant. 1 (126.2 kHz ~ 129.2 kHz) & Ant. 6 (126.2 kHz ~ 129.2 kHz) & Ant. 7 (144.5 kHz ~ 147.5 kHz)

Below 30 MHz



Above 30 MHz

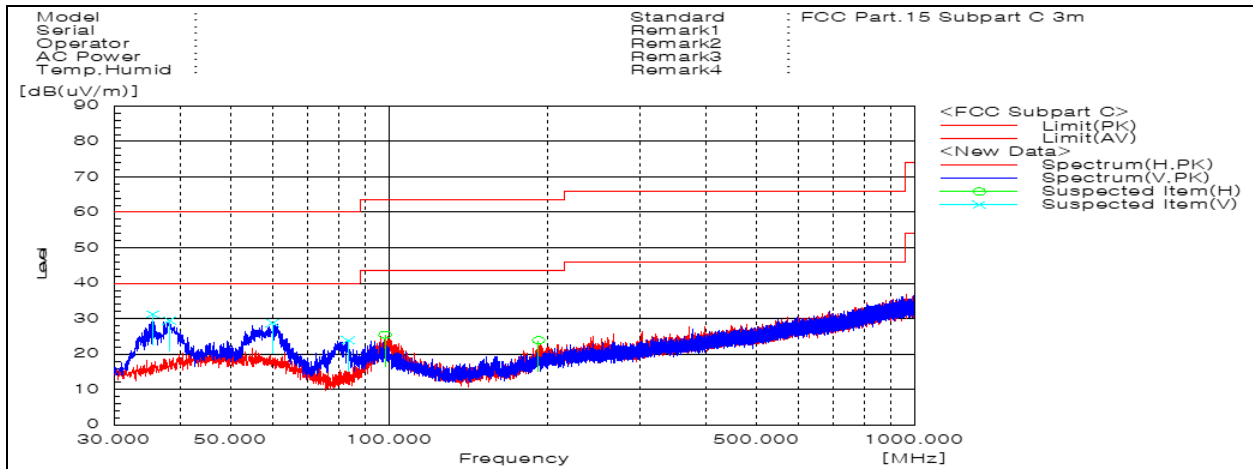

Remark;

- Traces shown in the plot were made by using a peak detector.

Test Condition: 2 W & 9W Operating mode with 3 client devices (1 % battery status of client device)

Ant. 1 (136.5 kHz ~ 139.5 kHz) & Ant. 6 (144.5 kHz ~ 147.5 kHz) & Ant. 7 (144.5 kHz ~ 147.5 kHz)

Below 30 MHz



Above 30 MHz

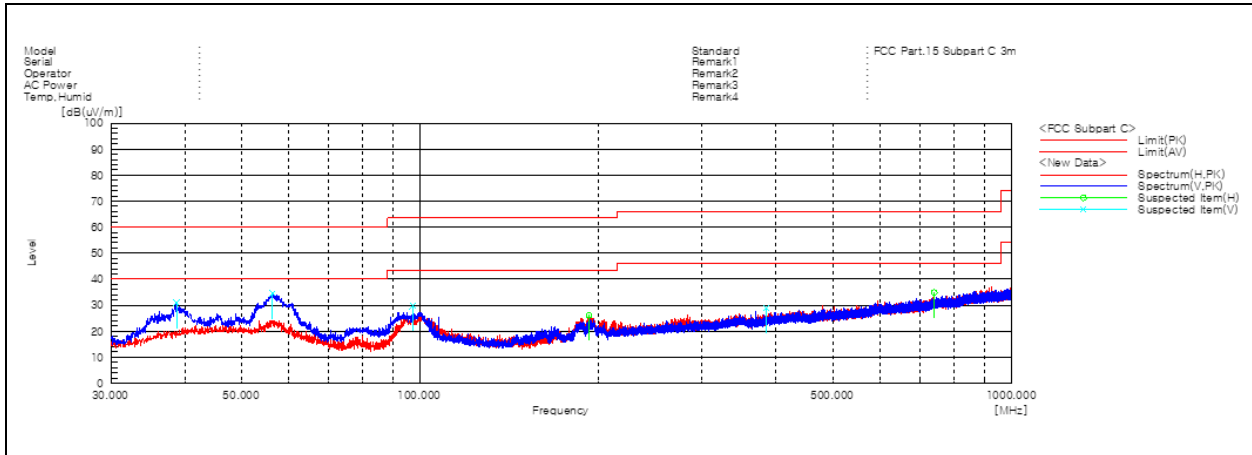

Remark;

- Traces shown in the plot were made by using a peak detector.

Test Condition: 2 W & 4.5W & 9W Operating mode with 3 client devices (1 % battery status of client device)

Ant. 1 (136.5 kHz ~ 139.5 kHz) & Ant. 6 (119 kHz ~ 122 kHz) & Ant. 7 (144.5 kHz ~ 147.5 kHz)

Below 30 MHz



Above 30 MHz

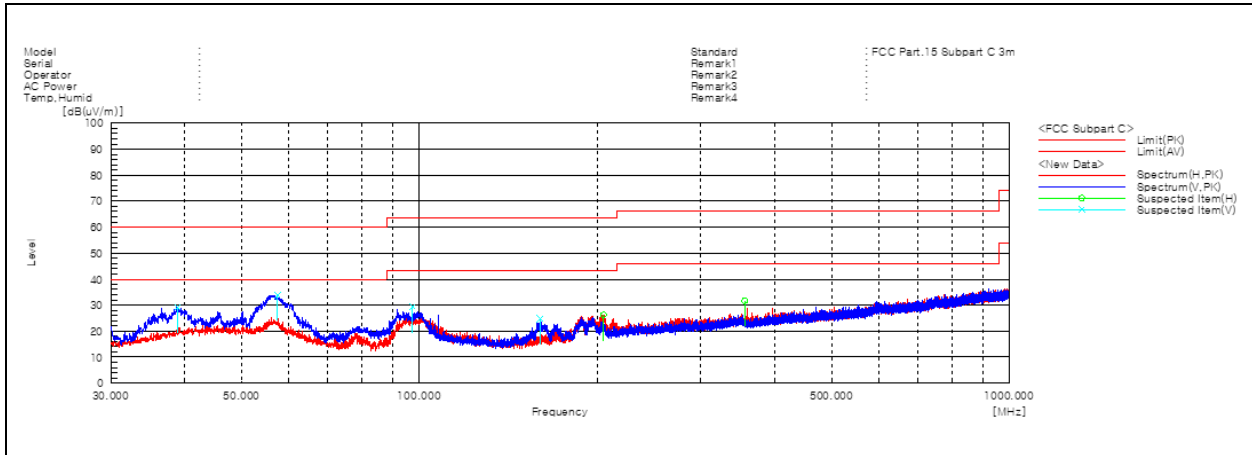

Remark;

- Traces shown in the plot were made by using a peak detector.

Ant. 1 (136.5 kHz ~ 139.5 kHz) & Ant. 6 (126.2 kHz ~ 129.2 kHz) & Ant. 7 (144.5 kHz ~ 147.5 kHz)

Below 30 MHz

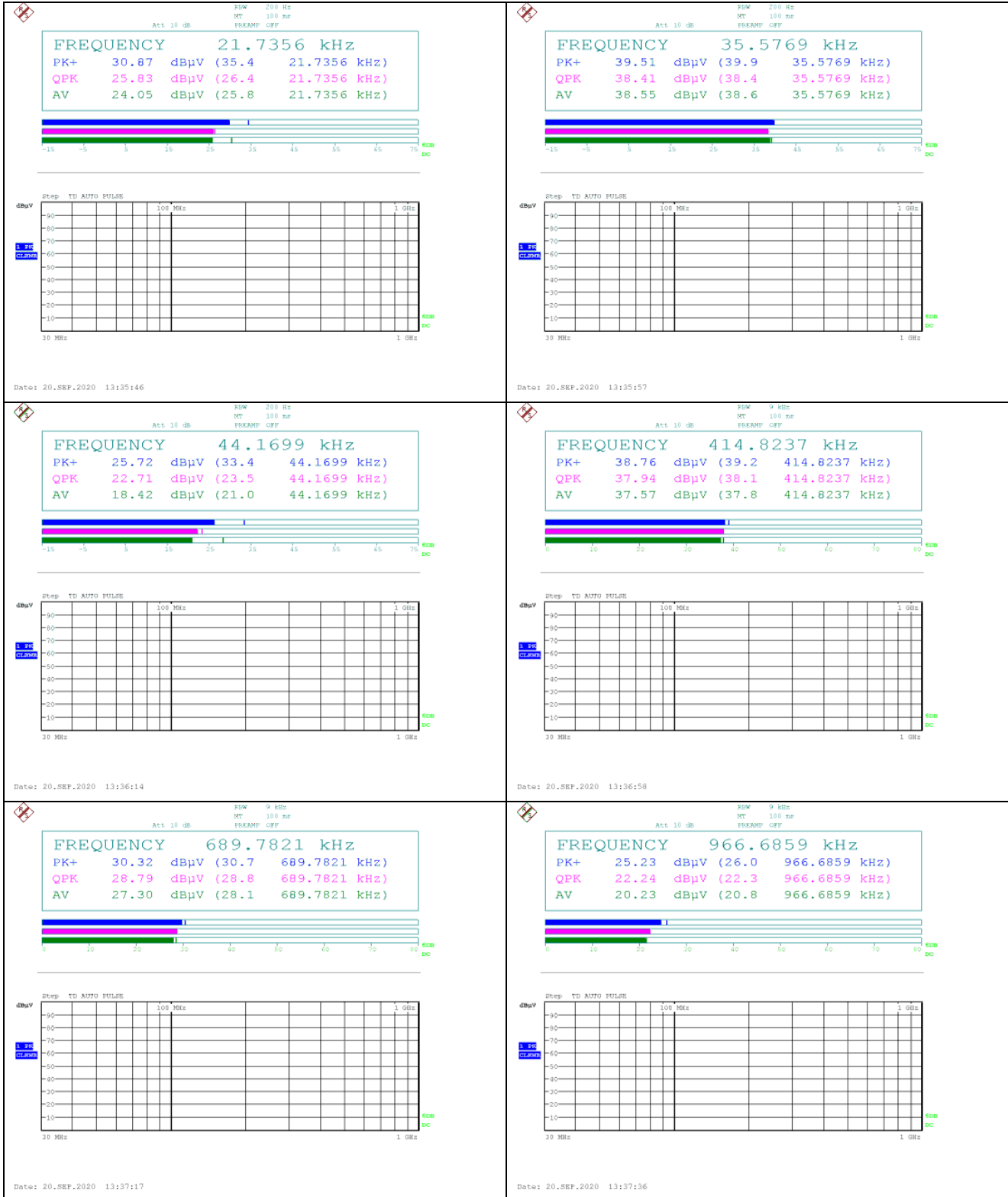

Above 30 MHz

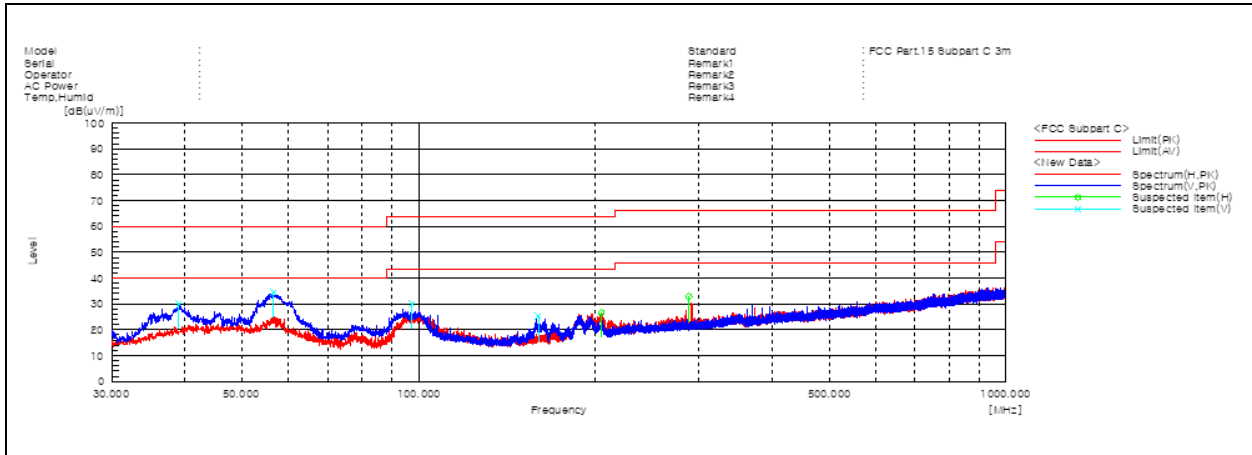

Remark;

- Traces shown in the plot were made by using a peak detector.

Ant. 1 (119 ㎐ ~ 122 ㎐) & Ant. 6 (144.5 ㎐ ~ 147.5 ㎐) & Ant. 7 (144.5 ㎐ ~ 147.5 ㎐)

Below 30 MHz



Above 30 MHz

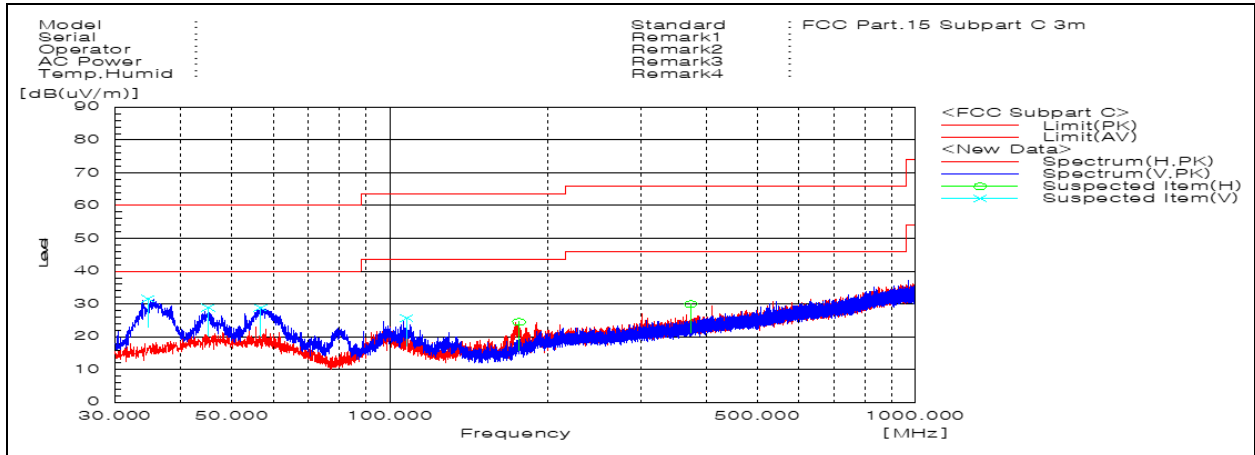

Remark;

- Traces shown in the plot were made by using a peak detector.

Ant. 1 (126.2 kHz ~ 129.2 kHz) & Ant. 6 (144.5 kHz ~ 147.5 kHz) & Ant. 7 (144.5 kHz ~ 147.5 kHz)

Below 30 MHz



Above 30 MHz

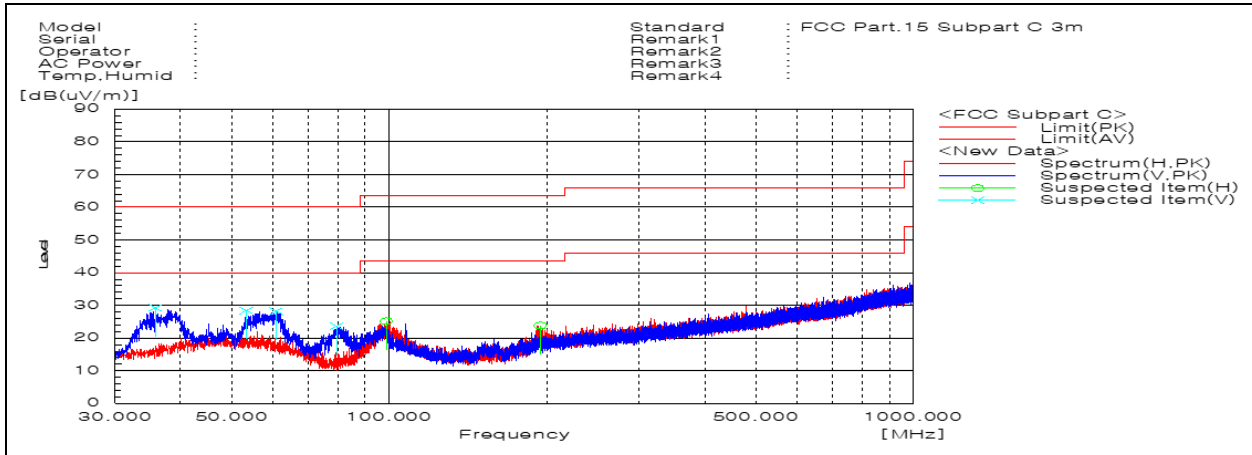

Remark;

- Traces shown in the plot were made by using a peak detector.

Test Condition: Ping mode with client device (Standby mode)

Ant. All (136.5 kHz ~ 139.5 kHz & 144.5 kHz ~ 147.5 kHz)

Below 30 MHz



Above 30 MHz

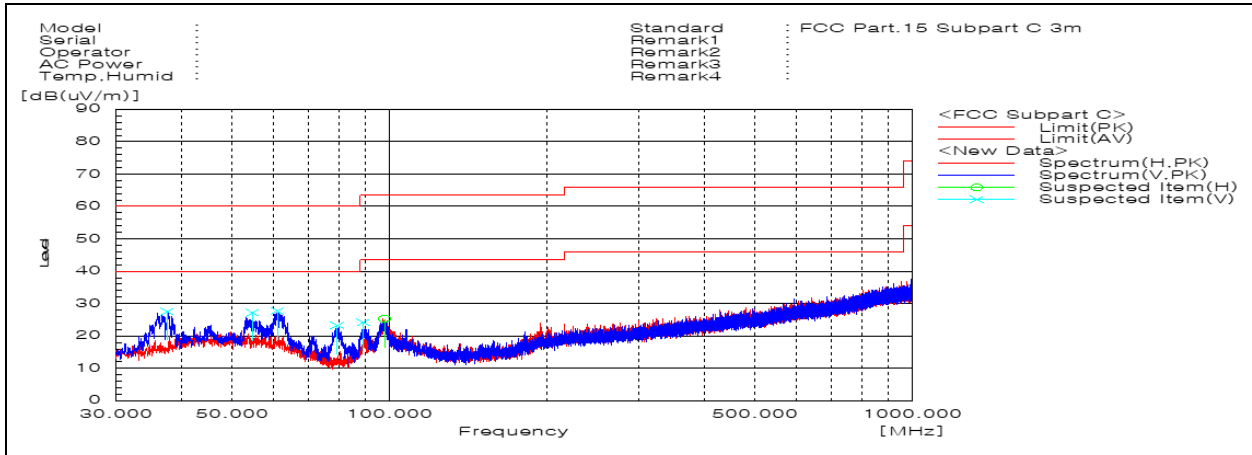

Remark;

- Traces shown in the plot were made by using a peak detector.

3. 20 dB Bandwidth

3.1. Test Setup

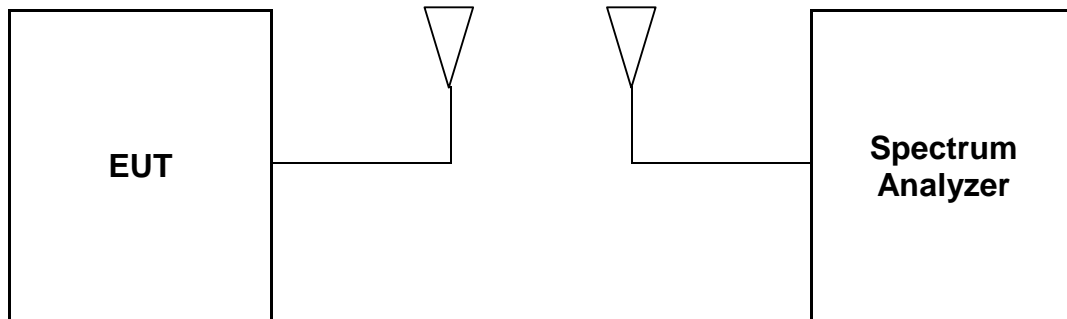

3.2. Limit

None; for reporting purposed only

3.3. Test Procedure

- a. Span = set to capture all products of the modulation process, including the emission skirts.
 RBW = 200 Hz, VBW = 200 Hz, Sweep = auto, Detector = peak, Trace = max hold.
- b. The marker-to-peak function to set the mark to the peak of the emission. Use the marker-delta function to measure 20 dB down one side of the emission. Reset the function, and move the marker to the other side of the emission, until it is (as close as possible to) even with the reference marker level. The marker-delta reading at this point is 20 dB bandwidth of the emission.

3.4. Test Result

Ambient temperature : (23 ± 1) °C
 Relative humidity : 47 % R.H.

Test Condition: 2 W Operating mode with client device (1 % battery status of client device)

Frequency (kHz)	Antenna	EUT Status	20 dB Bandwidth (kHz)	Limit
136.5 ~ 139.5	7	With client device (1 % battery status of client device)	0.550	Reporting proposed only

Test Condition: 4.5 W Operating mode with client device (1 % battery status of client device)

Frequency (kHz)	Antenna	EUT Status	20 dB Bandwidth (kHz)	Limit
119 ~ 122	1	With client device (1 % battery status of client device)	0.520	Reporting proposed only
126.2 ~ 129.2	1		0.521	
119 ~ 122	6		0.521	
126.2 ~ 129.2	6		0.521	

Test Condition: 9 W Operating mode with client device (1 % battery status of client device)

Frequency (kHz)	Antenna	EUT Status	20 dB Bandwidth (kHz)	Limit
136.5 ~ 139.5	1	With client device (1 % battery status of client device)	0.545	Reporting proposed only
144.5 ~ 147.5	6		0.510	

Test Condition: 2 W & 4.5W Operating mode with 3 client devices (1 % battery status of client device)

Frequency (kHz)	Antenna	EUT Status	20 dB Bandwidth (kHz)	Limit
Ant. 1: 119 ~ 122 & Ant. 6: 119 ~ 122 & Ant. 7: 144.5 ~ 147.5	1	With client device (1 % battery status of client device)	0.513	Reporting proposed only
	6		0.508	
	7		0.546	
Ant. 1: 119 ~ 122 & Ant. 6: 126.2 ~ 129.2 & Ant. 7: 144.5 ~ 147.5	1		0.513	
	6		0.518	
	7		0.528	
Ant. 1: 126.2 ~ 129.2 & Ant. 6: 119 ~ 122 & Ant. 7: 144.5 ~ 147.5	1		0.515	
	6		0.517	
	7		0.554	
Ant. 1: 126.2 ~ 129.2 & Ant. 6: 126.2 ~ 129.2 & Ant. 7: 144.5 ~ 147.5	1		0.515	
	6		0.518	
	7		0.554	

Test Condition: 2 W & 7.5W Operating mode with 3 client devices (1 % battery status of client device)

Frequency (kHz)	Antenna	EUT Status	20 dB Bandwidth (kHz)	Limit
Ant. 1: 136.5 ~ 139.5 & Ant. 6: 144.5 ~ 147.5 & Ant. 7: 144.5 ~ 147.5	1	With client device (1 % battery status of client device)	0.534	Reporting proposed only
	6		0.515	
	7		0.561	
Ant. 1: 136.5 ~ 139.5 & Ant. 6: 126.2 ~ 129.2 & Ant. 7: 144.5 ~ 147.5	1		0.518	
	6		0.515	
	7		0.559	
Ant. 1: 126.2 ~ 129.2 & Ant. 6: 144.5 ~ 147.5 & Ant. 7: 144.5 ~ 147.5	1		0.515	
	6		0.515	
	7		0.548	
Ant. 1: 126.2 ~ 129.2 & Ant. 6: 126.2 ~ 129.2 & Ant. 7: 144.5 ~ 147.5	1		0.515	
	6		0.518	
	7		0.517	

Test Condition: 2 W & 9W Operating mode with 3 client devices (1 % battery status of client device)

Frequency (kHz)	Antenna	EUT Status	20 dB Bandwidth (kHz)	Limit
Ant. 1: 136.5 ~ 139.5 & Ant. 6: 144.5 ~ 147.5 & Ant. 7: 144.5 ~ 147.5	1	With client device (1 % battery status of client device)	0.528	Reporting proposed only
	6		0.519	
	7		0.552	

Test Condition: 2 W & 4.5W & 9W Operating mode with 3 client devices (1 % battery status of client device)

Frequency (kHz)	Antenna	EUT Status	20 dB Bandwidth (kHz)	Limit
Ant. 1: 136.5 ~ 139.5 & Ant. 6: 119 ~ 122 & Ant. 7: 144.5 ~ 147.5	1	With client device (1 % battery status of client device)	0.530	Reporting proposed only
	6		0.508	
	7		0.559	
Ant. 1: 136.5 ~ 139.5 & Ant. 6: 126.2 ~ 129.2 & Ant. 7: 144.5 ~ 147.5	1		0.515	
	6		0.518	
	7		0.546	
Ant. 1: 119 ~ 122 & Ant. 6: 144.5 ~ 147.5 & Ant. 7: 144.5 ~ 147.5	1		0.513	
	6		0.515	
	7		0.543	
Ant. 1: 126.2 ~ 129.2 & Ant. 6: 144.5 ~ 147.5 & Ant. 7: 144.5 ~ 147.5	1		0.515	
	6		0.521	
	7		0.517	

Test Condition: Ping mode with client device (Standby mode)

Frequency (kHz)	Antenna	EUT Status	20 dB Bandwidth (kHz)	Limit
Ant. 1: 136.5 ~ 139.5 & Ant. 6: 144.5 ~ 147.5 & Ant. 7: 144.5 ~ 147.5	1	With client device (1 % battery status of client device)	0.519	Reporting proposed only
	6		0.515	
	7		0.521	

- Test plots

Test Condition: 2 W Operating mode with client device (1 % battery status of client device)

Ant. 7 (144.5 kHz ~ 147.5 kHz)

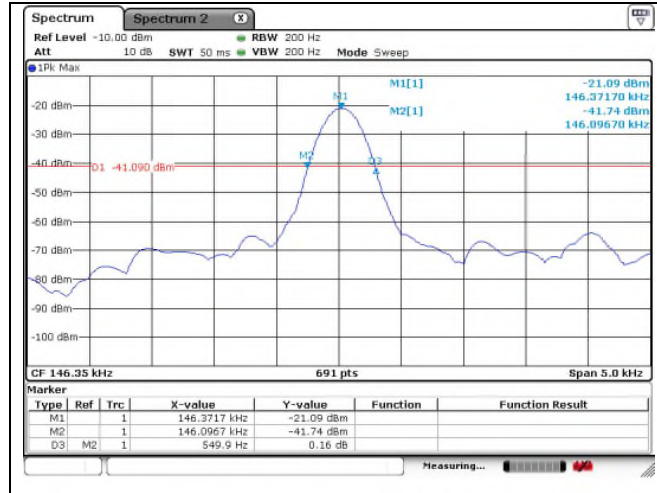

Test Condition: 4.5 W Operating mode with client device (1 % battery status of client device)

Ant. 1 (119 kHz ~ 122 kHz)

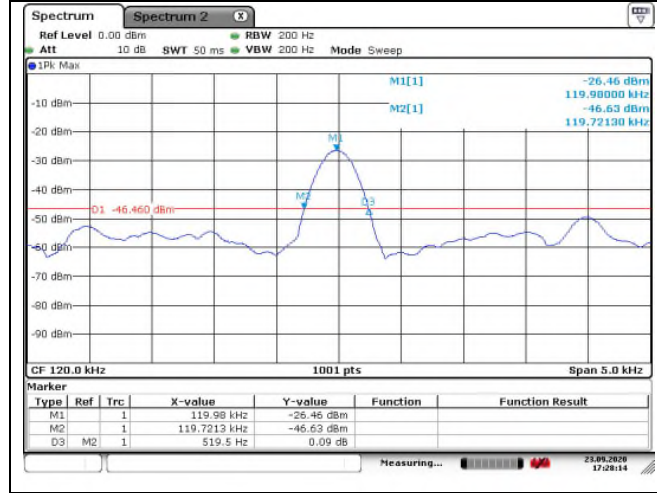

Ant. 1 (126.2 kHz ~ 129.2 kHz)

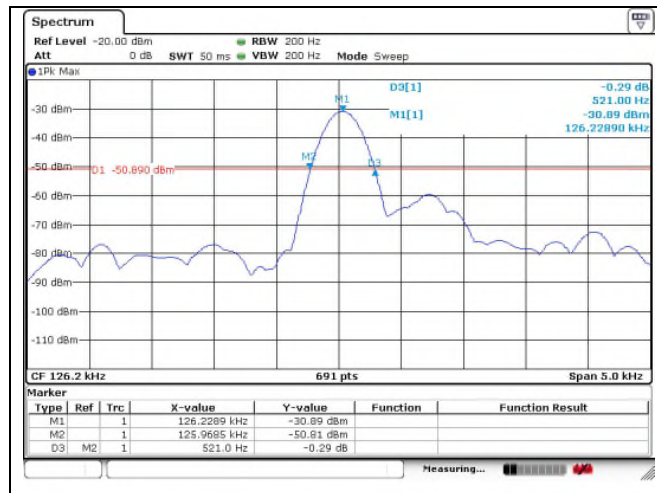

Ant. 6 (119 kHz ~ 122 kHz)

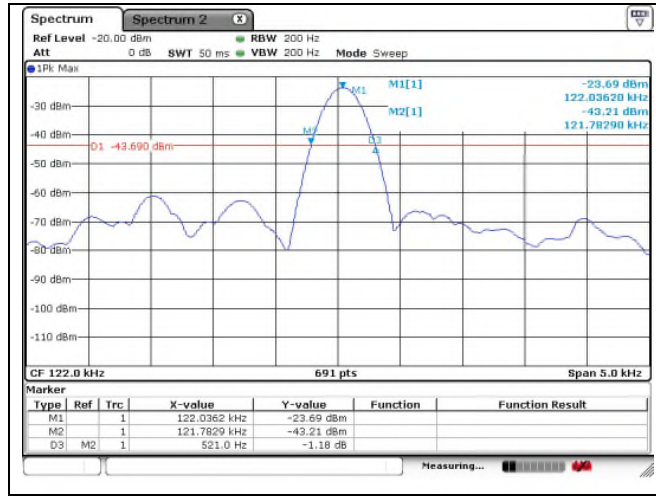

Ant. 6 (126.2 kHz ~ 129.2 kHz)

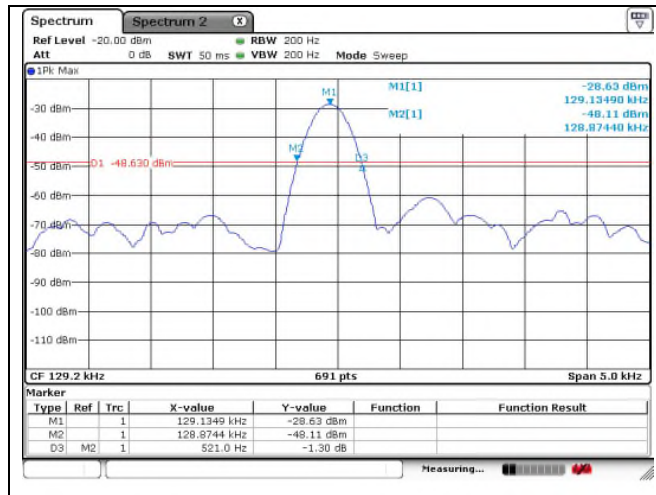

Test Condition: 9 W Operating mode with client device (1 % battery status of client device)

Ant. 1 (136.5 kHz ~ 139.5 kHz)

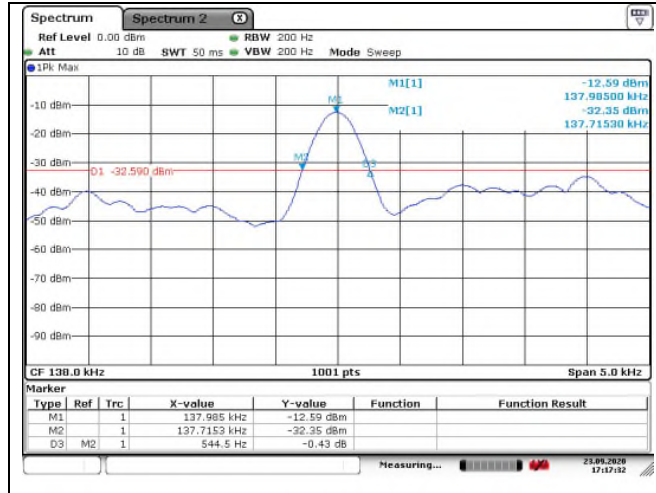

Ant. 6 (144.5 kHz ~ 147.5 kHz)

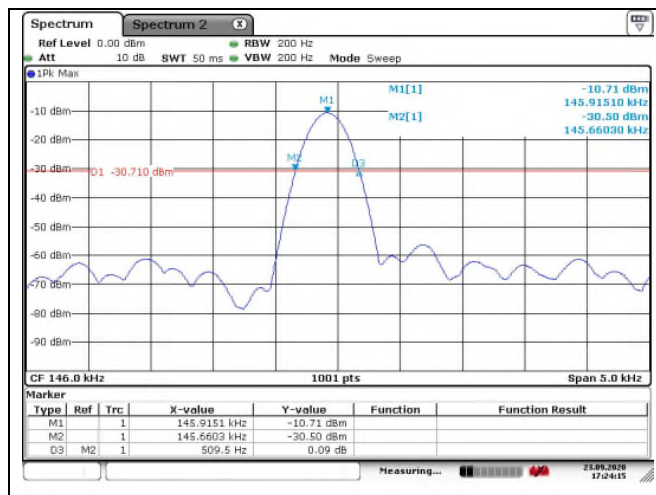

Test Condition: 2 W & 4.5W Operating mode with 3 client devices (1 % battery status of client device)

Ant. 1 (119 kHz ~ 122 kHz) & Ant. 6 (119 kHz ~ 122 kHz) & Ant. 7 (144.5 kHz ~ 147.5 kHz)

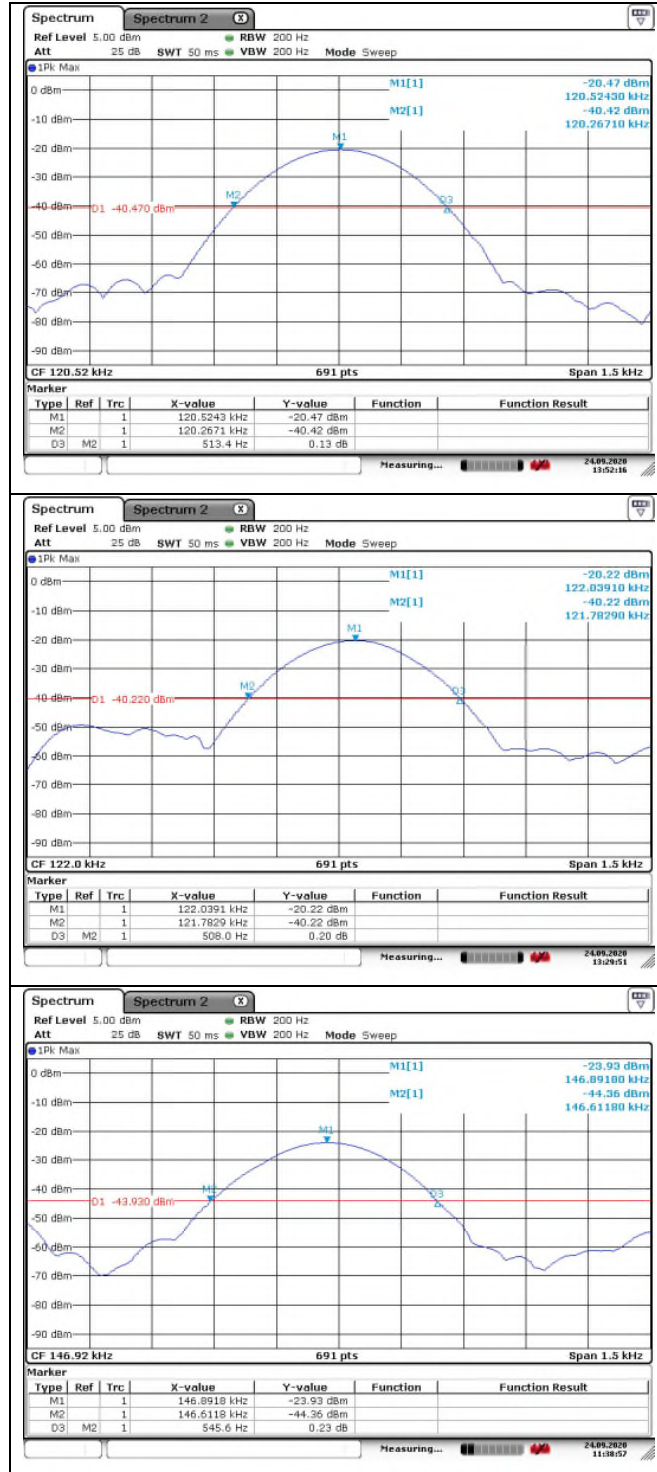

Ant. 1 (119 kHz ~ 122 kHz) & Ant. 6 (126.2 kHz ~ 129.2 kHz) & Ant. 7 (144.5 kHz ~ 147.5 kHz)

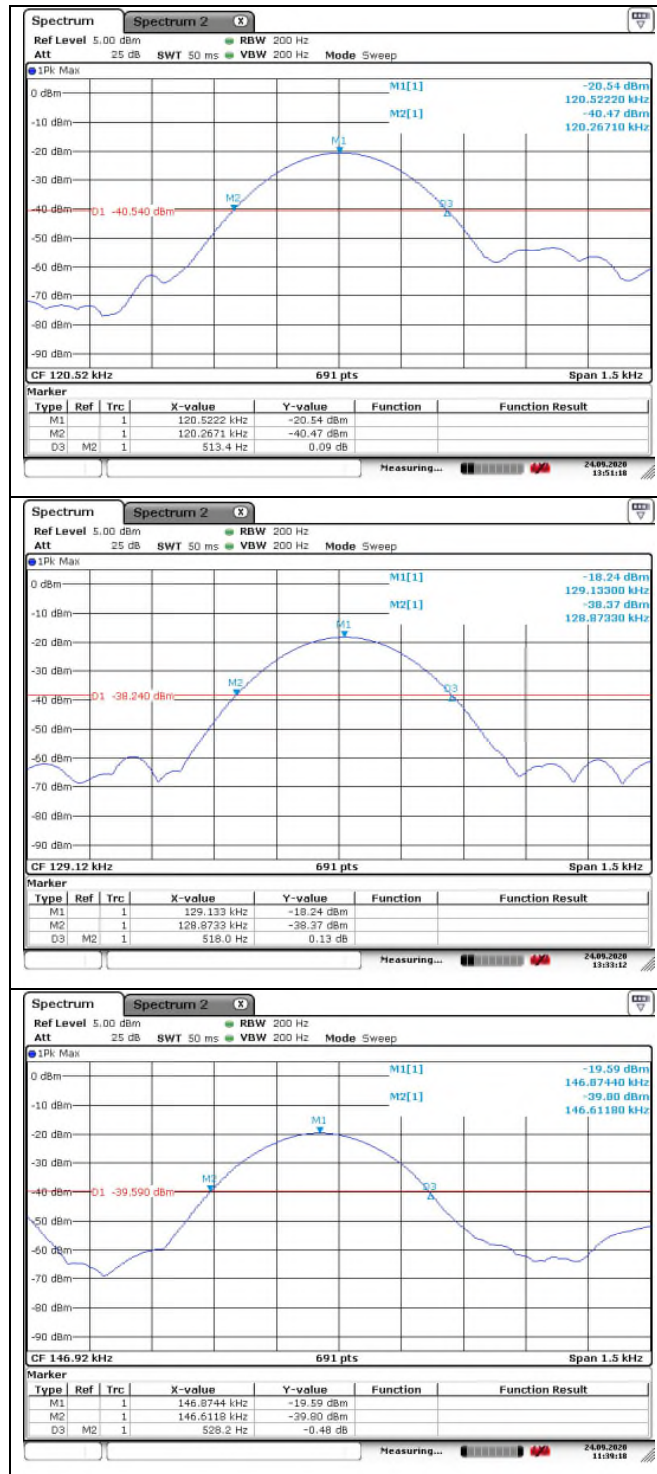

Ant. 1 (126.2 kHz ~ 129.2 kHz) & Ant. 6 (119 kHz ~ 122 kHz) & Ant. 7 (144.5 kHz ~ 147.5 kHz)

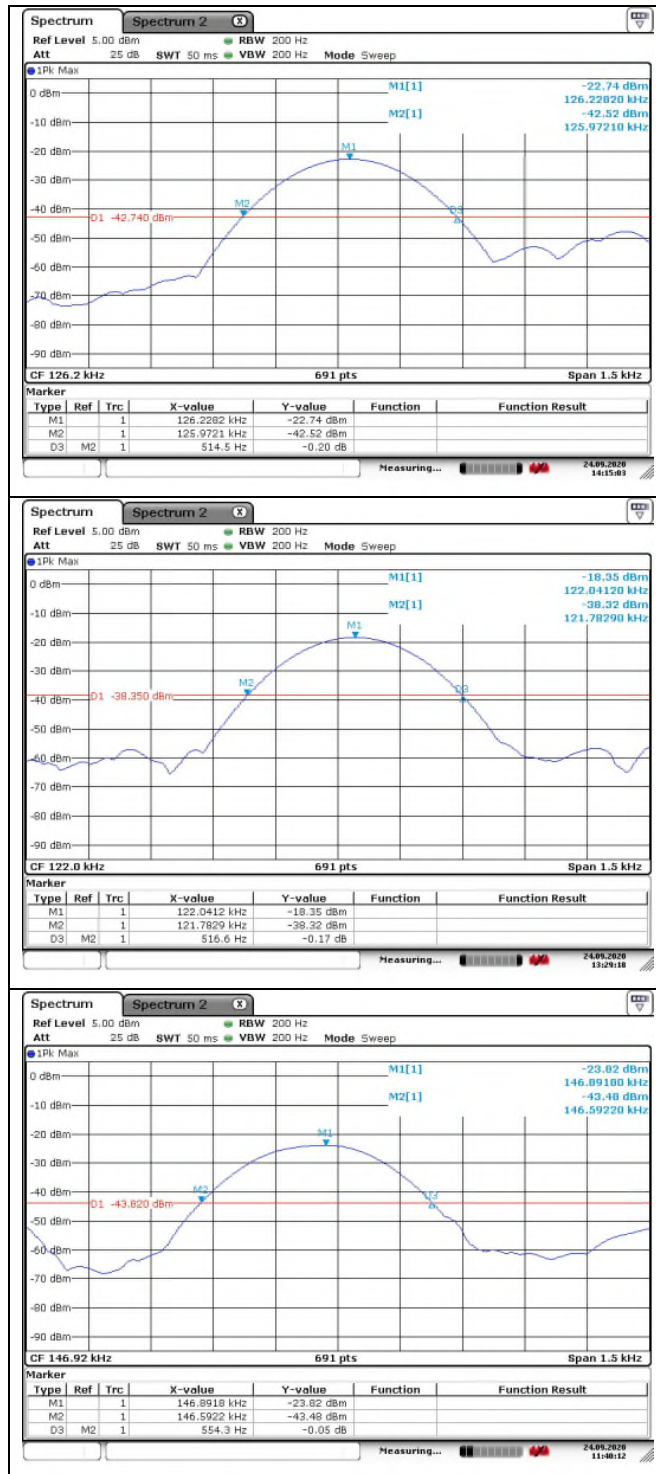

Ant. 1 (126.2 kHz ~ 129.2 kHz) & Ant. 6 (126.2 kHz ~ 129.2 kHz) & Ant. 7 (144.5 kHz ~ 147.5 kHz)

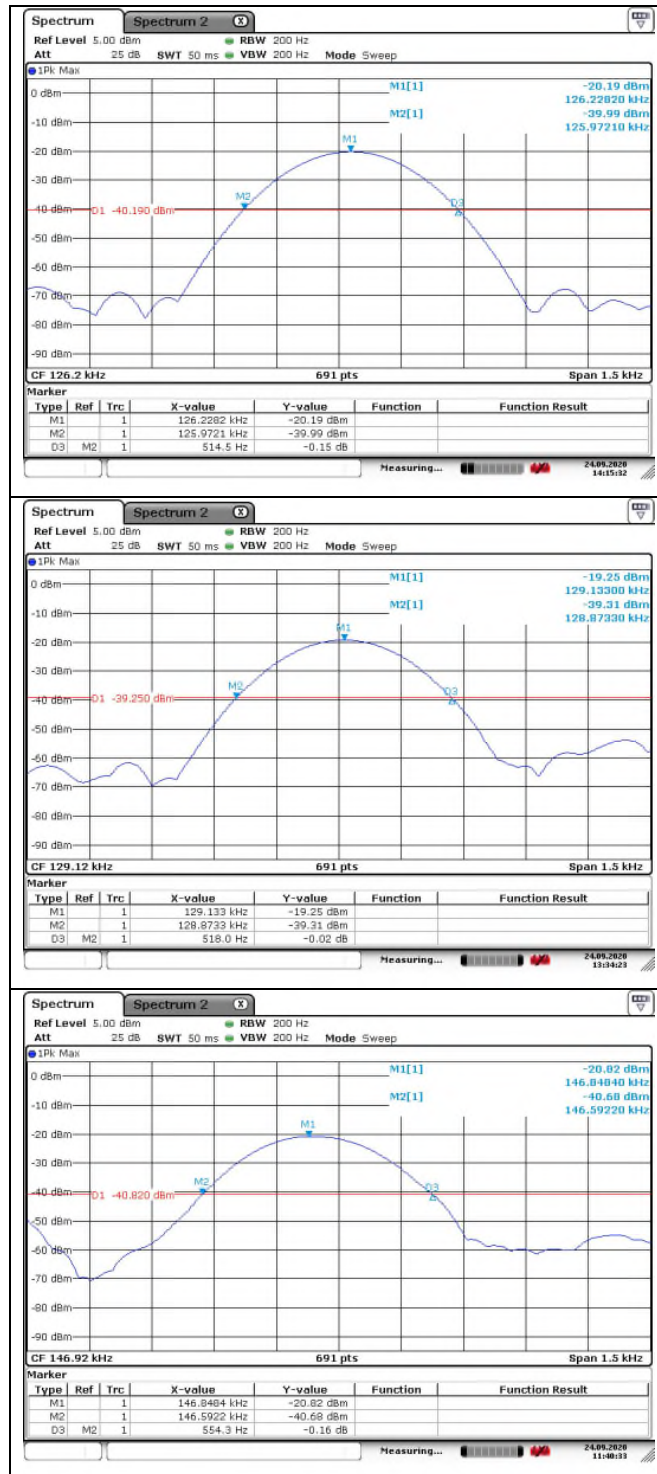

Test Condition: 2 W & 7.5W Operating mode with 3 client devices (1 % battery status of client device)

Ant. 1 (136.5 kHz ~ 139.5 kHz) & Ant. 6 (144.5 kHz ~ 147.5 kHz) & Ant. 7 (144.5 kHz ~ 147.5 kHz)



Ant. 1 (136.5 kHz ~ 139.5 kHz) & Ant. 6 (126.2 kHz ~ 129.2 kHz) & Ant. 7 (144.5 kHz ~ 147.5 kHz)

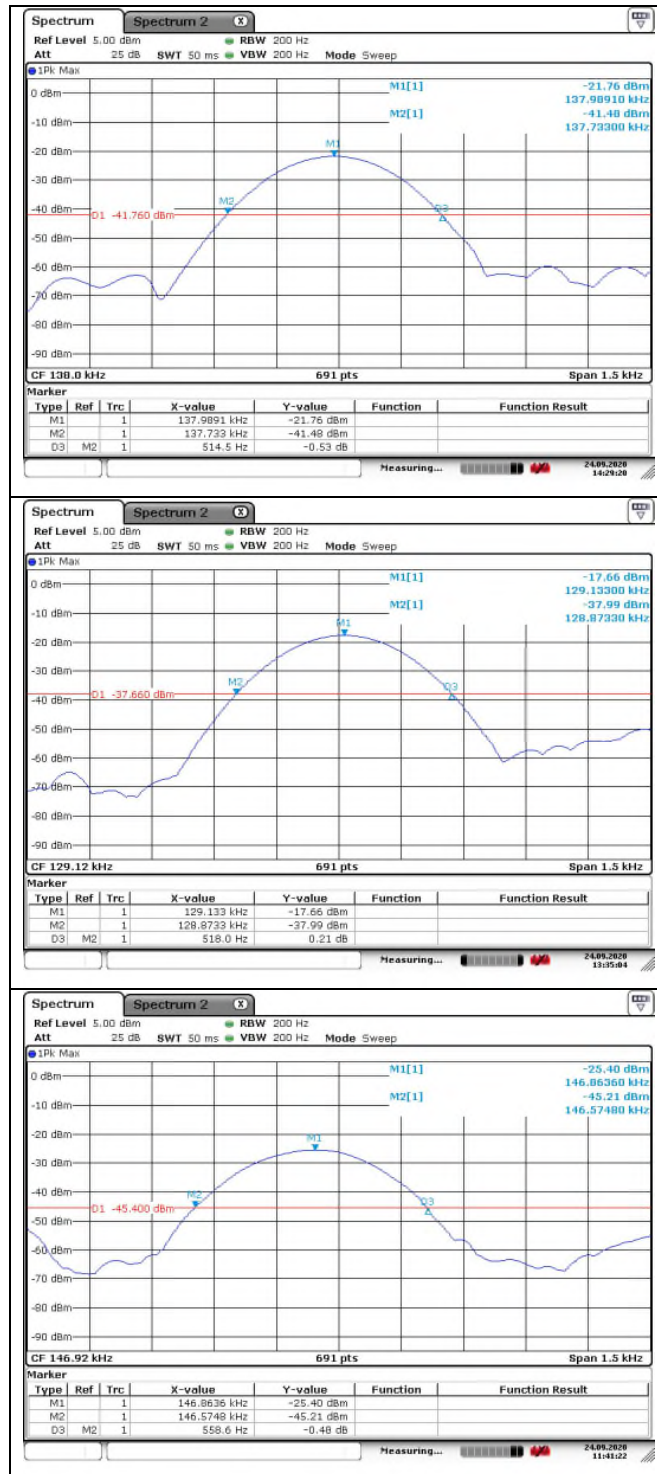

Ant. 1 (126.2 kHz ~ 129.2 kHz) & Ant. 6 (144.5 kHz ~ 147.5 kHz) & Ant. 7 (144.5 kHz ~ 147.5 kHz)

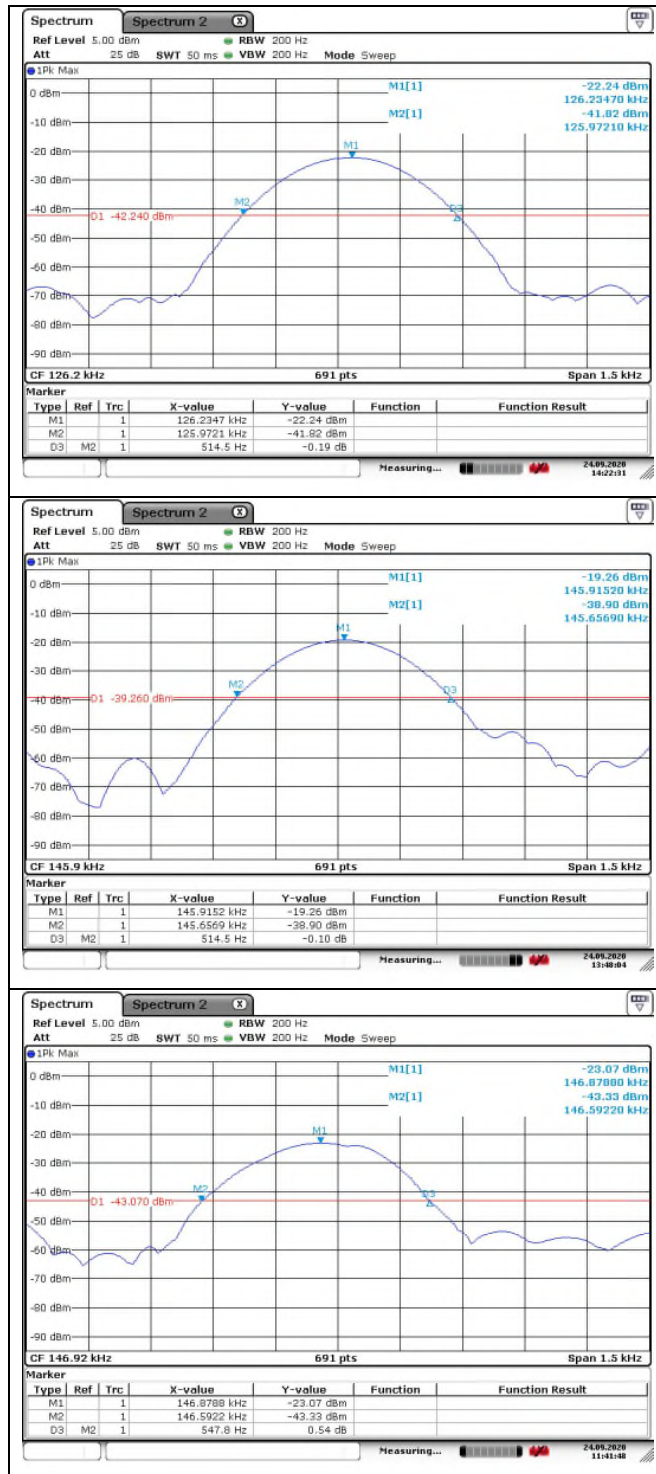

Ant. 1 (126.2 kHz ~ 129.2 kHz) & Ant. 6 (126.2 kHz ~ 129.2 kHz) & Ant. 7 (144.5 kHz ~ 147.5 kHz)

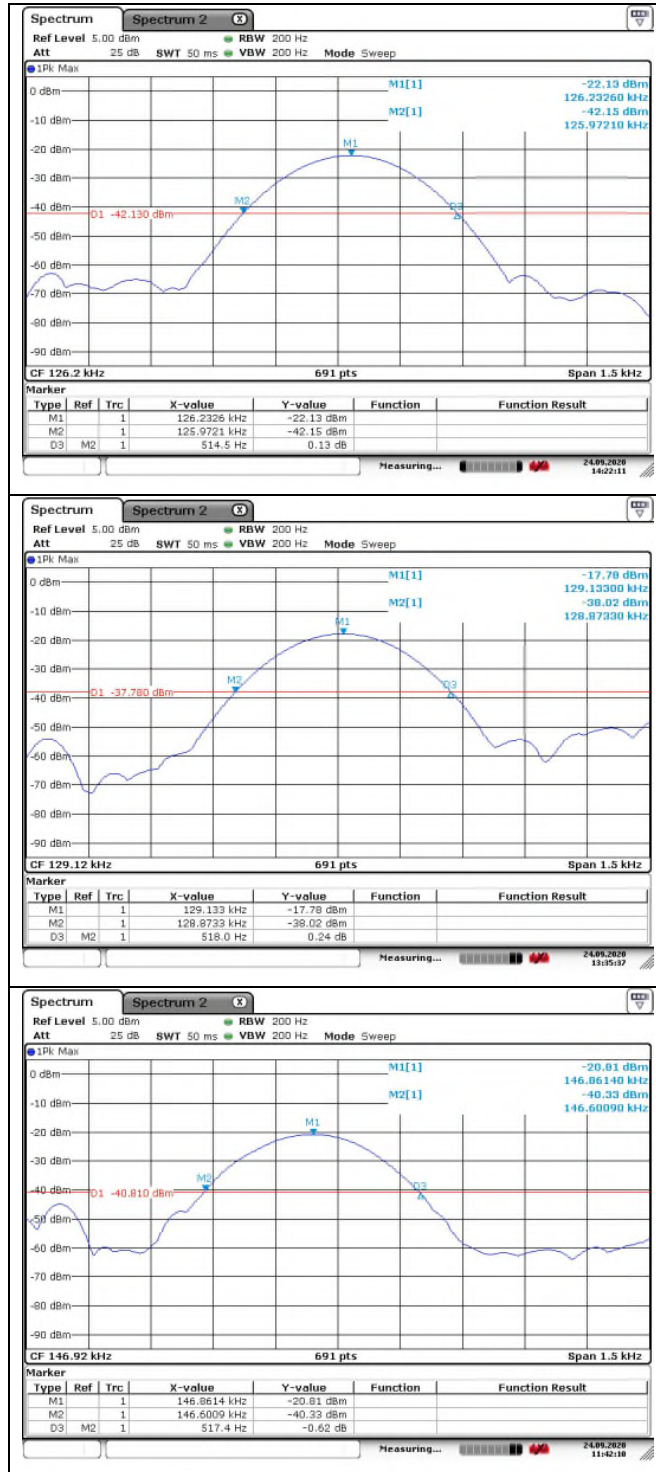

Test Condition: 2 W & 9W Operating mode with 3 client devices (1 % battery status of client device)

Ant. 1 (136.5 kHz ~ 139.5 kHz) & Ant. 6 (144.5 kHz ~ 147.5 kHz) & Ant. 7 (144.5 kHz ~ 147.5 kHz)

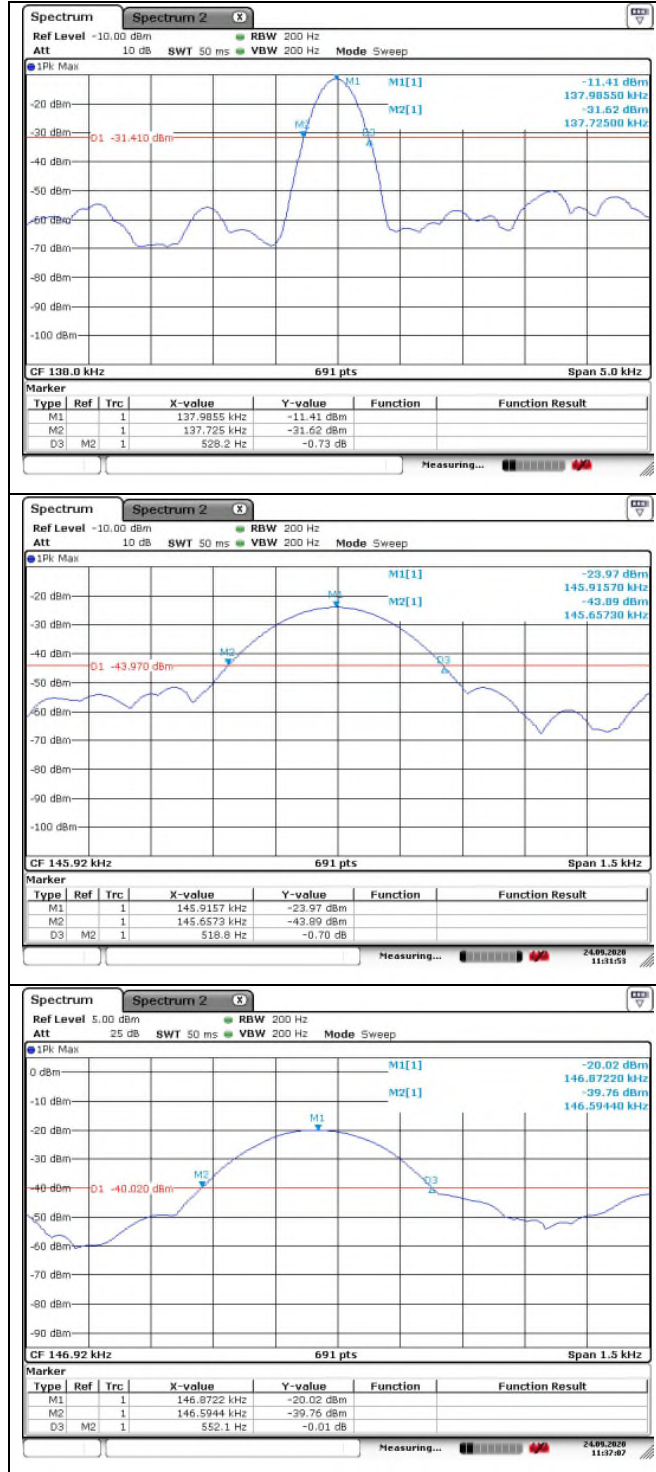

Test Condition: 2 W & 4.5W & 9W Operating mode with 3 client devices (1 % battery status of client device)

Ant. 1 (136.5 kHz ~ 139.5 kHz) & Ant. 6 (119 kHz ~ 122 kHz) & Ant. 7 (144.5 kHz ~ 147.5 kHz)

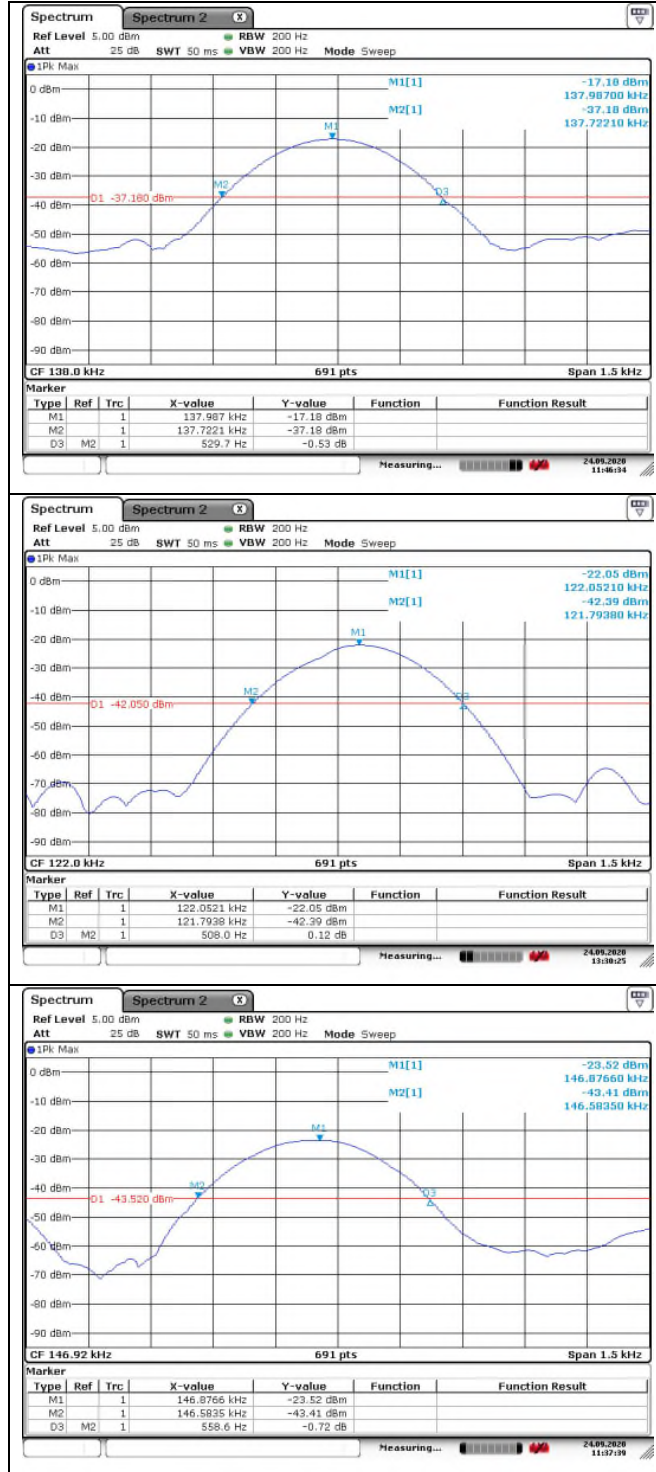

Ant. 1 (136.5 kHz ~ 139.5 kHz) & Ant. 6 (126.2 kHz ~ 129.2 kHz) & Ant. 7 (144.5 kHz ~ 147.5 kHz)

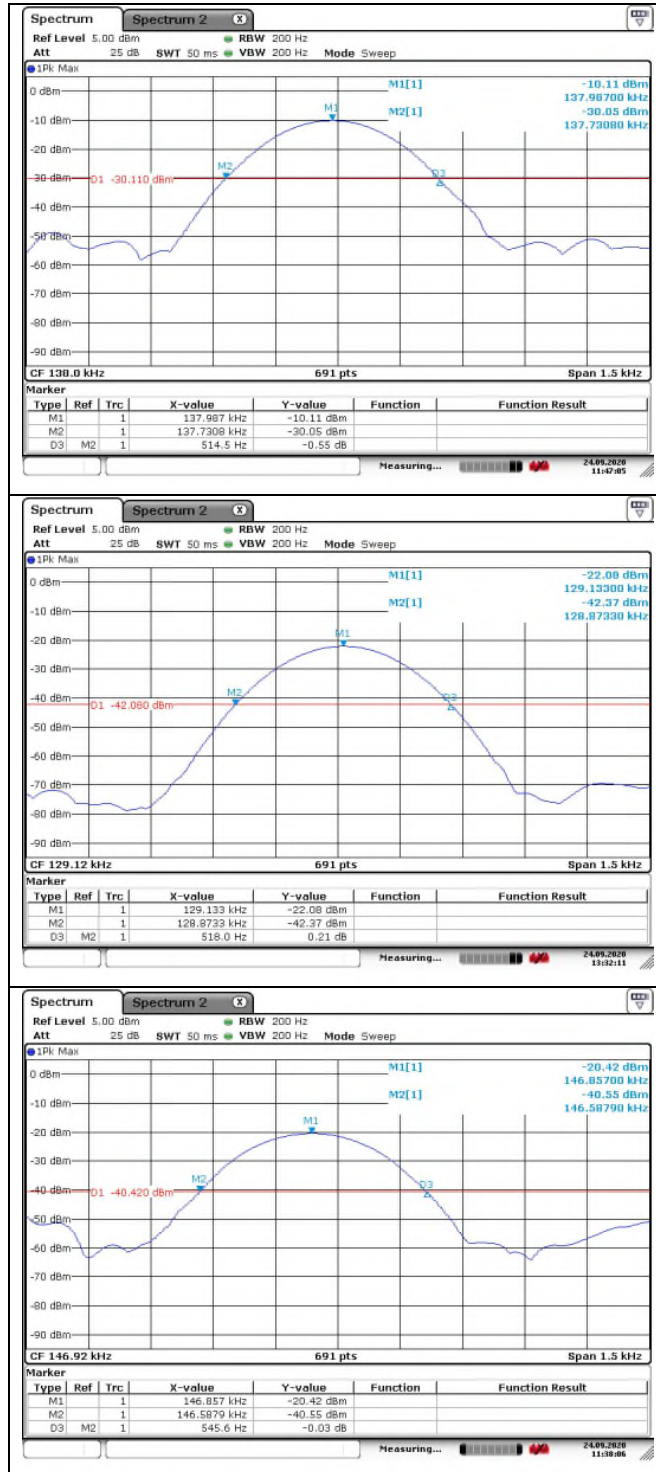

Ant. 1 (119 kHz ~ 122 kHz) & Ant. 6 (144.5 kHz ~ 147.5 kHz) & Ant. 7 (144.5 kHz ~ 147.5 kHz)

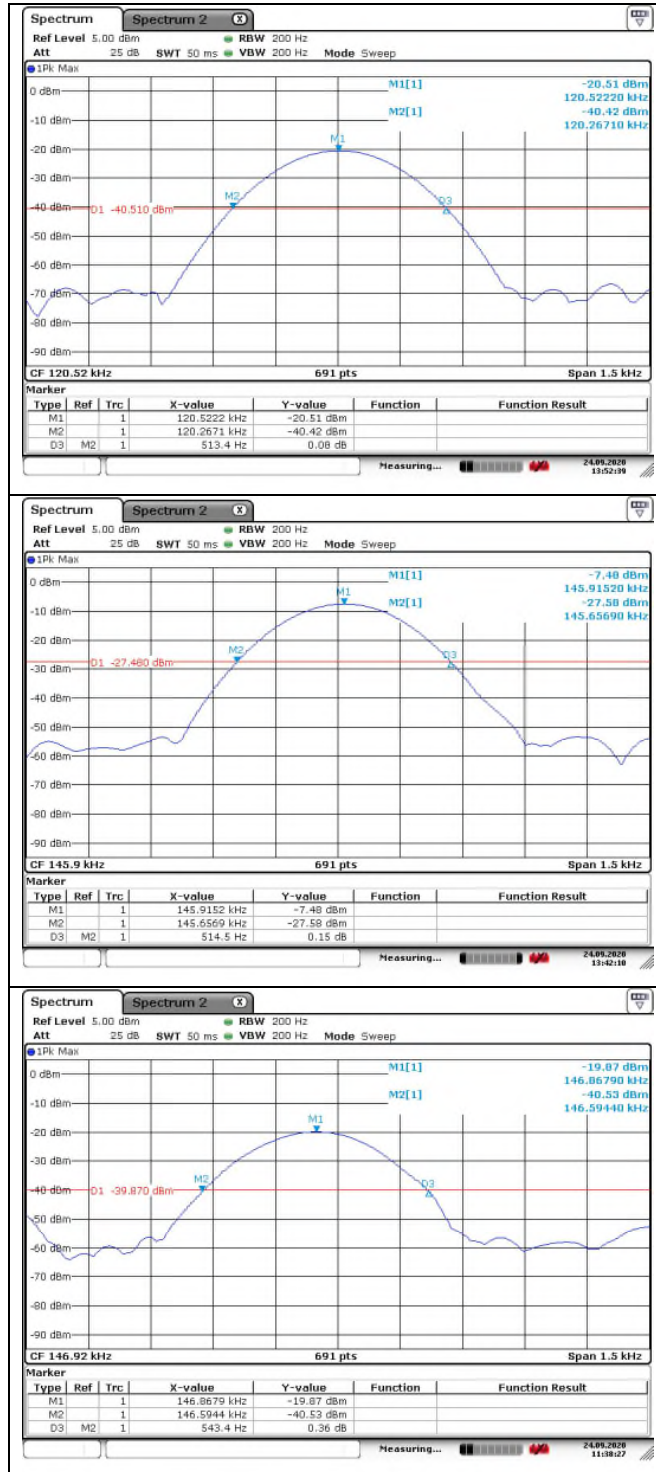

Ant. 1 (126.2 kHz ~ 129.2 kHz) & Ant. 6 (144.5 kHz ~ 147.5 kHz) & Ant. 7 (144.5 kHz ~ 147.5 kHz)

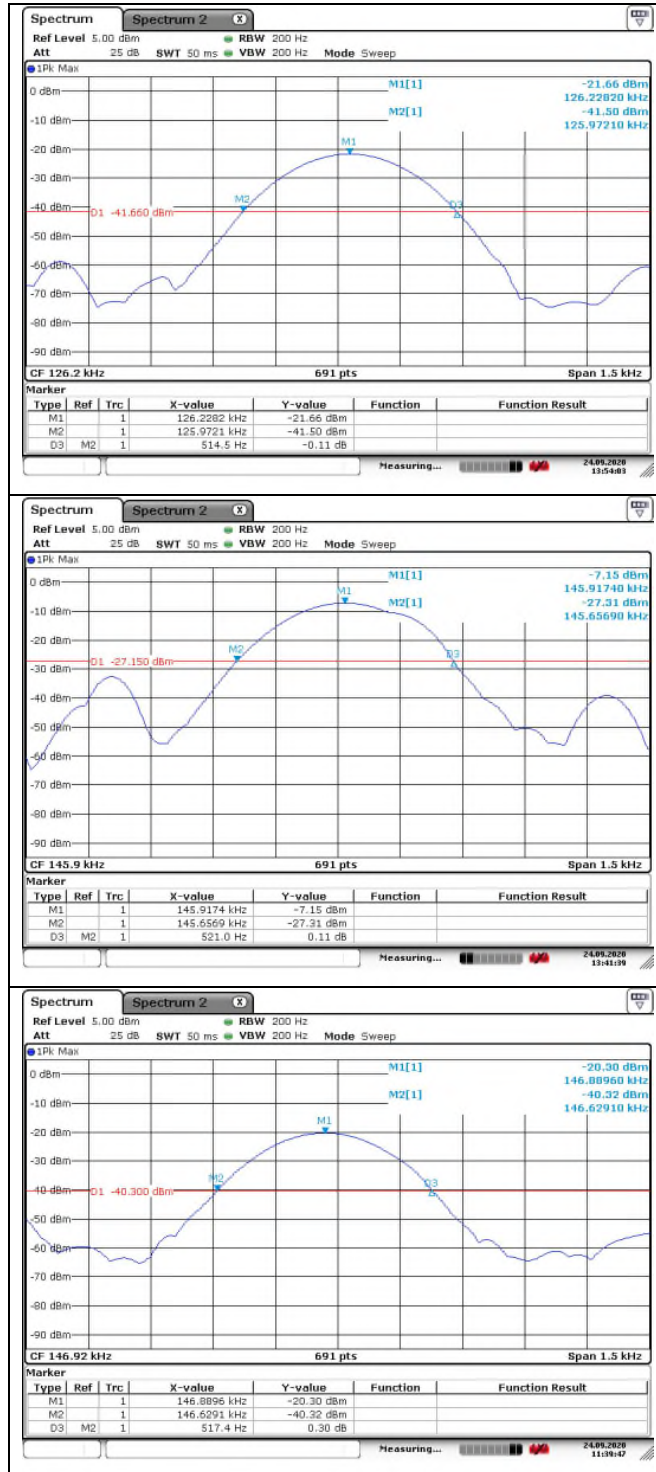

Test Condition: Ping mode with client device (Standby mode)

Ant. All (136.5 kHz ~ 139.5 kHz & 144.5 kHz ~ 147.5 kHz)

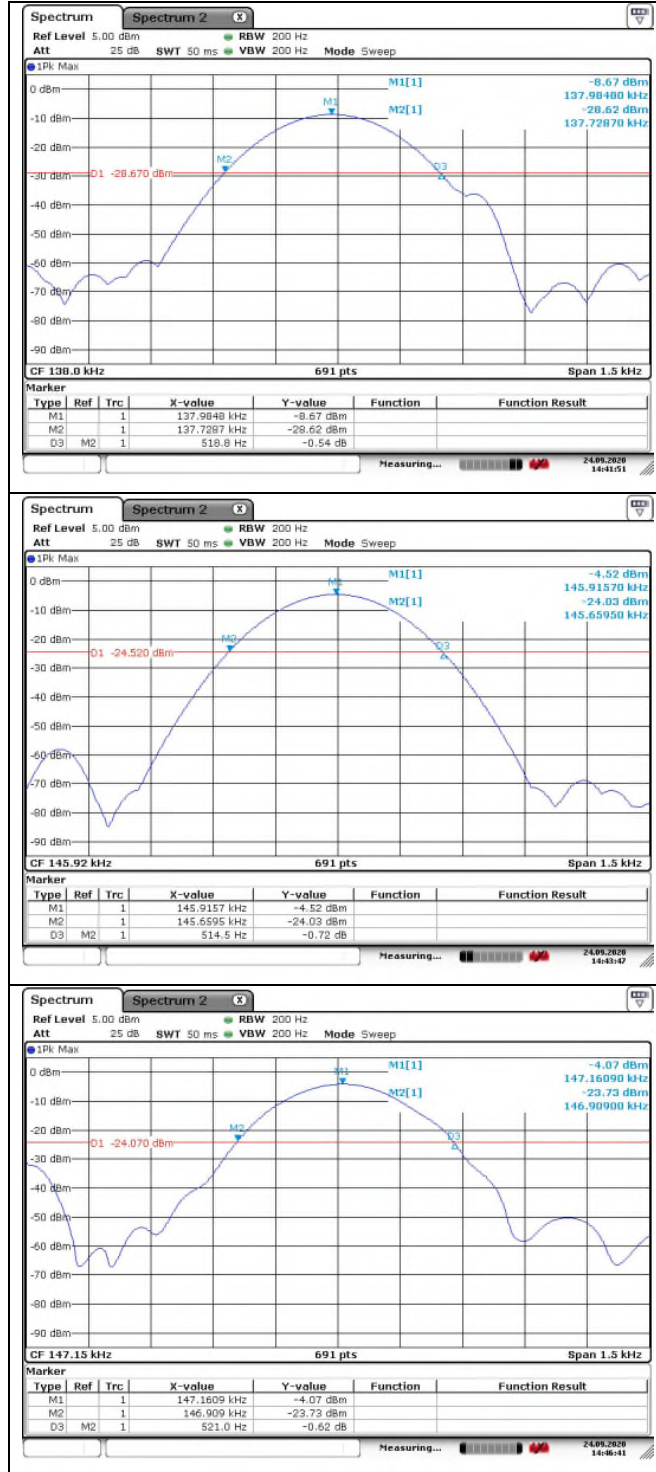

4. AC Power Line Conducted Emission

4.1. Test Setup

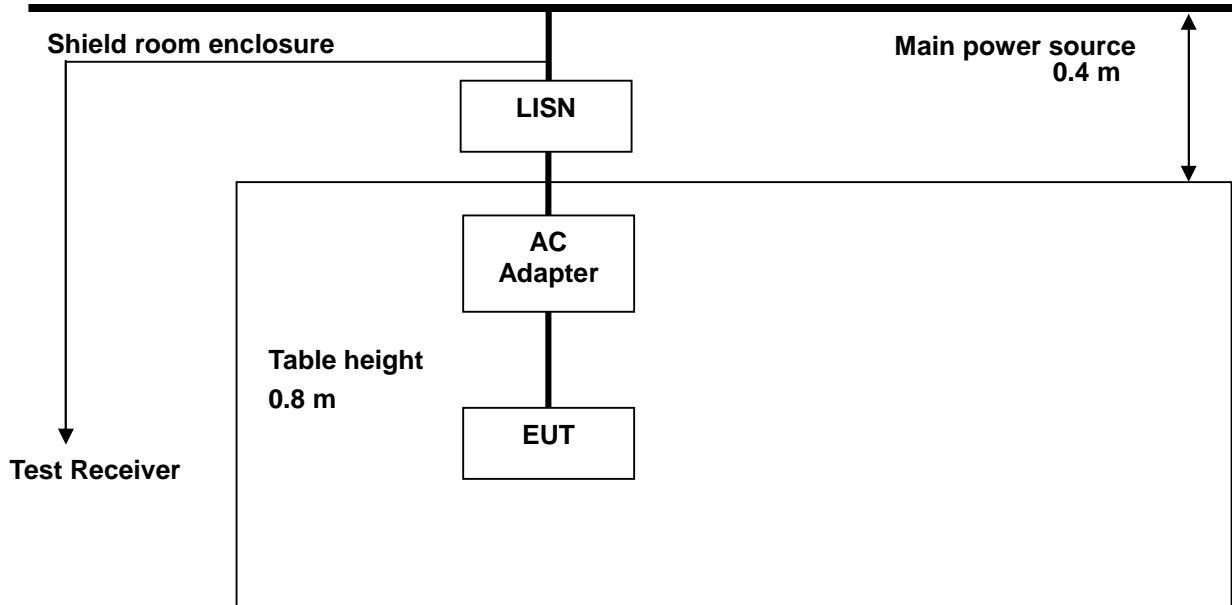

4.2. Limit

According to §15.207(a), for an intentional radiator that is designed to be connected to the public utility (AC) power line, the radio frequency voltage that is conducted back onto the AC power line on any frequency or frequencies, within the band 150 kHz to 30 MHz, shall not exceed the limits in the following table, as measured using a 50 μ H / 50 ohms line impedance stabilization network (LISN).

Compliance with the provision of this paragraph shall be based on the measurement of the radio frequency voltage between each power line and ground at the power terminal. The lower limit applies at the boundary between the frequency ranges.

Frequency of emission (MHz)	Conducted limit (dB μ V)	
	Quasi-peak	Average
0.15-0.5	66 to 56*	56 to 46*
0.5-5	56	46
5-30	60	50

* Decreases with the logarithm of the frequency.

4.3. Test Procedures

AC conducted emissions from the EUT were measured according to the dictates of ANSI C63.10:2013

1. The test procedure is performed in a 6.5 m × 3.5 m × 3.5 m (L × W × H) shielded room. The EUT along with its peripherals were placed on a 1.0 m (W) × 1.5 m (L) and 0.8 m in height wooden table and the EUT was adjusted to maintain a 0.4 meter space from a vertical reference plane.
2. The EUT was connected to power mains through a line impedance stabilization network (LISN) which provides 50 ohm coupling impedance for measuring instrument and the chassis ground was bounded to the horizontal ground plane of shielded room.
3. All peripherals were connected to the second LISN and the chassis ground also bounded to the horizontal ground plane of shielded room.
4. The excess power cable between the EUT and the LISN was bundled. The power cables of peripherals were unbundled. All connecting cables of EUT and peripherals were moved to find the maximum emission.

4.4. Test Results

The following table shows the highest levels of conducted emissions on both phase of Hot and Neutral line.

Ambient temperature : (23 ± 1) °C
 Relative humidity : 47 % R.H.
 Frequency range : 0.15 MHz – 30 MHz
 Measured Bandwidth : 9 kHz

Test Condition: 2 W Operating mode with client device (1 % battery status of client device)

Ant. 7 (144.5 kHz ~ 147.5 kHz)

FREQ. (MHz)	LEVEL (dB μ V)		LINE	LIMIT (dB μ V)		MARGIN (dB)	
	Q-Peak	Average		Q-Peak	Average	Q-Peak	Average
0.16	45.80	25.80	N	65.46	55.46	19.66	29.66
0.27	39.10	21.90	N	61.12	51.12	22.02	29.22
0.48	35.00	27.80	N	56.34	46.34	21.34	18.54
3.76	22.30	14.90	N	56.00	46.00	33.70	31.10
13.04	21.10	15.10	N	60.00	50.00	38.90	34.90
19.72	26.20	19.00	N	60.00	50.00	33.80	31.00
0.17	44.90	25.80	H	64.96	54.96	20.06	29.16
0.28	36.70	16.60	H	60.82	50.82	24.12	34.22
0.48	31.10	21.30	H	56.34	46.34	25.24	25.04
4.28	16.20	12.60	H	56.00	46.00	39.80	33.40
12.54	17.70	13.10	H	60.00	50.00	42.30	36.90
19.82	23.70	19.00	H	60.00	50.00	36.30	31.00

Remark;

1. Line (H): Hot, Line (N): Neutral
2. Each charging mode with client device (1 %, 50 % and 99 % of battery) was tested. As worst condition, charging mode with client device (1 %) is reported.
3. The limit for Class B device(s) from 150 kHz to 30 MHz are specified in section of the Title 47 CFR.
4. Traces shown in plot were made by using a peak detector and average detector.
5. Deviations to the Specifications: None.

- Test plots

Test mode: (Neutral)

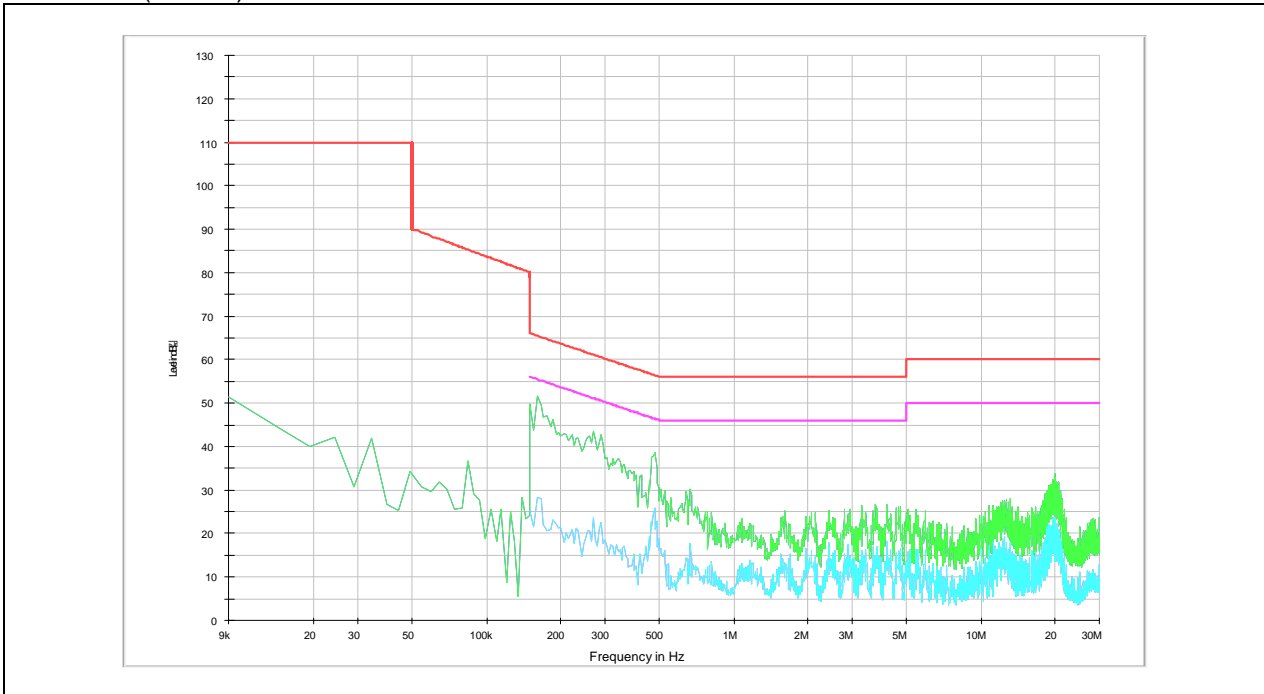

Test mode: (Hot)

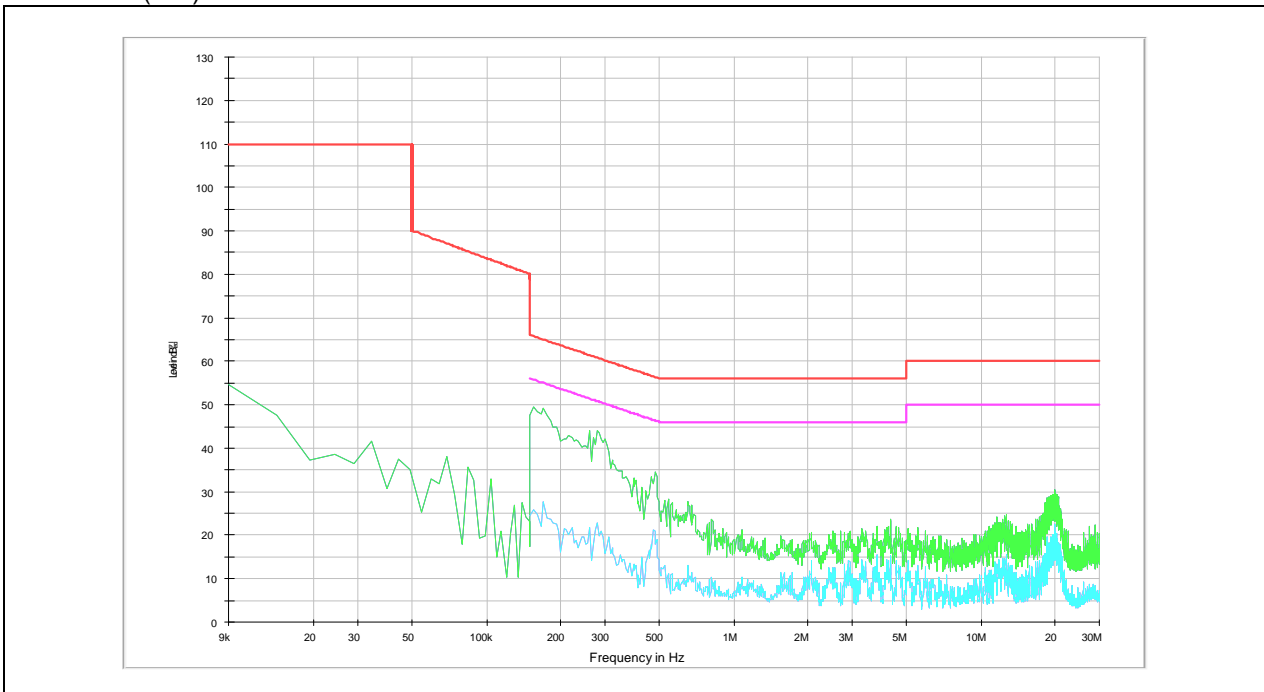

Test Condition: 4.5 W Operating mode with client device (1 % battery status of client device)

Ant. 1 (119 kHz ~ 122 kHz)

FREQ. (MHz)	LEVEL (dB μ V)		LINE	LIMIT (dB μ V)		MARGIN (dB)	
	Q-Peak	Average		Q-Peak	Average	Q-Peak	Average
0.16	48.20	27.50	N	65.46	55.46	17.26	27.96
0.48	45.40	30.30	N	56.34	46.34	10.94	16.04
2.48	18.80	13.00	N	56.00	46.00	37.20	33.00
12.48	27.00	19.20	N	60.00	50.00	33.00	30.80
19.83	29.10	21.90	N	60.00	50.00	30.90	28.10
28.68	24.70	19.30	N	60.00	50.00	35.30	30.70
0.16	48.90	28.40	H	65.46	55.46	16.56	27.06
0.22	42.60	22.70	H	62.82	52.82	20.22	30.12
0.48	34.70	26.50	H	56.34	46.34	21.64	19.84
2.52	26.00	22.70	H	56.00	46.00	30.00	23.30
12.59	20.10	15.50	H	60.00	50.00	39.90	34.50
19.66	25.10	18.50	H	60.00	50.00	34.90	31.50

Remark;

1. Line (H): Hot, Line (N): Neutral
2. Each charging mode with client device (1 %, 50 % and 99 % of battery) was tested.
As worst condition, charging mode with client device (1 %) is reported.
3. The limit for Class B device(s) from 150 kHz to 30 MHz are specified in section of the Title 47 CFR.
4. Traces shown in plot were made by using a peak detector and average detector.
5. Deviations to the Specifications: None.

- Test plots

Test mode: (Neutral)

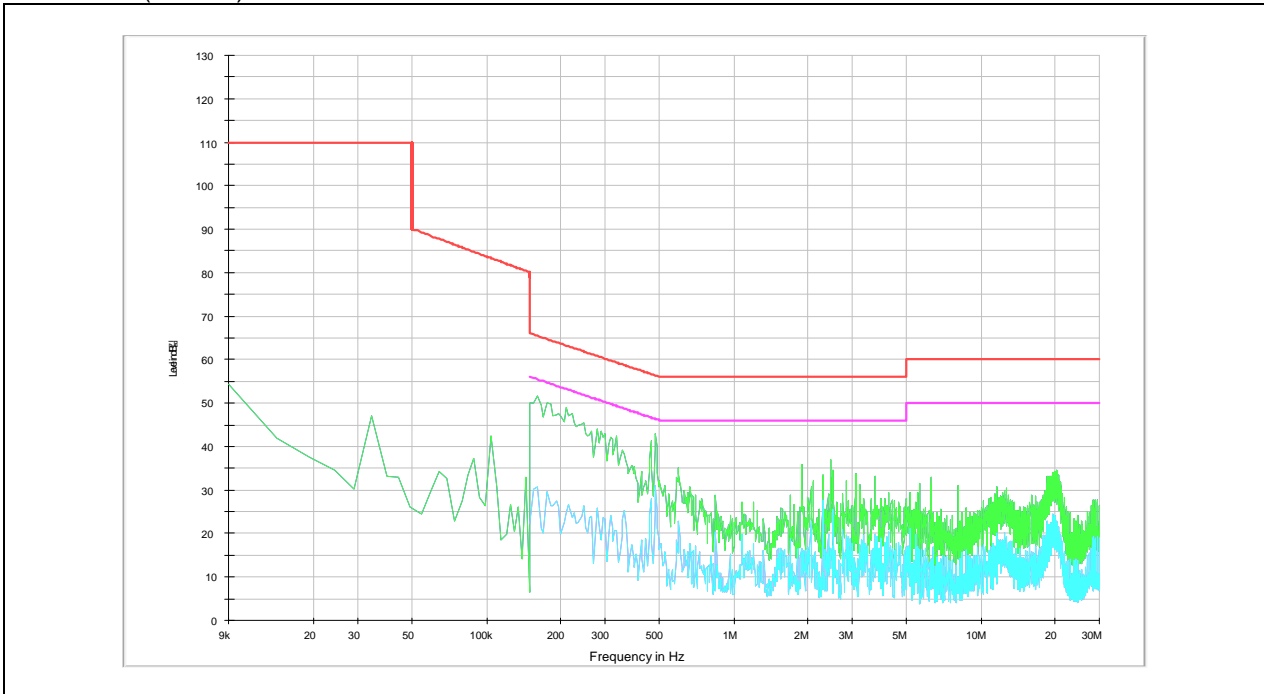

Test mode: (Hot)

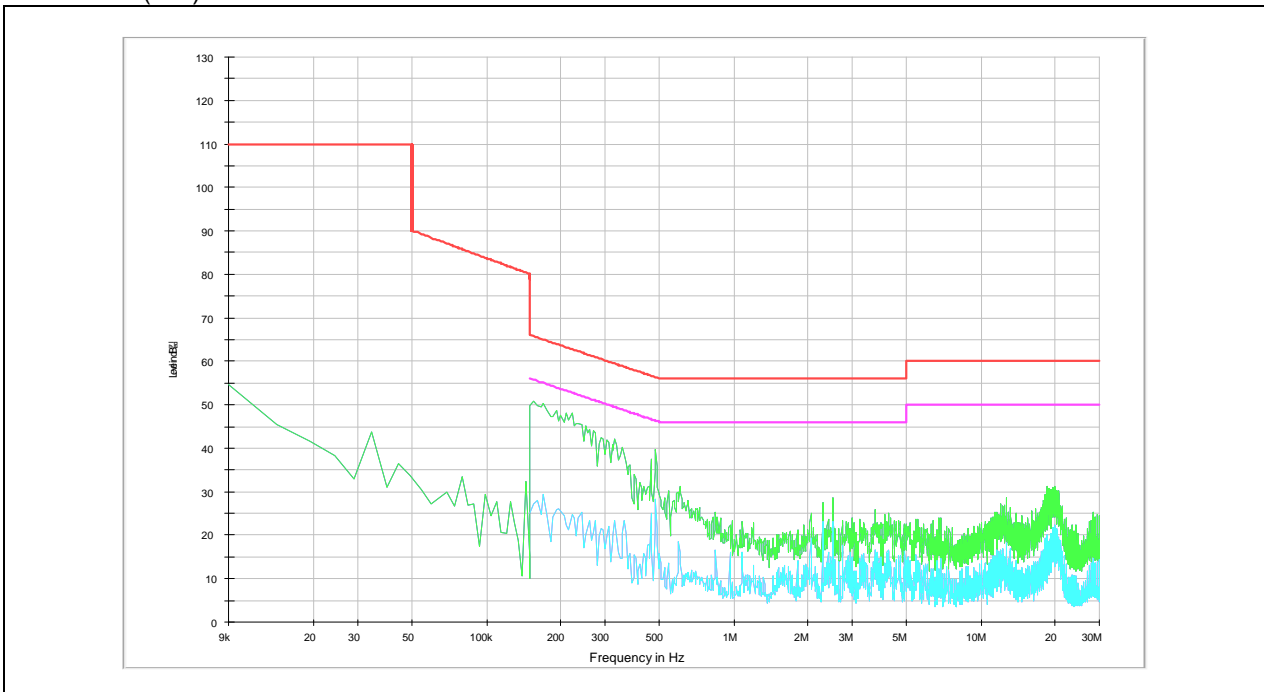

Test Condition: 4.5 W Operating mode with client device (1 % battery status of client device)

Ant. 1 (126.2 kHz ~ 129.2 kHz)

FREQ. (MHz)	LEVEL (dB μ V)		LINE	LIMIT (dB μ V)		MARGIN (dB)	
	Q-Peak	Average		Q-Peak	Average	Q-Peak	Average
0.16	47.60	47.60	N	65.46	55.46	17.86	7.86
0.18	43.60	43.60	N	64.49	54.49	20.89	10.89
0.48	38.30	38.30	N	56.34	46.34	18.04	8.04
2.40	33.00	33.00	N	56.00	46.00	23.00	13.00
10.35	24.23	24.20	N	60.00	50.00	35.77	25.80
19.45	30.10	30.10	N	60.00	50.00	29.90	19.90
0.15	49.20	28.70	H	66.00	56.00	16.80	27.30
0.20	44.10	24.00	H	63.61	53.61	19.51	29.61
0.48	34.10	23.50	H	56.34	46.34	22.24	22.84
2.40	27.20	23.80	H	56.00	46.00	28.80	22.20
12.25	21.20	14.30	H	60.00	50.00	38.80	35.70
18.81	25.40	17.40	H	60.00	50.00	34.60	32.60

Remark;

1. Line (H): Hot, Line (N): Neutral
2. Each charging mode with client device (1 %, 50 % and 99 % of battery) was tested.
As worst condition, charging mode with client device (1 %) is reported.
3. The limit for Class B device(s) from 150 kHz to 30 MHz are specified in section of the Title 47 CFR.
4. Traces shown in plot were made by using a peak detector and average detector.
5. Deviations to the Specifications: None.

- Test plots

Test mode: (Neutral)

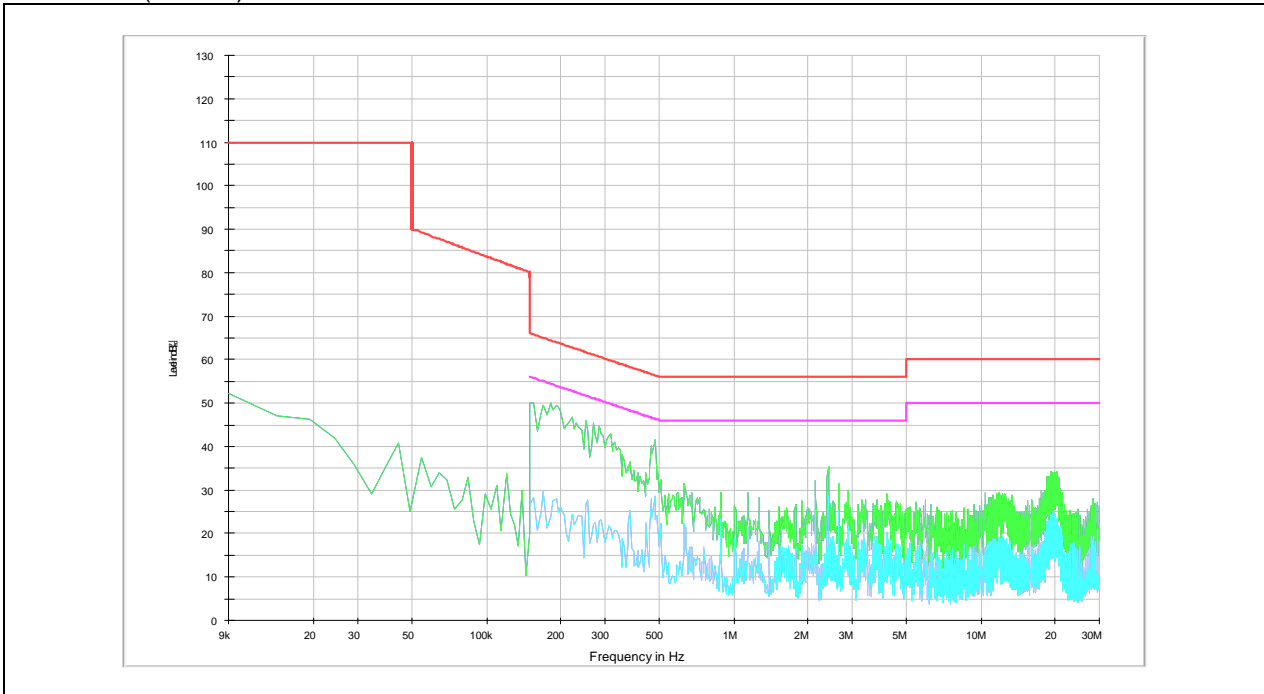

Test mode: (Hot)

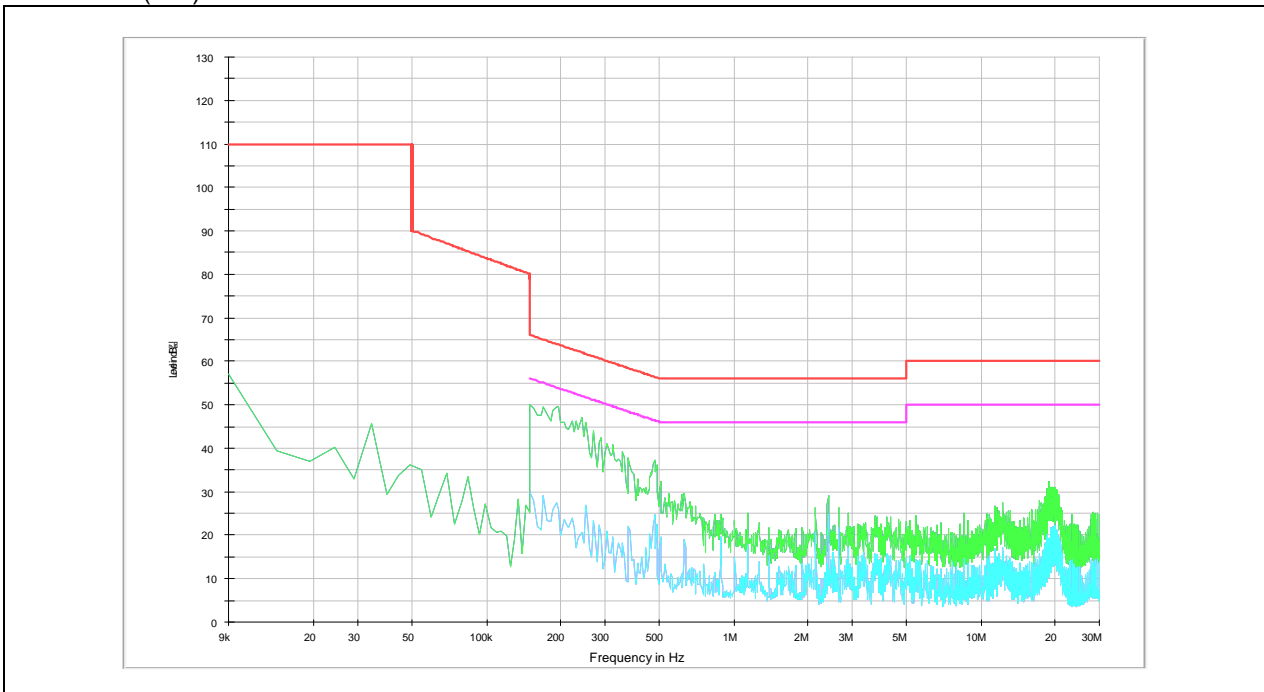

Test Condition: 4.5 W Operating mode with client device (1 % battery status of client device)

Ant. 6 (119 kHz ~ 122 kHz)

FREQ. (MHz)	LEVEL (dB μ V)		LINE	LIMIT (dB μ V)		MARGIN (dB)	
	Q-Peak	Average		Q-Peak	Average	Q-Peak	Average
0.16	46.40	26.50	N	65.46	55.46	19.06	28.96
0.19	46.30	27.20	N	64.04	54.04	17.74	26.84
0.48	33.90	24.00	N	56.34	46.34	22.44	22.34
2.08	28.00	22.50	N	56.00	46.00	28.00	23.50
12.45	28.90	21.70	N	60.00	50.00	31.10	28.30
19.83	26.40	18.00	N	60.00	50.00	33.60	32.00
0.15	51.70	33.20	H	66.00	56.00	14.30	22.80
0.17	48.30	29.30	H	64.96	54.96	16.66	25.66
0.48	29.00	20.80	H	56.34	46.34	27.34	25.54
4.76	20.50	14.60	H	56.00	46.00	35.50	31.40
12.65	24.70	19.00	H	60.00	50.00	35.30	31.00
19.04	21.90	14.80	H	60.00	50.00	38.10	35.20

Remark;

1. Line (H): Hot, Line (N): Neutral
2. Each charging mode with client device (1 %, 50 % and 99 % of battery) was tested.
As worst condition, charging mode with client device (1 %) is reported.
3. The limit for Class B device(s) from 150 kHz to 30 MHz are specified in section of the Title 47 CFR.
4. Traces shown in plot were made by using a peak detector and average detector.
5. Deviations to the Specifications: None.

- Test plots

Test mode: (Neutral)

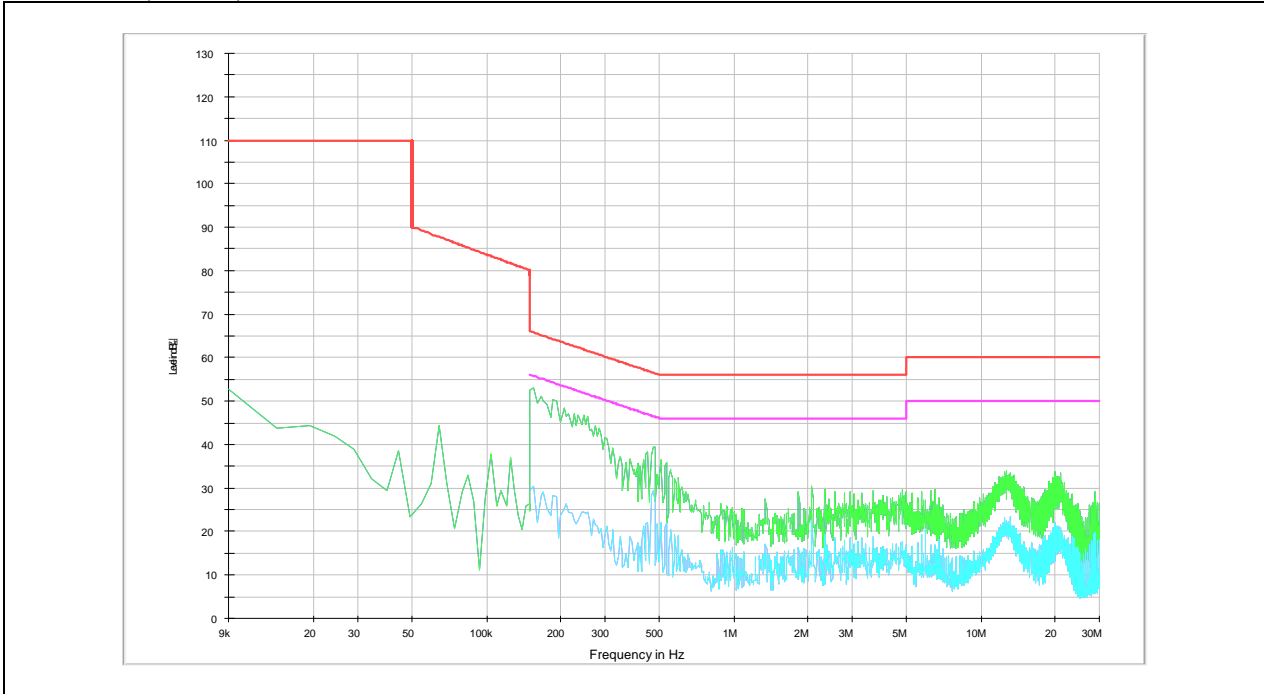

Test mode: (Hot)

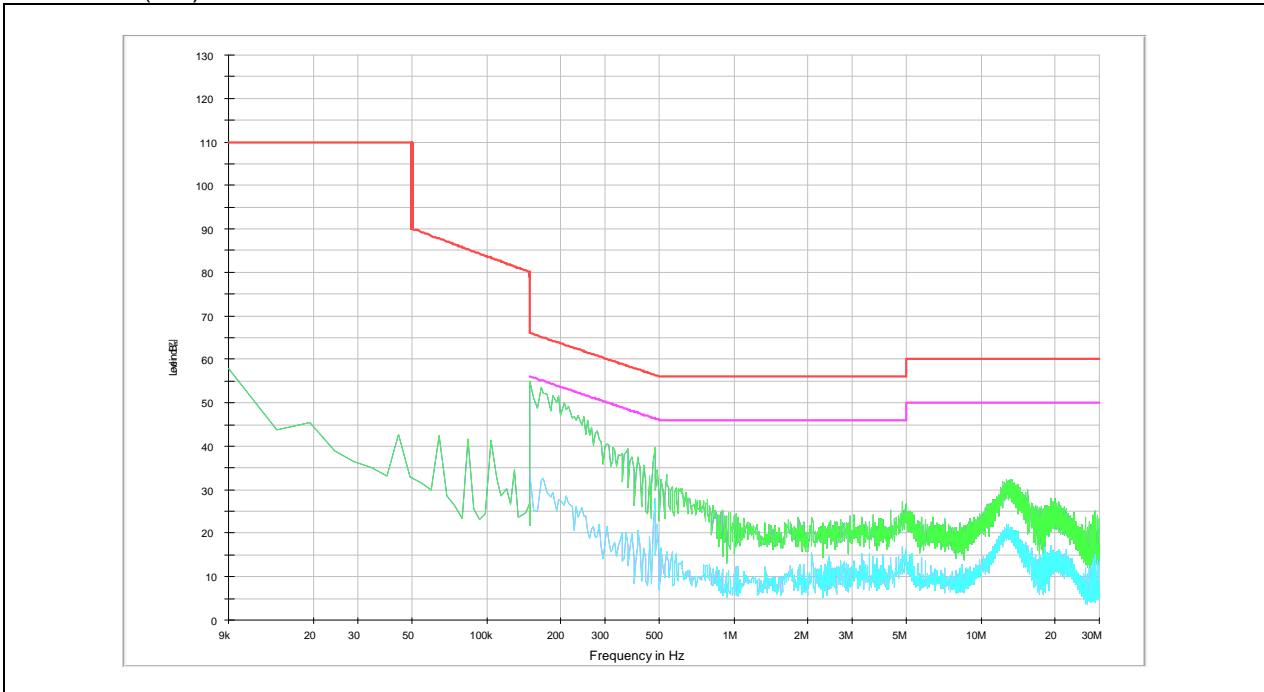

Test Condition: 4.5 W Operating mode with client device (1 % battery status of client device)

Ant. 6 (126.2 kHz ~ 129.2 kHz)

FREQ. (MHz)	LEVEL (dB μ V)		LINE	LIMIT (dB μ V)		MARGIN (dB)	
	Q-Peak	Average		Q-Peak	Average	Q-Peak	Average
0.15	49.30	31.80	N	66.00	56.00	16.70	24.20
0.47	30.20	24.40	N	56.51	46.51	26.31	22.11
2.20	29.50	24.70	N	56.00	46.00	26.50	21.30
3.23	27.60	21.60	N	56.00	46.00	28.40	24.40
12.49	26.30	19.30	N	60.00	50.00	33.70	30.70
19.57	29.90	21.90	N	60.00	50.00	30.10	28.10
0.15	49.60	31.90	H	66.00	56.00	16.40	24.10
0.17	47.60	28.60	H	64.96	54.96	17.36	26.36
0.48	34.90	25.50	H	56.34	46.34	21.44	20.84
4.00	20.30	15.60	H	56.00	46.00	35.70	30.40
12.59	21.70	15.10	H	60.00	50.00	38.30	34.90
19.76	25.40	19.80	H	60.00	50.00	34.60	30.20

Remark;

1. Line (H): Hot, Line (N): Neutral
2. Each charging mode with client device (1 %, 50 % and 99 % of battery) was tested.
As worst condition, charging mode with client device (1 %) is reported.
3. The limit for Class B device(s) from 150 kHz to 30 MHz are specified in section of the Title 47 CFR.
4. Traces shown in plot were made by using a peak detector and average detector.
5. Deviations to the Specifications: None.

- Test plots

Test mode: (Neutral)

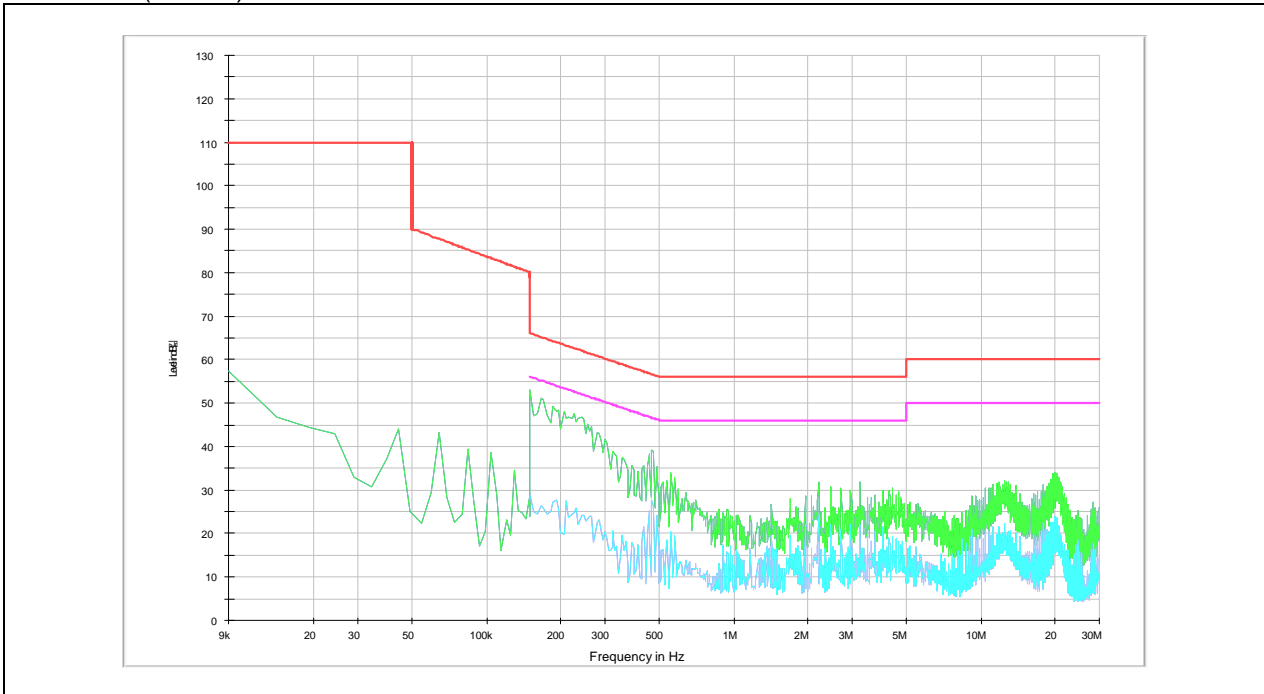

Test mode: (Hot)

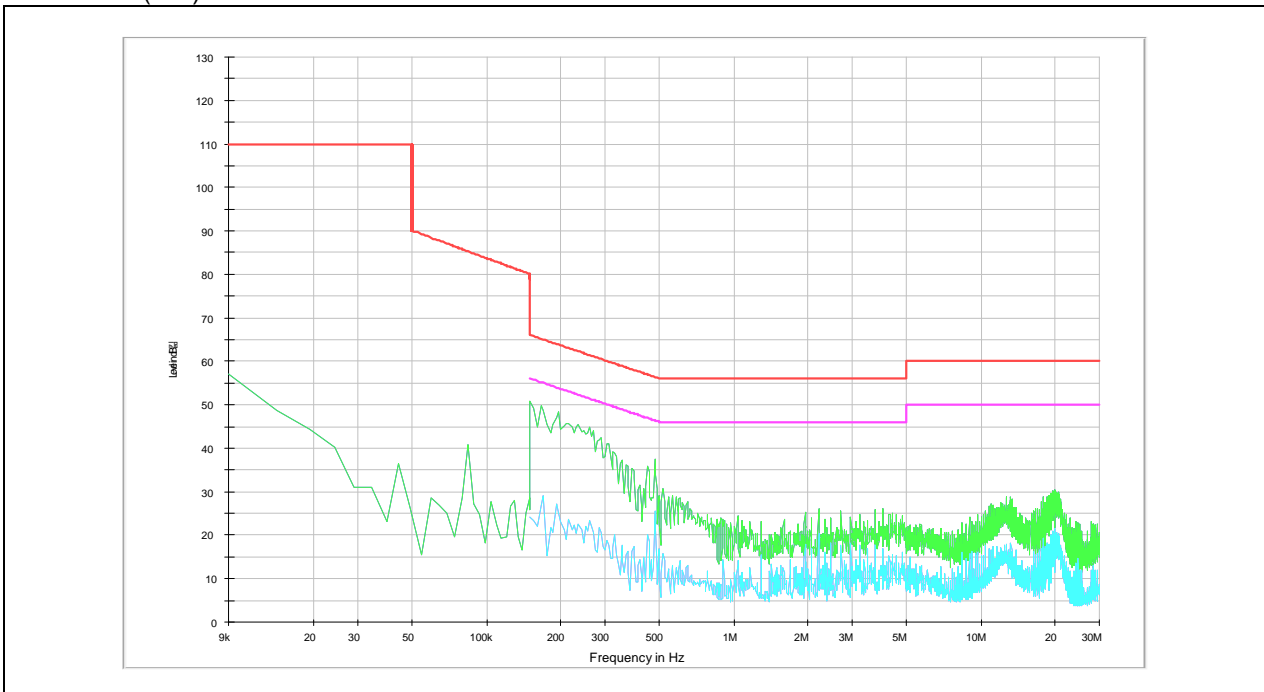

Test Condition: 9 W Operating mode with client device (1 % battery status of client device)

Ant. 1 (136.5 kHz ~ 139.5 kHz)

FREQ. (MHz)	LEVEL (dB μ V)		LINE	LIMIT (dB μ V)		MARGIN (dB)	
	Q-Peak	Average		Q-Peak	Average	Q-Peak	Average
0.15	53.30	40.00	N	66.00	56.00	12.70	16.00
0.18	49.80	29.00	N	64.49	54.49	14.69	25.49
0.48	40.30	31.10	N	56.34	46.34	16.04	15.24
2.62	28.30	21.80	N	56.00	46.00	27.70	24.20
12.68	28.30	21.50	N	60.00	50.00	31.70	28.50
19.78	29.30	20.00	N	60.00	50.00	30.70	30.00
0.17	53.00	42.50	H	64.96	54.96	11.96	12.46
0.20	48.10	28.30	H	63.61	53.61	15.51	25.31
0.23	46.80	27.00	H	62.45	52.45	15.65	25.45
0.48	38.10	28.60	H	56.34	46.34	18.24	17.74
12.69	24.60	18.10	H	60.00	50.00	35.40	31.90
19.61	25.80	18.30	H	60.00	50.00	34.20	31.70

Remark;

- Line (H): Hot, Line (N): Neutral
- Each charging mode with client device (1 %, 50 % and 99 % of battery) was tested. As worst condition, charging mode with client device (1 %) is reported.
- The limit for Class B device(s) from 150 kHz to 30 MHz are specified in section of the Title 47 CFR.
- Traces shown in plot were made by using a peak detector and average detector.
- Deviations to the Specifications: None.

- Test plots

Test mode: (Neutral)

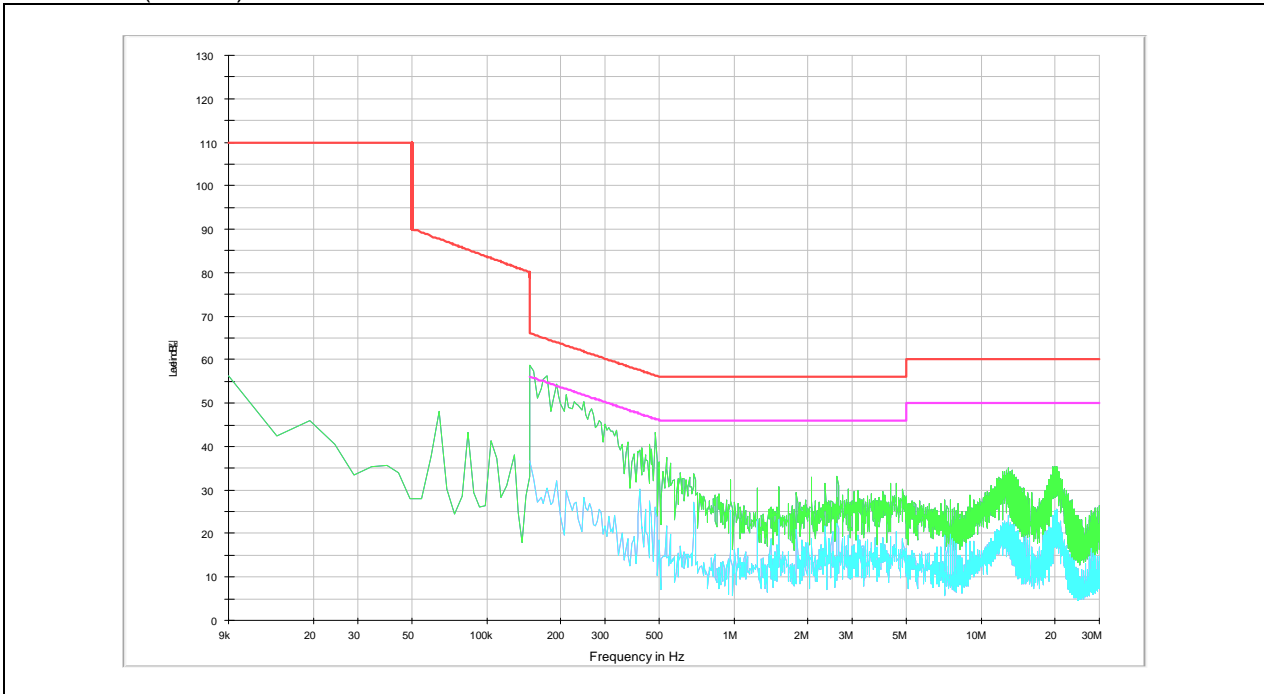

Test mode: (Hot)

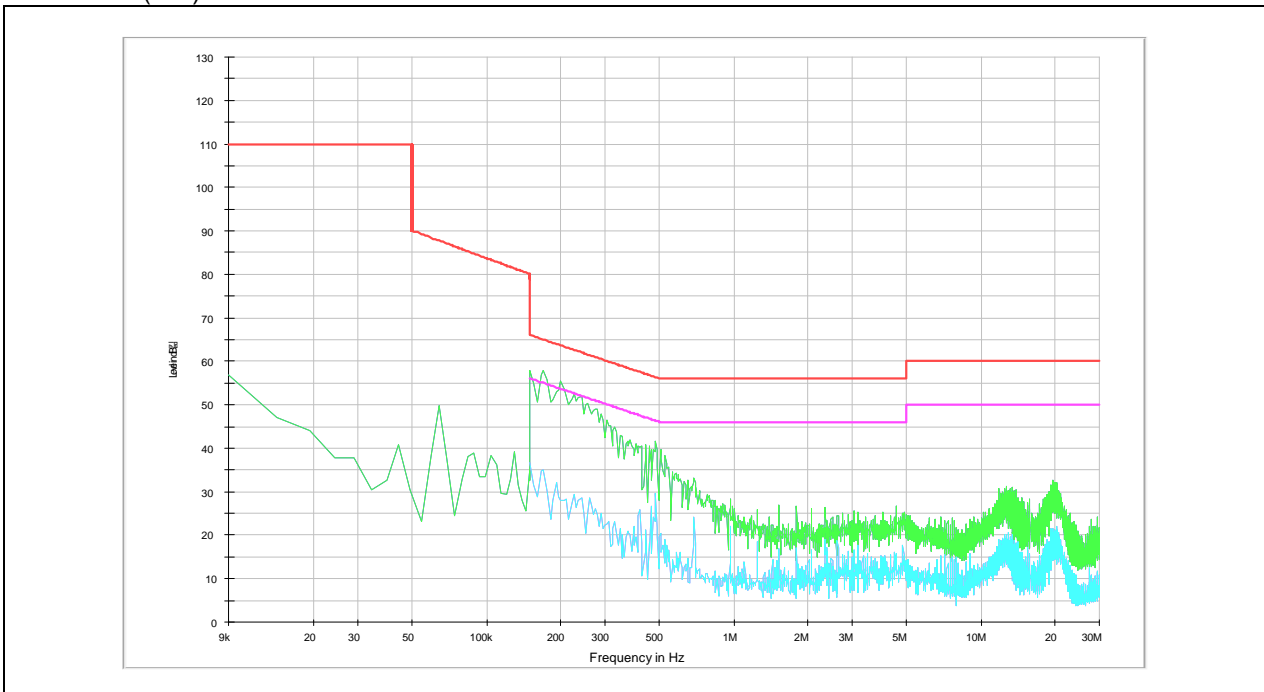

Test Condition: 9 W Operating mode with client device (1 % battery status of client device)

Ant. 6 (144.5 kHz ~ 147.5 kHz)

FREQ. (MHz)	LEVEL (dB μ V)		LINE	LIMIT (dB μ V)		MARGIN (dB)	
	Q-Peak	Average		Q-Peak	Average	Q-Peak	Average
0.15	53.50	42.10	N	66.00	56.00	12.50	13.90
0.17	51.20	31.90	N	64.96	54.96	13.76	23.06
0.48	40.40	30.70	N	56.34	46.34	15.94	15.64
4.94	24.10	15.80	N	56.00	46.00	31.90	30.20
13.39	30.00	23.10	N	60.00	50.00	30.00	26.90
18.54	23.40	16.50	N	60.00	50.00	36.60	33.50
0.15	50.40	32.50	H	66.00	56.00	15.60	23.50
0.19	46.80	27.00	H	64.04	54.04	17.24	27.04
0.35	34.80	17.60	H	58.96	48.96	24.16	31.36
13.17	23.80	17.80	H	60.00	50.00	36.20	32.20
19.19	22.90	15.70	H	60.00	50.00	37.10	34.30
28.46	24.20	18.00	H	60.00	50.00	35.80	32.00

Remark;

1. Line (H): Hot, Line (N): Neutral
2. Each charging mode with client device (1 %, 50 % and 99 % of battery) was tested.
As worst condition, charging mode with client device (1 %) is reported.
3. The limit for Class B device(s) from 150 kHz to 30 MHz are specified in section of the Title 47 CFR.
4. Traces shown in plot were made by using a peak detector and average detector.
5. Deviations to the Specifications: None.

- Test plots

Test mode: (Neutral)

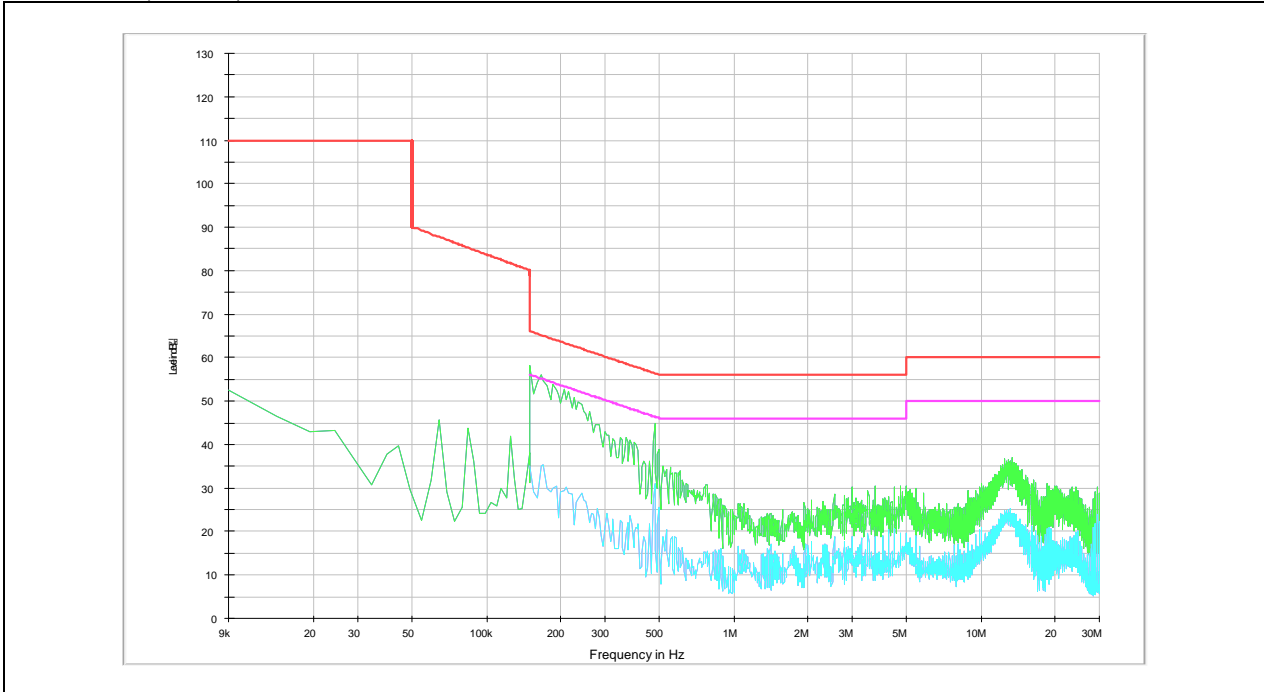

Test mode: (Hot)

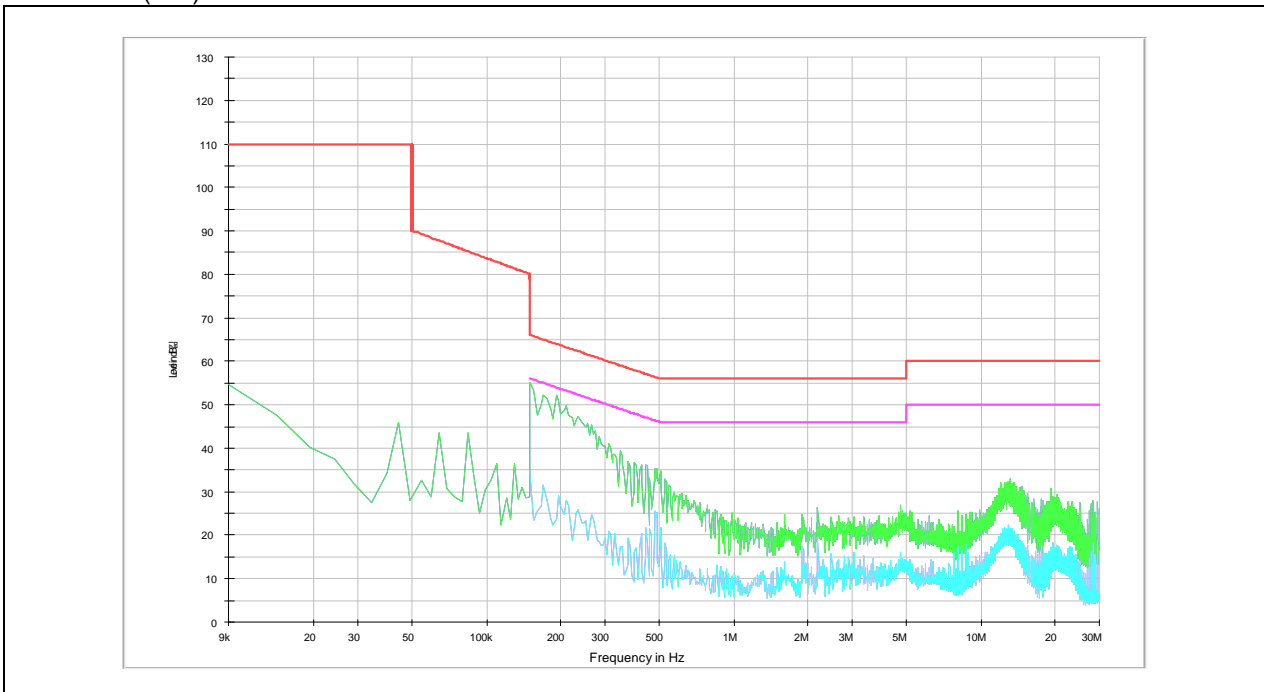

Test Condition: 2 W & 4.5W Operating mode with 3 client devices (1 % battery status of client device)

Ant. 1 (119 kHz ~ 122 kHz) & Ant. 6 (119 kHz ~ 122 kHz) & Ant. 7 (144.5 kHz ~ 147.5 kHz)

FREQ. (MHz)	LEVEL (dBμV)		LINE	LIMIT (dBμV)		MARGIN (dB)	
	Q-Peak	Average		Q-Peak	Average	Q-Peak	Average
0.15	52.90	38.70	N	66.00	56.00	13.10	17.30
0.48	38.80	30.60	N	56.34	46.34	17.54	15.74
1.15	26.40	21.10	N	56.00	46.00	29.60	24.90
2.43	32.90	27.60	N	56.00	46.00	23.10	18.40
12.77	23.50	16.10	N	60.00	50.00	36.50	33.90
19.40	27.60	20.00	N	60.00	50.00	32.40	30.00
0.15	53.20	33.90	H	66.00	56.00	12.80	22.10
0.20	48.40	27.60	H	63.61	53.61	15.21	26.01
0.48	40.90	27.00	H	56.34	46.34	15.44	19.34
2.43	28.10	25.20	H	56.00	46.00	27.90	20.80
12.56	18.90	12.60	H	60.00	50.00	41.10	37.40
19.72	22.70	17.70	H	60.00	50.00	37.30	32.30

Remark;

- Line (H): Hot, Line (N): Neutral
- Each charging mode with client device (1 %, 50 % and 99 % of battery) was tested. As worst condition, charging mode with client device (1 %) is reported.
- The limit for Class B device(s) from 150 kHz to 30 MHz are specified in section of the Title 47 CFR.
- Traces shown in plot were made by using a peak detector and average detector.
- Deviations to the Specifications: None.

- Test plots

Test mode: (Neutral)

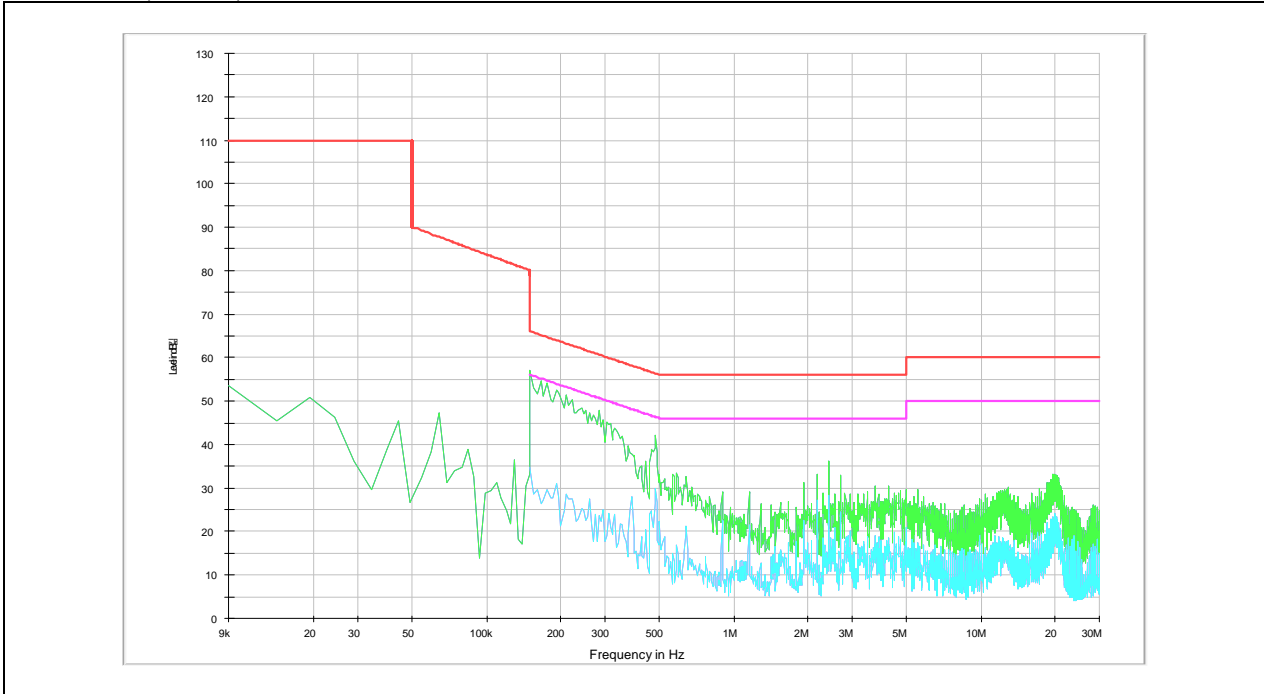

Test mode: (Hot)

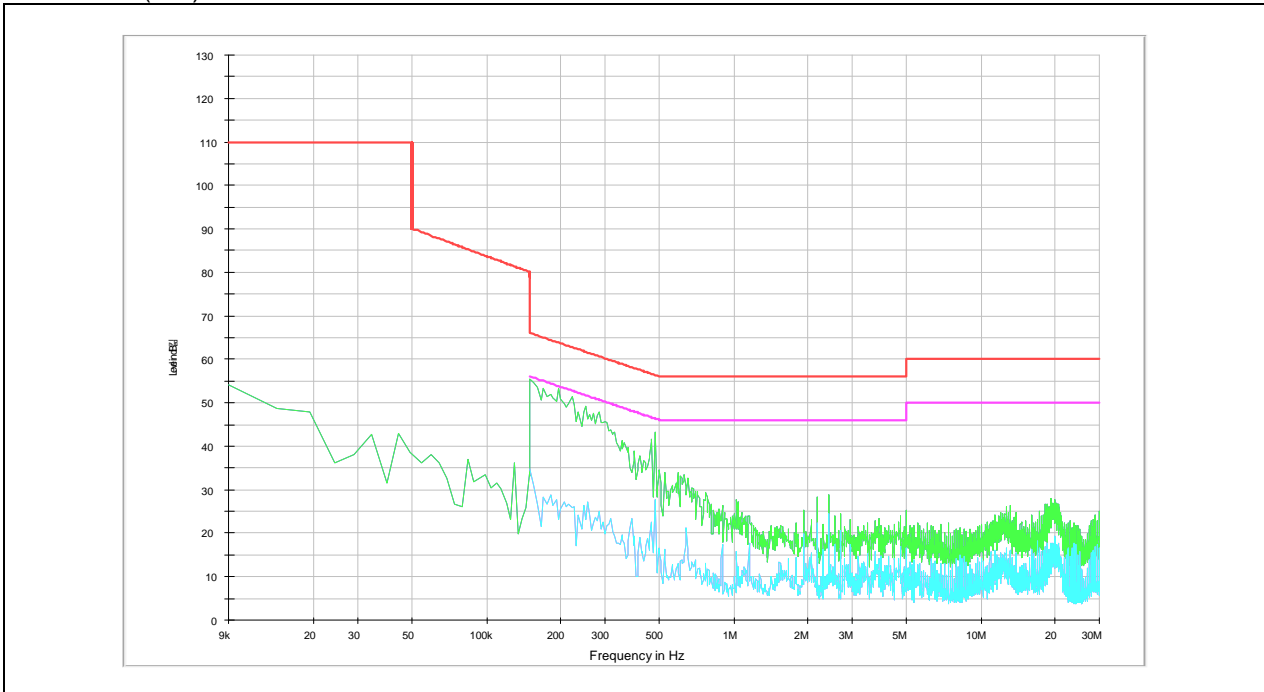

Test Condition: 2 W & 4.5W Operating mode with 3 client devices (1 % battery status of client device)

Ant. 1 (119 kHz ~ 122 kHz) & Ant. 6 (126.2 kHz ~ 129.2 kHz) & Ant. 7 (144.5 kHz ~ 147.5 kHz)

FREQ. (MHz)	LEVEL (dB μ V)		LINE	LIMIT (dB μ V)		MARGIN (dB)	
	Q-Peak	Average		Q-Peak	Average	Q-Peak	Average
0.16	52.80	36.30	N	65.46	55.46	12.66	19.16
0.20	49.40	28.30	N	63.61	53.61	14.21	25.31
0.46	36.80	24.90	N	56.69	46.69	19.89	21.79
2.48	31.60	26.20	N	56.00	46.00	24.40	19.80
19.70	30.70	22.90	N	60.00	50.00	29.30	27.10
27.58	30.30	25.40	N	60.00	50.00	29.70	24.60
0.16	51.80	33.00	H	65.46	55.46	13.66	22.46
0.19	49.70	28.10	H	64.04	54.04	14.34	25.94
0.48	40.80	25.90	H	56.34	46.34	15.54	20.44
1.02	24.30	20.50	H	56.00	46.00	31.70	25.50
19.12	22.30	15.50	H	60.00	50.00	37.70	34.50
27.87	28.50	24.10	H	60.00	50.00	31.50	25.90

Remark;

1. Line (H): Hot, Line (N): Neutral
2. Each charging mode with client device (1 %, 50 % and 99 % of battery) was tested. As worst condition, charging mode with client device (1 %) is reported.
3. The limit for Class B device(s) from 150 kHz to 30 MHz are specified in section of the Title 47 CFR.
4. Traces shown in plot were made by using a peak detector and average detector.
5. Deviations to the Specifications: None.

- Test plots

Test mode: (Neutral)

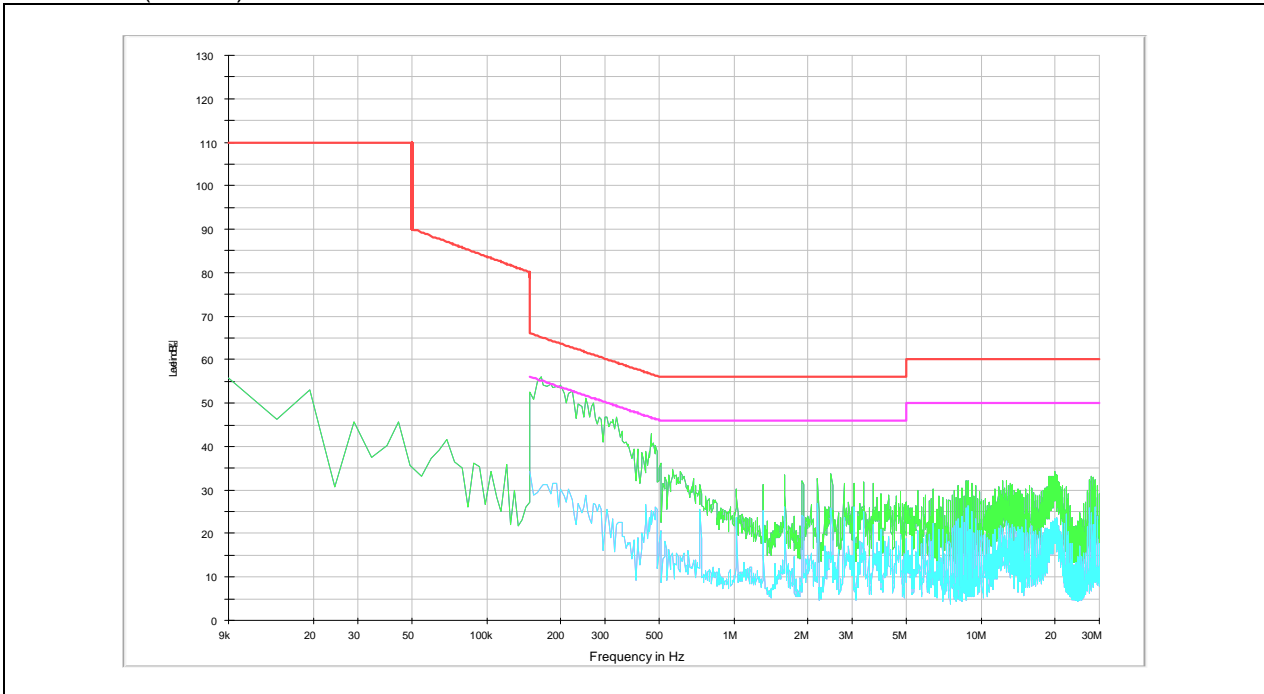

Test mode: (Hot)

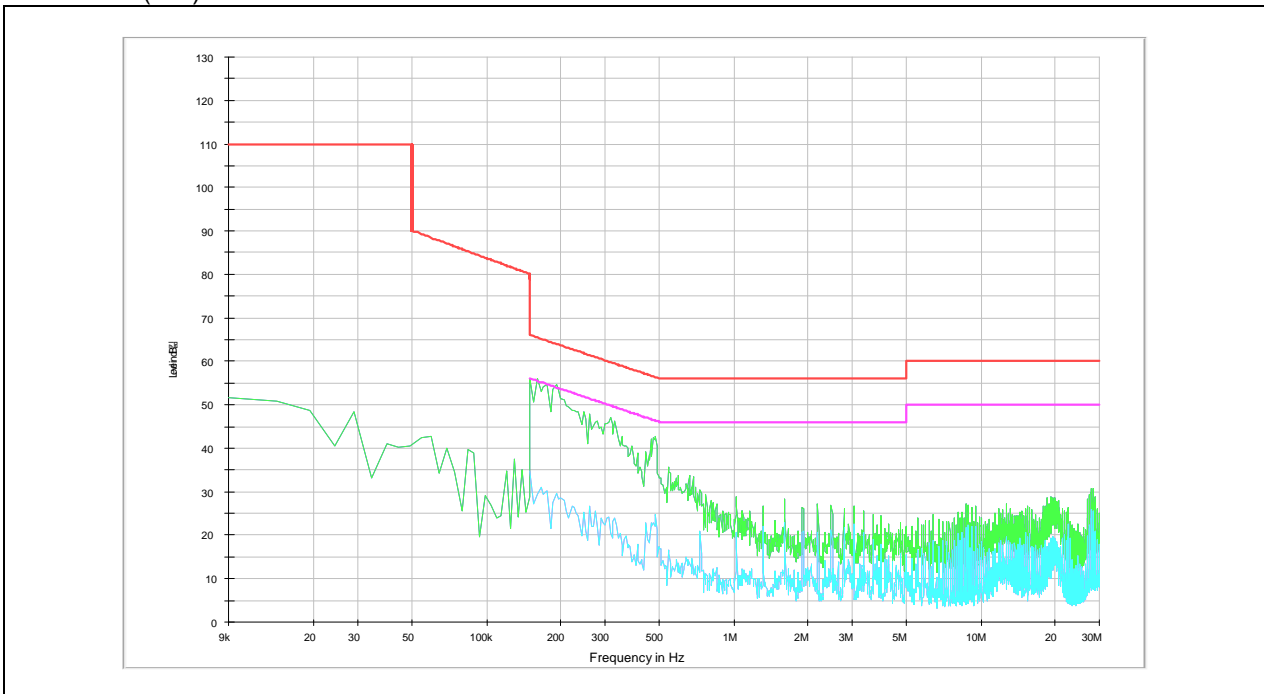

Test Condition: 2 W & 4.5W Operating mode with 3 client devices (1 % battery status of client device)

Ant. 1 (126.2 kHz ~ 129.2 kHz) & Ant. 6 (119 kHz ~ 122 kHz) & Ant. 7 (144.5 kHz ~ 147.5 kHz)

FREQ. (MHz)	LEVEL (dBμV)		LINE	LIMIT (dBμV)		MARGIN (dB)	
	Q-Peak	Average		Q-Peak	Average	Q-Peak	Average
0.15	51.50	33.50	N	66.00	56.00	14.50	22.50
0.23	46.00	25.10	N	62.45	52.45	16.45	27.35
0.48	38.10	29.60	N	56.34	46.34	18.24	16.74
2.49	26.30	20.60	N	56.00	46.00	29.70	25.40
12.12	24.40	17.50	N	60.00	50.00	35.60	32.50
19.80	28.80	21.40	N	60.00	50.00	31.20	28.60
0.16	51.20	30.30	H	65.46	55.46	14.26	25.16
0.24	46.60	24.90	H	62.10	52.10	15.50	27.20
0.48	40.10	27.80	H	56.34	46.34	16.24	18.54
2.48	24.20	21.90	H	56.00	46.00	31.80	24.10
11.68	18.60	13.00	H	60.00	50.00	41.40	37.00
19.34	21.30	16.10	H	60.00	50.00	38.70	33.90

Remark;

1. Line (H): Hot, Line (N): Neutral
2. Each charging mode with client device (1 %, 50 % and 99 % of battery) was tested.
As worst condition, charging mode with client device (1 %) is reported.
3. The limit for Class B device(s) from 150 kHz to 30 MHz are specified in section of the Title 47 CFR.
4. Traces shown in plot were made by using a peak detector and average detector.
5. Deviations to the Specifications: None.

- Test plots

Test mode: (Neutral)

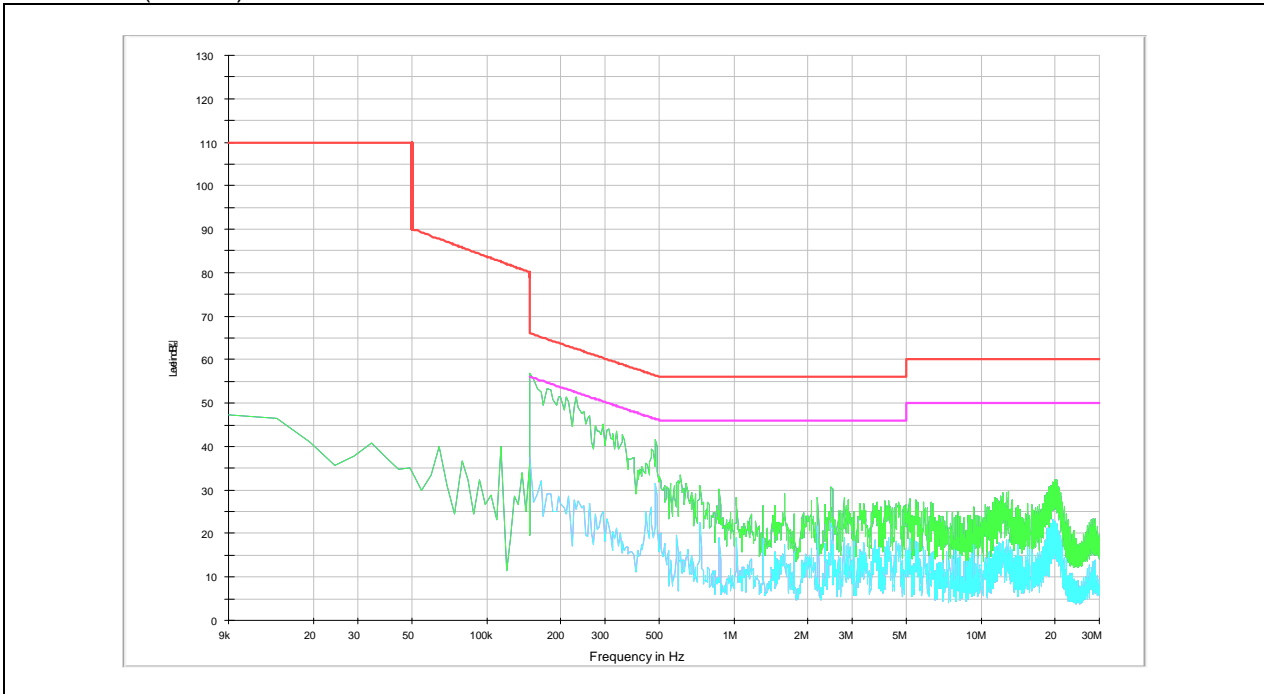

Test mode: (Hot)

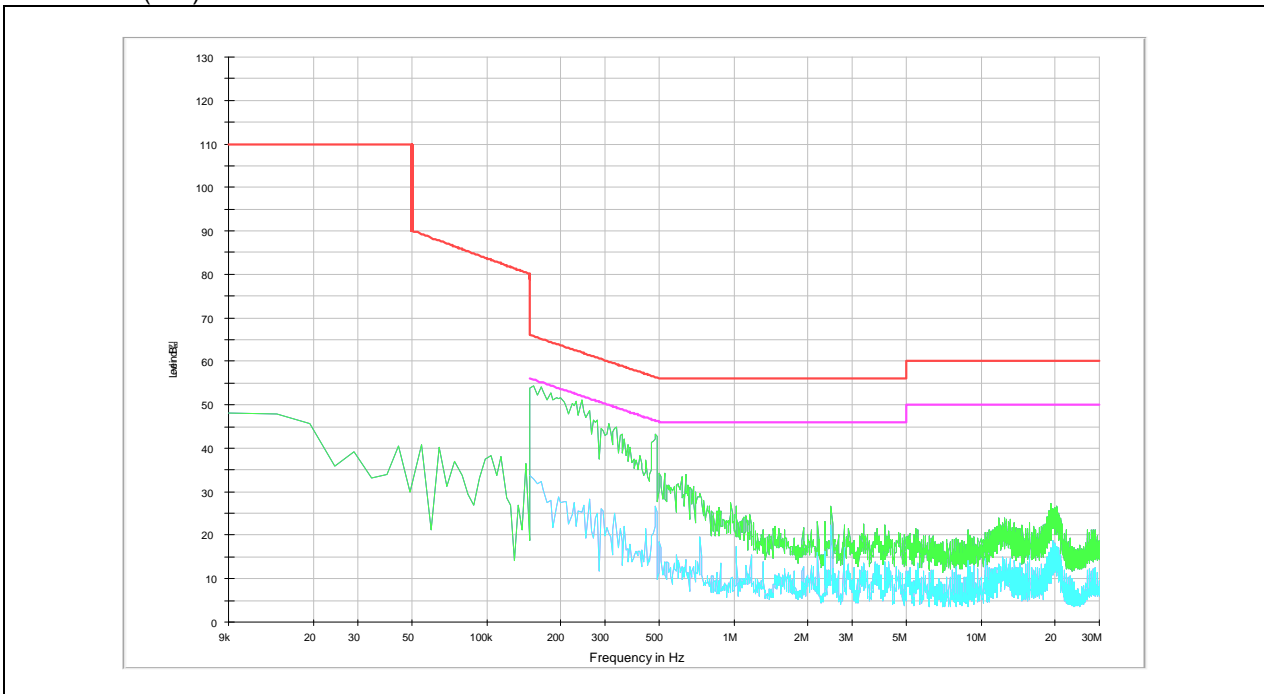

Test Condition: 2 W & 4.5W Operating mode with 3 client devices (1 % battery status of client device)

Ant. 1 (126.2 kHz ~ 129.2 kHz) & Ant. 6 (126.2 kHz ~ 129.2 kHz) & Ant. 7 (144.5 kHz ~ 147.5 kHz)

FREQ. (MHz)	LEVEL (dB μ V)		LINE	LIMIT (dB μ V)		MARGIN (dB)	
	Q-Peak	Average		Q-Peak	Average	Q-Peak	Average
0.15	52.30	33.00	N	66.00	56.00	13.70	23.00
0.20	47.10	27.10	N	63.61	53.61	16.51	26.51
0.46	32.40	24.40	N	56.69	46.69	24.29	22.29
2.49	25.80	19.40	N	56.00	46.00	30.20	26.60
12.25	22.90	16.20	N	60.00	50.00	37.10	33.80
19.86	27.80	20.50	N	60.00	50.00	32.20	29.50
0.16	51.00	29.80	H	65.46	55.46	14.46	25.66
0.31	41.70	22.30	H	59.97	49.97	18.27	27.67
0.48	39.90	26.80	H	56.34	46.34	16.44	19.54
2.48	22.60	19.40	H	56.00	46.00	33.40	26.60
11.97	17.60	12.20	H	60.00	50.00	42.40	37.80
19.74	21.10	15.20	H	60.00	50.00	38.90	34.80

Remark;

1. Line (H): Hot, Line (N): Neutral
2. Each charging mode with client device (1 %, 50 % and 99 % of battery) was tested. As worst condition, charging mode with client device (1 %) is reported.
3. The limit for Class B device(s) from 150 kHz to 30 MHz are specified in section of the Title 47 CFR.
4. Traces shown in plot were made by using a peak detector and average detector.
5. Deviations to the Specifications: None.

- Test plots

Test mode: (Neutral)

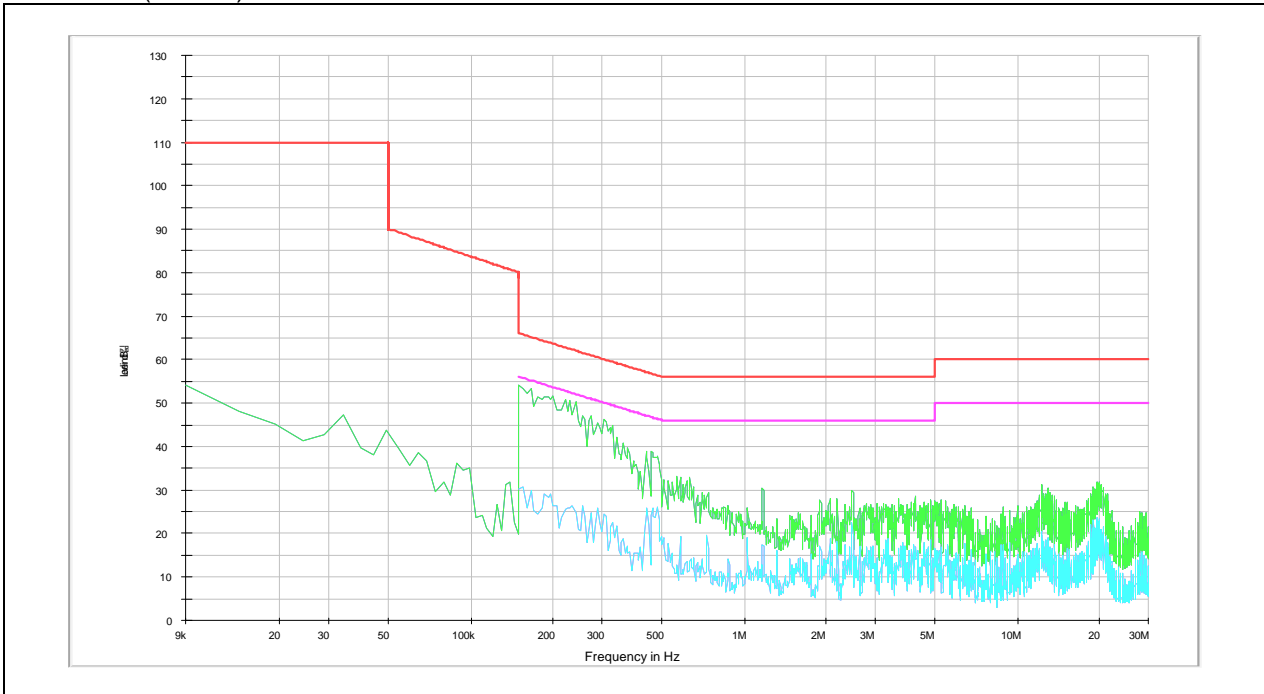

Test mode: (Hot)

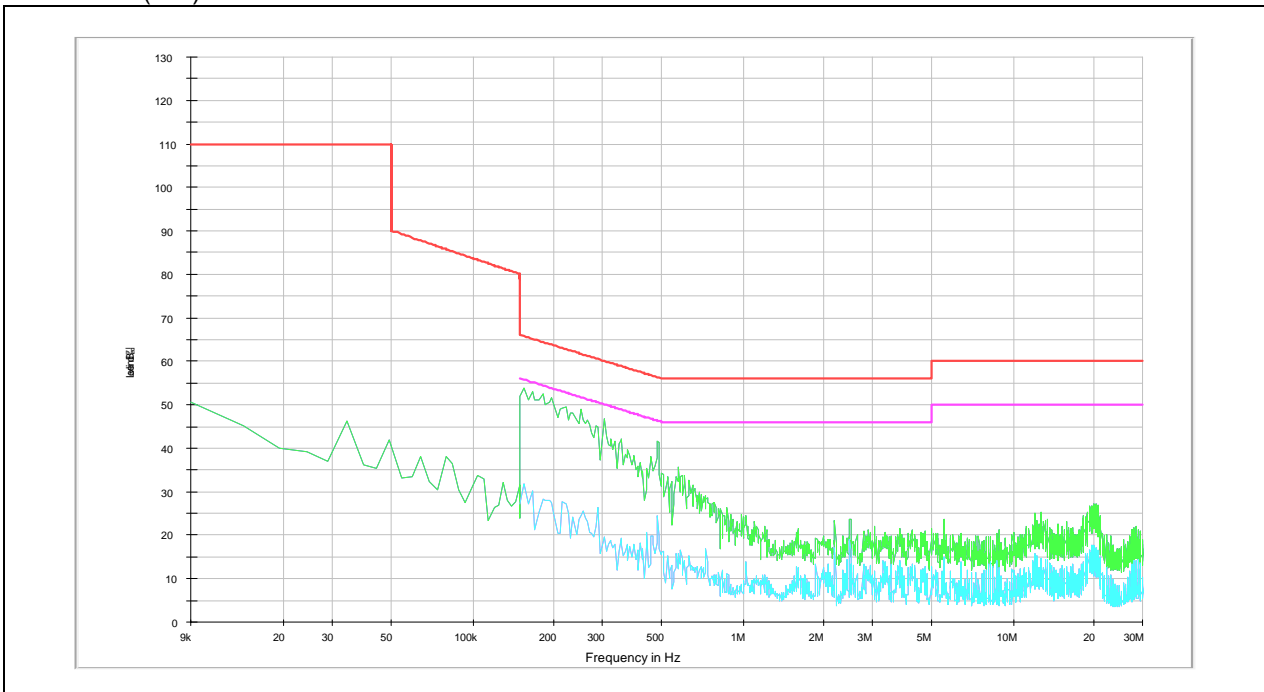

Test Condition: 2 W & 7.5W Operating mode with 3 client devices (1 % battery status of client device)

Ant. 1 (136.5 kHz ~ 139.5 kHz) & Ant. 6 (144.5 kHz ~ 147.5 kHz) & Ant. 7 (144.5 kHz ~ 147.5 kHz)

FREQ. (MHz)	LEVEL (dB μ V)		LINE	LIMIT (dB μ V)		MARGIN (dB)	
	Q-Peak	Average		Q-Peak	Average	Q-Peak	Average
0.17	45.10	25.90	N	64.96	54.96	19.86	29.06
0.19	44.30	23.90	N	64.04	54.04	19.74	30.14
0.38	35.60	19.20	N	58.28	48.28	22.68	29.08
2.35	34.00	28.40	N	56.00	46.00	22.00	17.60
4.83	28.90	21.30	N	56.00	46.00	27.10	24.70
19.11	31.10	18.90	N	60.00	50.00	28.90	31.10
0.16	47.70	24.80	H	65.46	55.46	17.76	30.66
0.20	46.30	24.40	H	63.61	53.61	17.31	29.21
0.48	34.70	21.60	H	56.34	46.34	21.64	24.74
5.02	21.40	14.50	H	60.00	50.00	38.60	35.50
10.21	22.50	15.40	H	60.00	50.00	37.50	34.60
18.04	26.70	16.80	H	60.00	50.00	33.30	33.20

Remark;

1. Line (H): Hot, Line (N): Neutral
2. Each charging mode with client device (1 %, 50 % and 99 % of battery) was tested.
As worst condition, charging mode with client device (1 %) is reported.
3. The limit for Class B device(s) from 150 kHz to 30 MHz are specified in section of the Title 47 CFR.
4. Traces shown in plot were made by using a peak detector and average detector.
5. Deviations to the Specifications: None.

- Test plots

Test mode: (Neutral)

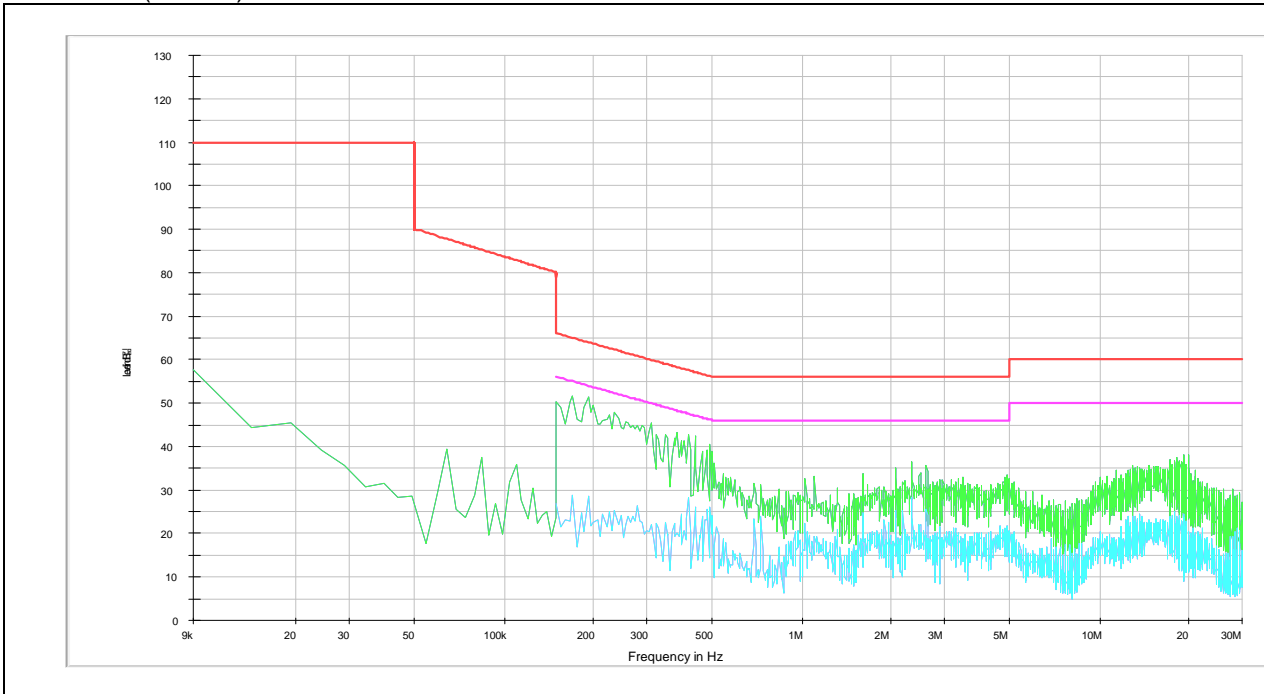

Test mode: (Hot)

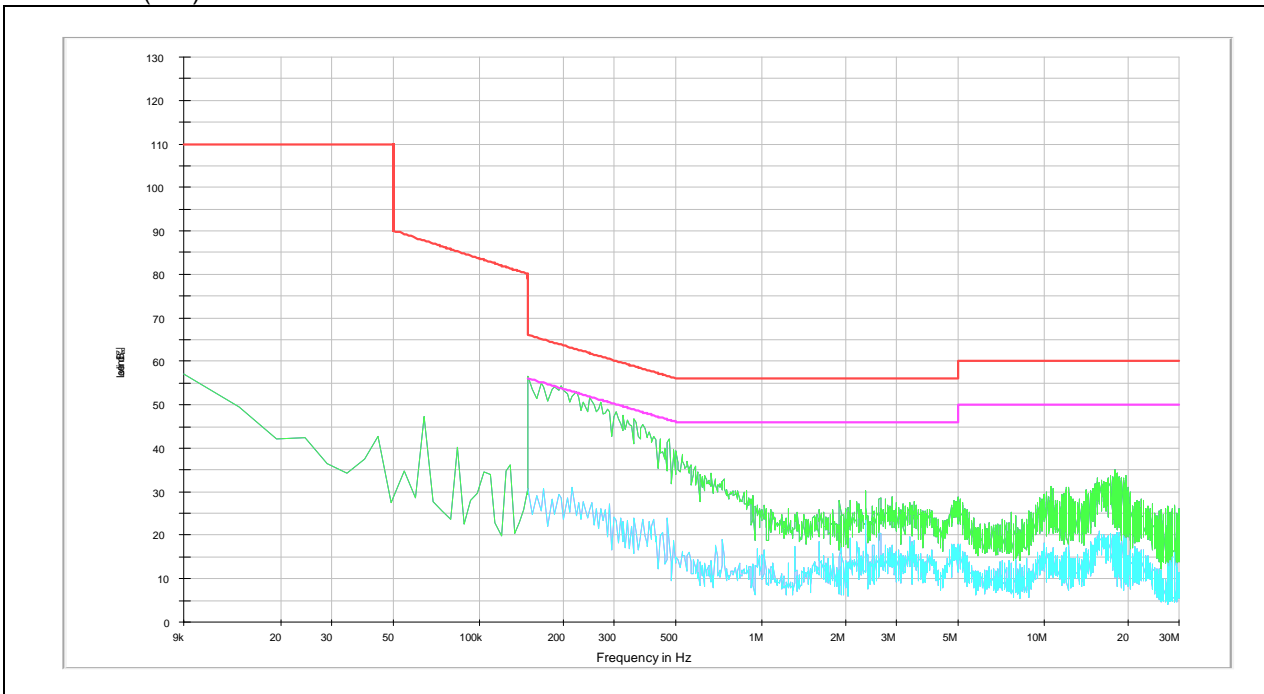

Ant. 1 (136.5 kHz ~ 139.5 kHz) & Ant. 6 (126.2 kHz ~ 129.2 kHz) & Ant. 7 (144.5 kHz ~ 147.5 kHz)

FREQ. (MHz)	LEVEL (dB μ V)		LINE	LIMIT (dB μ V)		MARGIN (dB)	
	Q-Peak	Average		Q-Peak	Average	Q-Peak	Average
0.16	49.30	30.20	N	65.46	55.46	16.16	25.26
0.22	46.10	26.90	N	62.82	52.82	16.72	25.92
0.32	41.50	26.40	N	59.71	49.71	18.21	23.31
0.43	41.90	32.80	N	57.25	47.25	15.35	14.45
5.26	36.10	27.60	N	60.00	50.00	23.90	22.40
20.05	40.30	31.30	N	60.00	50.00	19.70	18.70
0.16	49.20	28.70	H	65.46	55.46	16.26	26.76
0.24	40.70	21.70	H	62.10	52.10	21.40	30.40
0.33	40.90	23.10	H	59.45	49.45	18.55	26.35
2.90	30.60	24.00	H	56.00	46.00	25.40	22.00
11.44	31.50	21.50	H	60.00	50.00	28.50	28.50
17.82	39.20	32.00	H	60.00	50.00	20.80	18.00

Remark;

- Line (H): Hot, Line (N): Neutral
- Each charging mode with client device (1 %, 50 % and 99 % of battery) was tested. As worst condition, charging mode with client device (1 %) is reported.
- The limit for Class B device(s) from 150 kHz to 30 MHz are specified in section of the Title 47 CFR.
- Traces shown in plot were made by using a peak detector and average detector.
- Deviations to the Specifications: None.

- Test plots

Test mode: (Neutral)

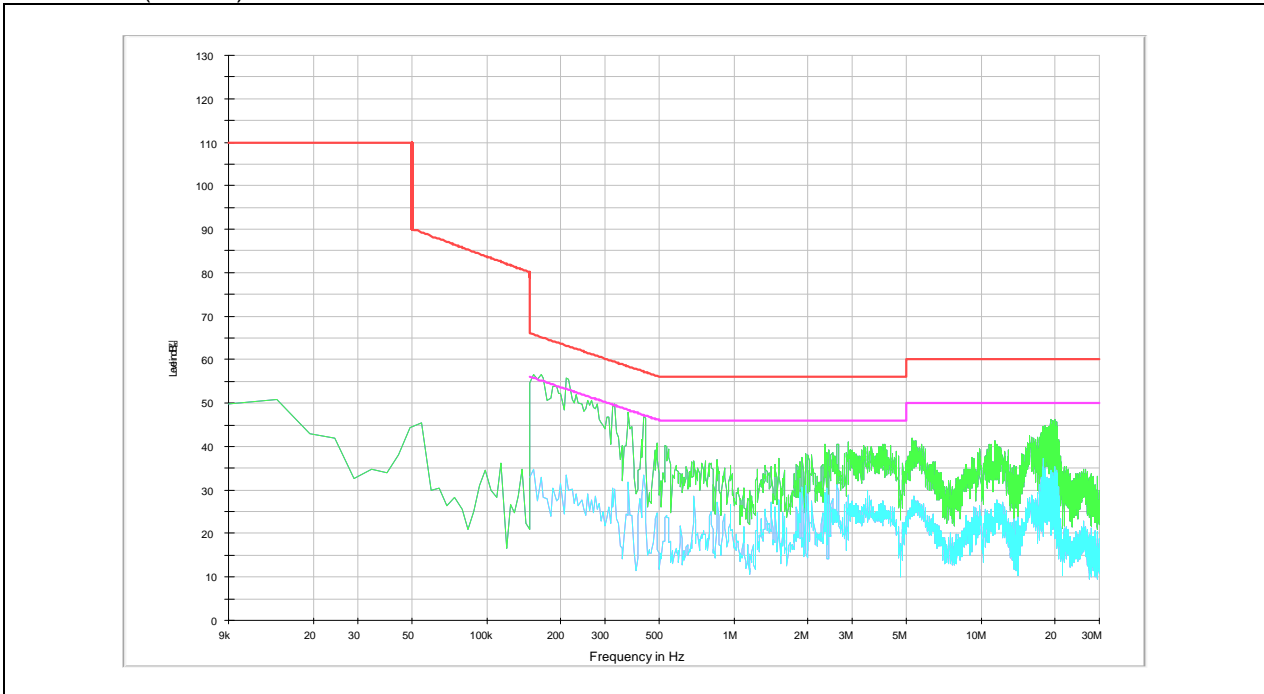

Test mode: (Hot)

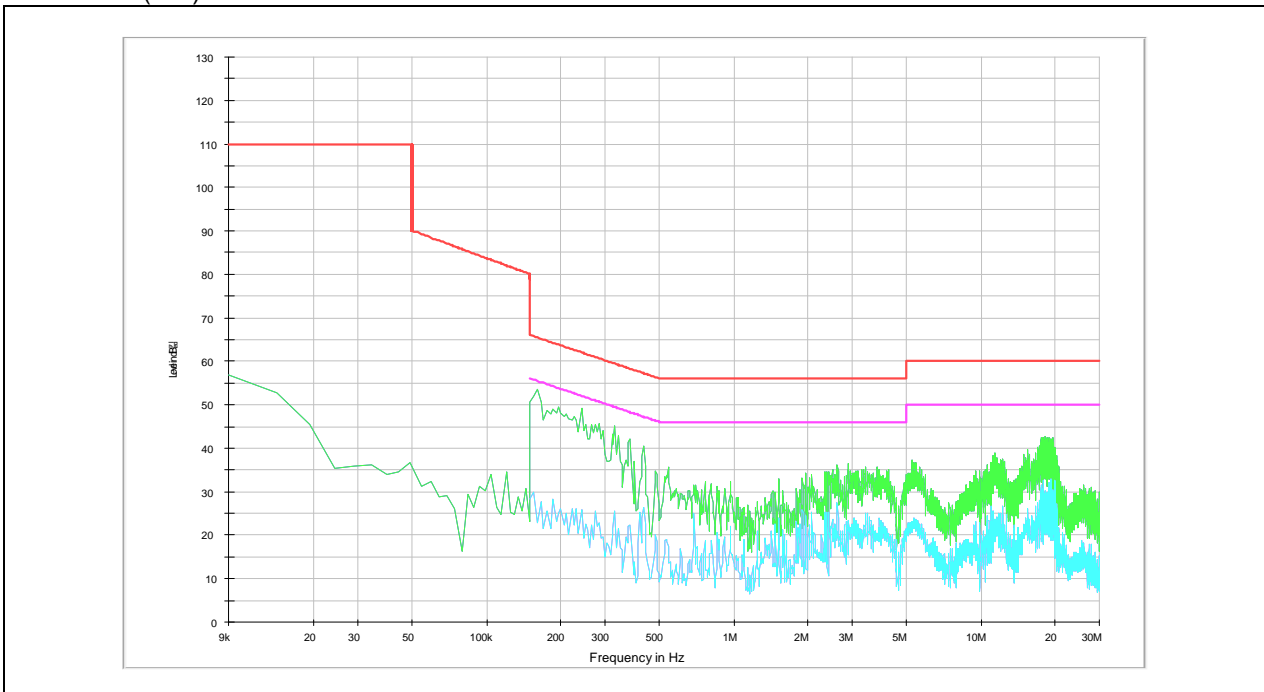

Ant. 1 (126.2 kHz ~ 129.2 kHz) & Ant. 6 (144.5 kHz ~ 147.5 kHz) & Ant. 7 (144.5 kHz ~ 147.5 kHz)

FREQ. (MHz)	LEVEL (dB μ V)		LINE	LIMIT (dB μ V)		MARGIN (dB)	
	Q-Peak	Average		Q-Peak	Average	Q-Peak	Average
0.19	42.50	31.20	N	64.04	54.04	21.54	22.84
0.29	38.90	26.80	N	60.52	50.52	21.62	23.72
0.44	38.70	32.30	N	57.06	47.06	18.36	14.76
5.20	36.60	27.40	N	60.00	50.00	23.40	22.60
10.94	36.80	24.30	N	60.00	50.00	23.20	25.70
18.51	40.70	31.00	N	60.00	50.00	19.30	19.00
0.16	40.40	21.20	H	65.46	55.46	25.06	34.26
0.22	39.00	21.00	H	62.82	52.82	23.82	31.82
0.33	35.20	19.60	H	59.45	49.45	24.25	29.85
5.35	29.50	22.20	H	60.00	50.00	30.50	27.80
11.32	29.10	20.80	H	60.00	50.00	30.90	29.20
18.48	35.40	26.80	H	60.00	50.00	24.60	23.20

Remark;

- Line (H): Hot, Line (N): Neutral
- Each charging mode with client device (1 %, 50 % and 99 % of battery) was tested. As worst condition, charging mode with client device (1 %) is reported.
- The limit for Class B device(s) from 150 kHz to 30 MHz are specified in section of the Title 47 CFR.
- Traces shown in plot were made by using a peak detector and average detector.
- Deviations to the Specifications: None.

- Test plots

Test mode: (Neutral)

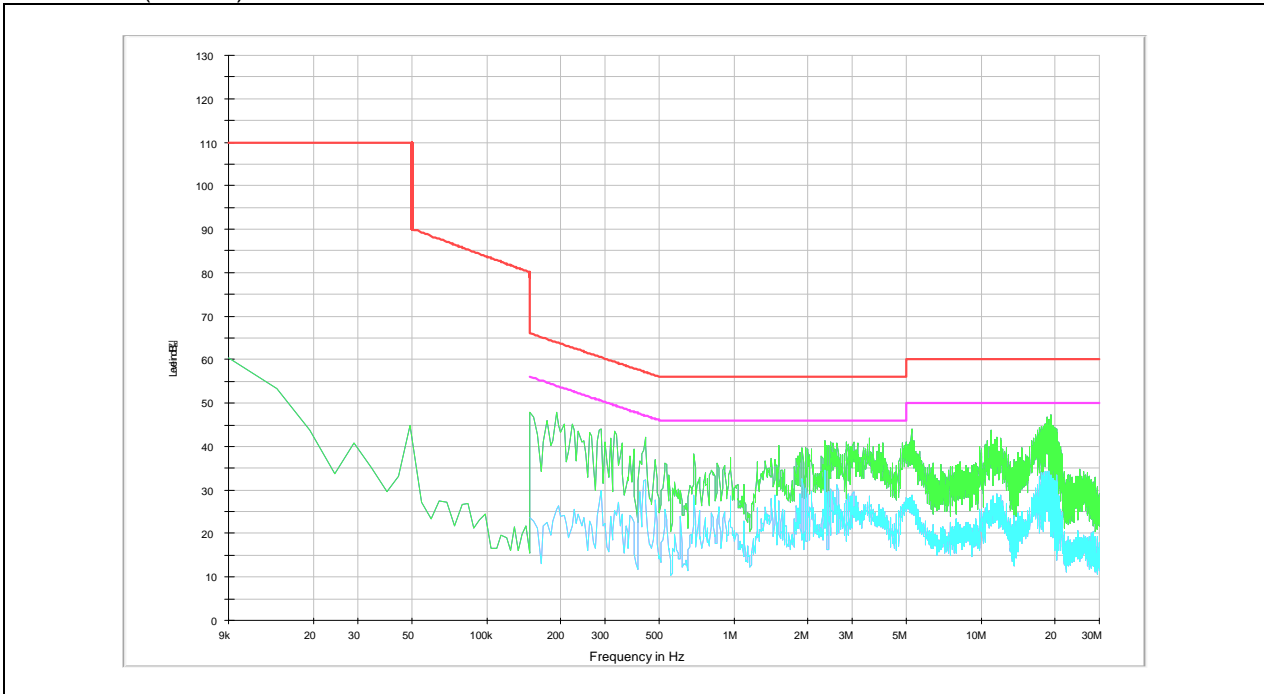

Test mode: (Hot)

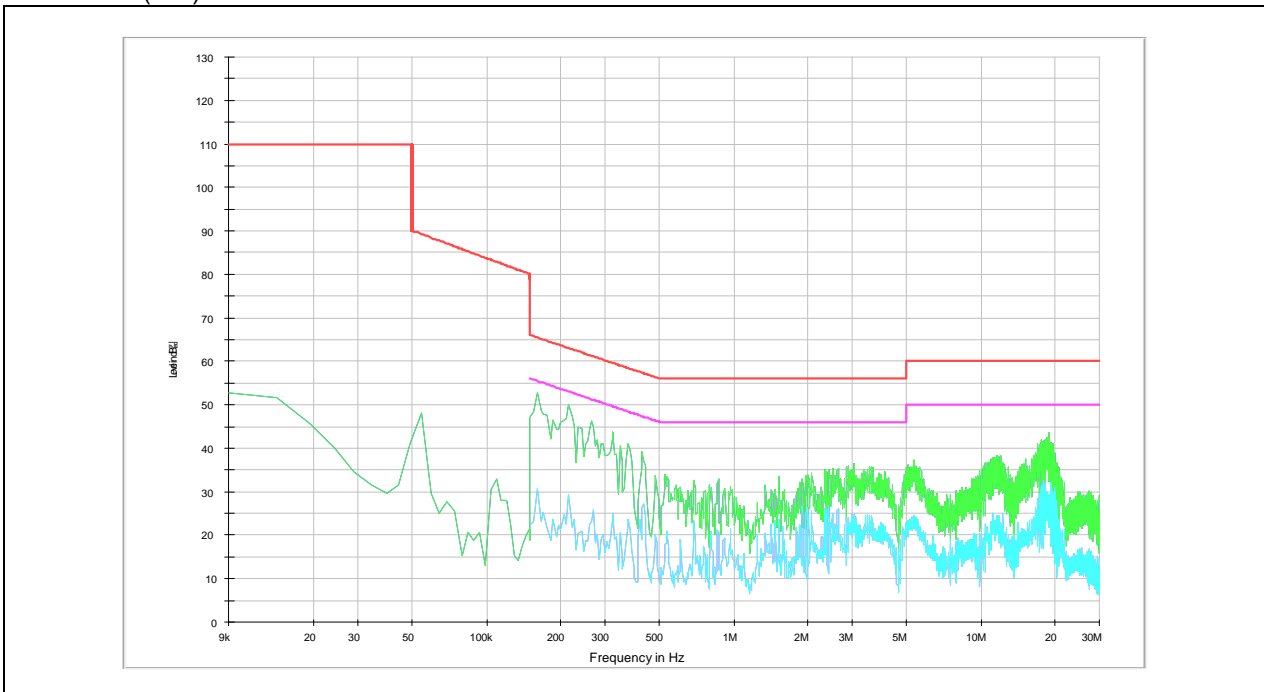

Ant. 1 (126.2 kHz ~ 129.2 kHz) & Ant. 6 (126.2 kHz ~ 129.2 kHz) & Ant. 7 (144.5 kHz ~ 147.5 kHz)

FREQ. (MHz)	LEVEL (dB μ V)		LINE	LIMIT (dB μ V)		MARGIN (dB)	
	Q-Peak	Average		Q-Peak	Average	Q-Peak	Average
0.20	42.40	27.10	N	63.61	53.61	21.21	26.51
0.24	41.10	26.20	N	62.10	52.10	21.00	25.90
0.33	37.50	25.30	N	59.45	49.45	21.95	24.15
5.15	36.30	27.50	N	60.00	50.00	23.70	22.50
11.00	36.90	25.40	N	60.00	50.00	23.10	24.60
18.57	42.90	32.20	N	60.00	50.00	17.10	17.80
0.16	38.00	18.70	H	65.46	55.46	27.46	36.76
0.21	35.90	18.10	H	63.21	53.21	27.31	35.11
0.29	31.60	16.10	H	60.52	50.52	28.92	34.42
2.62	27.90	22.00	H	56.00	46.00	28.10	24.00
11.58	25.00	16.50	H	60.00	50.00	35.00	33.50
18.32	31.10	24.00	H	60.00	50.00	28.90	26.00

Remark;

- Line (H): Hot, Line (N): Neutral
- Each charging mode with client device (1 %, 50 % and 99 % of battery) was tested. As worst condition, charging mode with client device (1 %) is reported.
- The limit for Class B device(s) from 150 kHz to 30 MHz are specified in section of the Title 47 CFR.
- Traces shown in plot were made by using a peak detector and average detector.
- Deviations to the Specifications: None.

- Test plots

Test mode: (Neutral)

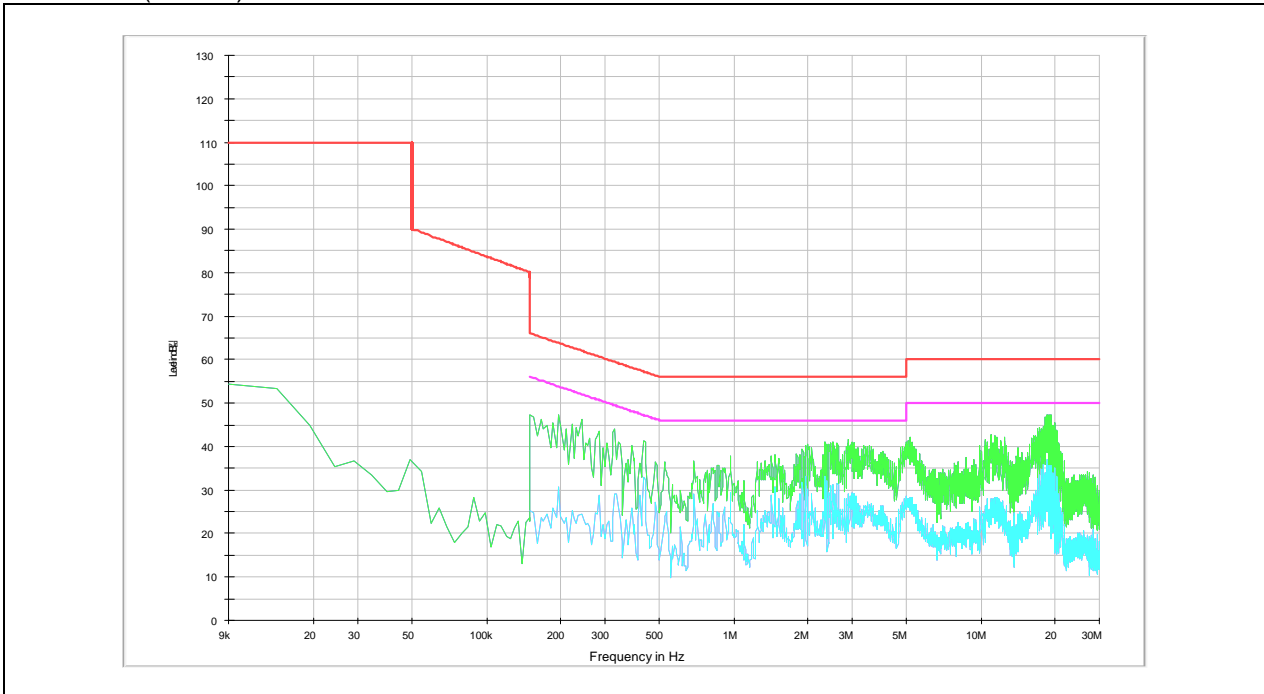

Test mode: (Hot)

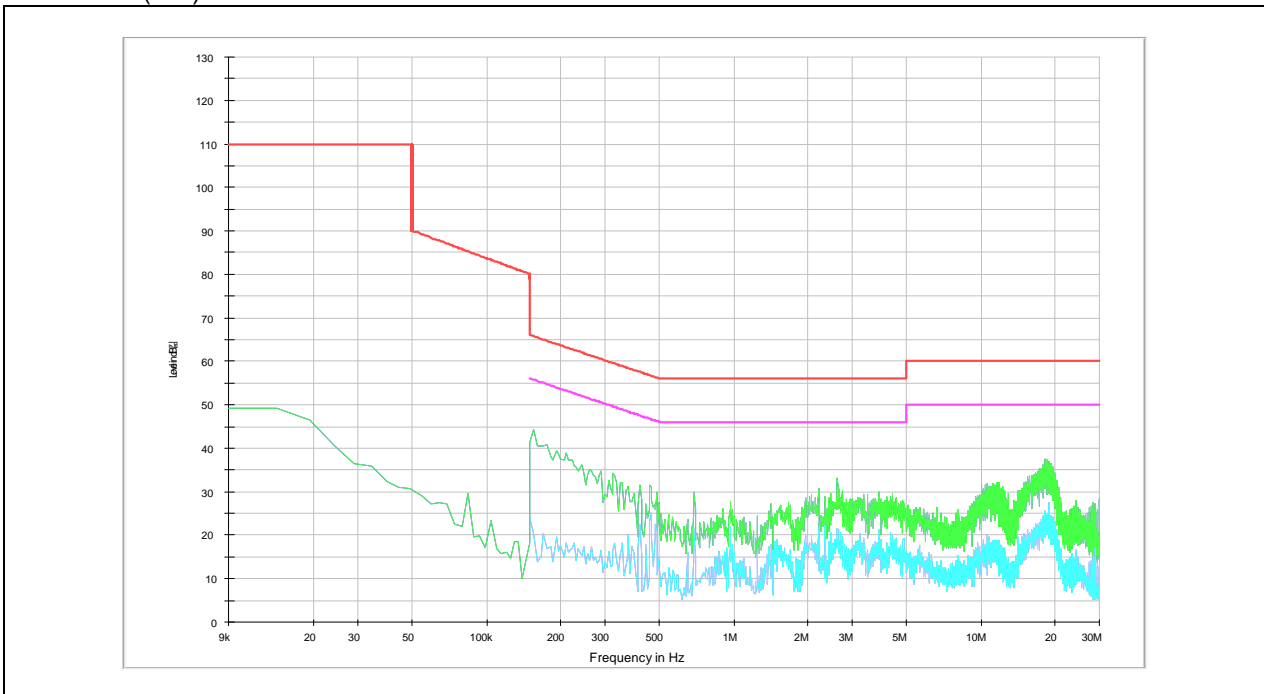

Test Condition: 2 W & 9W Operating mode with 3 client devices (1 % battery status of client device)

Ant. 1 (136.5 kHz ~ 139.5 kHz) & Ant. 6 (144.5 kHz ~ 147.5 kHz) & Ant. 7 (144.5 kHz ~ 147.5 kHz)

FREQ. (MHz)	LEVEL (dB μ V)		LINE	LIMIT (dB μ V)		MARGIN (dB)	
	Q-Peak	Average		Q-Peak	Average	Q-Peak	Average
0.17	52.60	41.90	N	64.96	54.96	12.36	13.06
0.19	50.50	31.10	N	64.04	54.04	13.54	22.94
0.46	41.70	30.90	N	56.69	46.69	14.99	15.79
3.02	27.30	20.40	N	56.00	46.00	28.70	25.60
5.26	29.90	19.30	N	60.00	50.00	30.10	30.70
12.78	35.60	26.80	N	60.00	50.00	24.40	23.20
0.17	54.60	41.60	H	64.96	54.96	10.36	13.36
0.19	52.30	33.50	H	64.04	54.04	11.74	20.54
0.46	39.10	26.50	H	56.69	46.69	17.59	20.19
2.05	20.40	15.80	H	56.00	46.00	35.60	30.20
5.11	23.30	16.20	H	60.00	50.00	36.70	33.80
12.64	29.50	23.20	H	60.00	50.00	30.50	26.80

Remark;

- Line (H): Hot, Line (N): Neutral
- Each charging mode with client device (1 %, 50 % and 99 % of battery) was tested.
As worst condition, charging mode with client device (1 %) is reported.
- The limit for Class B device(s) from 150 kHz to 30 MHz are specified in section of the Title 47 CFR.
- Traces shown in plot were made by using a peak detector and average detector.
- Deviations to the Specifications: None.

- Test plots

Test mode: (Neutral)

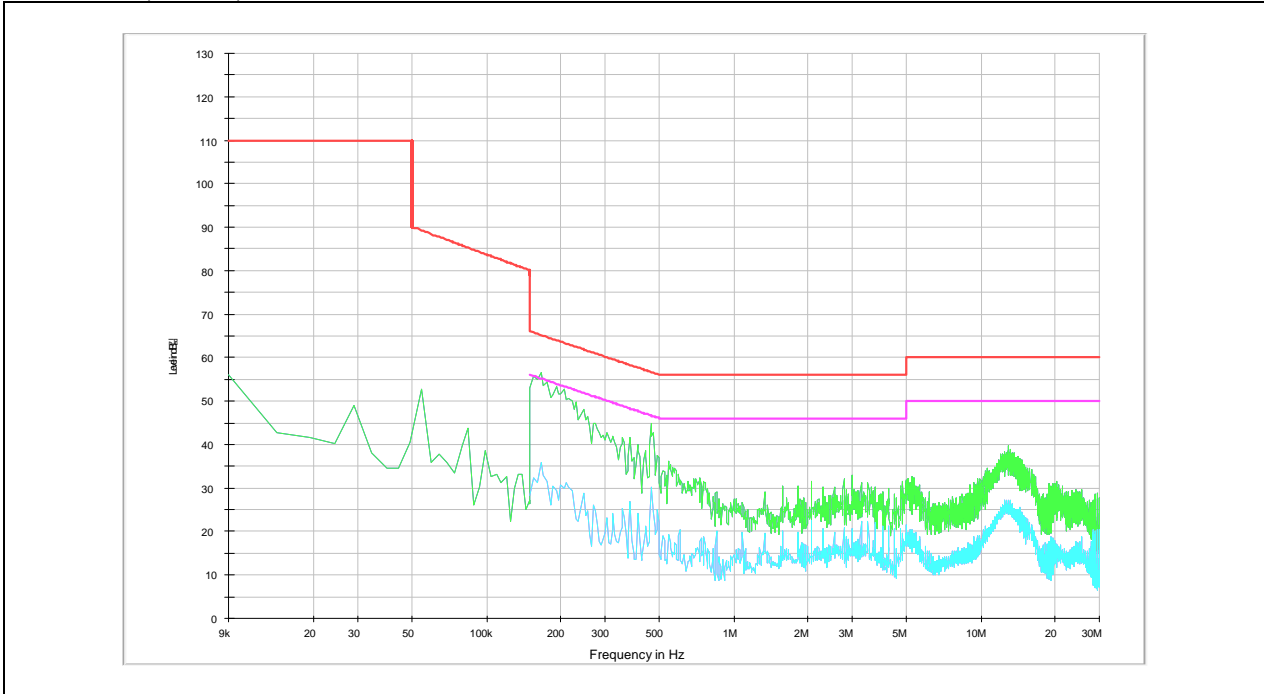

Test mode: (Hot)

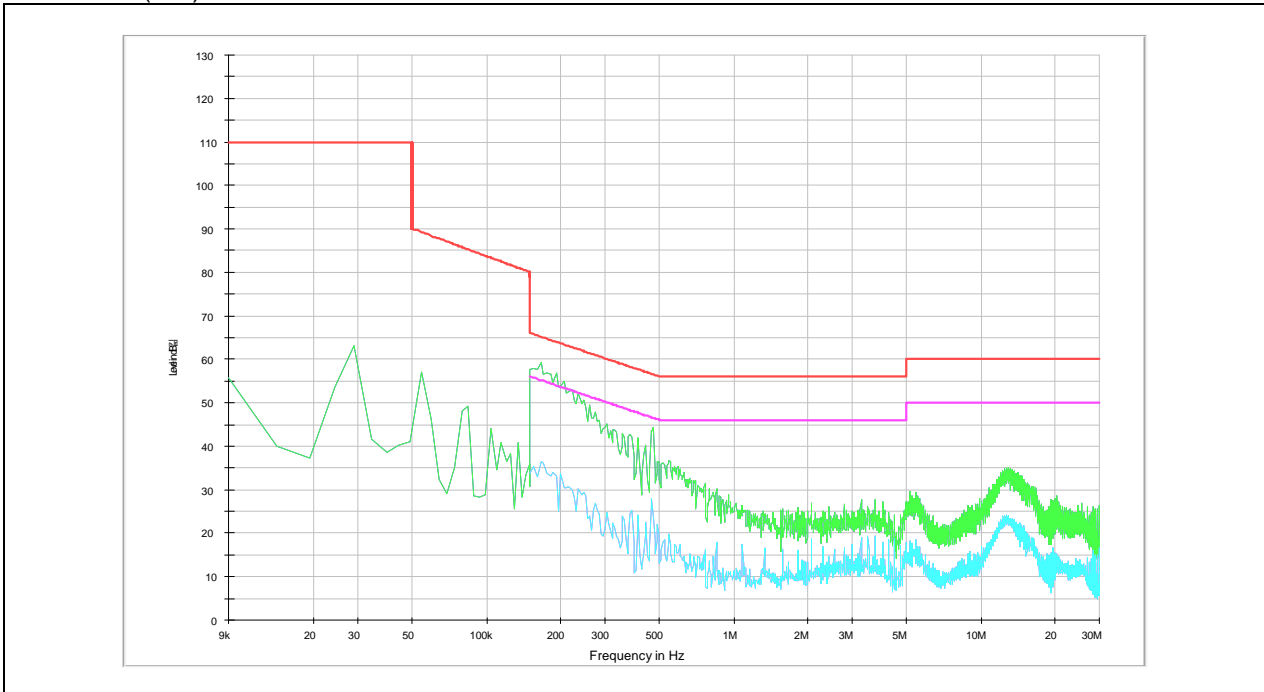

Test Condition: 2 W & 4.5W & 9W Operating mode with 3 client devices (1 % battery status of client device)

Ant. 1 (136.5 kHz ~ 139.5 kHz) & Ant. 6 (119 kHz ~ 122 kHz) & Ant. 7 (144.5 kHz ~ 147.5 kHz)

FREQ. (MHz)	LEVEL (dB μ V)		LINE	LIMIT (dB μ V)		MARGIN (dB)	
	Q-Peak	Average		Q-Peak	Average	Q-Peak	Average
0.15	51.60	39.60	N	66.00	56.00	14.40	16.40
0.17	49.10	30.50	N	64.96	54.96	15.86	24.46
0.46	40.60	29.80	N	56.69	46.69	16.09	16.89
1.81	24.30	17.80	N	56.00	46.00	31.70	28.20
5.00	28.00	19.00	N	56.00	46.00	28.00	27.00
12.83	35.30	26.40	N	60.00	50.00	24.70	23.60
0.16	53.10	38.40	H	65.46	55.46	12.36	17.06
0.21	46.70	28.40	H	63.21	53.21	16.51	24.81
0.37	37.40	23.20	H	58.50	48.50	21.10	25.30
0.47	38.60	28.80	H	56.51	46.51	17.91	17.71
5.21	24.50	15.60	H	60.00	50.00	35.50	34.40
13.16	29.10	23.00	H	60.00	50.00	30.90	27.00

Remark;

1. Line (H): Hot, Line (N): Neutral
2. Each charging mode with client device (1 %, 50 % and 99 % of battery) was tested.
As worst condition, charging mode with client device (1 %) is reported.
3. The limit for Class B device(s) from 150 kHz to 30 MHz are specified in section of the Title 47 CFR.
4. Traces shown in plot were made by using a peak detector and average detector.
5. Deviations to the Specifications: None.

- Test plots

Test mode: (Neutral)

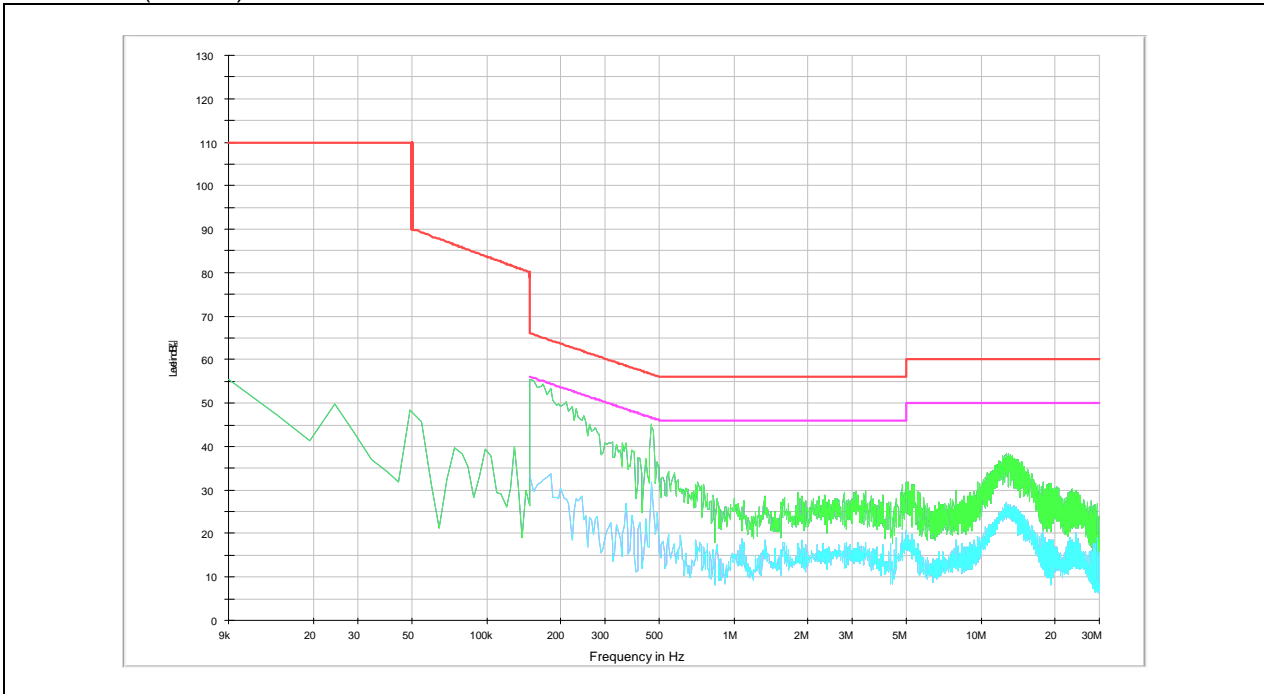

Test mode: (Hot)

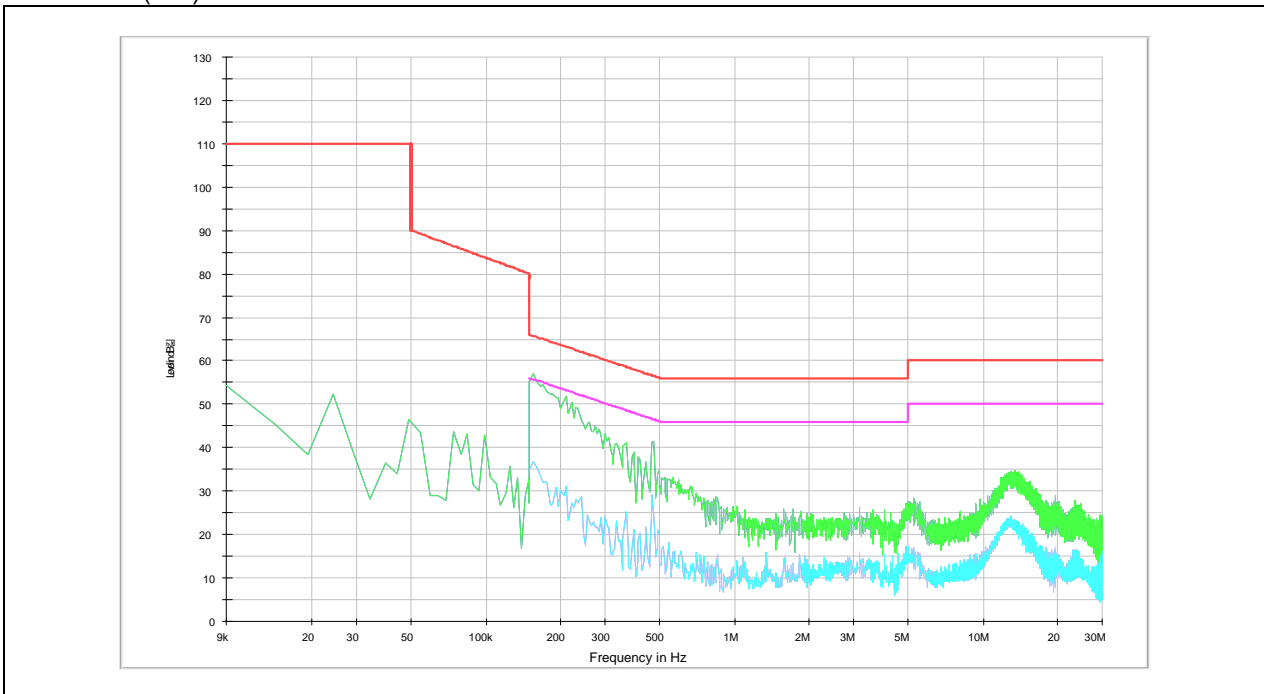

Ant. 1 (136.5 kHz ~ 139.5 kHz) & Ant. 6 (126.2 kHz ~ 129.2 kHz) & Ant. 7 (144.5 kHz ~ 147.5 kHz)

FREQ. (MHz)	LEVEL (dB μ V)		LINE	LIMIT (dB μ V)		MARGIN (dB)	
	Q-Peak	Average		Q-Peak	Average	Q-Peak	Average
0.18	49.90	29.00	N	64.49	54.49	14.59	25.49
0.48	37.30	27.80	N	56.34	46.34	19.04	18.54
2.07	32.50	27.20	N	56.00	46.00	23.50	18.80
12.42	27.20	20.80	N	60.00	50.00	32.80	29.20
19.74	31.80	25.10	N	60.00	50.00	28.20	24.90
28.29	30.50	24.00	N	60.00	50.00	29.50	26.00
0.20	48.20	32.20	H	63.61	53.61	15.41	21.41
0.34	39.30	20.90	H	59.20	49.20	19.90	28.30
0.48	39.90	25.90	H	56.34	46.34	16.44	20.44
2.90	26.20	22.90	H	56.00	46.00	29.80	23.10
19.37	23.80	18.10	H	60.00	50.00	36.20	31.90
28.57	27.90	23.20	H	60.00	50.00	32.10	26.80

Remark;

1. Line (H): Hot, Line (N): Neutral
2. Each charging mode with client device (1 %, 50 % and 99 % of battery) was tested. As worst condition, charging mode with client device (1 %) is reported.
3. The limit for Class B device(s) from 150 kHz to 30 MHz are specified in section of the Title 47 CFR.
4. Traces shown in plot were made by using a peak detector and average detector.
5. Deviations to the Specifications: None.

- Test plots

Test mode: (Neutral)

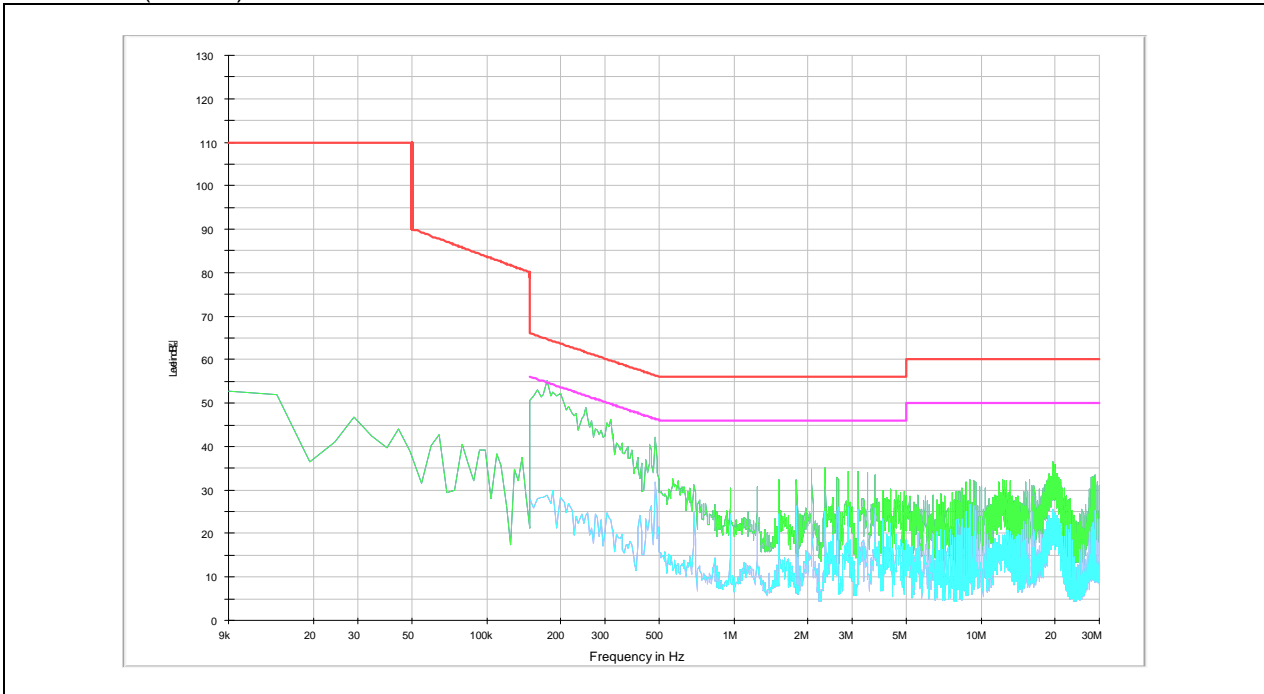

Test mode: (Hot)

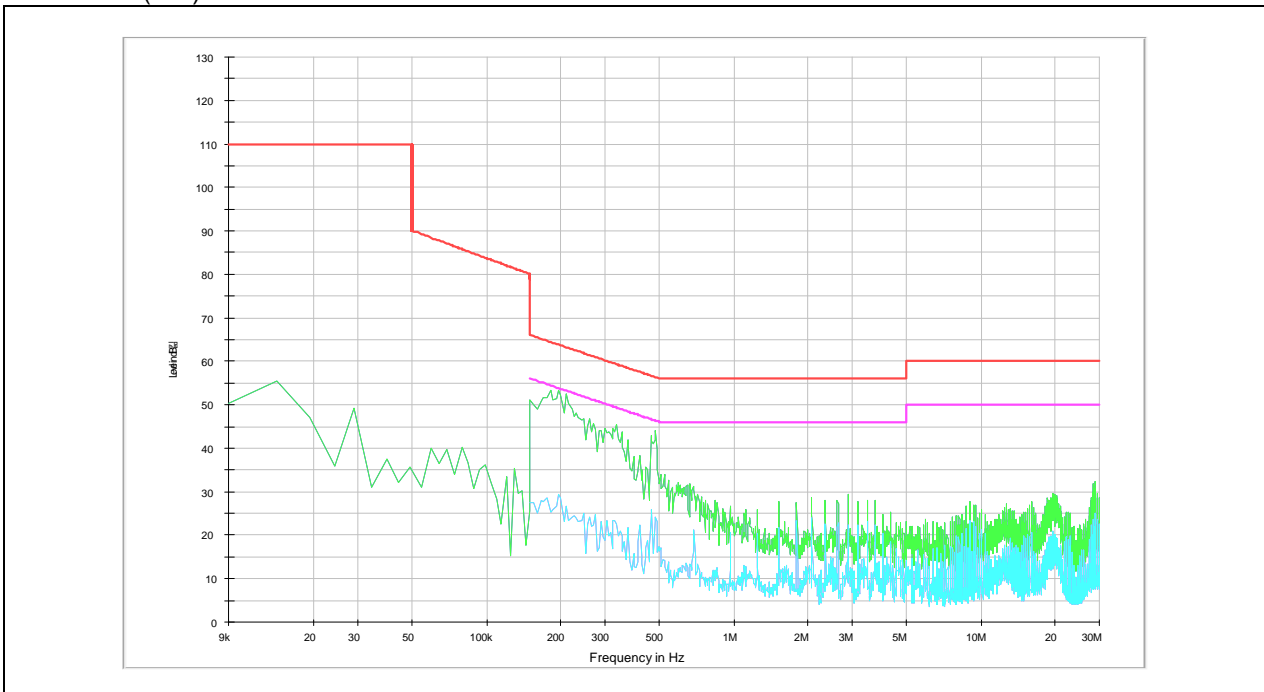

Ant. 1 (119 kHz ~ 122 kHz) & Ant. 6 (144.5 kHz ~ 147.5 kHz) & Ant. 7 (144.5 kHz ~ 147.5 kHz)

FREQ. (MHz)	LEVEL (dB μ V)		LINE	LIMIT (dB μ V)		MARGIN (dB)	
	Q-Peak	Average		Q-Peak	Average	Q-Peak	Average
0.16	50.60	30.80	N	65.46	55.46	14.86	24.66
0.18	50.00	30.10	N	64.49	54.49	14.49	24.39
0.47	35.60	26.70	N	56.51	46.51	20.91	19.81
2.29	32.30	27.20	N	56.00	46.00	23.70	18.80
12.42	26.00	19.00	N	60.00	50.00	34.00	31.00
19.50	28.00	21.30	N	60.00	50.00	32.00	28.70
0.18	50.10	30.30	H	64.49	54.49	14.39	24.19
0.47	37.80	22.70	H	56.51	46.51	18.71	23.81
0.59	28.90	13.70	H	56.00	46.00	27.10	32.30
4.95	19.20	15.20	H	56.00	46.00	36.80	30.80
12.91	17.10	12.70	H	60.00	50.00	42.90	37.30
19.72	22.60	16.40	H	60.00	50.00	37.40	33.60

Remark;

1. Line (H): Hot, Line (N): Neutral
2. Each charging mode with client device (1 %, 50 % and 99 % of battery) was tested.
As worst condition, charging mode with client device (1 %) is reported.
3. The limit for Class B device(s) from 150 kHz to 30 MHz are specified in section of the Title 47 CFR.
4. Traces shown in plot were made by using a peak detector and average detector.
5. Deviations to the Specifications: None.

- Test plots

Test mode: (Neutral)

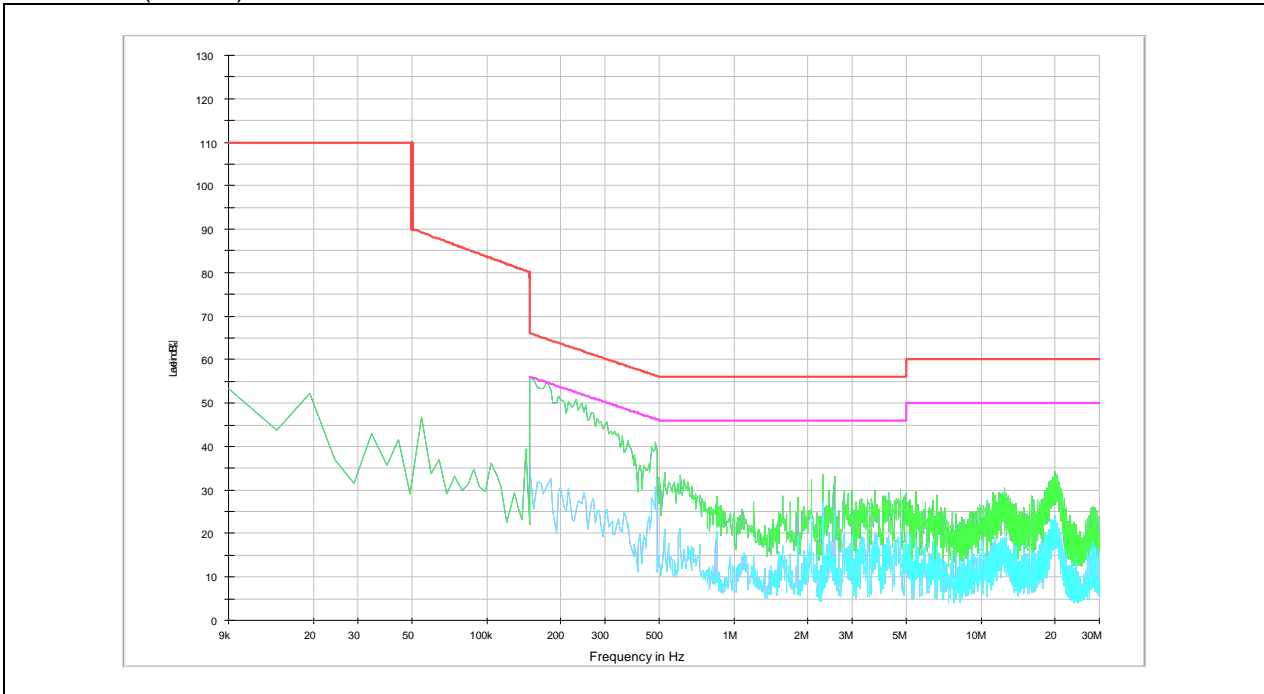

Test mode: (Hot)

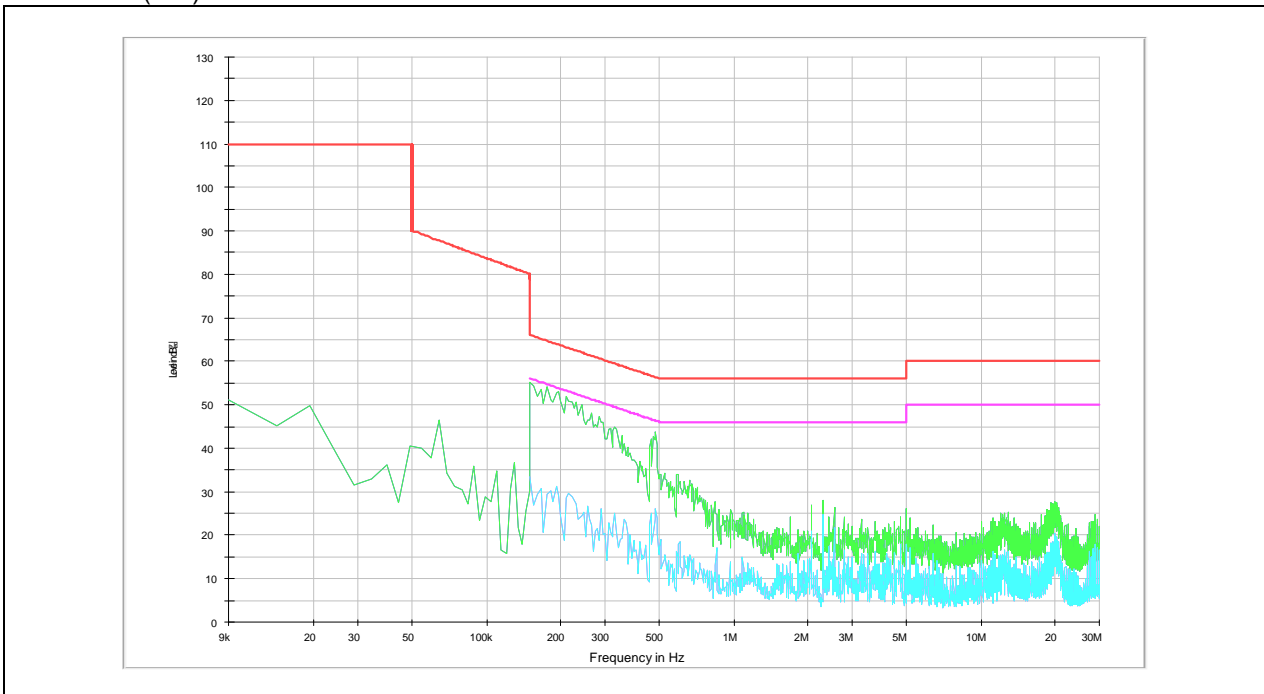

Ant. 1 (126.2 kHz ~ 129.2 kHz) & Ant. 6 (144.5 kHz ~ 147.5 kHz) & Ant. 7 (144.5 kHz ~ 147.5 kHz)

FREQ. (MHz)	LEVEL (dB μ V)		LINE	LIMIT (dB μ V)		MARGIN (dB)	
	Q-Peak	Average		Q-Peak	Average	Q-Peak	Average
0.15	52.20	35.20	N	66.00	56.00	13.80	20.80
0.18	50.80	31.20	N	64.49	54.49	13.69	23.29
0.46	42.00	30.20	N	56.69	46.69	14.69	16.49
5.05	28.60	19.20	N	60.00	50.00	31.40	30.80
12.54	32.90	25.60	N	60.00	50.00	27.10	24.40
19.89	25.40	17.00	N	60.00	50.00	34.60	33.00
0.16	51.50	36.60	H	65.46	55.46	13.96	18.86
0.18	49.50	30.80	H	64.49	54.49	14.99	23.69
0.46	37.90	26.60	H	56.69	46.69	18.79	20.09
3.26	23.60	18.20	H	56.00	46.00	32.40	27.80
5.19	23.90	18.50	H	60.00	50.00	36.10	31.50
12.51	30.10	23.60	H	60.00	50.00	29.90	26.40

Remark;

1. Line (H): Hot, Line (N): Neutral
2. Each charging mode with client device (1 %, 50 % and 99 % of battery) was tested.
As worst condition, charging mode with client device (1 %) is reported.
3. The limit for Class B device(s) from 150 kHz to 30 MHz are specified in section of the Title 47 CFR.
4. Traces shown in plot were made by using a peak detector and average detector.
5. Deviations to the Specifications: None.

- Test plots

Test mode: (Neutral)

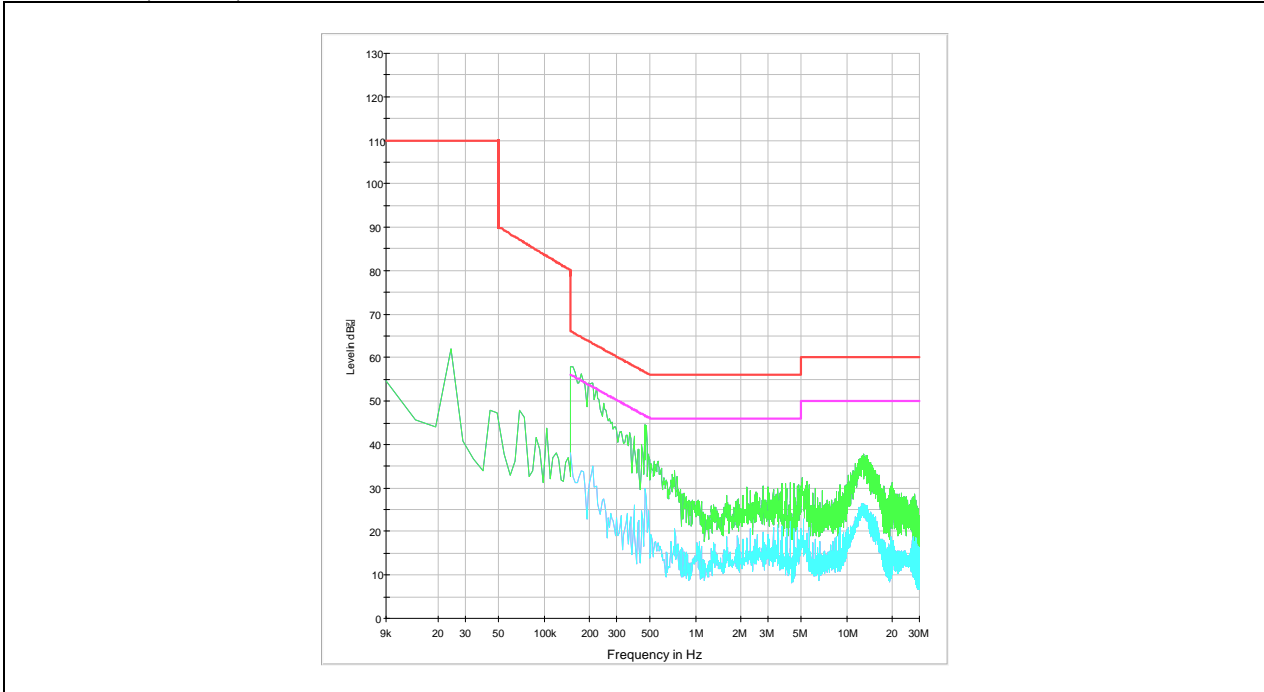

Test mode: (Hot)

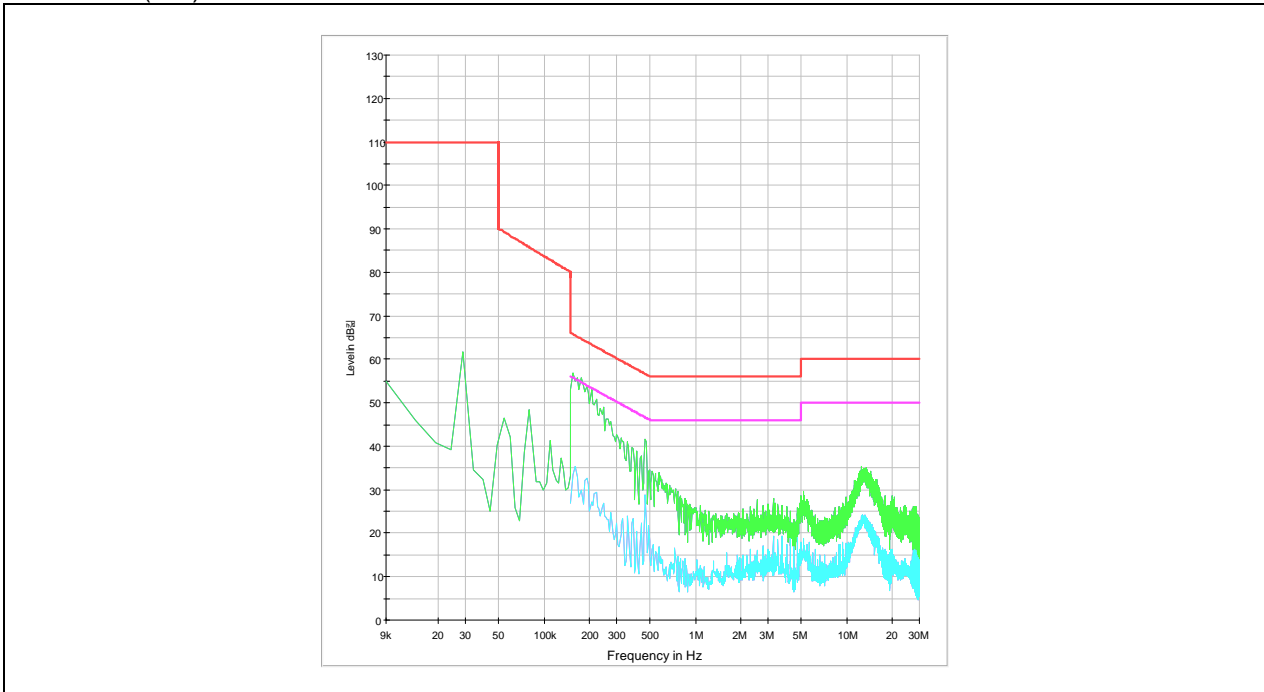

Test Condition: Ping mode with client device (Standby mode)

Ant. All (136.5 kHz ~ 139.5 kHz & 144.5 kHz ~ 147.5 kHz)

FREQ. (MHz)	LEVEL (dB μ V)		LINE	LIMIT (dB μ V)		MARGIN (dB)	
	Q-Peak	Average		Q-Peak	Average	Q-Peak	Average
0.16	44.10	24.90	N	65.46	55.46	21.36	30.56
0.17	43.30	24.60	N	64.96	54.96	21.66	30.36
0.47	36.90	26.70	N	56.51	46.51	19.61	19.81
2.48	20.60	17.40	N	56.00	46.00	35.40	28.60
4.18	22.20	15.70	N	56.00	46.00	33.80	30.30
19.84	28.00	22.50	N	60.00	50.00	32.00	27.50
0.16	44.00	24.90	H	65.46	55.46	21.46	30.56
0.22	39.70	19.40	H	62.82	52.82	23.12	33.42
0.48	31.00	22.70	H	56.34	46.34	25.34	23.64
4.18	18.70	13.80	H	56.00	46.00	37.30	32.20
12.54	18.00	14.00	H	60.00	50.00	42.00	36.00
19.23	22.90	15.40	H	60.00	50.00	37.10	34.60

Remark;

- Line (H): Hot, Line (N): Neutral
- Each charging mode with client device (1 %, 50 % and 99 % of battery) was tested.
As worst condition, charging mode with client device (1 %) is reported.
- The limit for Class B device(s) from 150 kHz to 30 MHz are specified in section of the Title 47 CFR.
- Traces shown in plot were made by using a peak detector and average detector.
- Deviations to the Specifications: None.

- Test plots

Test mode: (Neutral)

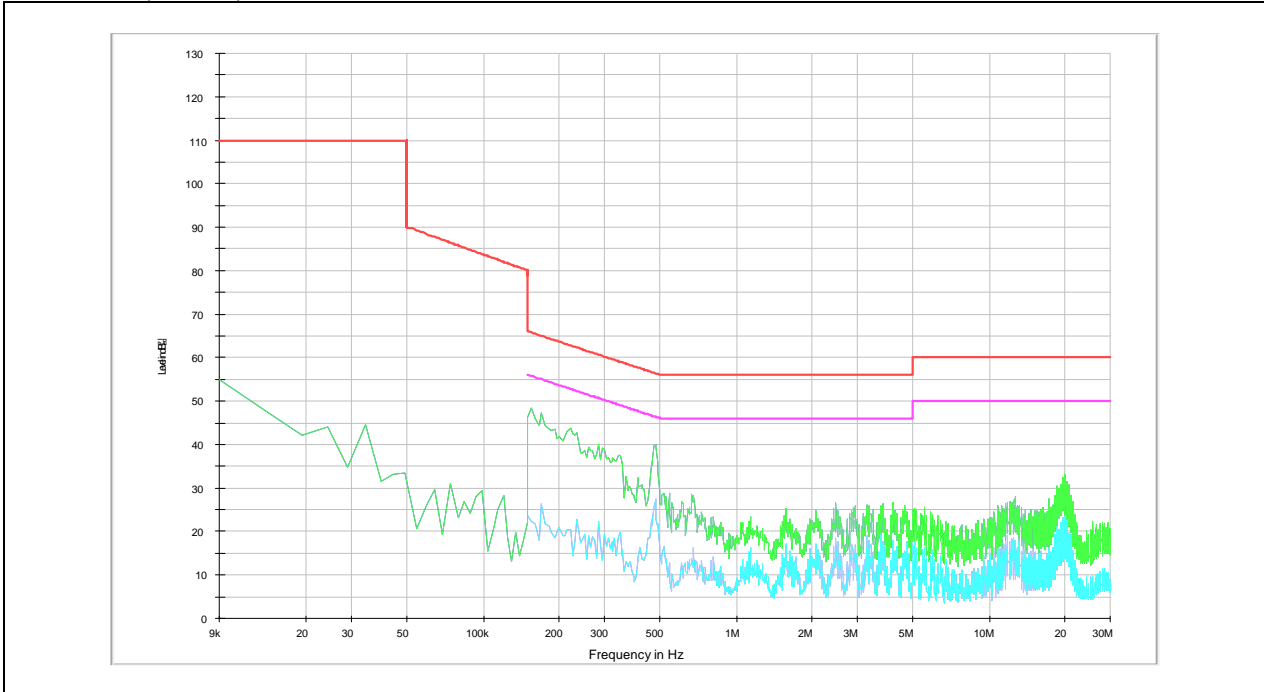

Test mode: (Hot)

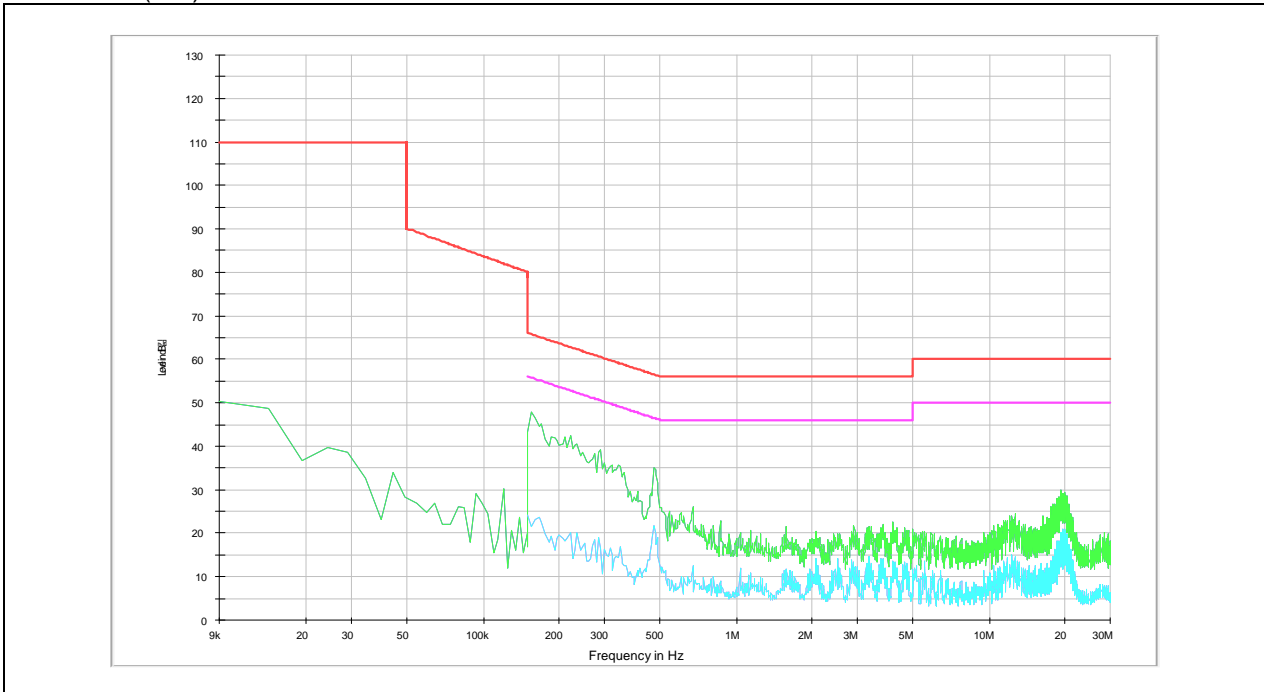

- End of the Test Report -