

TEST REPORT

of

FCC Part 15 Subpart C §15.209

FCC ID: A3LEPP3100

Equipment Under Test : WIRELESS CHARGER
Model Name : EP-P3100
Applicant : Samsung Electronics Co., Ltd.
Manufacturer : Samsung Electronics Co., Ltd.
Date of Receipt : 2018.06.04
Date of Test(s) : 2018.06.11 ~ 2018.06.29
Date of Issue : 2018.06.29

In the configuration tested, the EUT complied with the standards specified above.

Tested By:



Nancy Park

Date:

2018.06.29

**Technical
Manager:**



Jungmin Yang

Date:

2018.06.29

The results shown in this test report refer only to the sample(s) tested unless otherwise stated. This test report cannot be reproduced, except in full, without prior written permission of the Company. This test report does not assure KOLAS accreditation.

Table of contents

1. General information -----	3
2. Field Strength of Fundamental and Spurious Emission -----	7
3. 20 dB Bandwidth -----	22
4. AC Conducted Power Line Emissions -----	26

The results shown in this test report refer only to the sample(s) tested unless otherwise stated. This test report cannot be reproduced, except in full, without prior written permission of the Company. This test report does not assure KOLAS accreditation.

1. General information

1.1. Testing laboratory

SGS Korea Co., Ltd. (Gunpo Laboratory)

-Wireless Div. 2FL, 10-2, LS-ro 182beon-gil, Gunpo-si, Gyeonggi-do, Korea, 15807

-Designation number: KR0150

All SGS services are rendered in accordance with the applicable SGS conditions of service available on request and accessible at <http://www.sgs.com/en/Terms-and-Conditions.aspx>.

Phone No. : +82 31 688 0901

Fax No. : +82 31 688 0921

1.2. Details of applicant

Applicant : Samsung Electronics Co., Ltd.

Address : 19 Chapin Rd., Building D, Pine Brook, New Jersey, United States, 07058

Contact Person : Youn, Chan-Ho

Phone No. : +1 973 808 6362

1.3. Details of manufacturer

Company : Samsung Electronics Co., Ltd.

Address : Yen Phong 1 Industrial park, Yen Phong District Ninh Province VIETNAM

1.4. Description of EUT

Kind of Product	WIRELESS CHARGER	
Model Name	EP-P3100	
Power Supply	DC 5.0 V, DC 9.0 V	
Frequency Range	DC 5 V Wireless Charger	DC 9 V Wireless Charger
	Ant. 1: 110 kHz ~ 148 kHz Ant. 2: 110 kHz ~ 148 kHz	Ant. 1: 125 kHz ~ 148 kHz
Antenna Type	Inductive loop coil antenna	
H/W Version	EP-P3100_0.2	
S/W Version	-	

1.5. Declaration by the manufacturer

- The EUT has 2 inductive loop coil antennas and can be operating individually for mobile and gear. (For the details, please refer to Test setup photo)

The results shown in this test report refer only to the sample(s) tested unless otherwise stated. This test report cannot be reproduced, except in full, without prior written permission of the Company. This test report does not assure KOLAS accreditation.

SGS Korea Co., Ltd. (Gunpo Laboratory) 4, LS-ro 182beon-gil, Gunpo-si, Gyeonggi-do, Korea, 15807 <http://www.sgsgroup.kr>

1.6. Test Equipment List

Equipment	Manufacturer	Model	S/N	Cal. Date	Cal. Interval	Cal. Due
Spectrum Analyzer	R&S	FSV30	100768	Mar. 12, 2018	Annual	Mar. 12, 2019
Signal Generator	R&S	SMBV100A	255834	Jun. 15, 2018	Annual	Jun. 15, 2019
Test Receiver	R&S	ESU26	100109	Feb. 07, 2018	Annual	Feb. 07, 2019
Loop Antenna	Schwarzbeck Mess-Elektronik	FMZB 1519	1519-039	Aug. 23, 2017	Biennial	Aug. 23, 2019
Turn Table	Innco systems GmbH	DS 1200 S	N/A	N.C.R.	N/A	N.C.R.
Controller	Innco systems GmbH	CONTROLLER CO3000-4P	CO3000/963/3 8330516/L	N.C.R.	N/A	N.C.R.
Anechoic Chamber	SY Corporation	L x W x H (9.6 m x 6.4 m x 6.6 m)	N/A	N.C.R.	N/A	N.C.R.
Coaxial Cable	SUCOFLEX	104 (3 m)	MY3258414	Jan. 12, 2018	Semi-annual	Jul. 12, 2018
Coaxial Cable	SUCOFLEX	104 (10 m)	MY3145814	Jan. 12, 2018	Semi-annual	Jul. 12, 2018
Test Receiver	R&S	ESCI 7	100911	Feb. 20, 2018	Annual	Feb. 20, 2019
Two-Line V-Network	R&S	ENV216	100190	May 14, 2018	Annual	May 14, 2019
Shield Room	SY Corporation	L x W x H (6.5 m x 3.5 m x 3.5 m)	N/A	N.C.R.	N/A	N.C.R.

► Support equipment

Description	Manufacturer	Model	FCC ID
Samsung Mobile Phone	Samsung Electronics Co., Ltd.	SM-G960U	A3LSMG960U
Smart Wearable Device	Samsung Electronics Co., Ltd.	SM-R775U	A3LSMR775U

1.7. Sample calculation

Where relevant, the following sample calculation is provided:

Field strength level (dB μ V/m) = Measured level (dB μ V) + Antenna factor (dB) + Cable loss (dB)

The results shown in this test report refer only to the sample(s) tested unless otherwise stated. This test report cannot be reproduced, except in full, without prior written permission of the Company. This test report does not assure KOLAS accreditation.

1.8. Worst case of test configurations

In order to check all kinds of possible configurations, EUT was evaluated with appropriate client and under each charging condition as below table.

Charging mode with client device	Mode		Description
Model: SM-G960U IC Certification: 649E-SMG960U	Operating DC 5 V	Operating DC 9 V	1 % of battery 50 % of battery 99 % of battery
Model: SM-R775U IC Certification: 649E-SMR775U	(Ant. 1) (Ant. 2)	(Ant. 1)	

Note;

EUT was investigated with client device under normal charging condition as above then worst value was only reported.

1.9. Summary of Test Results

The EUT has been tested according to the following specifications:

APPLIED STANDARD: FCC Part 15 Subpart C §15.209		
Section	Test Item	Result
15.209	Radiated emission, Spurious Emission and Field Strength of Fundamental	Complied
2.1049	20 dB Bandwidth	Complied
15.207	AC Power Line Conducted Emission	Complied

Note;

Due to the frequency range of the device (110 kHz ~ 148 kHz) is less than 1 MHz, so we didn't test Lowest and Highest frequency according to 15.31 requirement.

The results shown in this test report refer only to the sample(s) tested unless otherwise stated. This test report cannot be reproduced, except in full, without prior written permission of the Company. This test report does not assure KOLAS accreditation.

1.10. Measurement Uncertainty

Where relevant, the following measurement uncertainty levels have been estimated for tests performed on the apparatus:

Parameter	Uncertainty (dB)
Conducted Disturbance	± 3.30
Radiated Disturbance, 9 kHz to 30 MHz	± 3.59
Radiated Disturbance, below 1 GHz	± 5.88

Uncertainty figures are valid to a confidence level of 95 %.

1.11. Test Report Revision

Revision	Report number	Date of Issue	Description
0	F690501/RF-RTL012819	2018.06.29	Initial

The results shown in this test report refer only to the sample(s) tested unless otherwise stated. This test report cannot be reproduced, except in full, without prior written permission of the Company. This test report does not assure KOLAS accreditation.

2. Field Strength of Fundamental and Spurious Emission

2.1. Test Setup

The diagram below shows the test setup that is utilized to make the measurements for emission from 9 kHz to 30 MHz.

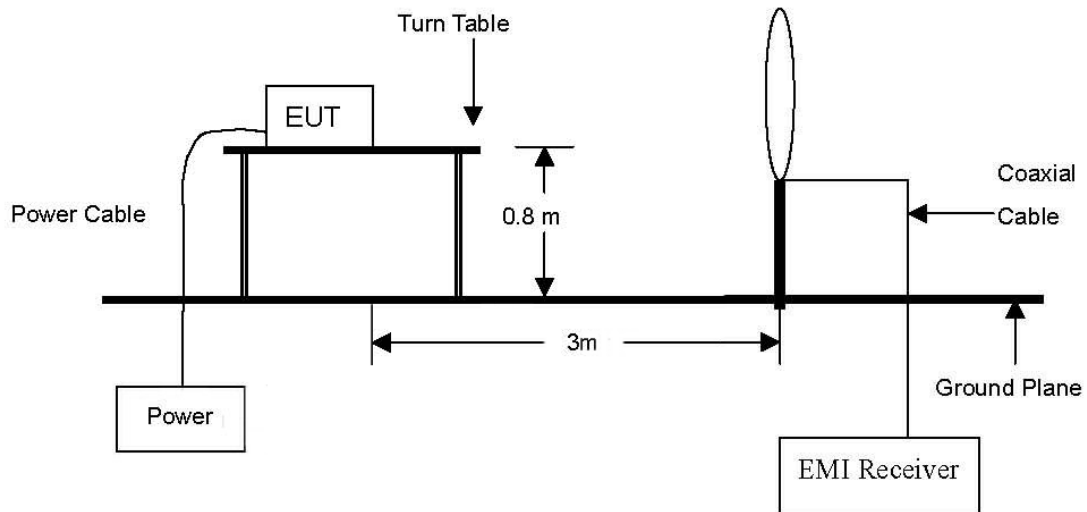

The results shown in this test report refer only to the sample(s) tested unless otherwise stated. This test report cannot be reproduced, except in full, without prior written permission of the Company. This test report does not assure KOLAS accreditation.

2.2. Limit

2.2.1. Radiated emission limits, general requirements

According to §15.209 (a), except as provided elsewhere in this subpart, the emissions from an intentional radiator shall not exceed the field strength levels specified in the following table:

Frequency (MHz)	Field Strength (microvolts/meter)	Measurement Distance (meter)
0.009-0.490	2 400/F(kHz)	300
0.490-1.705	24 000/F(kHz)	30
1.705-30.0	30	30
30-88	100**	3
88-216	150**	3
216-960	200**	3
Above 960	500	3

** Except as provided in paragraph (g), fundamental emissions from intentional radiators operating under this section shall not be located in the frequency bands 54-72 MHz, 76-88 MHz, 174-216 MHz or 470-806 MHz. however, operation within these frequency bands is permitted under other sections of this part, e.g., §§15.231 and 15.241.

2.3. Test Procedures

Radiated emissions from the EUT were measured according to the dictates of ANSI C63.10:2013.

2.3.1. Test Procedures for emission from 9 kHz to 30 MHz

- The EUT was placed on the top of a rotating table 0.8 meters above the ground at a 3 meter anechoic chamber test site. The table was rotated 360 degrees to determine the position of the highest radiation.
- Then antenna is a loop antenna is fixed at one meter above the ground to determine the maximum value of the field strength. Both parallel and perpendicular of the antenna are set to make the measurement.
- For each suspected emission, the EUT was arranged to its worst case and then the table was turned from 0 degrees to 360 degrees to find the maximum reading.
- The test-receiver system was set to Quasi Peak and Average Detect Function and Specified Bandwidth with Maximum Hold Mode.

Note;

Although these tests were performed other than open field test site, adequate comparison measurements were confirmed against 30 meter open field test site. Therefore sufficient tests were made to demonstrate that the alternative site produces results that correlate with the ones of tests made in an open field based on KDB 414788 D01 Radiated Test Site v01.

The results shown in this test report refer only to the sample(s) tested unless otherwise stated. This test report cannot be reproduced, except in full, without prior written permission of the Company. This test report does not assure KOLAS accreditation.

2.4. Field Strength of Fundamental Test Result

Ambient temperature : (23 ± 1) °C
 Relative humidity : 47 % R.H.

The following table shows the highest levels of radiated emissions on both polarizations of horizontal and vertical. The field strength of spurious emission was measured in one orthogonal EUT position (X-axis).

Test Condition: DC 5 V Operating mode with client device (1 % battery status of client device)

Radiated Emissions			Ant.	Correction Factors		Total		Limit	
Frequency (MHz)	Reading (dB μ V)	Detect Mode	Pol.	Ant. (dB/m)	Cable (dB)	Actual (dB μ V/m) at 3 m	Actual (dB μ V/m) at 300 m	Limit (dB μ V/m) at 300 m	Margin (dB)
Ant. 1 (110 kHz ~ 148 kHz)									
0.125	62.20	Average	H	19.69	0.06	81.95	1.95	25.67	23.72
Ant. 2 (110 kHz ~ 148 kHz)									
0.125	54.70	Average	H	19.69	0.06	74.45	-5.55	25.67	31.22

Test Condition: DC 9 V Operating mode with client device (1 % battery status of client device)

Radiated Emissions			Ant.	Correction Factors		Total		Limit	
Frequency (MHz)	Reading (dB μ V)	Detect Mode	Pol.	Ant. (dB/m)	Cable (dB)	Actual (dB μ V/m) at 3 m	Actual (dB μ V/m) at 300 m	Limit (dB μ V/m) at 300 m	Margin (dB)
Ant. 1 (125 kHz ~ 148 kHz)									
0.136	65.20	Average	H	19.68	0.07	84.95	4.95	24.93	19.98

Remark:

1. According to §15.31 (f)(2), 300 m Result (dB μ V/m) = 3 m Result (dB μ V/m) - 40log(300/3) (dB μ V/m).
2. According to §15.209 (d), the measurements were tested by using Quasi peak detector except for the frequency bands 9-90 kHz, 110-490 kHz and above 1 GHz in these three bands on measurements employing an average detector.
3. The limit above was calculated based on table of §15.209 (a).

The results shown in this test report refer only to the sample(s) tested unless otherwise stated. This test report cannot be reproduced, except in full, without prior written permission of the Company. This test report does not assure KOLAS accreditation.

Test plots

Test Condition: DC 5 V Operating mode with client device (1 % battery status of client device)

Ant. 1

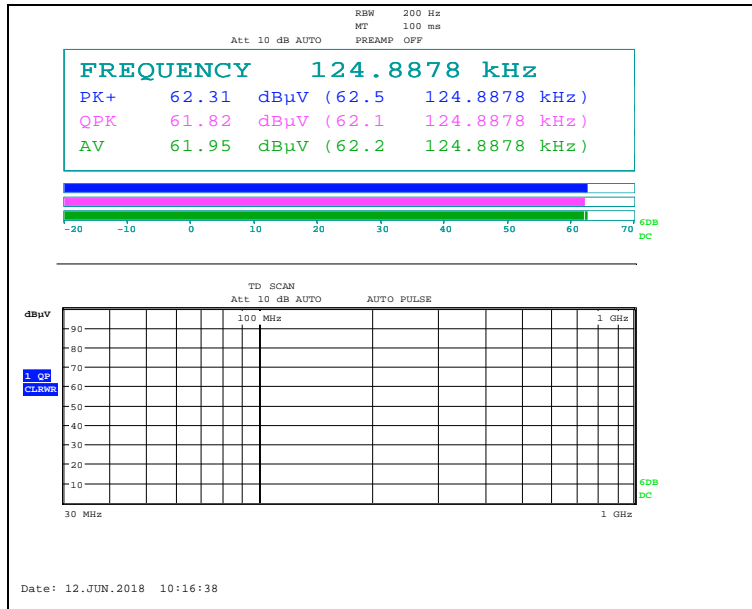

Ant. 2

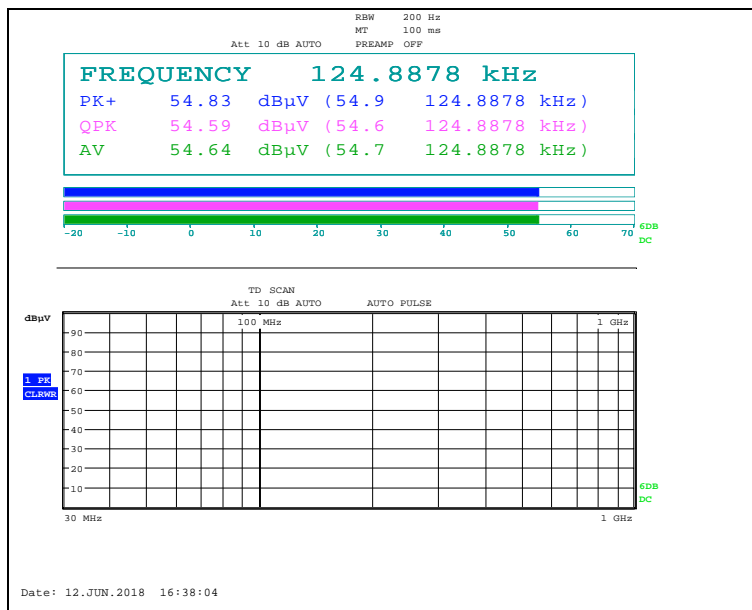

The results shown in this test report refer only to the sample(s) tested unless otherwise stated. This test report cannot be reproduced, except in full, without prior written permission of the Company. This test report does not assure KOLAS accreditation.

Test Condition: DC 9 V Operating mode with client device (1 % battery status of client device)

Ant. 1

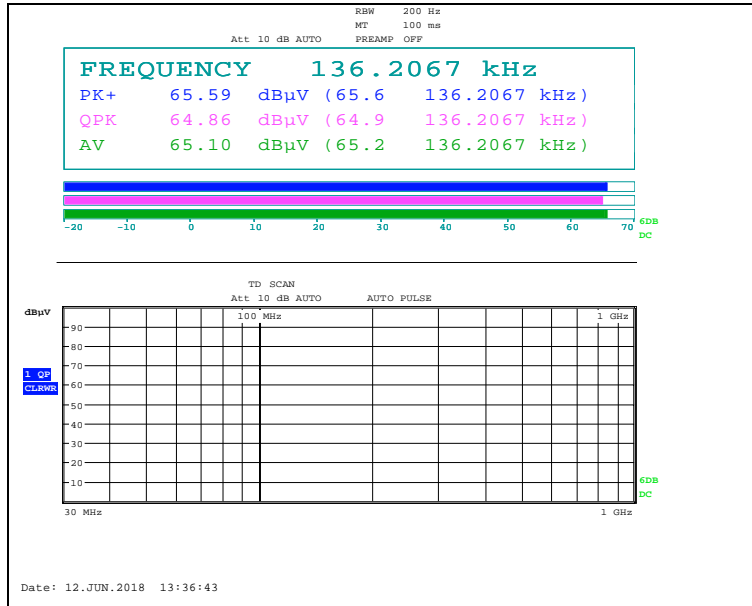

The results shown in this test report refer only to the sample(s) tested unless otherwise stated. This test report cannot be reproduced, except in full, without prior written permission of the Company. This test report does not assure KOLAS accreditation.

2.5. Spurious Emission Test Result

Ambient temperature : (23 ± 1) °C
 Relative humidity : 47 % R.H.

The following table shows the highest levels of radiated emissions on both polarizations of horizontal and vertical.

Test Condition: DC 5 V Operating mode with client device (1 % battery status of client device)

Ant. 1

Radiated Emissions			Ant.	Correction Factors		Total		Limit	
Frequency (MHz)	Reading (dB μ V)	Detect Mode	Pol.	Ant. (dB/m)	Cable (dB)	Actual (dB μ V/m) at 3 m	Actual (dB μ V/m) at 300 m or 30 m	Limit (dB μ V/m) at 300 m or 30 m	Margin (dB)
0.019	32.80	Average	H	19.97	0.03	52.80	-27.20	42.03	69.23
0.046	22.40	Average	H	19.78	0.03	42.21	-37.79	34.35	72.14
0.375	33.90	Average	H	19.60	0.28	53.78	-26.22	16.12	42.34
0.626	24.10	Quasi Peak	H	19.63	0.50	44.23	4.23	31.67	27.44
Above 1.000	Not detected	-	-	-	-	-	-	-	-

Ant. 2

Radiated Emissions			Ant.	Correction Factors		Total		Limit	
Frequency (MHz)	Reading (dB μ V)	Detect Mode	Pol.	Ant. (dB/m)	Cable (dB)	Actual (dB μ V/m) at 3 m	Actual (dB μ V/m) at 300 m or 30 m	Limit (dB μ V/m) at 300 m or 30 m	Margin (dB)
0.018	38.80	Average	H	19.98	0.03	58.81	-21.19	42.50	63.69
0.046	30.80	Average	H	19.78	0.03	50.61	-29.39	34.35	63.74
0.067	33.90	Average	H	19.75	0.04	53.69	-26.31	31.08	57.39
0.375	32.10	Average	H	19.60	0.28	51.98	-28.02	16.12	44.14
0.625	23.40	Quasi Peak	H	19.63	0.50	43.53	3.53	31.69	28.16
Above 1.000	Not detected	-	-	-	-	-	-	-	-

The results shown in this test report refer only to the sample(s) tested unless otherwise stated. This test report cannot be reproduced, except in full, without prior written permission of the Company. This test report does not assure KOLAS accreditation.

Test Condition: DC 9 V Operating mode with client device (1 % battery status of client device)
-Ant. 1

Radiated Emissions			Ant.	Correction Factors		Total		Limit	
Frequency (MHz)	Reading (dB μ V)	Detect Mode	Pol.	Ant. (dB/m)	Cable (dB)	Actual (dB μ V/m) at 3 m	Actual (dB μ V/m) at 300 m or 30 m	Limit (dB μ V/m) at 300 m or 30 m	Margin (dB)
0.019	33.60	Average	H	19.97	0.03	53.60	-26.40	42.03	68.43
0.048	23.30	Average	H	19.77	0.03	43.10	-36.90	33.98	70.88
0.067	27.40	Average	H	19.75	0.04	47.19	-32.81	31.08	63.89
0.409	42.90	Average	H	19.60	0.31	62.81	-17.19	15.37	32.56
0.681	34.90	Quasi Peak	H	19.64	0.55	55.09	15.09	30.94	15.85
Above 1.000	Not detected	-	-	-	-	-	-	-	-

Remark:

- According to §15.31 (f)(2)
 - 300 m Result (dB μ V/m) = 3 m Result (dB μ V/m) - 40log(300/3) (dB μ V/m)
 - 30 m Result (dB μ V/m) = 3 m Result (dB μ V/m) - 40log(30/3) (dB μ V/m)
- According to field strength table of general requirement in §15.209 (a), field strength limits below 1.705 MHz were calculated as below.
 - 9 kHz to 490 kHz: 20log(2 400 / F (kHz)) at 300 m (dB μ V/m)
 - 490 kHz to 1.705 MHz: 20log (24 000 / F (kHz)) at 30 m (dB μ V/m)
- According to §15.209 (d), the measurements were tested by using Quasi peak detector except for the frequency bands 9-90 kHz, 110-490 kHz and above 1 GHz in these three bands on measurements employing an average detector.

The results shown in this test report refer only to the sample(s) tested unless otherwise stated. This test report cannot be reproduced, except in full, without prior written permission of the Company. This test report does not assure KOLAS accreditation.

Test Condition: DC 5 V Operating mode with client device (1 % battery status of client device)

Test plots

- Ant. 1

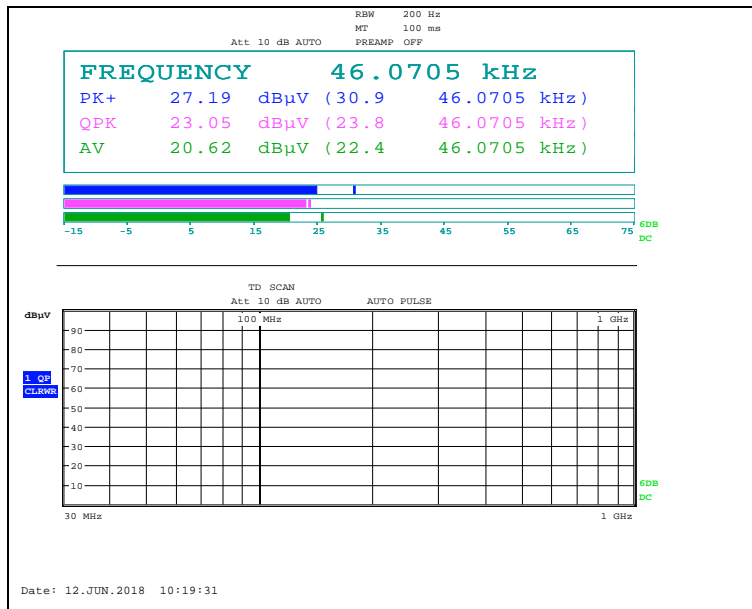
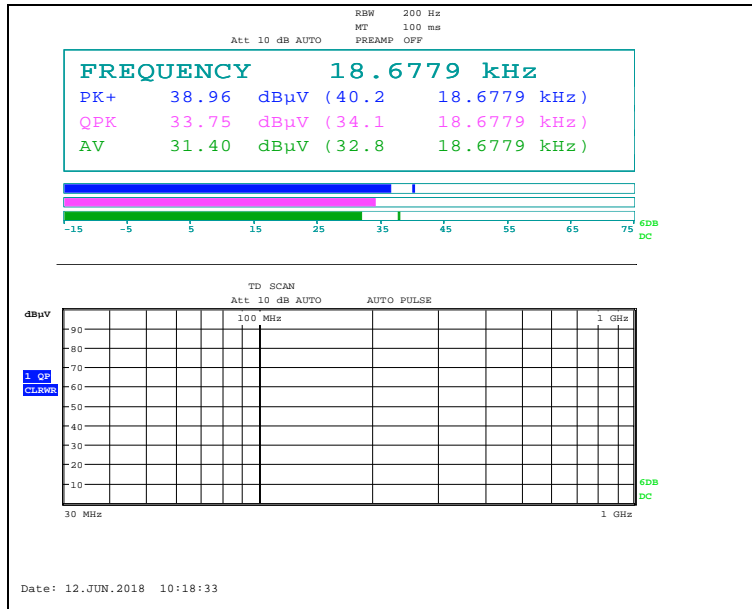

The results shown in this test report refer only to the sample(s) tested unless otherwise stated. This test report cannot be reproduced, except in full, without prior written permission of the Company. This test report does not assure KOLAS accreditation.

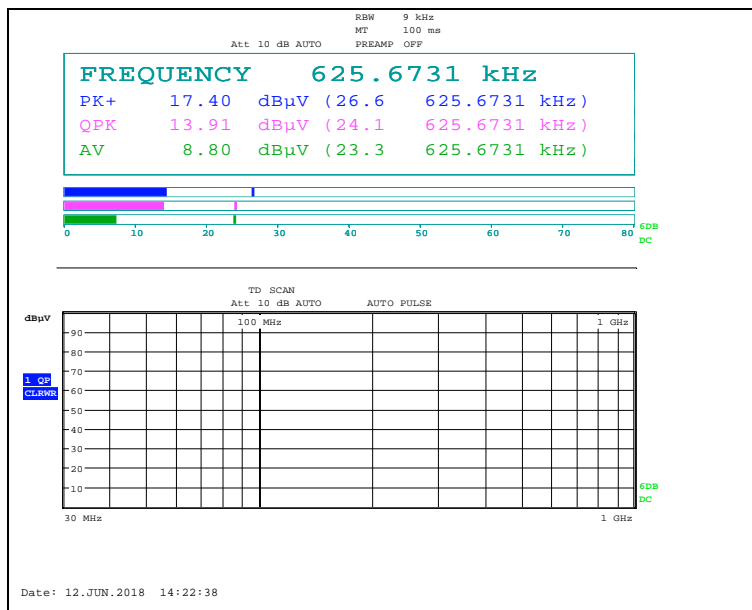
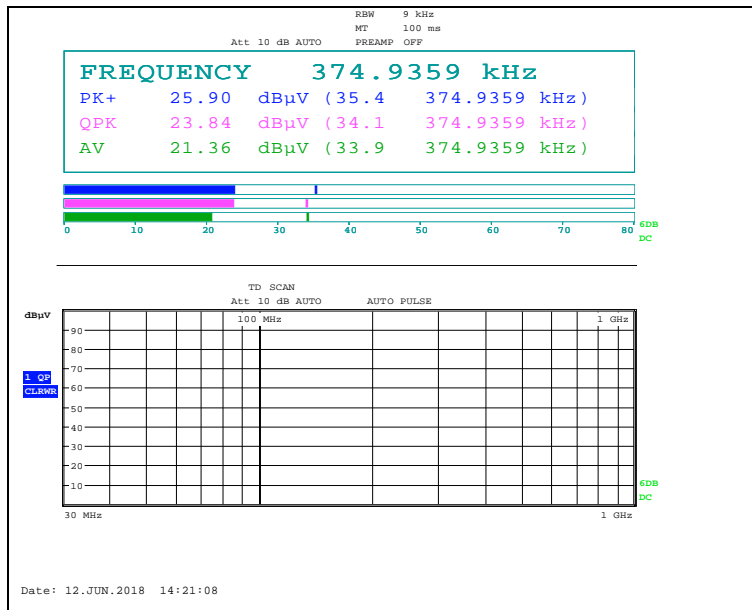

The results shown in this test report refer only to the sample(s) tested unless otherwise stated. This test report cannot be reproduced, except in full, without prior written permission of the Company. This test report does not assure KOLAS accreditation.

- Ant. 2

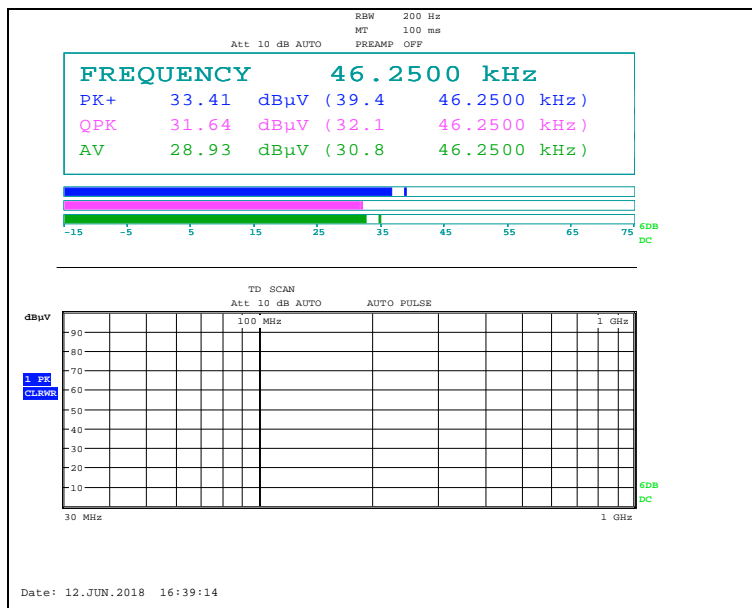
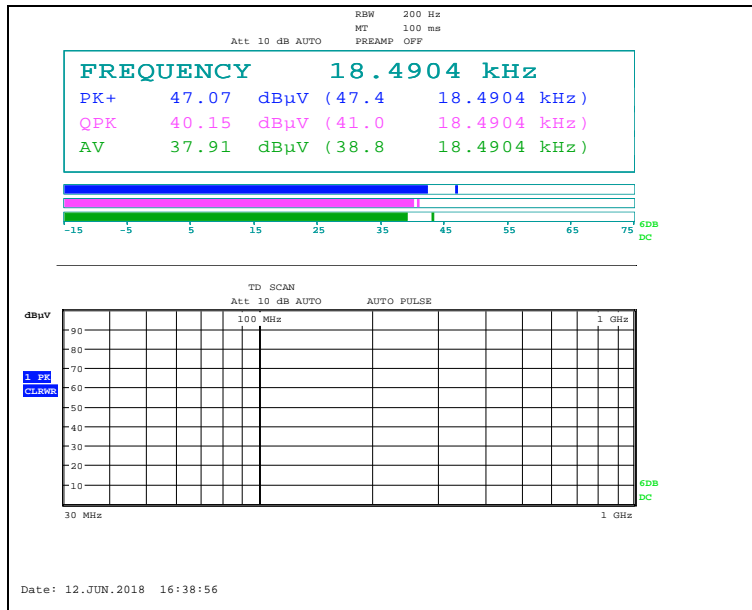

The results shown in this test report refer only to the sample(s) tested unless otherwise stated. This test report cannot be reproduced, except in full, without prior written permission of the Company. This test report does not assure KOLAS accreditation.

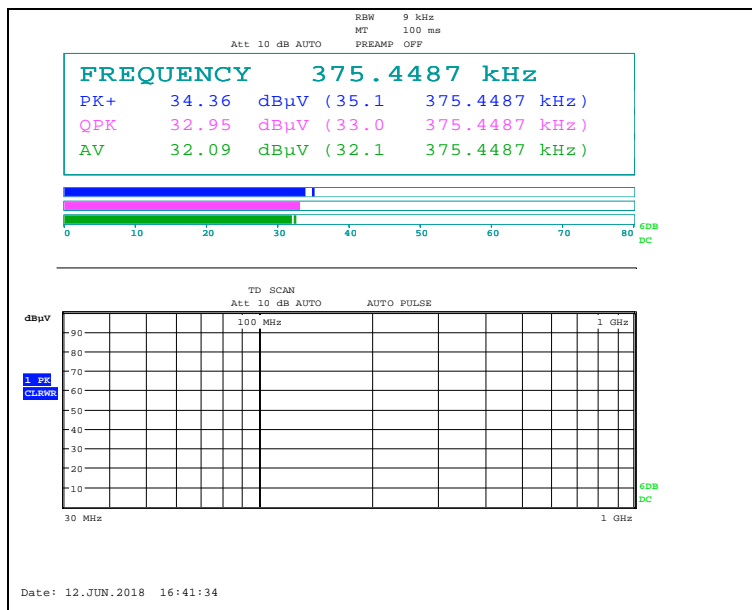
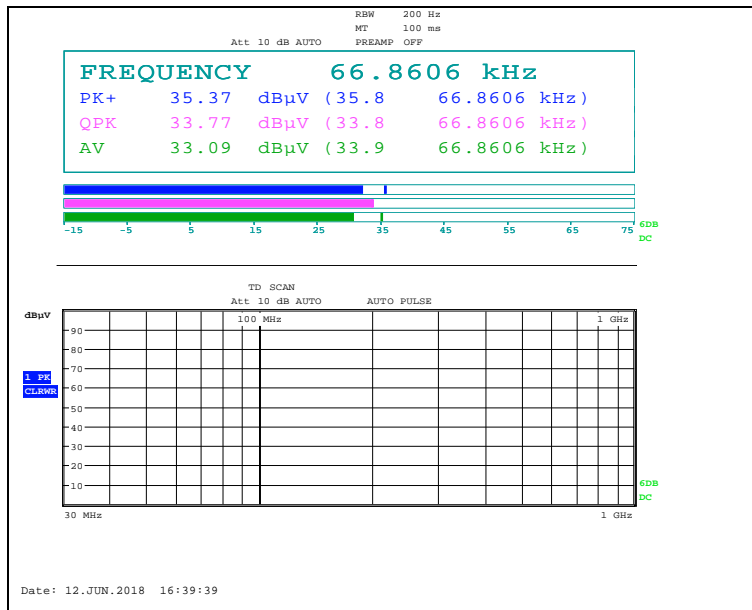

The results shown in this test report refer only to the sample(s) tested unless otherwise stated. This test report cannot be reproduced, except in full, without prior written permission of the Company. This test report does not assure KOLAS accreditation.

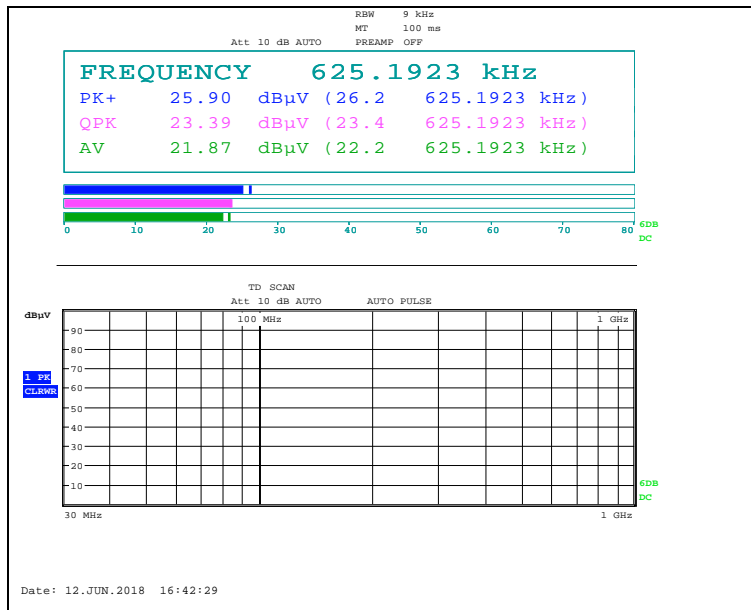

The results shown in this test report refer only to the sample(s) tested unless otherwise stated. This test report cannot be reproduced, except in full, without prior written permission of the Company. This test report does not assure KOLAS accreditation.

Test Condition: DC 9 V Operating mode with client device (1 % battery status of client device)

Test plots

- Ant. 1

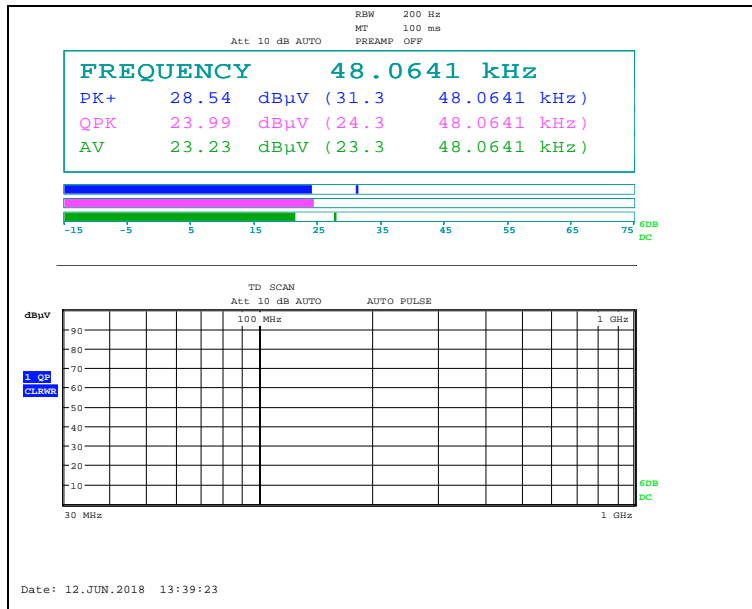
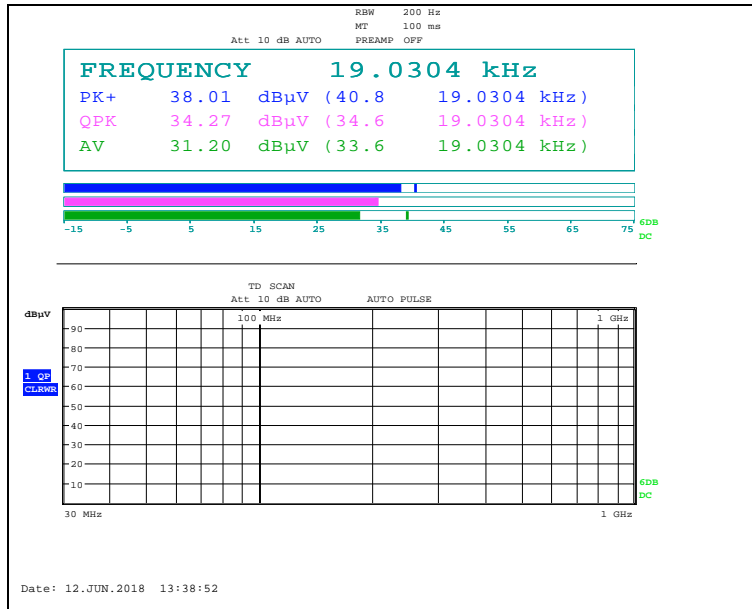

The results shown in this test report refer only to the sample(s) tested unless otherwise stated. This test report cannot be reproduced, except in full, without prior written permission of the Company. This test report does not assure KOLAS accreditation.

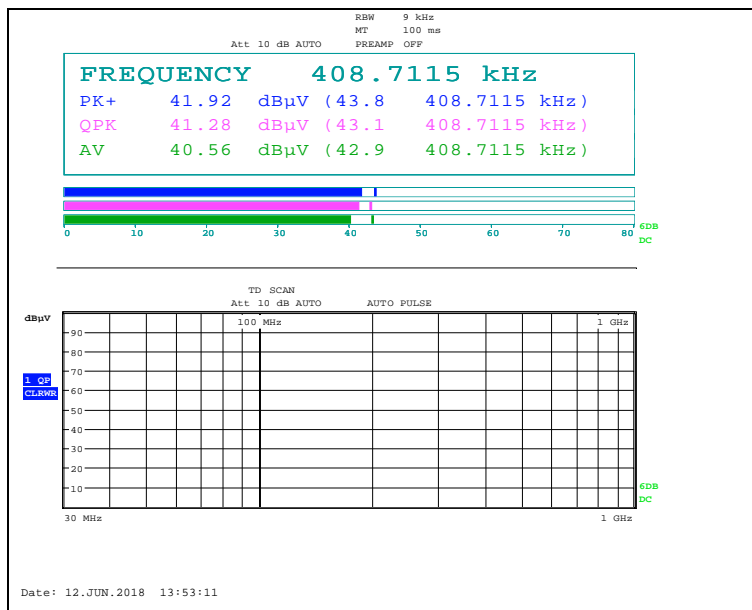
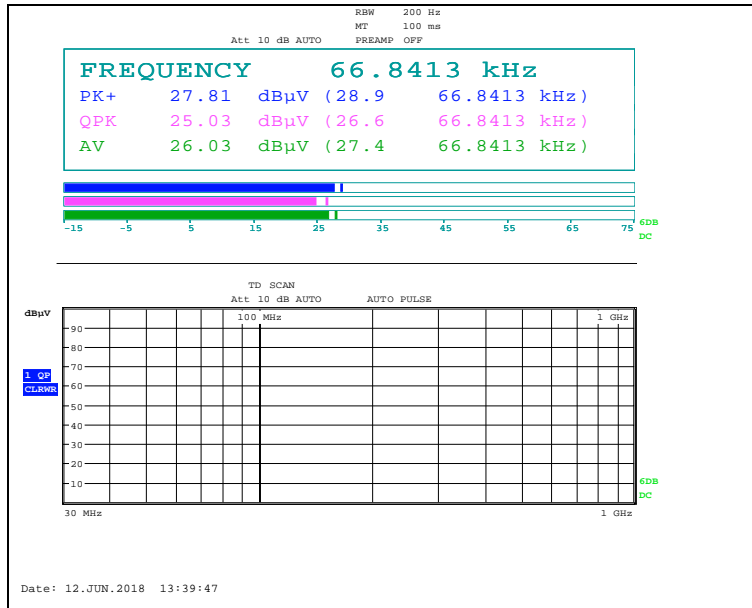

The results shown in this test report refer only to the sample(s) tested unless otherwise stated. This test report cannot be reproduced, except in full, without prior written permission of the Company. This test report does not assure KOLAS accreditation.

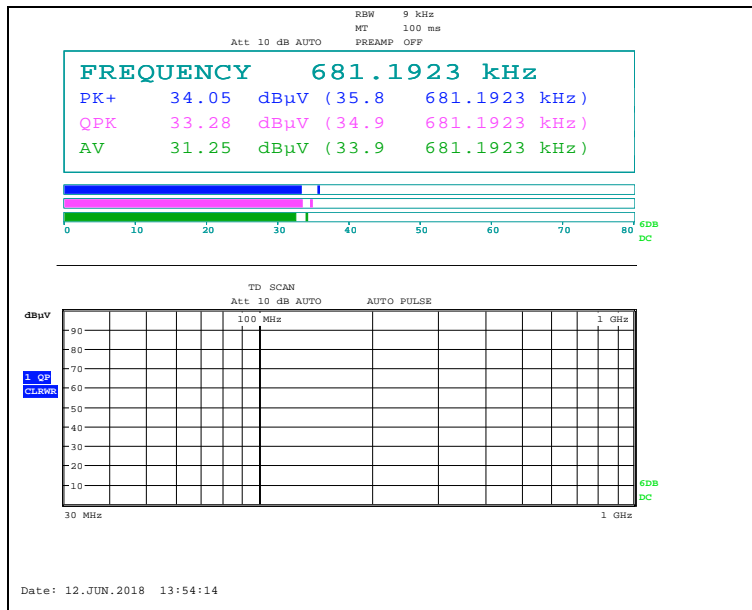

The results shown in this test report refer only to the sample(s) tested unless otherwise stated. This test report cannot be reproduced, except in full, without prior written permission of the Company. This test report does not assure KOLAS accreditation.

3. 20 dB Bandwidth

3.1. Test Setup

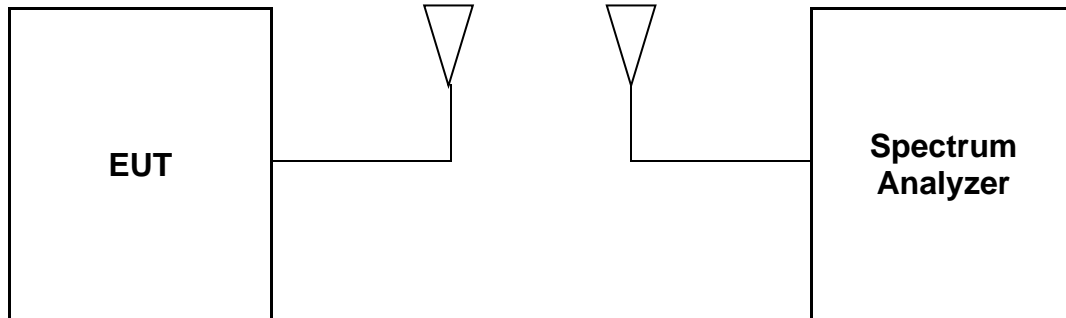

3.2. Limit

None; for reporting purposed only

3.3. Test Procedure

- a. Span = set to capture all products of the modulation process, including the emission skirts.
RBW = 200 Hz, VBW = 200 Hz, Sweep = auto, Detector = peak, Trace = max hold.
- b. The marker-to-peak function to set the mark to the peak of the emission. Use the marker-delta function to measure 20 dB down one side of the emission. Reset the function, and move the marker to the other side of the emission, until it is (as close as possible to) even with the reference marker level. The marker-delta reading at this point is 20 dB bandwidth of the emission.

The results shown in this test report refer only to the sample(s) tested unless otherwise stated. This test report cannot be reproduced, except in full, without prior written permission of the Company. This test report does not assure KOLAS accreditation.

3.4. Test Result

Ambient temperature : (23 ± 1) °C
 Relative humidity : 47 % R.H.

Test condition		EUT status	20 dB Bandwidth (kHz)	Limit
Operating DC 5 V	Ant. 1	With client device (1 % battery status of client device)	0.579	Reporting proposed only
	Ant. 2		1.505	
Operating DC 9 V	Ant. 1		0.557	

The results shown in this test report refer only to the sample(s) tested unless otherwise stated. This test report cannot be reproduced, except in full, without prior written permission of the Company. This test report does not assure KOLAS accreditation.

Operating DC 5 V

Ant. 1

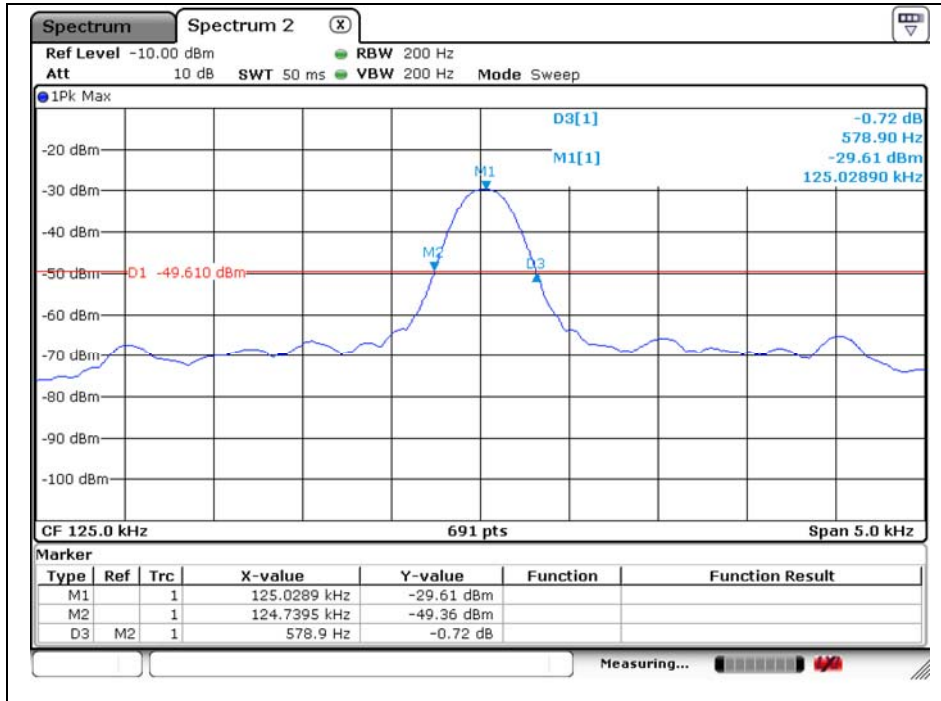

Ant. 2

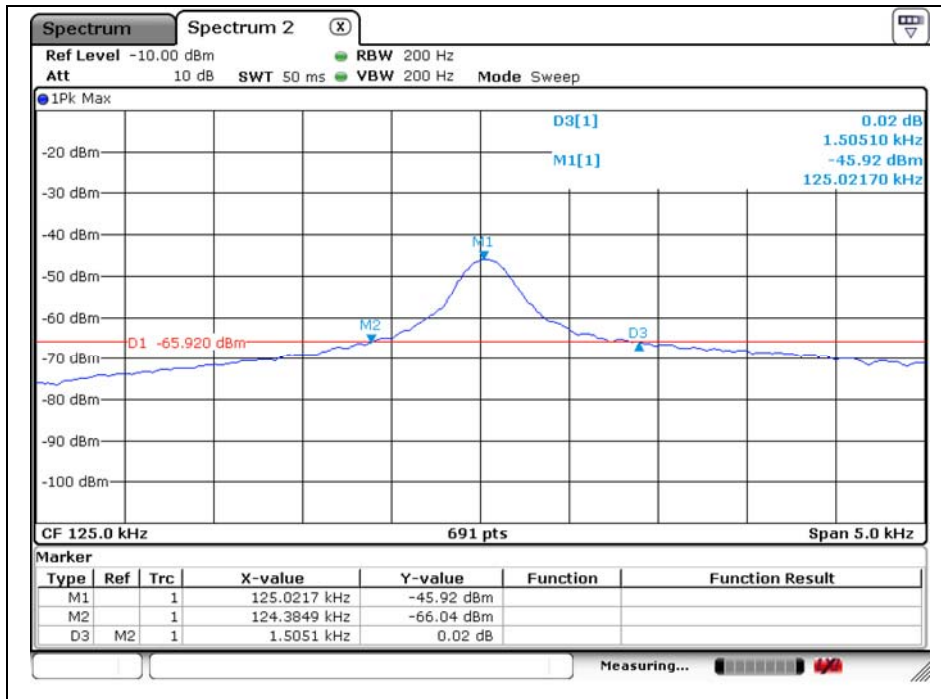

The results shown in this test report refer only to the sample(s) tested unless otherwise stated. This test report cannot be reproduced, except in full, without prior written permission of the Company. This test report does not assure KOLAS accreditation.

Operating DC 9 V

Ant. 1

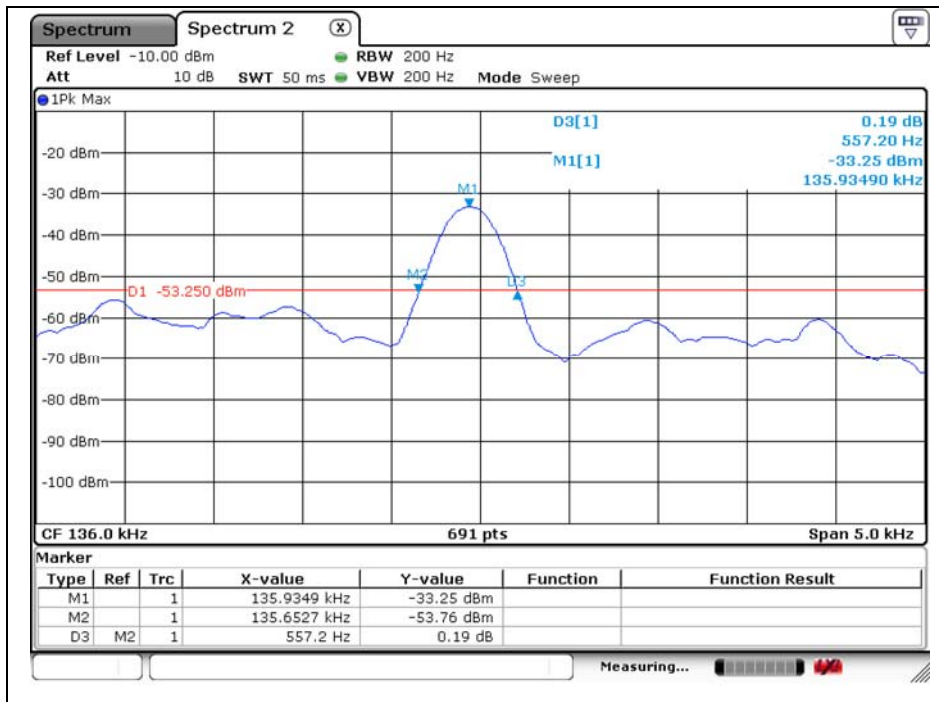

The results shown in this test report refer only to the sample(s) tested unless otherwise stated. This test report cannot be reproduced, except in full, without prior written permission of the Company. This test report does not assure KOLAS accreditation.

4. Transmitter AC Power Line Conducted Emission

4.1. Test Setup

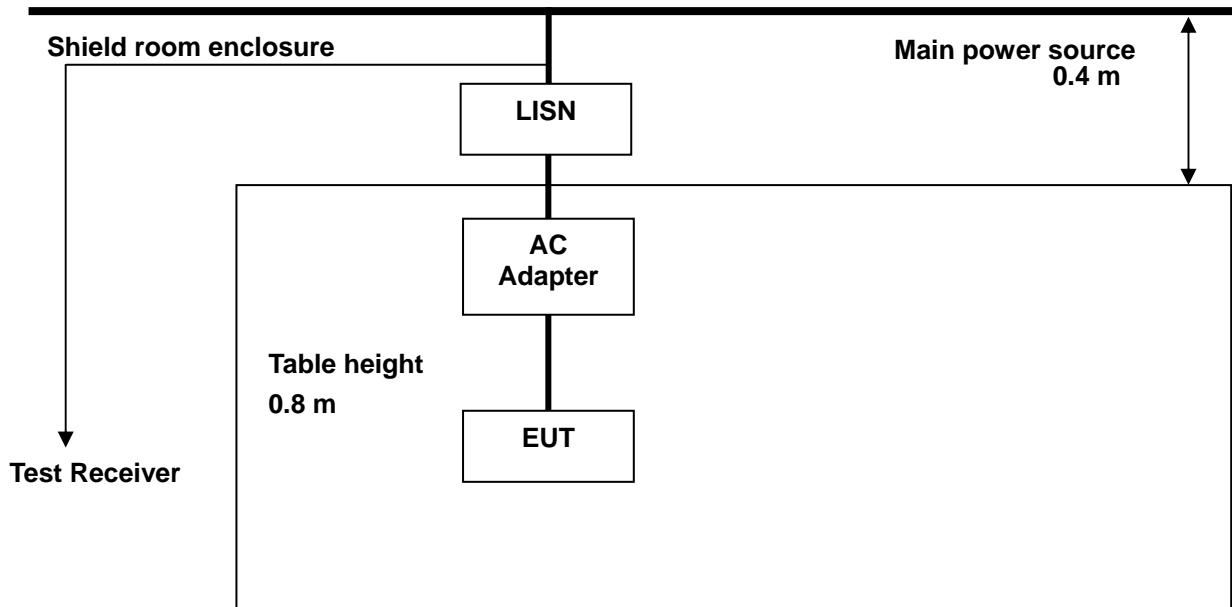

4.2. Limit

According to §15.207(a), for an intentional radiator that is designed to be connected to the public utility (AC) power line, the radio frequency voltage that is conducted back onto the AC power line on any frequency or frequencies, within the band 150 kHz to 30 MHz, shall not exceed the limits in the following table, as measured using a 50 μ H / 50 ohms line impedance stabilization network (LISN).

Compliance with the provision of this paragraph shall be based on the measurement of the radio frequency voltage between each power line and ground at the power terminal. The lower limit applies at the boundary between the frequency ranges.

Frequency of emission (MHz)	Conducted limit (dB μ V)	
	Quasi-peak	Average
0.15-0.5	66 to 56*	56 to 46*
0.5-5	56	46
5-30	60	50

* Decreases with the logarithm of the frequency.

The results shown in this test report refer only to the sample(s) tested unless otherwise stated. This test report cannot be reproduced, except in full, without prior written permission of the Company. This test report does not assure KOLAS accreditation.

4.3. Test Procedures

AC conducted emissions from the EUT were measured according to the dictates of ANSI C63.10:2013

1. The test procedure is performed in a 6.5 m × 3.5 m × 3.5 m (L × W × H) shielded room. The EUT along with its peripherals were placed on a 1.0 m (W) × 1.5 m (L) and 0.8 m in height wooden table and the EUT was adjusted to maintain a 0.4 meter space from a vertical reference plane.
2. The EUT was connected to power mains through a line impedance stabilization network (LISN) which provides 50 ohm coupling impedance for measuring instrument and the chassis ground was bounded to the horizontal ground plane of shielded room.
3. All peripherals were connected to the second LISN and the chassis ground also bounded to the horizontal ground plane of shielded room.
4. The excess power cable between the EUT and the LISN was bundled. The power cables of peripherals were unbundled. All connecting cables of EUT and peripherals were moved to find the maximum emission.

The results shown in this test report refer only to the sample(s) tested unless otherwise stated. This test report cannot be reproduced, except in full, without prior written permission of the Company. This test report does not assure KOLAS accreditation.

4.4. Test Results

The following table shows the highest levels of conducted emissions on both phase of Hot and Neutral line.

Ambient temperature : (23 ± 1) °C
 Relative humidity : 47 % R.H.
 Frequency range : 0.15 MHz - 30 MHz
 Measured Bandwidth : 9 kHz

Test Condition: DC 5 V Operating mode with Client device (1 % battery status of client device)

Ant. 1

FREQ. (MHz)	LEVEL (dB μ V)		LINE	LIMIT (dB μ V)		MARGIN (dB)	
	Q-Peak	Average		Q-Peak	Average	Q-Peak	Average
0.63	28.50	19.90	N	56.00	46.00	27.50	26.10
1.37	34.90	29.20	N	56.00	46.00	21.10	16.80
1.87	33.00	27.50	N	56.00	46.00	23.00	18.50
2.62	29.60	22.70	N	56.00	46.00	26.40	23.30
14.37	27.30	20.60	N	60.00	50.00	32.70	29.40
18.40	26.60	16.50	N	60.00	50.00	33.40	33.50
0.37	30.10	23.90	H	58.50	48.50	28.40	24.60
1.13	30.50	24.70	H	56.00	46.00	25.50	21.30
1.37	31.70	26.50	H	56.00	46.00	24.30	19.50
1.63	31.60	25.70	H	56.00	46.00	24.40	20.30
2.13	33.70	25.60	H	56.00	46.00	22.30	20.40
16.12	25.70	18.60	H	60.00	50.00	34.30	31.40

Remark:

- Line (H): Hot, Line (N): Neutral
- Each charging mode with client device (1 %, 50 % and 99 % of battery) was tested. As worst condition, charging mode with client device (1 %) is reported.
- The limit for Class B device(s) from 150 kHz to 30 MHz are specified in Section of the Title 47 CFR.
- Traces shown in plot were made by using a peak detector and average detector.
- Deviations to the Specifications: None.

The results shown in this test report refer only to the sample(s) tested unless otherwise stated. This test report cannot be reproduced, except in full, without prior written permission of the Company. This test report does not assure KOLAS accreditation.

Test mode: (Neutral)

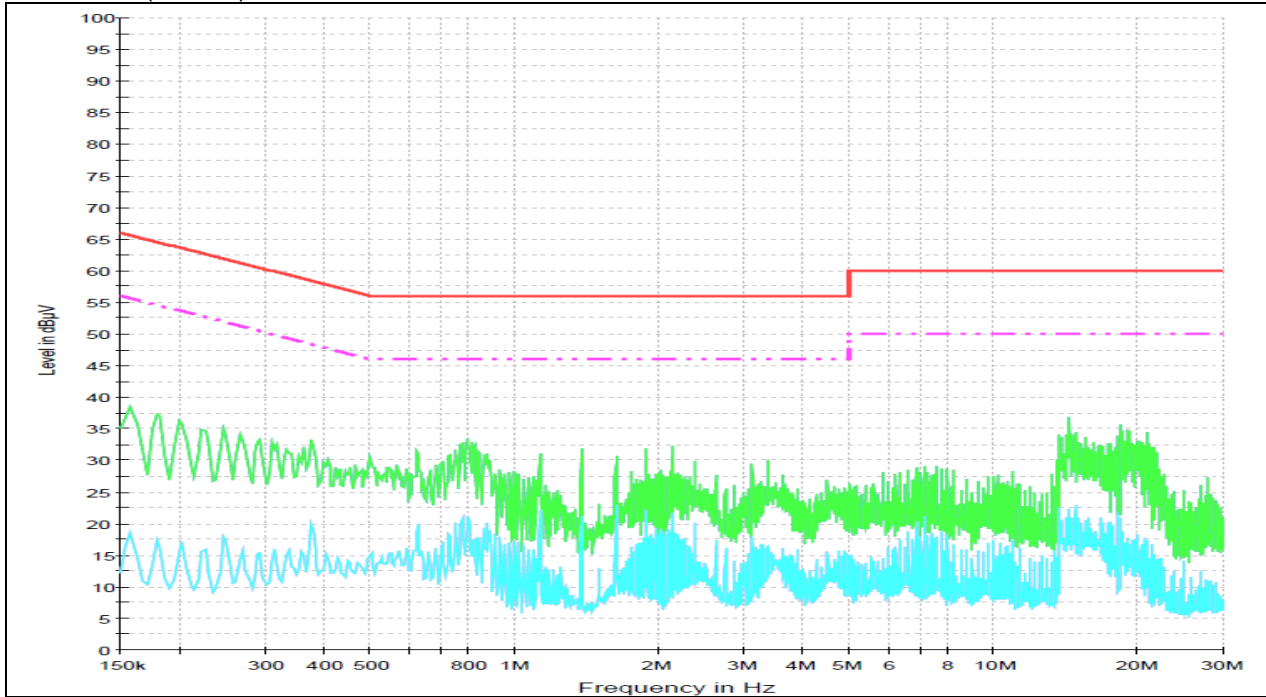

Test mode: (Hot)

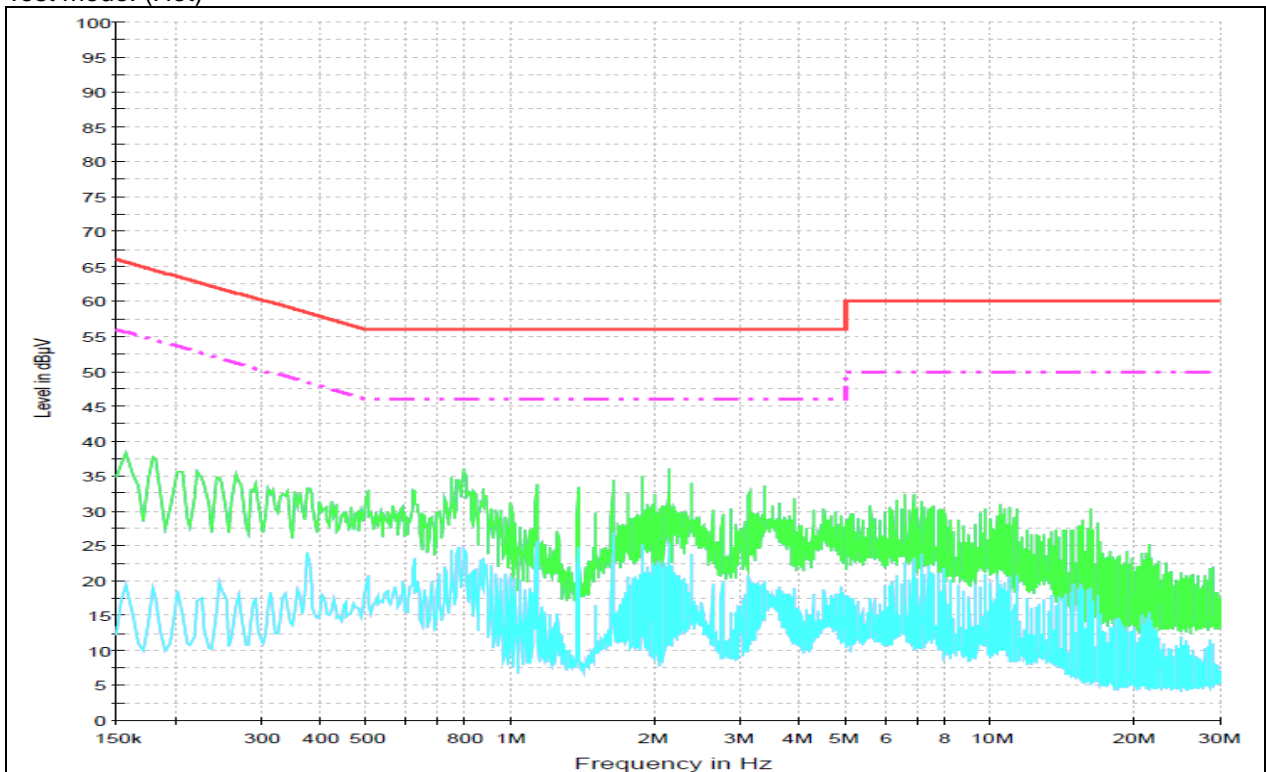

The results shown in this test report refer only to the sample(s) tested unless otherwise stated. This test report cannot be reproduced, except in full, without prior written permission of the Company. This test report does not assure KOLAS accreditation.

Ant. 2

FREQ. (MHz)	LEVEL (dB μ V)		LINE	LIMIT (dB μ V)		MARGIN (dB)	
	Q-Peak	Average		Q-Peak	Average	Q-Peak	Average
0.17	36.20	17.80	N	64.96	54.96	28.76	37.16
0.79	21.70	13.60	N	56.00	46.00	34.30	32.40
1.13	29.20	25.80	N	56.00	46.00	26.80	20.20
1.87	27.70	23.60	N	56.00	46.00	28.30	22.40
3.38	19.20	13.60	N	56.00	46.00	36.80	32.40
18.01	18.60	10.00	N	60.00	50.00	41.40	40.00
0.37	35.80	30.90	H	58.50	48.50	22.70	17.60
0.87	33.90	29.00	H	56.00	46.00	22.10	17.00
1.13	33.20	28.60	H	56.00	46.00	22.80	17.40
1.63	33.50	28.40	H	56.00	46.00	22.50	17.60
2.12	31.40	26.50	H	56.00	46.00	24.60	19.50
3.62	31.10	23.20	H	56.00	46.00	24.90	22.80

Remark:

1. Line (H): Hot, Line (N): Neutral
2. Each charging mode with client device (1 %, 50 % and 99 % of battery) was tested.
As worst condition, charging mode with client device (1 %) is reported.
3. The limit for Class B device(s) from 150 kHz to 30 MHz are specified in Section of the Title 47 CFR.
4. Traces shown in plot were made by using a peak detector and average detector.
5. Deviations to the Specifications: None.

The results shown in this test report refer only to the sample(s) tested unless otherwise stated. This test report cannot be reproduced, except in full, without prior written permission of the Company. This test report does not assure KOLAS accreditation.

Test mode: (Neutral)

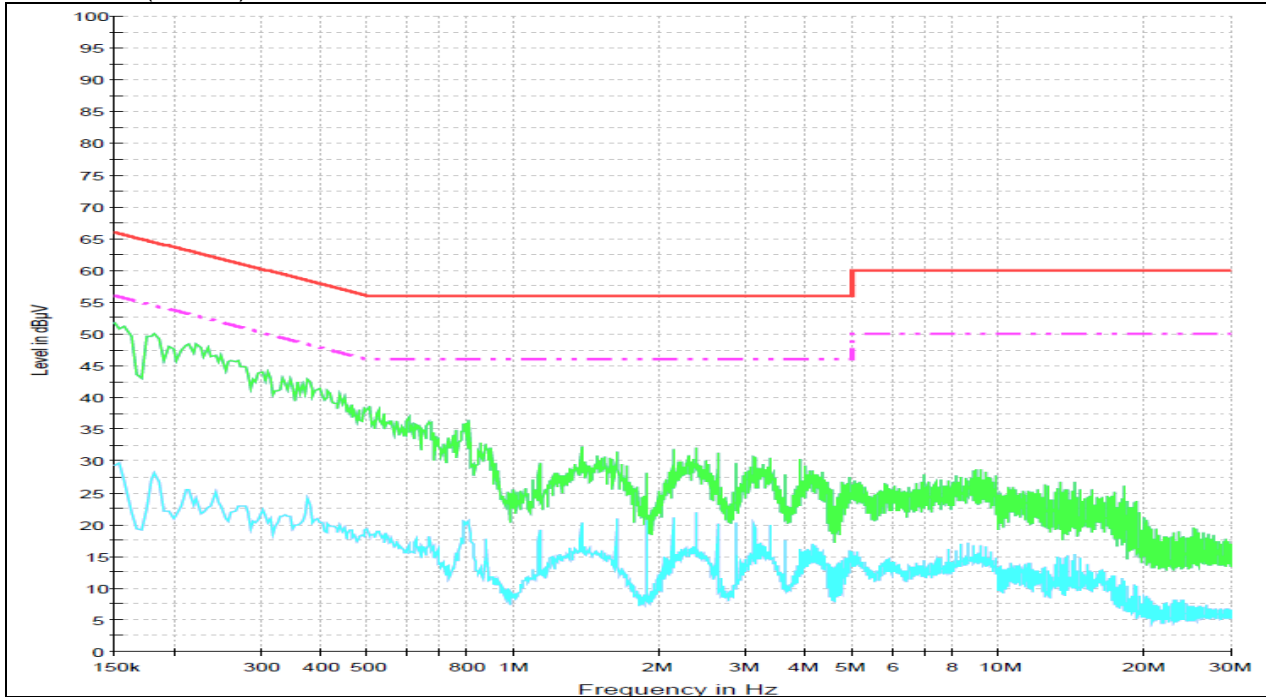

Test mode: (Hot)

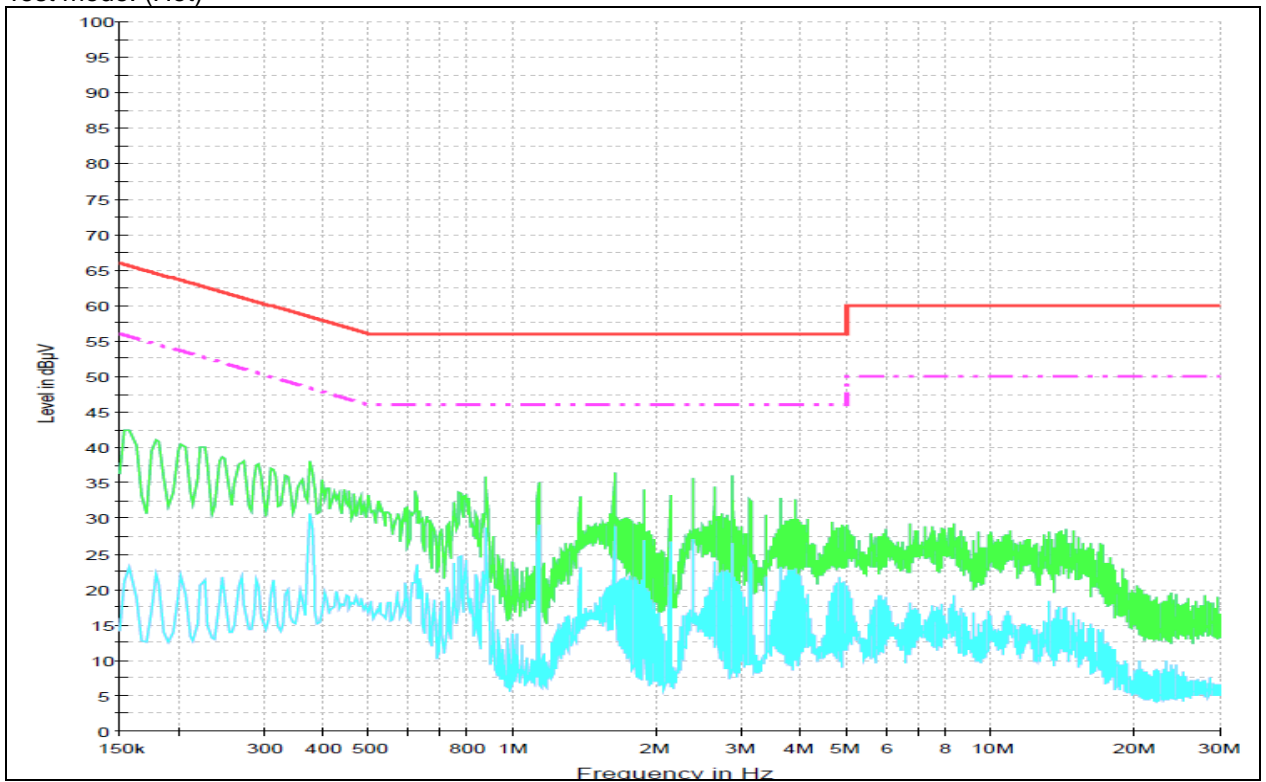

The results shown in this test report refer only to the sample(s) tested unless otherwise stated. This test report cannot be reproduced, except in full, without prior written permission of the Company. This test report does not assure KOLAS accreditation.

Test Condition: DC 9 V Operating mode with Client device (1 % battery status of client device)

Ant. 1

FREQ. (MHz)	LEVEL (dB μ V)		LINE	LIMIT (dB μ V)		MARGIN (dB)	
	Q-Peak	Average		Q-Peak	Average	Q-Peak	Average
0.68	31.30	25.20	N	56.00	46.00	24.70	20.80
0.95	30.00	26.00	N	56.00	46.00	26.00	20.00
1.23	32.40	27.60	N	56.00	46.00	23.60	18.40
2.05	32.60	27.10	N	56.00	46.00	23.40	18.90
2.59	28.50	22.30	N	56.00	46.00	27.50	23.70
18.99	27.10	14.70	N	60.00	50.00	32.90	35.30
0.41	36.30	28.90	H	57.65	47.65	21.35	18.75
0.62	37.50	29.50	H	56.00	46.00	18.50	16.50
0.84	40.00	31.30	H	56.00	46.00	16.00	14.70
2.32	37.90	31.00	H	56.00	46.00	18.10	15.00
5.85	37.00	29.40	H	60.00	50.00	23.00	20.60
13.49	37.70	28.80	H	60.00	50.00	22.30	21.20

Remark:

1. Line (H): Hot, Line (N): Neutral
2. Each charging mode with client device (1 %, 50 % and 99 % of battery) was tested. As worst condition, charging mode with client device (1 %) is reported.
3. The limit for Class B device(s) from 150 kHz to 30 MHz are specified in Section of the Title 47 CFR.
4. Traces shown in plot were made by using a peak detector and average detector.
5. Deviations to the Specifications: None.

The results shown in this test report refer only to the sample(s) tested unless otherwise stated. This test report cannot be reproduced, except in full, without prior written permission of the Company. This test report does not assure KOLAS accreditation.

Test mode: (Neutral)

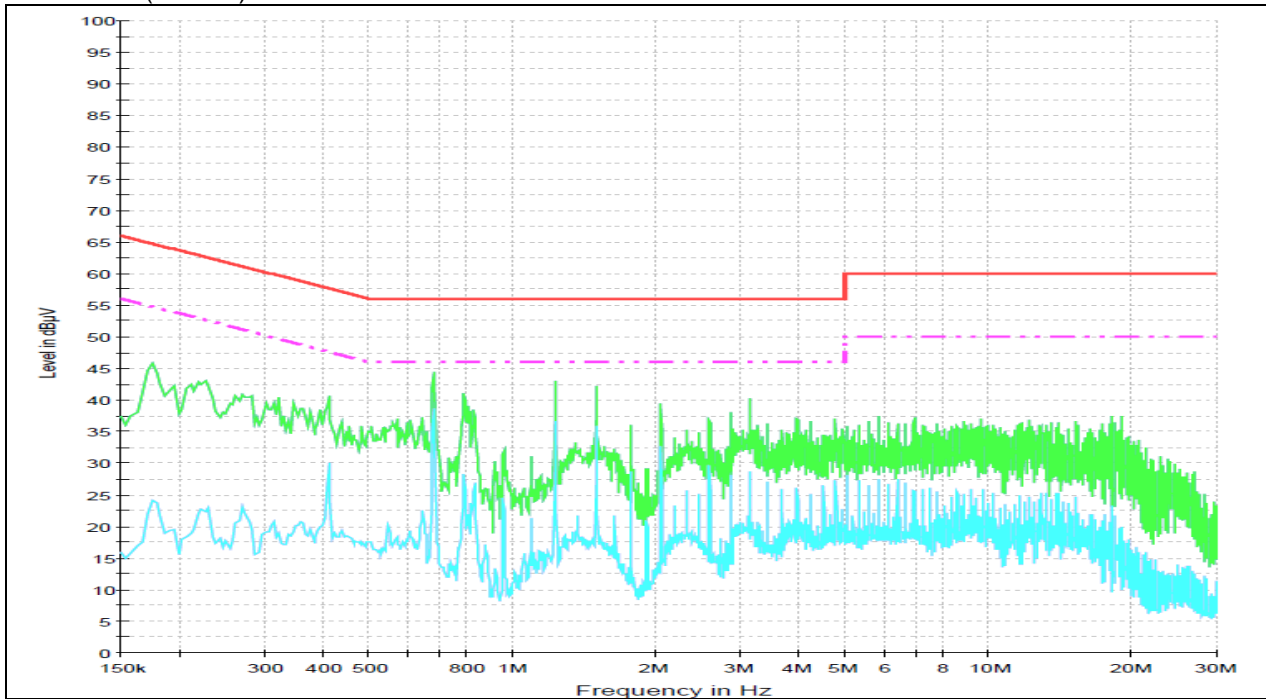

Test mode: (Hot)

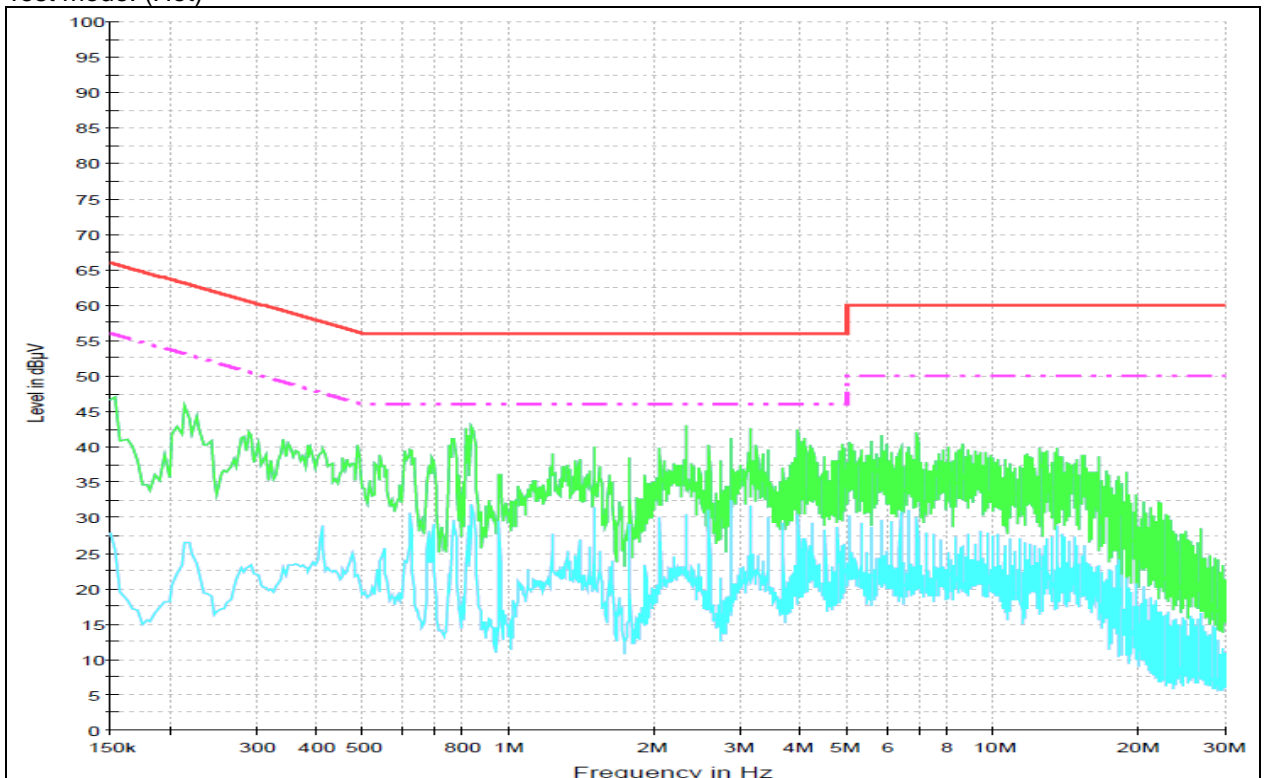

- End of the Test Report -

The results shown in this test report refer only to the sample(s) tested unless otherwise stated. This test report cannot be reproduced, except in full, without prior written permission of the Company. This test report does not assure KOLAS accreditation.