

TEST REPORT

of

FCC Part 15 Subpart C §15.209

FCC ID: A3LEPP1300

Equipment Under Test : WIRELESS CHARGER
Model Name : EP-P1300
Variant Model Name(s) : -
Applicant : Samsung Electronics Co., Ltd.
Manufacturer : Samsung Electronics Co., Ltd.
Date of Receipt : 2020.11.04
Date of Test(s) : 2020.11.17 ~ 2020.12.03
Date of Issue : 2020.12.16

In the configuration tested, the EUT complied with the standards specified above. This test report does not assure KOLAS accreditation.

- 1) The results of this test report are effective only to the items tested.
- 2) The SGS Korea is not responsible for the sampling, the results of this test report apply to the sample as received.
- 3) This test report cannot be reproduced, except in full, without prior written permission of the Company.

Tested by:



Jinhyoung Cho

Technical
Manager:



Hyunchoe You

SGS Korea Co., Ltd. Gunpo Laboratory



INDEX

Table of Contents

| | |
|--|----|
| 1. General Information ----- | 3 |
| 2. Field Strength of Fundamental and Spurious Emission ----- | 7 |
| 3. 20 dB Bandwidth ----- | 27 |
| 4. AC Power Line Conducted Emission ----- | 30 |

1. General Information

1.1. Testing Laboratory

SGS Korea Co., Ltd. (Gunpo Laboratory)

- 10-2, LS-ro 182beon-gil, Gunpo-si, Gyeonggi-do, Korea, 15807
- 4, LS-ro 182beon-gil, Gunpo-si, Gyeonggi-do, Korea, 15807

All SGS services are rendered in accordance with the applicable SGS conditions of service available on request and accessible at <http://www.sgs.com/en/Terms-and-Conditions.aspx>.

Phone No. : +82 31 688 0901

Fax No. : +82 31 688 0921

1.2. Details of Applicant

Applicant : Samsung Electronics Co., Ltd.
 Address : 19 Chapin Rd., Building D, Pine Brook, New Jersey, United States, 07058
 Contact Person : Chun, Jenni
 Phone No. : +1 973 808 6362

1.3. Details of Manufacturer

Company : Samsung Electronics Co., Ltd.
 Address : Yen Phong 1 Industrial park, Yen Phong District Bac Ninh Province, VIETNAM

1.4. Description of EUT

| | |
|--------------------------|------------------------|
| Kind of Product | WIRELESS CHARGER |
| Model Name | EP-P1300 |
| Power Supply | DC 9.0 V |
| Operation Mode | 2 W, 4.5 W, 7.5 W, 9W |
| Frequency Range | 126.2 kHz ~ 129.2 kHz |
| Antenna Type | Loop Coil Antenna |
| H/W Version | rev.03 |
| S/W Version_MCU | EP-P1300_20201111_8F5C |
| S/W Version_Tx IC | P13_PRA_OFFI_1208 |

1.5. Test Equipment List

| Equipment | Manufacturer | Model | S/N | Cal. Date | Cal. Interval | Cal. Due |
|--------------------|--------------------------------|--------------------------------------|---------------------------|---------------|---------------|---------------|
| Spectrum Analyzer | R&S | FSV30 | 103210 | Dec. 07, 2020 | Annual | Dec. 07, 2021 |
| Signal Generator | R&S | SMBV100A | 255834 | Jun. 03, 2020 | Annual | Jun. 03, 2021 |
| Amplifier | H.P. | 8447F | 2944A03909 | Aug. 06, 2020 | Annual | Aug. 06, 2021 |
| Loop Antenna | Schwarzbeck Mess-Elektronik | FMZB 1519 | 1519-039 | Aug. 22, 2019 | Biennial | Aug. 22, 2021 |
| Bilog Antenna | Schwarzbeck Mess-Elektronik | VULB9163 | 396 | Mar. 21, 2019 | Biennial | Mar. 21, 2021 |
| Test Receiver | R&S | ESU26 | 100109 | Feb. 18, 2020 | Annual | Feb. 18, 2021 |
| Turn Table | Innco systems GmbH | DS 1200 S | N/A | N.C.R. | N/A | N.C.R. |
| Controller | Innco systems GmbH | CONTROLLER CO3000-4P | CO3000/963/38 330516/L | N.C.R. | N/A | N.C.R. |
| Anechoic Chamber | SY Corporation | L x W x H (9.6 m x 6.4 m x 6.6 m) | N/A | N.C.R. | N/A | N.C.R. |
| Coaxial Cable | RFONE | MWX221-NMSNMS (4 m) | J1023142 | Dec. 01, 2020 | Semi-annual | Jun. 01, 2021 |
| Coaxial Cable | RFONE | PL520-NMNM-10M (10 m) | 20200324001 | Aug. 10, 2020 | Semi-Annual | Feb. 10, 2021 |
| Test Receiver | R&S | ESCI 7 | 100911 | Feb. 19, 2020 | Annual | Feb. 19, 2021 |
| Two-Line V-Network | R&S | ENV216 | 100190 | May 08, 2020 | Annual | May 08, 2021 |
| Shield Room | SY Corporation | L x W x H (6.5 m x 3.5 m x 3.5 m) | N/A | N.C.R. | N/A | N.C.R. |

► Support Equipment

| Description | Manufacturer | Model | FCC ID |
|----------------------|-------------------------------|----------|---------------------------|
| Samsung Mobile Phone | Samsung Electronics Co., Ltd. | SM-G970 | A3LSMG970U |
| | | SM-G973U | A3LSMG973U |
| Bluetooth Headset | Samsung Electronics Co., Ltd. | SM-R170 | A3LSMR170L, A3LSMR170R |
| C type USB Cable | Samsung Electronics Co., Ltd. | EP-DW720 | - |
| TRAVEL ADAPTER | DONGYANG E&P | EP-TA200 | - |

1.6. Sample Calculation

Where relevant, the following sample calculation is provided:

$$\text{Field strength level (dB}\mu\text{V/m)} = \text{Measured level (dB}\mu\text{V)} + \text{Antenna factor (dB)} + \text{Cable loss (dB)} + \text{(AMP (dB))}$$

1.7. Worst Case of Test Configurations

| Charging mode with client device | Mode | | | | Description |
|---|--------------------------|--------------------------|--------------------------|--------------------------|--|
| Model: SM-G970U FCC ID: A3LSMG970U | 2 W | 4.5 W | 7.5 W | 9 W | 1 % of battery 50 % of battery 99 % of battery |
| Model: SM-G973U FCC ID: A3LSMG973U | 126.2 kHz ~ 129.2 kHz | 126.2 kHz ~ 129.2 kHz | 126.2 kHz ~ 129.2 kHz | 126.2 kHz ~ 129.2 kHz | |
| Model: SM-R170 FCC ID: A3LSMR170L, A3LSMR170R | SM-R170 | SM-G970U (Normal) | SM-G970U (Fast) | SM-G973U | |

Note;

The 4.5 W and 7.5 W modes are controlled by the software on the client device.

EUT was investigated with client device under normal charging condition as above then worst value was only reported.

1.8. Summary of Test Results

The EUT has been tested according to the following specifications:

| APPLIED STANDARD: FCC Part 15 Subpart C | | |
|--|--|----------|
| Section | Test Item(s) | Result |
| 15.209 | Radiated Emission, Spurious Emission and Field Strength of Fundamental | Complied |
| 2.1049 | 20 dB Bandwidth | Complied |
| 15.207 | AC Power Line Conducted Emission | Complied |

Note;

Due to the frequency range of the device is less than 1 MHz, so we perform Middle frequency according to 15.31 requirement.

1.9. Measurement Uncertainty

Where relevant, the following measurement uncertainty levels have been estimated for tests performed on the apparatus:

| Parameter | Uncertainty |
|---------------------------------------|-------------|
| 20 dB Bandwidth | ± 9.66 kHz |
| AC Conducted Emission | ± 3.45 dB |
| Radiated Disturbance, 9 kHz to 30 MHz | ± 3.59 dB |
| Radiated Disturbance, below 1 GHz | ± 5.88 dB |

Uncertainty figures are valid to a confidence level of 95 %.

1.10. Test Report Revision

| Revision | Report Number | Date of Issue | Description |
|----------|------------------------|---------------|---|
| 0 | F690501-RF-RTL001435 | 2020.12.09 | Initial |
| 1 | F690501-RF-RTL001435-1 | 2020.12.14 | Added the information of H/W Version and S/W Version. |
| 2 | F690501-RF-RTL001435-2 | 2020.12.16 | Added the test mode to indicate what kind of client device is used. |

2. Field Strength of Fundamental and Spurious Emission

2.1. Test Setup

The diagram below shows the test setup that is utilized to make the measurements for emission from 9 MHz to 30 MHz.

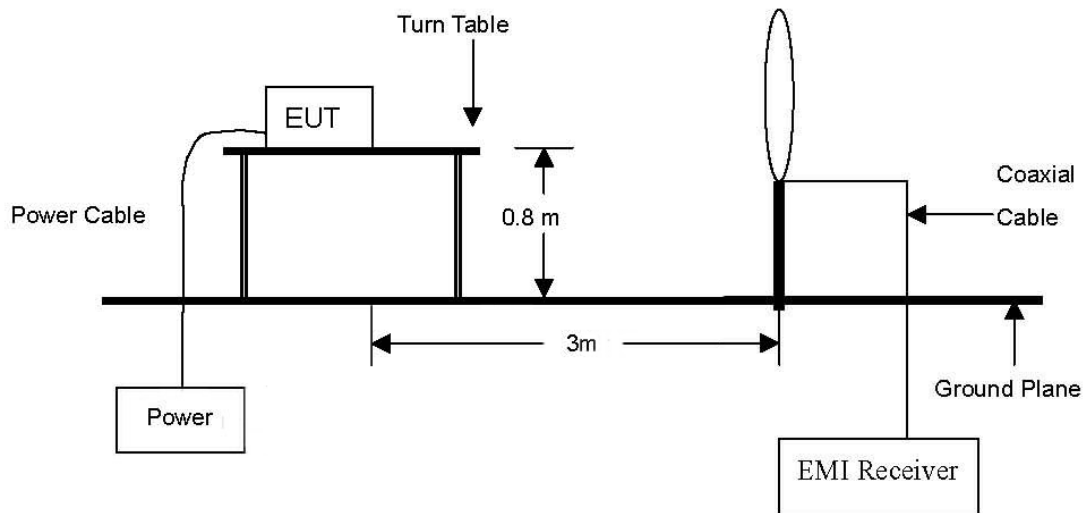

The diagram below shows the test setup that is utilized to make the measurements for emission from 30 MHz to 1 GHz.

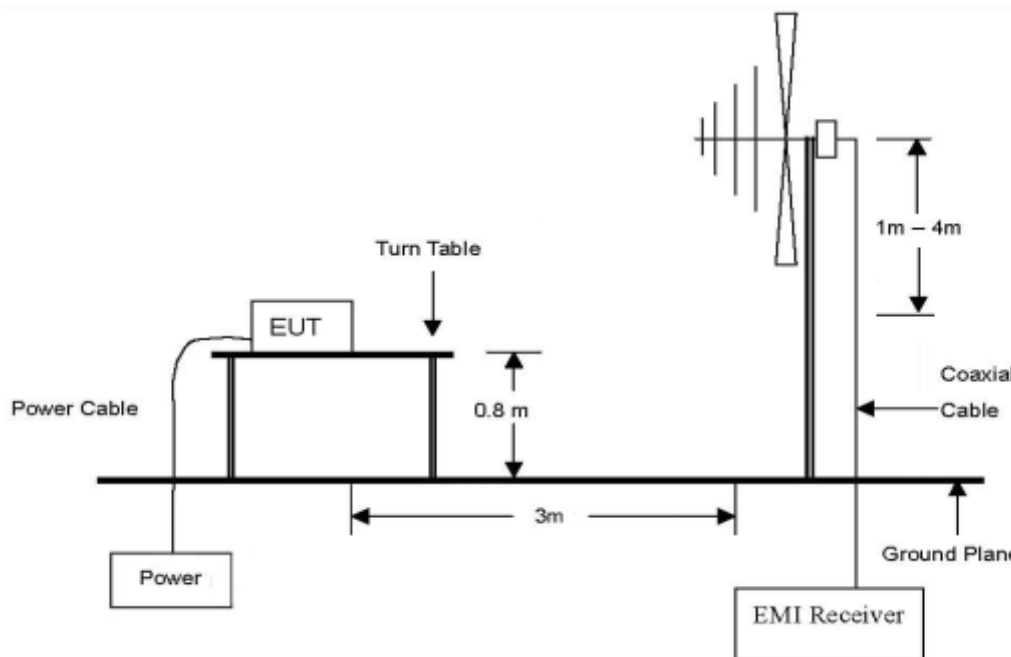

2.2. Limit

2.2.1. Radiated emission limits, general requirements

According to §15.209(a), except as provided elsewhere in this subpart, the emissions from an intentional radiator shall not exceed the field strength levels specified in the following table:

| Frequency (MHz) | Field Strength (microvolts/meter) | Measurement Distance (meter) |
|--------------------|--------------------------------------|---------------------------------|
| 0.009-0.490 | 2 400/F(kHz) | 300 |
| 0.490-1.705 | 24 000/F(kHz) | 30 |
| 1.705-30.0 | 30 | 30 |
| 30-88 | 100** | 3 |
| 88-216 | 150** | 3 |
| 216-960 | 200** | 3 |
| Above 960 | 500 | 3 |

** Except as provided in paragraph (g), fundamental emissions from intentional radiators operating under this section shall not be located in the frequency bands 54-72 MHz, 76-88 MHz, 174-216 MHz or 470-806 MHz. however, operation within these frequency bands is permitted under other sections of this part, e.g., §§15.231 and 15.241

2.3. Test Procedures

Radiated emissions from the EUT were measured according to the dictates of ANSI C63.10:2013.

2.3.1. Test Procedures for emission from 9 kHz to 30 MHz

- a. The EUT was placed on the top of a rotating table 0.8 meters above the ground at a 3 meter anechoic chamber test site. The table was rotated 360 degrees to determine the position of the highest radiation.
- b. Then antenna is a loop antenna is fixed at one meter above the ground to determine the maximum value of the field strength. Both parallel and perpendicular of the antenna are set to make the measurement.
- c. For each suspected emission, the EUT was arranged to its worst case and then the table was turned from 0 degrees to 360 degrees to find the maximum reading.
- d. The test-receiver system was set to Quasi Peak and Average Detect Function and Specified Bandwidth with Maximum Hold Mode.

2.3.2. Test Procedures for emission from 30 MHz to 1 000 MHz

- a. The EUT was placed on the top of a rotating table 0.8 meters above the ground at a 3 meter anechoic chamber test site. The table was rotated 360 degrees to determine the position of the highest radiation.
- b. During performing radiated emission below 1 GHz, the EUT was set 3 meters away from the interference receiving antenna, which was mounted on the top of a variable-height antenna tower. During performing radiated emission above 1 GHz, the EUT was set 3 meter away from the interference-receiving antenna.
- c. The antenna is a broadband antenna, and its height is varied from one meter to four meters above the ground to determine the maximum value of the field strength. Both horizontal and vertical polarizations of the antenna are set to make the measurement.
- d. For each suspected emission, the EUT was arranged to its worst case and then the antenna was tuned to heights from 1 meter to 4 meters and the table was turned from 0 degrees to 360 degrees to find the maximum reading.
- e. The test-receiver system was set to Peak Detect Function and Specified Bandwidth with Maximum Hold Mode.

2.4. Field Strength of Fundamental Test Result

Ambient temperature : (23 ± 1) °C
 Relative humidity : 47 % R.H.

The following table shows the highest levels of radiated emissions on between polarizations of horizontal and vertical.

Test Condition: 2 W Operating mode with client device (1 % battery status of client device)

| Radiated Emissions | | | Ant. | Correction Factors | | Total | | Limit | |
|--------------------------------|----------------------|-------------|------|--------------------|---------|------------------------------|--------------------------------|-------------------------------|-------------|
| Frequency (MHz) | Reading (dB μ V) | Detect Mode | Pol. | AF (dB/m) | CL (dB) | Actual (dB μ V/m) at 3 m | Actual (dB μ V/m) at 300 m | Limit (dB μ V/m) at 300 m | Margin (dB) |
| Ant. 1 (126.2 kHz ~ 129.2 kHz) | | | | | | | | | |
| 0.128 | 57.30 | Average | H | 17.80 | 0.15 | 75.25 | -4.75 | 25.46 | 30.21 |

Test Condition: 4.5 W Operating mode with client device (1 % battery status of client device)

| Radiated Emissions | | | Ant. | Correction Factors | | Total | | Limit | |
|--------------------------------|----------------------|-------------|------|--------------------|---------|------------------------------|--------------------------------|-------------------------------|-------------|
| Frequency (MHz) | Reading (dB μ V) | Detect Mode | Pol. | AF (dB/m) | CL (dB) | Actual (dB μ V/m) at 3 m | Actual (dB μ V/m) at 300 m | Limit (dB μ V/m) at 300 m | Margin (dB) |
| Ant. 1 (126.2 kHz ~ 129.2 kHz) | | | | | | | | | |
| 0.128 | 60.90 | Average | H | 17.80 | 0.15 | 78.85 | -1.15 | 25.46 | 26.61 |

Test Condition: 7.5 W Operating mode with client device (1 % battery status of client device)

| Radiated Emissions | | | Ant. | Correction Factors | | Total | | Limit | |
|--------------------------------|----------------------|-------------|------|--------------------|---------|------------------------------|--------------------------------|-------------------------------|-------------|
| Frequency (MHz) | Reading (dB μ V) | Detect Mode | Pol. | AF (dB/m) | CL (dB) | Actual (dB μ V/m) at 3 m | Actual (dB μ V/m) at 300 m | Limit (dB μ V/m) at 300 m | Margin (dB) |
| Ant. 1 (126.2 kHz ~ 129.2 kHz) | | | | | | | | | |
| 0.128 | 62.30 | Average | H | 17.80 | 0.15 | 80.25 | 0.25 | 25.46 | 25.21 |

Test Condition: 9 W Operating mode with client device (1 % battery status of client device)

| Radiated Emissions | | | Ant. | Correction Factors | | Total | | Limit | |
|--------------------------------|----------------------|-------------|------|--------------------|---------|------------------------------|--------------------------------|-------------------------------|-------------|
| Frequency (MHz) | Reading (dB μ V) | Detect Mode | Pol. | AF (dB/m) | CL (dB) | Actual (dB μ V/m) at 3 m | Actual (dB μ V/m) at 300 m | Limit (dB μ V/m) at 300 m | Margin (dB) |
| Ant. 1 (126.2 kHz ~ 129.2 kHz) | | | | | | | | | |
| 0.128 | 67.30 | Average | H | 17.80 | 0.15 | 85.25 | <u>5.25</u> | 25.46 | 20.21 |

Remark;

1. According to §15.31(f)(2),
 - 300 m Result (dB μ N/m) = 3 m Result (dB μ N/m) - 40log (300/3) (dB μ N/m).
2. According to field strength table of general requirement in §15.209(a), field strength limits below 1.705 MHz were calculated as below.
 - 9 kHz to 490 kHz: 20log (2 400 / F (kHz)) at 300 m (dB μ N/m)
 - 490 kHz to 1.705 MHz: 20log (24 000/F (kHz)) at 30 m (dB μ N/m)
3. According to §15.209(d), the measurements were tested by using Quasi peak detector except for the frequency bands 9-90 kHz, 110-490 kHz and above 1 GHz in these three bands on measurements employing an average detector.
4. The limit above was calculated based on table of §15.209(a).

- Test plots

Test Condition: 2 W Operating mode with client device (1 % battery status of client device)

Ant. 1 (126.2 kHz ~ 129.2 kHz)

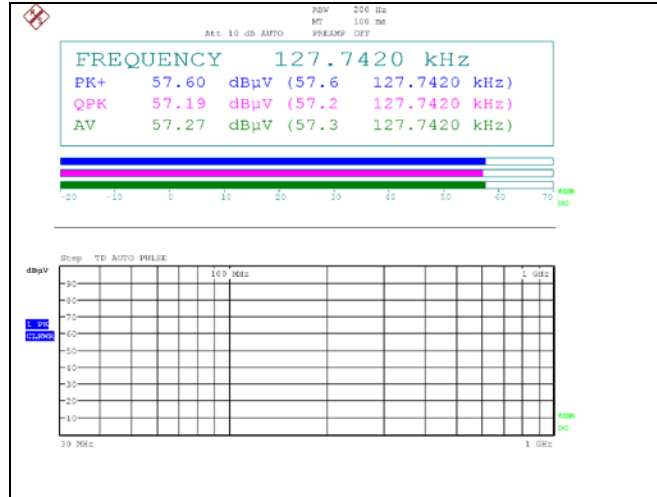

Test Condition: 4.5 W Operating mode with client device (1 % battery status of client device)

Ant. 1 (126.2 kHz ~ 129.2 kHz)

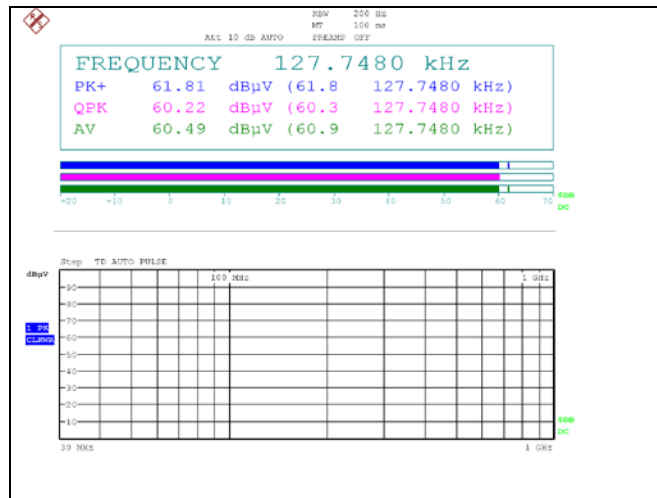

Test Condition: 7.5 W Operating mode with client device (1 % battery status of client device)

Ant. 1 (126.2 kHz ~ 129.2 kHz)

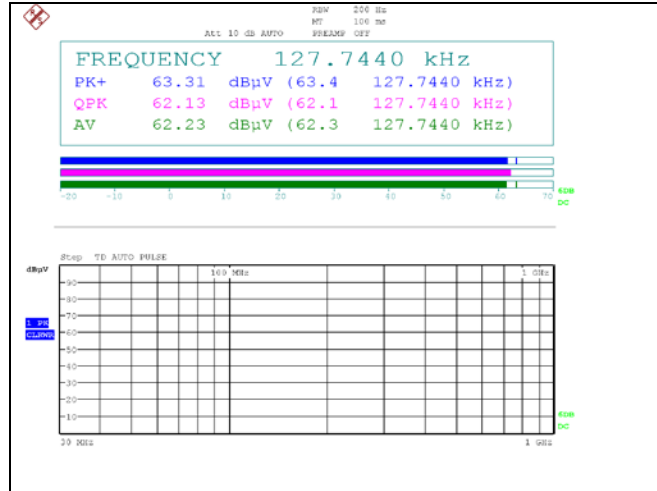

Test Condition: 9 W Operating mode with client device (1 % battery status of client device)

Ant. 1 (126.2 kHz ~ 129.2 kHz)

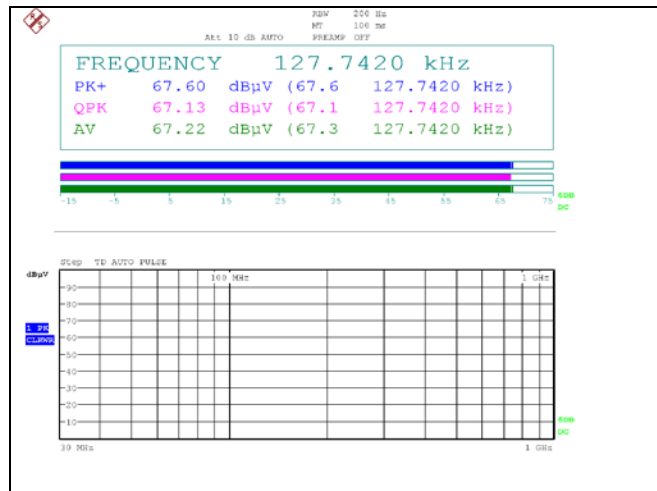

2.5. Spurious Emission Test Result

Ambient temperature : (23 ± 1) °C
 Relative humidity : 47 % R.H.

The following table shows the highest levels of radiated emissions on between polarizations of horizontal and vertical.

Test Condition: 2 W Operating mode with client device (1 % battery status of client device)

Ant. 1 (126.2 kHz ~ 129.2 kHz)

Below 30 MHz

| Radiated Emissions | | | Ant. | Correction Factors | | Total | | Limit | |
|--------------------|----------------|-------------|------|--------------------|---------|------------------------|----------------------------------|---------------------------------|-------------|
| Frequency (MHz) | Reading (dBμV) | Detect Mode | Pol. | AF (dB/m) | CL (dB) | Actual (dBμV/m) at 3 m | Actual (dBμV/m) at 300 m or 30 m | Limit (dBμV/m) at 300 m or 30 m | Margin (dB) |
| 0.018 | 30.30 | Average | H | 18.26 | 0.10 | 48.66 | -31.34 | 42.50 | 73.84 |
| 0.036 | 34.20 | Average | H | 17.89 | 0.11 | 52.20 | -27.80 | 36.48 | 64.28 |
| 0.383 | 31.80 | Average | H | 17.76 | 0.17 | 49.73 | -30.27 | 15.94 | 46.21 |

Above 30 MHz

| Radiated Emissions | | | Ant | Correction Factors | | Total | Limit | |
|--------------------|----------------|-------------|------|--------------------|---------------|-----------------|----------------|-------------|
| Frequency (MHz) | Reading (dBμV) | Detect Mode | Pol. | AF (dB/m) | AMP + CL (dB) | Actual (dBμV/m) | Limit (dBμV/m) | Margin (dB) |
| 48.24 | 36.60 | Peak | V | 20.45 | -27.25 | 29.80 | 40.00 | 10.20 |
| 53.33 | 43.70 | Peak | V | 19.73 | -27.20 | 36.23 | 40.00 | 3.77 |
| 71.32 | 43.40 | Peak | V | 13.90 | -27.00 | 30.30 | 40.00 | 9.70 |
| 227.40 | 40.80 | Peak | H | 17.65 | -25.51 | 32.94 | 46.00 | 13.06 |
| 329.88 | 36.40 | Peak | H | 19.99 | -25.11 | 31.28 | 46.00 | 14.72 |
| 405.00 | 33.30 | Peak | H | 21.70 | -25.53 | 29.47 | 46.00 | 16.53 |
| Above 500.00 | Not detected | - | - | - | - | - | - | - |

Test Condition: 4.5 W Operating mode with client device (1 % battery status of client device)

Ant. 1 (126.2 kHz ~ 129.2 kHz)

Below 30 MHz

| Radiated Emissions | | | Ant. | Correction Factors | | Total | | Limit | |
|--------------------|----------------------|-------------|------|--------------------|---------|------------------------------|--|---------------------------------------|-------------|
| Frequency (MHz) | Reading (dB μ V) | Detect Mode | Pol. | AF (dB/m) | CL (dB) | Actual (dB μ V/m) at 3 m | Actual (dB μ V/m) at 300 m or 30 m | Limit (dB μ V/m) at 300 m or 30 m | Margin (dB) |
| 0.019 | 31.80 | Average | H | 18.23 | 0.10 | 50.13 | -29.87 | 42.03 | 71.90 |
| 0.036 | 35.20 | Average | H | 17.89 | 0.11 | 53.20 | -26.80 | 36.48 | 63.28 |
| 0.384 | 40.70 | Average | H | 17.76 | 0.17 | 58.63 | -21.37 | 15.92 | 37.29 |
| 0.639 | 31.93 | Quasi Peak | H | 17.81 | 0.18 | 49.92 | 9.92 | 31.49 | 21.57 |
| 0.893 | 26.43 | Quasi Peak | H | 18.01 | 0.19 | 44.63 | 4.63 | 28.59 | 23.96 |

Above 30 MHz

| Radiated Emissions | | | Ant. | Correction Factors | | Total | Limit | |
|--------------------|----------------------|-------------|------|--------------------|---------------|-----------------------|----------------------|-------------|
| Frequency (MHz) | Reading (dB μ V) | Detect Mode | Pol. | AF (dB/m) | AMP + CL (dB) | Actual (dB μ V/m) | Limit (dB μ V/m) | Margin (dB) |
| 45.03 | 32.70 | Quasi Peak | V | 20.60 | -27.27 | 26.03 | 40.00 | 13.97 |
| 53.33 | 43.80 | Peak | V | 19.73 | -27.20 | 36.33 | 40.00 | 3.67 |
| 55.17 | 43.40 | Peak | V | 19.35 | -27.19 | 35.56 | 40.00 | 4.44 |
| 227.64 | 42.60 | Peak | H | 17.65 | -25.50 | 34.75 | 46.00 | 11.25 |
| 321.73 | 38.10 | Peak | H | 19.57 | -25.12 | 32.55 | 46.00 | 13.45 |
| 404.42 | 35.40 | Peak | H | 21.69 | -25.53 | 31.56 | 46.00 | 14.44 |
| Above 500.00 | Not detected | - | - | - | - | - | - | - |

Test Condition: 7.5 W Operating mode with client device (1 % battery status of client device)

Ant. 1 (126.2 kHz ~ 129.2 kHz)

Below 30 MHz

| Radiated Emissions | | | Ant. | Correction Factors | | Total | | Limit | |
|--------------------|----------------------|-------------|------|--------------------|---------|------------------------------|--|---------------------------------------|-------------|
| Frequency (MHz) | Reading (dB μ V) | Detect Mode | Pol. | AF (dB/m) | CL (dB) | Actual (dB μ V/m) at 3 m | Actual (dB μ V/m) at 300 m or 30 m | Limit (dB μ V/m) at 300 m or 30 m | Margin (dB) |
| 0.019 | 27.80 | Average | H | 18.23 | 0.10 | 46.13 | -33.87 | 42.03 | 75.90 |
| 0.036 | 34.90 | Average | H | 17.89 | 0.11 | 52.90 | -27.10 | 36.48 | 63.58 |
| 0.383 | 42.70 | Average | H | 17.76 | 0.17 | 60.63 | -19.37 | 15.94 | 35.31 |
| 0.638 | 34.20 | Quasi Peak | H | 17.81 | 0.18 | 52.19 | 12.19 | 31.51 | 19.32 |
| 0.895 | 29.00 | Quasi Peak | H | 18.02 | 0.19 | 47.21 | 7.21 | 28.57 | 21.36 |

Above 30 MHz

| Radiated Emissions | | | Ant. | Correction Factors | | Total | Limit | |
|--------------------|----------------------|-------------|------|--------------------|---------------|-----------------------|----------------------|-------------|
| Frequency (MHz) | Reading (dB μ V) | Detect Mode | Pol. | AF (dB/m) | AMP + CL (dB) | Actual (dB μ V/m) | Limit (dB μ V/m) | Margin (dB) |
| 43.85 | 36.70 | Quasi Peak | V | 20.49 | -27.28 | 29.91 | 40.00 | 10.09 |
| 53.32 | 42.40 | Quasi Peak | V | 19.74 | -27.20 | 34.94 | 40.00 | 5.06 |
| 63.22 | 45.30 | Peak | V | 17.03 | -27.09 | 35.24 | 40.00 | 4.76 |
| 227.78 | 40.70 | Peak | H | 17.66 | -25.50 | 32.86 | 46.00 | 13.14 |
| 324.06 | 37.40 | Peak | H | 19.66 | -25.11 | 31.95 | 46.00 | 14.05 |
| 402.63 | 34.80 | Peak | H | 21.65 | -25.52 | 30.93 | 46.00 | 15.07 |
| Above 500.00 | Not detected | - | - | - | - | - | - | - |

Test Condition: 9 W Operating mode with client device (1 % battery status of client device)

Ant. 1 (126.2 kHz ~ 129.2 kHz)

Below 30 MHz

| Radiated Emissions | | | Ant. | Correction Factors | | Total | | Limit | |
|--------------------|----------------------|-------------|------|--------------------|---------|------------------------------|--|---------------------------------------|-------------|
| Frequency (MHz) | Reading (dB μ V) | Detect Mode | Pol. | AF (dB/m) | CL (dB) | Actual (dB μ V/m) at 3 m | Actual (dB μ V/m) at 300 m or 30 m | Limit (dB μ V/m) at 300 m or 30 m | Margin (dB) |
| 0.018 | 28.70 | Average | H | 18.26 | 0.10 | 47.06 | -32.94 | 42.50 | 75.44 |
| 0.035 | 34.80 | Average | H | 17.89 | 0.11 | 52.80 | -27.20 | 36.72 | 63.92 |
| 0.384 | 44.70 | Average | H | 17.76 | 0.17 | 62.63 | -17.37 | 15.92 | 33.29 |
| 0.638 | 33.00 | Quasi Peak | H | 17.81 | 0.18 | 50.99 | 10.99 | 31.51 | 20.52 |
| 0.893 | 23.90 | Quasi Peak | H | 18.01 | 0.19 | 42.10 | 2.10 | 28.59 | 26.49 |

Above 30 MHz

| Radiated Emissions | | | Ant. | Correction Factors | | Total | Limit | |
|--------------------|----------------------|-------------|------|--------------------|---------------|-----------------------|----------------------|-------------|
| Frequency (MHz) | Reading (dB μ V) | Detect Mode | Pol. | AF (dB/m) | AMP + CL (dB) | Actual (dB μ V/m) | Limit (dB μ V/m) | Margin (dB) |
| 43.10 | 39.70 | Peak | V | 20.41 | -27.28 | 32.83 | 40.00 | 7.17 |
| 47.36 | 41.30 | Peak | V | 20.56 | -27.25 | 34.61 | 40.00 | 5.39 |
| 53.32 | 43.10 | Quasi Peak | V | 19.74 | -27.20 | 35.64 | 40.00 | 4.36 |
| 228.17 | 40.30 | Peak | H | 17.66 | -25.50 | 32.46 | 46.00 | 13.54 |
| 318.77 | 37.80 | Peak | H | 19.48 | -25.11 | 32.17 | 46.00 | 13.83 |
| 405.63 | 34.90 | Peak | H | 21.71 | -25.53 | 31.08 | 46.00 | 14.92 |
| Above 500.00 | Not detected | - | - | - | - | - | - | - |

Remark;

1. According to §15.31 (f)(2),
 - 300 m Result (dB μ V/m) = 3 m Result (dB μ V/m) - 40log (300/3) (dB μ V/m)
 - 30 m Result (dB μ V/m) = 3 m Result (dB μ V/m) - 40log (30/3) (dB μ V/m)
2. According to field strength table of general requirement in §15.209 (a), field strength limits below 1.705 MHz were calculated as below.
 - 9 kHz to 490 kHz: 20log (2 400 / F (kHz)) at 300 m (dB μ V/m)
 - 490 kHz to 1.705 MHz: 20log (24 000 / F (kHz)) at 30 m (dB μ V/m)
3. According to §15.209 (d), the measurements were tested by using Quasi peak detector except for the frequency bands 9-90 kHz, 110-490 kHz and above 1 GHz in these three bands on measurements employing an average detector.
4. The limit above was calculated based on table of §15.209 (a).
5. Radiated spurious emission measurement as below 30 MHz.
(Actual (dB μ A/m) at 3m = Reading (dB μ V) + AF (dB/m) + CL (dB))
6. Radiated spurious emission measurement as above 30 MHz.
(Actual (dB μ A/m) = Reading (dB μ V) + AF (dB/m) + CL (dB) + AMP (dB))
7. According to §15.31(o), emission levels are not report much lower than the limits by over 20 dB.

- Test plots

Test Condition: 2 W Operating mode with client device (1 % battery status of client device)

Ant. 1 (126.2 kHz ~ 129.2 kHz)

Below 30 MHz

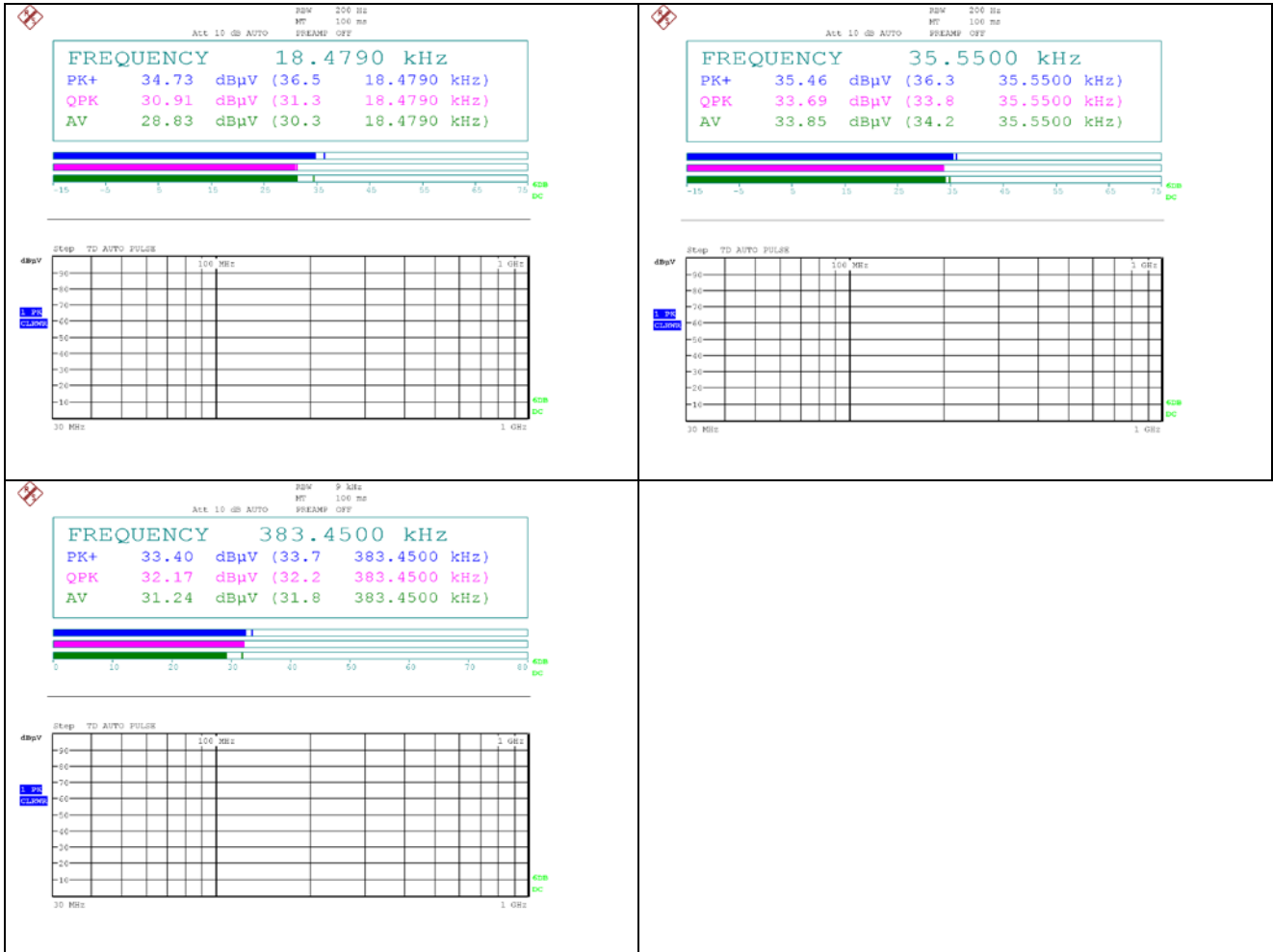

Above 30 MHz

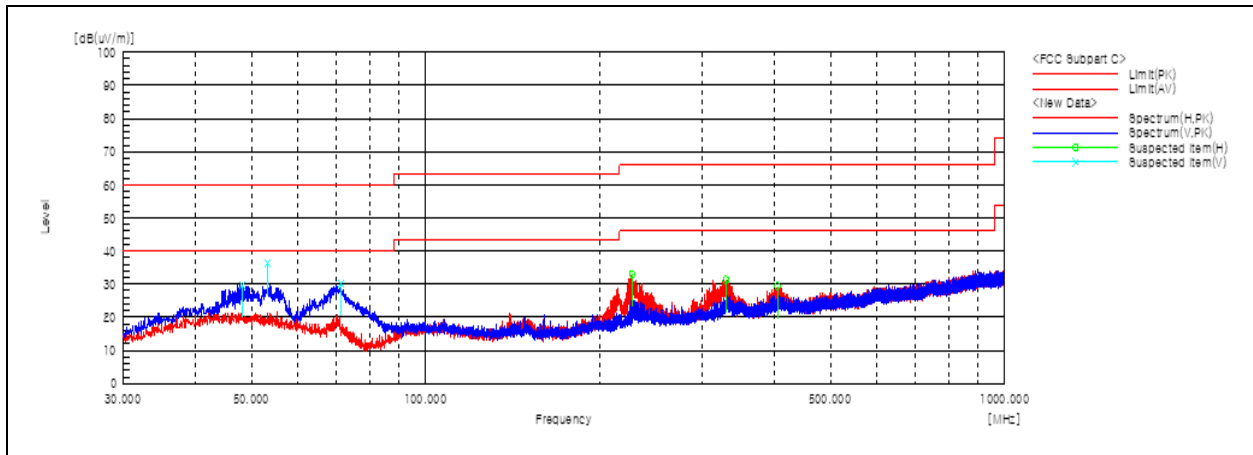

Remark;

- Traces shown in the plot were made by using a peak detector.

Test Condition: 4.5 W Operating mode with client device (1 % battery status of client device)

Ant. 1 (126.2 kHz ~ 129.2 kHz)

Below 30 MHz

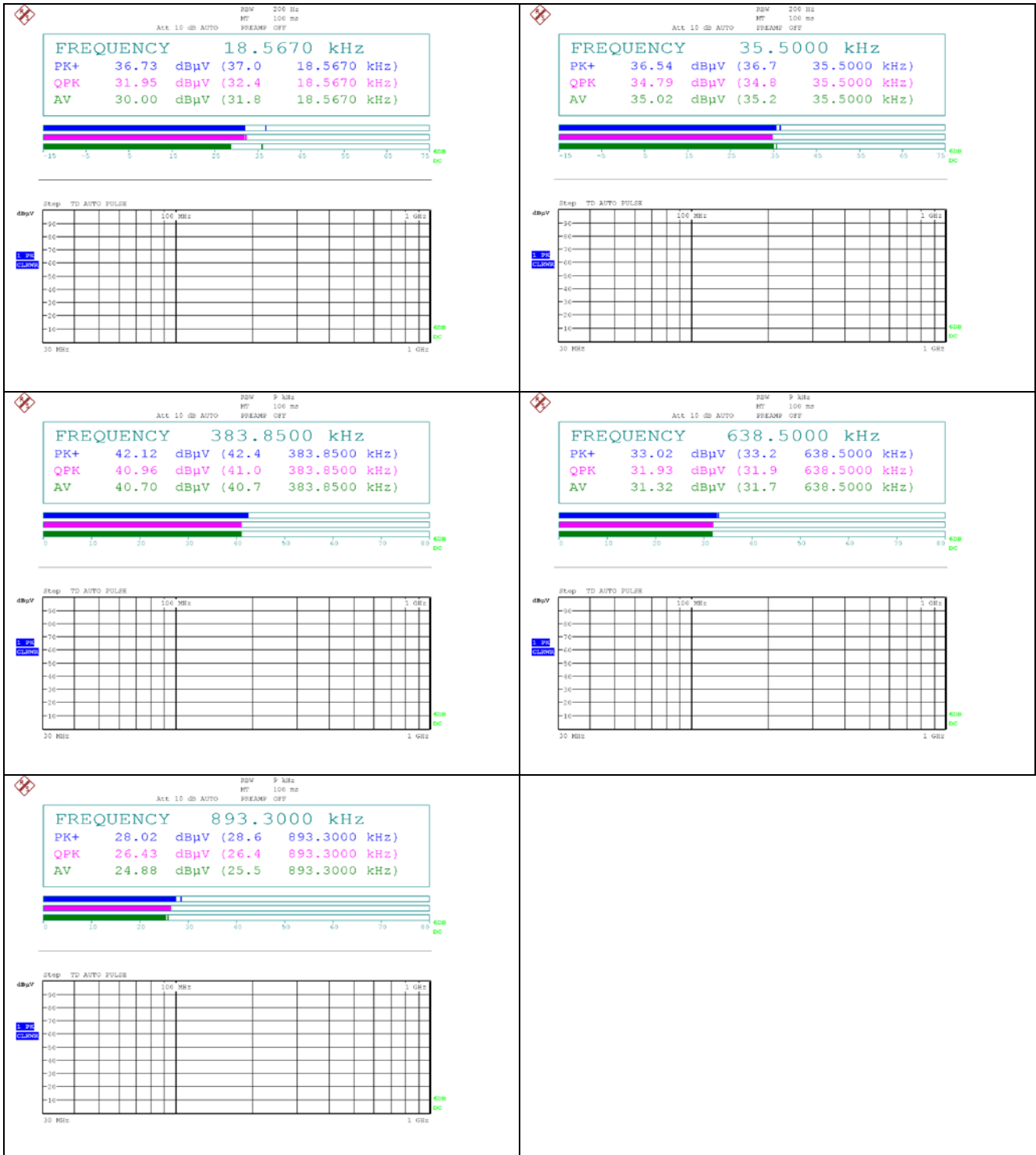

Above 30 MHz

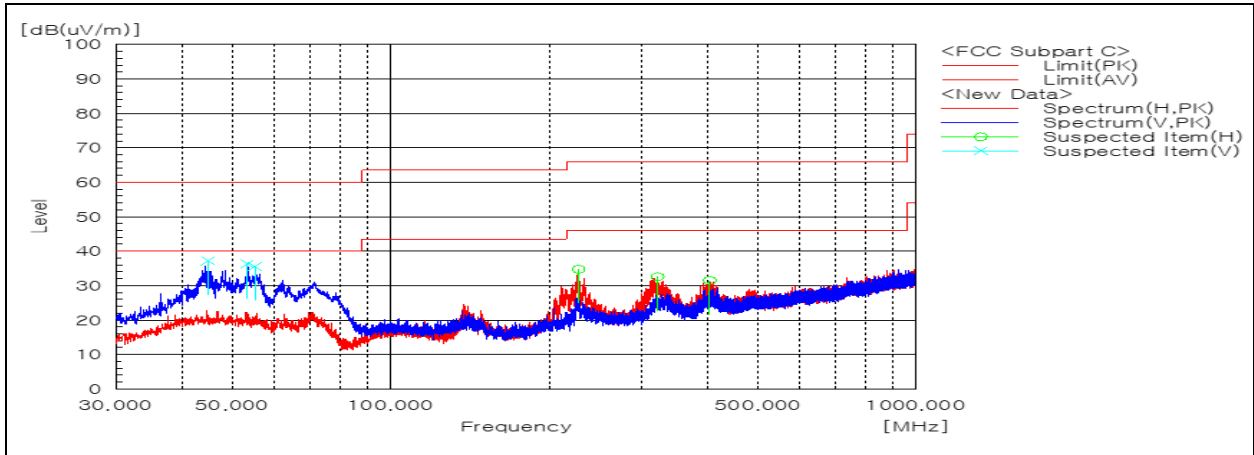

Remark;

- Traces shown in the plot were made by using a peak detector.

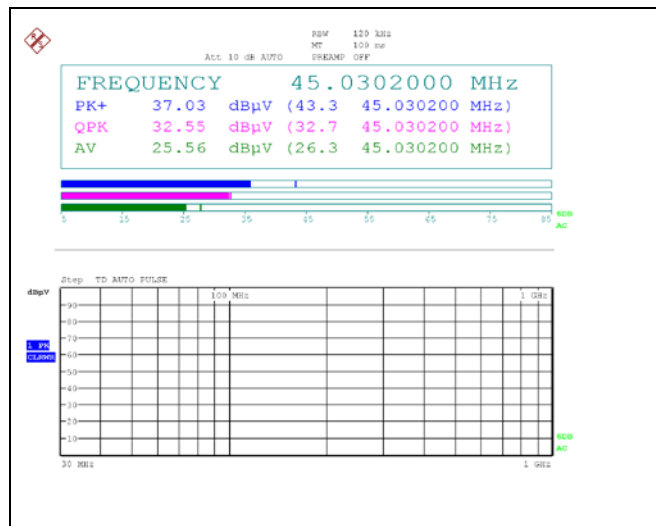

Test Condition: 7.5 W Operating mode with client device (1 % battery status of client device)

Ant. 1 (126.2 kHz ~ 129.2 kHz)

Below 30 MHz

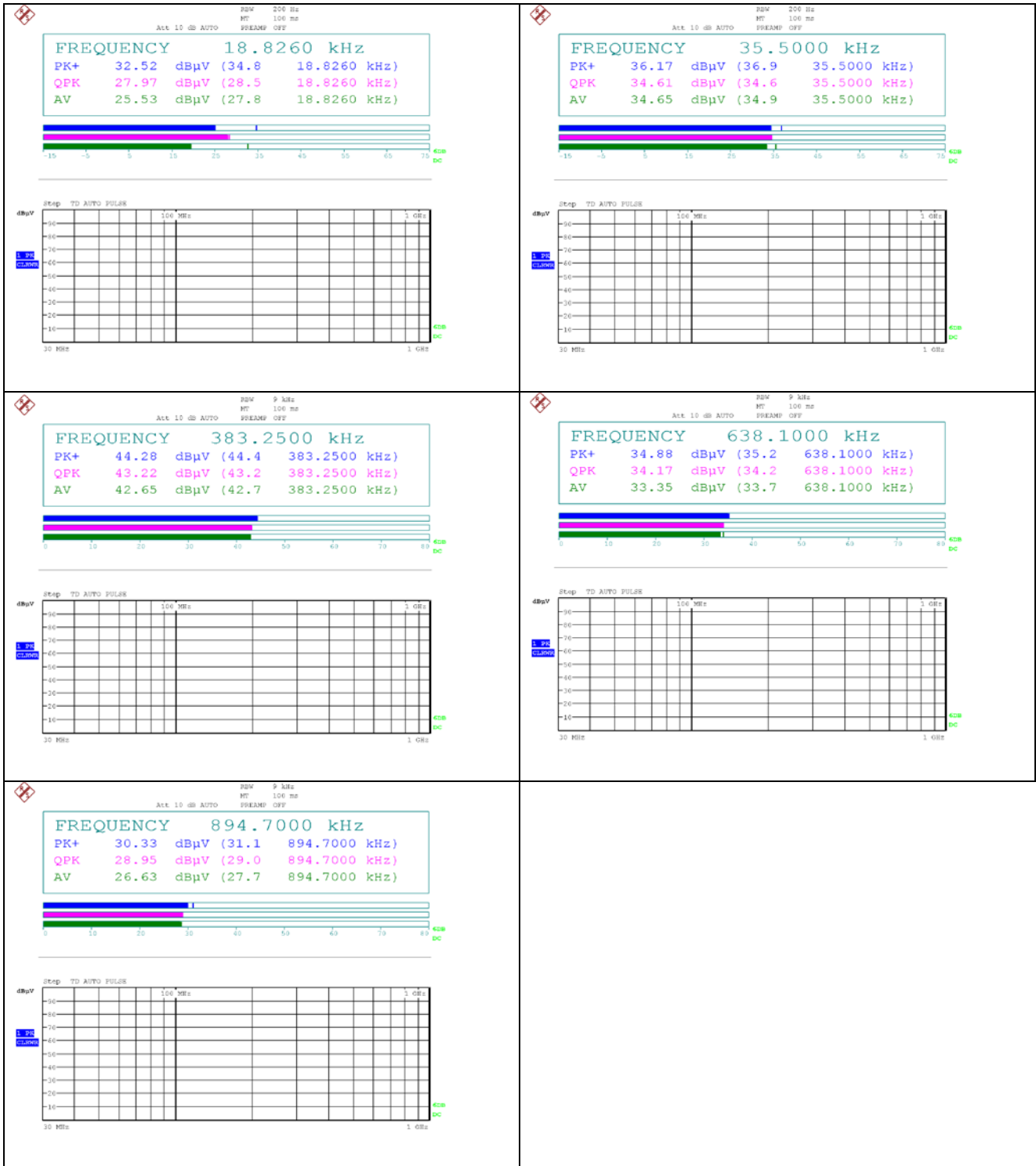

Above 30 MHz

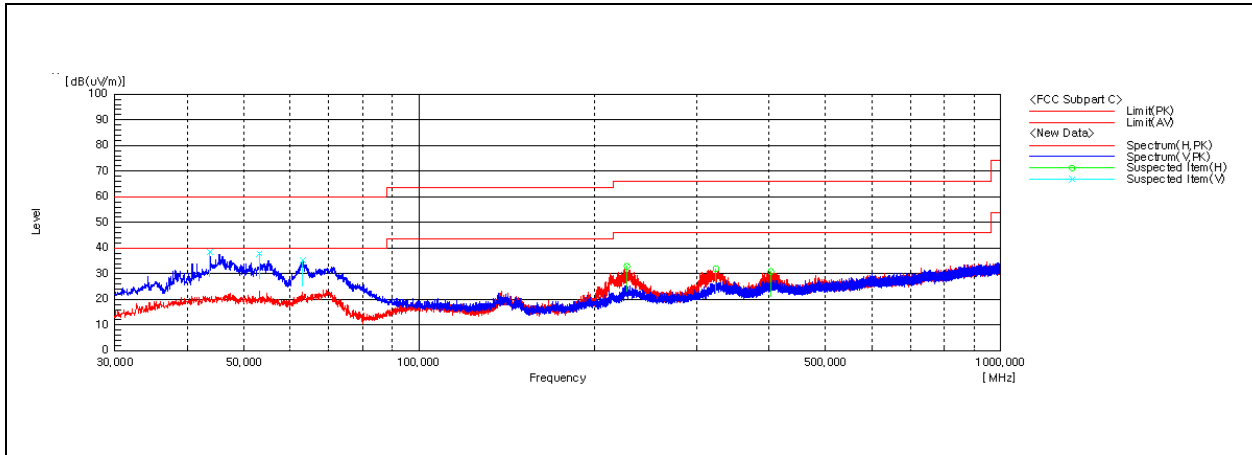

Remark;

- Traces shown in the plot were made by using a peak detector.

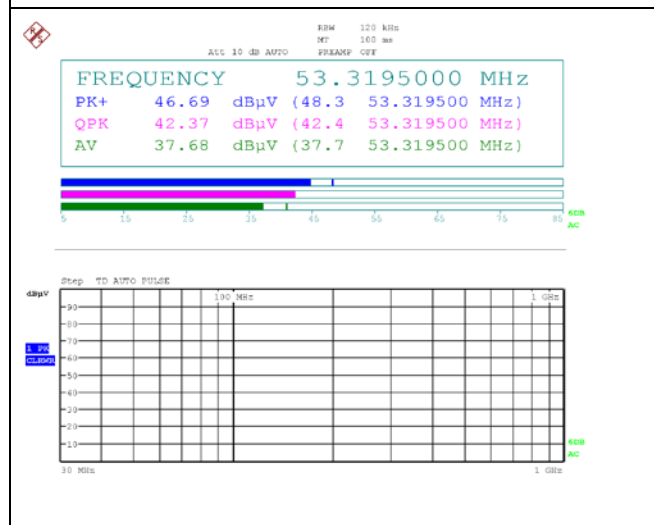
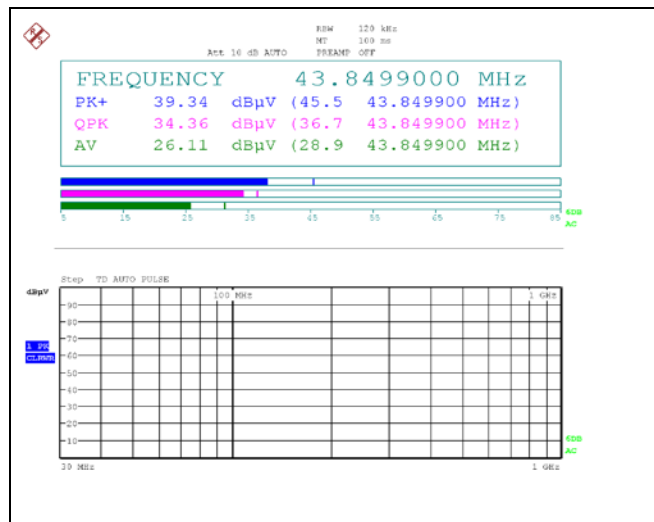

Test Condition: 9 W Operating mode with client device (1 % battery status of client device)

Ant. 1 (126.2 kHz ~ 129.2 kHz)

Below 30 MHz

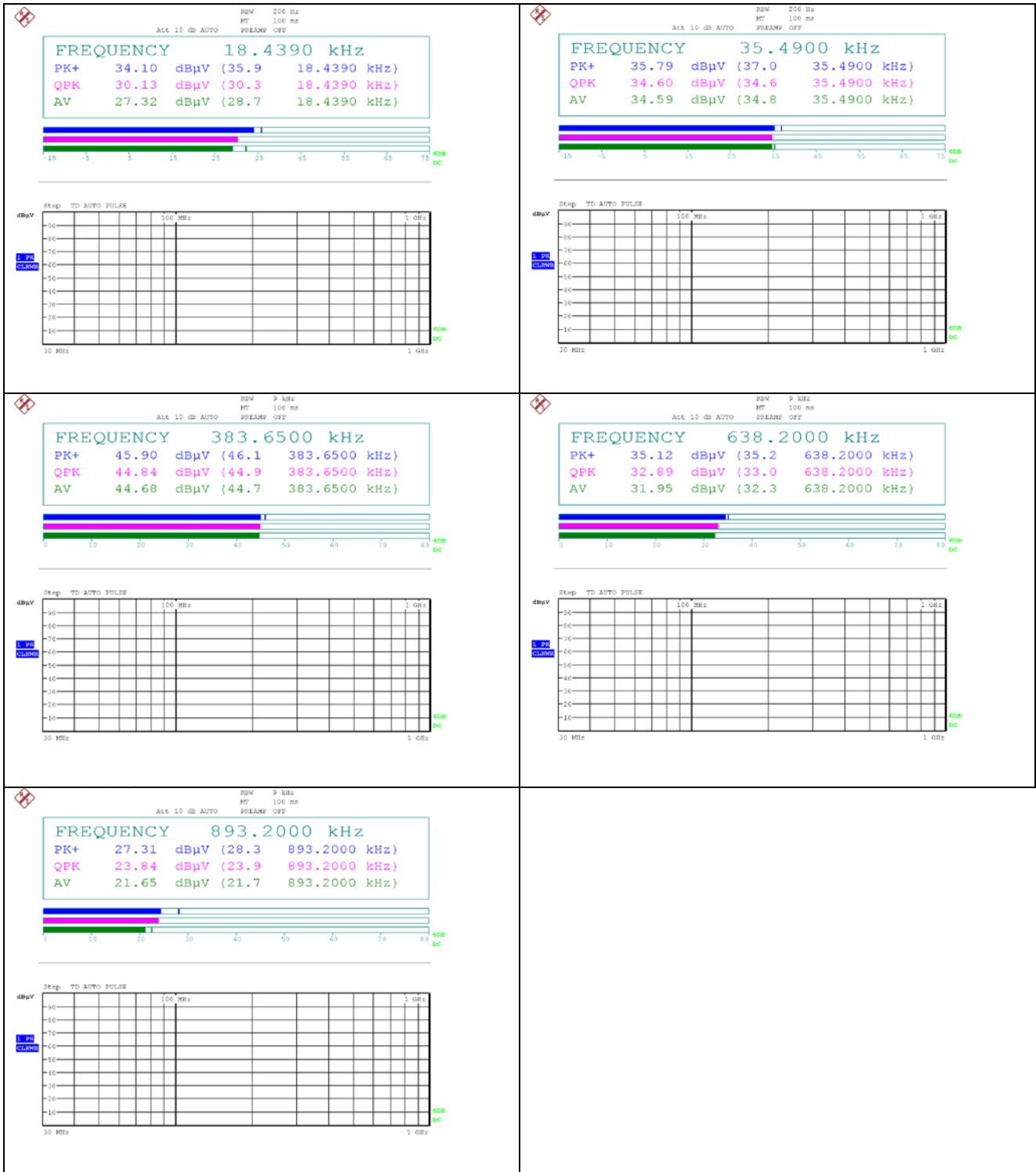

Above 30 MHz

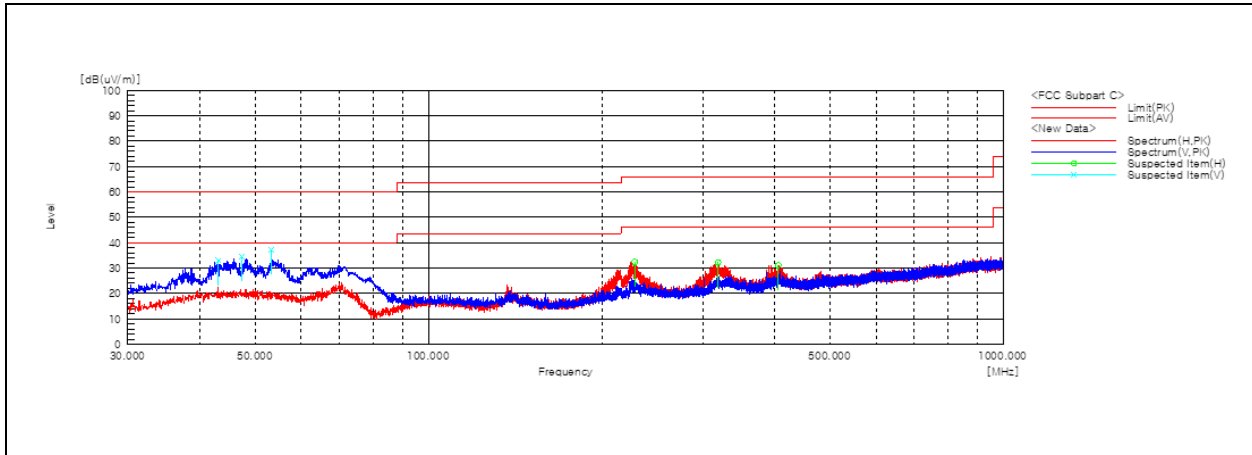

Remark;

- Traces shown in the plot were made by using a peak detector.

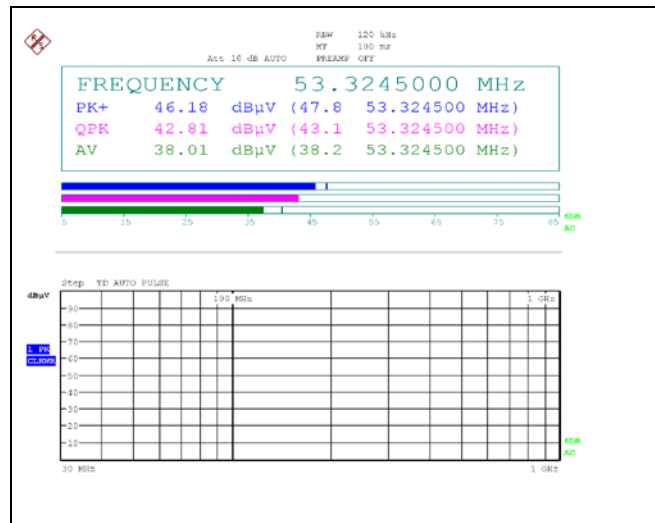

3. 20 dB Bandwidth

3.1. Test Setup

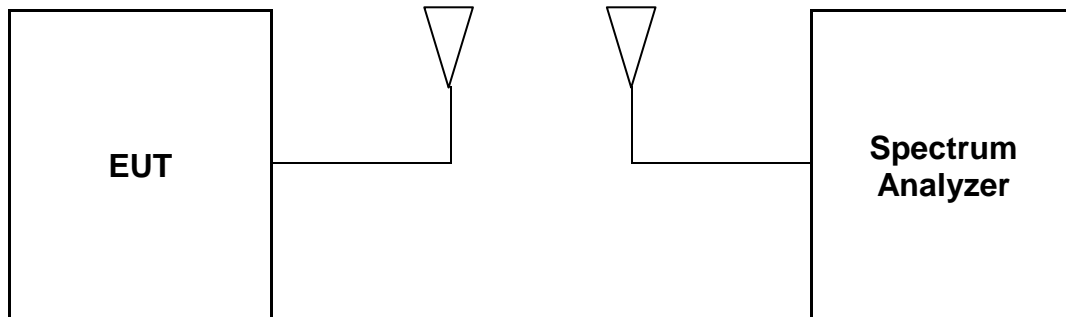

3.2. Limit

None; for reporting purposed only

3.3. Test Procedure

- a. Span = set to capture all products of the modulation process, including the emission skirts.
 RBW = 200 Hz, VBW = 200 Hz, Sweep = auto, Detector = peak, Trace = max hold.
- b. The marker-to-peak function to set the mark to the peak of the emission. Use the marker-delta function to measure 20 dB down one side of the emission. Reset the function, and move the marker to the other side of the emission, until it is (as close as possible to) even with the reference marker level. The marker-delta reading at this point is 20 dB bandwidth of the emission.

3.4. Test Result

Ambient temperature : (23 ± 1) °C
 Relative humidity : 47 % R.H.

| Test Condition | | EUT Status | 20 dB Bandwidth (kHz) | Limit |
|----------------|-----------------------|---|-----------------------|-------------------------|
| 2 W | 126.2 kHz ~ 129.2 kHz | With client device (1 % battery status of client device) | 0.509 | Reporting proposed only |
| 4.5 W | | | 0.509 | |
| 7.5 W | | | 0.509 | |
| 9 W | | | 0.509 | |

- Test plots

Test Condition: 2 W Operating mode with client device (1 % battery status of client device)

Ant. 1 (126.2 kHz ~ 129.2 kHz)

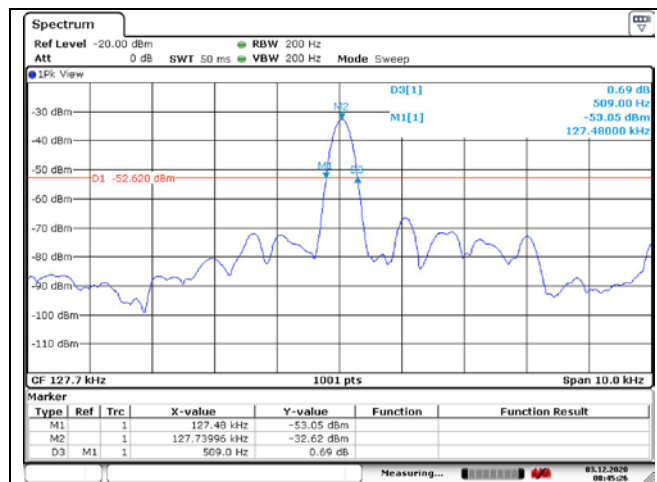

Test Condition: 4.5 W Operating mode with client device (1 % battery status of client device)

Ant. 1 (126.2 kHz ~ 129.2 kHz)

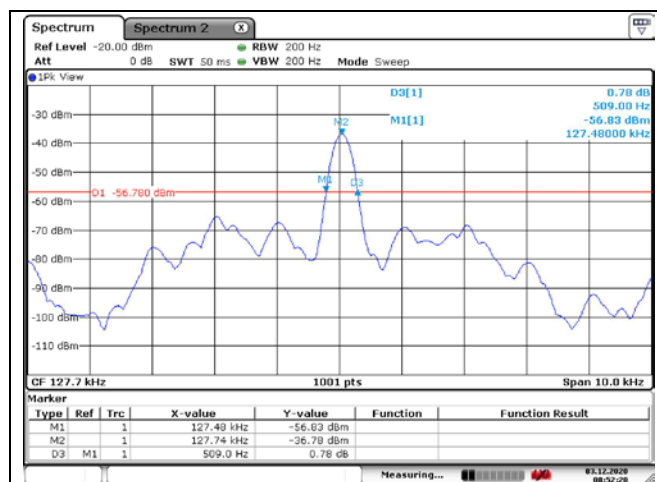

Test Condition: 7.5 W Operating mode with client device (1 % battery status of client device)

Ant. 1 (126.2 kHz ~ 129.2 kHz)

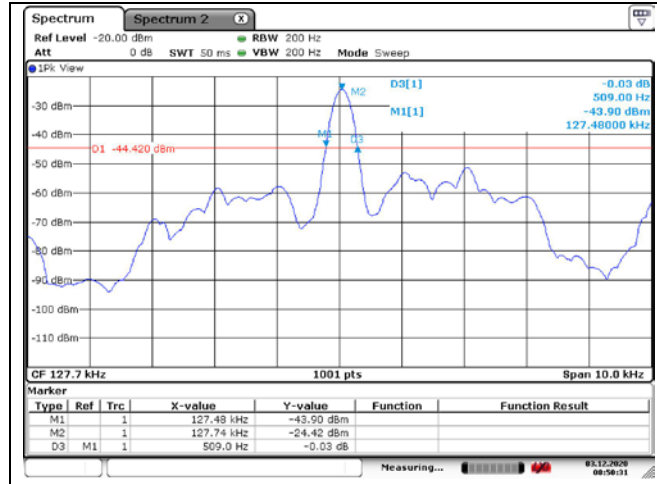

Test Condition: 9 W Operating mode with client device (1 % battery status of client device)

Ant. 1 (126.2 kHz ~ 129.2 kHz)

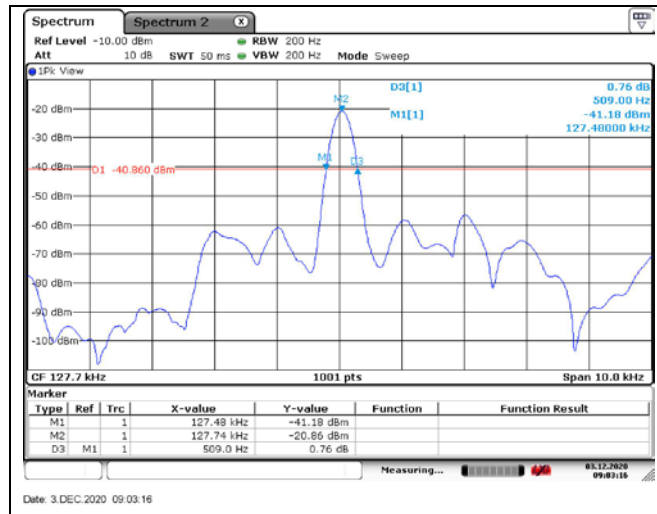

4. AC Power Line Conducted Emission

4.1. Test Setup

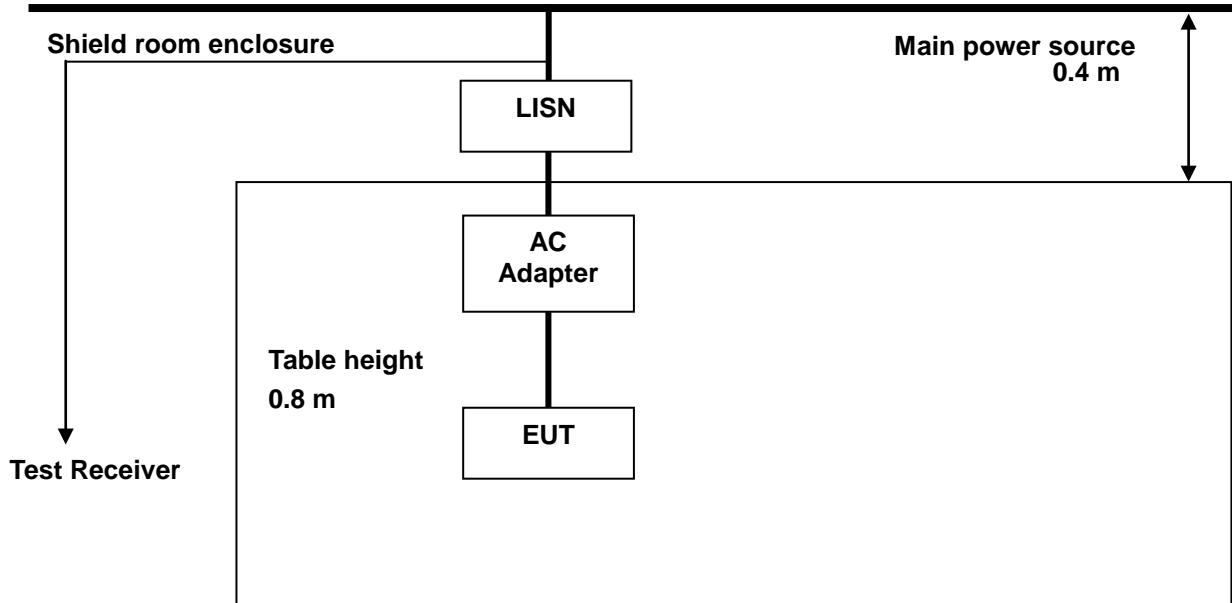

4.2. Limit

According to §15.207(a), for an intentional radiator that is designed to be connected to the public utility (AC) power line, the radio frequency voltage that is conducted back onto the AC power line on any frequency or frequencies, within the band 150 kHz to 30 MHz, shall not exceed the limits in the following table, as measured using a 50 μ H / 50 ohms line impedance stabilization network (LISN).

Compliance with the provision of this paragraph shall be based on the measurement of the radio frequency voltage between each power line and ground at the power terminal. The lower limit applies at the boundary between the frequency ranges.

| Frequency of emission (MHz) | Conducted limit (dB μ V) | |
|-----------------------------|------------------------------|-----------|
| | Quasi-peak | Average |
| 0.15-0.5 | 66 to 56* | 56 to 46* |
| 0.5-5 | 56 | 46 |
| 5-30 | 60 | 50 |

* Decreases with the logarithm of the frequency.

4.3. Test Procedures

AC conducted emissions from the EUT were measured according to the dictates of ANSI C63.10:2013

1. The test procedure is performed in a 6.5 m × 3.5 m × 3.5 m (L × W × H) shielded room. The EUT along with its peripherals were placed on a 1.0 m (W) × 1.5 m (L) and 0.8 m in height wooden table and the EUT was adjusted to maintain a 0.4 meter space from a vertical reference plane.
2. The EUT was connected to power mains through a line impedance stabilization network (LISN) which provides 50 ohm coupling impedance for measuring instrument and the chassis ground was bounded to the horizontal ground plane of shielded room.
3. All peripherals were connected to the second LISN and the chassis ground also bounded to the horizontal ground plane of shielded room.
4. The excess power cable between the EUT and the LISN was bundled. The power cables of peripherals were unbundled. All connecting cables of EUT and peripherals were moved to find the maximum emission.

4.4. Test Results

The following table shows the highest levels of conducted emissions on both phase of Hot and Neutral line.

Ambient temperature : (23 ± 1) °C
 Relative humidity : 47 % R.H.
 Frequency range : 0.15 MHz – 30 MHz
 Measured Bandwidth : 9 kHz

Test Condition: 2 W Operating mode with client device (1 % battery status of client device)

Ant. 1 (126.2 kHz ~ 129.2 kHz)

| FREQ. (MHz) | LEVEL (dB μ V) | | LINE | LIMIT (dB μ V) | | MARGIN (dB) | |
|----------------|--------------------|---------|------|--------------------|---------|-------------|---------|
| | Q-Peak | Average | | Q-Peak | Average | Q-Peak | Average |
| 0.15 | 33.20 | 24.60 | N | 66.00 | 56.00 | 32.80 | 31.40 |
| 0.20 | 30.00 | 13.10 | N | 63.82 | 53.82 | 33.82 | 40.72 |
| 0.70 | 24.10 | 17.30 | N | 56.00 | 46.00 | 31.90 | 28.70 |
| 2.79 | 19.30 | 11.70 | N | 56.00 | 46.00 | 36.70 | 34.30 |
| 11.56 | 29.40 | 20.10 | N | 60.00 | 50.00 | 30.60 | 29.90 |
| 23.14 | 19.60 | 10.00 | N | 60.00 | 50.00 | 40.40 | 40.00 |
| 0.16 | 28.90 | 24.30 | H | 65.46 | 55.46 | 36.56 | 31.16 |
| 0.21 | 25.10 | 9.90 | H | 63.21 | 53.21 | 38.11 | 43.31 |
| 0.70 | 17.00 | 9.40 | H | 56.00 | 46.00 | 39.00 | 36.60 |
| 2.04 | 17.80 | 13.50 | H | 56.00 | 46.00 | 38.20 | 32.50 |
| 11.53 | 23.30 | 16.60 | H | 60.00 | 50.00 | 36.70 | 33.40 |
| 21.59 | 15.00 | 8.10 | H | 60.00 | 50.00 | 45.00 | 41.90 |

Remark;

1. Line (H): Hot, Line (N): Neutral
2. Each charging mode with client device (1 %, 50 % and 99 % of battery) was tested.
As worst condition, charging mode with client device (1 %) is reported.
3. The limit for Class B device(s) from 150 kHz to 30 MHz are specified in section of the Title 47 CFR.
4. Traces shown in plot were made by using a peak detector and average detector.
5. Deviations to the Specifications: None.

- Test plots

Test mode: (Neutral)

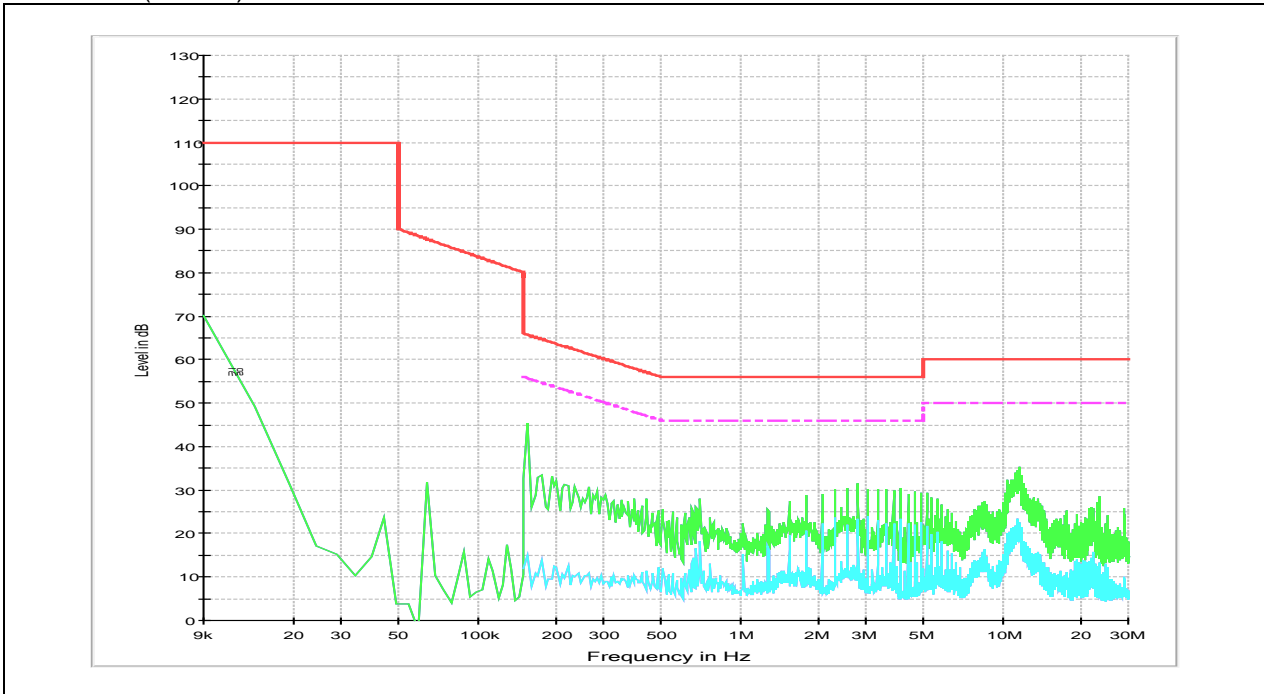

Test mode: (Hot)

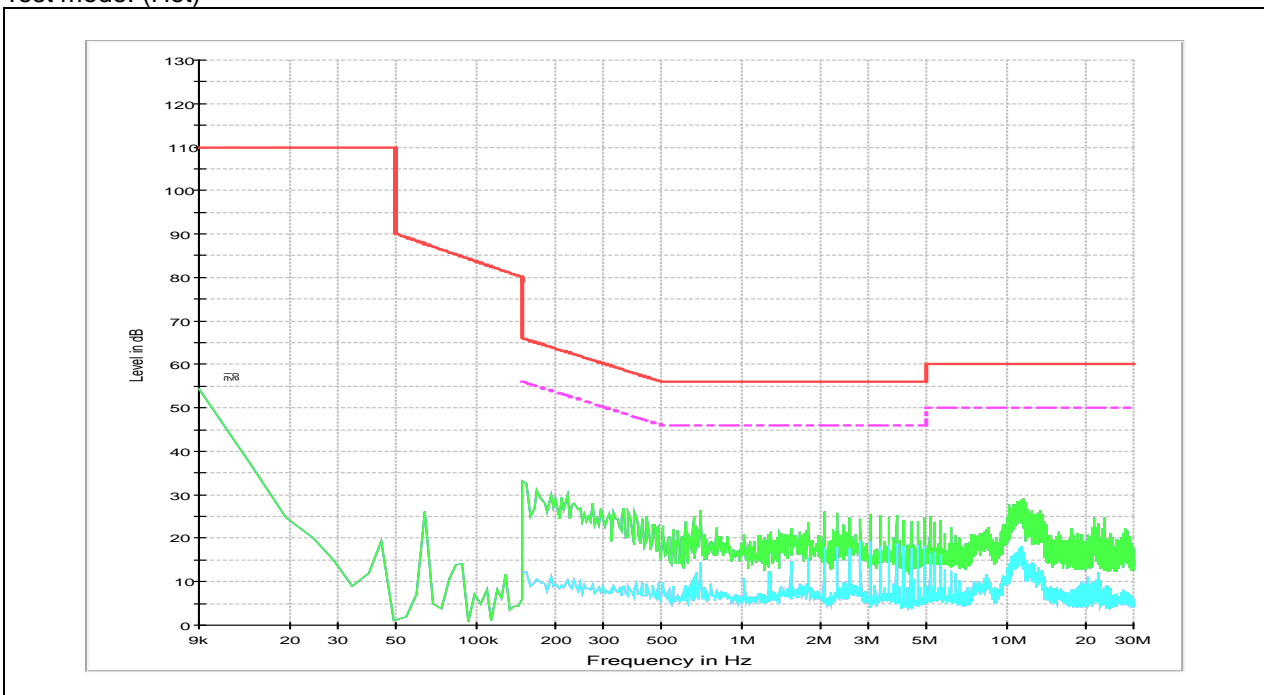

Test Condition: 4.5 W Operating mode with client device (1 % battery status of client device)

Ant. 1 (126.2 kHz ~ 129.2 kHz)

| FREQ. (MHz) | LEVEL (dB μ V) | | LINE | LIMIT (dB μ V) | | MARGIN (dB) | |
|----------------|--------------------|---------|------|--------------------|---------|-------------|---------|
| | Q-Peak | Average | | Q-Peak | Average | Q-Peak | Average |
| 0.17 | 41.20 | 23.80 | N | 64.96 | 54.96 | 23.76 | 31.16 |
| 0.41 | 30.90 | 13.50 | N | 57.65 | 47.65 | 26.75 | 34.15 |
| 0.91 | 19.80 | 9.50 | N | 56.00 | 46.00 | 36.20 | 36.50 |
| 2.18 | 33.90 | 29.00 | N | 56.00 | 46.00 | 22.10 | 17.00 |
| 11.50 | 39.10 | 30.50 | N | 60.00 | 50.00 | 20.90 | 19.50 |
| 14.61 | 33.30 | 24.10 | N | 60.00 | 50.00 | 26.70 | 25.90 |
| 0.17 | 43.10 | 22.60 | H | 64.96 | 54.96 | 21.86 | 32.36 |
| 0.46 | 30.40 | 12.70 | H | 56.69 | 46.69 | 26.29 | 33.99 |
| 1.16 | 20.40 | 10.20 | H | 56.00 | 46.00 | 35.60 | 35.80 |
| 2.30 | 25.40 | 20.60 | H | 56.00 | 46.00 | 30.60 | 25.40 |
| 11.39 | 33.50 | 26.40 | H | 60.00 | 50.00 | 26.50 | 23.60 |
| 13.92 | 31.50 | 21.20 | H | 60.00 | 50.00 | 28.50 | 28.80 |

Remark;

- Line (H): Hot, Line (N): Neutral
- Each charging mode with client device (1 %, 50 % and 99 % of battery) was tested. As worst condition, charging mode with client device (1 %) is reported.
- The limit for Class B device(s) from 150 kHz to 30 MHz are specified in section of the Title 47 CFR.
- Traces shown in plot were made by using a peak detector and average detector.
- Deviations to the Specifications: None.

- Test plots

Test mode: (Neutral)

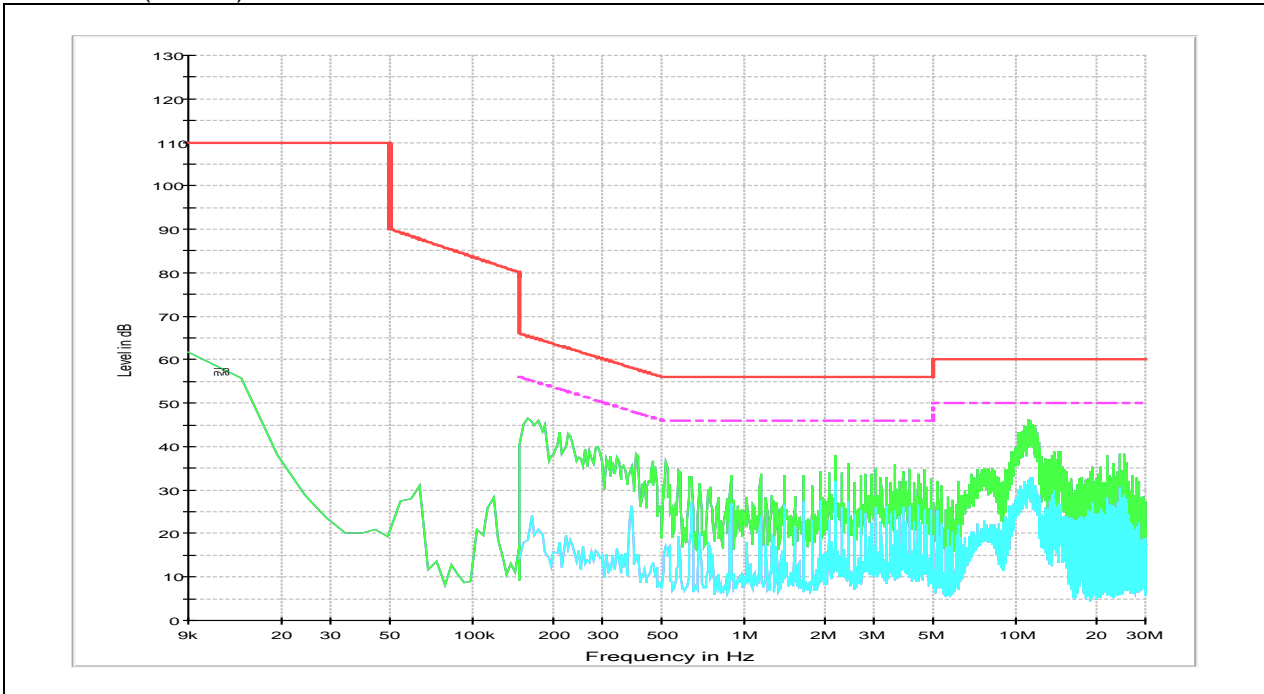

Test mode: (Hot)

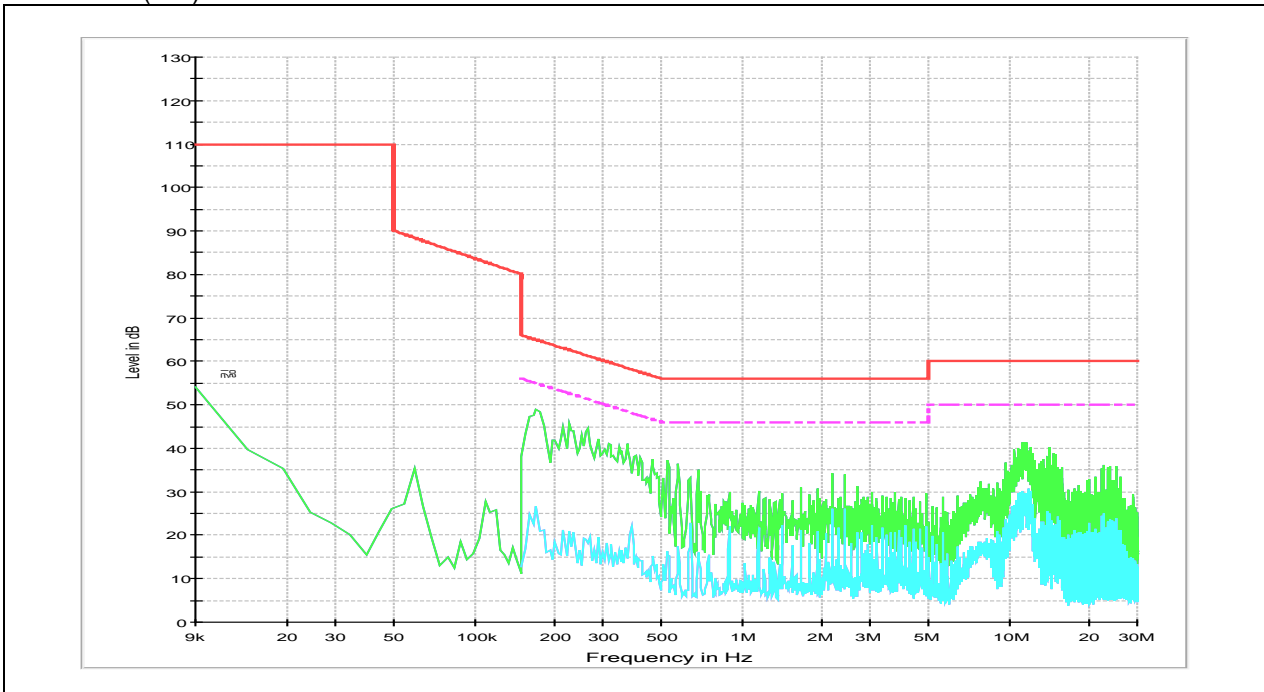

Test Condition: 7.5 W Operating mode with client device (1 % battery status of client device)

Ant. 1 (126.2 kHz ~ 129.2 kHz)

| FREQ. (MHz) | LEVEL (dB μ V) | | LINE | LIMIT (dB μ V) | | MARGIN (dB) | |
|----------------|--------------------|---------|------|--------------------|---------|-------------|---------|
| | Q-Peak | Average | | Q-Peak | Average | Q-Peak | Average |
| 0.16 | 39.90 | 16.20 | N | 65.46 | 55.46 | 25.56 | 39.26 |
| 0.34 | 31.20 | 13.70 | N | 59.20 | 49.20 | 28.00 | 35.50 |
| 0.89 | 19.60 | 10.40 | N | 56.00 | 46.00 | 36.40 | 35.60 |
| 2.44 | 23.90 | 18.30 | N | 56.00 | 46.00 | 32.10 | 27.70 |
| 8.48 | 29.50 | 19.10 | N | 60.00 | 50.00 | 30.50 | 30.90 |
| 11.68 | 39.30 | 32.40 | N | 60.00 | 50.00 | 20.70 | 17.60 |
| 0.16 | 40.80 | 23.50 | H | 65.46 | 55.46 | 24.66 | 31.96 |
| 0.22 | 35.30 | 17.90 | H | 62.82 | 52.82 | 27.52 | 34.92 |
| 0.64 | 25.60 | 21.50 | H | 56.00 | 46.00 | 30.40 | 24.50 |
| 2.43 | 33.70 | 29.00 | H | 56.00 | 46.00 | 22.30 | 17.00 |
| 11.60 | 34.10 | 26.70 | H | 60.00 | 50.00 | 25.90 | 23.30 |
| 14.83 | 28.70 | 15.80 | H | 60.00 | 50.00 | 31.30 | 34.20 |

Remark;

1. Line (H): Hot, Line (N): Neutral
2. Each charging mode with client device (1 %, 50 % and 99 % of battery) was tested.
As worst condition, charging mode with client device (1 %) is reported.
3. The limit for Class B device(s) from 150 kHz to 30 MHz are specified in section of the Title 47 CFR.
4. Traces shown in plot were made by using a peak detector and average detector.
5. Deviations to the Specifications: None.

- Test plots

Test mode: (Neutral)

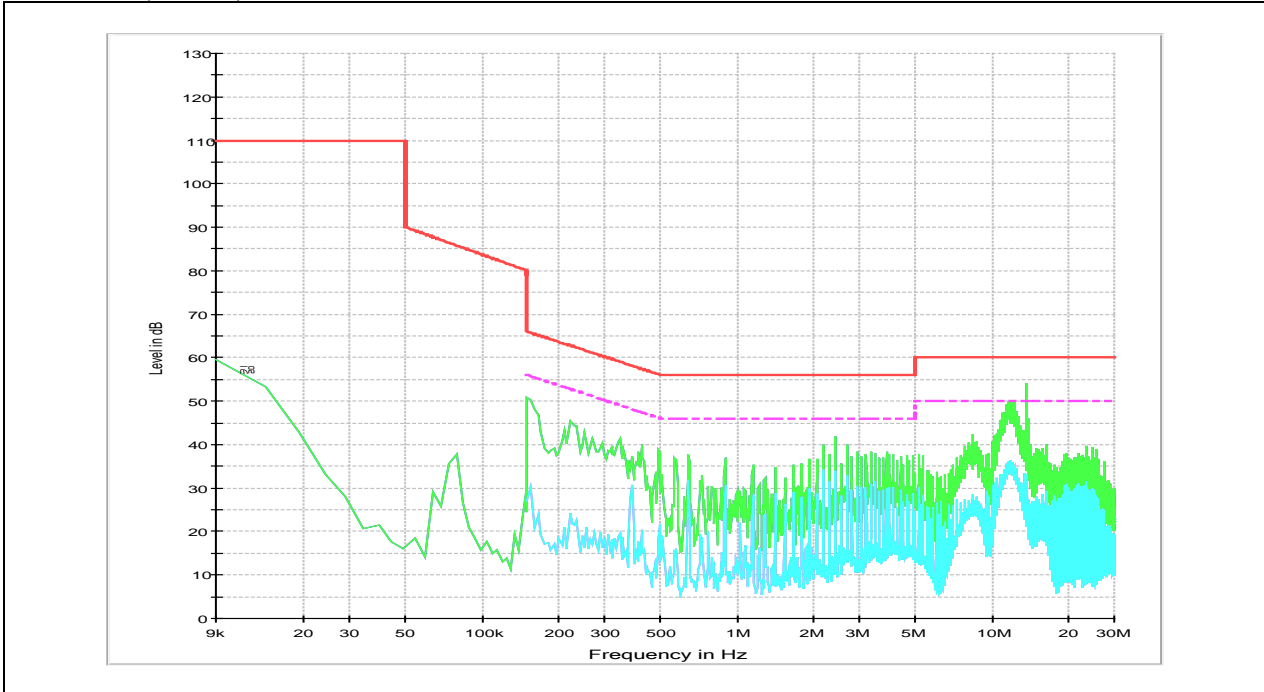

Test mode: (Hot)

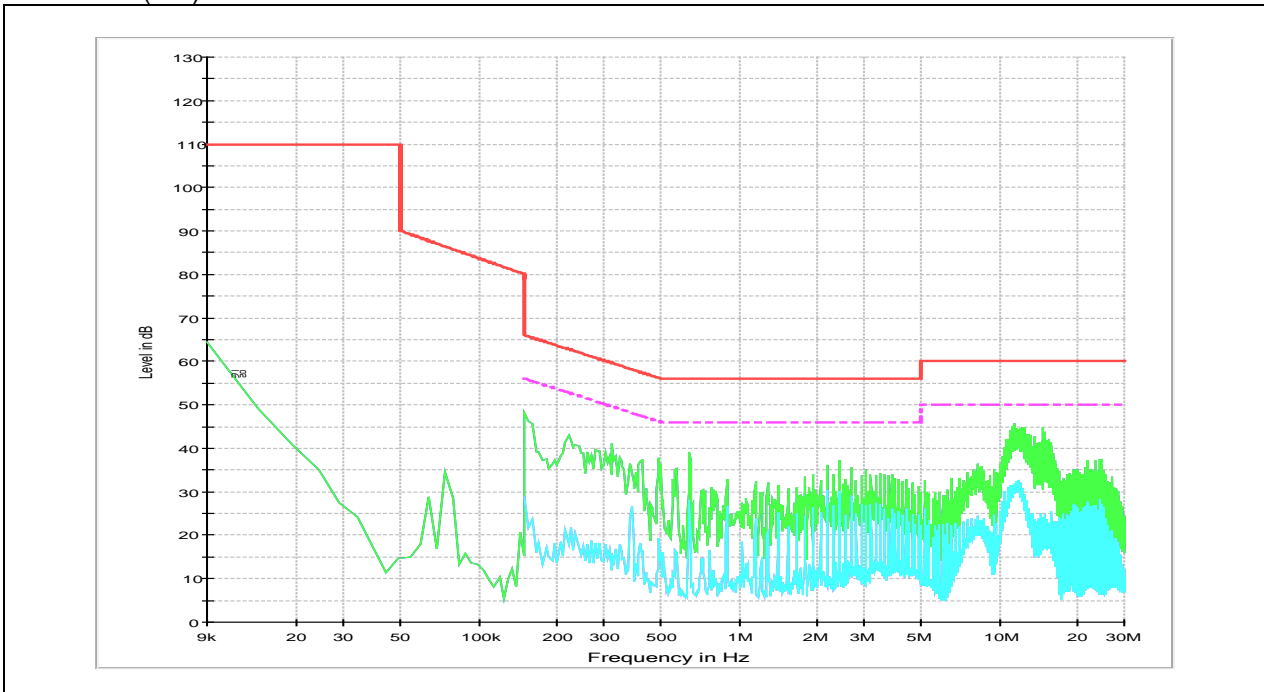

Test Condition: 9 W Operating mode with client device (1 % battery status of client device)

Ant. 1 (126.2 kHz ~ 129.2 kHz)

| FREQ. (MHz) | LEVEL (dB μ V) | | LINE | LIMIT (dB μ V) | | MARGIN (dB) | |
|----------------|--------------------|---------|------|--------------------|---------|-------------|---------|
| | Q-Peak | Average | | Q-Peak | Average | Q-Peak | Average |
| 0.16 | 48.00 | 28.50 | N | 65.46 | 55.46 | 17.46 | 26.96 |
| 0.23 | 42.50 | 23.40 | N | 62.45 | 52.45 | 19.95 | 29.05 |
| 1.41 | 40.40 | 34.00 | N | 56.00 | 46.00 | 15.60 | 12.00 |
| 3.32 | 40.00 | 35.00 | N | 56.00 | 46.00 | 16.00 | 11.00 |
| 8.90 | 33.50 | 24.30 | N | 60.00 | 50.00 | 26.50 | 25.70 |
| 12.01 | 43.90 | 35.00 | N | 60.00 | 50.00 | 16.10 | 15.00 |
| 0.16 | 44.40 | 25.40 | H | 65.46 | 55.46 | 21.06 | 30.06 |
| 0.22 | 37.30 | 18.30 | H | 62.82 | 52.82 | 25.52 | 34.52 |
| 0.65 | 30.30 | 19.80 | H | 56.00 | 46.00 | 25.70 | 26.20 |
| 1.15 | 29.50 | 25.00 | H | 56.00 | 46.00 | 26.50 | 21.00 |
| 8.43 | 32.50 | 25.50 | H | 60.00 | 50.00 | 27.50 | 24.50 |
| 11.29 | 38.20 | 31.10 | H | 60.00 | 50.00 | 21.80 | 18.90 |

Remark;

1. Line (H): Hot, Line (N): Neutral
2. Each charging mode with client device (1 %, 50 % and 99 % of battery) was tested.
As worst condition, charging mode with client device (1 %) is reported.
3. The limit for Class B device(s) from 150 kHz to 30 MHz are specified in section of the Title 47 CFR.
4. Traces shown in plot were made by using a peak detector and average detector.
5. Deviations to the Specifications: None.

- Test plots

Test mode: (Neutral)

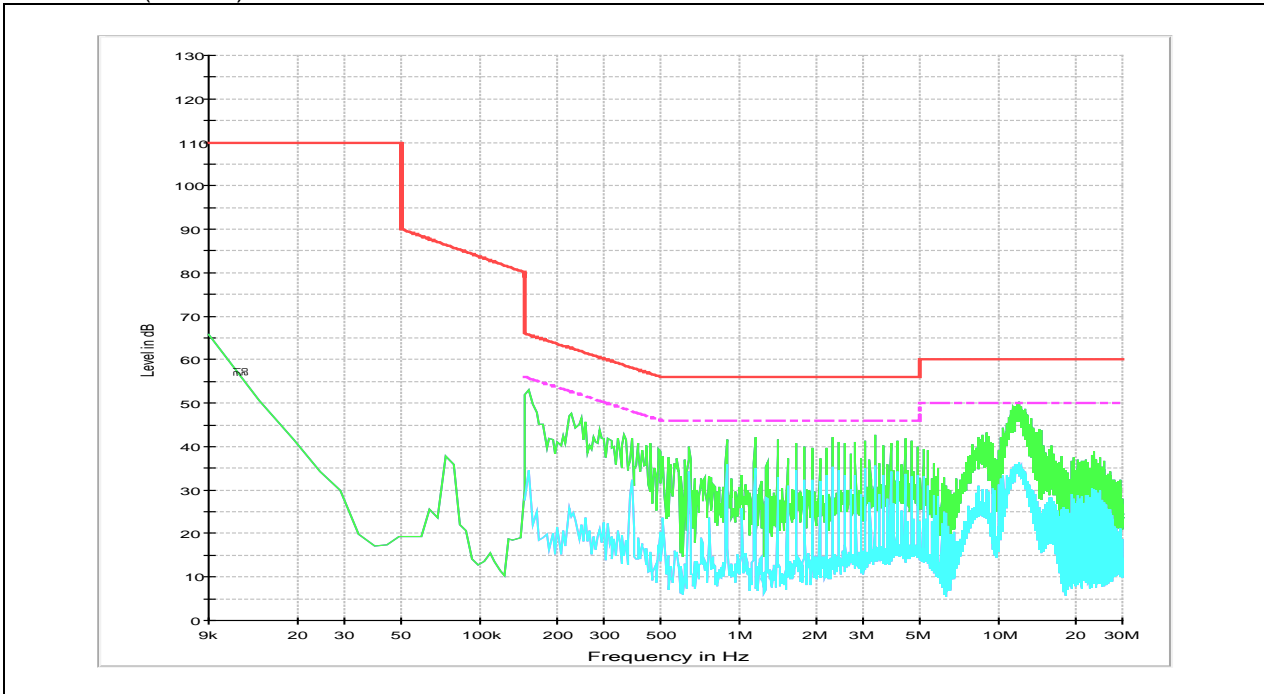

Test mode: (Hot)

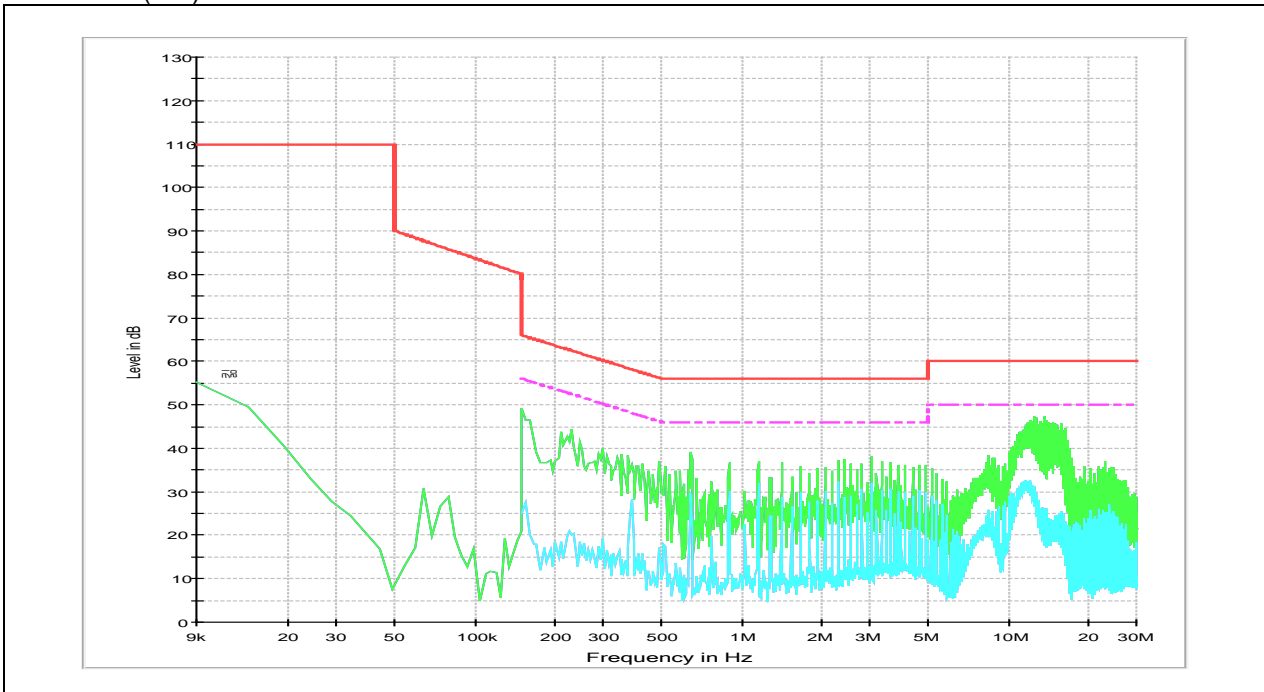

- End of the Test Report -