

# TEST REPORT

OF

FCC Part 15 Subpart C §15.209

FCC ID : A3LEPNG930

Equipment Under Test : WIRELESS CHARGER  
Model Name : EP-NG930  
Applicant : Samsung Electronics Co., Ltd.  
Manufacturer : Samsung Electronics Co., Ltd.  
Date of Test(s) : 2016.02.03 ~ 2016.02.15  
Date of Issue : 2016.02.15

In the configuration tested, the EUT complied with the standards specified above.

Tested By:



Youngmin Park

Date:

2016.02.15

Approved By:



Logan Lee

Date:

2016.02.15

*The results shown in this test report refer only to the sample(s) tested unless otherwise stated. This test report cannot be reproduced, except in full, without prior written permission of the Company.*

---

# INDEX

<u>TABLE OF CONTENTS</u>	Page
1. General Information -----	3
2. Field Strength of Fundamental and Spurious Emission -----	7
3. 20 dB Bandwidth -----	19
4. Transmitter AC Power Line Conducted Emission -----	22

---

*The results shown in this test report refer only to the sample(s) tested unless otherwise stated. This test report cannot be reproduced, except in full, without prior written permission of the Company.*

## 1. General Information

### 1.1. Testing laboratory

SGS Korea Co., Ltd. (Gunpo Laboratory)

- Wireless Div. 2FL, 10-2, LS-ro 182beon-gil, Gunpo-si, Gyeonggi-do, Korea, 15807

All SGS services are rendered in accordance with the applicable SGS conditions of service available on request and accessible at <http://www.sgs.com/en/Terms-and-Conditions.aspx>.

Phone No. : +82 31 688 0901

Fax No. : +82 31 688 0921

### 1.2. Details of applicant

Applicant : Samsung Electronics Co., Ltd.

Address : 129, Samsung-ro, Yeongtong-gu, Suwon-si, Gyeonggi-do, 16677, Republic of Korea

Contact Person : Kim, Kyung-Won

Phone No. : +82 31 301 0274

### 1.3. Description of EUT

<b>Kind of Product</b>	WIRELESS CHARGER
<b>Model Name</b>	EP-NG930
<b>Power Supply</b>	DC 5 V, DC 9 V (Used AC 100 V ~ 240 V adaptor)
<b>Frequency Range</b>	110 kHz ~ 148 kHz
<b>Antenna Type</b>	Inductive loop coil antenna

### 1.4. Declarations by the manufacturer

- Operation temperature: -20 °C ~ 70 °C

- The EUT has 2 loop coil antennas, and only one antenna can transmit at once.

*The results shown in this test report refer only to the sample(s) tested unless otherwise stated. This test report cannot be reproduced, except in full, without prior written permission of the Company.*

### 1.5. Test Equipment List

Equipment	Manufacturer	Model	S/N	Cal. Date	Cal. Interval	Cal. Due
Spectrum Analyzer	R&S	FSV30	100768	Mar. 24, 2015	Annual	Mar. 24, 2016
Signal Generator	R&S	SMBV100A	255834	Jun. 22, 2015	Annual	Jun. 22, 2016
Signal Generator	Agilent	8648D	3847M00534	Mar. 23, 2015	Annual	Mar. 23, 2016
DC Power Supply	Agilent	U8002A	MY50060028	Mar. 23, 2015	Annual	Mar. 23, 2016
Test Receiver	R&S	ESU26	100109	Mar. 03, 2015	Annual	Mar. 03, 2016
Test Receiver	R&S	ESCI 7	100911	Dec. 22, 2015	Annual	Dec. 22, 2016
Loop Antenna	R&S	HFH2-Z2	100118	Jun. 04, 2015	Biennial	Jun. 04, 2017
Two-Line V-Network	R&S	ENV216	100190	Dec. 21, 2015	Annual	Dec. 21, 2016
Turn Table	INN-CO	DS 1200 S	N/A	N.C.R.	N/A	N.C.R.
Anechoic Chamber	SY Corporation	L x W x H (9.6 m x 6.4 m x 6.6 m)	N/A	N.C.R.	N/A	N.C.R.
Shield Room	SY Corporation	L x W x H (6.5 m x 3.5 m x 3.5 m)	N/A	N.C.R.	N/A	N.C.R.

### 1.6. Sample calculation

Where relevant, the following sample calculation is provided:

Field strength level (dB $\mu$ V/m) = Measured level (dB $\mu$ V) + Antenna factor (dB) + Cable loss (dB)

*The results shown in this test report refer only to the sample(s) tested unless otherwise stated. This test report cannot be reproduced, except in full, without prior written permission of the Company.*

### 1.7. Worst case of test configurations

In order to check all kinds of possible configurations, EUT was evaluated with appropriate client and under each charging condition as below table.

EUT configuration	Type	Description
Charging Mode with client device (Model : SM-G930V, FCC ID : A3LSMG930US)	DC 5.0 V	Less than 1 % of battery
		Less than 50 % of battery
		100 % full charging of battery
	DC 9.0 V	Less than 1 % of battery
		Less than 50 % of battery
		100 % full charging of battery

Operating configurations :

Client device (SM- G930V)

- While the client device was in airplane mode (Trace#1 "M1")
- While the client device was connected to an active data connection (Trace#2 "M2")  
The device was tested under all modes and bands like 2G and 3G.  
In the result, **PCS GSM / GPRS1900 / 1 TX** was found in **Middle channel**.
- While the wireless charger is charging with the client device turned off. (Trace#3 "M3")

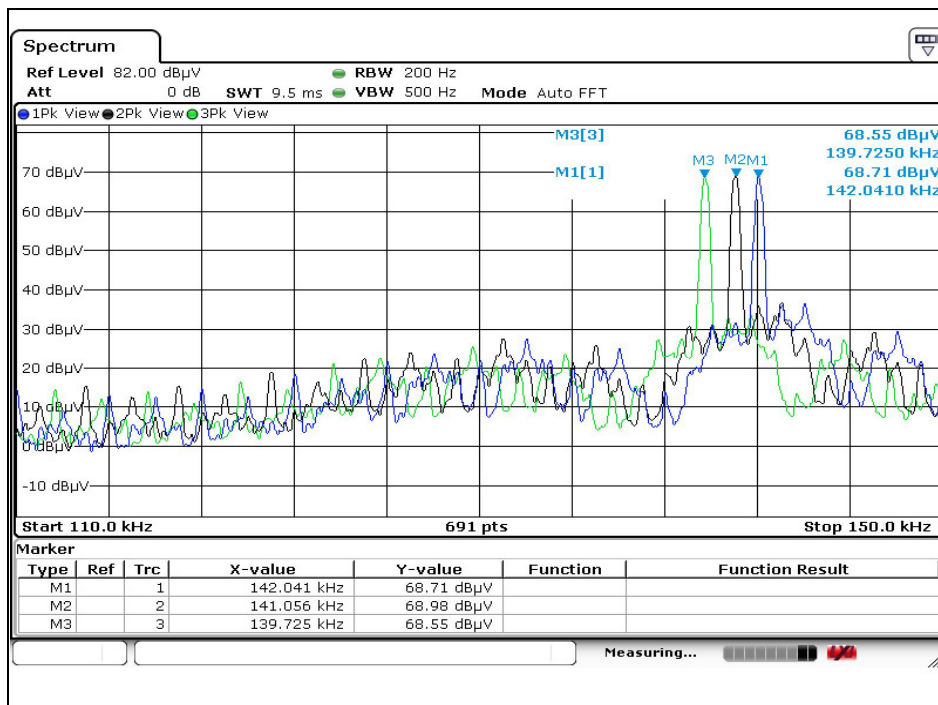

Plot – fundamental emission comparison

- The level of Trace#2 was more than Trace#1 and 3 so Trace#2 was selected.
- Trace#2 as **PCS GSM / GPRS1900 / 1 TX** which was found in **Middle channel** should be tested with the client device as a worst case.

The results shown in this test report refer only to the sample(s) tested unless otherwise stated. This test report cannot be reproduced, except in full, without prior written permission of the Company.

### 1.8. Summary of Test Results

The EUT has been tested according to the following specifications:

APPLIED STANDARD: FCC Part 15 Subpart C §15.209		
Section in FCC Part 15 Subpart C	Test Item	Result
15.209 15.209(a)	Radiated emission, Spurious Emission and Field Strength of Fundamental	Complied
2.1049	20 dB Bandwidth	Complied
15.207	Transmitter AC Power Line Conducted Emission	Complied

### 1.9. Test Report Revision

Revision	Report number	Date of Issue	Description
0	F690501/RF-RTL009493	2016.02.15	Initial

*The results shown in this test report refer only to the sample(s) tested unless otherwise stated. This test report cannot be reproduced, except in full, without prior written permission of the Company.*

## 2. Field Strength of Fundamental and Spurious Emission

### 2.1. Test Setup

The diagram below shows the test setup that is utilized to make the measurements for emission from 9 kHz to 30 MHz Emissions.

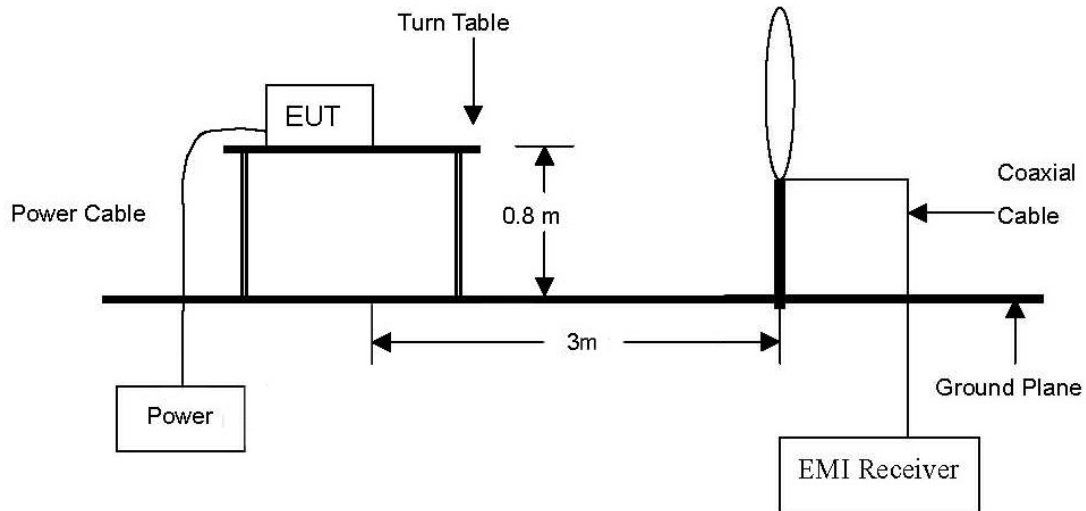

### 2.2. Limit

#### 2.2.1. Radiated emission limits, general requirements

According to §15.209 (a), Except as provided elsewhere in this Subpart, the emissions from an intentional radiator shall not exceed the field strength levels specified in the following table:

Frequency (MHz)	Field Strength (microvolts/meter)	Measurement Distance (meter)
0.009 - 0.490	2 400/F(kHz)	300
0.490 - 1.705	24 000/F(kHz)	30
1.705 - 30.0	30	30
30 - 88	100**	3
88 - 216	150**	3
216 - 960	200**	3
Above 960	500	3

\*\* Except as provided in paragraph (g), fundamental emissions from intentional radiators operating under this Section shall not be located in the frequency bands 54-72 MHz, 76-88 MHz, 174-216 MHz or 470-806 MHz. However, operation within these frequency bands is permitted under other sections of this Part, e.g., Sections §15.231 and §15.241

*The results shown in this test report refer only to the sample(s) tested unless otherwise stated. This test report cannot be reproduced, except in full, without prior written permission of the Company.*

## 2.3. Test Procedures

Radiated emissions from the EUT were measured according to the dictates of ANSI C63.10:2009

### 2.3.1. Test Procedures for emission from 9 kHz to 30 MHz

- a. The EUT was placed on the top of a rotating table 0.8 meters above the ground at a 3 meter anechoic chamber test site. The table was rotated 360 degrees to determine the position of the highest radiation.
- b. Then antenna is a loop antenna is fixed at one meter above the ground to determine the maximum value of the field strength. Both parallel and perpendicular of the antenna are set to make the measurement.
- c. For each suspected emission, the EUT was arranged to its worst case and then the table was turned from 0 degrees to 360 degrees to find the maximum reading.
- d. The test-receiver system was set to Peak Detect Function and Specified Bandwidth with Maximum Hold Mode.

---

*The results shown in this test report refer only to the sample(s) tested unless otherwise stated. This test report cannot be reproduced, except in full, without prior written permission of the Company.*

## 2.4. Field Strength of Fundamental Test Result

Ambient temperature : (24 ± 1) °C  
 Relative humidity : 47 % R.H.

The following table shows the highest levels of radiated emissions on both polarizations of horizontal and vertical. The field strength of spurious emission was measured in one orthogonal EUT position (x-axis).

### Test condition : DC 5 V charging mode (Coil#1)

Radiated Emissions			Ant.	Correction Factors		Total		FCC Limit	
Frequency (MHz)	Reading (dB $\mu$ V)	Detect Mode	Pol.	Ant. (dB/m)	Cable (dB)	Actual (dB $\mu$ V/m) at 3 m	Actual (dB $\mu$ V/m) at 300 m	Limit (dB $\mu$ V/m) at 300 m	Margin (dB)
Charging mode with client (less than 1 % battery status)									
0.144	54.20	Average	H	19.58	0.05	73.83	-6.17	24.44	30.61
Charging mode with client (less than 50 % battery status)									
0.143	54.60	Average	H	19.58	0.05	74.23	-5.77	24.50	30.27
Charging mode with client (100 % battery status)									
0.143	53.80	Average	H	19.58	0.05	73.43	-6.57	24.50	31.07

### Test condition : DC 9 V charging mode (Coil#1)

Radiated Emissions			Ant.	Correction Factors		Total		FCC Limit	
Frequency (MHz)	Reading (dB $\mu$ V)	Detect Mode	Pol.	Ant. (dB/m)	Cable (dB)	Actual (dB $\mu$ V/m) at 3 m	Actual (dB $\mu$ V/m) at 300 m	Limit (dB $\mu$ V/m) at 300 m	Margin (dB)
Charging mode with client (less than 1 % battery status)									
0.147	57.20	Average	H	19.58	0.05	76.83	-3.17	24.26	27.43
Charging mode with client (less than 50 % battery status)									
0.147	55.40	Average	H	19.58	0.05	75.03	-4.97	24.26	29.23
Charging mode with client (100 % battery status)									
0.147	54.30	Average	H	19.58	0.05	73.93	-6.07	24.26	30.33

The results shown in this test report refer only to the sample(s) tested unless otherwise stated. This test report cannot be reproduced, except in full, without prior written permission of the Company.

**Test condition : DC 5 V charging mode (Coil#2)**

Radiated Emissions			Ant.	Correction Factors		Total		FCC Limit	
Frequency (MHz)	Reading (dB $\mu$ V)	Detect Mode	Pol.	Ant. (dB/m)	Cable (dB)	Actual (dB $\mu$ V/m) at 3 m	Actual (dB $\mu$ V/m) at 300 m	Limit (dB $\mu$ V/m) at 300 m	Margin (dB)
Charging mode with client (less than 1 % battery status)									
0.139	54.20	Average	H	19.58	0.05	73.83	-6.17	24.74	30.91
Charging mode with client (less than 50 % battery status)									
0.138	54.90	Average	H	19.58	0.05	74.53	-5.47	24.81	30.28
Charging mode with client (100 % battery status)									
0.138	54.31	Average	H	19.58	0.05	73.94	-6.06	24.81	30.87

**Test condition : DC 9 V charging mode (Coil#2)**

Radiated Emissions			Ant.	Correction Factors		Total		FCC Limit	
Frequency (MHz)	Reading (dB $\mu$ V)	Detect Mode	Pol.	Ant. (dB/m)	Cable (dB)	Actual (dB $\mu$ V/m) at 3 m	Actual (dB $\mu$ V/m) at 300 m	Limit (dB $\mu$ V/m) at 300 m	Margin (dB)
Charging mode with client (less than 1 % battery status)									
0.144	55.30	Average	H	19.58	0.05	74.93	-5.07	24.44	29.51
Charging mode with client (less than 50 % battery status)									
0.144	56.80	Average	H	19.58	0.05	76.43	-3.57	24.44	28.01
Charging mode with client (100 % battery status)									
0.144	57.00	Average	H	19.58	0.05	76.63	-3.37	24.44	27.81

**Note;**

1. According to §15.31 (f)(2) 300 m Result(dB $\mu$ V/m) = 3 m Result(dB $\mu$ V/m) – 40log(300/3) (dB $\mu$ V/m).
2. According to §15.209 (d), the measurements were tested by using Quasi peak detector except for the frequency bands 9 – 90 kHz, 110 – 490 kHz and above 1 GHz in these three bands on measurements employing an average detector.
3. The limit above was calculated based on table of §15.209 (a).

The results shown in this test report refer only to the sample(s) tested unless otherwise stated. This test report cannot be reproduced, except in full, without prior written permission of the Company.

## 2.5. Spurious Emission Test Result

Ambient temperature : (24 ± 1) °C  
 Relative humidity : 47 % R.H.

The following table shows the highest levels of radiated emissions on both polarizations of horizontal and vertical.

**Test condition : DC 5 V charging mode (Coil#1)**

**Charging mode with client device (less than 1 % battery status)**

Radiated Emissions			Ant.	Correction Factors		Total		Limit	
Frequency (MHz)	Reading (dB $\mu$ V)	Detect Mode	Pol.	Ant. (dB/m)	Cable (dB)	Actual (dB $\mu$ V/m) at 3 m	Actual (dB $\mu$ V/m) at 300 m or 30 m	Limit (dB $\mu$ V/m) at 300 m or 30 m	Margin (dB)
0.034	7.40	Average	H	19.70	0.02	27.12	-52.88	36.97	89.85
0.068	11.10	Average	H	19.66	0.04	30.80	-49.20	30.95	80.15
0.094	25.10	Quasi Peak	H	19.61	0.05	44.76	-35.24	28.14	63.38
0.102	12.30	Quasi Peak	H	19.60	0.05	31.95	-48.05	27.43	75.48
0.432	35.60	Average	H	19.43	0.04	55.07	-24.93	14.89	39.82
0.720	28.80	Quasi Peak	H	19.40	0.04	48.24	8.24	30.46	22.22
Above 0.800	Not detected	-	-	-	-	-	-	-	-

*The results shown in this test report refer only to the sample(s) tested unless otherwise stated. This test report cannot be reproduced, except in full, without prior written permission of the Company.*

**Charging mode with client device (less than 50 % battery status)**

Radiated Emissions			Ant.	Correction Factors		Total		Limit	
Frequency (MHz)	Reading (dB $\mu$ V)	Detect Mode	Pol.	Ant. (dB/m)	Cable (dB)	Actual (dB $\mu$ V/m) at 3 m	Actual (dB $\mu$ V/m) at 300 m or 30 m	Limit (dB $\mu$ V/m) at 300 m or 30 m	Margin (dB)
0.038	10.60	Average	H	19.70	0.02	30.32	-49.68	36.01	85.69
0.076	13.20	Average	H	19.65	0.04	32.89	-47.11	29.99	77.10
0.094	25.00	Quasi Peak	H	19.61	0.05	44.66	-35.34	28.14	63.48
0.113	11.70	Average	H	19.59	0.05	31.34	-48.66	26.54	75.20
0.432	34.70	Average	H	19.43	0.04	54.17	-25.83	14.89	40.72
0.719	28.10	Quasi Peak	H	19.40	0.04	47.54	7.54	30.47	22.93
Above 0.800	Not detected	-	-	-	-	-	-	-	-

**Charging mode with client device (100 % battery status)**

Radiated Emissions			Ant.	Correction Factors		Total		Limit	
Frequency (MHz)	Reading (dB $\mu$ V)	Detect Mode	Pol.	Ant. (dB/m)	Cable (dB)	Actual (dB $\mu$ V/m) at 3 m	Actual (dB $\mu$ V/m) at 300 m or 30 m	Limit (dB $\mu$ V/m) at 300 m or 30 m	Margin (dB)
0.094	25.00	Quasi Peak	H	19.61	0.05	44.66	-35.34	28.14	63.48
0.738	26.63	Quasi Peak	H	19.40	0.04	46.07	6.07	30.24	24.17
1.030	24.00	Quasi Peak	H	19.40	0.03	43.43	3.43	27.35	23.92
Above 1.100	Not detected	-	-	-	-	-	-	-	-

The results shown in this test report refer only to the sample(s) tested unless otherwise stated. This test report cannot be reproduced, except in full, without prior written permission of the Company.

**Test condition : DC 9 V charging mode (Coil#1)**
**Charging mode with client device (less than 1 % battery status)**

Radiated Emissions			Ant.	Correction Factors		Total		Limit	
Frequency (MHz)	Reading (dB $\mu$ V)	Detect Mode	Pol.	Ant. (dB/m)	Cable (dB)	Actual (dB $\mu$ V/m) at 3 m	Actual (dB $\mu$ V/m) at 300 m or 30 m	Limit (dB $\mu$ V/m) at 300 m or 30 m	Margin (dB)
0.094	25.21	Quasi Peak	H	19.61	0.05	44.87	-35.13	28.14	63.27
0.115	0.50	Average	H	19.59	0.05	20.14	-59.86	26.39	86.25
0.135	5.10	Average	H	19.58	0.05	24.73	-55.27	25.00	80.27
0.443	34.94	Average	H	19.43	0.04	54.41	-25.59	14.68	40.27
0.737	28.60	Quasi Peak	H	19.40	0.04	48.04	8.04	30.25	22.21
Above 0.800	Not detected	-	-	-	-	-	-	-	-

**Charging mode with client device (less than 50 % battery status)**

Radiated Emissions			Ant.	Correction Factors		Total		Limit	
Frequency (MHz)	Reading (dB $\mu$ V)	Detect Mode	Pol.	Ant. (dB/m)	Cable (dB)	Actual (dB $\mu$ V/m) at 3 m	Actual (dB $\mu$ V/m) at 300 m or 30 m	Limit (dB $\mu$ V/m) at 300 m or 30 m	Margin (dB)
0.036	6.30	Average	H	19.70	0.02	26.02	-53.98	36.48	90.46
0.094	26.30	Quasi Peak	H	19.61	0.05	45.96	-34.04	28.14	62.18
0.441	32.50	Average	H	19.43	0.04	51.97	-28.03	14.72	42.75
0.735	33.30	Quasi Peak	H	19.40	0.04	52.74	12.74	30.28	17.54
Above 0.800	Not detected	-	-	-	-	-	-	-	-

The results shown in this test report refer only to the sample(s) tested unless otherwise stated. This test report cannot be reproduced, except in full, without prior written permission of the Company.

**Charging mode with client device (100 % battery status)**

Radiated Emissions			Ant.	Correction Factors		Total		Limit	
Frequency (MHz)	Reading (dB $\mu$ V)	Detect Mode	Pol.	Ant. (dB/m)	Cable (dB)	Actual (dB $\mu$ V/m) at 3 m	Actual (dB $\mu$ V/m) at 300 m or 30 m	Limit (dB $\mu$ V/m) at 300 m or 30 m	Margin (dB)
0.036	5.50	Average	H	19.70	0.02	25.22	-54.78	36.48	91.26
0.094	26.30	Quasi Peak	H	19.61	0.05	45.96	-34.04	28.14	62.18
0.738	30.50	Quasi Peak	H	19.40	0.04	49.94	9.94	30.24	20.30
1.030	26.20	Quasi Peak	H	19.40	0.03	45.63	5.63	27.35	21.72
Above 1.100	Not detected	-	-	-	-	-	-	-	-

The results shown in this test report refer only to the sample(s) tested unless otherwise stated. This test report cannot be reproduced, except in full, without prior written permission of the Company.

**Test condition : DC 5 V charging mode (Coil#2)**
**Charging mode with client device (less than 1 % battery status)**

Radiated Emissions			Ant.	Correction Factors		Total		Limit	
Frequency (MHz)	Reading (dB $\mu$ V)	Detect Mode	Pol.	Ant. (dB/m)	Cable (dB)	Actual (dB $\mu$ V/m) at 3 m	Actual (dB $\mu$ V/m) at 300 m or 30 m	Limit (dB $\mu$ V/m) at 300 m or 30 m	Margin (dB)
0.038	11.70	Average	H	19.70	0.02	31.42	-48.58	36.01	84.59
0.076	16.50	Average	H	19.65	0.04	36.19	-43.81	29.99	73.80
0.094	26.30	Quasi Peak	H	19.61	0.05	45.96	-34.04	28.14	62.18
0.114	14.70	Average	H	19.59	0.05	34.34	-45.66	26.47	72.13
0.416	36.60	Average	H	19.44	0.04	56.08	-23.92	15.22	39.14
0.694	31.20	Quasi Peak	H	19.40	0.04	50.64	10.64	30.78	20.14
Above 0.700	Not detected	-	-	-	-	-	-	-	-

**Charging mode with client device (less than 50 % battery status)**

Radiated Emissions			Ant.	Correction Factors		Total		Limit	
Frequency (MHz)	Reading (dB $\mu$ V)	Detect Mode	Pol.	Ant. (dB/m)	Cable (dB)	Actual (dB $\mu$ V/m) at 3 m	Actual (dB $\mu$ V/m) at 300 m or 30 m	Limit (dB $\mu$ V/m) at 300 m or 30 m	Margin (dB)
0.036	6.20	Average	H	19.70	0.02	25.92	-54.08	36.48	90.56
0.094	24.80	Quasi Peak	H	19.61	0.05	44.46	-35.54	28.14	63.68
0.415	36.40	Average	H	19.44	0.04	55.88	-24.12	15.24	39.36
0.644	30.30	Quasi Peak	H	19.40	0.04	49.74	9.74	31.43	21.69
Above 0.700	Not detected	-	-	-	-	-	-	-	-

The results shown in this test report refer only to the sample(s) tested unless otherwise stated. This test report cannot be reproduced, except in full, without prior written permission of the Company.

**Charging mode with client device (100 % battery status)**

Radiated Emissions			Ant.	Correction Factors		Total		Limit	
Frequency (MHz)	Reading (dB $\mu$ V)	Detect Mode	Pol.	Ant. (dB/m)	Cable (dB)	Actual (dB $\mu$ V/m) at 3 m	Actual (dB $\mu$ V/m) at 300 m or 30 m	Limit (dB $\mu$ V/m) at 300 m or 30 m	Margin (dB)
0.039	13.70	Average	H	19.70	0.02	33.42	-46.58	35.78	82.36
0.077	13.90	Average	H	19.65	0.04	33.59	-46.41	29.87	76.28
0.094	25.20	Quasi Peak	H	19.61	0.05	44.86	-35.14	28.14	63.28
0.122	7.50	Average	H	19.59	0.05	27.14	-52.86	25.88	78.74
0.434	33.90	Average	H	19.43	0.04	53.37	-26.63	14.85	41.48
0.724	28.70	Quasi Peak	H	19.40	0.04	48.14	8.14	30.41	22.27
Above 0.800	Not detected	-	-	-	-	-	-	-	-

The results shown in this test report refer only to the sample(s) tested unless otherwise stated. This test report cannot be reproduced, except in full, without prior written permission of the Company.

**Test condition : DC 9 V charging mode (Coil#2)**
**Charging mode with client device (less than 1 % battery status)**

Radiated Emissions			Ant.	Correction Factors		Total		Limit	
Frequency (MHz)	Reading (dB $\mu$ V)	Detect Mode	Pol.	Ant. (dB/m)	Cable (dB)	Actual (dB $\mu$ V/m) at 3 m	Actual (dB $\mu$ V/m) at 300 m or 30 m	Limit (dB $\mu$ V/m) at 300 m or 30 m	Margin (dB)
0.036	6.60	Average	H	19.70	0.02	26.32	-53.68	36.48	90.16
0.094	26.10	Quasi Peak	H	19.61	0.05	45.76	-34.24	28.14	62.38
0.134	10.91	Average	H	19.58	0.05	30.54	-49.46	25.06	74.52
0.433	34.70	Average	H	19.43	0.04	54.17	-25.83	14.87	40.70
0.721	28.84	Quasi Peak	H	19.40	0.04	48.28	8.28	30.45	22.17
Above 0.800	Not detected	-	-	-	-	-	-	-	-

**Charging mode with client device (less than 50 % battery status)**

Radiated Emissions			Ant.	Correction Factors		Total		Limit	
Frequency (MHz)	Reading (dB $\mu$ V)	Detect Mode	Pol.	Ant. (dB/m)	Cable (dB)	Actual (dB $\mu$ V/m) at 3 m	Actual (dB $\mu$ V/m) at 300 m or 30 m	Limit (dB $\mu$ V/m) at 300 m or 30 m	Margin (dB)
0.036	6.92	Average	H	19.70	0.02	26.64	-53.36	36.48	89.84
0.094	25.10	Quasi Peak	H	19.61	0.05	44.76	-35.24	28.14	63.38
0.122	9.00	Average	H	19.59	0.05	28.64	-51.36	25.88	77.24
0.432	37.60	Average	H	19.43	0.04	57.07	-22.93	14.89	37.82
0.722	31.80	Quasi Peak	H	19.40	0.04	51.24	11.24	30.43	19.19
Above 0.800	Not detected	-	-	-	-	-	-	-	-

The results shown in this test report refer only to the sample(s) tested unless otherwise stated. This test report cannot be reproduced, except in full, without prior written permission of the Company.

**Charging mode with client device (100 % battery status)**

Radiated Emissions			Ant.	Correction Factors		Total		Limit	
Frequency (MHz)	Reading (dB $\mu$ V)	Detect Mode	Pol.	Ant. (dB/m)	Cable (dB)	Actual (dB $\mu$ V/m) at 3 m	Actual (dB $\mu$ V/m) at 300 m or 30 m	Limit (dB $\mu$ V/m) at 300 m or 30 m	Margin (dB)
0.036	6.80	Average	H	19.70	0.02	26.52	-53.48	36.48	89.96
0.094	25.20	Quasi Peak	H	19.61	0.05	44.86	-35.14	28.14	63.28
0.122	8.92	Average	H	19.59	0.05	28.56	-51.44	25.88	77.32
0.410	39.70	Average	H	19.45	0.04	59.19	-20.81	15.35	36.16
0.725	34.94	Quasi Peak	H	19.40	0.04	54.38	14.38	30.40	16.02
Above 0.800	Not detected	-	-	-	-	-	-	-	-

**Note;**

- According to §15.31 (f)(2)
  - 300 m Result(dB $\mu$ V/m) = 3 m Result(dB $\mu$ V/m) – 40log(300/3) (dB $\mu$ V/m)
  - 30 m Result(dB $\mu$ V/m) = 3 m Result(dB $\mu$ V/m) – 40log(30/3) (dB $\mu$ V/m)
- According to field strength table of general requirement in §15.209 (a), field strength limits below 1.705 MHz were calculated as below.
  - 9 kHz to 490 kHz : 20log(2 400 / F (kHz)) at 300 m (dB $\mu$ V/m)
  - 490 kHz to 1 705 kHz : 20log(24 000 / F (kHz)) at 30 m (dB $\mu$ V/m)
- According to §15.209 (d), the measurements were tested by using Quasi peak detector except for the frequency bands 9 – 90 kHz, 110 – 490 kHz and above 1 GHz in these three bands on measurements employing an average detector.

The results shown in this test report refer only to the sample(s) tested unless otherwise stated. This test report cannot be reproduced, except in full, without prior written permission of the Company.

### 3. 20 dB Bandwidth

#### 3.1. Test Setup

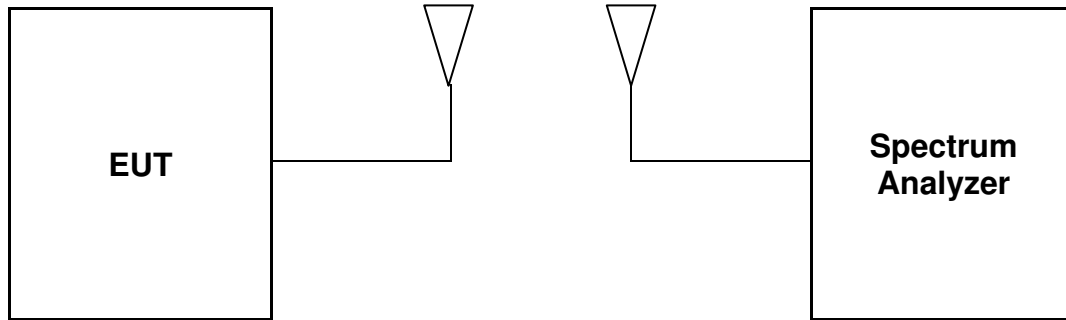

#### 3.2. Limit

None; for reporting purposed only

#### 3.3. Test Procedure

##### 20 dB Bandwidth

- a. Span = approximately 2 to 3 times the 20 dB bandwidth, RBW = greater than 1 % of the 20 dB bandwidth, VBW = RBW, Sweep = auto, Detector = peak, Trace = max hold.
- b. The marker-to-peak function to set the mark to the peak of the emission. Use the marker-delta function to measure 20 dB down one side of the emission. Reset the function, and move the marker to the other side of the emission, until it is (as close as possible to) even with the reference marker level. The marker-delta reading at this point is 20 dB bandwidth of the emission.

*The results shown in this test report refer only to the sample(s) tested unless otherwise stated. This test report cannot be reproduced, except in full, without prior written permission of the Company.*

### 3.4. Test Result

Ambient temperature : (24 ± 1) °C  
 Relative humidity : 47 % R.H.

**Test condition : DC 5 V charging mode**

EUT status	20 dB Bandwidth (kHz)	Limit
With client device (100 % of battery)	0.517	Reporting proposed only

#### 20 dB Bandwidth

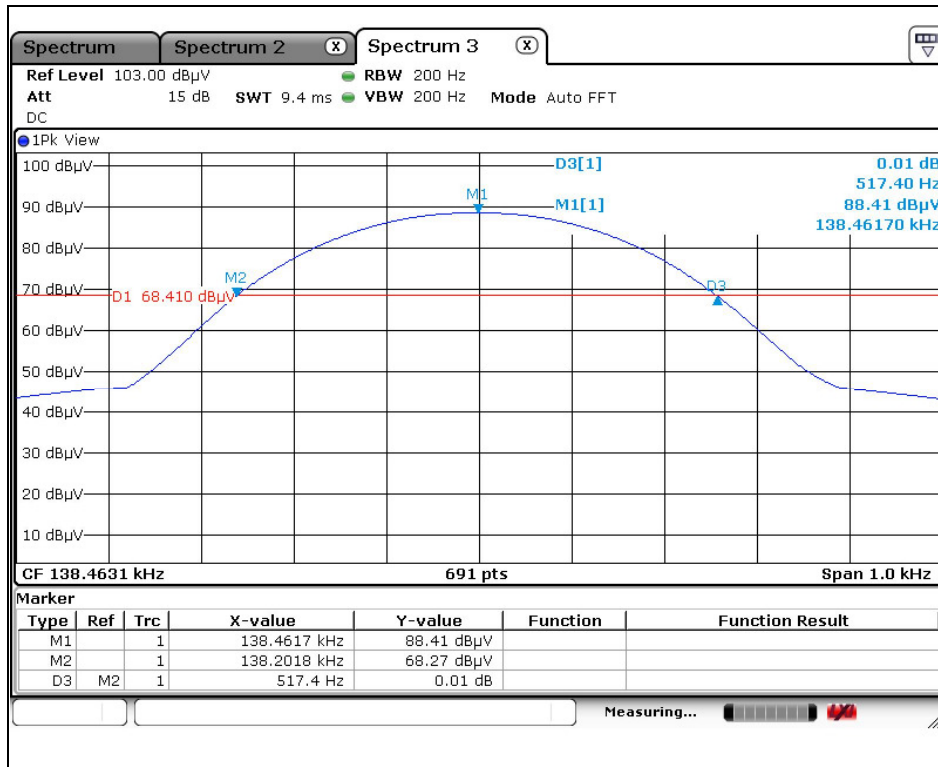

The results shown in this test report refer only to the sample(s) tested unless otherwise stated. This test report cannot be reproduced, except in full, without prior written permission of the Company.

**Test condition : DC 9 V charging mode**

EUT status	20 dB Bandwidth (kHz)	Limit
With client device (100 % of battery)	0.531	Reporting proposed only

**20 dB Bandwidth**

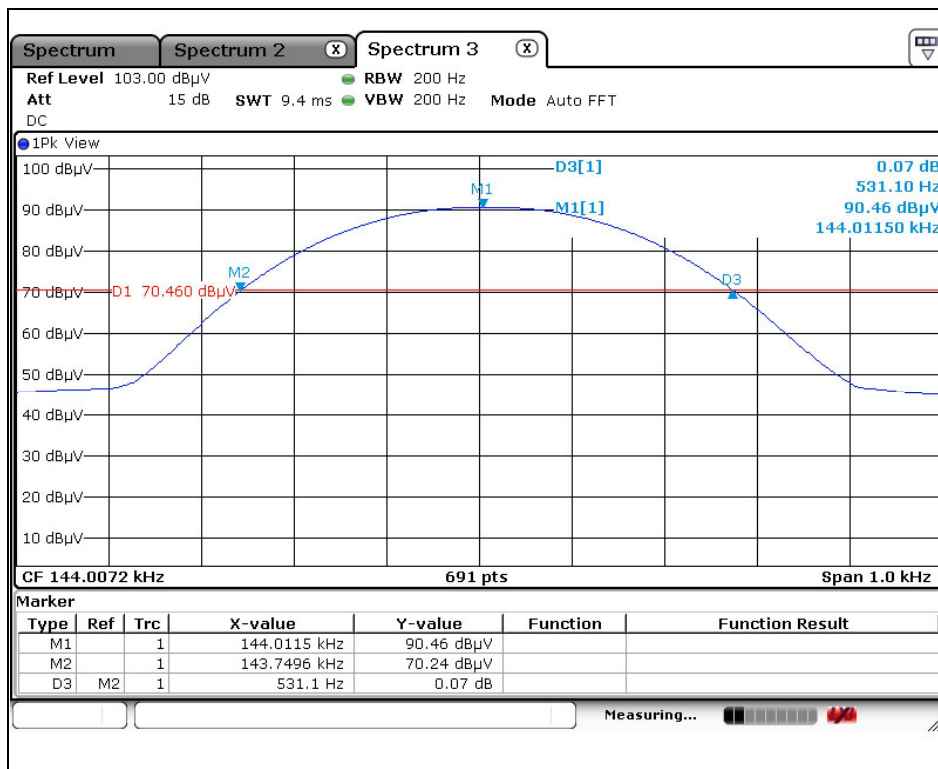

**Note ;**

1. All antennas of operation were investigated and the worst-case antenna was reported considered the highest exposure.

The results shown in this test report refer only to the sample(s) tested unless otherwise stated. This test report cannot be reproduced, except in full, without prior written permission of the Company.

## 4. Transmitter AC Power Line Conducted Emission

### 4.1. Test Setup

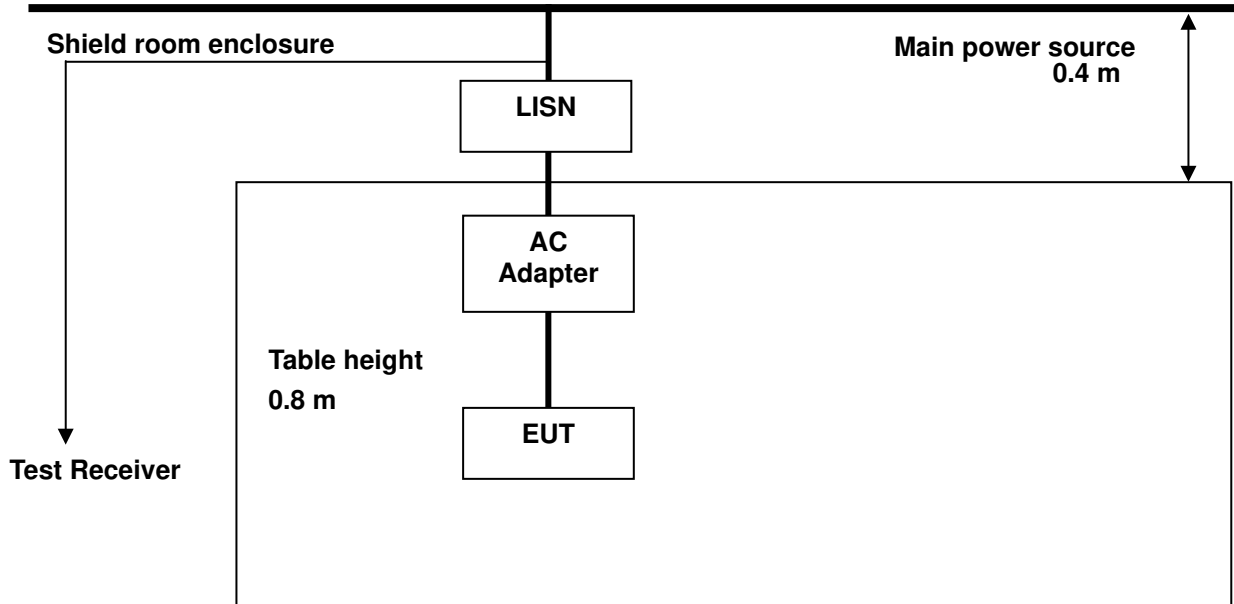

### 4.2. Limit

According to §15.207(a) for an intentional radiator that is designed to be connected to the public utility (AC) power line, the radio frequency voltage that is conducted back onto the AC power line on any frequency or frequencies, within the band 150 kHz to 30 MHz, shall not exceed the limits in the following table, as measured using a 50  $\mu$ H / 50 ohm line impedance stabilization network(LISN).

Compliance with the provision of this paragraph shall on the measurement of the radio frequency voltage between each power line and ground at the power terminal. The lower applies at the boundary between the frequency ranges.

Frequency of Emission (MHz)	Conducted limit (dB $\mu$ V)	
	Quasi-peak	Average
0.15 – 0.50	66 - 56*	56 - 46*
0.50 – 5.00	56	46
5.00 – 30.0	60	50

\* Decreases with the logarithm of the frequency.

The results shown in this test report refer only to the sample(s) tested unless otherwise stated. This test report cannot be reproduced, except in full, without prior written permission of the Company.

### 4.3. Test Procedures

AC conducted emissions from the EUT were measured according to the dictates of ANSI C63.10:2009

1. The test procedure is performed in a 6.5 m × 3.5 m × 3.5 m (L × W × H) shielded room. The EUT along with its peripherals were placed on a 1.0 m (W) × 1.5 m (L) and 0.8 m in height wooden table and the EUT was adjusted to maintain a 0.4 meter space from a vertical reference plane.
2. The EUT was connected to power mains through a line impedance stabilization network (LISN) which provides 50 ohm coupling impedance for measuring instrument and the chassis ground was bounded to the horizontal ground plane of shielded room.
3. All peripherals were connected to the second LISN and the chassis ground also bounded to the horizontal ground plane of shielded room.
4. The excess power cable between the EUT and the LISN was bundled. The power cables of peripherals were unbundled. All connecting cables of EUT and peripherals were moved to find the maximum emission.

*The results shown in this test report refer only to the sample(s) tested unless otherwise stated. This test report cannot be reproduced, except in full, without prior written permission of the Company.*

#### 4.4. Test Results

The following table shows the highest levels of conducted emissions on both phase of Hot and Neutral line.

Ambient temperature : (24 ± 1) °C  
 Relative humidity : 47 % R.H.  
  
 Frequency range : 0.15 MHz – 30 MHz  
 Measured Bandwidth : 9 kHz

#### Test condition : DC 5 V charging mode (Coil#1)

#### Charging mode with Client device (1 % status)

FREQ. (MHz)	LEVEL(dB $\mu$ V)		LINE	LIMIT(dB $\mu$ V)		MARGIN(dB)	
	Q-Peak	Average		Q-Peak	Average	Q-Peak	Average
0.15	29.30	25.00	N	66.00	56.00	36.70	31.00
0.19	53.00	41.40	N	64.04	54.04	11.04	12.64
0.22	49.20	36.90	N	62.82	52.82	13.62	15.92
0.29	44.10	34.30	N	60.52	50.52	16.42	16.22
0.80	40.60	33.30	N	56.00	46.00	15.40	12.70
2.06	34.40	29.40	N	56.00	46.00	21.60	16.60
0.15	60.10	47.20	H	66.00	56.00	5.90	8.80
0.18	55.20	41.50	H	64.49	54.49	9.29	12.99
0.30	48.50	38.50	H	60.24	50.24	11.74	11.74
0.48	37.20	26.40	H	56.34	46.34	19.14	19.94
0.80	42.20	35.10	H	56.00	46.00	13.80	10.90
2.65	42.20	35.10	H	56.00	46.00	13.80	10.90

#### Note ;

- Line ( H ): Hot, Line ( N ): Neutral
- All antennas of operation and charging mode with client device (1 %, 50 %, and 100 % of battery) were tested.  
As worst condition, Antenna of Coil#1 and charging mode with client device (1 %) is reported.
- The limit for Class B device(s) from 150 kHz to 30 MHz are specified in Section of the Title 47 CFR.
- Traces shown in plot were made by using a peak detector and average detector.
- Deviations to the Specifications: None.

The results shown in this test report refer only to the sample(s) tested unless otherwise stated. This test report cannot be reproduced, except in full, without prior written permission of the Company.

Test mode: (Neutral)

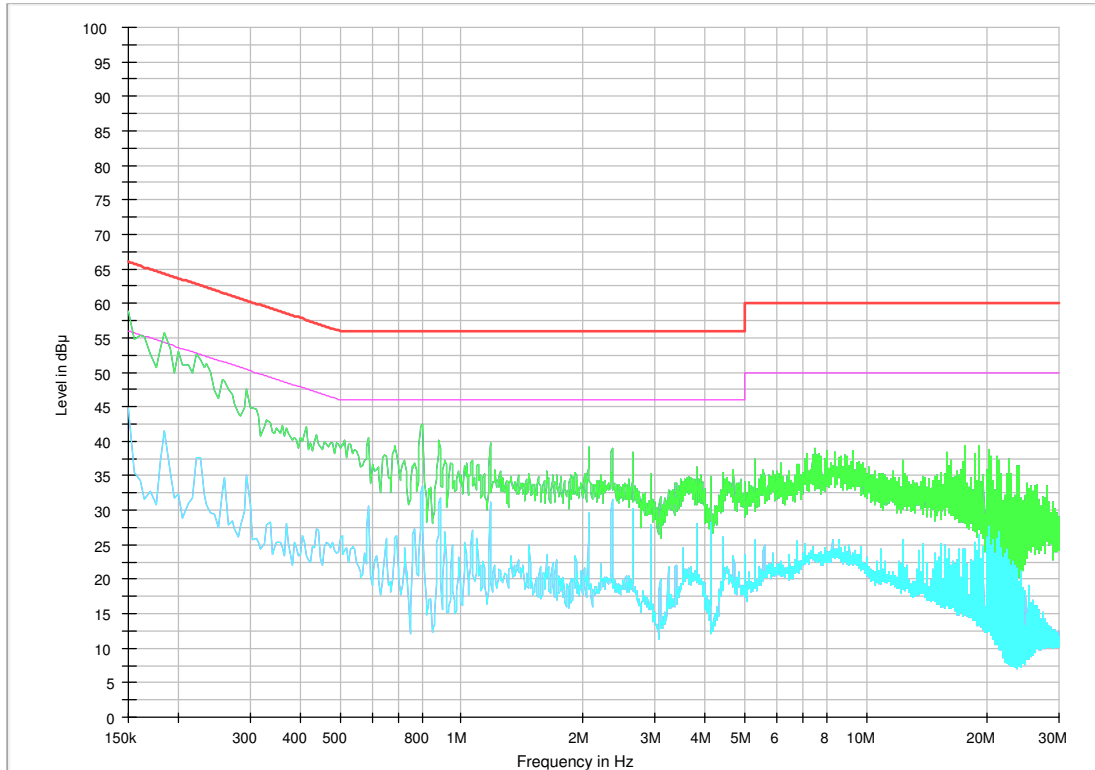

The results shown in this test report refer only to the sample(s) tested unless otherwise stated. This test report cannot be reproduced, except in full, without prior written permission of the Company.

Test mode: (Hot)

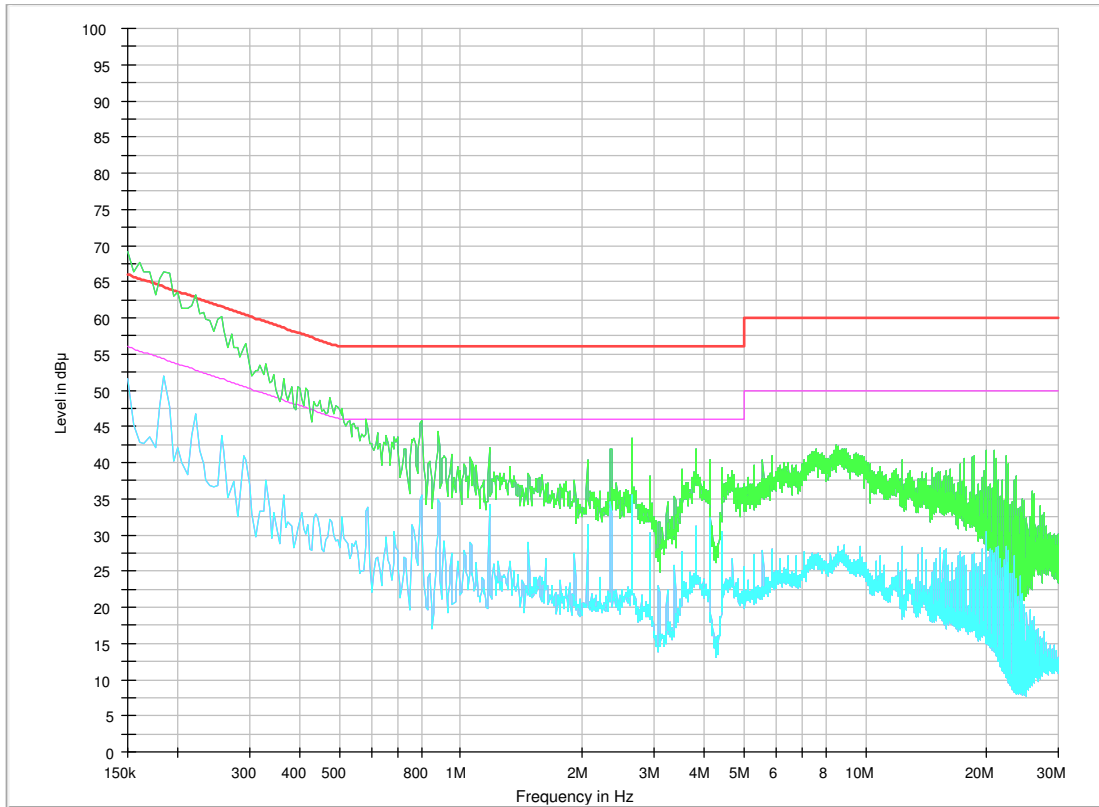

The results shown in this test report refer only to the sample(s) tested unless otherwise stated. This test report cannot be reproduced, except in full, without prior written permission of the Company.

**Test condition : DC 9 V charging mode (Coil#1)**
**Charging mode with Client device (1 % status)**

FREQ. (MHz)	LEVEL(dB $\mu$ V)		LINE	LIMIT(dB $\mu$ V)		MARGIN(dB)	
	Q-Peak	Average		Q-Peak	Average	Q-Peak	Average
0.15	42.90	27.20	N	66.00	56.00	23.10	28.80
0.59	40.20	36.10	N	56.00	46.00	15.80	9.90
0.83	30.40	17.90	N	56.00	46.00	25.60	28.10
2.35	37.30	28.60	N	56.00	46.00	18.70	17.40
2.65	40.50	34.50	N	56.00	46.00	15.50	11.50
5.57	41.00	33.80	N	60.00	50.00	19.00	16.20
0.15	50.30	35.50	H	66.00	56.00	15.70	20.50
0.30	45.50	40.80	H	60.24	50.24	14.74	9.44
0.59	44.30	38.50	H	56.00	46.00	11.70	7.50
0.88	39.00	30.30	H	56.00	46.00	17.00	15.70
2.94	44.00	37.80	H	56.00	46.00	12.00	8.20
6.02	43.10	34.80	H	60.00	50.00	16.90	15.20

**Note ;**

- Line ( H ): Hot, Line ( N ): Neutral
- All antennas of operation and charging mode with client device (1 %, 50 %, and 100 % of battery) were tested.  
As worst condition, Antenna of Coil#1 and charging mode with client device (1 %) is reported.
- The limit for Class B device(s) from 150 kHz to 30 MHz are specified in Section of the Title 47 CFR.
- Traces shown in plot were made by using a peak detector and average detector.
- Deviations to the Specifications: None.

*The results shown in this test report refer only to the sample(s) tested unless otherwise stated. This test report cannot be reproduced, except in full, without prior written permission of the Company.*

Test mode: (Neutral)

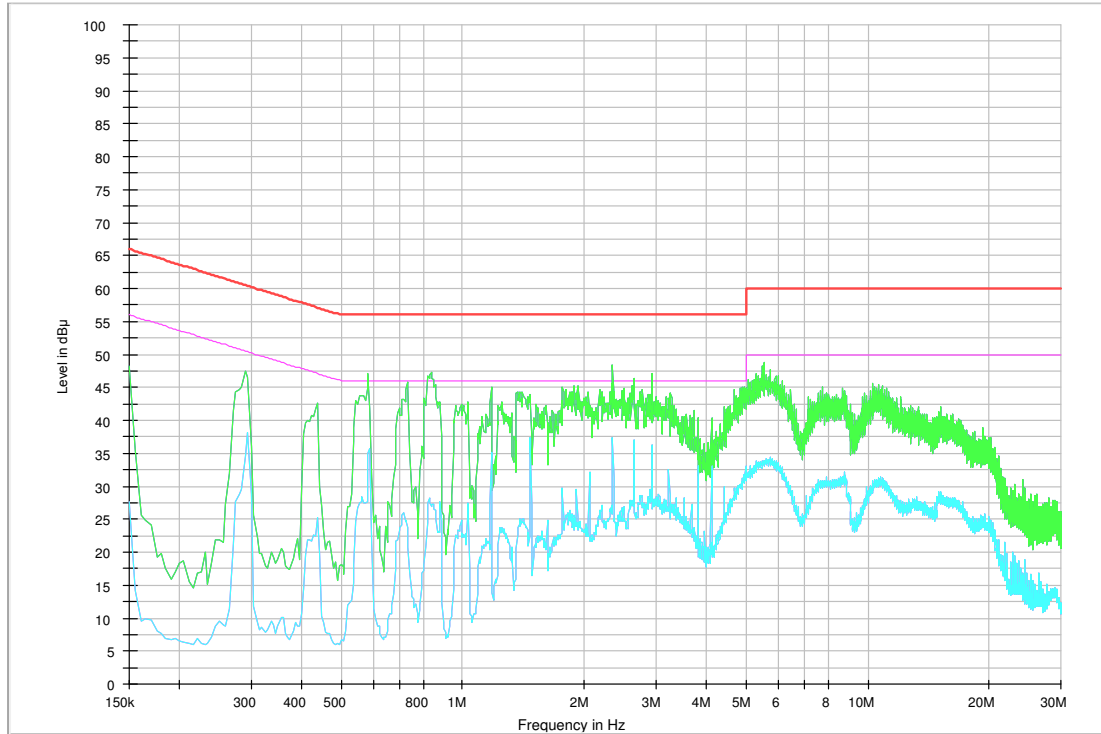

The results shown in this test report refer only to the sample(s) tested unless otherwise stated. This test report cannot be reproduced, except in full, without prior written permission of the Company.

Test mode: (Hot)

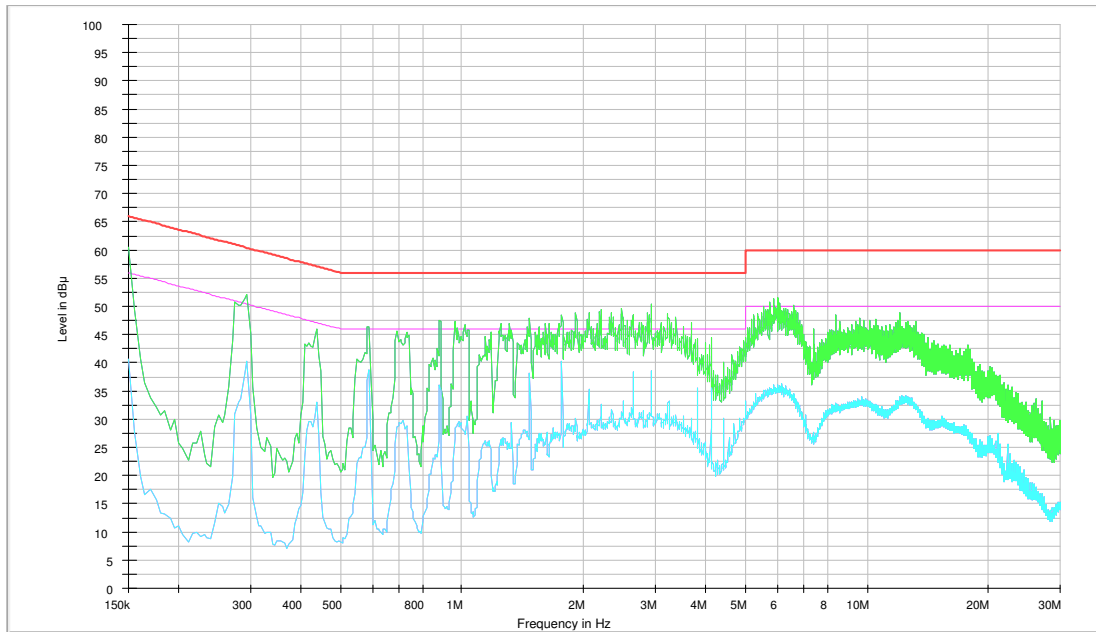

The results shown in this test report refer only to the sample(s) tested unless otherwise stated. This test report cannot be reproduced, except in full, without prior written permission of the Company.