

TEST REPORT

of

FCC Part 15 Subpart C §15.247

FCC ID : A3LEKGC110

Equipment Under Test : Mobile imaging device
Model Name : EK-GC110
Serial No. : N/A
Applicant : SAMSUNG ELECTRONICS CO., LTD.
Manufacturer : SAMSUNG ELECTRONICS CO., LTD.
Date of Test(s) : 2013.01.28 ~ 2013.02.07
Date of Issue : 2013.02.13

In the configuration tested, the EUT complied with the standards specified above.

Tested By:



Date:

2013.02.13

Harim Lee

Approved By:



Date:

2013.02.13

Denny Ham

The results shown in this test report refer only to the sample(s) tested unless otherwise stated. This test report cannot be reproduced, except in full, without prior written permission of the Company.

INDEX

Table of contents

1. General information -----	3
2. Transmitter radiated spurious emissions and conducted spurious emission -----	6
3. 6 dB bandwidth -----	55
4. Maximum conducted output power -----	66
5. Power Spectral Density -----	71
6. Transmitter AC Power Line Conducted Emission-----	82
7. Antenna Requirement -----	87

The results shown in this test report refer only to the sample(s) tested unless otherwise stated. This test report cannot be reproduced, except in full, without prior written permission of the Company.

1. General Information

1.1. Testing Laboratory

SGS Korea Co., Ltd. (Gunpo Laboratory)

- Wireless Div. 3FL, 18-34, Sanbon-dong, Gunpo-si, Gyeonggi-do, Korea 435-040

All SGS services are rendered in accordance with the applicable SGS conditions of service available on request and accessible at <http://www.sgs.com/en/Terms-and-Conditions.aspx>.

Telephone : +82 31 428 5700

FAX : +82 31 427 2371

1.2. Details of Applicant

Applicant : SAMSUNG ELECTRONICS CO., LTD.

Address : 129, Samsung-ro, Yeongtong-gu, Suwon-si, Gyeonggi-do, 443-742 Rep. of Korea

Contact Person : Choi, Jeong-Wook

Phone No. : +82 10 8900 2047

1.3 Description of EUT

Kind of Product	Mobile imaging device
Model Name	EK-GC110
Serial Number	N/A
Power Supply	DC 3.8 V
Frequency Range	2 412 MHz ~ 2 472 MHz (11b/g/n_HT20), 5 745 MHz ~ 5 805 MHz (11a/n_HT20), 5 755 MHz ~ 5 795 MHz (11n_HT40), 5 180 MHz ~ 5 240 MHz (11a/n_HT20 – Non DFS), 5 190 MHz ~ 5 230 MHz (11n_HT40 – Non DFS), 5 260 MHz ~ 5 320 MHz (11a/n_HT20 – DFS), 5 270 MHz ~ 5 310 MHz (11n_HT40 – DFS), 5 500 MHz ~ 5 700 MHz (11a/n_HT20 – DFS), 5 510 MHz ~ 5 670 MHz (11n_HT40 – DFS)
Modulation Technique	DSSS, OFDM
Number of Channels	11 channel (11b/g/n_HT20), 5 channel (11a/n_HT20), 2 channel (11n_HT40), 4 channel (11a/n_HT20–Non DFS), 2 channel (11n_HT40 – Non DFS), 15 channel (11a/n_HT20 - DFS), 7 channel (11n_HT40 - DFS)
Antenna Type	PIFA type
Antenna Gain	2 412 MHz ~ 2 462 MHz : -2.50 dB i 5 180 MHz ~ 5 320 MHz : 6.49 dB i 5 500 MHz ~ 5 700 MHz : 6.44 dB i 5 745 MHz ~ 5 825 MHz : 6.28 dB i
H/W Version	REV1.1
S/W Version	GC110.003

1.4. Declaration by the manufacturer

- Duty Cycle ≥ 98 percent.

The results shown in this test report refer only to the sample(s) tested unless otherwise stated. This test report cannot be reproduced, except in full, without prior written permission of the Company.

1.5. Test Equipment List

Equipment	Manufacturer	Model	S/N	Cal Date	Cal Interval	Cal Due.
Signal Generator	R&S	SMR40	100272	Aug. 23, 2012	Annual	Aug. 23, 2013
Spectrum Analyzer	Agilent	N9030A	US51350132	Oct. 30, 2012	Annual	Oct. 30, 2013
Spectrum Analyzer	R&S	FSV30	100955	Mar. 29, 2012	Annual	Mar. 29, 2013
Attenuator	AEROFLEX / INMET	18N – 20dB	2	Apr. 02, 2012	Annual	Apr. 02, 2013
High Pass Filter	Wainwright	WHK3.0/18G-10SS	344	Jul. 12, 2012	Annual	Jul. 12, 2013
High Pass Filter	Wainwright	WHK7.5//26.5G-6SS	11	Jul. 12, 2012	Annual	Jul. 12, 2013
Low Pass Filter	Mini-Circuits	NLP-1200+	V8979400903-1	Jul. 12, 2012	Annual	Jul. 12, 2013
Power Meter	Anritsu	ML2495A	1223004	Jul. 20, 2012	Annual	Jul. 20, 2013
Power Sensor	Anritsu	MF2411B	1207272	Jul. 20, 2012	Annual	Jul. 20, 2013
DC power Supply	Agilent	U8002A	MY49030063	Dec. 20, 2012	Annual	Dec. 20, 2013
Preamplifier	H.P.	8447F	2944A03909	Jul. 03, 2012	Annual	Jul. 03, 2013
Preamplifier	R&S	SCU18	10117	Jan. 14, 2013	Annual	Jan. 14, 2014
Preamplifier	MITEQ Inc.	JS44-18004000-35-8P	1546891	Jul. 12, 2012	Annual	Jul. 12, 2013
Test Receiver	R&S	ESU26	100109	Feb. 21, 2012	Annual	Feb. 21, 2013
Bilog Antenna	SCHWARZBECK	VULB9163	396	May 12, 2011	Biennial	May 12, 2013
Horn Antenna	SCHWARZBECK	BBHA9170	BBHA9170431	May 15, 2012	Biennial	May 15, 2014
Horn Antenna	R&S	HF 906	100326	Nov. 23, 2011	Biennial	Nov. 23, 2013
Antenna Master	INN-CO	MM4000	N/A	N/A	N/A	N.C.R.
Turn Table	INN-CO	DS 1200 S	N/A	N/A	N/A	N.C.R.
Test Receiver	R&S	ESHS10	863365/018	Jun. 04, 2012	Annual	Jun. 04, 2013
Two-Line V-Network	R&S	ENV216	100190	Jan. 04, 2013	Annual	Jan. 04, 2014
Anechoic Chamber	SY Corporation	L x W x H (6.5 m x 3.5 m x 3.5 m)	N/A	N/A	N/A	N.C.R.
Anechoic Chamber	SY Corporation	L x W x H (9.6 m x 6.4 m x 6.6 m)	N/A	N/A	N/A	N.C.R.

► Support equipment

Description	Manufacturer	Model	Serial Number
N/A	-	-	-

The results shown in this test report refer only to the sample(s) tested unless otherwise stated. This test report cannot be reproduced, except in full, without prior written permission of the Company.

1.6. Summary of Test Results

The EUT has been tested according to the following specifications:

APPLIED STANDARD: FCC Part15 Subpart C § 15.247		
Standard section	Test Item(s)	Result
15.205 15.209 15.247(d)	Transmitter Radiated Spurious Emissions Conducted Spurious Emission	Complied
15.247(a)(2)	6 dB Bandwidth	Complied
15.247(b)(3)	Maximum Conducted Output Power	Complied
15.247(e)	Power Spectral Density	Complied
15.207	Transmitter AC Power Line Conducted Emission	Complied

1.7. Test Procedure(s)

The measurement procedures described in the American National Standard for Testing Unlicensed Wireless Device (ANSI C63.10-2009) and the guidance provided in KDB 558074 were used in the measurement of the DUT.

1.8. Sample calculation

Where relevant, the following sample calculation is provided:

1.8.1. Conducted test

Offset value (dB) = Attenuator (dB) + Cable loss (dB)

1.8.2. Radiation test

Field strength level (dB μ V/m) = Measured level (dB μ V) + Antenna factor (dB) + Cable loss (dB) - amplifier gain(dB)

1.9. Test report revision

Revision	Report number	Description
0	F690501/RF-RTL006268	Initial

The results shown in this test report refer only to the sample(s) tested unless otherwise stated. This test report cannot be reproduced, except in full, without prior written permission of the Company.

2. Transmitter Radiated Spurious Emissions and Conducted Spurious Emission

2.1. Test Setup

2.1.1. Transmitter Radiated Spurious Emissions

The diagram below shows the test setup that is utilized to make the measurements for emission from 30 MHz to 1 GHz Emissions.

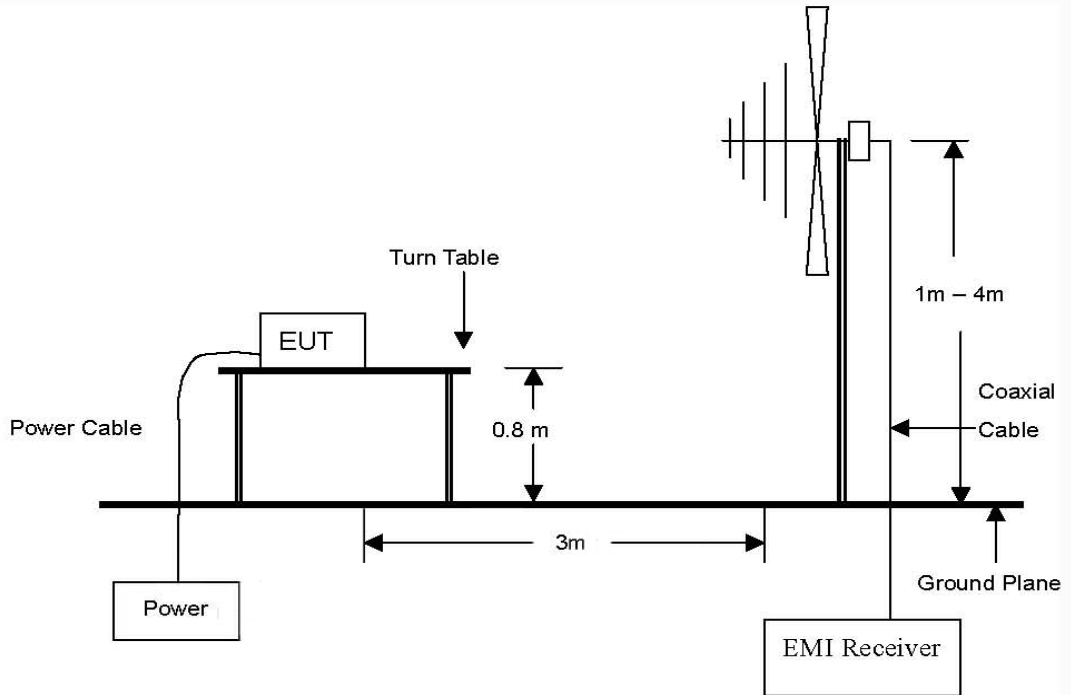

The diagram below shows the test setup that is utilized to make the measurements for emission. The spurious emissions were investigated from 1 GHz to the 10th harmonic of the highest fundamental frequency or 40 GHz, whichever is lower.

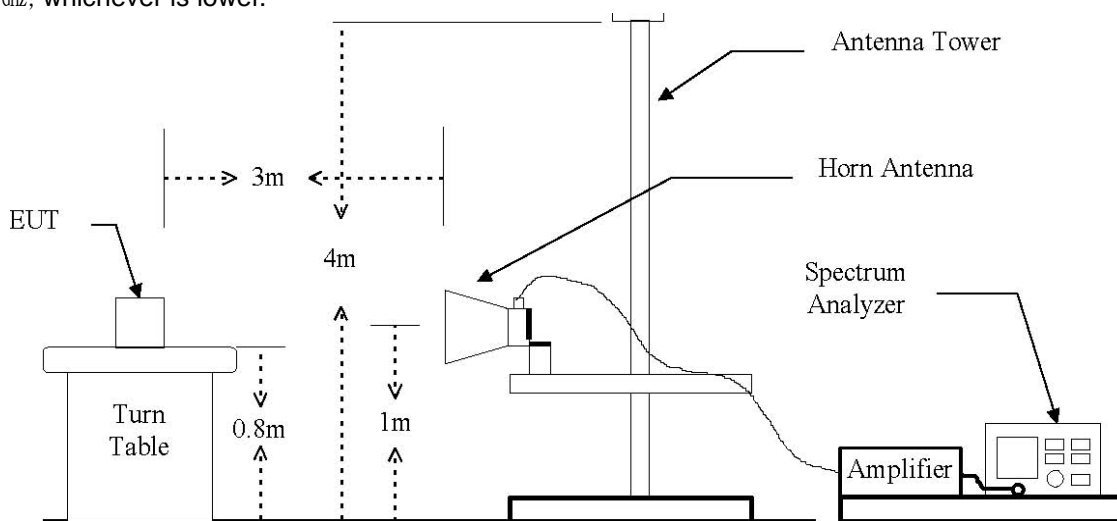

The results shown in this test report refer only to the sample(s) tested unless otherwise stated. This test report cannot be reproduced, except in full, without prior written permission of the Company.

2.1.2. Conducted Spurious Emission

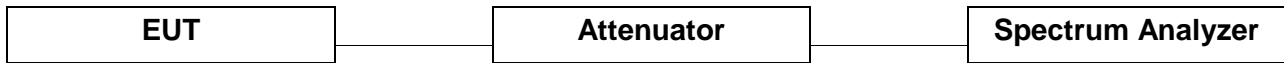

2.2. Limit

According to §15.247(d), in any 100 kHz bandwidth outside the frequency band in which the spread spectrum or digitally modulated intentional radiator is operating, the radio frequency power that is produced by the intentional radiator shall be at least 20 dB below that in the 100 kHz bandwidth within the band that contains the highest level of the desired power, based on either an RF conducted or a radiated measurement, provided the transmitter demonstrates compliance with the peak conducted power limits. If the transmitter complies with the conducted power limits based on the use of RMS averaging over a time interval, as permitted under paragraph(b)(3) of this section, the attenuation required under this paragraph shall be 30 dB instead of 20 dB. Attenuation below the general limits specified in section §15.209(a) is not required. In addition, radiated emission which in the restricted band, as define in section §15.205(a), must also comply the radiated emission limits specified in section §15.209(a) (see section §15.205(c))

According to § 15.209(a), Except as provided elsewhere in this Subpart, the emissions from an intentional radiator shall not exceed the field strength levels specified in the following table :

Frequency (MHz)	Distance (Meters)	Field Strength (dB μ V/m)	Field Strength (μ V/m)
30 - 88	3	40.0	100
88 – 216	3	43.5	150
216 – 960	3	46.0	200
Above 960	3	54.0	500

The results shown in this test report refer only to the sample(s) tested unless otherwise stated. This test report cannot be reproduced, except in full, without prior written permission of the Company.

2.3. Test Procedures

Radiated emissions from the EUT were measured according to the dictates in section 10.0 of KDB 558074

2.3.1. Test Procedures for Radiated Spurious Emissions

1. The EUT was placed on the top of a rotating table 0.8 meters above the ground at a 3 meter anechoic chamber test site. The table was rotated 360 degrees to determine the position of the highest radiation.
2. During performing radiated emission below 1 GHz, the EUT was set 3 meters away from the interference receiving antenna, which was mounted on the top of a variable-height antenna tower. During performing radiated emission above 1 GHz, the EUT was set 3 meter away from the interference-receiving antenna.
3. The antenna is a broadband antenna, and its height is varied from one meter to four meters above the ground to determine the maximum value of the field strength. Both horizontal and vertical polarizations of the antenna are set to make the measurement.
4. For each suspected emission, the EUT was arranged to its worst case and then the antenna was tuned to heights from 1 meter to 4 meters and the table was turned from 0 degrees to 360 degrees to find the maximum reading.
5. The test-receiver system was set to Peak Detect Function and Specified Bandwidth with Maximum Hold Mode.
6. If the emission level of the EUT in peak mode was 10 dB lower than the limit specified, then testing could be stopped and the peak values of the EUT would be reported. Otherwise the emissions that did not have 10 dB margin would be re-tested one by one using peak, quasi-peak or average method as specified and then reported in a data sheet.

NOTE;

All data rates and modes were investigated for radiated spurious emissions. Only the radiated emissions of the configuration that produced the worst case emissions are reported in this section.

1. Unwanted Emissions into Non-Restricted Frequency Bands

- The Reference Level Measurement refer to section 9.1 & 10.1.1

Set analyzer center frequency, SPAN = 1.5 times the DTS channel bandwidth, the RBW = 3 kHz and VBW \geq 3 x RBW, Detector = Peak, Sweep time = Auto couple, Trace = Max hold (i.e., set = 100 kHz and VBW \geq 300 kHz)

- Unwanted Emissions Level Measurement refer to section 9.1 & 10.1.2

Set analyzer emission frequency, the RBW = 100 kHz and VBW \geq 300 kHz, Detector = Peak, Sweep time = Auto couple, Trace = Max hold

2. Unwanted Emissions into Restricted Frequency Bands

- Peak Power measurement procedure refer to section 8.1.1 & 10.2.3.2

Set RBW = 1 MHz, VBW \geq 3 x RBW, SPAN \geq RBW, Detector = Peak, Sweep time = Auto couple, Trace = Max hold

Note that if the peak measured value complies with the average limit, it is not necessary to perform a separate average measurement. If this option is exercised, it should be so noted in the test report.

-Average Power measurements procedure refer to section 8.2.1 & 10.2.3.3

Set the analyzer span to a minimum of 1.5 times the EBW, RBW = 1 MHz, VBW \geq 3 MHz,

Ensure that the number of measurement points in the sweep \geq 2 x span/RBW, Sweep time = auto peak,

Detector = power averaging (RMS) or sample detector when RMS not available,

Employ trace averaging in power averaging (RMS) mode over a minimum of 100 traces.

Note : If the analyzer does not have a band power function, sum the spectral levels (in linear power units) at 1 MHz intervals extending across the entire EBW.

3. To get a maximum emission level from the EUT, the EUT is manipulated through three orthogonal planes.

2.3.2. Test Procedures for Conducted Spurious Emissions

All data rates and modes were investigated for conducted spurious emissions. Only the conducted emissions of the configuration that produced the worst case emissions are reported in this section.

Per the guidance of KDB 558074, section 10.1.1 & 10.1.2, the reference level for out of band emissions is established from the plots of this section since the band edge emissions are measured with a RBW of 100 kHz. This reference level is then used as the limit in subsequent plots for out of band spurious emissions shown in section 2.4.3. The limit for out of band spurious emission at the band edge is 30 dB below the fundamental emission level measured in a 100 kHz bandwidth.

The results shown in this test report refer only to the sample(s) tested unless otherwise stated. This test report cannot be reproduced, except in full, without prior written permission of the Company.

2.4. Test Results

Ambient temperature : (23 ± 2) °C
 Relative humidity : 47 % R.H.

2.4.1. Radiated Spurious Emission (Worst case configuration_11b mode, 1 Mbps, middle channel)

The frequency spectrum from 30 MHz to 1 000 MHz was investigated. All reading values are peak values.

Radiated Emissions			Ant	Correction Factors		Total	FCC Limit	
Frequency (MHz)	Reading (dBµV)	Detect Mode	Pol.	AF (dB/m)	AMP + CL (dB)	Actual (dBµV/m)	Limit (dBµV/m)	Margin (dB)
33.9	40.1	Peak	H	12.0	-26.8	25.3	40.0	14.7
34.0	40.9	Peak	V	12.0	-26.8	26.1	40.0	13.9
130.6	36.7	Peak	H	8.8	-25.8	19.7	43.5	23.8
213.1	33.6	Peak	V	11.4	-25.1	19.9	43.5	23.6
327.4	35.1	Peak	H	12.9	-24.6	23.4	46.0	22.6
607.6	37.4	Peak	V	17.7	-25.1	30.0	46.0	16.0
Above 700.0	Not detected	-	-	-	-	-	-	-

Remark:

1. All spurious emission at channels are almost the same below 1 GHz, so that the middle channel was chosen at representative in final test.
2. Actual = Reading + AF + AMP + CL

The results shown in this test report refer only to the sample(s) tested unless otherwise stated. This test report cannot be reproduced, except in full, without prior written permission of the Company.

2.4.2. Spurious Radiated Emission

The frequency spectrum above 1 000 MHz was investigated. Emission levels are not reported much lower than the limits by over 30 dB.

DSSS : 802.11b(1 Mbps)

Low Channel (2 412 MHz)

Radiated Emissions			Ant	Correction Factors		Total	FCC Limit	
Frequency (MHz)	Reading (dB μ V)	Detect Mode	Pol.	AF (dB/m)	CL (dB)	Actual (dB μ V/m)	Limit (dB μ V/m)	Margin (dB)
*2 390.00	25.42	Peak	H	28.05	7.18	60.65	74.00	13.35
*2 390.00	14.77	Average	H	28.05	7.18	50.00	54.00	4.01

Radiated Emissions			Ant	Correction Factors		Total	FCC Limit	
Frequency (MHz)	Reading (dB μ V)	Detect Mode	Pol.	AF (dB/m)	AMP+CL (dB)	Actual (dB μ V/m)	Limit (dB μ V/m)	Margin (dB)
*4 824.15	41.82	Peak	V	32.31	-33.56	40.57	74.00	33.43
Above 4 900.00	Not detected	-	-	-	-	-	-	-

The results shown in this test report refer only to the sample(s) tested unless otherwise stated. This test report cannot be reproduced, except in full, without prior written permission of the Company.

Middle Channel (2 437 MHz)

Radiated Emissions			Ant	Correction Factors		Total	FCC Limit	
Frequency (MHz)	Reading (dB μ V)	Detect Mode	Pol.	AF (dB/m)	AMP+CL (dB)	Actual (dB μ V/m)	Limit (dB μ V/m)	Margin (dB)
*4 873.90	40.00	Peak	V	32.79	-33.50	39.29	74.00	34.71
Above 4 900.00	Not detected	-	-	-	-	-	-	-

High Channel (2 462 MHz)

Radiated Emissions			Ant	Correction Factors		Total	FCC Limit	
Frequency (MHz)	Reading (dB μ V)	Detect Mode	Pol.	AF (dB/m)	CL (dB)	Actual (dB μ V/m)	Limit (dB μ V/m)	Margin (dB)
*2 483.50	26.11	Peak	H	28.31	7.37	61.79	74.00	12.21
*2 483.50	14.58	Average	H	28.31	7.37	50.26	54.00	3.74

Radiated Emissions			Ant	Correction Factors		Total	FCC Limit	
Frequency (MHz)	Reading (dB μ V)	Detect Mode	Pol.	AF (dB/m)	AMP+CL (dB)	Actual (dB μ V/m)	Limit (dB μ V/m)	Margin (dB)
*4 924.10	40.87	Peak	V	33.10	-33.34	40.63	74.00	33.37
Above 5 000.00	Not detected	-	-	-	-	-	-	-

The results shown in this test report refer only to the sample(s) tested unless otherwise stated. This test report cannot be reproduced, except in full, without prior written permission of the Company.

OFDM : 802.11g(6 Mbps)

Low Channel (2 412 MHz)

Radiated Emissions			Ant	Correction Factors		Total	FCC Limit	
Frequency (MHz)	Reading (dB μ V)	Detect Mode	Pol.	AF (dB/m)	CL (dB)	Actual (dB μ V/m)	Limit (dB μ V/m)	Margin (dB)
*2 390.00	25.25	Peak	H	28.05	7.18	60.48	74.00	13.52
*2 390.00	14.82	Average	H	28.05	7.18	50.05	54.00	3.95

Radiated Emissions			Ant	Correction Factors		Total	FCC Limit	
Frequency (MHz)	Reading (dB μ V)	Detect Mode	Pol.	AF (dB/m)	AMP+CL (dB)	Actual (dB μ V/m)	Limit (dB μ V/m)	Margin (dB)
*4 848.30	41.45	Peak	V	32.59	-33.12	40.92	74.00	33.08
Above 4 900.00	Not detected	-	-	-	-	-	-	-

Middle Channel (2 437 MHz)

Radiated Emissions			Ant	Correction Factors		Total	FCC Limit	
Frequency (MHz)	Reading (dB μ V)	Detect Mode	Pol.	AF (dB/m)	AMP+CL (dB)	Actual (dB μ V/m)	Limit (dB μ V/m)	Margin (dB)
*4 850.45	39.83	Peak	V	32.60	-33.09	39.34	74.00	34.66
Above 4 900.00	Not detected	-	-	-	-	-	-	-

The results shown in this test report refer only to the sample(s) tested unless otherwise stated. This test report cannot be reproduced, except in full, without prior written permission of the Company.

High Channel (2 462 MHz)

Radiated Emissions			Ant	Correction Factors		Total	FCC Limit	
Frequency (MHz)	Reading (dB μ V)	Detect Mode	Pol.	AF (dB/m)	CL (dB)	Actual (dB μ V/m)	Limit (dB μ V/m)	Margin (dB)
*2 483.50	25.04	Peak	H	28.31	7.37	60.72	74.00	13.28
*2 483.50	15.09	Average	H	28.31	7.37	50.77	54.00	3.23

Radiated Emissions			Ant	Correction Factors		Total	FCC Limit	
Frequency (MHz)	Reading (dB μ V)	Detect Mode	Pol.	AF (dB/m)	AMP+CL (dB)	Actual (dB μ V/m)	Limit (dB μ V/m)	Margin (dB)
*4 930.00	40.88	Peak	V	33.16	-33.33	40.71	74.00	33.29
Above 5 000.00	Not detected	-	-	-	-	-	-	-

The results shown in this test report refer only to the sample(s) tested unless otherwise stated. This test report cannot be reproduced, except in full, without prior written permission of the Company.

OFDM : 802.11n_HT20(MCS0)

Low Channel (2 412 MHz)

Radiated Emissions			Ant	Correction Factors		Total	FCC Limit	
Frequency (MHz)	Reading (dB μ V)	Detect Mode	Pol.	AF (dB/m)	CL (dB)	Actual (dB μ V/m)	Limit (dB μ V/m)	Margin (dB)
*2 390.00	25.02	Peak	H	28.05	7.18	60.25	74.00	13.75
*2 390.00	14.65	Average	H	28.05	7.18	49.88	54.00	4.12

Radiated Emissions			Ant	Correction Factors		Total	FCC Limit	
Frequency (MHz)	Reading (dB μ V)	Detect Mode	Pol.	AF (dB/m)	AMP+CL (dB)	Actual (dB μ V/m)	Limit (dB μ V/m)	Margin (dB)
*4 839.55	40.63	Peak	V	32.52	-33.28	39.87	74.00	34.13
Above 4 900.00	Not detected	-	-	-	-	-	-	-

Middle Channel (2 437 MHz)

Radiated Emissions			Ant	Correction Factors		Total	FCC Limit	
Frequency (MHz)	Reading (dB μ V)	Detect Mode	Pol.	AF (dB/m)	AMP+CL (dB)	Actual (dB μ V/m)	Limit (dB μ V/m)	Margin (dB)
*4 856.30	41.19	Peak	V	32.64	-33.19	40.64	74.00	33.36
Above 4 900.00	Not detected	-	-	-	-	-	-	-

The results shown in this test report refer only to the sample(s) tested unless otherwise stated. This test report cannot be reproduced, except in full, without prior written permission of the Company.

High Channel (2 462 MHz)

Radiated Emissions			Ant	Correction Factors		Total	FCC Limit	
Frequency (MHz)	Reading (dB μ V)	Detect Mode	Pol.	AF (dB/m)	CL (dB)	Actual (dB μ V/m)	Limit (dB μ V/m)	Margin (dB)
*2 483.50	24.30	Peak	H	28.31	7.37	59.98	74.00	14.02
*2 483.50	14.76	Average	H	28.31	7.37	50.44	54.00	3.56

Radiated Emissions			Ant	Correction Factors		Total	FCC Limit	
Frequency (MHz)	Reading (dB μ V)	Detect Mode	Pol.	AF (dB/m)	AMP+CL (dB)	Actual (dB μ V/m)	Limit (dB μ V/m)	Margin (dB)
*4 927.65	40.75	Peak	V	33.14	-33.35	40.54	74.00	33.46
Above 5 000.00	Not detected	-	-	-	-	-	-	-

The results shown in this test report refer only to the sample(s) tested unless otherwise stated. This test report cannot be reproduced, except in full, without prior written permission of the Company.

802.11a (6 Mbps)

Low Channel (5 745 MHz)

Radiated Emissions			Ant	Correction Factors		Total	Limit	
Frequency (MHz)	Reading (dB uV)	Detect Mode	Pol.	AF (dB/m)	CL (dB)	Actual (dB uV/m)	Limit (dB uV/m)	Margin (dB)
5 743.75	45.57	Peak	H	34.16	11.65	91.38	-	-

Frequency (MHz)	Reading (dB uV)	Detect Mode	Pol.	AF (dB/m)	AMP+CL (dB)	Actual (dB uV/m)	Limit (dB uV/m)	Margin (dB)
*11 496.15	46.27	Peak	V	38.44	-28.33	56.38	74.00	17.62
*11 496.15	33.51	Average	V	38.44	-28.33	43.62	54.00	10.38
Above 11 500.00	Not detected	-	-	-	-	-	-	-

Middle Channel (5 785 MHz)

Radiated Emissions			Ant	Correction Factors		Total	Limit	
Frequency (MHz)	Reading (dB uV)	Detect Mode	Pol.	AF (dB/m)	CL (dB)	Actual (dB uV/m)	Limit (dB uV/m)	Margin (dB)
5 780.00	44.64	Peak	H	34.10	11.22	89.96	-	-

Frequency (MHz)	Reading (dB uV)	Detect Mode	Pol.	AF (dB/m)	AMP+CL (dB)	Actual (dB uV/m)	Limit (dB uV/m)	Margin (dB)
*11 576.25	51.73	Peak	V	38.41	-27.74	62.40	74.00	11.60
*11 576.25	38.68	Average	V	38.41	-27.74	49.35	54.00	4.65
Above 11 600.00	Not detected	-	-	-	-	-	-	-

The results shown in this test report refer only to the sample(s) tested unless otherwise stated. This test report cannot be reproduced, except in full, without prior written permission of the Company.

High Channel (5 825 MHz)

Radiated Emissions			Ant	Correction Factors		Total	Limit	
Frequency (MHz)	Reading (dB uV)	Detect Mode	Pol.	AF (dB/m)	CL (dB)	Actual (dB uV/m)	Limit (dB uV/m)	Margin (dB)
5 818.75	44.90	Peak	H	34.10	10.82	89.82	-	-

Frequency (MHz)	Reading (dB uV)	Detect Mode	Pol.	AF (dB/m)	AMP+CL (dB)	Actual (dB uV/m)	Limit (dB uV/m)	Margin (dB)
*11 650.25	50.15	Peak	V	38.36	-27.32	61.19	74.00	12.81
*11 650.25	38.46	Average	V	38.36	-27.32	49.50	54.00	4.50
Above 11 700.00	Not detected	-	-	-	-	-	-	-

The results shown in this test report refer only to the sample(s) tested unless otherwise stated. This test report cannot be reproduced, except in full, without prior written permission of the Company.

802.11n-HT20 (MCS0)

Low Channel (5 745 MHz)

Radiated Emissions			Ant	Correction Factors		Total	Limit	
Frequency (MHz)	Reading (dB uV)	Detect Mode	Pol.	AF (dB/m)	CL (dB)	Actual (dB uV/m)	Limit (dB uV/m)	Margin (dB)
5 747.55	44.42	Peak	H	34.15	11.76	90.33	-	-

Frequency (MHz)	Reading (dB uV)	Detect Mode	Pol.	AF (dB/m)	AMP+CL (dB)	Actual (dB uV/m)	Limit (dB uV/m)	Margin (dB)
*11 498.75	44.30	Peak	V	38.46	-28.34	54.42	74.00	19.58
*11 498.75	32.96	Average	V	38.46	-28.34	43.08	54.00	10.92
Above 11 500.00	Not detected	-	-	-	-	-	-	-

Middle Channel (5 785 MHz)

Radiated Emissions			Ant	Correction Factors		Total	Limit	
Frequency (MHz)	Reading (dB uV)	Detect Mode	Pol.	AF (dB/m)	CL (dB)	Actual (dB uV/m)	Limit (dB uV/m)	Margin (dB)
5 783.75	45.28	Peak	H	34.08	11.15	90.51	-	-

Frequency (MHz)	Reading (dB uV)	Detect Mode	Pol.	AF (dB/m)	AMP+CL (dB)	Actual (dB uV/m)	Limit (dB uV/m)	Margin (dB)
*11 570.45	51.85	Peak	V	38.42	-27.79	62.48	74.00	11.52
*11 570.45	37.97	Average	V	38.42	-27.79	48.60	54.00	5.40
Above 11 600.00	Not detected	-	-	-	-	-	-	-

The results shown in this test report refer only to the sample(s) tested unless otherwise stated. This test report cannot be reproduced, except in full, without prior written permission of the Company.

High Channel (5 825 MHz)

Radiated Emissions			Ant	Correction Factors		Total	Limit	
Frequency (MHz)	Reading (dB uV)	Detect Mode	Pol.	AF (dB/m)	CL (dB)	Actual (dB uV/m)	Limit (dB uV/m)	Margin (dB)
5 823.70	45.42	Peak	H	34.10	10.82	90.34	-	-

Frequency (MHz)	Reading (dB uV)	Detect Mode	Pol.	AF (dB/m)	AMP+CL (dB)	Actual (dB uV/m)	Limit (dB uV/m)	Margin (dB)
*11 651.25	50.71	Peak	V	38.36	-27.32	61.75	74.00	12.25
*11 651.25	37.46	Average	V	38.36	-27.32	48.50	54.00	5.50
Above 11 700.00	Not detected	-	-	-	-	-	-	-

The results shown in this test report refer only to the sample(s) tested unless otherwise stated. This test report cannot be reproduced, except in full, without prior written permission of the Company.

802.11n_HT40(MCS0)

Low Channel (5 755 MHz)

Radiated Emissions			Ant	Correction Factors		Total	Limit	
Frequency (MHz)	Reading (dB uV)	Detect Mode	Pol.	AF (dB/m)	CL (dB)	Actual (dB uV/m)	Limit (dB uV/m)	Margin (dB)
5 752.55	42.04	Peak	H	34.12	11.78	87.94	-	-
Frequency (MHz)	Reading (dB uV)	Detect Mode	Pol.	AF (dB/m)	AMP+CL (dB)	Actual (dB uV/m)	Limit (dB uV/m)	Margin (dB)
*11 517.50	42.53	Peak	V	38.47	-28.20	52.80	74.00	21.20
*11 517.50	29.72	Average	V	38.47	-28.20	39.99	54.00	14.01
Above 11 600.00	Not detected	-	-	-	-	-	-	-

High Channel (5 795 MHz)

Radiated Emissions			Ant	Correction Factors		Total	Limit	
Frequency (MHz)	Reading (dB uV)	Detect Mode	Pol.	AF (dB/m)	CL (dB)	Actual (dB uV/m)	Limit (dB uV/m)	Margin (dB)
5 798.75	40.74	Peak	H	34.02	10.85	85.61	-	-
Frequency (MHz)	Reading (dB uV)	Detect Mode	Pol.	AF (dB/m)	AMP+CL (dB)	Actual (dB uV/m)	Limit (dB uV/m)	Margin (dB)
*11 597.50	46.10	Peak	V	38.40	-27.57	56.93	74.00	17.07
*11 597.50	32.96	Average	V	38.40	-27.57	43.79	54.00	10.21
Above 11 600.00	Not detected	-	-	-	-	-	-	-

Remarks :

1. "*" means the restricted band.
2. Measuring frequencies from 1 GHz to the 10th harmonic of highest fundamental Frequency.
3. Radiated emissions measured in frequency above 1 000 MHz were made with an instrument using peak/average detector mode.
4. Average test would be performed if the peak result were greater than the average limit.
5. Actual = Reading + AF + AMP + CL

The results shown in this test report refer only to the sample(s) tested unless otherwise stated. This test report cannot be reproduced, except in full, without prior written permission of the Company.

2.4.3. Spurious RF Conducted Emissions: Plot of Spurious RF Conducted Emission

DSSS : 802.11b(1 Mbps)

Low Channel

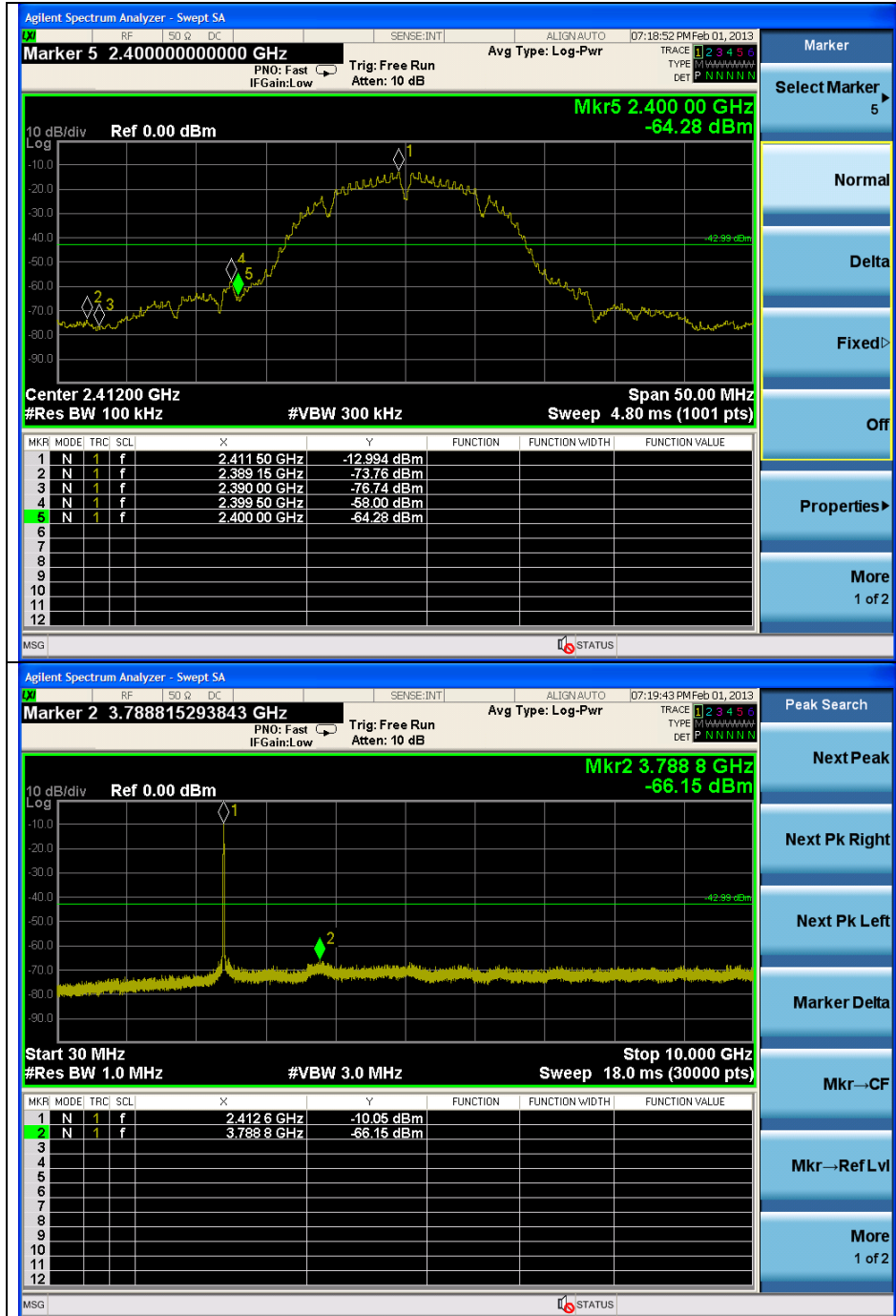

The results shown in this test report refer only to the sample(s) tested unless otherwise stated. This test report cannot be reproduced, except in full, without prior written permission of the Company.

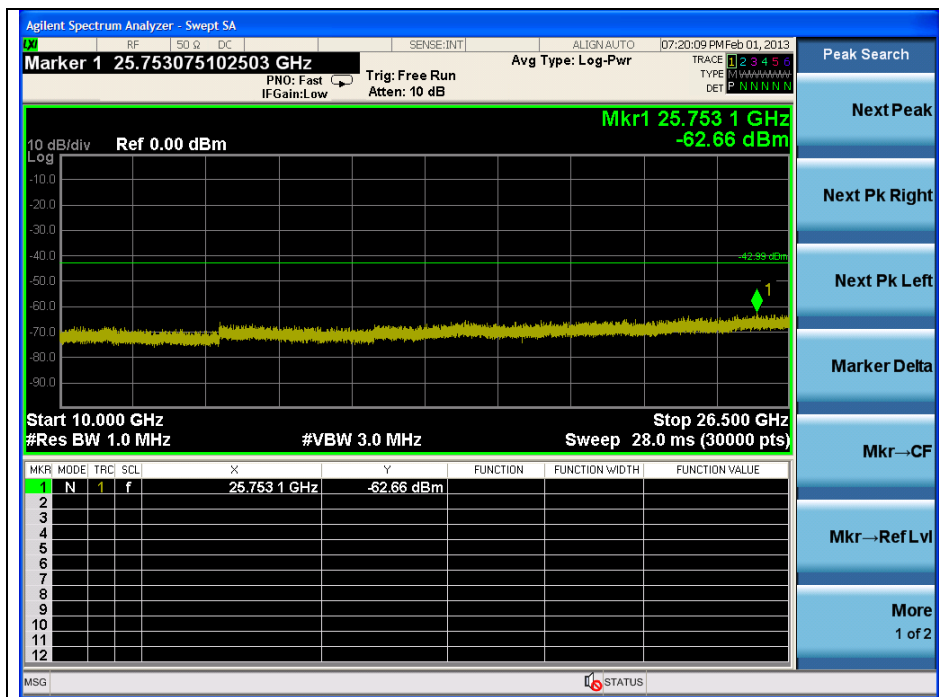

Note:

Offset (dB) = Attenuator(dB) + Cable loss (dB)

Result (dB m) = Spurious offset (dB) + Reading values (dB m)

Frequency (MHz)	Reading values (dB m)	Spurious offset (dB)	Result (dB m)
2 389.15	-73.76	20.82	-52.94
2 390.00	-76.74	20.85	-55.89
2 399.50	-58.00	20.85	-37.15
2 400.00	-64.28	20.84	-43.44
3 788.80	Noise floor	-	-
25 753.10	Noise floor	-	-

The results shown in this test report refer only to the sample(s) tested unless otherwise stated. This test report cannot be reproduced, except in full, without prior written permission of the Company.

Middle Channel



The results shown in this test report refer only to the sample(s) tested unless otherwise stated. This test report cannot be reproduced, except in full, without prior written permission of the Company.

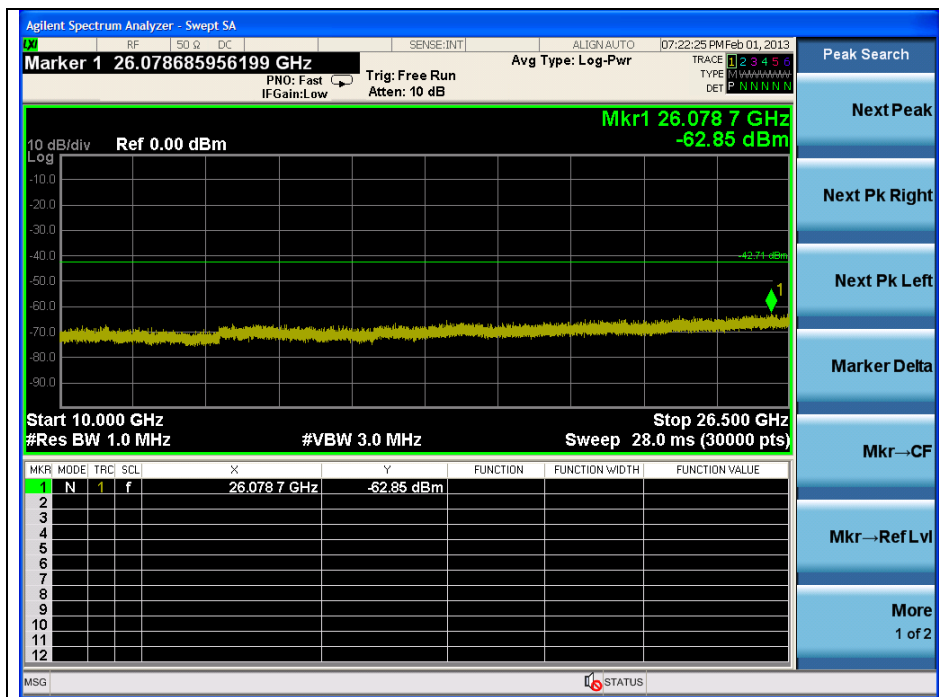

Note:

Offset (dB) = Attenuator(dB) + Cable loss (dB)

Result (dB m) = Spurious offset (dB) + Reading values (dB m)

Frequency (MHz)	Reading values (dB m)	Spurious offset (dB)	Result (dB m)
3 851.30	Noise floor	-	-
26 078.70	Noise floor	-	-

The results shown in this test report refer only to the sample(s) tested unless otherwise stated. This test report cannot be reproduced, except in full, without prior written permission of the Company.

High Channel

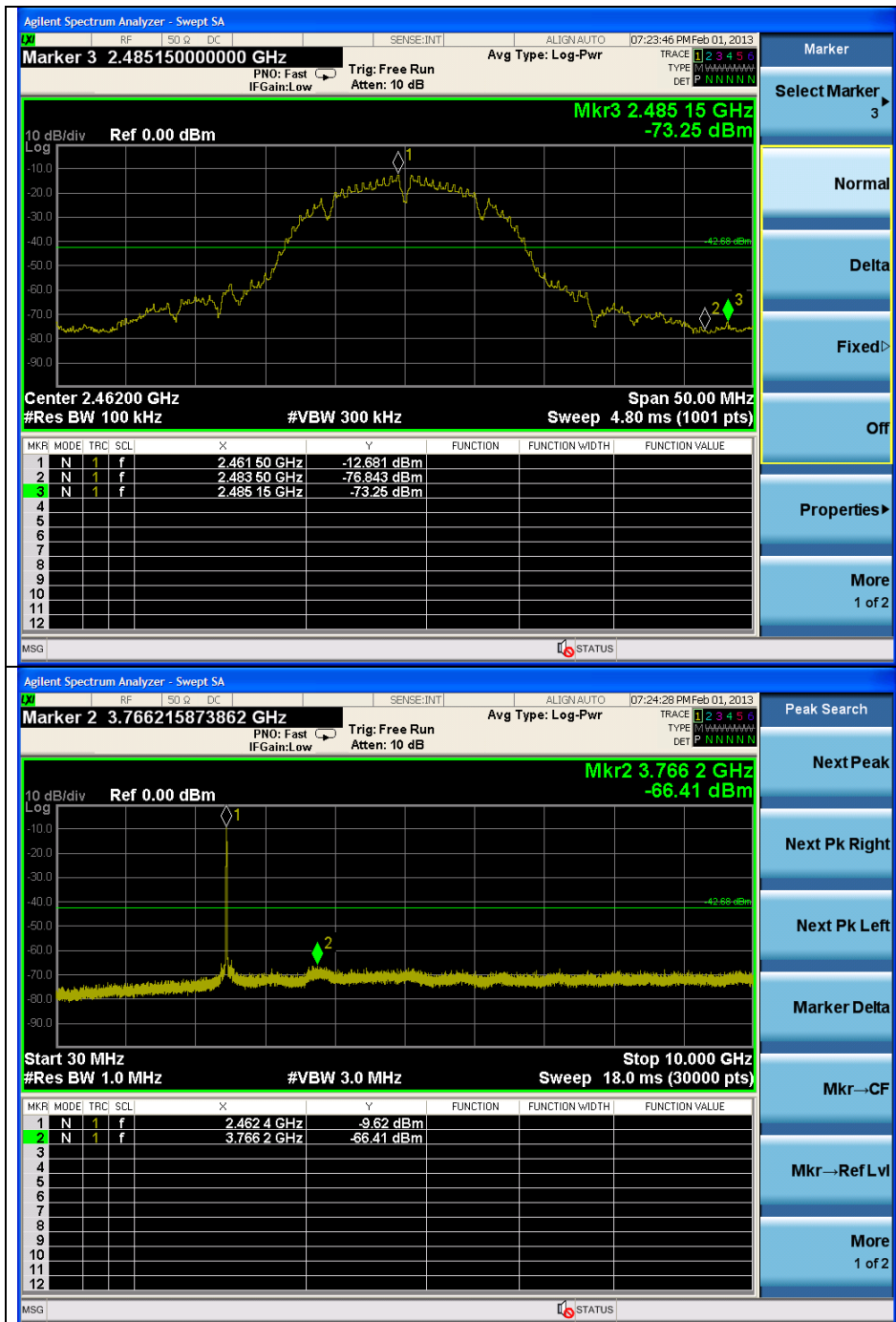

The results shown in this test report refer only to the sample(s) tested unless otherwise stated. This test report cannot be reproduced, except in full, without prior written permission of the Company.

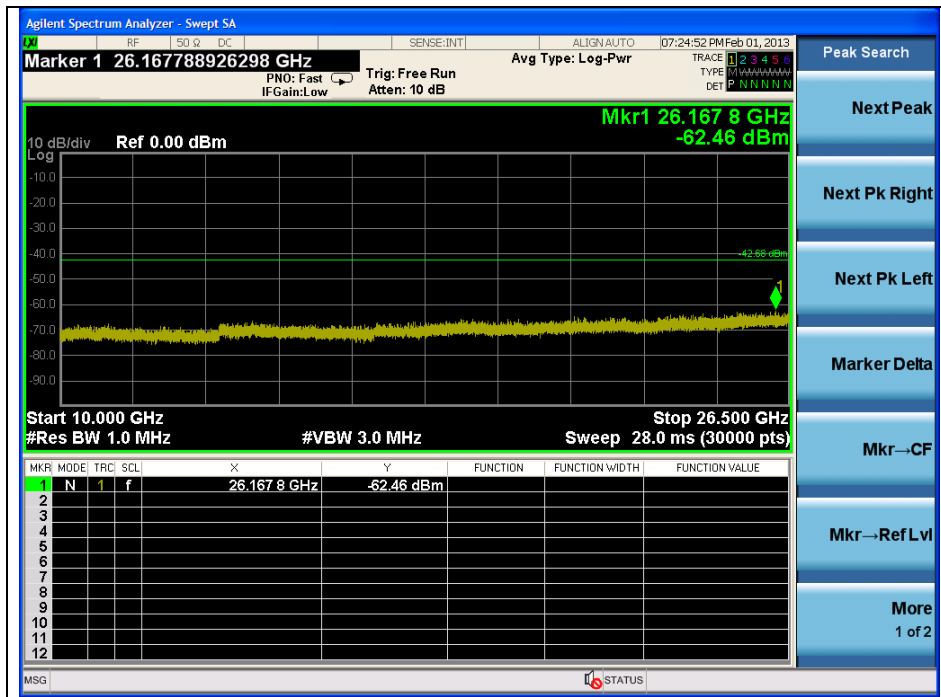

Note:

Offset (dB) = Attenuator(dB) + Cable loss (dB)

Result (dB m) = Spurious offset (dB) + Reading values (dB m)

Frequency (MHz)	Reading values (dB m)	Spurious offset (dB)	Result (dB m)
2 483.50	-76.84	20.79	-56.05
2 485.15	-73.25	20.74	-52.51
3 766.20	Noise floor	-	-
26 167.80	Noise floor	-	-

The results shown in this test report refer only to the sample(s) tested unless otherwise stated. This test report cannot be reproduced, except in full, without prior written permission of the Company.

OFDM : 802.11g(6 Mbps)
Low Channel

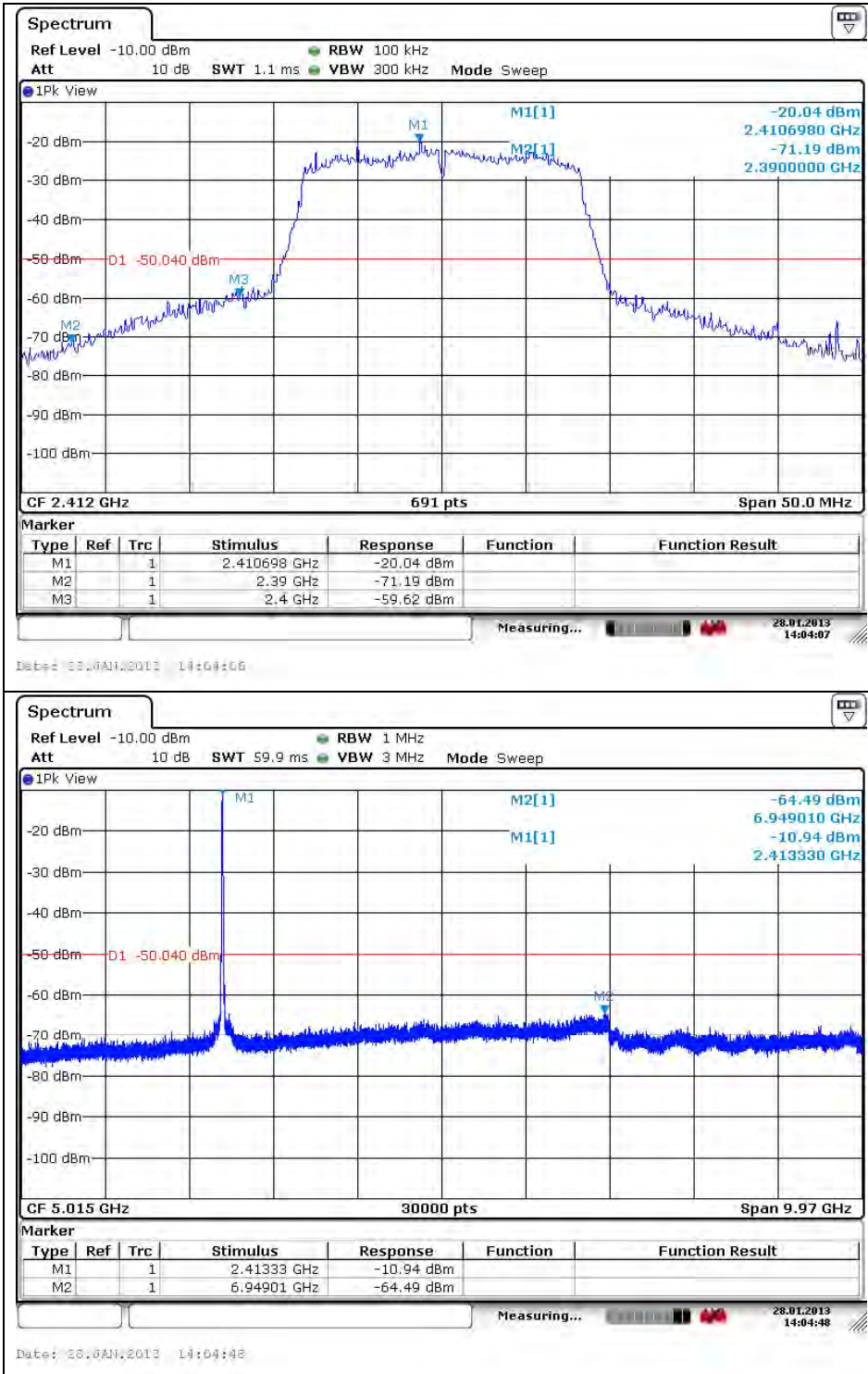

The results shown in this test report refer only to the sample(s) tested unless otherwise stated. This test report cannot be reproduced, except in full, without prior written permission of the Company.

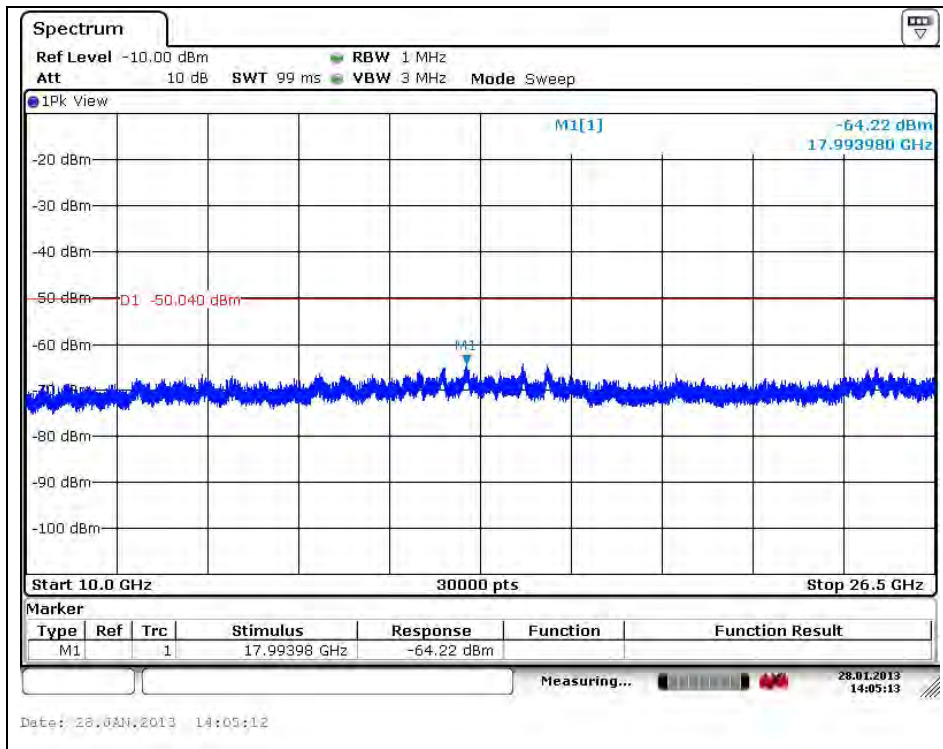

Note:

Offset (dB) = Attenuator(dB) + Cable loss (dB)

Result (dB m) = Spurious offset (dB) + Reading values (dB m)

Frequency (MHz)	Reading values (dB m)	Spurious offset (dB)	Result (dB m)
2 390.00	-71.19	20.85	-50.34
2 400.00	-59.62	20.84	-38.78
6 979.01	Noise floor	-	-
17 993.98	Noise floor	-	-

The results shown in this test report refer only to the sample(s) tested unless otherwise stated. This test report cannot be reproduced, except in full, without prior written permission of the Company.

Middle Channel

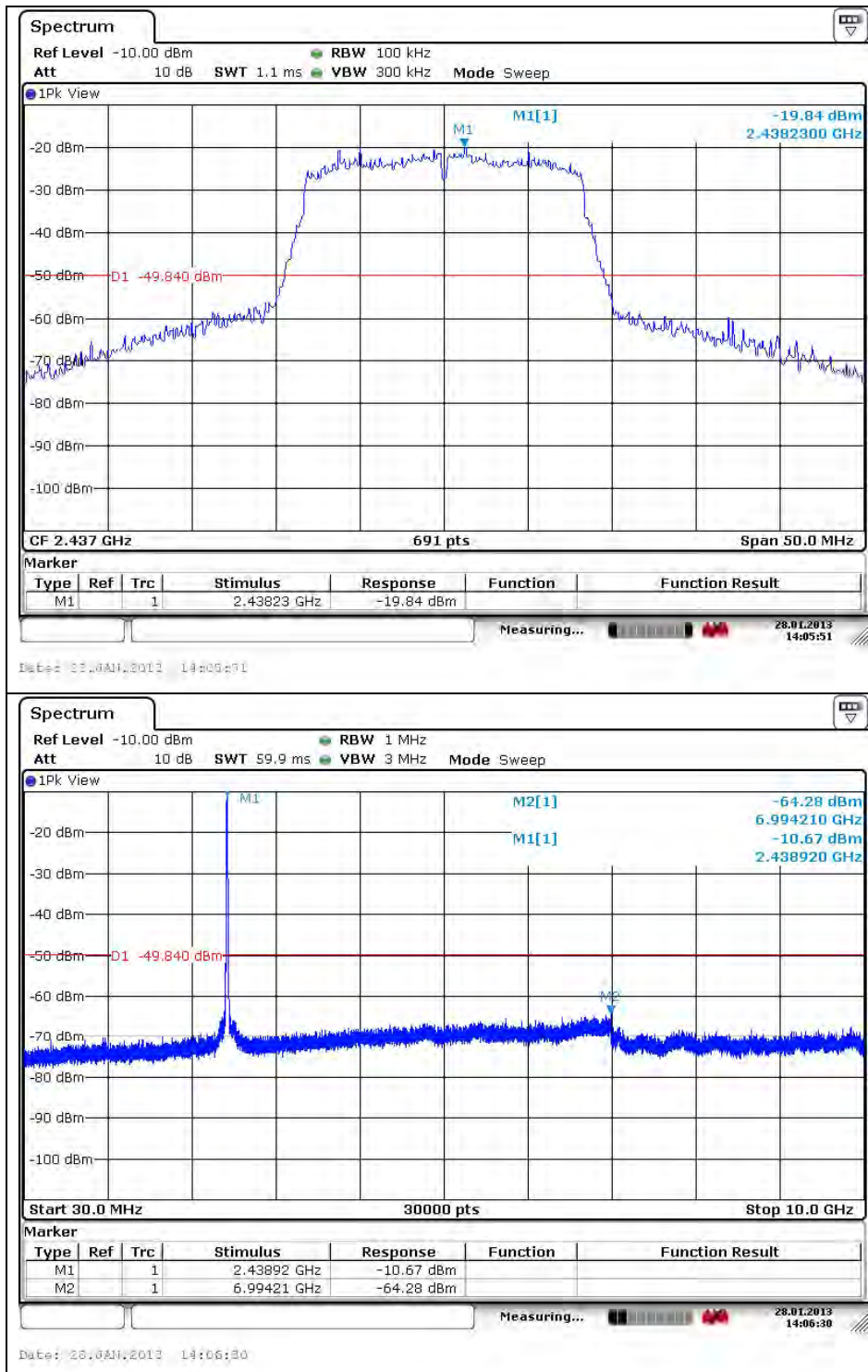

The results shown in this test report refer only to the sample(s) tested unless otherwise stated. This test report cannot be reproduced, except in full, without prior written permission of the Company.

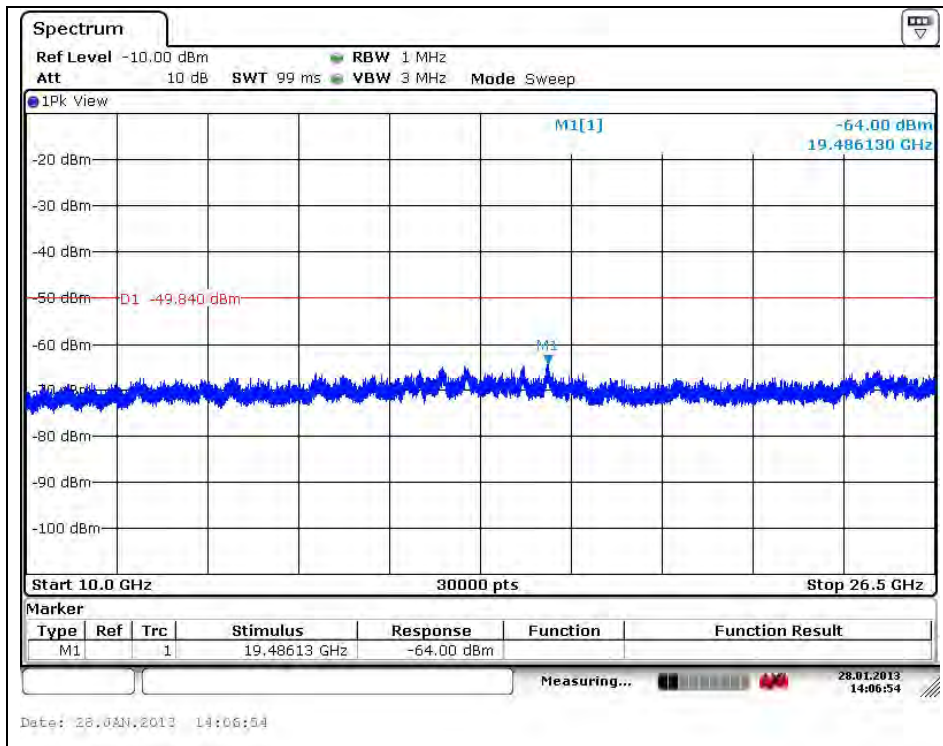

Note:

Offset (dB) = Attenuator(dB) + Cable loss (dB)

Result (dB m) = Spurious offset (dB) + Reading values (dB m)

Frequency (MHz)	Reading values (dB m)	Spurious offset (dB)	Result (dB m)
6 994.21	Noise floor	-	-
19 486.13	Noise floor	-	-

The results shown in this test report refer only to the sample(s) tested unless otherwise stated. This test report cannot be reproduced, except in full, without prior written permission of the Company.

High Channel

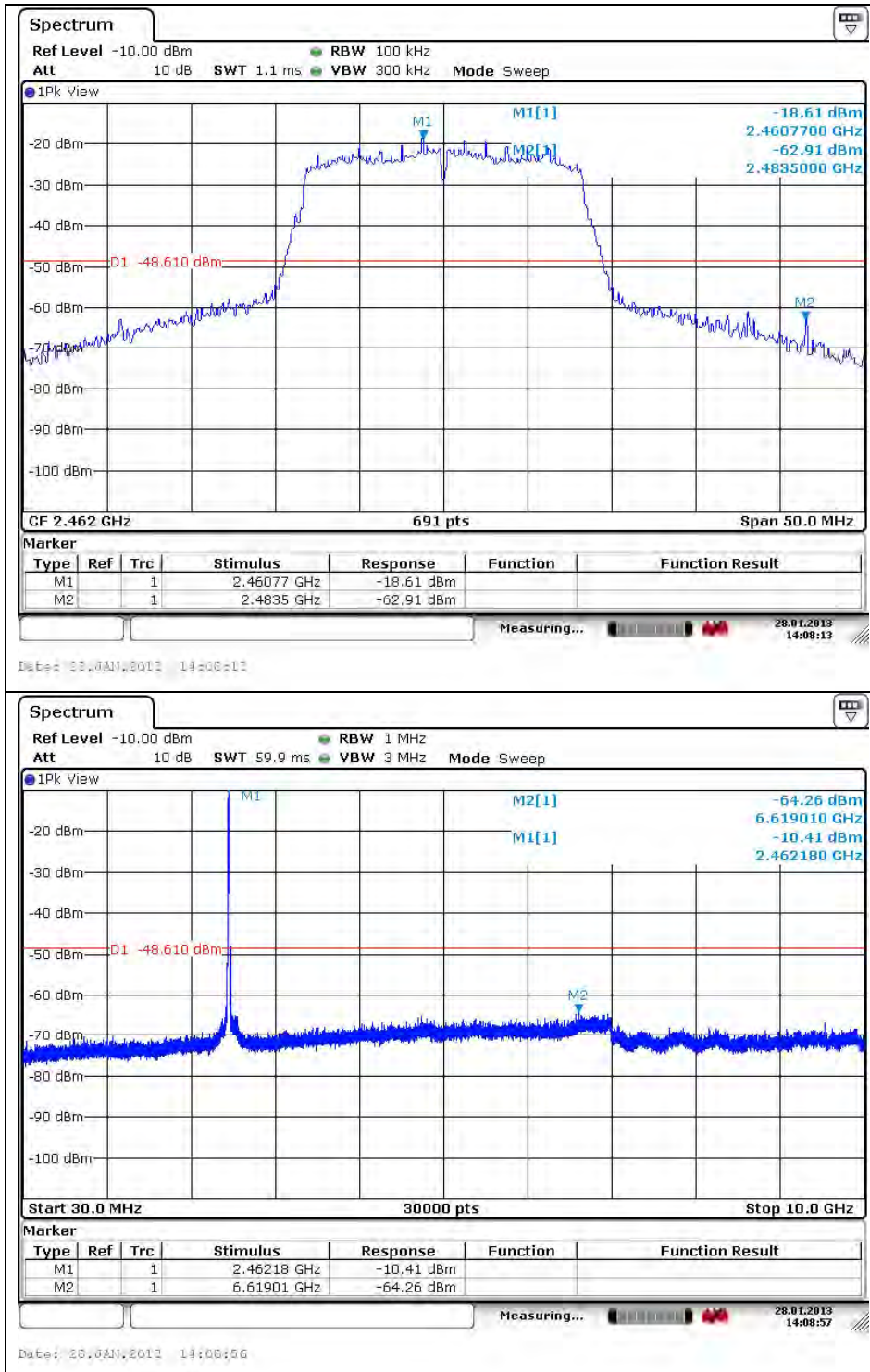

The results shown in this test report refer only to the sample(s) tested unless otherwise stated. This test report cannot be reproduced, except in full, without prior written permission of the Company.

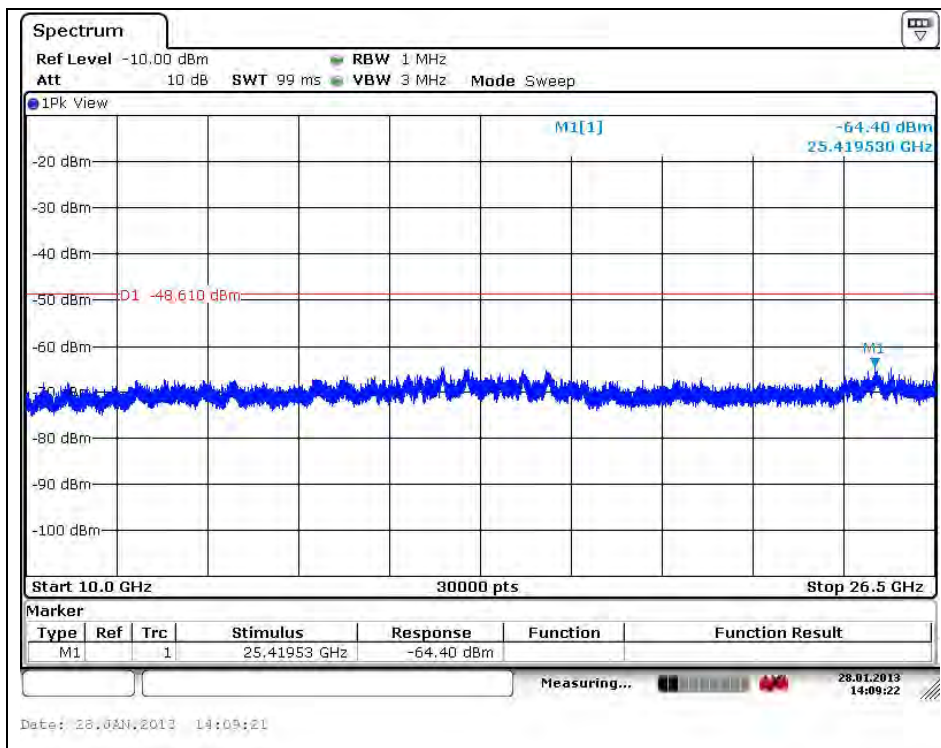

Note:

Offset (dB) = Attenuator(dB) + Cable loss (dB)

Result (dB m) = Spurious offset (dB) + Reading values (dB m)

Frequency (MHz)	Reading values (dB m)	Spurious offset (dB)	Result (dB m)
2 483.50	-62.91	20.79	-42.12
6 619.01	Noise floor	-	-
25 419.53	Noise floor	-	-

The results shown in this test report refer only to the sample(s) tested unless otherwise stated. This test report cannot be reproduced, except in full, without prior written permission of the Company.

OFDM : 802.11n_HT20(MCS0)
Low Channel

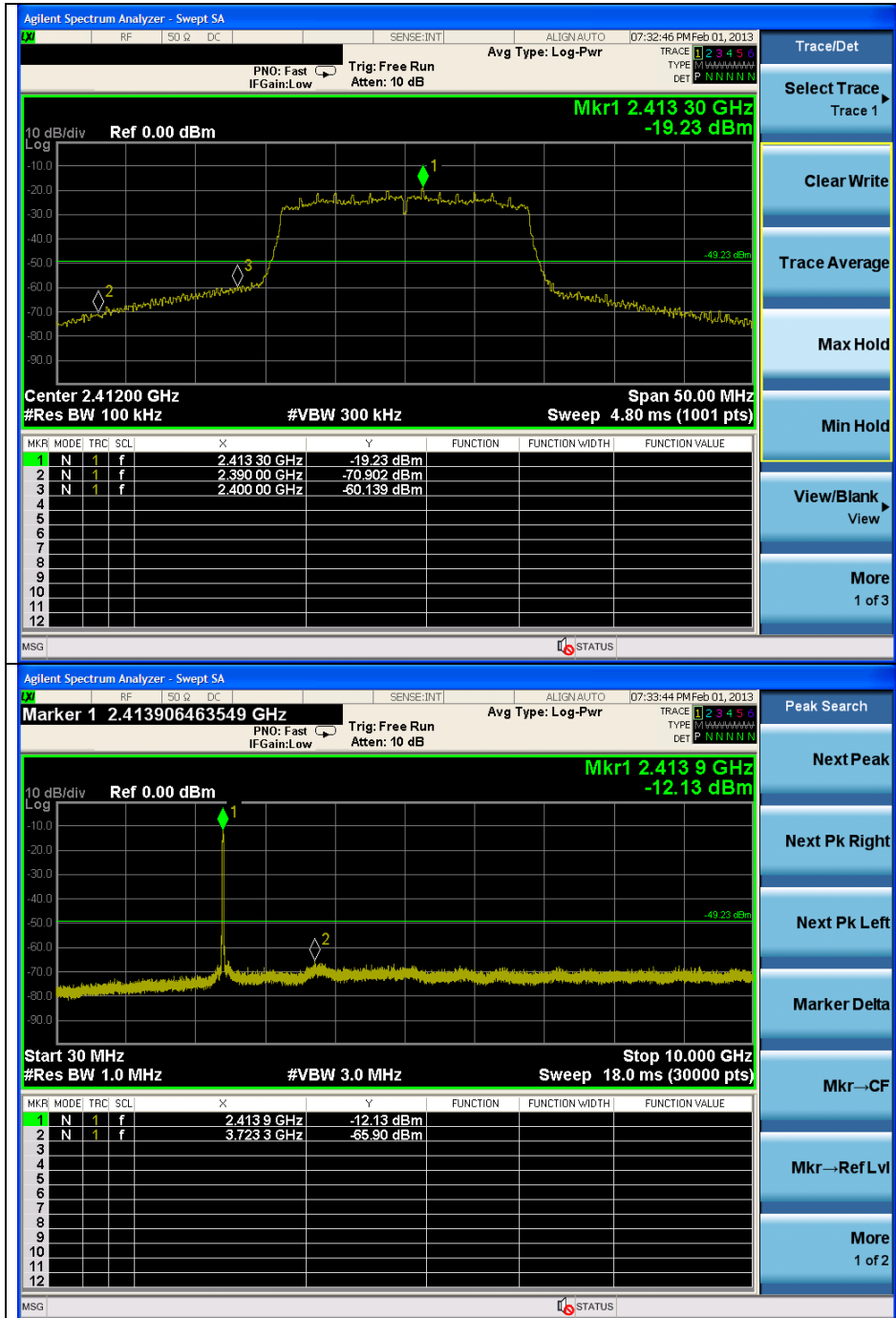

The results shown in this test report refer only to the sample(s) tested unless otherwise stated. This test report cannot be reproduced, except in full, without prior written permission of the Company.

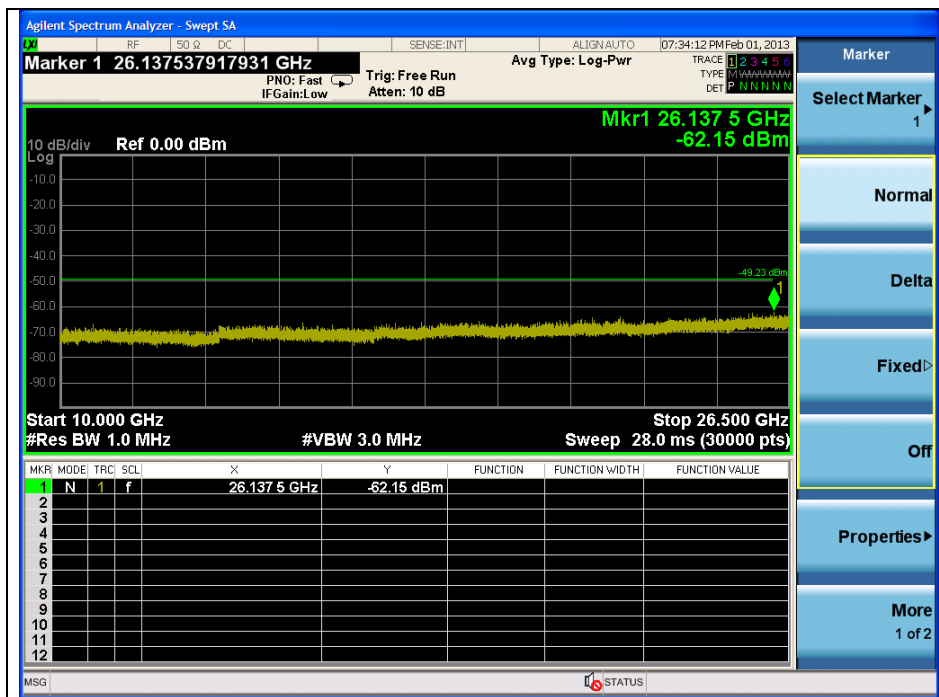

Note:

Offset (dB) = Attenuator(dB) + Cable loss (dB)

Result (dB m) = Spurious offset (dB) + Reading values (dB m)

Frequency (MHz)	Reading values (dB m)	Spurious offset (dB)	Result (dB m)
2 390.00	-70.90	20.85	-50.05
2 400.00	-60.14	20.84	-39.30
3 723.30	Noise floor	-	-
26 137.50	Noise floor	-	-

The results shown in this test report refer only to the sample(s) tested unless otherwise stated. This test report cannot be reproduced, except in full, without prior written permission of the Company.

Middle Channel

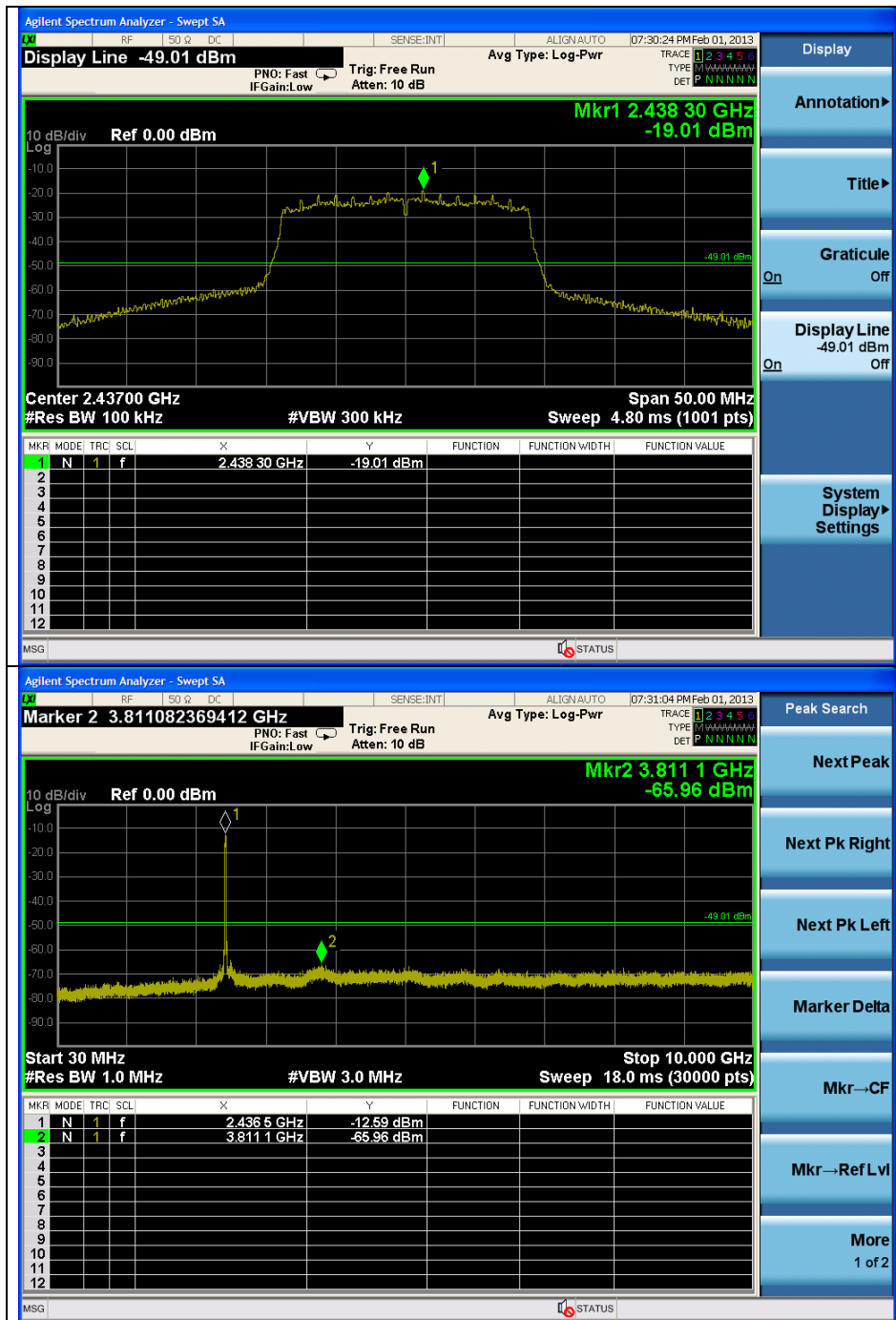

The results shown in this test report refer only to the sample(s) tested unless otherwise stated. This test report cannot be reproduced, except in full, without prior written permission of the Company.

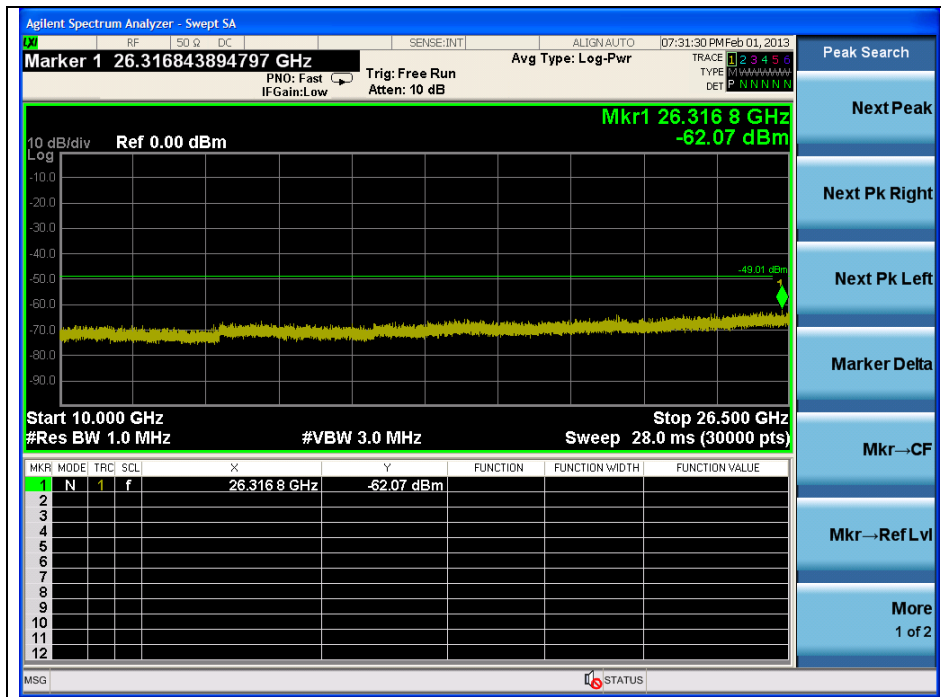

Note:

Offset (dB) = Attenuator(dB) + Cable loss (dB)

Result (dB m) = Spurious offset (dB) + Reading values (dB m)

Frequency (MHz)	Reading values (dB m)	Spurious offset (dB)	Result (dB m)
3 811.10	Noise floor	-	-
26 316.80	Noise floor	-	-

The results shown in this test report refer only to the sample(s) tested unless otherwise stated. This test report cannot be reproduced, except in full, without prior written permission of the Company.

High Channel

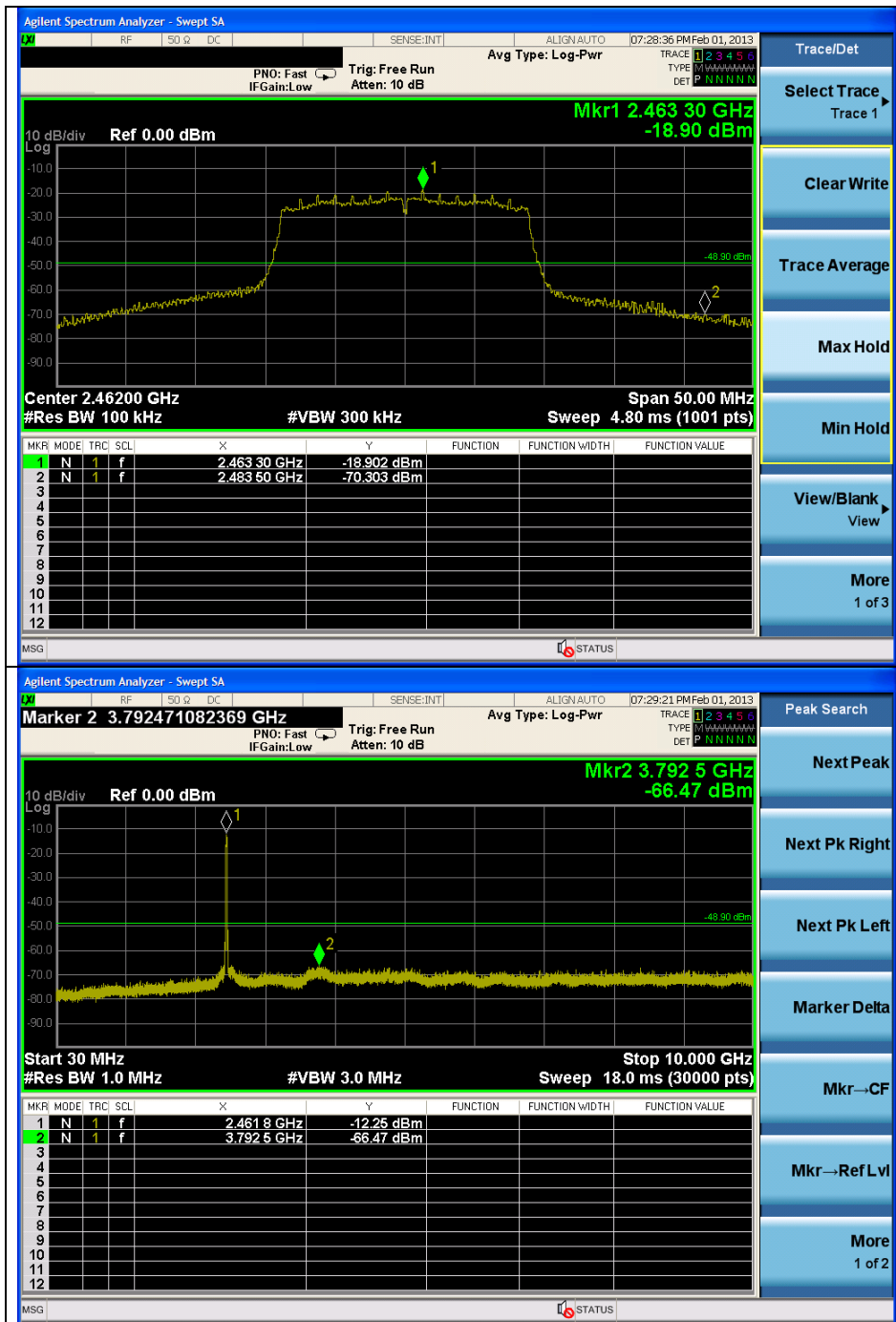

The results shown in this test report refer only to the sample(s) tested unless otherwise stated. This test report cannot be reproduced, except in full, without prior written permission of the Company.

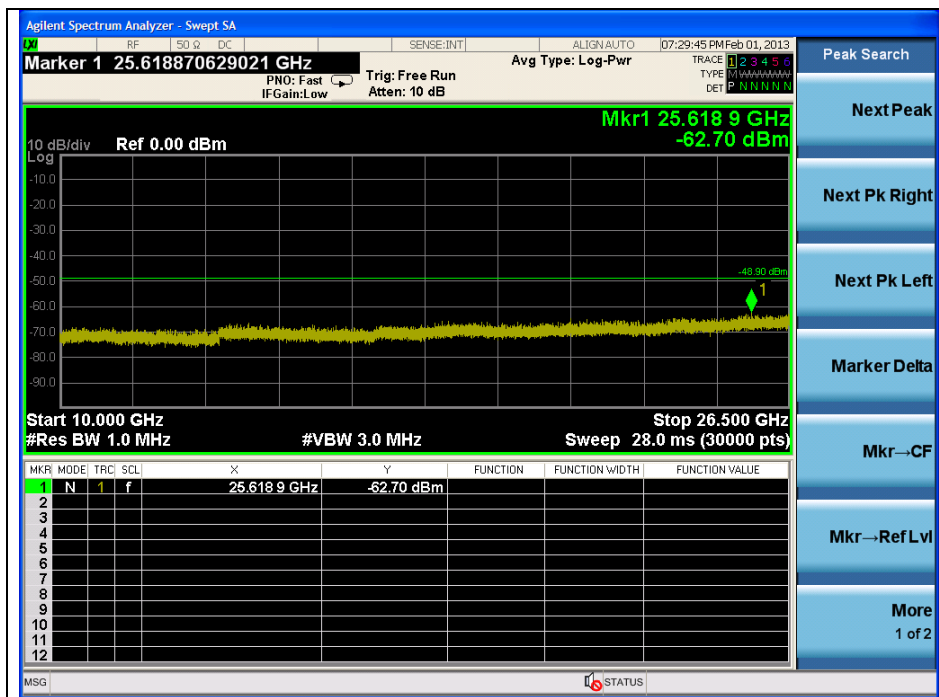

Note:

Offset (dB) = Attenuator(dB) + Cable loss (dB)

Result (dB m) = Spurious offset (dB) + Reading values (dB m)

Frequency (MHz)	Reading values (dB m)	Spurious offset (dB)	Result (dB m)
2 483.50	-70.30	20.79	-49.51
3 792.50	Noise floor	-	-
25 618.90	Noise floor	-	-

The results shown in this test report refer only to the sample(s) tested unless otherwise stated. This test report cannot be reproduced, except in full, without prior written permission of the Company.

5 800 Mhz

OFDM : 802.11a (6 Mbps)

Low Channel

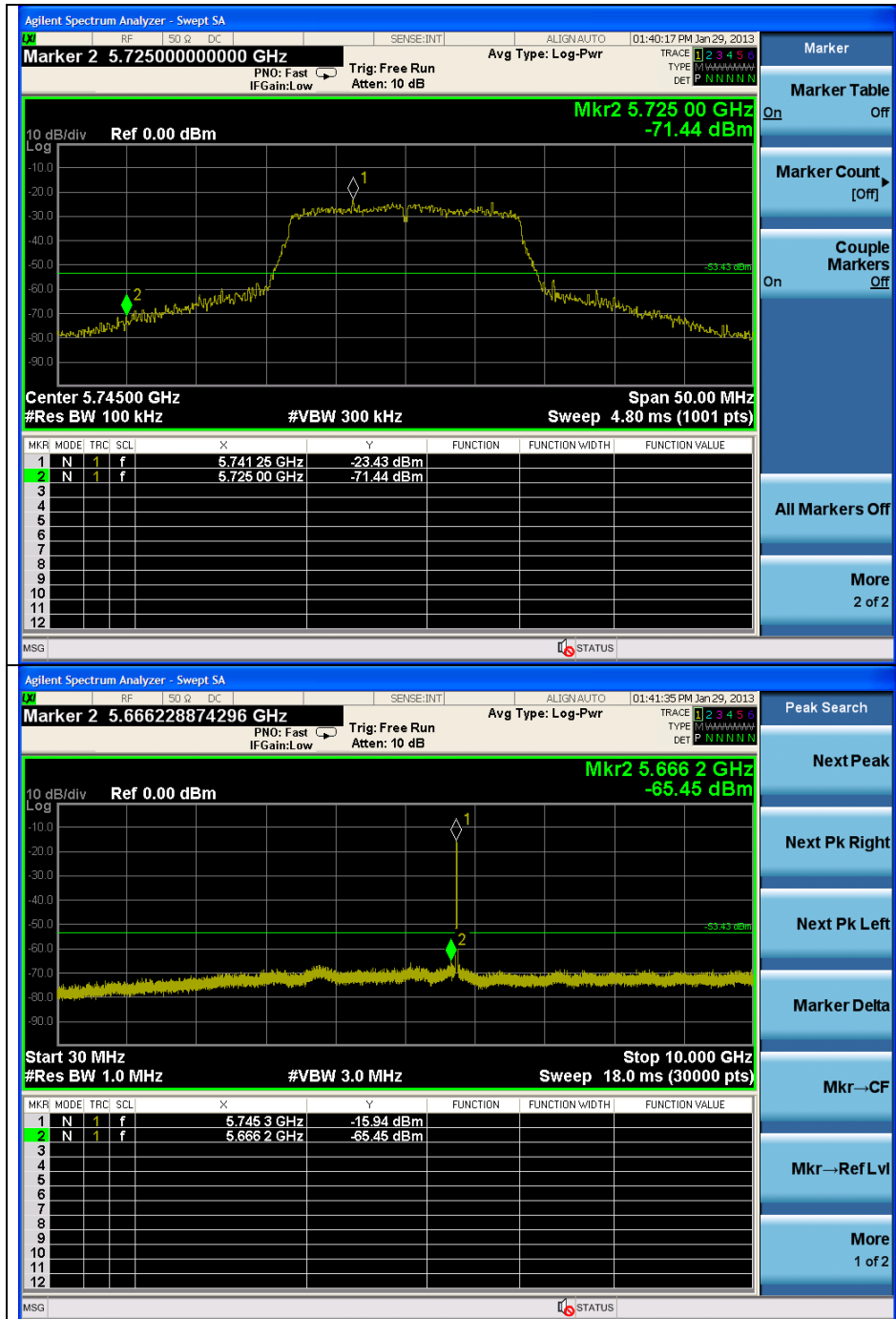

The results shown in this test report refer only to the sample(s) tested unless otherwise stated. This test report cannot be reproduced, except in full, without prior written permission of the Company.

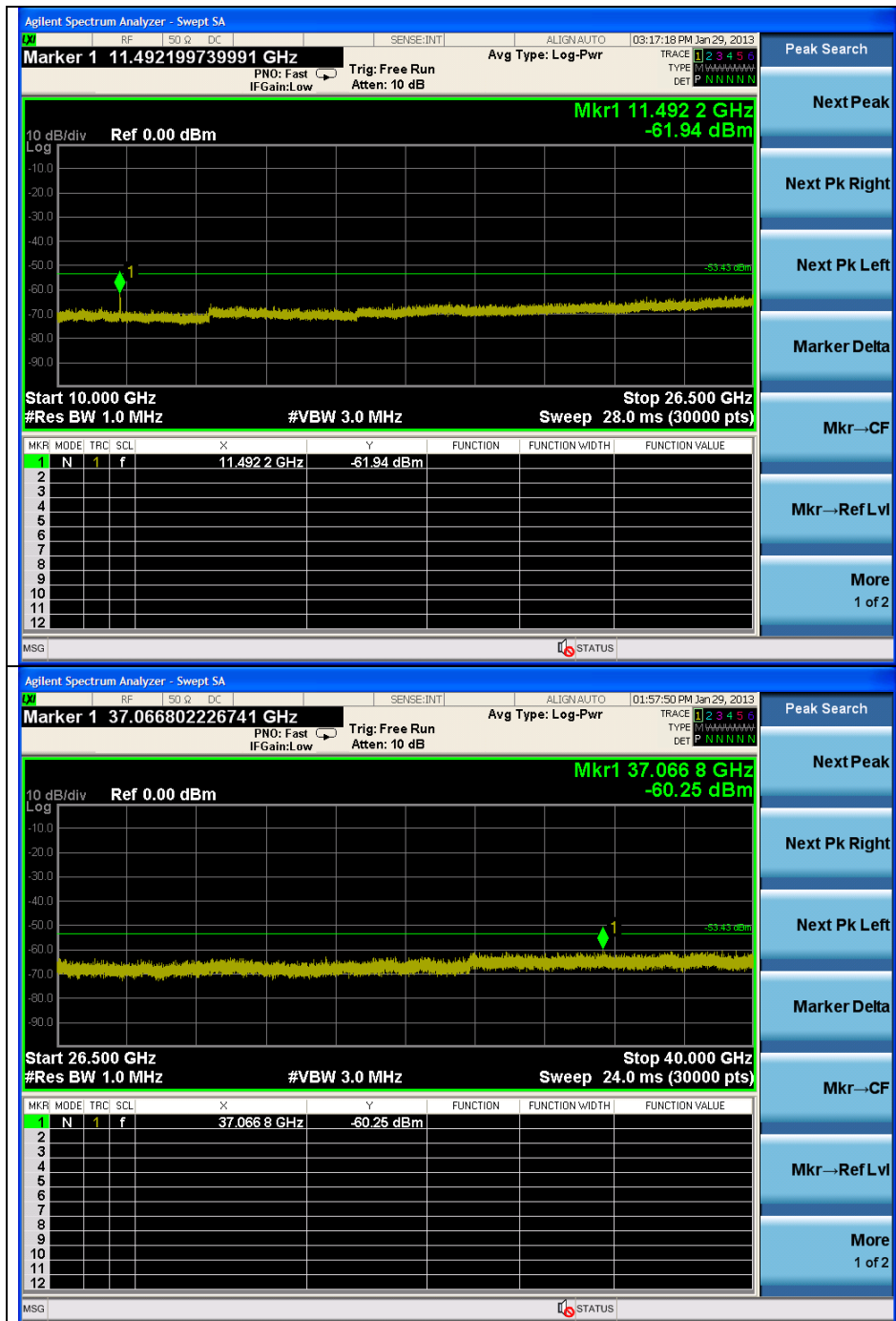

Note:

Offset (dB) = Attenuator(dB) + Cable loss (dB)

Result (dB m) = Spurious offset (dB) + Reading values (dB m)

Frequency (MHz)	Reading values (dB m)	Spurious offset (dB)	Result (dB m)
5 666.20	Noise floor	-	-
5 725.00	-71.44	20.70	-50.74
11 492.20	-61.94	23.22	-38.72
37 066.80	Noise floor	-	-

The results shown in this test report refer only to the sample(s) tested unless otherwise stated. This test report cannot be reproduced, except in full, without prior written permission of the Company.

Middle Channel

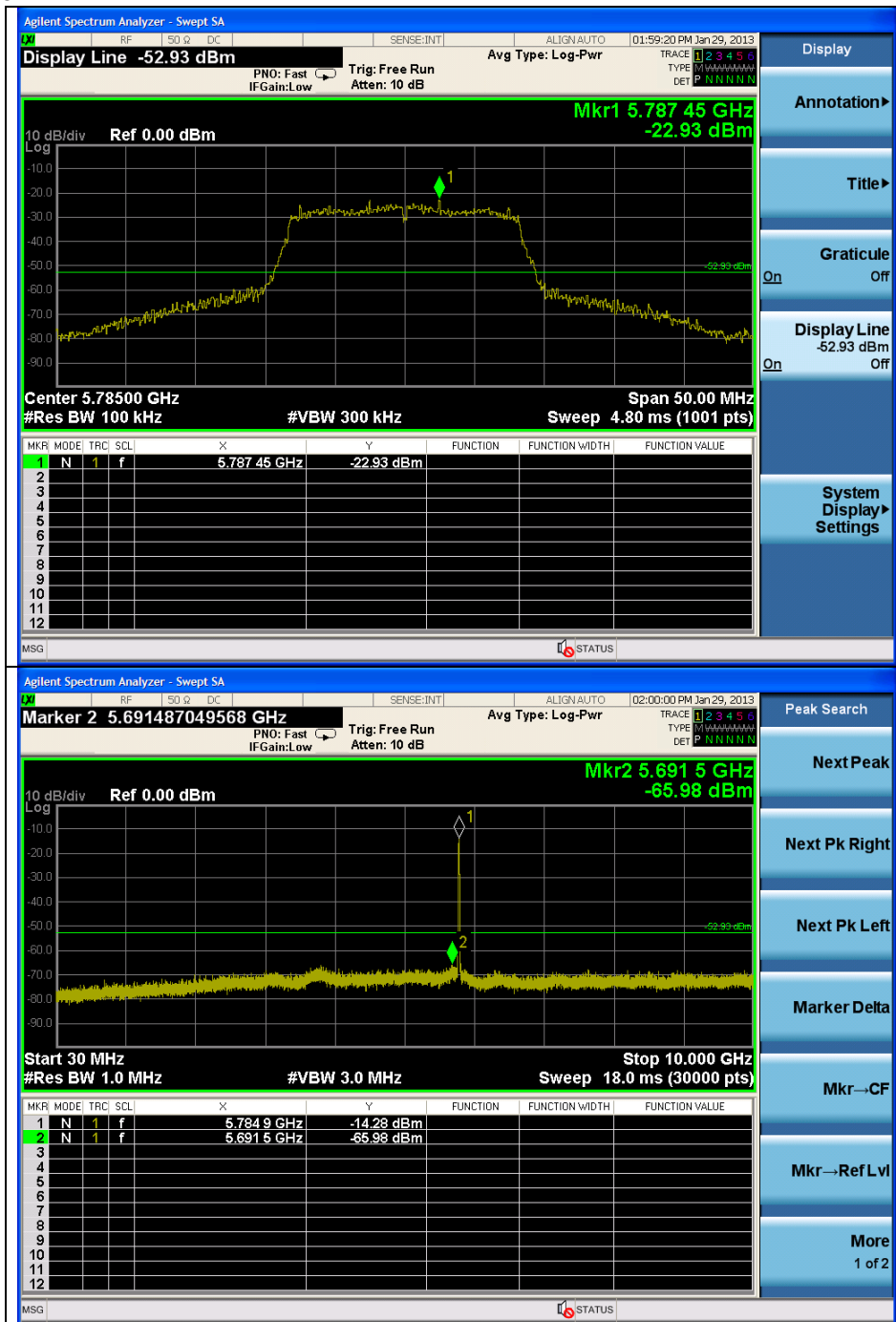

The results shown in this test report refer only to the sample(s) tested unless otherwise stated. This test report cannot be reproduced, except in full, without prior written permission of the Company.

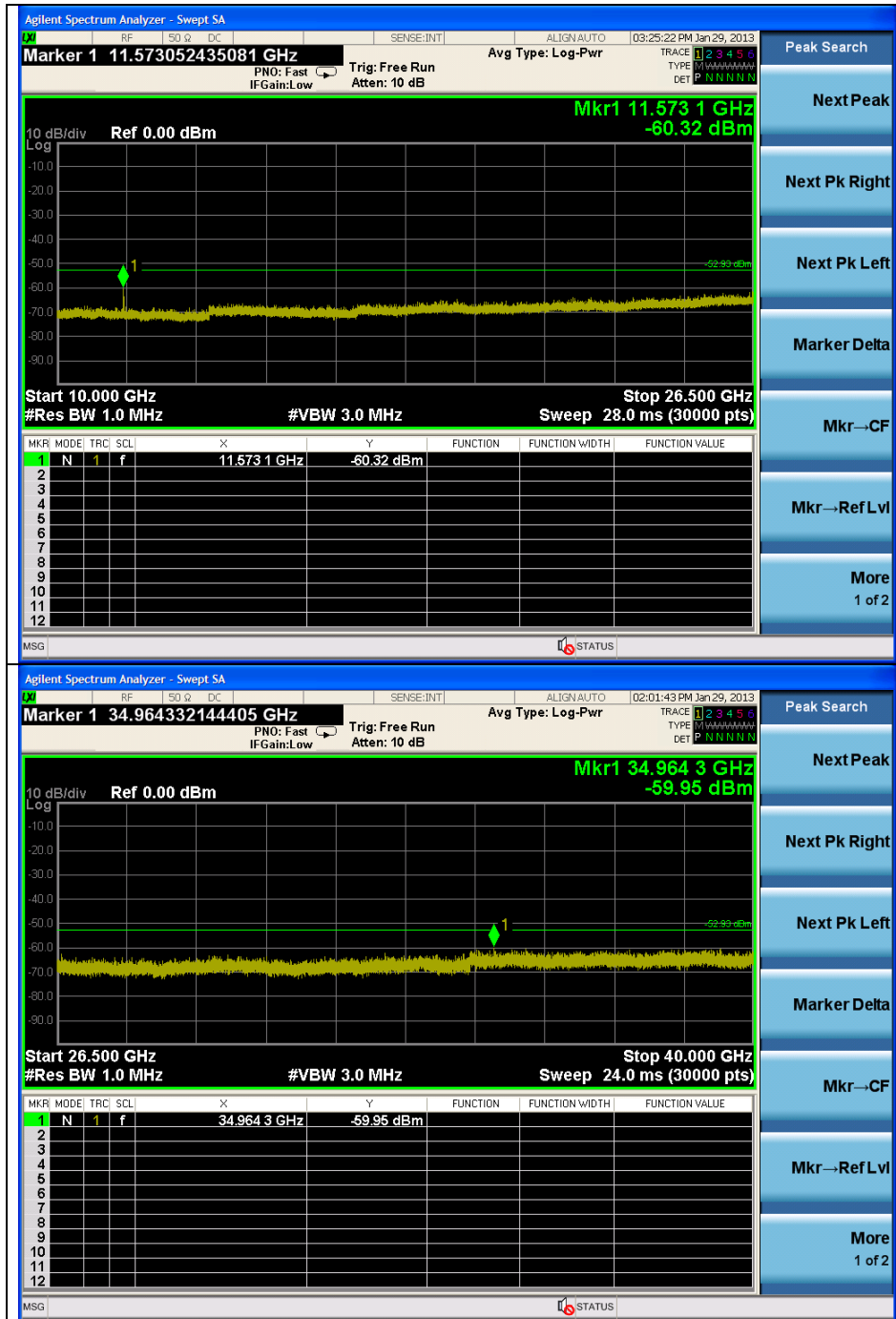

Note:

Offset (dB) = Attenuator(dB) + Cable loss (dB)

Result (dB m) = Spurious offset (dB) + Reading values (dB m)

Frequency (MHz)	Reading values (dB m)	Spurious offset (dB)	Result (dB m)
5 691.50	Noise floor	-	-
11 573.10	-60.32	22.81	-37.51
34 964.30	Noise floor	-	-

The results shown in this test report refer only to the sample(s) tested unless otherwise stated. This test report cannot be reproduced, except in full, without prior written permission of the Company.

High Channel



The results shown in this test report refer only to the sample(s) tested unless otherwise stated. This test report cannot be reproduced, except in full, without prior written permission of the Company.

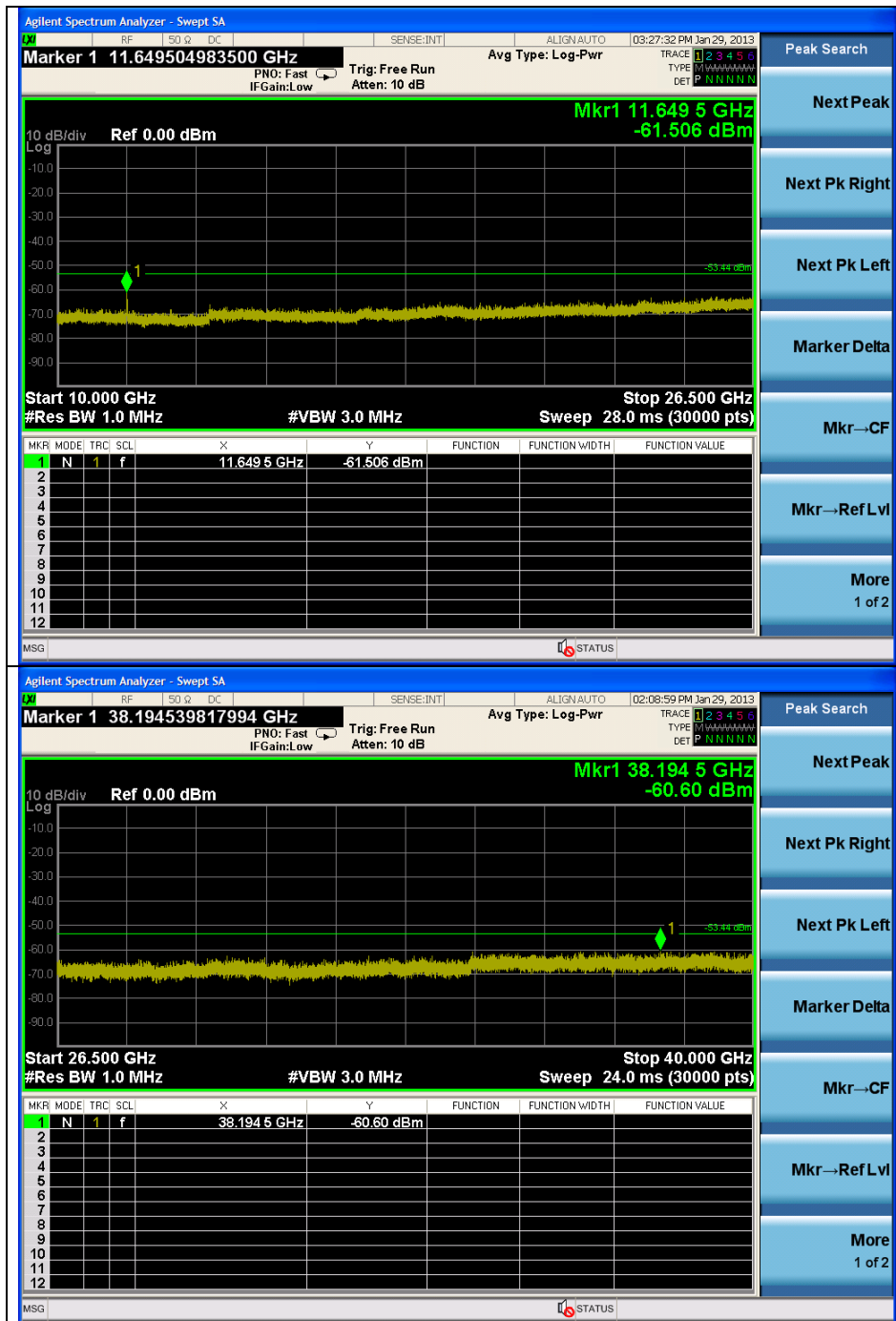

Note:

Offset (dB) = Attenuator(dB) + Cable loss (dB)

Result (dB m) = Spurious offset (dB) + Reading values (dB m)

Frequency (MHz)	Reading values (dB m)	Spurious offset (dB)	Result (dB m)
3 824.40	Noise floor	-	-
5 850.00	-77.32	21.06	-56.26
11 649.50	-61.51	22.76	-38.75
38 194.50	Noise floor	-	-

The results shown in this test report refer only to the sample(s) tested unless otherwise stated. This test report cannot be reproduced, except in full, without prior written permission of the Company.

OFDM : 802.11n_HT20(MCS0)
Low Channel



The results shown in this test report refer only to the sample(s) tested unless otherwise stated. This test report cannot be reproduced, except in full, without prior written permission of the Company.

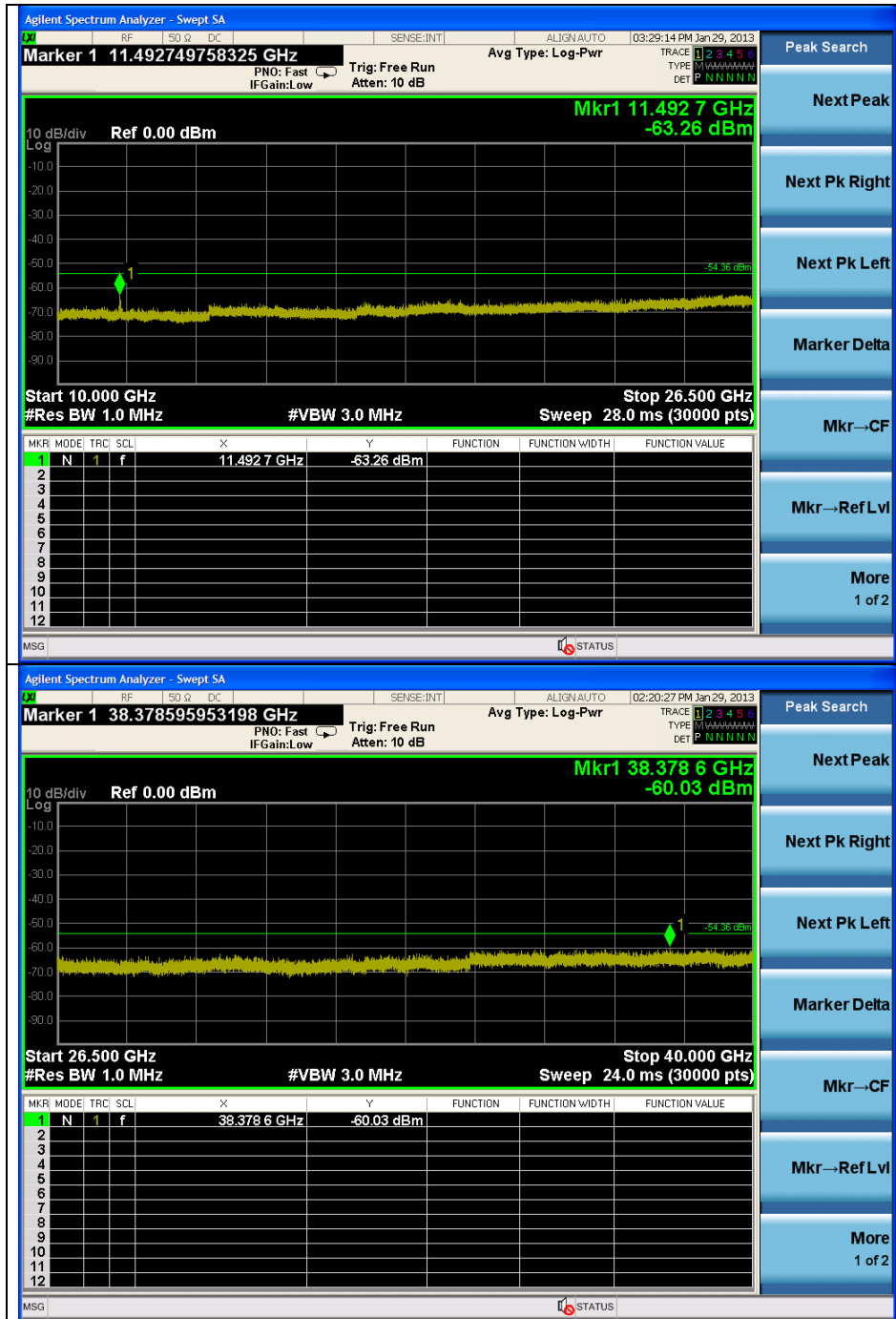

Note:

Offset (dB) = Attenuator(dB) + Cable loss (dB)

Result (dB m) = Spurious offset (dB) + Reading values (dB m)

Frequency (MHz)	Reading values (dB m)	Spurious offset (dB)	Result (dB m)
5 154.80	Noise floor	-	-
5 725.00	-70.93	20.70	-50.23
11 492.70	-63.26	23.22	-40.04
38 378.60	Noise floor	-	-

The results shown in this test report refer only to the sample(s) tested unless otherwise stated. This test report cannot be reproduced, except in full, without prior written permission of the Company.

Middle Channel

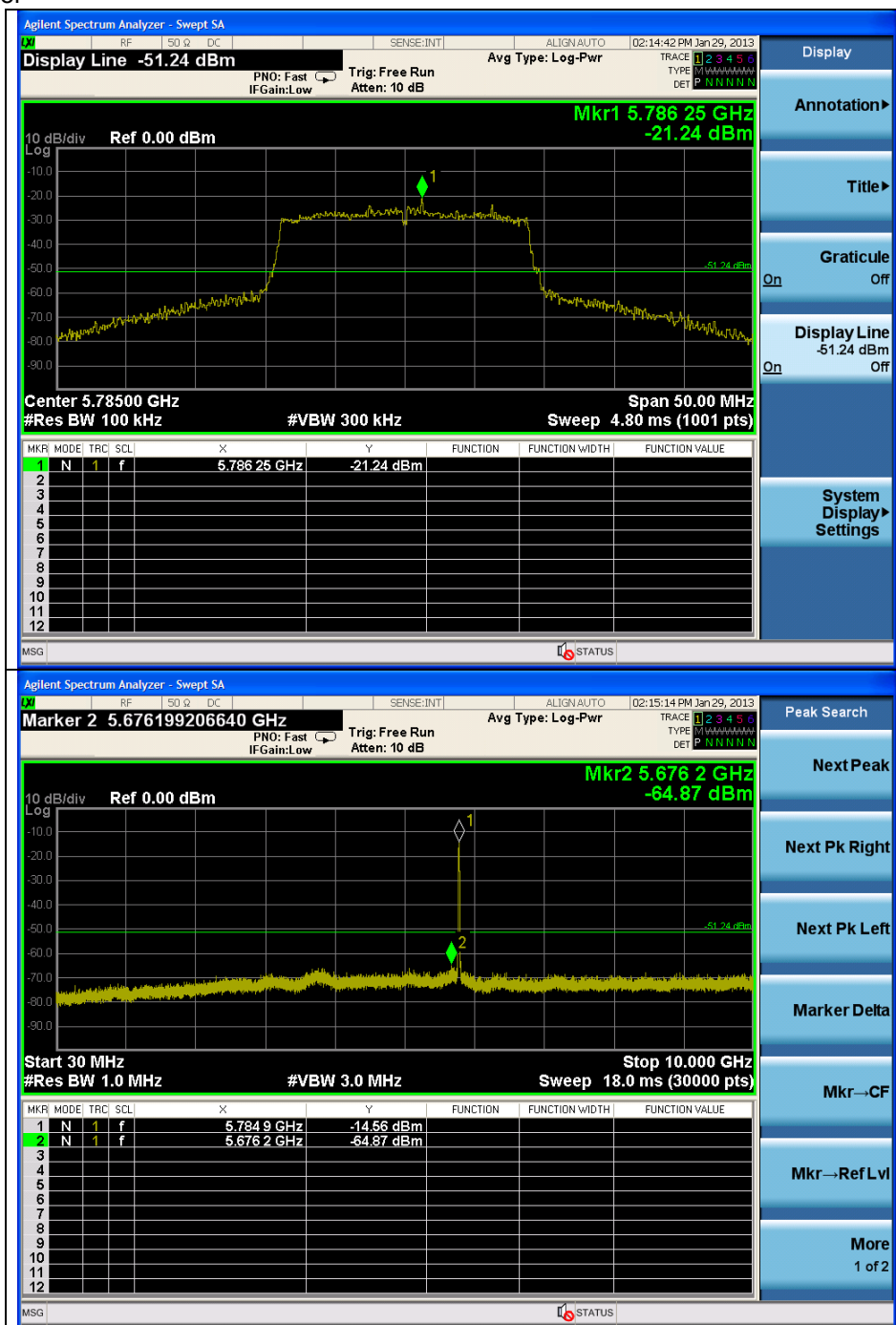

The results shown in this test report refer only to the sample(s) tested unless otherwise stated. This test report cannot be reproduced, except in full, without prior written permission of the Company.

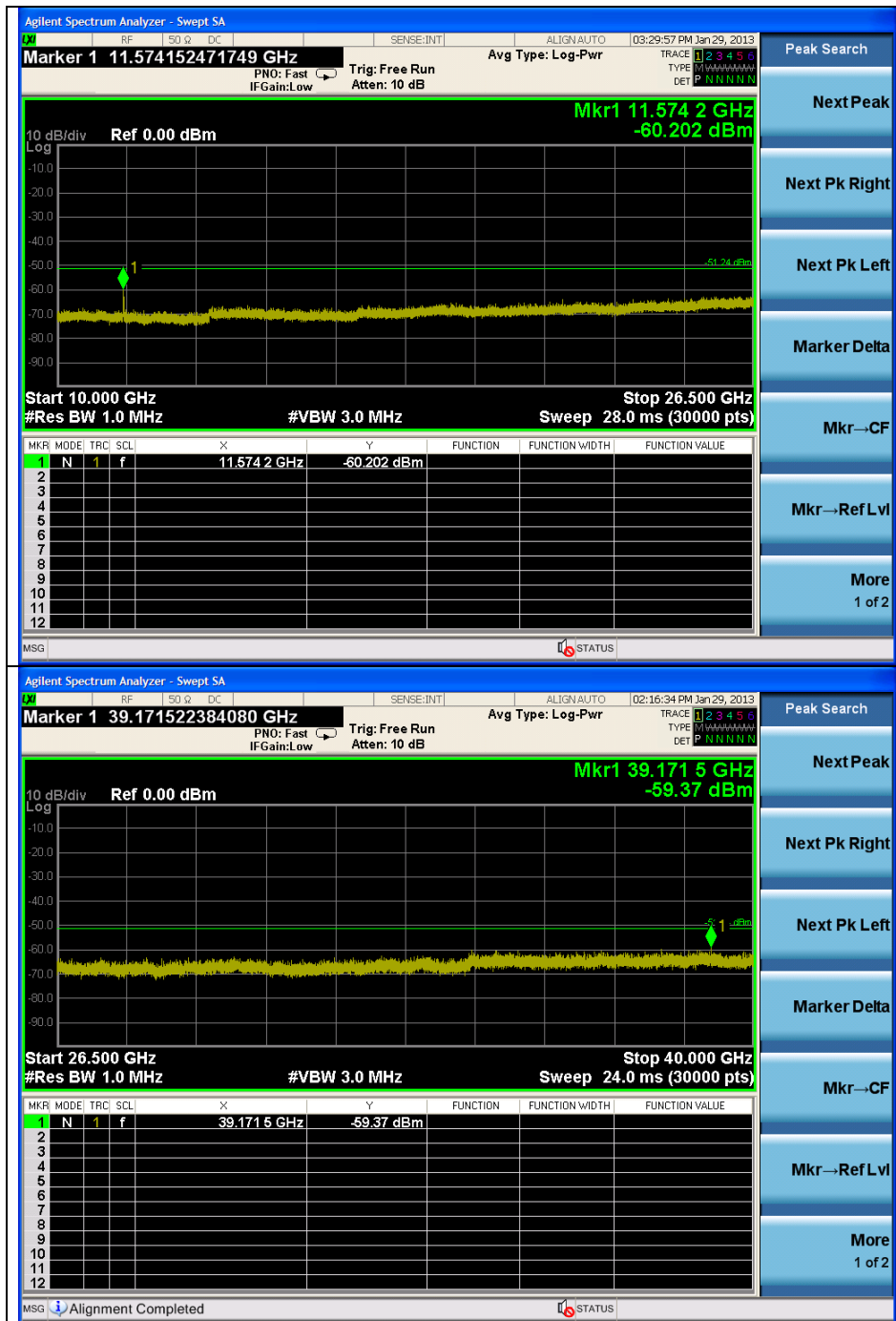

Note:

Offset (dB) = Attenuator(dB) + Cable loss (dB)

Result (dB m) = Spurious offset (dB) + Reading values (dB m)

Frequency (MHz)	Reading values (dB m)	Spurious offset (dB)	Result (dB m)
5 876.20	Noise floor	-	-
11 574.20	-60.20	22.81	-37.39
39 171.50	Noise floor	-	-

The results shown in this test report refer only to the sample(s) tested unless otherwise stated. This test report cannot be reproduced, except in full, without prior written permission of the Company.

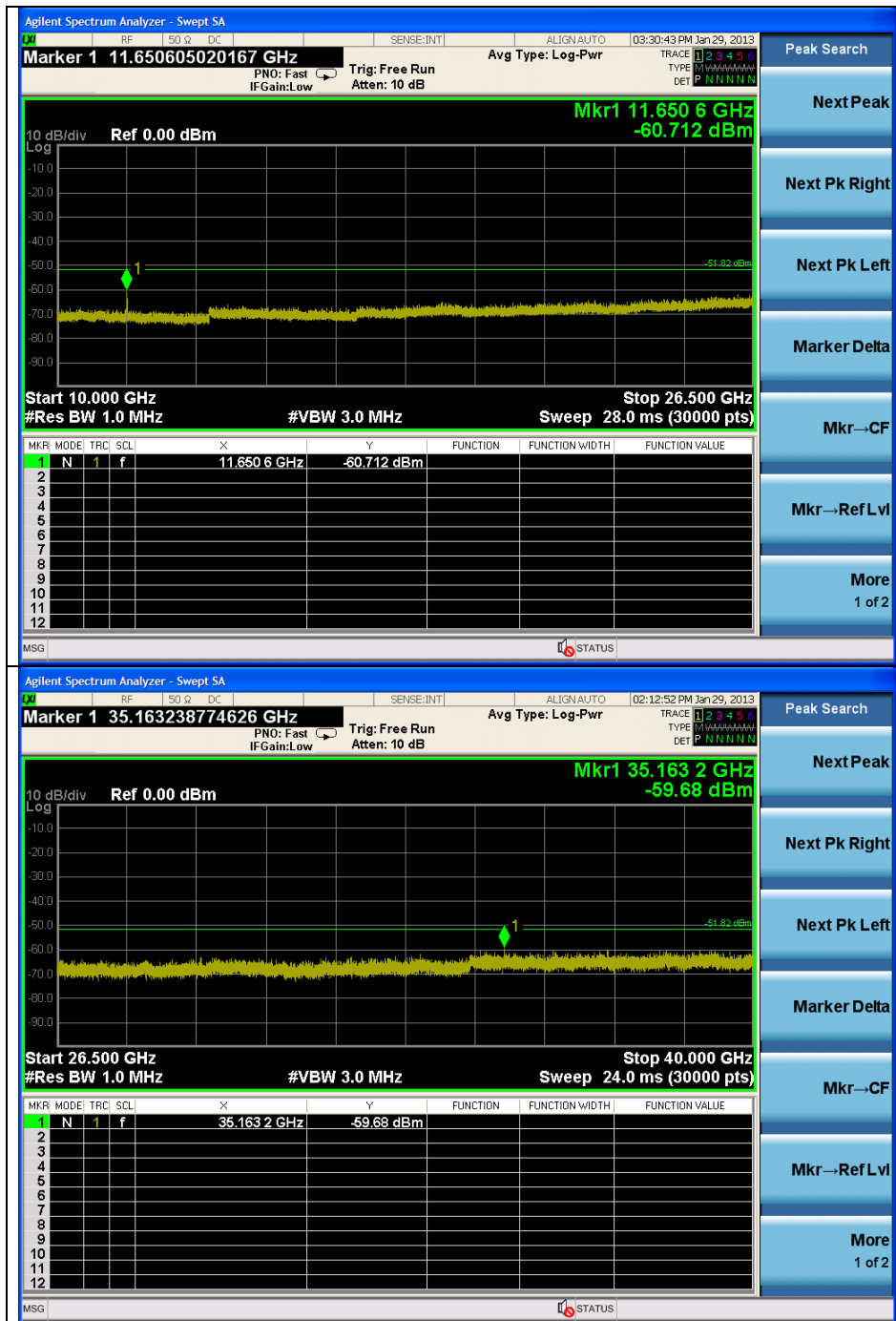

Note:

Offset (dB) = Attenuator(dB) + Cable loss (dB)

Result (dB m) = Spurious offset (dB) + Reading values (dB m)

Frequency (MHz)	Reading values (dB m)	Spurious offset (dB)	Result (dB m)
3 804.40	Noise floor	-	-
5 850.00	-76.66	21.06	-55.60
11 650.60	-60.71	22.73	-37.98
35 163.20	Noise floor	-	-

The results shown in this test report refer only to the sample(s) tested unless otherwise stated. This test report cannot be reproduced, except in full, without prior written permission of the Company.

OFDM : 802.11n_HT40(MCS0)
Low Channel

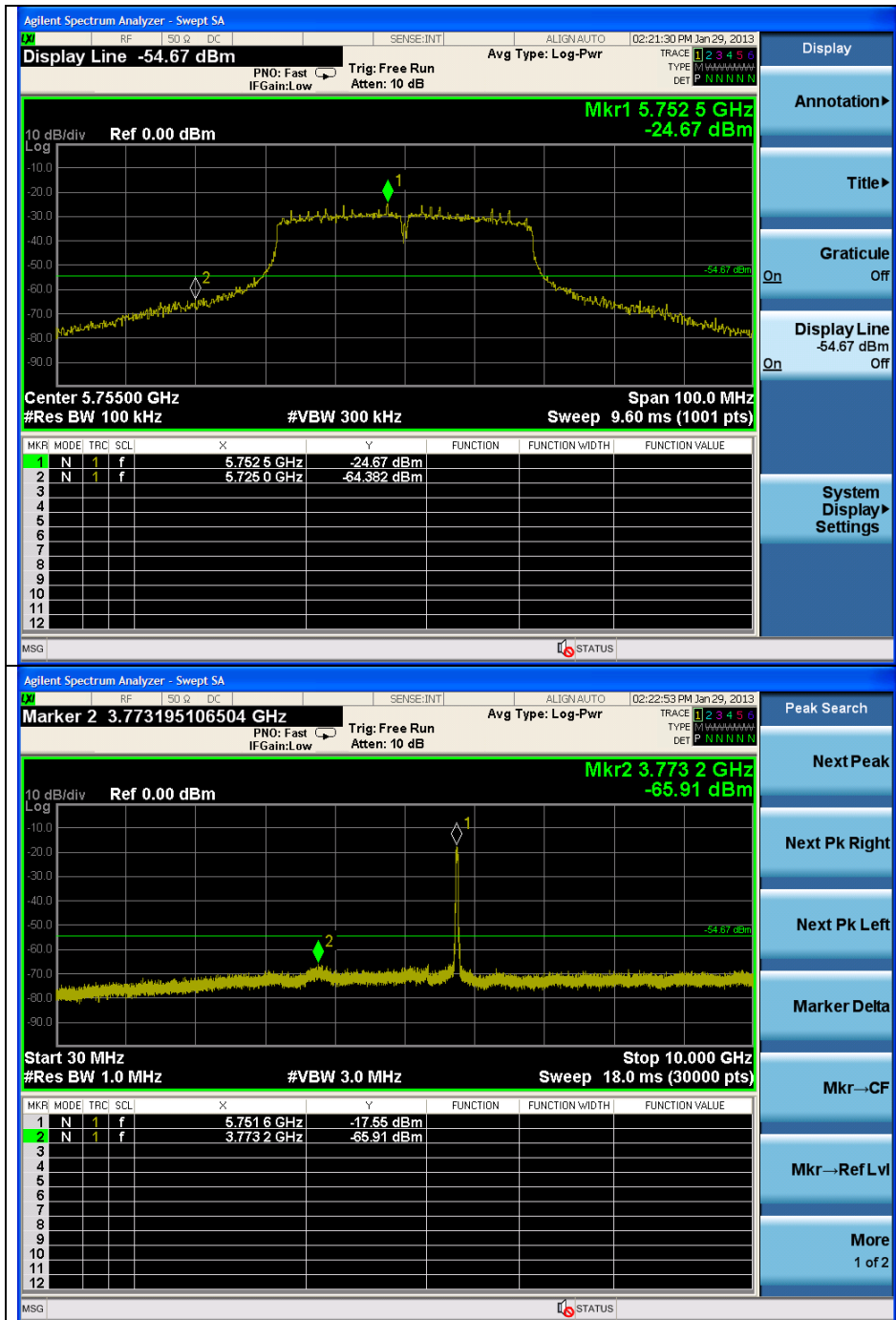

The results shown in this test report refer only to the sample(s) tested unless otherwise stated. This test report cannot be reproduced, except in full, without prior written permission of the Company.

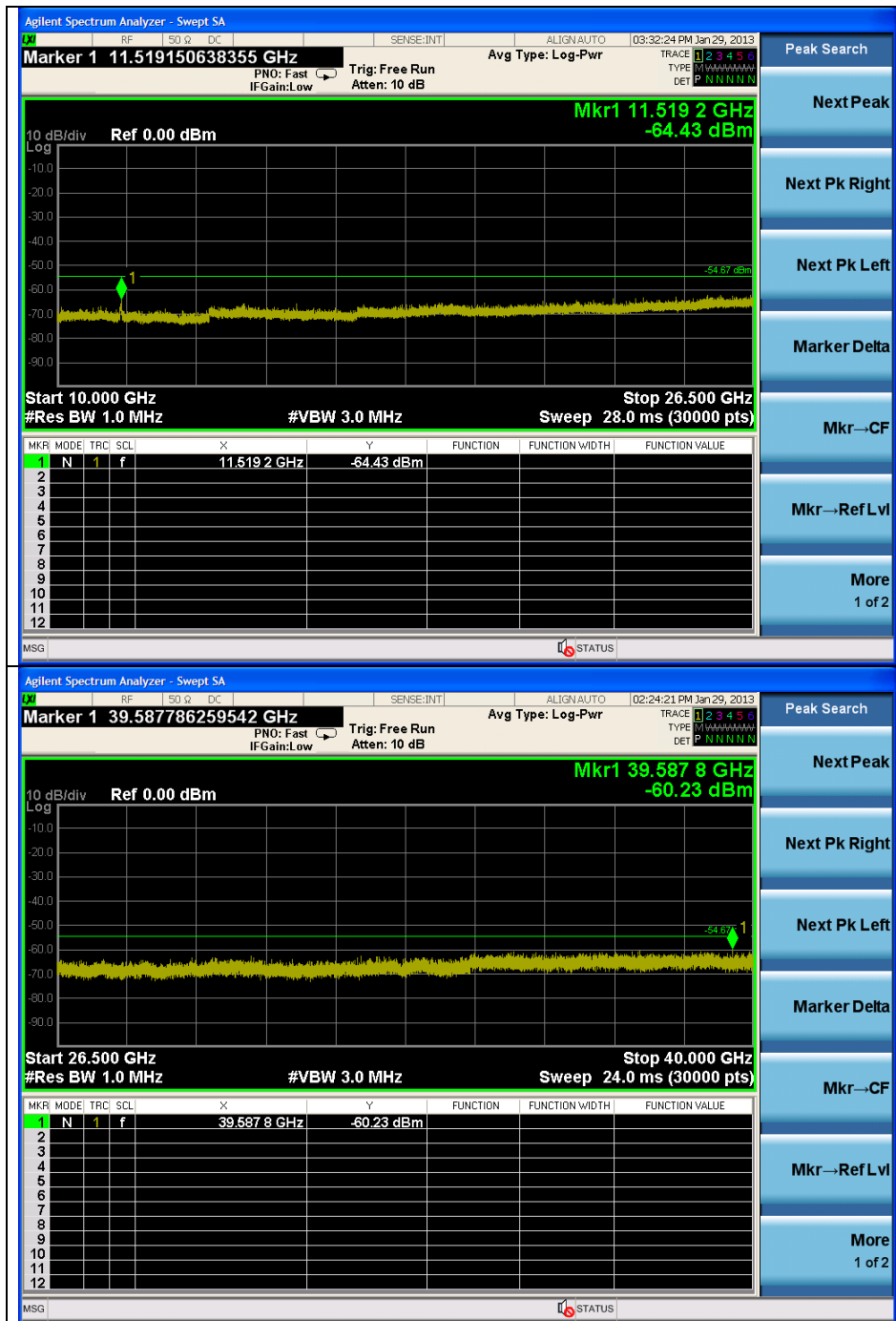

Note:

Offset (dB) = Attenuator(dB) + Cable loss (dB)

Result (dB m) = Spurious offset (dB) + Reading values (dB m)

Frequency (MHz)	Reading values (dB m)	Spurious offset (dB)	Result (dB m)
3 773.20	Noise floor	-	-
5 725.00	-64.38	20.70	-43.68
11 519.20	-64.43	23.22	-41.21
39 587.80	Noise floor	-	-

The results shown in this test report refer only to the sample(s) tested unless otherwise stated. This test report cannot be reproduced, except in full, without prior written permission of the Company.

High Channel



The results shown in this test report refer only to the sample(s) tested unless otherwise stated. This test report cannot be reproduced, except in full, without prior written permission of the Company.

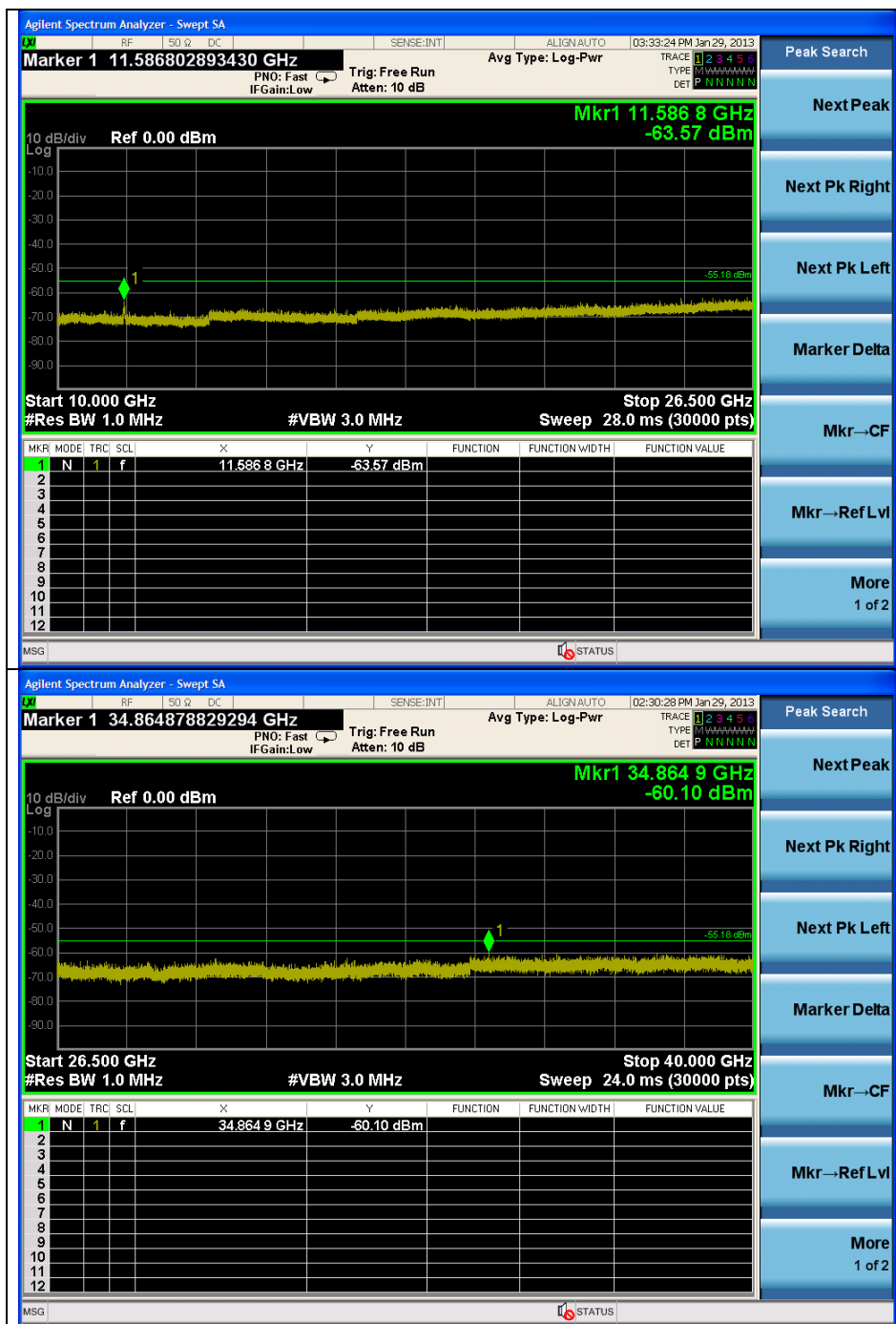

Note:

Offset (dB) = Attenuator(dB) + Cable loss (dB)

Result (dB m) = Spurious offset (dB) + Reading values (dB m)

Frequency (MHz)	Reading values (dB m)	Spurious offset (dB)	Result (dB m)
5 687.80	Noise floor	-	-
5 850.00	-78.55	21.06	-57.49
11 586.80	-63.57	22.67	-40.90
34 864.90	Noise floor	-	-

The results shown in this test report refer only to the sample(s) tested unless otherwise stated. This test report cannot be reproduced, except in full, without prior written permission of the Company.

3. 6 dB Bandwidth Measurement

3.1. Test Setup

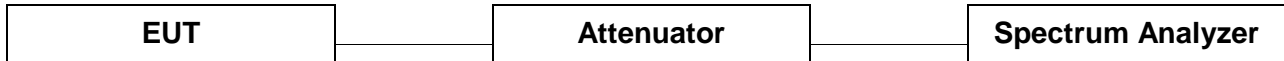

3.2. Limit

According to §15.247(a)(2), systems using digital modulation techniques may operate in the 902 ~928 MHz, 2 400 ~ 2 483.5 MHz, and 5 725 ~ 5 825 MHz bands. The minimum of 6 dB Bandwidth shall be at least 500 kHz

3.3. Test Procedure

3.3.1. 6 dB Bandwidth

All data rates and modes were investigated for this test. The full data for the worst case data rate are reported in this section.

The test follows section 7.1 of FCC KDB Publication 558074

1. Set resolution bandwidth (RBW) = 1 – 5 % of DTS BW, not to exceed 100 kHz
2. Set the video bandwidth (VBW) $\geq 3 \times$ RBW.
3. Detector = Peak.
4. Trace mode = max hold.
5. Sweep = auto couple.
6. Allow the trace to stabilize.
7. Measure the maximum width of the emission that is constrained by the frequencies associated with the two outermost amplitude point (upper and lower) that are attenuated by 6 dB relative to the maximum level measured in the fundamental emission.

The results shown in this test report refer only to the sample(s) tested unless otherwise stated. This test report cannot be reproduced, except in full, without prior written permission of the Company.

3.4. Test Results

Ambient temperature : (23 ± 2) °C

Relative humidity : 47 % R.H.

Operation Mode	Data Rate (Mbps)	Channel	Channel Frequency (MHz)	6 dB Bandwidth (MHz)	Minimum Limit (MHz)
DSSS (802.11b)	1	Low	2 412	9.50	0.5
		Middle	2 437	10.00	
		High	2 462	10.00	
OFDM (802.11g)	6	Low	2 412	15.55	
		Middle	2 437	15.25	
		High	2 462	15.75	
OFDM (802.11n_HT20)	MCS0	Low	2 412	15.90	
		Middle	2 437	15.95	
		High	2 462	16.45	
OFDM (802.11a)	6	Low	5 745	16.25	
		Middle	5 785	16.40	
		High	5 825	16.30	
OFDM (802.11n_HT20)	MCS0	Low	5 745	17.50	
		Middle	5 785	17.00	
		High	5 825	17.35	
OFDM (802.11n_HT40)	MCS0	Low	5 755	34.80	
		High	5 795	35.10	

The results shown in this test report refer only to the sample(s) tested unless otherwise stated. This test report cannot be reproduced, except in full, without prior written permission of the Company.

6 dB Bandwidth
DSSS : 802.11b
 Low Channel

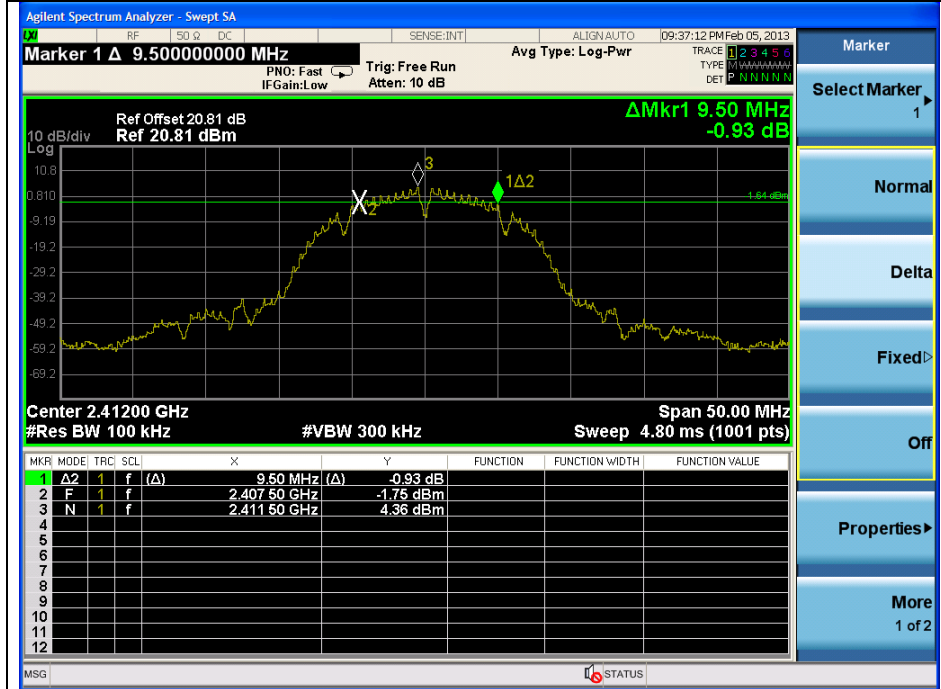

Middle Channel



The results shown in this test report refer only to the sample(s) tested unless otherwise stated. This test report cannot be reproduced, except in full, without prior written permission of the Company.

High Channel

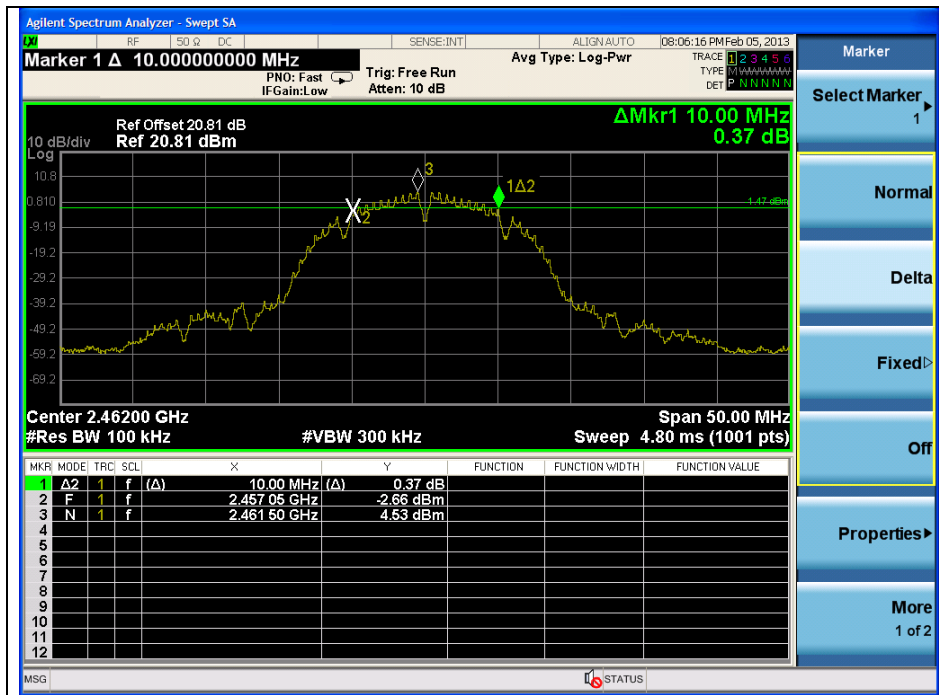

OFDM : 802.11g

Low Channel

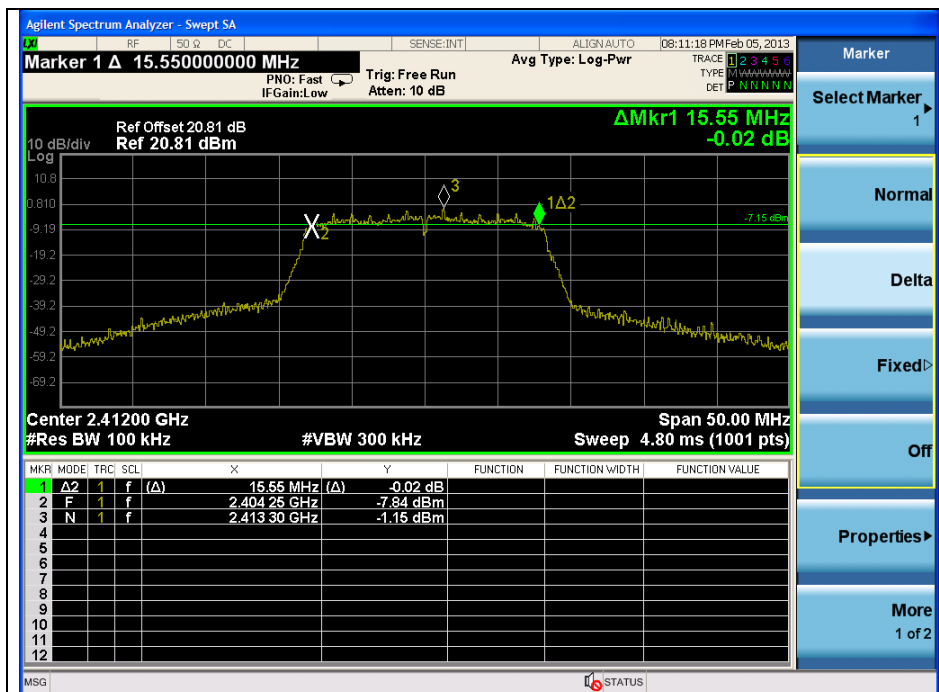

The results shown in this test report refer only to the sample(s) tested unless otherwise stated. This test report cannot be reproduced, except in full, without prior written permission of the Company.

Middle Channel

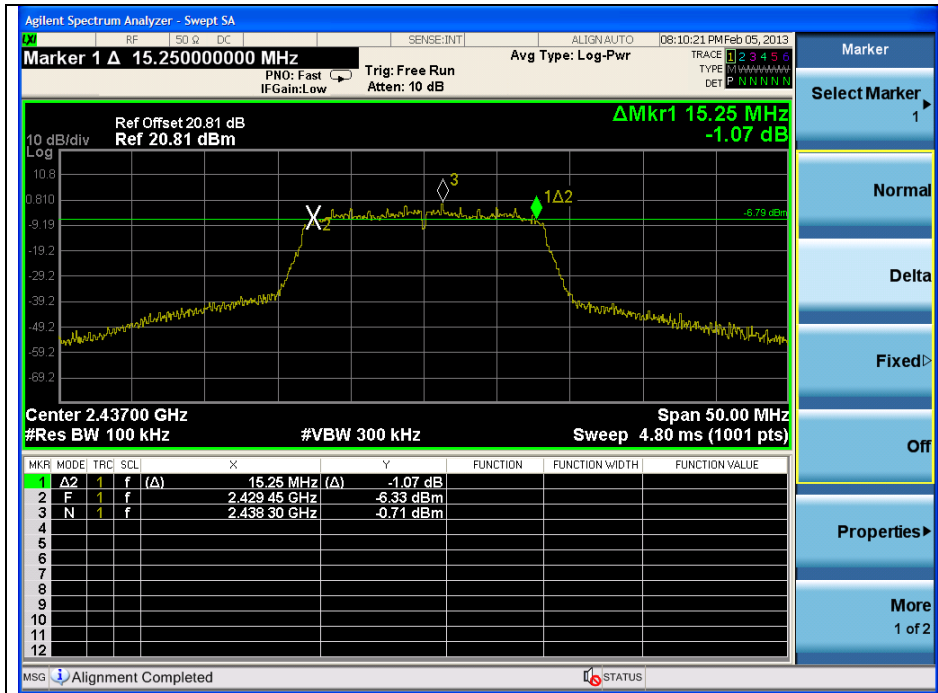

High Channel

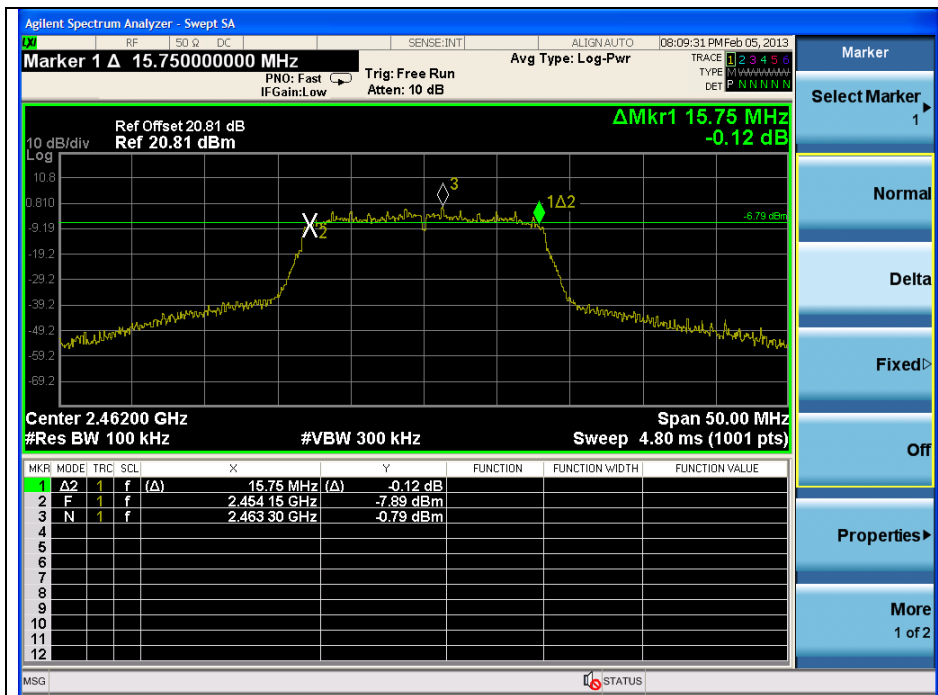

The results shown in this test report refer only to the sample(s) tested unless otherwise stated. This test report cannot be reproduced, except in full, without prior written permission of the Company.

OFDM : 802.11n_HT20

Low Channel

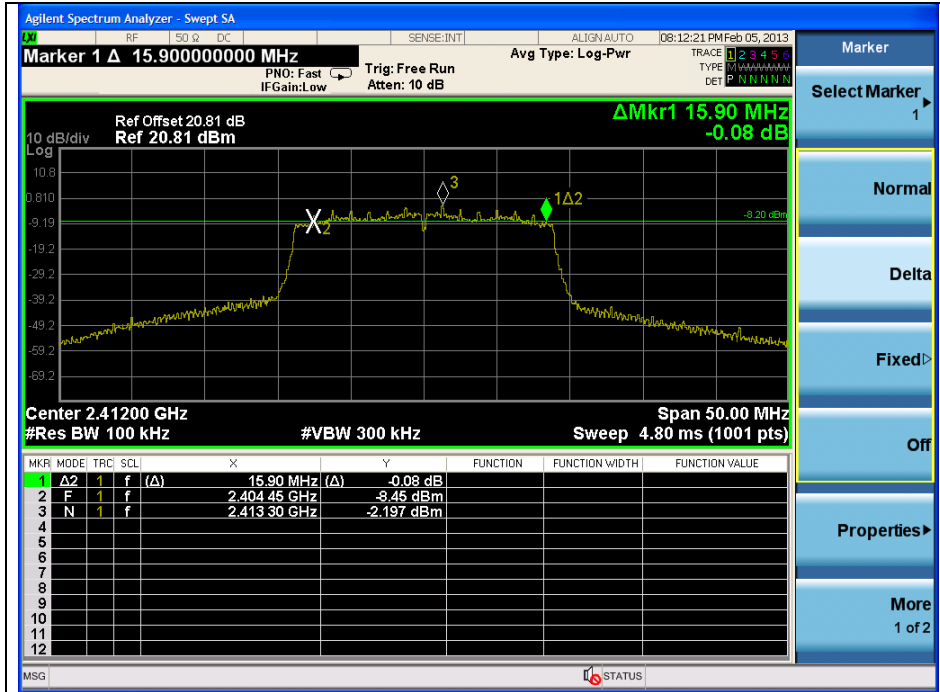

Middle Channel



The results shown in this test report refer only to the sample(s) tested unless otherwise stated. This test report cannot be reproduced, except in full, without prior written permission of the Company.

High Channel

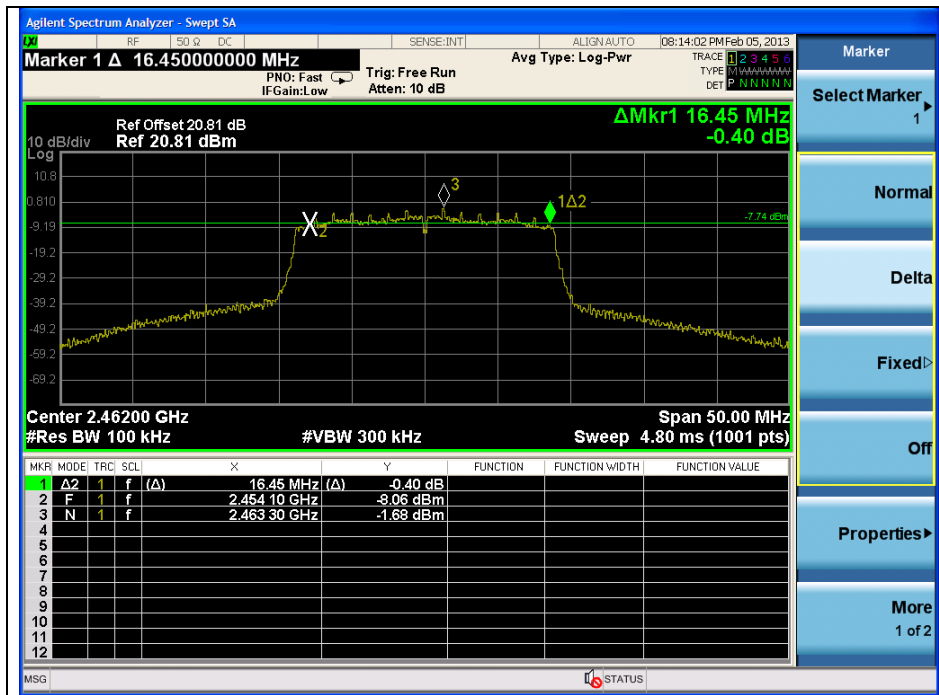

OFDM : 802.11a

Low Channel

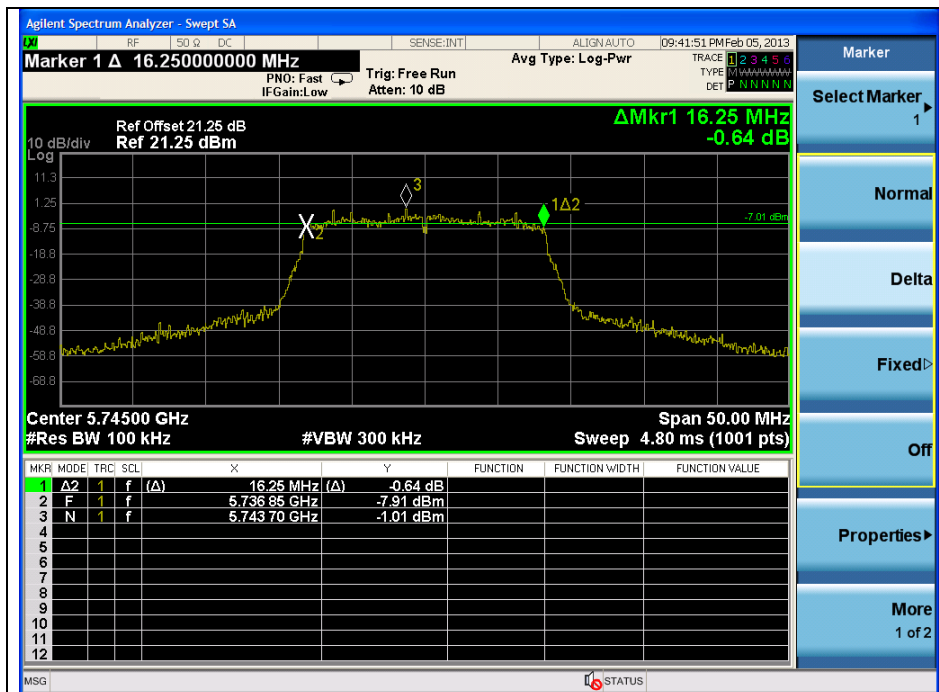

The results shown in this test report refer only to the sample(s) tested unless otherwise stated. This test report cannot be reproduced, except in full, without prior written permission of the Company.

Middle Channel



High Channel

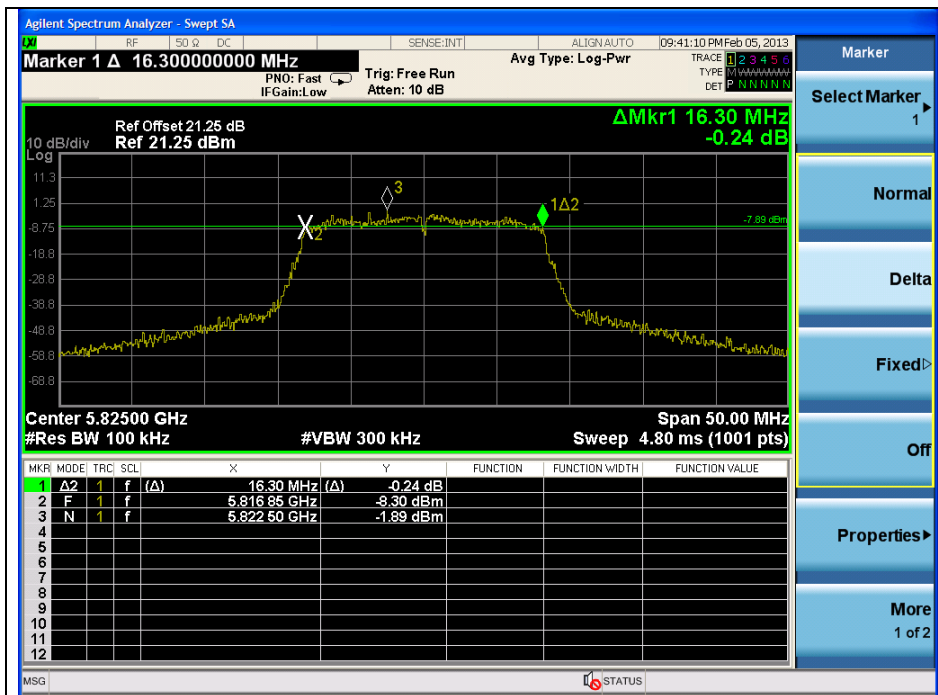

The results shown in this test report refer only to the sample(s) tested unless otherwise stated. This test report cannot be reproduced, except in full, without prior written permission of the Company.

OFDM : 802.11n_HT20

Low Channel

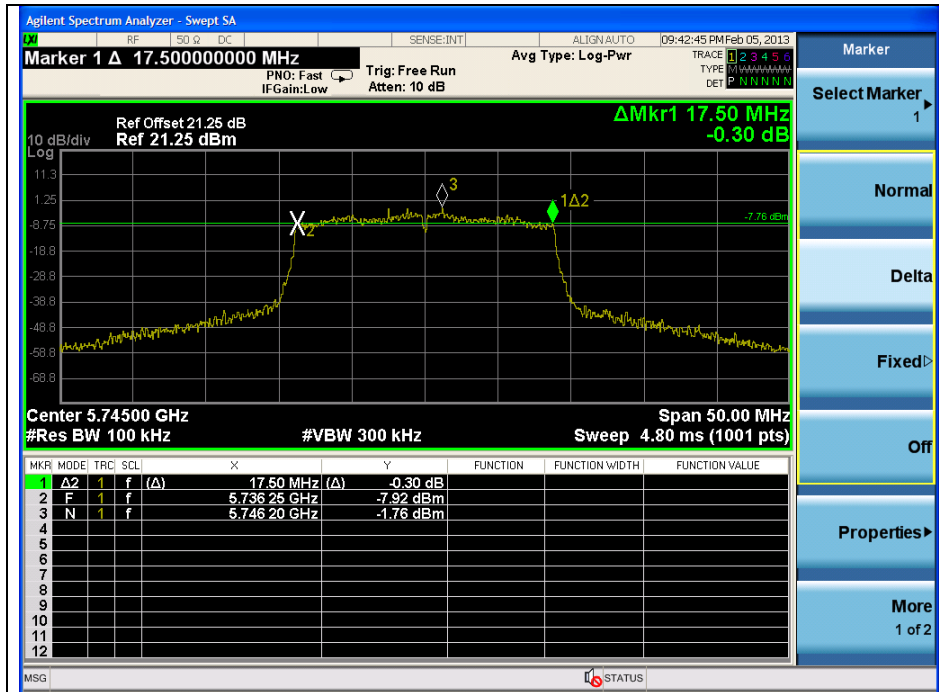

Middle Channel

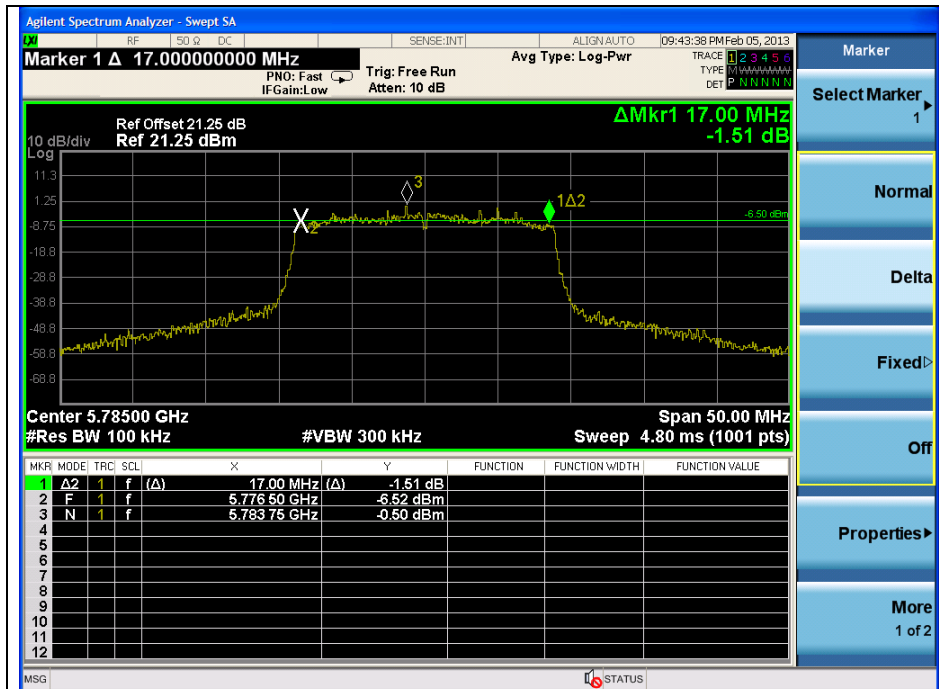

The results shown in this test report refer only to the sample(s) tested unless otherwise stated. This test report cannot be reproduced, except in full, without prior written permission of the Company.

High Channel

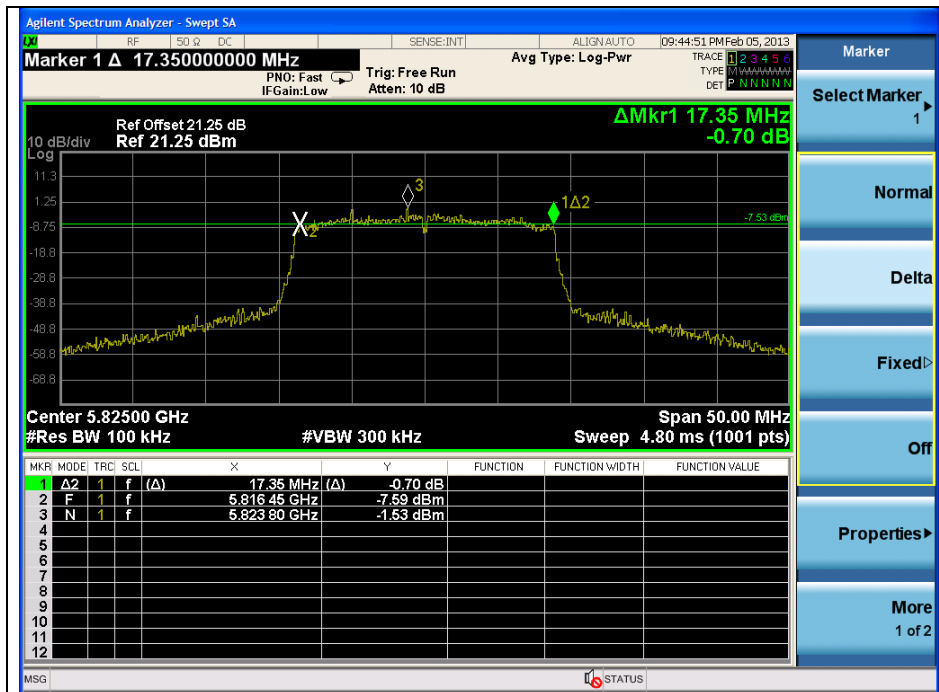

OFDM : 802.11n_HT40

Low Channel

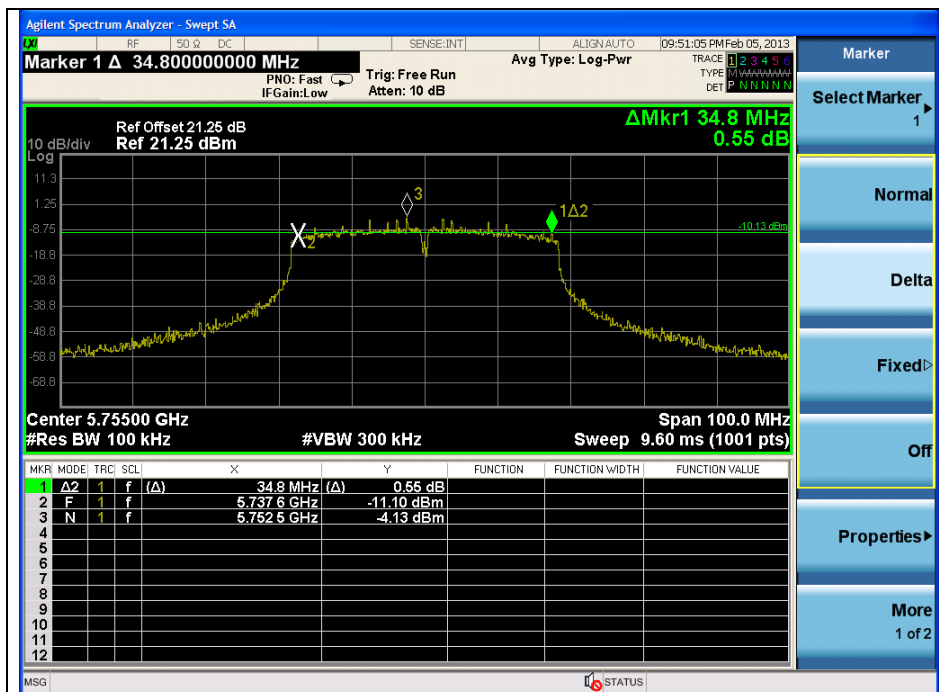

The results shown in this test report refer only to the sample(s) tested unless otherwise stated. This test report cannot be reproduced, except in full, without prior written permission of the Company.

High Channel



The results shown in this test report refer only to the sample(s) tested unless otherwise stated. This test report cannot be reproduced, except in full, without prior written permission of the Company.

4. Maximum Conducted Output Power Measurement

4.1. Test Setup

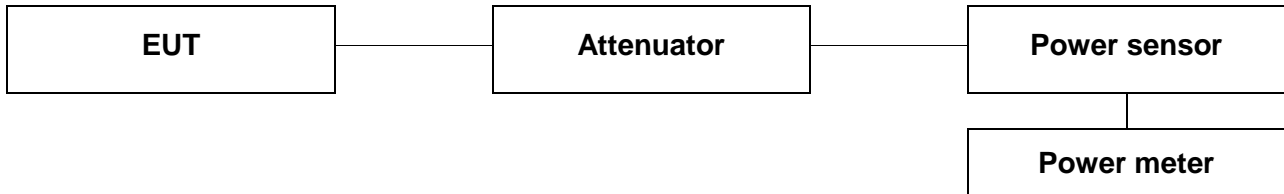

4.2. Limit

According to §15.247(b)(3), for systems using digital modulation in the 902 ~ 928 MHz, 2 400 ~2 483.5 MHz, and 5 725 ~ 5 850 MHz band: 1 Watt. As an alternative to a peak power measurement, compliance with the one watt limit can be based on a measurement of the maximum conducted output power. Maximum Conducted output Power is defined as the total transmit power delivered to all antennas and antenna elements averaged across all symbols in the signaling alphabet when the transmitter is operating at its maximum power control level. Power must be summed across all antenna elements. The average must not include any intervals during which the transmitter is off or is transmitting at a reduced power level. If multiple modes of operation are possible (e.g., alternative modulation methods), the maximum conducted output power is the highest total transmit power occurring in any mode.

According to §15.247(b)(4), the conducted output power limit specified in paragraph(b) of this section is based on the use of antenna with directional gains that do not exceed 6 dBi. Except as shown in paragraph(c) of this section, if transmitting antenna of directional gain greater than 6 dBi are used, the conducted output power from the intentional radiator shall be reduced below the stated values in paragraph (b)(1), (b)(2), and (b)(3) of this section, as appropriate, by the amount in dB that the directional gain of the antenna exceeds 6dBi.

4.3. Test Procedure

- Peak and average power meter method.

All data rates and modes were investigated for this test. The full data for the worst case data rate are reported in this section.

The test follows section 8.1.3 & 8.2.3 of FCC KDB Publication 558074

-The maximum peak conducted output power can be measured using a broad band peak RF power meter. The power meter must have a video bandwidth that is greater than or equal to the DTS bandwidth and shall utilize a fast, average-responding diode type sensor.

-This procedure provides an alternative for determining the RMS output power using a broadband RF average power meter with a thermocouple detector if the EUT can be configured to transmit continuously or if the power meter can be triggered/signal-gated such that the power is measured only when the EUT is transmitting at its maximum power control level.

1. Place the EUT on the table and set it in the transmitting mode.
2. Remove the antenna from the EUT and then connect a low loss RF cable from the antenna port to the Power sensor. (Nominal VBW is 50 MHz)
3. Measure peak & average power each channel.

The results shown in this test report refer only to the sample(s) tested unless otherwise stated. This test report cannot be reproduced, except in full, without prior written permission of the Company.

4.4. Test Results

Ambient temperature : (23 ± 2) °C
 Relative humidity : 47 % R.H.

Mode	Channel	Channel Frequency (MHz)	Data Rate (Mbps)	Attenuator + Cable offset (dB)	Average power Result (dB m)	Peak Power Result (dB m)
DSSS (802.11b)	Low	2 412	1	20.79	<u>16.04</u>	<u>18.99</u>
			2		16.02	18.55
			5.5		15.96	18.95
			11		15.72	18.90
	Middle	2 437	1	20.81	<u>16.34</u>	<u>19.32</u>
			2		16.27	19.23
			5.5		16.04	19.22
			11		15.88	19.31
	High	2 462	1	20.81	<u>16.39</u>	<u>19.33</u>
			2		16.31	19.31
			5.5		16.23	19.25
			11		15.94	19.30
OFDM (802.11g)	Low	2 412	6	20.79	<u>12.87</u>	<u>24.98</u>
			9		12.76	24.82
			12		12.64	24.46
			18		12.42	24.34
			24		12.20	24.43
			36		11.84	24.31
			48		11.48	24.27
			54		11.35	24.26
	Middle	2 437	6	20.81	<u>13.16</u>	<u>25.12</u>
			9		13.00	25.01
			12		12.87	24.58
			18		12.63	24.52
			24		12.42	24.54
			36		12.05	24.52
			48		11.69	24.27
			54		11.57	24.32
	High	2 462	6	20.81	<u>13.20</u>	<u>25.26</u>
			9		13.08	25.06
			12		12.93	24.64
			18		12.71	24.62
			24		12.49	24.60
			36		12.14	24.50
			48		11.78	24.38
			54		11.66	24.47

The results shown in this test report refer only to the sample(s) tested unless otherwise stated. This test report cannot be reproduced, except in full, without prior written permission of the Company.

Mode	Channel	Channel Frequency (MHz)	Data rate (Mbps)	Attenuator + Cable offset (dB)	Average power Result (dB m)	Peak Power Result (dB m)
OFDM (802.11n_HT20)	Low	2 412	MCS0	20.79	<u>11.75</u>	<u>24.27</u>
			MCS1		11.50	24.22
			MCS2		11.28	24.16
			MCS3		11.08	23.74
			MCS4		10.74	23.44
			MCS5		10.55	23.48
			MCS6		10.29	23.19
			MCS7		10.02	23.25
	Middle	2 437	MCS0	20.81	<u>11.92</u>	<u>24.28</u>
			MCS1		11.67	24.20
			MCS2		11.45	24.26
			MCS3		11.27	24.01
			MCS4		10.96	23.53
			MCS5		10.66	23.50
			MCS6		10.52	23.28
			MCS7		10.30	23.47
	High	2 462	MCS0	20.81	<u>12.05</u>	<u>24.31</u>
			MCS1		11.76	24.28
			MCS2		11.54	24.28
			MCS3		11.34	23.85
			MCS4		11.05	23.63
			MCS5		10.77	23.62
			MCS6		10.51	23.70
			MCS7		10.24	23.48

The results shown in this test report refer only to the sample(s) tested unless otherwise stated. This test report cannot be reproduced, except in full, without prior written permission of the Company.

Mode	Channel	Channel Frequency (MHz)	Data rate (Mbps)	Attenuator + Cable offset (dB)	Average power Result (dB m)	Peak Power Result (dB m)
OFDM (802.11a)	Low	5 745	6	21.25	<u>9.63</u>	<u>20.04</u>
			9		9.61	20.02
			12		9.43	19.50
			18		9.17	19.53
			24		9.02	19.49
			36		8.63	19.66
			48		8.41	19.52
			54		8.18	19.30
	Middle	5 785	6	21.25	<u>9.75</u>	<u>20.64</u>
			9		9.68	20.40
			12		9.51	20.01
			18		9.29	20.19
			24		9.13	20.11
			36		8.71	20.01
			48		8.51	19.99
			54		8.28	20.04
	High	5 825	6	21.27	<u>9.36</u>	<u>20.18</u>
			9		9.27	20.16
			12		9.14	20.02
			18		8.91	19.75
			24		8.74	19.74
			36		8.38	19.80
			48		8.11	20.01
			54		7.98	19.65

The results shown in this test report refer only to the sample(s) tested unless otherwise stated. This test report cannot be reproduced, except in full, without prior written permission of the Company.

Mode	Channel	Channel Frequency (MHz)	Data rate (Mbps)	Attenuator + Cable offset (dB)	Average power Result (dB m)	Peak Power Result (dB m)
OFDM (802.11_HT20)	Low	5 745	MCS0	21.25	<u>9.56</u>	<u>19.68</u>
			MCS1		9.28	19.60
			MCS2		9.10	19.45
			MCS3		8.87	19.40
			MCS4		8.68	19.55
			MCS5		8.39	19.26
			MCS6		8.22	19.05
	Middle	5 785	MCS0	21.25	<u>9.61</u>	<u>20.38</u>
			MCS1		9.43	20.30
			MCS2		9.36	20.16
			MCS3		9.21	20.00
			MCS4		9.08	19.89
			MCS5		8.89	20.21
			MCS6		8.71	20.04
	High	5 825	MCS0	21.27	<u>9.32</u>	<u>19.90</u>
			MCS1		9.03	19.82
			MCS2		8.88	19.87
			MCS3		8.71	19.85
			MCS4		8.55	19.66
			MCS5		8.50	19.55
			MCS6		8.38	19.50
OFDM (802.11_HT40)	Low	5 755	MCS0	21.24	<u>8.20</u>	<u>20.20</u>
			MCS1		7.75	20.02
			MCS2		7.41	19.97
			MCS3		7.18	20.06
			MCS4		7.01	19.50
			MCS5		6.70	19.79
			MCS6		6.38	19.59
	High	5 795	MCS0	21.25	<u>8.35</u>	<u>19.45</u>
			MCS1		7.94	19.08
			MCS2		7.70	18.72
			MCS3		7.48	18.92
			MCS4		7.11	18.60
			MCS5		6.92	18.50
			MCS6		6.70	18.56
MCS7	6.48	18.54				

The results shown in this test report refer only to the sample(s) tested unless otherwise stated. This test report cannot be reproduced, except in full, without prior written permission of the Company.

5. Power Spectral Density Measurement

5.1. Test Setup

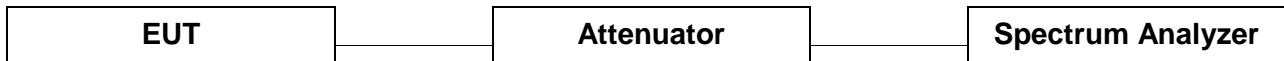

5.2. Limit

§15.247(e) For digitally modulated system, the power spectral density conducted from the intentional radiator to the antenna shall not be greater than 8 dB m in any 3 kHz band any time interval of continuous transmission. This power spectral density shall be determined in accordance with the provisions of paragraph (b) of this section. The same method of determining the conducted output power shall be used to determine the power spectral density.

5.3. Test Procedure

All data rates and modes were investigated for this test. The full data for the worst case data rate are reported in this section.

The measurements are recorded using the AVGPSD measurement procedure in section 9.2 of KDB 558074.

1. Use this procedure when the maximum conducted output power in the fundamental emission is used to demonstrate compliance. The EUT must be configured to transmit continuously at full power over the measurement duration.
2. Set the analyzer span to at least 1.5 times the DTS channel bandwidth.
3. Set the RBW ≥ 3 kHz
4. Set the VBW $\geq 3 \times$ RBW
5. Detector = power average (RMS) or sample detector (when RMS not available).
6. Ensure that the number of measurement points in the sweep $\geq 2 \times$ span/RBW
7. Sweep time = auto couple.
8. Employ trace averaging (RMS) mode over a minimum of 100 traces.
9. Use the peak marker function to determine the maximum amplitude level.

The results shown in this test report refer only to the sample(s) tested unless otherwise stated. This test report cannot be reproduced, except in full, without prior written permission of the Company.

5.4. Test Results

Ambient temperature : (23 ± 2) °C

Relative humidity : 47 % R.H.

Operation Mode	Data Rate (Mbps)	Channel	Frequency (MHz)	Measured PSD (dB m)	Maximum Limit (dB m)
DSSS (802.11b)	1	Low	2 412	-15.550	8
		Middle	2 437	-15.168	8
		High	2 462	-15.184	8
OFDM (802.11g)	6	Low	2 412	-22.390	8
		Middle	2 437	-22.150	8
		High	2 462	-21.760	8
OFDM (802.11n_HT20)	MCS0	Low	2 412	-22.131	8
		Middle	2 437	-21.736	8
		High	2 462	-21.524	8
OFDM (802.11a)	6	Low	5 745	-10.898	8
		Middle	5 785	-10.442	8
		High	5 805	-11.065	8
OFDM (802.11n_HT20)	MCS0	Low	5 745	-11.383	8
		Middle	5 785	-10.923	8
		High	5 805	-11.105	8
OFDM (802.11n_HT40)	MCS0	Low	5 755	-15.822	8
		High	5 795	-15.701	8

The results shown in this test report refer only to the sample(s) tested unless otherwise stated. This test report cannot be reproduced, except in full, without prior written permission of the Company.

DSSS : 802.11b
Low Channel

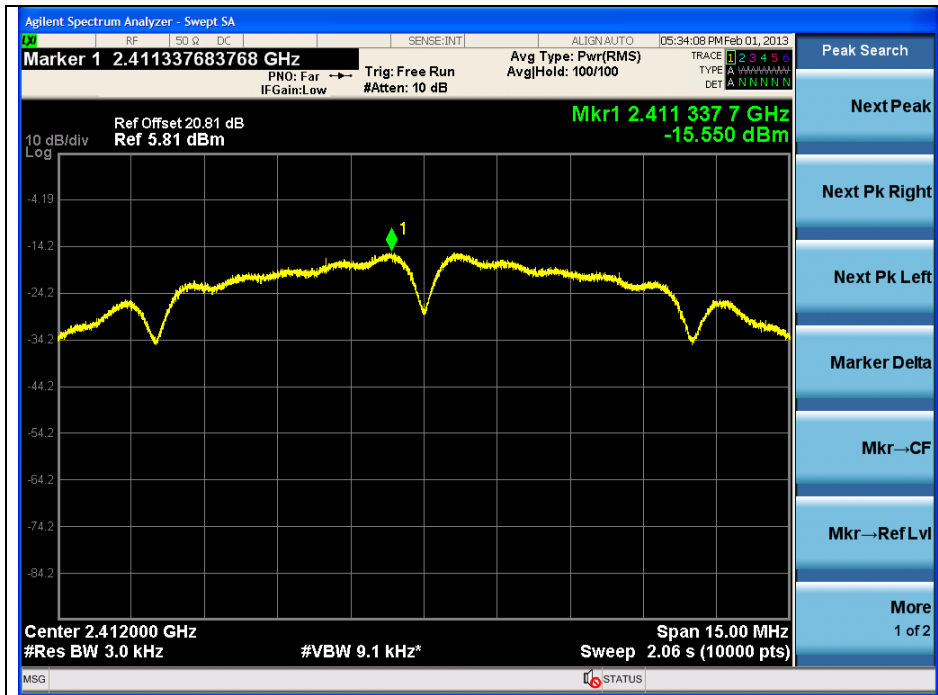

Middle Channel

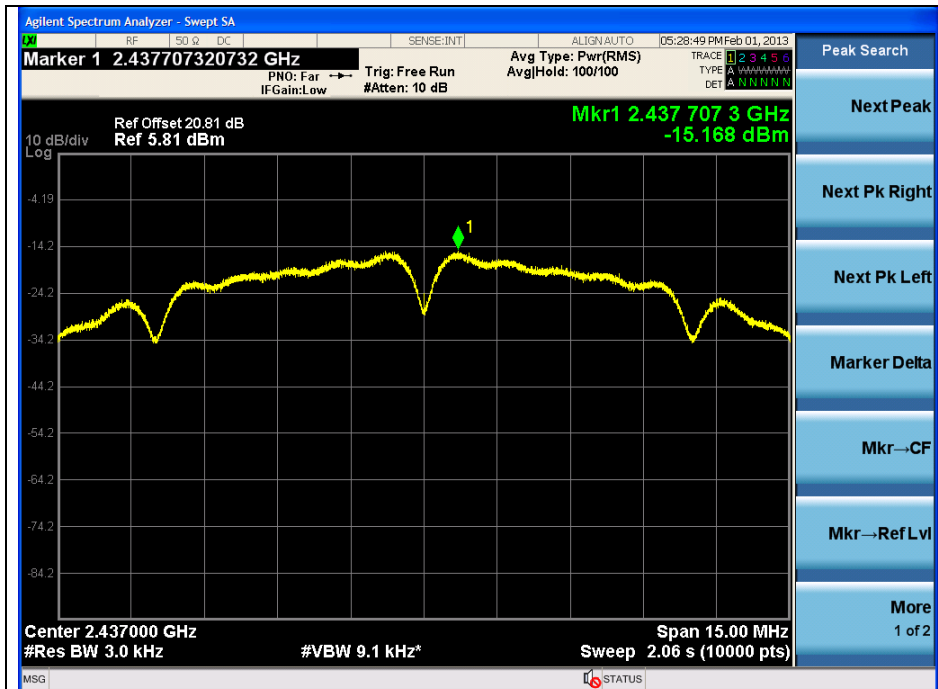

The results shown in this test report refer only to the sample(s) tested unless otherwise stated. This test report cannot be reproduced, except in full, without prior written permission of the Company.

High Channel

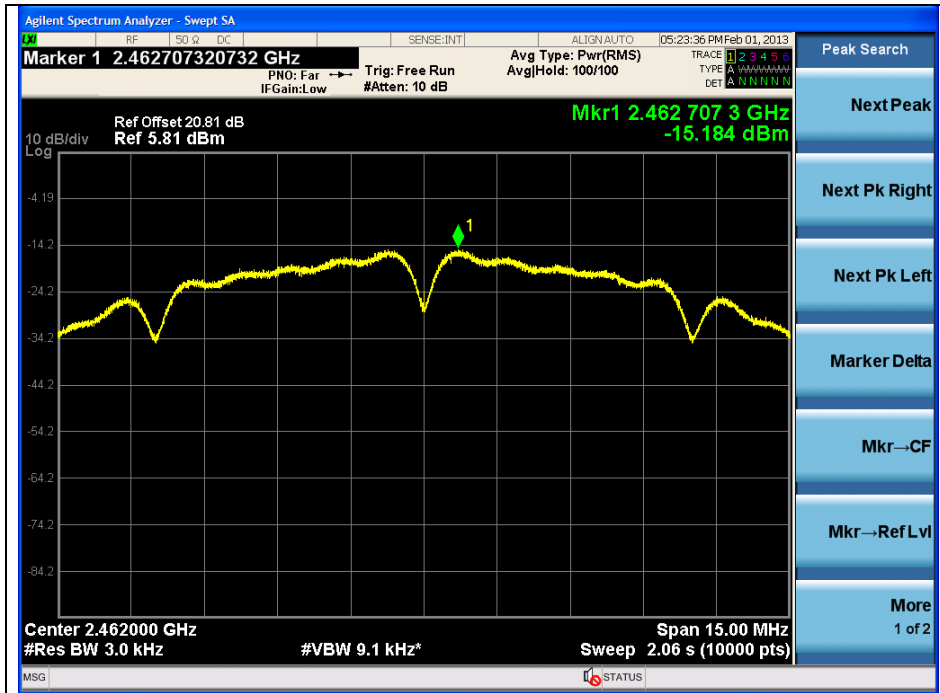

OFDM : 802.11g

Low Channel

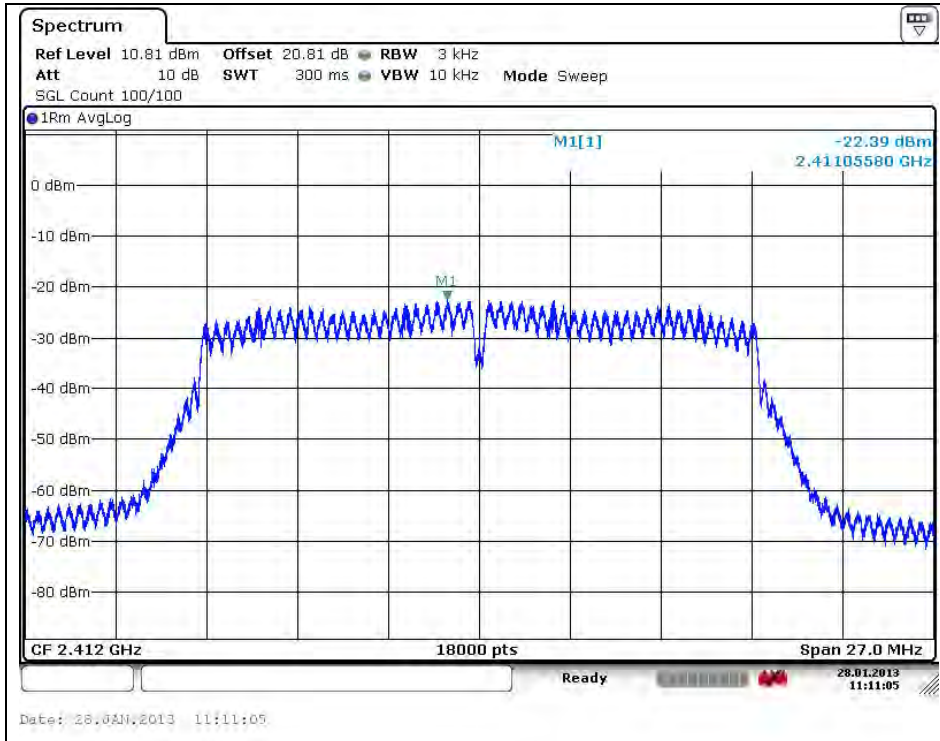

The results shown in this test report refer only to the sample(s) tested unless otherwise stated. This test report cannot be reproduced, except in full, without prior written permission of the Company.

Middle Channel

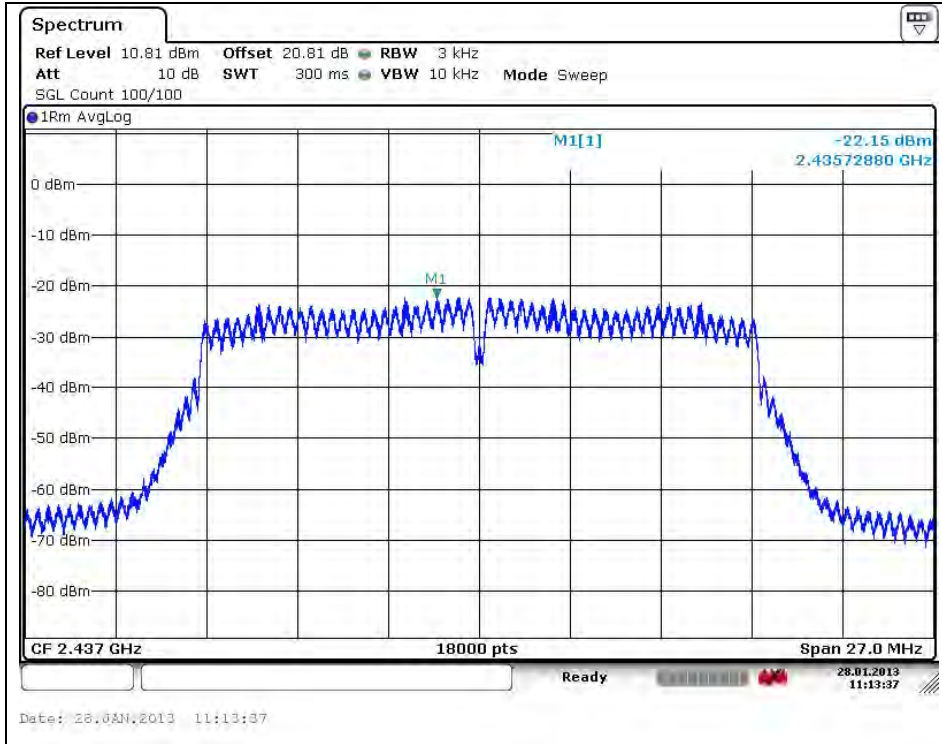

High Channel

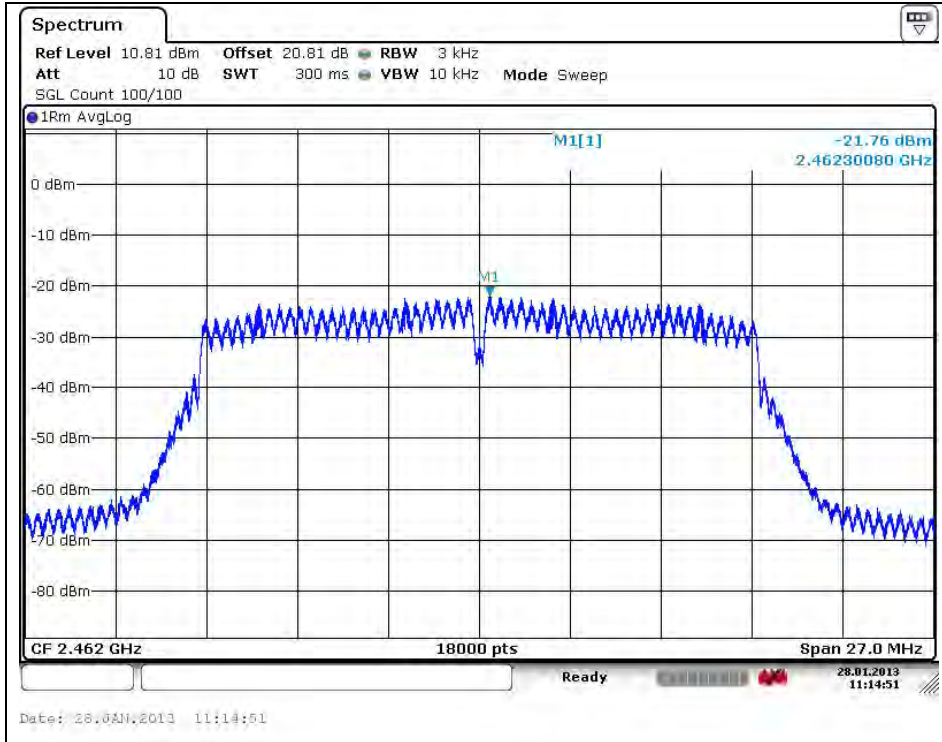

The results shown in this test report refer only to the sample(s) tested unless otherwise stated. This test report cannot be reproduced, except in full, without prior written permission of the Company.

OFDM : 802.11n_HT20

Low Channel

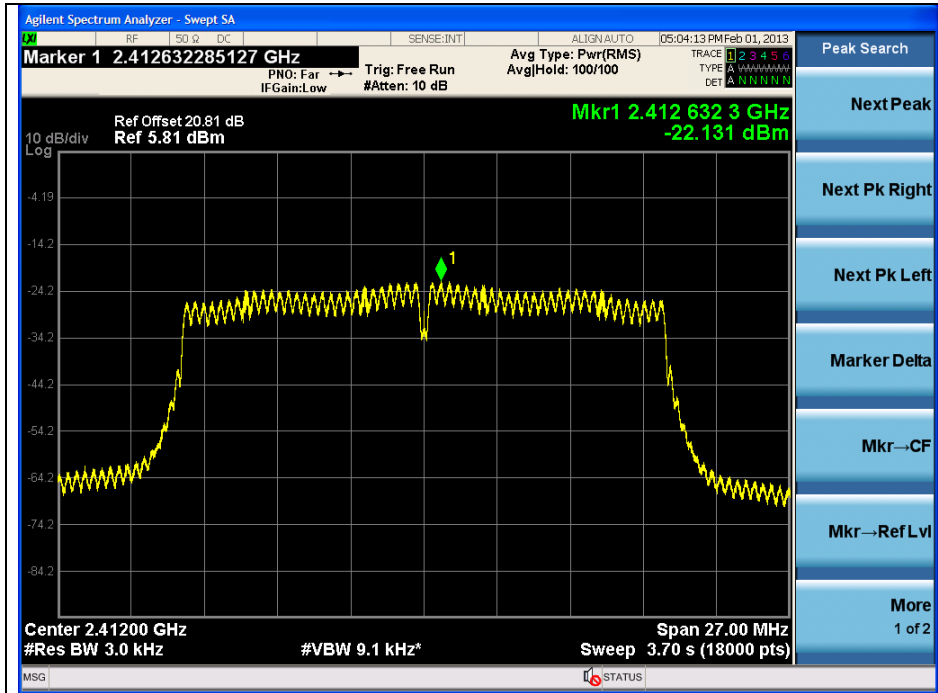

Middle Channel

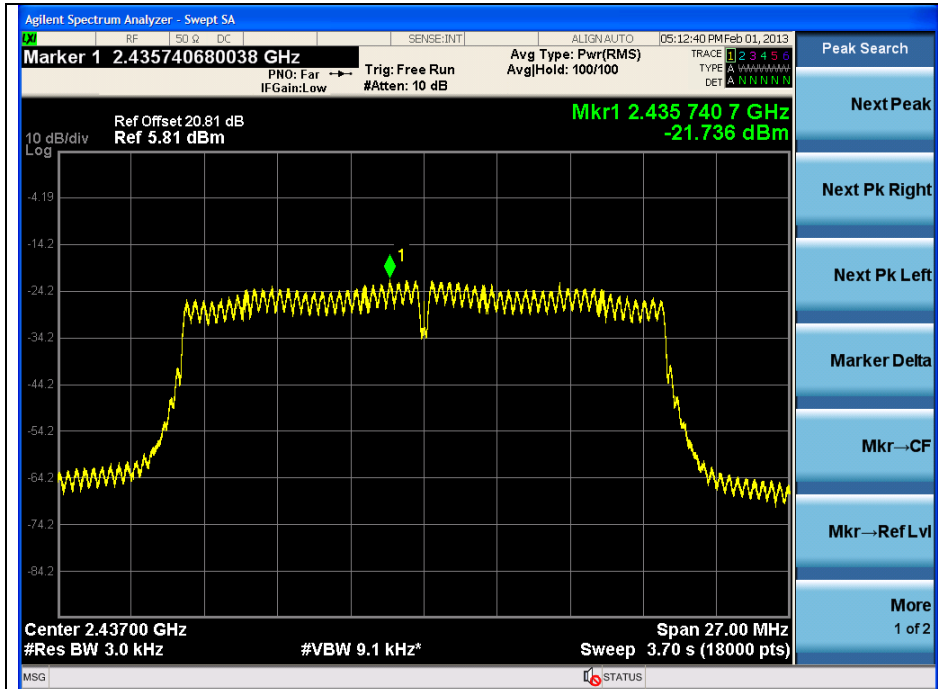

The results shown in this test report refer only to the sample(s) tested unless otherwise stated. This test report cannot be reproduced, except in full, without prior written permission of the Company.

High Channel

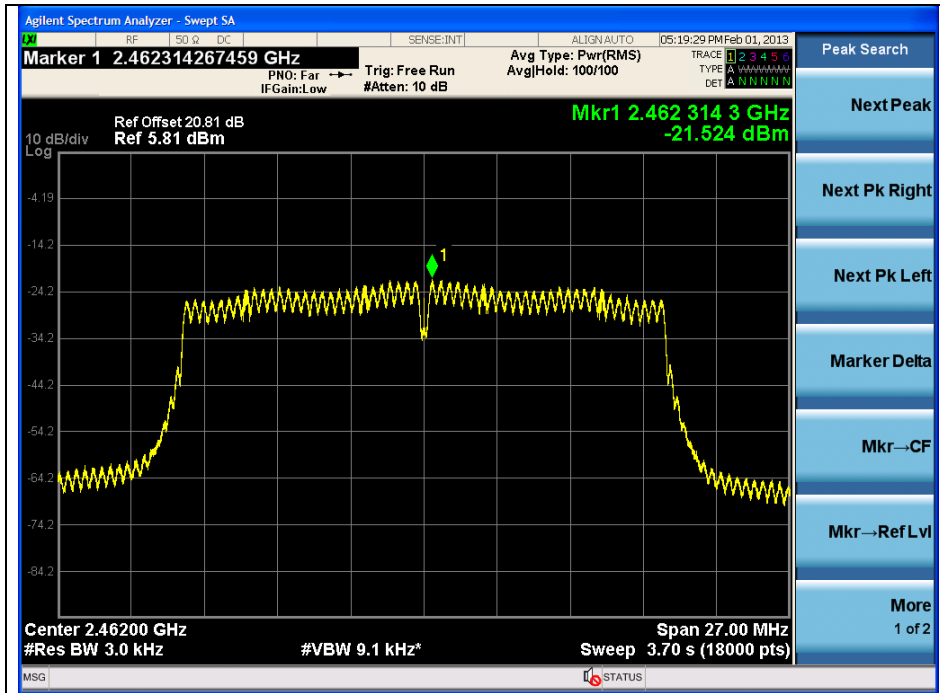

OFDM : 802.11a

Low Channel

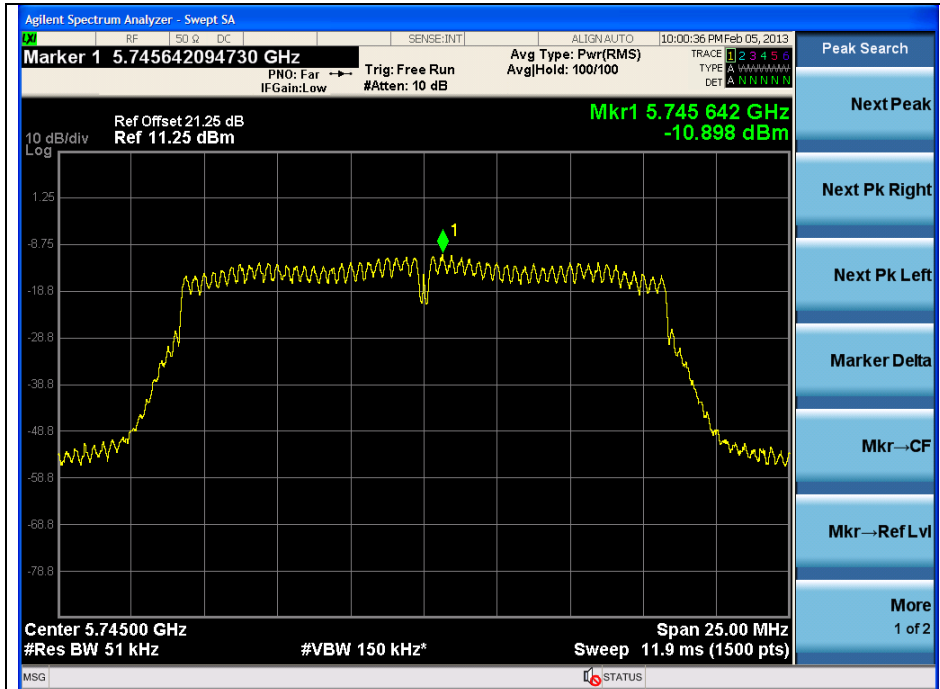

The results shown in this test report refer only to the sample(s) tested unless otherwise stated. This test report cannot be reproduced, except in full, without prior written permission of the Company.

Middle Channel

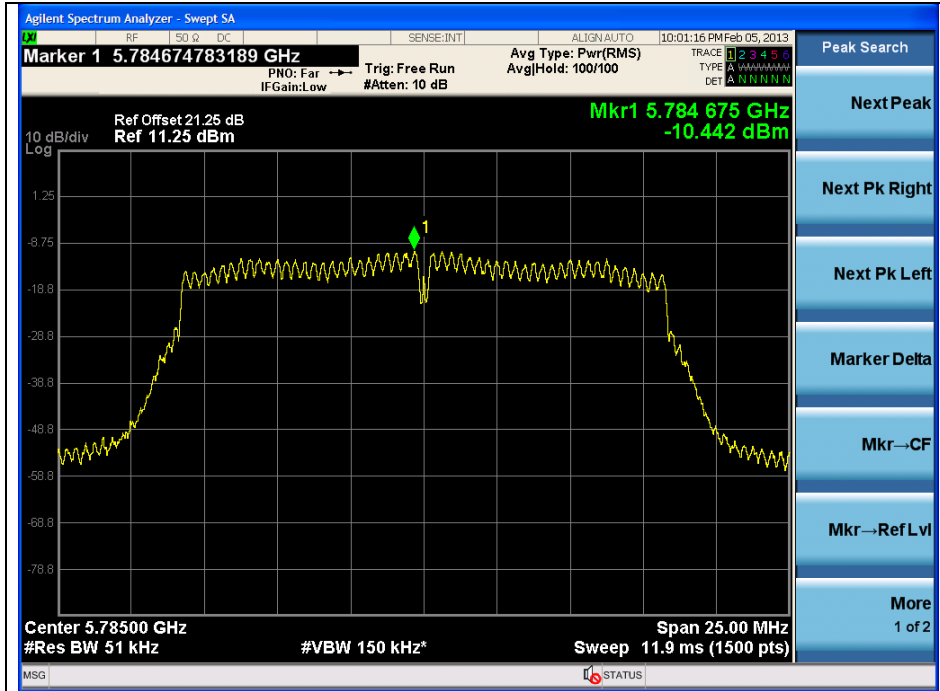

High Channel

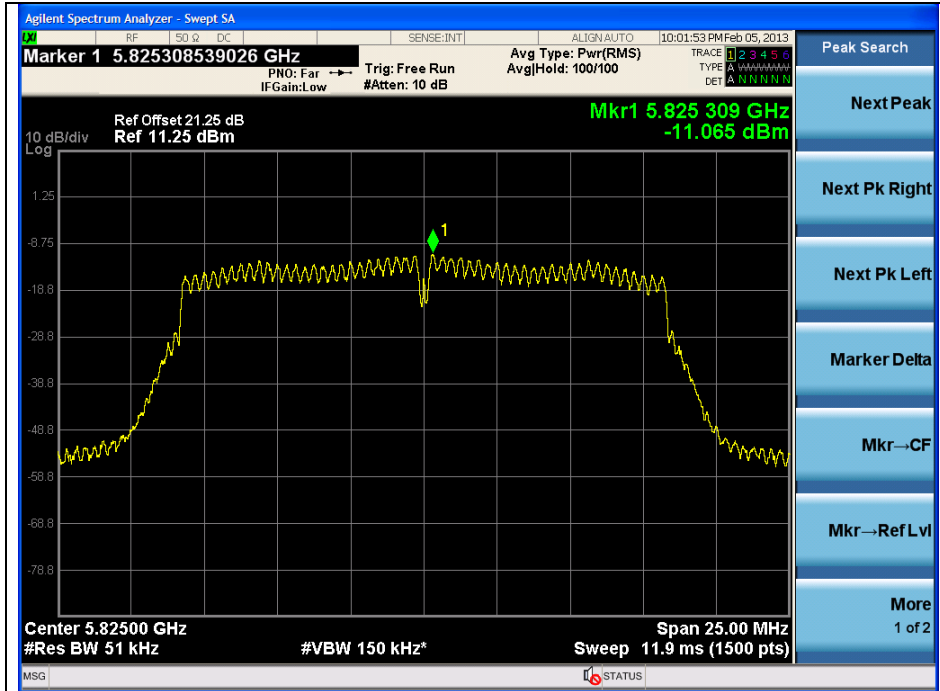

The results shown in this test report refer only to the sample(s) tested unless otherwise stated. This test report cannot be reproduced, except in full, without prior written permission of the Company.

OFDM : 802.11n_HT20

Low Channel

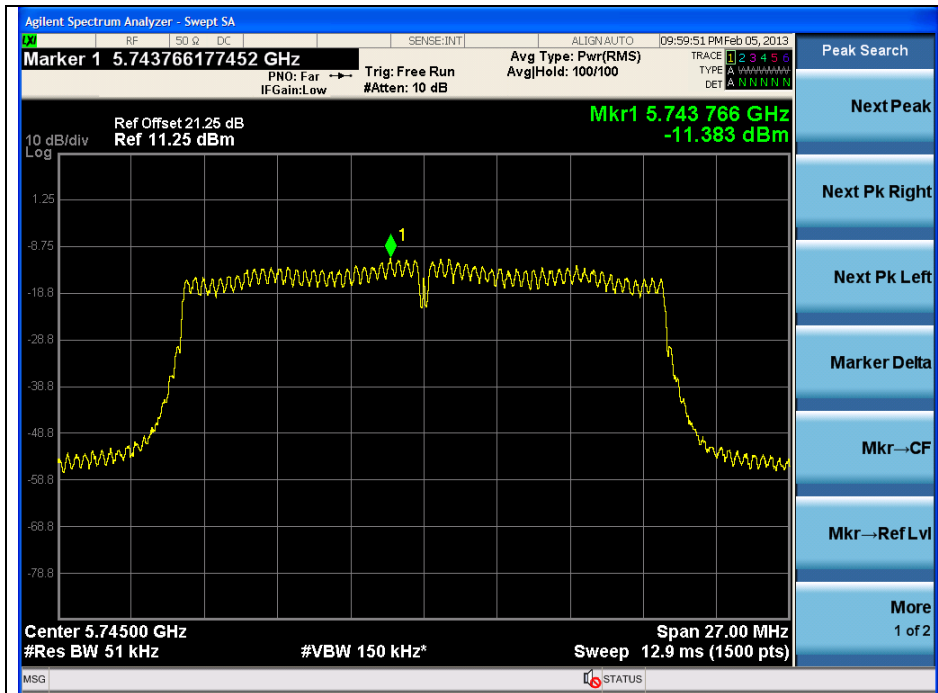

Middle Channel

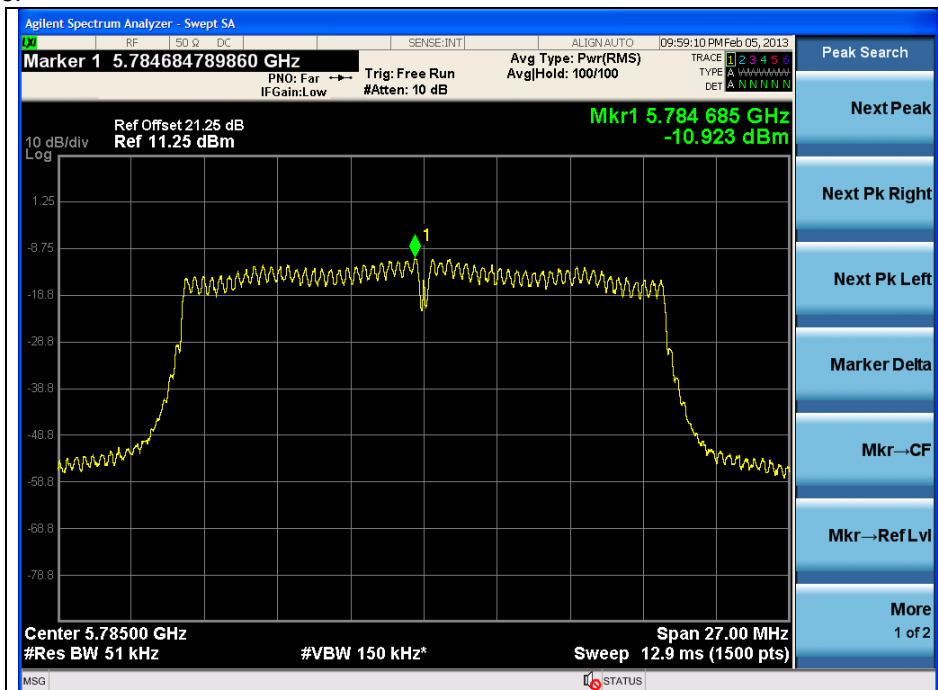

The results shown in this test report refer only to the sample(s) tested unless otherwise stated. This test report cannot be reproduced, except in full, without prior written permission of the Company.

High Channel

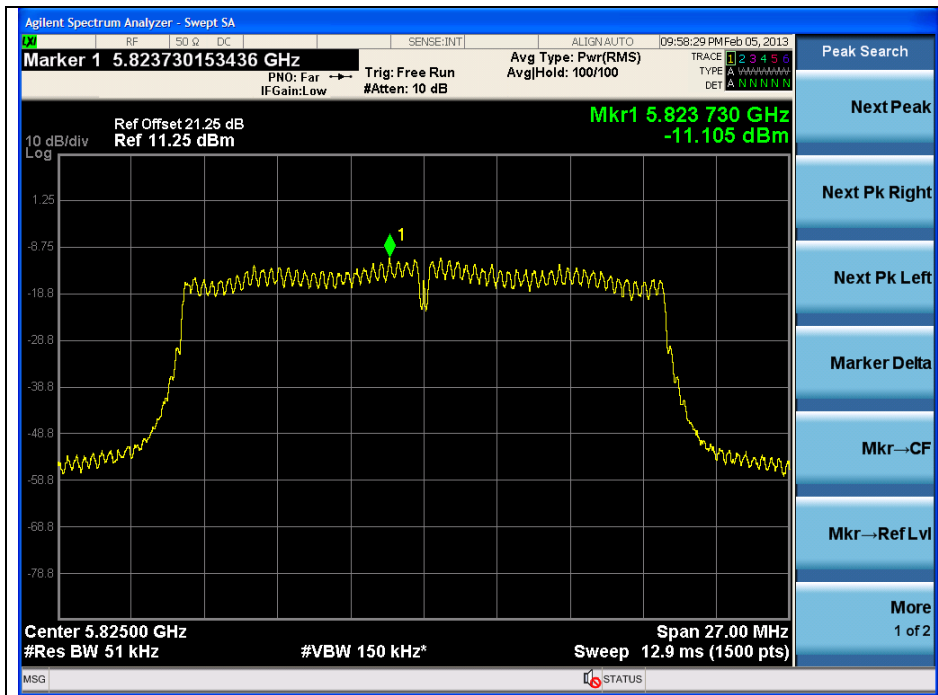

OFDM : 802.11n_HT40

Low Channel

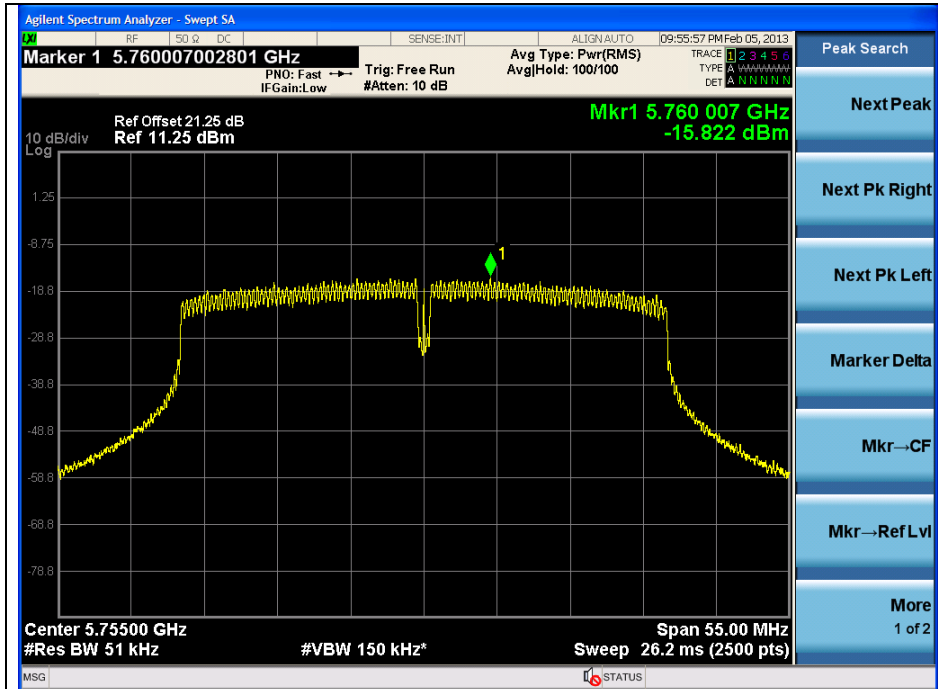

The results shown in this test report refer only to the sample(s) tested unless otherwise stated. This test report cannot be reproduced, except in full, without prior written permission of the Company.

High Channel

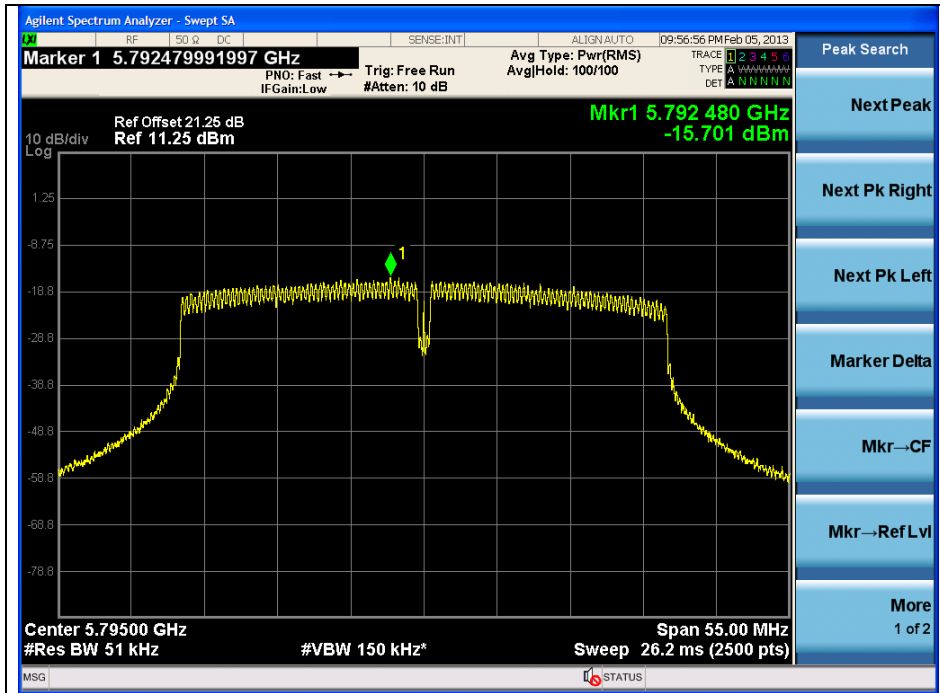

The results shown in this test report refer only to the sample(s) tested unless otherwise stated. This test report cannot be reproduced, except in full, without prior written permission of the Company.

6. Transmitter AC Power Line Conducted Emission

6.1. Test Setup

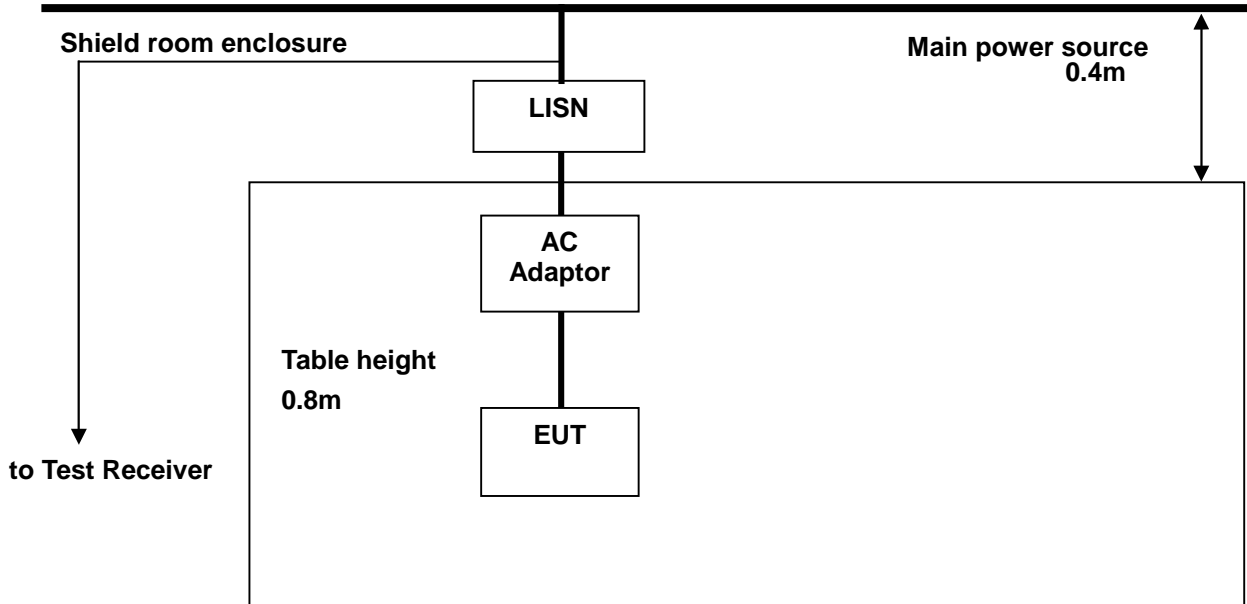

6.2. Limit

According to §15.207(a) for an intentional radiator that is designed to be connected to the public utility (AC) power line, the radio frequency voltage that is conducted back onto the AC power line on any frequency or frequencies, within the band 150 kHz to 30 MHz, shall not exceed the limits in the following table, as measured using a 50 uH/50 ohm line impedance stabilization network(LISN).

Compliance with the provision of this paragraph shall on the measurement of the radio frequency voltage between each power line and ground at the power terminal. The lower applies at the boundary between the frequency ranges.

Frequency of Emission (MHz)	Conducted limit (dB μ V)	
	Quasi-peak	Average
0.15 – 0.50	66 - 56*	56 - 46*
0.50 – 5.00	56	46
5.00 – 30.0	60	50

* Decreases with the logarithm of the frequency.

The results shown in this test report refer only to the sample(s) tested unless otherwise stated. This test report cannot be reproduced, except in full, without prior written permission of the Company.

6.3. Test Procedures

All data rates and modes were investigated for this test. The full data for the worst case data rate are reported in this section.

AC line conducted emissions from the EUT were measured according to the dictates of ANSI C63.10-2009

1. The test procedure is performed in a 6.5m × 3.6m × 3.6m (L × W × H) shielded room. The EUT along with its peripherals were placed on a 1.0 m(W) × 1.5 m(L) and 0.8 m in height wooden table and the EUT was adjusted to maintain a 0.4 meter space from a vertical reference plane.
2. The EUT was connected to power mains through a line impedance stabilization network (LISN) which provides 50 ohm coupling impedance for measuring instrument and the chassis ground was bounded to the horizontal ground plane of shielded room.
3. The excess power cable between the EUT and the LISN was bundled. All connecting cables of EUT were moved to find the maximum emission.

6.4. Test Results (Worst case configuration_11b mode, 1 Mbps, middle channel)

The following table shows the highest levels of conducted emissions on both phase of Hot and Neutral line.

Ambient temperature : (23 ± 2) °C
 Relative humidity : 47 % R.H.

Frequency range : 0.15 MHz – 30 MHz
 Measured Bandwidth : 9 kHz

FREQ. (MHz)	LEVEL(dB μ V)		LINE	LIMIT(dB μ V)		MARGIN(dB)	
	Q-Peak	Average		Q-Peak	Average	Q-Peak	Average
0.51	39.48	31.28	N	56.00	46.00	16.52	14.72
2.12	40.31	33.01	N	56.00	46.00	15.69	12.99
3.35	47.31	40.01	N	56.00	46.00	8.69	5.99
7.53	36.38	27.98	N	60.00	50.00	23.62	22.02
9.01	38.91	30.51	N	60.00	50.00	21.09	19.49
20.85	38.64	28.94	N	60.00	50.00	21.36	21.06
0.44	41.49	33.39	H	57.12	47.12	15.63	13.73
1.07	42.92	32.32	H	56.00	46.00	13.08	13.68
1.64	43.94	34.34	H	56.00	46.00	12.06	11.66
3.33	50.15	41.85	H	56.00	46.00	5.85	4.15
8.30	40.23	30.43	H	60.00	50.00	19.77	19.57
23.63	35.54	25.34	H	60.00	50.00	24.46	24.66

Note ;

1. Line (H): Hot, Line (N): Neutral
2. All modes of operation were investigated and the worst-case emissions are reported using 11b_1Mbps.
3. The limit for Class B device(s) from 150 kHz to 30 MHz are specified in Section of the Title 47 CFR.
4. Traces shown in plot mad using a peak detector and average detector
5. Deviations to the Specifications: None.

The results shown in this test report refer only to the sample(s) tested unless otherwise stated. This test report cannot be reproduced, except in full, without prior written permission of the Company.

Plots of Conducted Power line

Test mode : (Neutral)

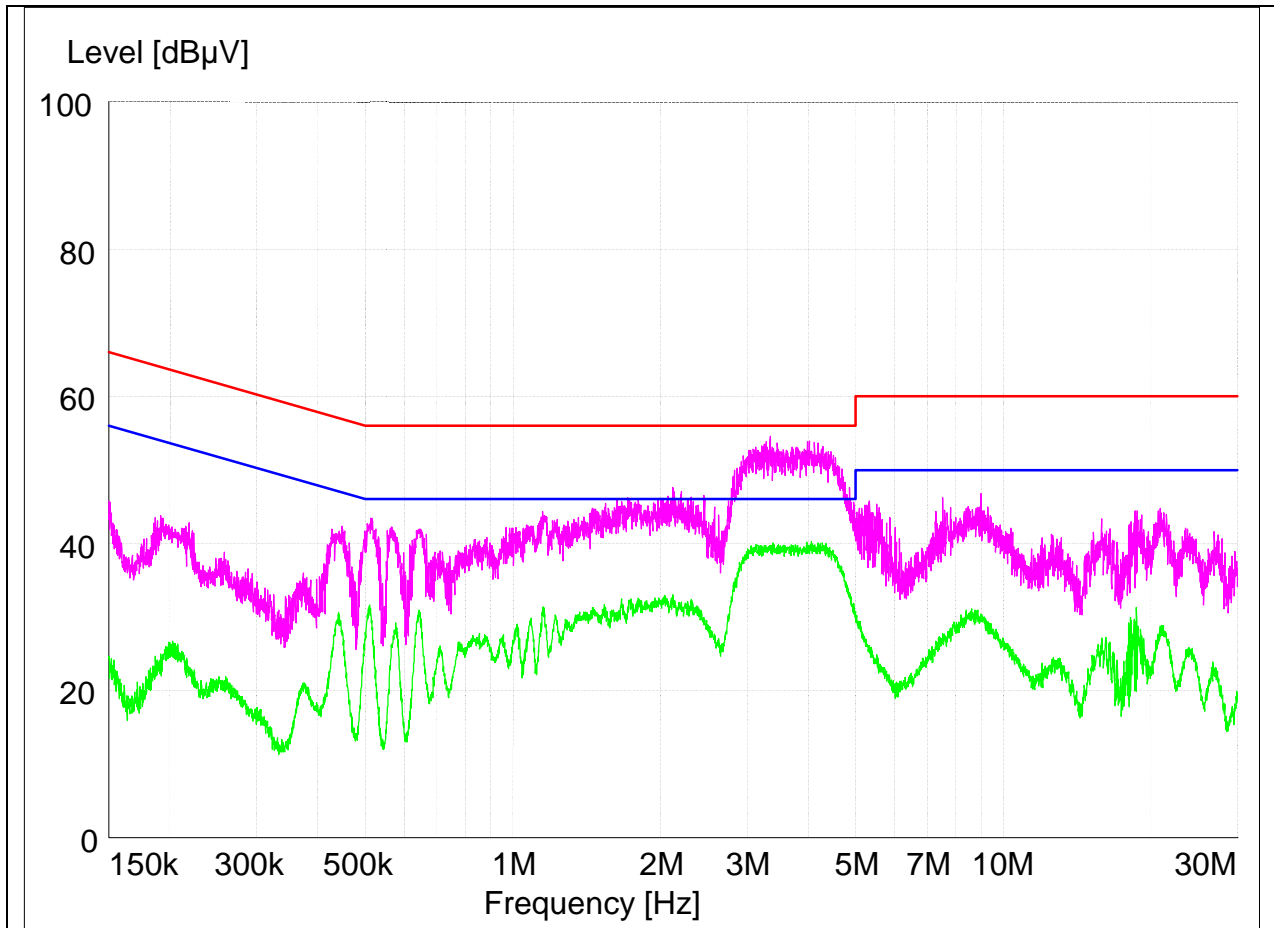

The results shown in this test report refer only to the sample(s) tested unless otherwise stated. This test report cannot be reproduced, except in full, without prior written permission of the Company.

Test mode : (Hot)

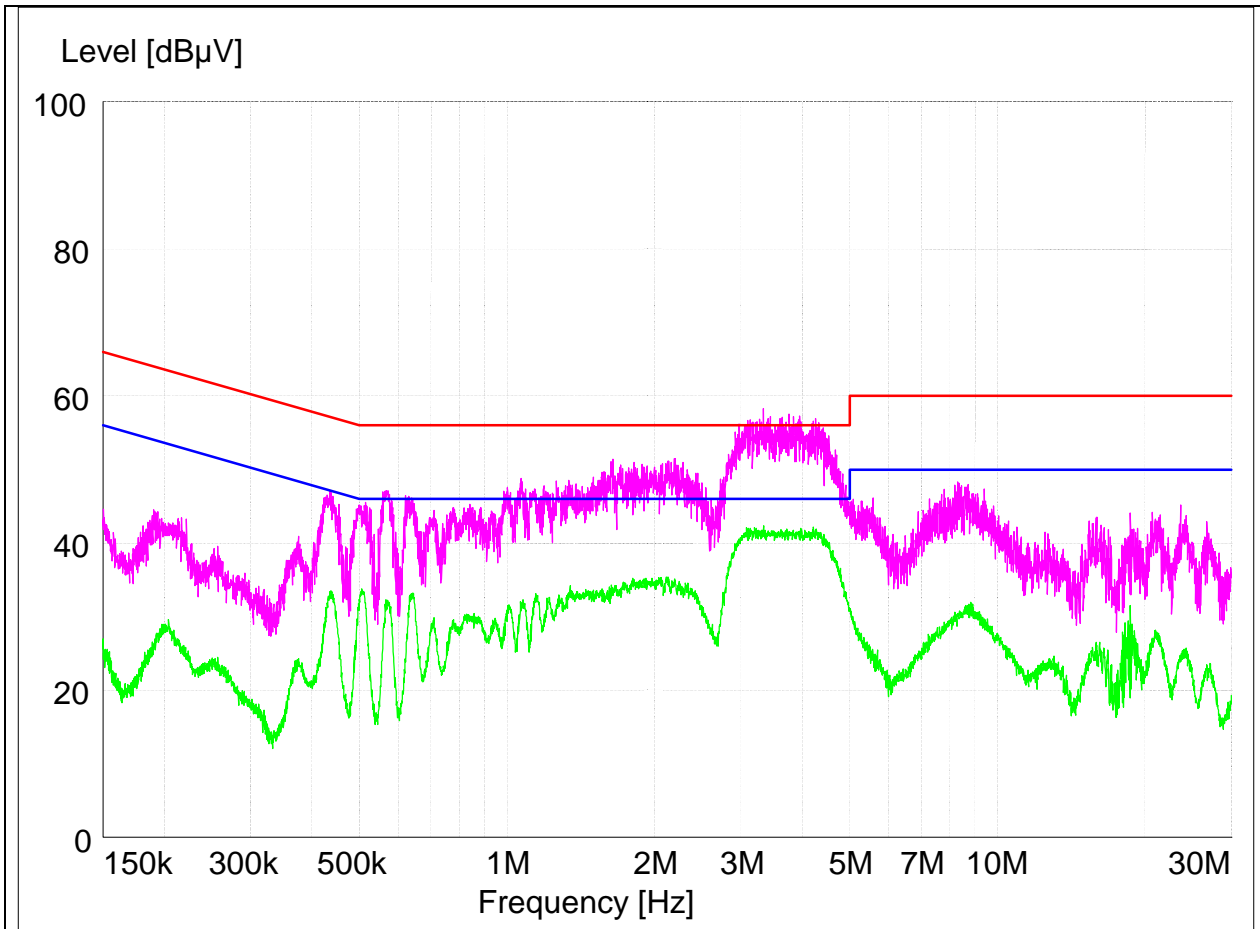

The results shown in this test report refer only to the sample(s) tested unless otherwise stated. This test report cannot be reproduced, except in full, without prior written permission of the Company.

7. Antenna Requirement

7.1. Standard Applicable

For intentional device, according to FCC 47 CFR Section §15.203, an intentional radiator shall be designed to ensure that no antenna other than that furnished by the responsible party shall be used with the device. And according to FCC 47 CFR Section §15.247 (b) if transmitting antennas of directional gain greater than 6 dB i are used, the power shall be reduced by the amount in dB that the gain of the antenna exceeds 6 dB i.

7.2. Antenna Connected Construction

The antenna used of this product is the internal antenna(PIFA) and peak max gain of each antenna as below.

2 412 MHz ~ 2 462 MHz	5 180 MHz ~ 5 320 MHz	5 500 MHz ~ 5 700 MHz	5 745 MHz ~ 5 825 MHz
-2.50 dB i	6.49 dB i	6.44 dB i	6.28 dB i

The results shown in this test report refer only to the sample(s) tested unless otherwise stated. This test report cannot be reproduced, except in full, without prior written permission of the Company.