



SAR EVALUATION REPORT

Applicant Name:
 Samsung Electronics Co., Ltd.
 416, Maetan 3-dong, Yeongtong-gu, Suwon-si
 Gyeonggi-do, 443-742
 Republic of Korea

Date of Testing:
 08/24/12 - 08/27/12 and 10/04/12 - 10/11/12
Test Site/Location:
 PCTEST Lab, Columbia, MD, USA
Document Serial No.:
 OY1210031460-R1.A3L

FCC ID: A3LEKGC100A

APPLICANT: SAMSUNG ELECTRONICS CO., LTD.

EUT Type: Portable Camera
Application Type: Certification
FCC Rule Part(s): CFR §2.1093
Model(s): EK-GC100

Band & Mode	Tx Frequency	Conducted Power [dBm]	Hand SAR (W/kg)	Body SAR (W/kg)	
			10 gram (0 mm)	1 gram (10 mm)	
WCDMA/HSPA 850	826.40 - 846.60 MHz	22.66	0.79	0.36	
WCDMA/HSPA 1900	1852.4 - 1907.6 MHz	22.72	3.15	1.10	
2.4 GHz WLAN	2412 - 2462 MHz	15.63	0.18	0.03	
5.8 GHz WLAN	5745 - 5825 MHz	11.81	0.26	0.21	
5.2 GHz WLAN	5180 - 5240 MHz	11.66	0.39	0.18	
5.3 GHz WLAN	5260 - 5320 MHz	11.68	0.65	0.30	
5.5 GHz WLAN	5500 - 5700 MHz	12.03	0.60	0.39	
Bluetooth	2402 - 2480 MHz	10.53	N/A		
Simultaneous SAR per KDB 690783 D01:				1.12	

Note: Powers in the above table represent output powers for the SAR test configurations and may not represent the highest output powers for all configurations for each mode.

This revised Test Report (S/N: OY1210031460-R1.A3L) supersedes and replaces the previously issued test report on the same subject EUT for the same type of testing as indicated. Please discard or destroy the previously issued test report(s) and dispose of it accordingly.

This wireless portable device has been shown to be capable of compliance for localized specific absorption rate (SAR) for uncontrolled environment/general population exposure limits specified in ANSI/IEEE C95.1-1992 and has been tested in accordance with the measurement procedures specified in FCC/OET Bulletin 65 Supplement C (2001), IEEE 1528-2003 and in applicable Industry Canada Radio Standards Specifications (RSS); for North American frequency bands only.

I attest to the accuracy of data. All measurements reported herein were performed by me or were made under my supervision and are correct to the best of my knowledge and belief. I assume full responsibility for the completeness of these measurements and vouch for the qualifications of all persons taking them. Test results reported herein relate only to the item(s) tested.

PCTEST certifies that no party to this application has been subject to a denial of Federal benefits that includes FCC benefits pursuant to Section 5301 of the Anti-Drug Abuse Act of 1988, 21 U.S.C. 862.

 Randy Ortanez
 President







FCC ID: A3LEKGC100A		SAR EVALUATION REPORT		Reviewed by: Quality Manager
Document S/N: OY1210031460-R1.A3L	Test Dates: 8/24/12 - 8/27/12. 10/04/12 - 10/11/12	EUT Type: Portable Camera	Page 1 of 29	

TABLE OF CONTENTS

1	DEVICE UNDER TEST	3
2	INTRODUCTION	5
3	SAR MEASUREMENT SETUP	6
4	DOSIMETRIC ASSESSMENT	7
5	FCC RF EXPOSURE LIMITS.....	8
6	SAR TESTING PROCEDURES	9
7	FCC MEASUREMENT PROCEDURES.....	10
8	RF CONDUCTED POWERS.....	12
9	SYSTEM VERIFICATION.....	15
10	SAR DATA SUMMARY	17
11	FCC MULTI-TX AND ANTENNA SAR CONSIDERATIONS.....	21
12	EQUIPMENT LIST.....	23
13	MEASUREMENT UNCERTAINTIES	25
14	CONCLUSION.....	27
15	REFERENCES	28

FCC ID: A3LEKGC100A		SAR EVALUATION REPORT		Reviewed by: Quality Manager
Document S/N: 0Y1210031460-R1.A3L	Test Dates: 8/24/12 - 8/27/12. 10/04/12 - 10/11/12	EUT Type: Portable Camera	Page 2 of 29	

1 DEVICE UNDER TEST

1.1 Device Overview

Band & Mode	Tx Frequency
WCDMA/HSPA 850	826.40 - 846.60 MHz
WCDMA/HSPA 1900	1852.4 - 1907.6 MHz
2.4 GHz WLAN	2412 - 2462 MHz
5.8 GHz WLAN	5745 - 5825 MHz
5.2 GHz WLAN	5180 - 5240 MHz
5.3 GHz WLAN	5260 - 5320 MHz
5.5 GHz WLAN	5500 - 5700 MHz
Bluetooth	2402 - 2480 MHz

1.2 EUT Antenna Locations

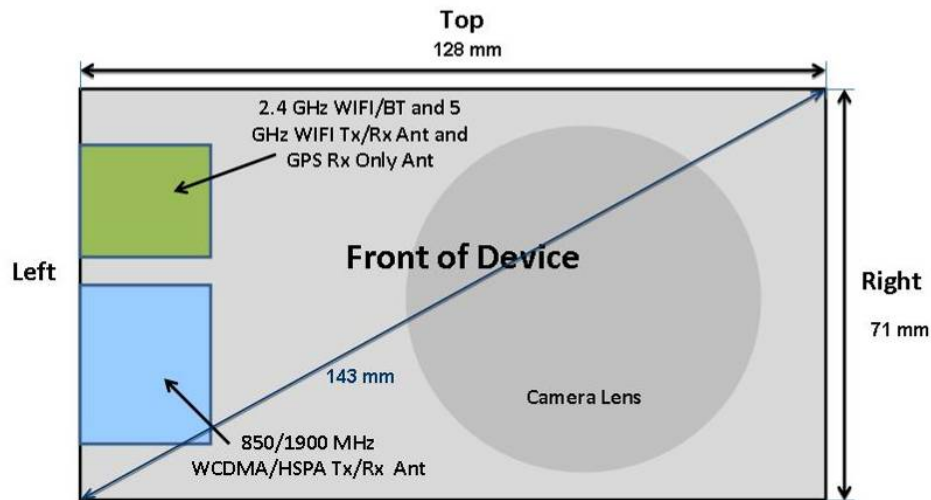

Bottom
Figure 1-1
EUT Antenna Locations

Table 1-1
Sides for SAR Testing

Mode	Back	Front	Top	Bottom	Right	Left
WCDMA 850	Yes	Yes	No	Yes	No	Yes
WCDMA 1900	Yes	Yes	No	Yes	No	Yes
2.4 GHz WLAN	Yes	Yes	Yes	No	No	Yes
5 GHz WLAN	Yes	Yes	Yes	No	No	Yes

Note: Particular EUT edges were not required to be evaluated for SAR if the edges were greater than 2.5 cm from the transmitting antenna according to FCC KDB Publication 941225 D07 guidance, page 1. The antenna document shows the distances between the transmit antennas and the edges of the device.

FCC ID: A3LEKGC100A	PCTEST ENGINEERING LABORATORY, INC.	SAR EVALUATION REPORT		Reviewed by: Quality Manager
Document S/N: 0Y1210031460-R1.A3L	Test Dates: 8/24/12 - 8/27/12. 10/04/12 - 10/11/12	EUT Type: Portable Camera		Page 3 of 29

1.3 SAR Test Exclusions Applied

Head SAR testing was not required for this camera because it does not have an optical viewfinder or a voice receiver which would otherwise allow held-to-face/ear configuration usage. Hand SAR and Body SAR were tested according to the UMPC mini-tablet device procedures in KDB Publication 941225 D07.

(A) WIFI/BT

Since Wireless Router operations are not allowed by the chipset firmware using 5 GHz WIFI, only 2.4 GHz WIFI Hotspot SAR tests and combinations are considered for SAR with respect to Wireless Router configurations in KDB 941225 D06. There are no simultaneous transmission combinations using 5 GHz WIFI.

The separation between the main antenna and the Bluetooth/ WLAN antenna is 6.2 mm.

The average RF Conducted Power of Bluetooth Tx is 11.298 mW (Please refer to the EMC DSS Report for a full set of Bluetooth conducted powers).

2.4 GHz and 5 GHz WIFI and Bluetooth share the same antenna path and cannot transmit simultaneously.

Per KDB Publication 648474, **Bluetooth SAR was not required** based on the maximum conducted power, the Bluetooth/WLAN to main antenna separation distance and Body SAR of the main antenna.

The wireless portable device has been shown to be electrically equivalent to the device of FCC ID: A3LEKGC100 with respect to 2.4 GHz WLAN, 5 GHz WLAN and Bluetooth modes. Previous SAR test data for these modes have been incorporated in this report.

(B) Licensed Transmitter(s)

This device is only capable of QPSK HSUPA in the uplink, but is capable of HSPA+ in the downlink. Therefore, no additional SAR tests are required beyond that described for devices with HSUPA in KDB 941225 D01.

This device does not support any network-based voice services.

1.4 Power Reduction for SAR

There is no power reduction for any band/mode implemented in this device for SAR purposes.



1.5 Guidance Applied

- FCC KDB 941225 (3G, UMPC Devices)
- FCC KDB 248227 (802.11)
- FCC KDB 648474 (Simultaneous)
- FCC KDB 865664 (5 GHz)

1.6 Samples Used for SAR Testing

Several samples were used with identical hardware. The manufacturer has confirmed that the device(s) tested have the same physical, mechanical and thermal characteristics and are within operational tolerances expected for production units.

Band/Mode	Device SN used for Testing
WCDMA/HSPA 850 MHz	S3GC-0001
WCDMA/HSPA 1900 MHz	S3GC-0002
2.4 GHz WLAN	S3GC-0622
5 GHz WLAN	S3GC-0622

FCC ID: A3LEKGC100A	 PCTEST ENGINEERING LABORATORY, INC.	SAR EVALUATION REPORT		Reviewed by: Quality Manager
Document S/N: 0Y1210031460-R1.A3L	Test Dates: 8/24/12 - 8/27/12. 10/04/12 - 10/11/12	EUT Type: Portable Camera		Page 4 of 29

2 INTRODUCTION

The FCC has adopted the guidelines for evaluating the environmental effects of radio frequency (RF) radiation in ET Docket 93-62 on Aug. 6, 1996 to protect the public and workers from the potential hazards of RF emissions due to FCC-regulated portable devices. [1]

The safety limits used for the environmental evaluation measurements are based on the criteria published by the American National Standards Institute (ANSI) for localized specific absorption rate (SAR) in IEEE/ANSI C95.1-1992 Standard for Safety Levels with Respect to Human Exposure to Radio Frequency Electromagnetic Fields, 3 kHz to 300 GHz [3] and Health Canada RF Exposure Guidelines Safety Code 6 [24]. The measurement procedure described in IEEE/ANSI C95.3-2002 Recommended Practice for the Measurement of Potentially Hazardous Electromagnetic Fields - RF and Microwave [4] is used for guidance in measuring the Specific Absorption Rate (SAR) due to the RF radiation exposure from the Equipment Under Test (EUT). These criteria for SAR evaluation are similar to those recommended by the International Committee for Non-Ionizing Radiation Protection (ICNIRP) in "Biological Effects and Exposure Criteria for Radiofrequency Electromagnetic Fields," Report No. Vol 74. SAR is a measure of the rate of energy absorption due to exposure to an RF transmitting source. SAR values have been related to threshold levels for potential biological hazards.

2.1 SAR Definition

Specific Absorption Rate is defined as the time derivative (rate) of the incremental energy (dU) absorbed by (dissipated in) an incremental mass (dm) contained in a volume element (dV) of a given density (ρ). It is also defined as the rate of RF energy absorption per unit mass at a point in an absorbing body (see Equation 2-1).

Equation 2-1
SAR Mathematical Equation

$$SAR = \frac{d}{dt} \left(\frac{dU}{dm} \right) = \frac{d}{dt} \left(\frac{dU}{\rho dV} \right)$$



SAR is expressed in units of Watts per Kilogram (W/kg).

$$SAR = \frac{\sigma \cdot E^2}{\rho}$$

where:

- σ = conductivity of the tissue-simulating material (S/m)
- ρ = mass density of the tissue-simulating material (kg/m^3)
- E = Total RMS electric field strength (V/m)

NOTE: The primary factors that control rate of energy absorption were found to be the wavelength of the incident field in relation to the dimensions and geometry of the irradiated organism, the orientation of the organism in relation to the polarity of field vectors, the presence of reflecting surfaces, and whether conductive contact is made by the organism with a ground plane.[6]

FCC ID: A3LEKGC100A	 PCTEST ENGINEERING LABORATORY, INC.	SAR EVALUATION REPORT		Reviewed by: Quality Manager
Document S/N: 0Y1210031460-R1.A3L	Test Dates: 8/24/12 - 8/27/12. 10/04/12 - 10/11/12	EUT Type: Portable Camera		Page 5 of 29

3 SAR MEASUREMENT SETUP

3.1 Automated SAR Measurement System

Measurements are performed using the DASY automated dosimetric SAR assessment system. The DASY is made by Schmid & Partner Engineering AG (SPEAG) in Zurich, Switzerland and consists of a high precision robotics system (Staubli), robot controller, desktop computer, near-field probe, probe alignment sensor, and the SAM phantom containing the head or body equivalent material. The robot is a six-axis industrial robot, performing precise movements to position the probe to the location (points) of maximum electromagnetic field (EMF). See www.speag.com for more information about the specification of the SAR assessment system.





Figure 3-1
SAR Measurement System



Figure 3-2
Near-Field Probe

Table 3-1
Composition of the Tissue Equivalent Matter

Frequency (MHz)	835	1900	2450	5200-5800
Tissue	Body	Body	Body	Body
Ingredients (% by weight)				
Bactericide	0.1			
DGBE		29.44	26.7	
HEC	1			
NaCl	0.94	0.39	0.1	
Sucrose	44.9			
Polysorbate (Tween) 80				20
Water	53.06	70.17	73.2	80

FCC ID: A3LEKGC100A	 PCTEST ENGINEERING LABORATORY, INC.	SAR EVALUATION REPORT		Reviewed by: Quality Manager
Document S/N: 0Y1210031460-R1.A3L	Test Dates: 8/24/12 - 8/27/12. 10/04/12 - 10/11/12	EUT Type: Portable Camera		Page 6 of 29

4 DOSIMETRIC ASSESSMENT

4.1 Measurement Procedure

The evaluation was performed using the following procedure:

1. The SAR distribution at the exposed side of the head or body was measured at a distance no greater than 5.0 mm from the inner surface of the shell. The area covered the entire dimension of the device-head interface and the horizontal grid resolution was 15mm and 15mm for frequencies < 3 GHz in the x and y directions respectively. When applicable, for frequencies above 3 GHz, a 10 mm by 10 mm resolution was used.
2. The point SAR measurement was taken at the maximum SAR region determined from Step 1 to enable the monitoring of SAR fluctuations/drifts during the 1 gram cube evaluation. SAR at this fixed point was measured and used as a reference value.
3. Based on the area scan data, the peak area of the maximum absorption was determined by spline interpolation. Around this point, a volume of 32mm x 32mm x 30mm (fine resolution volume scan, zoom scan) was assessed by measuring at least 5 x 5 x 7 points. On this basis of this data set, the spatial peak SAR value was evaluated with the following procedure (see references or the DASYS manual online for more details):
 - a. The data was extrapolated to the surface of the outer-shell of the phantom. The combined distance extrapolated was the combined distance from the center of the dipoles 2.7mm away from the tip of the probe housing plus the 1.2 mm distance between the surface and the lowest measuring point. The extrapolation was based on a least-squares algorithm. A polynomial of the fourth order was calculated through the points in the z-axis (normal to the phantom shell).
 - b. After the maximum interpolated values were calculated between the points in the cube, the SAR was averaged over the spatial volume (1g or 10g) using a 3D-Spline interpolation algorithm. The 3D-spline is composed of three one-dimensional splines with the “Not a knot” condition (in x, y, and z directions). The volume was then integrated with the trapezoidal algorithm. One thousand points (10 x 10 x 10) were obtained through interpolation, in order to calculate the averaged SAR.
 - c. All neighboring volumes were evaluated until no neighboring volume with a higher average value was found.
4. The SAR reference value, at the same location as step 2, was re-measured after the zoom scan was complete to calculate the SAR drift. If the drift deviated by more than 5%, the SAR test and drift measurements were repeated.
5. For testing 5 GHz devices, finer resolution zoom scans were performed as specified by FCC SAR Measurement Requirements for 3 – 6 GHz, KDB 865664 publication. The 5 GHz zoom scan requires a minimum volume of 24mm x 24mm x 20mm and 7 x 7 x 11 points.

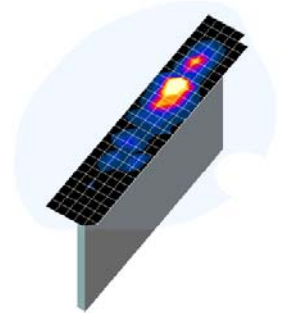



Figure 4-1
Sample SAR Area Scan

FCC ID: A3LEKGC100A	 PCTEST ENGINEERING LABORATORY, INC.	SAR EVALUATION REPORT		Reviewed by: Quality Manager
Document S/N: 0Y1210031460-R1.A3L	Test Dates: 8/24/12 - 8/27/12. 10/04/12 - 10/11/12	EUT Type: Portable Camera		Page 7 of 29

5 FCC RF EXPOSURE LIMITS

5.1 Uncontrolled Environment

UNCONTROLLED ENVIRONMENTS are defined as locations where there is the exposure of individuals who have no knowledge or control of their exposure. The general population/uncontrolled exposure limits are applicable to situations in which the general public may be exposed or in which persons who are exposed as a consequence of their employment may not be made fully aware of the potential for exposure or cannot exercise control over their exposure. Members of the general public would come under this category when exposure is not employment-related; for example, in the case of a wireless transmitter that exposes persons in its vicinity.



5.2 Controlled Environment

CONTROLLED ENVIRONMENTS are defined as locations where there is exposure that may be incurred by persons who are aware of the potential for exposure, (i.e. as a result of employment or occupation). In general, occupational/controlled exposure limits are applicable to situations in which persons are exposed as a consequence of their employment, who have been made fully aware of the potential for exposure and can exercise control over their exposure. This exposure category is also applicable when the exposure is of a transient nature due to incidental passage through a location where the exposure levels may be higher than the general population/uncontrolled limits, but the exposed person is fully aware of the potential for exposure and can exercise control over his or her exposure by leaving the area or by some other appropriate means.

Table 5-1
SAR Human Exposure Specified in ANSI/IEEE C95.1-1992 and Health Canada Safety Code 6

HUMAN EXPOSURE LIMITS		
	UNCONTROLLED ENVIRONMENT <i>General Population</i> (W/kg) or (mW/g)	CONTROLLED ENVIRONMENT <i>Occupational</i> (W/kg) or (mW/g)
SPATIAL PEAK SAR Brain	1.6	8.0
SPATIAL AVERAGE SAR Whole Body	0.08	0.4
SPATIAL PEAK SAR Hands, Feet, Ankles, Wrists	4.0	20

1. The Spatial Peak value of the SAR averaged over any 1 gram of tissue (defined as a tissue volume in the shape of a cube) and over the appropriate averaging time.
2. The Spatial Average value of the SAR averaged over the whole body.
3. The Spatial Peak value of the SAR averaged over any 10 grams of tissue (defined as a tissue volume in the shape of a cube) and over the appropriate averaging time.

FCC ID: A3LEKGC100A	 PCTEST ENGINEERING LABORATORY, INC.	SAR EVALUATION REPORT		Reviewed by: Quality Manager
Document S/N: 0Y1210031460-R1.A3L	Test Dates: 8/24/12 - 8/27/12. 10/04/12 - 10/11/12	EUT Type: Portable Camera		Page 8 of 29

6 SAR TESTING PROCEDURES

6.1 SAR Testing for UMPC Mini-Tablet Device per KDB Publication 941225 D07

Hand-held devices that have transmitting antennas located less than 25 mm from the edge/surface of the device require routine SAR evaluation. Such devices are considered portable, and are designed primarily for interactive hand-held use next to or near the body of a user. Devices are to be setup according to KDB publication 941225 D07 requirements and are configured with maximum output power during SAR assessment for a worst-case SAR evaluation.



Per KDB Publication 941225 D07, SAR testing applies for the device edges with antennas located within 25 mm of each device edge closest to the user. A test separation distance of 10 mm may be considered for 1-g SAR, with the addition of 10-g SAR measurement at 0 mm test separation distance for all 1-g SAR configurations to address hand exposure.

6.2 Power Reduction for SAR

There is no power reduction for any band/mode implemented in this device for SAR purposes.

6.3 Wireless Router Configurations

When the user enables the personal wireless router functions for the device, actual operations include simultaneous transmission of both the WIFI transmitter and another licensed transmitter. Both transmitters often do not transmit at the same transmitting frequency and thus cannot be evaluated for SAR under actual use conditions. Therefore, SAR must be evaluated for each frequency transmission and mode separately and summed with the WIFI transmitter according to KDB 648474 publication procedures. The "Portable Hotspot" feature on the device was NOT activated, to ensure the SAR measurements were evaluated for a single transmission frequency RF signal.

FCC ID: A3LEKGC100A	 PCTEST ENGINEERING LABORATORY, INC.	SAR EVALUATION REPORT		Reviewed by: Quality Manager
Document S/N: 0Y1210031460-R1.A3L	Test Dates: 8/24/12 - 8/27/12. 10/04/12 - 10/11/12	EUT Type: Portable Camera		Page 9 of 29

7 FCC MEASUREMENT PROCEDURES

Power measurements were performed using a base station simulator under digital average power.

7.1 Procedures Used to Establish RF Signal for SAR

The following procedures are according to FCC KDB Publication 941225 D01 "SAR Measurement Procedures for 3G Devices" v02, October 2007.

The device was placed into simulated data transfer using a base station simulator in a RF shielded chamber. Establishing connections in this manner ensure a consistent means for testing SAR and are recommended for evaluating SAR [4]. Devices under test were evaluated prior to testing, with a fully charged battery and were configured to operate at maximum output power. In order to verify that the device was tested throughout the SAR test at maximum output power, the SAR measurement system measures a "point SAR" at an arbitrary reference point at the start and end of the 1 gram/10 gram SAR evaluation, to assess for any power drifts during the evaluation. If the power drift deviated by more than 5%, the SAR test and drift measurements were repeated.

7.2 SAR Measurement Conditions for WCDMA

7.2.1 Output Power Verification

Maximum output power is measured on the High, Middle and Low channels for each applicable transmission band according to the general descriptions in section 5.2 of 3GPP TS 34.121, using the appropriate RMC or AMR with TPC (transmit power control) set to all "1s".

Maximum output power is verified on the High, Middle and Low channels according to the general descriptions in section 5.2 of 3GPP TS 34.121 (release 5), using the appropriate RMC with TPC (transmit power control) set to all "1s". Results for all applicable physical channel configurations (DPCCH, DPDCHn and spreading codes, HS-DPCCH) are tabulated in the test report. All configurations that are not supported by the EUT or cannot be measured due to technical or equipment limitations is identified.

7.2.2 Body SAR Measurements



SAR for body exposure configurations is measured using the 12.2 kbps RMC with the TPC bits all "1s".

7.2.3 Procedures Used to Establish RF Signal for SAR HSDPA Data Devices

The following procedures are applicable to HSDPA data devices operating under 3GPP Release 5. Body exposure conditions are typically applicable to these devices, including handsets and data modems operating in various electronic devices. HSDPA operates in conjunction with WCDMA and requires an active DPCCH. The default test configuration is to measure SAR in WCDMA without HSDPA, with an established radio link between the EUT and a communication test set with 12.2 kbps RMC mode configured in Test Loop Mode 1; and tested with HSDPA with FRC and a 12.2 kbps RMC using the highest SAR configuration in WCDMA. SAR is selectively confirmed for other physical channel configurations according to output power, exposure conditions and device operating capabilities. Maximum output power is verified according to 3GPP TS 23.121 (Release 5) and SAR must be measured according to these maximum output conditions.

7.2.4 SAR Measurement Conditions for HSUPA Data Devices

SAR for body exposure configurations are measured according to the 'Body SAR Measurements' procedures in the 'WCDMA Handsets' section of the KDB 941225 D01 FCC 3G document. In addition, Body SAR is also measured for HSPA when the maximum average output of each RF channel with HSPA active is at least ¼ dB higher of that measured without HSPA in 12.2 kbps RMC mode or the maximum SAR for 12.2 kbps RMC is above 75% of the SAR limit. Body SAR for HSPA is measured with E-DCH Sub-test 5, using H-Set 1 and QPSK for FRC and a 12.2 kbps RMC configured in Test Loop Mode 1 with power control algorithm 2, according to the highest body SAR configuration in 12.2 kbps RMC without HSPA.

FCC ID: A3LEKGC100A	 PCTEST ENGINEERING LABORATORY, INC.	SAR EVALUATION REPORT		Reviewed by: Quality Manager
Document S/N: 0Y1210031460-R1.A3L	Test Dates: 8/24/12 - 8/27/12. 10/04/12 - 10/11/12	EUT Type: Portable Camera		Page 10 of 29

Due to inner loop power control requirements in HSPA, a commercial communication test set should be used for the output power and SAR tests. The 12.2 kbps RMC, FRC H-set 1 and EDCH configurations for HSPA should be configured according to the β values indicated below as well as other applicable procedures described in the 'WCDMA Handset' and 'Release 5 HSDPA Data Devices' sections of the FCC 3G document.

Sub-test	β_c	β_d	β_d (SF)	β_c/β_d	$\beta_{18}^{(1)}$	β_{ec}	β_{ed}	β_{ed} (SF)	β_{ed} (codes)	CM ⁽²⁾ (dB)	MPR (dB)	AG ⁽⁴⁾ Index	E-TFCI
1	11/15 ⁽³⁾	15/15 ⁽³⁾	64	11/15 ⁽³⁾	22/15	209/225	1039/225	4	1	1.0	0.0	20	75
2	6/15	15/15	64	6/15	12/15	12/15	94/75	4	1	3.0	2.0	12	67
3	15/15	9/15	64	15/9	30/15	30/15	β_{ed} : 47/15 β_{ed} : 47/15	4	2	2.0	1.0	15	92
4	2/15	15/15	64	2/15	4/15	2/15	56/75	4	1	3.0	2.0	17	71
5	15/15 ⁽⁴⁾	15/15 ⁽⁴⁾	64	15/15 ⁽⁴⁾	30/15	24/15	134/15	4	1	1.0	0.0	21	81

Note 1: Δ_{ACK} , Δ_{NACK} and $\Delta_{CQI} = 8 \Leftrightarrow A_{18} = \beta_{18}/\beta_c = 30/15 \Leftrightarrow \beta_{18} = 30/15 * \beta_c$.
 Note 2: CM = 1 for $\beta_c/\beta_d = 12/15$, $\beta_{18}/\beta_c = 24/15$. For all other combinations of DPDCH, DPCCH, HS-DPCCH, E-DPDCH and E-DPCCH the MPR is based on the relative CM difference.
 Note 3: For subtest 1 the β_c/β_d ratio of 11/15 for the TFC during the measurement period (TF1, TF0) is achieved by setting the signaled gain factors for the reference TFC (TF1, TF1) to $\beta_c = 10/15$ and $\beta_d = 15/15$.
 Note 4: For subtest 5 the β_c/β_d ratio of 15/15 for the TFC during the measurement period (TF1, TF0) is achieved by setting the signaled gain factors for the reference TFC (TF1, TF1) to $\beta_c = 14/15$ and $\beta_d = 15/15$.
 Note 5: Testing UE using E-DPDCH Physical Layer category 1 Sub-test 3 is not required according to TS 25.306 Table 5.1g.
 Note 6: β_{ed} can not be set directly; it is set by Absolute Grant Value.

7.3 SAR Testing with 802.11 Transmitters

Normal network operating configurations are not suitable for measuring the SAR of 802.11 a/b/g/n transmitters. Unpredictable fluctuations in network traffic and antenna diversity conditions can introduce undesirable variations in SAR results. The SAR for these devices should be measured using chipset based test mode software to ensure the results are consistent and reliable. See KDB Publication 248227 for more details.

7.3.1 General Device Setup



Chipset based test mode software is hardware dependent and generally varies among manufacturers. The device operating parameters established in test mode for SAR measurements must be identical to those programmed in production units, including output power levels, amplifier gain settings and other RF performance tuning parameters. The test frequencies should correspond to actual channel frequencies defined for domestic use. SAR for devices with switched diversity should be measured with only one antenna transmitting at a time during each SAR measurement, according to a fixed modulation and data rate. The same data pattern should be used for all measurements.

7.3.2 Frequency Channel Configurations [27]

For 2.4 GHz, the highest average RF output power channel between the low, mid and high channel at the lowest data rate was selected for SAR evaluation in 802.11b mode. 802.11g/n modes and higher data rates for 802.11b were additionally evaluated for SAR if the output power of the respective mode was 0.25 dB or higher than the powers of the SAR configurations tested in the 802.11b mode.

For 5 GHz, the highest average RF output power channel across the default test channels at the lowest data rate was selected for SAR evaluation in 802.11a. When the adjacent channels are higher in power than the default channels, these "required channels" were considered instead of the default channels for SAR testing. 802.11n modes and higher data rates for 802.11a/n were evaluated only if the respective mode was 0.25 dB or higher than the 802.11a mode.

If the maximum extrapolated peak SAR of the zoom scan for the highest output channel was less than 1.6 W/kg or if the 1g averaged SAR was less than 0.8 W/kg, SAR testing was not required for the other test channels in the band.

FCC ID: A3LEKGC100A	 PCTEST ENGINEERING LABORATORY, INC.	SAR EVALUATION REPORT		Reviewed by: Quality Manager
Document S/N: 0Y1210031460-R1.A3L	Test Dates: 8/24/12 - 8/27/12. 10/04/12 - 10/11/12	EUT Type: Portable Camera		Page 11 of 29

8 RF CONDUCTED POWERS

8.1 UMTS Conducted Powers

3GPP Release Version	Mode	3GPP 34.121 Subtest	Cellular Band [dBm]			PCS Band [dBm]			MPR 3GPP [dB]
			4132	4183	4233	9262	9400	9538	
99	WCDMA	12.2 kbps RMC	22.85	22.66	22.71	22.39	22.54	22.67	-
6	HSDPA	Subtest 1	22.84	22.71	22.67	22.37	22.57	22.72	0
6		Subtest 2	22.60	22.50	22.45	22.13	22.38	22.47	0
6		Subtest 3	22.10	22.22	22.19	21.84	22.06	22.23	0.5
6		Subtest 4	22.07	21.98	21.99	21.61	21.78	21.97	0.5
6	HSUPA	Subtest 1	22.10	21.97	21.99	21.60	21.76	21.93	0
6		Subtest 2	20.67	20.61	20.60	20.25	20.41	20.85	2
6		Subtest 3	21.70	21.65	21.62	21.27	21.39	21.52	1
6		Subtest 4	20.86	20.79	20.72	20.43	20.61	20.74	2
6		Subtest 5	21.73	21.59	21.55	21.22	21.36	21.54	0

UMTS SAR was tested under RMC 12.2 kbps with HSPA Inactive per KDB Publication 941225 D01. HSPA SAR was required since the RMC measured SAR was more than 75% of the SAR limit. HSPA SAR was evaluated using HSUPA Subtest 1 for the channel and configuration that produced the highest measured SAR for RMC.

It is expected by the manufacturer that MPR for some HSUPA subtests may be up to 2 dB more than specified by 3GPP, but also as low as 0 dB according to the chipset implementation in this model. Detailed information is included in the operational description explaining how the MPR is applied for this model.



Figure 8-1
Power Measurement Setup

8.2 WLAN Conducted Powers

Table 8-1
IEEE 802.11b Average RF Power

Mode	Freq [MHz]	Channel	Conducted Power [dBm]			
			Data Rate [Mbps]			
			1	2	5.5	11
802.11b	2412	1	15.31	15.32	15.41	15.37
802.11b	2437	6	15.58	15.60	15.63	15.61
802.11b	2462	11	15.63	15.66	15.68	15.71

Table 8-2
IEEE 802.11g Average RF Power

Mode	Freq [MHz]	Channel	Conducted Power [dBm]							
			Data Rate [Mbps]							
			6	9	12	18	24	36	48	54
802.11g	2412	1	12.20	12.19	12.20	12.20	12.25	12.29	12.23	12.31
802.11g	2437	6	12.40	12.42	12.42	12.43	12.51	12.49	12.47	12.44
802.11g	2462	11	12.50	12.49	12.51	12.57	12.50	12.57	12.49	12.64

Table 8-3
IEEE 802.11n Average RF Power

Mode	Freq [MHz]	Channel	Conducted Power [dBm]							
			Data Rate [Mbps]							
			6.5	13	20	26	39	52	58	65
802.11n	2412	1	12.06	12.04	12.07	12.14	12.10	12.14	12.14	12.19
802.11n	2437	6	12.32	12.27	12.32	12.29	12.22	12.35	12.33	12.31
802.11n	2462	11	12.33	12.33	12.47	12.43	12.42	12.39	12.48	12.50

FCC ID: A3LEKGC100A	PCTEST ENGINEERING LABORATORY, INC.	SAR EVALUATION REPORT		Reviewed by: Quality Manager
Document S/N: 0Y1210031460-R1.A3L	Test Dates: 8/24/12 - 8/27/12. 10/04/12 - 10/11/12	EUT Type: Portable Camera		Page 12 of 29

**Table 8-4
IEEE 802.11a Average RF Power**

Mode	Freq [MHz]	Channel	Conducted Power [dBm]							
			Data Rate [Mbps]							
			6	9	12	18	24	36	48	54
802.11a	5180	36*	11.58	11.63	11.67	11.67	11.69	11.72	11.79	11.79
802.11a	5200	40	11.66	11.65	11.68	11.72	11.69	11.69	11.70	11.66
802.11a	5220	44	11.66	11.69	11.59	11.63	11.72	11.70	11.75	11.76
802.11a	5240	48*	11.63	11.63	11.66	11.70	11.77	11.71	11.74	11.75
802.11a	5260	52*	11.67	11.64	11.66	11.68	11.76	11.71	11.85	11.77
802.11a	5280	56	11.66	11.68	11.70	11.69	11.71	11.73	11.79	11.74
802.11a	5300	60	11.65	11.75	11.66	11.66	11.78	11.78	11.74	11.84
802.11a	5320	64*	11.68	11.74	11.66	11.64	11.68	11.72	11.72	11.73
802.11a	5500	100	11.97	11.99	12.02	12.03	11.98	12.07	12.04	12.16
802.11a	5520	104*	12.03	11.97	11.97	12.02	12.03	12.04	12.10	12.14
802.11a	5540	108	11.96	11.91	11.90	12.04	12.09	11.90	12.08	12.08
802.11a	5560	112	11.87	11.99	11.95	11.98	12.02	12.11	12.02	11.99
802.11a	5580	116*	11.94	11.96	11.92	11.93	11.98	12.11	12.08	12.05
802.11a	5600	120	N/A	N/A	N/A	N/A	N/A	N/A	N/A	N/A
802.11a	5620	124	N/A	N/A	N/A	N/A	N/A	N/A	N/A	N/A
802.11a	5640	128	N/A	N/A	N/A	N/A	N/A	N/A	N/A	N/A
802.11a	5660	132	11.86	11.87	11.90	11.90	11.92	11.96	11.92	11.99
802.11a	5680	136*	11.88	11.87	11.89	11.79	11.89	11.94	11.94	11.95
802.11a	5700	140	11.82	11.86	11.86	11.91	11.86	11.92	11.94	11.99
802.11a	5745	149*	11.73	11.74	11.82	11.77	11.91	11.84	11.91	11.90
802.11a	5765	153	11.70	11.78	11.75	11.80	11.72	11.76	11.78	11.85
802.11a	5785	157*	11.81	11.65	11.70	11.77	11.71	11.81	11.77	11.77
802.11a	5805	161*	11.62	11.66	11.69	11.69	11.72	11.71	11.74	11.80
802.11a	5825	165	11.73	11.69	11.63	11.76	11.66	11.74	11.70	11.80

Per FCC KDB Publication 443999 and RSS-210 A9.2(3), transmission on channels which overlap the 5600-5650 MHz is prohibited as a client. This device does not transmit any beacons or initiate any transmissions in 5.3 and 5.5 GHz Band. (*) – indicates default channels per KDB Publication 248227. When the adjacent channels are higher in power than the default channels, these “required channels” are considered instead of the default channels for SAR testing.

**Table 8-5
IEEE 802.11n (20 MHz Bandwidth) Average RF Power**

Mode	Freq [MHz]	Channel	802.11n (20 MHz Bandwidth) Conducted Power [dBm]							
			Data Rate [Mbps]							
			6.5	13	20	26	39	52	58	65
802.11n	5180	36*	11.48	11.48	11.50	11.62	11.54	11.60	11.61	11.53
802.11n	5200	40	11.53	11.58	11.53	11.56	11.64	11.66	11.60	11.64
802.11n	5220	44	11.51	11.46	11.52	11.55	11.61	11.69	11.66	11.60
802.11n	5240	48*	11.44	11.58	11.61	11.60	11.59	11.64	11.71	11.73
802.11n	5260	52*	11.52	11.51	11.57	11.63	11.65	11.62	11.66	11.76
802.11n	5280	56	11.59	11.65	11.62	11.66	11.66	11.67	11.74	11.63
802.11n	5300	60	11.52	11.58	11.52	11.62	11.62	11.70	11.69	11.64
802.11n	5320	64*	11.56	11.57	11.61	11.60	11.65	11.64	11.62	11.70
802.11n	5500	100	11.90	11.90	11.97	11.98	11.99	11.98	12.04	12.06
802.11n	5520	104*	11.85	11.92	11.90	11.98	11.98	11.95	11.97	12.03
802.11n	5540	108	11.88	11.91	11.95	11.93	11.89	11.92	11.93	11.94
802.11n	5560	112	11.82	11.89	11.89	11.89	11.93	11.96	11.96	11.93
802.11n	5580	116*	11.93	11.84	11.93	11.86	11.84	11.90	11.97	12.00
802.11n	5600	120	N/A	N/A	N/A	N/A	N/A	N/A	N/A	N/A
802.11n	5620	124	N/A	N/A	N/A	N/A	N/A	N/A	N/A	N/A
802.11n	5640	128	N/A	N/A	N/A	N/A	N/A	N/A	N/A	N/A
802.11n	5660	132	11.76	11.79	11.81	11.84	11.85	11.86	11.86	11.73
802.11n	5680	136*	11.72	11.80	11.72	11.78	11.84	11.90	11.92	11.85
802.11n	5700	140	11.71	11.73	11.72	11.78	11.84	11.79	11.79	11.85
802.11n	5745	149*	11.59	11.70	11.76	11.78	11.71	11.77	11.73	11.81
802.11n	5765	153	11.68	11.69	11.62	11.67	11.69	11.73	11.77	11.72
802.11n	5785	157*	11.59	11.57	11.62	11.61	11.66	11.74	11.70	11.72
802.11n	5805	161*	11.59	11.58	11.59	11.59	11.58	11.68	11.65	11.71
802.11n	5825	165	11.52	11.52	11.56	11.59	11.61	11.63	11.65	11.65

Per FCC KDB Publication 443999 and RSS-210 A9.2(3), transmission on channels which overlap the 5600-5650 MHz is prohibited as a client. This device does not transmit any beacons or initiate any transmissions in 5.3 and 5.5 GHz Bands. (*) – indicates default channels per KDB Publication 248227. When the adjacent channels are higher in power than the default channels, these “required channels” are considered instead of the default channels for SAR testing.



FCC ID: A3LEKGC100A	 PCTEST Engineering Laboratory, Inc.	SAR EVALUATION REPORT		Reviewed by: Quality Manager
Document S/N: 0Y1210031460-R1.A3L	Test Dates: 8/24/12 - 8/27/12. 10/04/12 - 10/11/12	EUT Type: Portable Camera		Page 13 of 29

Table 8-6
IEEE 802.11n (40 MHz Bandwidth) Average RF Power

Mode	Freq [MHz]	Channel	802.11n (40MHz Bandwidth) Conducted Power [dBm]							
			Data Rate [Mbps]							
			13.5/15	27/30	40.5/45	54/60	81/90	108/120	121.5/135	135/150
802.11n	5190	38	11.27	11.28	11.36	11.37	11.41	11.38	11.44	11.39
802.11n	5230	46	11.31	11.34	11.41	11.35	11.52	11.47	11.43	11.39
802.11n	5270	54	11.29	11.32	11.40	11.39	11.38	11.37	11.34	11.32
802.11n	5310	62	11.28	11.36	11.34	11.32	11.42	11.46	11.38	11.31
802.11n	5510	102	10.89	10.91	10.83	10.77	10.88	10.87	10.96	10.89
802.11n	5550	110	10.83	10.88	10.86	10.79	10.87	10.89	10.93	10.90
802.11n	5590	118	N/A	N/A	N/A	N/A	N/A	N/A	N/A	N/A
802.11n	5630	126	N/A	N/A	N/A	N/A	N/A	N/A	N/A	N/A
802.11n	5670	134	10.67	10.77	10.64	10.82	10.71	10.78	10.82	10.76
802.11n	5755	151	11.46	11.50	11.53	11.51	11.48	11.58	11.59	11.61
802.11n	5795	159	11.42	11.47	11.48	11.50	11.46	11.55	11.50	11.44

Per FCC KDB Publication 443999 and RSS-210 A9.2(3), transmission on channels which overlap the 5600-5650 MHz is prohibited as a client. This device does not transmit any beacons or initiate any transmissions in 5.3 and 5.5 GHz Bands.

Justification for reduced test configurations for WIFI channels per KDB Publication 248227 and April 2010 FCC/TCB Meeting Notes:

- For 2.4 GHz, highest average RF output power channel for the lowest data rate for IEEE 802.11b were selected for SAR evaluation. Other IEEE 802.11 modes (including 802.11g/n) were not investigated since the average output powers over all channels and data rates were not more than 0.25 dB higher than the tested channel in the lowest data rate of IEEE 802.11b mode.
- For 5 GHz, highest average RF output power channel for the lowest data rate for IEEE 802.11a were selected for SAR evaluation. Other IEEE 802.11 modes (including 802.11n 20 MHz Bandwidth and 802.11n 40 MHz Bandwidth) were not investigated since the average output powers over all channels and data rates were not more than 0.25 dB higher than the tested channel in the lowest data rate of IEEE 802.11a mode.
- When the maximum extrapolated peak SAR of the zoom scan for the maximum output channel is <1.6 W/kg and the 1g averaged SAR is <0.8 W/kg, SAR testing on other channels is not required. Otherwise, the other default (or corresponding required) test channels were additionally tested using the lowest data rate.
- The bolded data rate and channel above were tested for SAR.



Figure 8-2
Power Measurement Setup

FCC ID: A3LEKGC100A	PCTEST ENGINEERING LABORATORY, INC.	SAR EVALUATION REPORT		Reviewed by: Quality Manager
Document S/N: 0Y1210031460-R1.A3L	Test Dates: 8/24/12 - 8/27/12. 10/04/12 - 10/11/12	EUT Type: Portable Camera		Page 14 of 29

9 SYSTEM VERIFICATION

9.1 Tissue Verification

**Table 9-1
Measured Tissue Properties**

Calibrated for Tests Performed on:	Tissue Type	Tissue Temp During Calibration (C°)	Measured Frequency (MHz)	Measured Conductivity, σ (S/m)	Measured Dielectric Constant, ϵ	TARGET Conductivity, σ (S/m)	TARGET Dielectric Constant, ϵ	% dev σ	% dev ϵ
10/5/2012	835B	23.1	820	0.934	54.51	0.969	55.284	-3.61%	-1.40%
			835	0.977	54.03	0.970	55.200	0.72%	-2.12%
			850	0.988	54.07	0.988	55.154	0.00%	-1.97%
10/4/2012	1900B	22.9	1850	1.522	51.98	1.520	53.300	0.13%	-2.48%
			1880	1.540	52.02	1.520	53.300	1.32%	-2.40%
			1910	1.595	51.72	1.520	53.300	4.93%	-2.96%
10/11/2012	1900B	22.6	1850	1.454	52.72	1.520	53.300	-4.34%	-1.09%
			1880	1.514	52.60	1.520	53.300	-0.39%	-1.31%
			1910	1.537	52.46	1.520	53.300	1.12%	-1.58%
8/24/2012	2450B	23.1	2401	1.920	51.44	1.903	52.765	0.89%	-2.51%
			2450	1.976	51.08	1.950	52.700	1.33%	-3.07%
			2499	2.078	51.02	2.019	52.638	2.92%	-3.07%
08/27/2012	5200B-5800B	24.8	5200	5.092	48.32	5.299	49.014	-3.91%	-1.42%
			5220	5.180	48.15	5.323	48.987	-2.69%	-1.71%
			5320	5.347	47.89	5.439	48.607	-1.69%	-1.48%
			5500	5.563	47.39	5.650	48.580	-1.54%	-2.45%
			5520	5.697	47.30	5.673	48.553	0.42%	-2.58%
			5785	6.123	46.74	5.982	48.242	2.36%	-3.11%
			5800	6.191	46.66	6.000	48.200	3.18%	-3.20%

Note: KDB Publication 450824 was ensured to be applied for probe calibration frequencies greater than or equal to 50 MHz of the EUT frequencies.

The above measured tissue parameters were used in the DASY software to perform interpolation via the DASY software to determine actual dielectric parameters at the test frequencies (per IEEE 1528 6.6.1.2). The SAR test plots may slightly differ from the table above since the DASY software rounds to three significant digits.



Probe calibration used within ± 100 MHz of the test frequency in either 5.725 - 5.85 or 5.47-5.725 GHz is acceptable per KDB Publication 865664 since the design of the SAR probe supports the extended frequency, provided the DASY software version recommended is used for the tests, and the expanded calibration uncertainty ($k=2$) is less than or equal to 15% (See SAR probe calibration certificate for this information). The dielectric and conductivities measured are within 10% and 5% respectively of the target parameters specified in Supplement C 01-01.

9.2 Measurement Procedure for Tissue Verification

- 1) The network analyzer and probe system was configured and calibrated.
- 2) The probe was immersed in the sample which was placed in a nonmetallic container. Trapped air bubbles beneath the flange were minimized by placing the probe at a slight angle.
- 3) The complex admittance with respect to the probe aperture was measured
- 4) The complex relative permittivity ϵ can be calculated from the below equation (Pournaropoulos and Misra):

$$Y = \frac{j2\omega\epsilon_r\epsilon_0}{[\ln(b/a)]^2} \int_a^b \int_a^b \int_0^\pi \cos\phi' \frac{\exp[-j\omega r(\mu_0\epsilon_r\epsilon_0)^{1/2}]}{r} d\phi' d\rho' d\rho$$

where Y is the admittance of the probe in contact with the sample, the primed and unprimed coordinates refer to source and observation points, respectively, $r^2 = \rho^2 + \rho'^2 - 2\rho\rho' \cos\phi'$, ω is the angular frequency, and $j = \sqrt{-1}$.

FCC ID: A3LEKGC100A	 PCTEST ENGINEERING LABORATORY, INC.	SAR EVALUATION REPORT		Reviewed by: Quality Manager
Document S/N: 0Y1210031460-R1.A3L	Test Dates: 8/24/12 - 8/27/12. 10/04/12 - 10/11/12	EUT Type: Portable Camera		Page 15 of 29

9.3 Test System Verification

Prior to assessment, the system is verified to $\pm 10\%$ of the manufacturer SAR measurement on the reference dipole at the time of calibration.

**Table 9-2
System Verification Results**

System Verification TARGET & MEASURED												
Tissue Frequency (MHz)	Tissue Type	Date:	Amb. Temp (°C)	Liquid Temp (°C)	Input Power (W)	Dipole SN	Probe SN	Measured SAR _{1g} (W/kg)	1 W Target SAR _{1g} (W/kg)	1 W Normalized SAR _{1g} (W/kg)	Deviation (%)	
850	Body	10/05/2012	23.8	22.8	0.100	4d119	3022	0.964	9.560	9.640	0.84%	
1900	Body	10/04/2012	24.1	23.0	0.100	5d149	3213	3.920	39.300	39.200	-0.25%	
1900	Body	10/11/2012	23.4	22.0	0.100	5d148	3213	3.830	39.100	38.300	-2.05%	
2450	Body	08/24/2012	23.1	22.9	0.010	797	3561	0.522	50.800	52.200	2.76%	
5200	Body	08/27/2012	24.3	23.4	0.100	1057	3589	7.090	73.400	70.900	-3.41%	
5500	Body	08/27/2012	24.5	23.4	0.100	1057	3589	8.190	78.900	81.900	3.80%	
5800	Body	08/27/2012	24.5	23.6	0.100	1057	3589	7.080	74.300	70.800	-4.71%	

Note: Per KDB Publication 865664, when a reference dipole is not defined within $\pm 100\text{MHz}$ of the test frequency, the system verification may be conducted within $\pm 200\text{ MHz}$ of the center frequency of the measurement frequencies if the SAR probe calibration is valid and the same tissue-equivalent matter is used for verification and test measurements.

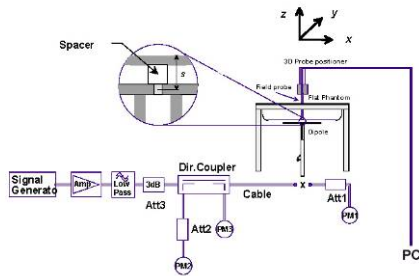

**Figure 9-1
System Verification Setup Diagram**



**Figure 9-2
System Verification Setup Photo**

FCC ID: A3LEKGC100A	PCTEST ENGINEERING LABORATORY, INC.	SAR EVALUATION REPORT		Reviewed by: Quality Manager
Document S/N: 0Y1210031460-R1.A3L	Test Dates: 8/24/12 - 8/27/12. 10/04/12 - 10/11/12	EUT Type: Portable Camera		Page 16 of 29

10 SAR DATA SUMMARY



10.1 Standalone Hand SAR Data

**Table 10-1
Licensed Transmitter Hand SAR Results**

MEASUREMENT RESULTS									
FREQUENCY		Mode	Service	Conducted Power [dBm]	Power Drift [dB]	Spacing	Device Serial Number	Side	SAR (10g)
MHz	Ch.								(W/kg)
836.60	4183	WCDMA 850	RMC	22.66	-0.03	0.0 cm	S3GC-0001	back	0.194
836.60	4183	WCDMA 850	RMC	22.66	-0.05	0.0 cm	S3GC-0001	front	0.420
836.60	4183	WCDMA 850	RMC	22.66	-0.02	0.0 cm	S3GC-0001	bottom	0.209
836.60	4183	WCDMA 850	RMC	22.66	-0.01	0.0 cm	S3GC-0001	left	0.790
1880.00	9400	WCDMA 1900	RMC	22.54	-0.01	0.0 cm	S3GC-0002	back	0.512
1852.40	9262	WCDMA 1900	RMC	22.39	-0.02	0.0 cm	S3GC-0002	front	2.260
1880.00	9400	WCDMA 1900	RMC	22.54	-0.08	0.0 cm	S3GC-0002	front	2.520
1907.60	9538	WCDMA 1900	RMC	22.67	-0.02	0.0 cm	S3GC-0002	front	3.080
1907.60	9538	WCDMA 1900	HSPA	22.72	-0.11	0.0 cm	S3GC-0002	front	3.150
1880.00	9400	WCDMA 1900	RMC	22.54	0.06	0.0 cm	S3GC-0002	bottom	0.445
1852.40	9262	WCDMA 1900	RMC	22.39	0.01	0.0 cm	S3GC-0002	left	1.770
1880.00	9400	WCDMA 1900	RMC	22.54	0.01	0.0 cm	S3GC-0002	left	2.740
1907.60	9538	WCDMA 1900	RMC	22.67	-0.03	0.0 cm	S3GC-0002	left	3.000
ANSI / IEEE C95.1 1992 - SAFETY LIMIT Spatial Peak Uncontrolled Exposure/General Population						Hand 4.0 W/kg (mW/g) averaged over 10 grams			

**Table 10-2
IEEE 802.11b 2.4 GHz WLAN Hand SAR Results**

MEASUREMENT RESULTS										
FREQUENCY		Mode	Service	Conducted Power [dBm]	Power Drift [dB]	Spacing	Device Serial Number	Data Rate (Mbps)	Side	SAR (10g)
MHz	Ch.									(W/kg)
2462	11	IEEE 802.11b	DSSS	15.63	-0.20	0.0 cm	S3GC-0622	1	back	0.017
2462	11	IEEE 802.11b	DSSS	15.63	0.00	0.0 cm	S3GC-0622	1	front	0.083
2462	11	IEEE 802.11b	DSSS	15.63	0.13	0.0 cm	S3GC-0622	1	top	0.030
2462	11	IEEE 802.11b	DSSS	15.63	-0.06	0.0 cm	S3GC-0622	1	left	0.180
ANSI / IEEE C95.1 1992 - SAFETY LIMIT Spatial Peak Uncontrolled Exposure/General Population						Hand 4.0 W/kg (mW/g) averaged over 10 grams				

FCC ID: A3LEKGC100A	 PCTEST ENGINEERING LABORATORY, INC.	SAR EVALUATION REPORT		Reviewed by: Quality Manager
Document S/N: 0Y1210031460-R1.A3L	Test Dates: 8/24/12 - 8/27/12. 10/04/12 - 10/11/12	EUT Type: Portable Camera		Page 17 of 29

**Table 10-3
IEEE 802.11a 5 GHz WLAN Hand SAR Results**

MEASUREMENT RESULTS										
FREQUENCY		Mode	Service	Conducted Power [dBm]	Power Drift [dB]	Spacing	Device Serial Number	Data Rate (Mbps)	Side	SAR (10g)
MHz	Ch.									(W/kg)
5785	157	IEEE 802.11a	OFDM	11.81	0.19	0.0 cm	S3GC-0622	6	back	0.024
5785	157	IEEE 802.11a	OFDM	11.81	-0.07	0.0 cm	S3GC-0622	6	front	0.264
5785	157	IEEE 802.11a	OFDM	11.81	0.12	0.0 cm	S3GC-0622	6	top	0.023
5785	157	IEEE 802.11a	OFDM	11.81	-0.12	0.0 cm	S3GC-0622	6	left	0.255
5220	44	IEEE 802.11a	OFDM	11.66	0.05	0.0 cm	S3GC-0622	6	back	0.036
5220	44	IEEE 802.11a	OFDM	11.66	0.11	0.0 cm	S3GC-0622	6	front	0.118
5220	44	IEEE 802.11a	OFDM	11.66	-0.15	0.0 cm	S3GC-0622	6	top	0.006
5220	44	IEEE 802.11a	OFDM	11.66	-0.01	0.0 cm	S3GC-0622	6	left	0.394
5320	64	IEEE 802.11a	OFDM	11.68	0.14	0.0 cm	S3GC-0622	6	back	0.053
5320	64	IEEE 802.11a	OFDM	11.68	0.04	0.0 cm	S3GC-0622	6	front	0.208
5320	64	IEEE 802.11a	OFDM	11.68	-0.10	0.0 cm	S3GC-0622	6	top	0.010
5320	64	IEEE 802.11a	OFDM	11.68	0.04	0.0 cm	S3GC-0622	6	left	0.649
5520	104	IEEE 802.11a	OFDM	12.03	0.21	0.0 cm	S3GC-0622	6	back	0.054
5520	104	IEEE 802.11a	OFDM	12.03	0.05	0.0 cm	S3GC-0622	6	front	0.384
5520	104	IEEE 802.11a	OFDM	12.03	0.18	0.0 cm	S3GC-0622	6	top	0.017
5520	104	IEEE 802.11a	OFDM	12.03	0.02	0.0 cm	S3GC-0622	6	left	0.601
ANSI / IEEE C95.1 1992 - SAFETY LIMIT Spatial Peak Uncontrolled Exposure/General Population						Hand 4.0 W/kg (mW/g) averaged over 10 grams				

10.2 Body SAR Data at 1 cm per KDB 941225 D07

**Table 10-4
Licensed Transmitter Body SAR Data**

MEASUREMENT RESULTS										
FREQUENCY		Mode	Service	Conducted Power [dBm]	Power Drift [dB]	Spacing	Device Serial Number	Side	SAR (1g)	
MHz	Ch.								(W/kg)	
836.60	4183	WCDMA 850	RMC	22.66	0.02	1.0 cm	S3GC-0001	back	0.180	
836.60	4183	WCDMA 850	RMC	22.66	0.00	1.0 cm	S3GC-0001	front	0.362	
836.60	4183	WCDMA 850	RMC	22.66	-0.04	1.0 cm	S3GC-0001	bottom	0.355	
836.60	4183	WCDMA 850	RMC	22.66	-0.02	1.0 cm	S3GC-0001	left	0.197	
1880.00	9400	WCDMA 1900	RMC	22.54	0.13	1.0 cm	S3GC-0002	back	0.165	
1852.40	9262	WCDMA 1900	RMC	22.39	-0.01	1.0 cm	S3GC-0002	front	0.459	
1880.00	9400	WCDMA 1900	RMC	22.54	0.00	1.0 cm	S3GC-0002	front	0.925	
1907.60	9538	WCDMA 1900	RMC	22.67	0.00	1.0 cm	S3GC-0002	front	1.100	
1880.00	9400	WCDMA 1900	RMC	22.54	0.05	1.0 cm	S3GC-0002	bottom	0.189	
1880.00	9400	WCDMA 1900	RMC	22.54	-0.03	1.0 cm	S3GC-0002	left	0.757	
ANSI / IEEE C95.1 1992 - SAFETY LIMIT Spatial Peak Uncontrolled Exposure/General Population						Body 1.6 W/kg (mW/g) averaged over 1 gram				





FCC ID: A3LEKGC100A	 PCTEST ENGINEERING LABORATORY, INC.	SAR EVALUATION REPORT		Reviewed by: Quality Manager
Document S/N: 0Y1210031460-R1.A3L	Test Dates: 8/24/12 - 8/27/12. 10/04/12 - 10/11/12	EUT Type: Portable Camera		Page 18 of 29

Table 10-5
IEEE 802.11b 2.4 GHz WLAN Body SAR Data

MEASUREMENT RESULTS										
FREQUENCY		Mode	Service	Conducted Power [dBm]	Power Drift [dB]	Spacing	Device Serial Number	Data Rate (Mbps)	Side	SAR (1g)
MHz	Ch.									(W/kg)
2462	11	IEEE 802.11b	DSSS	15.63	0.19	1.0 cm	S3GC-0622	1	back	0.011
2462	11	IEEE 802.11b	DSSS	15.63	-0.20	1.0 cm	S3GC-0622	1	front	0.017
2462	11	IEEE 802.11b	DSSS	15.63	-0.16	1.0 cm	S3GC-0622	1	top	0.008
2462	11	IEEE 802.11b	DSSS	15.63	0.16	1.0 cm	S3GC-0622	1	left	0.028
ANSI / IEEE C95.1 1992 - SAFETY LIMIT						Body				
Spatial Peak						1.6 W/kg (mW/g)				
Uncontrolled Exposure/General Population						averaged over 1 gram				

Table 10-6
IEEE 802.11a 5 GHz WLAN Body SAR Data

MEASUREMENT RESULTS										
FREQUENCY		Mode	Service	Conducted Power [dBm]	Power Drift [dB]	Spacing	Device Serial Number	Data Rate (Mbps)	Side	SAR (1g)
MHz	Ch.									(W/kg)
5785	157	IEEE 802.11a	OFDM	11.81	-0.21	1.0 cm	S3GC-0622	6	back	0.020
5785	157	IEEE 802.11a	OFDM	11.81	0.04	1.0 cm	S3GC-0622	6	front	0.210
5785	157	IEEE 802.11a	OFDM	11.81	0.04	1.0 cm	S3GC-0622	6	top	0.000
5785	157	IEEE 802.11a	OFDM	11.81	0.14	1.0 cm	S3GC-0622	6	left	0.147
5220	44	IEEE 802.11a	OFDM	11.66	0.07	1.0 cm	S3GC-0622	6	back	0.040
5220	44	IEEE 802.11a	OFDM	11.66	-0.07	1.0 cm	S3GC-0622	6	front	0.138
5220	44	IEEE 802.11a	OFDM	11.66	-0.12	1.0 cm	S3GC-0622	6	top	0.000
5220	44	IEEE 802.11a	OFDM	11.66	-0.12	1.0 cm	S3GC-0622	6	left	0.179
5320	64	IEEE 802.11a	OFDM	11.68	-0.21	1.0 cm	S3GC-0622	6	back	0.050
5320	64	IEEE 802.11a	OFDM	11.68	0.18	1.0 cm	S3GC-0622	6	front	0.214
5320	64	IEEE 802.11a	OFDM	11.68	-0.15	1.0 cm	S3GC-0622	6	top	0.000
5320	64	IEEE 802.11a	OFDM	11.68	-0.13	1.0 cm	S3GC-0622	6	left	0.295
5520	104	IEEE 802.11a	OFDM	12.03	-0.17	1.0 cm	S3GC-0622	6	back	0.066
5520	104	IEEE 802.11a	OFDM	12.03	0.13	1.0 cm	S3GC-0622	6	front	0.260
5520	104	IEEE 802.11a	OFDM	12.03	0.04	1.0 cm	S3GC-0622	6	top	0.004
5520	104	IEEE 802.11a	OFDM	12.03	0.15	1.0 cm	S3GC-0622	6	left	0.386
ANSI / IEEE C95.1 1992 - SAFETY LIMIT						Body				
Spatial Peak						1.6 W/kg (mW/g)				
Uncontrolled Exposure/General Population						averaged over 1 gram				

FCC ID: A3LEKGC100A	 PCTEST ENGINEERING LABORATORY, INC.	SAR EVALUATION REPORT		Reviewed by: Quality Manager
Document S/N: OY1210031460-R1.A3L	Test Dates: 8/24/12 - 8/27/12. 10/04/12 - 10/11/12	EUT Type: Portable Camera		Page 19 of 29

10.3 SAR Test Notes

General Notes:



1. The test data reported are the worst-case SAR value with the position set in a typical configuration. Test procedures used were according to KDB Publication 941225 D07.
2. Batteries are fully charged for all readings. The standard battery was used.
3. Tissue parameters and temperatures are listed on the SAR plots.
4. Liquid tissue depth was at least 15.0 cm. To confirm the proper SAR liquid depth, the z-axis plots from the system verifications were included since the system verifications were performed using the same liquid, probe and DAE as the SAR tests in the same time period.
5. All samples tested were electrically identical per the applicant. The manufacturer has confirmed that the device(s) tested have the same physical, mechanical and thermal characteristics and are within operational tolerances expected for production units.
6. Right Edge and Top Edge for the licensed transmitter were not tested since the antenna distance from the edges was greater than 2.5 cm per FCC KDB Publication 941225 D07 guidance (see Section 1.2).
7. Right Edge and Bottom Edge for the WLAN transmitter were not tested since the antenna distance from the edges was greater than 2.5 cm per FCC KDB Publication 941225 D07 (see Section 1.2).
8. During SAR Testing for the Wireless Router conditions per KDB 941225 D06, the actual Portable Hotspot operation (with actual simultaneous transmission of a transmitter with WIFI) was not activated (See Section 6.3.)

UMTS Notes:

1. UMTS SAR was tested under RMC 12.2 kbps with HSPA Inactive per KDB Publication 941225 D01. HSPA SAR was required since the RMC measured SAR was more than 75% of the SAR limit. HSPA SAR was evaluated using HSUPA Subtest 1 for the channel and configuration that produced the highest measured SAR for RMC.
2. Per KDB Publication 648474, if the SAR measured at the middle channel for each test configuration is at least 3.0 dB lower than the SAR limit, testing at the high and low channels is optional for such test configuration(s).

WLAN Notes:

1. Justification for reduced test configurations for WIFI channels per KDB Publication 248227 and April 2010 FCC/TCB Meeting Notes for 2.4 GHz WIFI: Highest average RF output power channel for the lowest data rate was selected for SAR evaluation in 802.11b. Other IEEE 802.11 modes (including 802.11g/n) were not investigated since the average output powers over all channels and data rates were not more than 0.25 dB higher than the tested channel in the lowest data rate of IEEE 802.11b mode.
2. Justification for reduced test configurations for WIFI channels per KDB Publication 248227 and April 2010 FCC/TCB Meeting Notes for 5 GHz WIFI: Highest average RF output power channel for the lowest data rate was selected for SAR evaluation in 802.11a. Other IEEE 802.11 modes (including 802.11n 20 MHz Bandwidth and 802.11n 40 MHz Bandwidth) were not investigated since the average output powers over all channels and data rates were not more than 0.25 dB higher than the tested channel in the lowest data rate of IEEE 802.11a mode.
3. When Hotspot is enabled, all 5 GHz bands are disabled.
4. WLAN transmission was verified using an uncalibrated spectrum analyzer.
5. Since the maximum extrapolated peak SAR of the zoom scan for the maximum output channel was <1.6 W/kg and the 1g averaged SAR was <0.8 W/kg, SAR testing on the other default channels was not required.

FCC ID: A3LEKGC100A	 PCTEST ENGINEERING LABORATORY, INC.	SAR EVALUATION REPORT		Reviewed by: Quality Manager
Document S/N: 0Y1210031460-R1.A3L	Test Dates: 8/24/12 - 8/27/12. 10/04/12 - 10/11/12	EUT Type: Portable Camera		Page 20 of 29

11 FCC MULTI-TX AND ANTENNA SAR CONSIDERATIONS

11.1 Introduction

The following procedures adopted from “FCC SAR Considerations for Cell Phones with Multiple Transmitters” FCC KDB Publication 648474 are applicable to handsets with built-in unlicensed transmitters such as 802.11a/b/g/n and Bluetooth devices which may simultaneously transmit with the licensed transmitter.

11.2 FCC Power Tables & Conditions

	2.45	5.15 - 5.35	5.47 - 5.85	GHz
P_{Ref}	12	6	5	mW
Device output power should be rounded to the nearest mW to compare with values specified in this table.				

Figure 11-1
Output Power Thresholds for Unlicensed Transmitters



	Individual Transmitter	Simultaneous Transmission
Licensed Transmitters	<u>Routine evaluation required</u>	SAR not required: <u>Unlicensed only</u>
Unlicensed Transmitters	<p>When there is no simultaneous transmission –</p> <ul style="list-style-type: none"> output ≤ 60/f: SAR not required output > 60/f: stand-alone SAR required <p>When there is simultaneous transmission – <u>Stand-alone SAR not required when</u></p> <ul style="list-style-type: none"> output $\leq 2 \cdot P_{Ref}$ and antenna is ≥ 5.0 cm from other antennas output $\leq P_{Ref}$ and antenna is ≥ 2.5 cm from other antennas output $\leq P_{Ref}$ and antenna is < 2.5 cm from other antennas, each with either output power $\leq P_{Ref}$ or 1-g SAR < 1.2 W/kg <p><u>Otherwise stand-alone SAR is required</u></p> <p>When stand-alone SAR is required</p> <ul style="list-style-type: none"> test SAR on highest output channel for each wireless mode and exposure condition if SAR for highest output channel is $> 50\%$ of SAR limit, evaluate all channels according to normal procedures 	<ul style="list-style-type: none"> when stand-alone 1-g SAR is not required and antenna is ≥ 5 cm from other antennas <p><u>Licensed & Unlicensed</u></p> <ul style="list-style-type: none"> when the sum of the 1-g SAR is < 1.6 W/kg for all simultaneous transmitting antennas when SAR to peak location separation ratio of simultaneous transmitting antenna pair is < 0.3 <p>SAR required: <u>Licensed & Unlicensed</u></p> <p>antenna pairs with SAR to peak location separation ratio ≥ 0.3; test is only required for the configuration that results in the highest SAR in stand-alone configuration for each wireless mode and exposure condition</p> <p>Note: simultaneous transmission exposure conditions for head and body can be different for different style phones; therefore, different test requirements may apply</p>

Figure 11-2
SAR Evaluation Requirements for Multiple Transmitter Handsets

According to Figure 11-1 and Figure 11-2, simultaneous transmission analysis of SAR may be required for this device for the licensed and unlicensed transmitters. Possible simultaneous transmissions for this device were numerically summed using stand-alone SAR data and are shown in the following tables.

There are no simultaneous transmission combinations using 5 GHz WIFI.

Per KDB Publication 648474, standalone Bluetooth SAR tests were not required. Standalone SAR tests for WLAN were required.

FCC ID: A3LEKGC100A	 PCTEST ENGINEERING LABORATORY, INC.	SAR EVALUATION REPORT		Reviewed by: Quality Manager
Document S/N: 0Y1210031460-R1.A3L	Test Dates: 8/24/12 - 8/27/12. 10/04/12 - 10/11/12	EUT Type: Portable Camera		Page 21 of 29

11.3 Hand SAR (10 gram) Simultaneous Transmission Analysis

Table 11-1
Simultaneous Transmission Scenario (Hand SAR 10 gram at 0.0 cm)

Simult Tx	Configuration	WCDMA 850 SAR (W/kg)	2.4 GHz WLAN SAR (W/kg)	Σ 10g SAR (W/kg)	Σ 10g SAR limit per ANSI/IEEE C95.1-1992 (W/kg)
Hand SAR	Back	0.194	0.017	0.211	4.000
	Front	0.420	0.083	0.503	
	Top	-	0.030	0.030	
	Bottom	0.209	-	0.209	
	Right	-	-	0.000	
	Left	0.790	0.180	0.970	
Simult Tx	Configuration	WCDMA 1900 SAR (W/kg)	2.4 GHz WLAN SAR (W/kg)	Σ 10g SAR (W/kg)	Σ 10g SAR limit per ANSI/IEEE C95.1-1992 (W/kg)
Hand SAR	Back	0.512	0.017	0.529	4.000
	Front	3.150	0.083	3.233	
	Top	-	0.030	0.030	
	Bottom	0.445	-	0.445	
	Right	-	-	0.000	
	Left	3.000	0.180	3.180	

Note: Per FCC KDB Publication 941225 D07, the edges with antennas more than 2.5 cm are not required to be evaluated for SAR (“-”). The above tables represent 10g hand SAR in a portable hotspot condition.

11.4 Body SAR Simultaneous Transmission Analysis

Table 11-2
Simultaneous Transmission Scenario (Body at 1.0 cm)



Simult Tx	Configuration	WCDMA 850 SAR (W/kg)	2.4 GHz WLAN SAR (W/kg)	Σ 1g SAR (W/kg)	Simult Tx	Configuration	WCDMA 1900 SAR (W/kg)	2.4 GHz WLAN SAR (W/kg)	Σ 1g SAR (W/kg)
Body SAR	Back	0.180	0.011	0.191	Body SAR	Back	0.165	0.011	0.176
	Front	0.362	0.017	0.379		Front	1.100	0.017	1.117
	Top	-	0.008	0.008		Top	-	0.008	0.008
	Bottom	0.355	-	0.355		Bottom	0.189	-	0.189
	Right	-	-	0.000		Right	-	-	0.000
	Left	0.197	0.028	0.225		Left	0.757	0.028	0.785

Note: Per FCC KDB Publication 941225 D07, the edges with antennas more than 2.5 cm are not required to be evaluated for SAR (“-”). The above tables represent a portable hotspot condition.

11.5 Simultaneous Transmission Conclusion

The above numerical summed SAR was below the SAR limit. Therefore, the above analysis is sufficient to determine that simultaneous transmission cases will not exceed the SAR limit. No volumetric SAR summation is required per FCC KDB Publication 648474.



It was confirmed that all standalone and simultaneous transmission scenarios remain compliant when extrapolated to the maximum allowed output power.

FCC ID: A3LEKGC100A	 PCTEST ENGINEERING LABORATORY, INC.	SAR EVALUATION REPORT		Reviewed by: Quality Manager
Document S/N: 0Y1210031460-R1.A3L	Test Dates: 8/24/12 - 8/27/12. 10/04/12 - 10/11/12	EUT Type: Portable Camera		Page 22 of 29

12 EQUIPMENT LIST

Applicable for 8/24/12 - 8/27/12:

Manufacturer	Model	Description	Cal Date	Cal Interval	Cal Due	Serial Number
Agilent	8753E	(30kHz-6GHz) Network Analyzer	4/4/2012	Annual	4/4/2013	JP38020182
Agilent	8753E	(30kHz-6GHz) Network Analyzer	4/3/2012	Annual	4/3/2013	US37390350
Agilent	85070E	Dielectric Probe Kit	3/8/2012	Annual	3/8/2013	MY44300633
Agilent	8648D	Signal Generator	4/3/2012	Annual	4/3/2013	3629U00687
Agilent	85047A	S-Parameter Test Set	N/A	N/A	N/A	2904A00579
Amplifier Research	5S1G4	5W, 800MHz-4.2GHz	CBT	N/A	N/A	21910
Anritsu	ML2438A	Power Meter	2/14/2012	Annual	2/14/2013	98150041
Anritsu	ML2495A	Power Meter	10/13/2011	Annual	10/13/2012	1039008
Anritsu	MA2481A	Power Sensor	2/14/2012	Annual	2/14/2013	8013
Anritsu	MA2481A	Power Sensor	4/5/2012	Annual	4/5/2013	5605
Anritsu	MA2481A	Power Sensor	2/14/2012	Annual	2/14/2013	2400
Anritsu	MA2411B	Pulse Sensor	10/13/2011	Annual	10/13/2012	1027293
Anritsu	MT8820C	Radio Communication Tester	11/11/2011	Annual	11/11/2012	6200901190
COMTECH	AR85729-5/5759B	Solid State Amplifier	CBT	N/A	N/A	M3W1A00-1002
COMTECH	AR85729-5	Solid State Amplifier	CBT	N/A	N/A	M1S5A00-009
Control Company	61220-416	Long-Stem Thermometer	2/15/2011	Biennial	2/15/2013	111331332
Gigatronics	80701A	(0.05-18GHz) Power Sensor	10/12/2011	Annual	10/12/2012	1833460
Gigatronics	8651A	Universal Power Meter	10/12/2011	Annual	10/12/2012	8650319
Intelligent Weigh	PD-3000	Electronic Balance	3/27/2012	Annual	3/27/2013	11081534
Intelligent Weighing	PD-3000	Electronic Balance	6/29/2012	Annual	6/29/2013	120405017
MCL	BW-N6W5+	6dB Attenuator	CBT	N/A	N/A	1139
MiniCircuits	SLP-2400+	Low Pass Filter	CBT	N/A	N/A	R8979500903
MiniCircuits	VLF-6000+	Low Pass Filter	CBT	N/A	N/A	N/A
Mini-Circuits	BW-N20W5+	DC to 18 GHz Precision Fixed 20 dB Attenuator	CBT	N/A	N/A	N/A
Mini-Circuits	NLP-1200+	Low Pass Filter DC to 1000 MHz	CBT	N/A	N/A	N/A
Mini-Circuits	NLP-2950+	Low Pass Filter DC to 2700 MHz	CBT	N/A	N/A	N/A
Narda	4014C-6	4 - 8 GHz SMA 6 dB Directional Coupler	CBT	N/A	N/A	N/A
Narda	4772-3	Attenuator (3dB)	CBT	N/A	N/A	9406
Narda	BW-S3W2	Attenuator (3dB)	CBT	N/A	N/A	120
Rohde & Schwarz	NRVD	Dual Channel Power Meter	4/8/2011	Biennial	4/8/2013	101695
Rohde & Schwarz	SMIQ03B	Signal Generator	4/5/2012	Annual	4/5/2013	DE27259
Seekonk	NC-100	Torque Wrench (8" lb)	11/29/2011	Triennial	11/29/2014	21053
SPEAG	D2450V2	2450 MHz SAR Dipole	1/24/2012	Annual	1/24/2013	797
SPEAG	D5GHzV2	5 GHz SAR Dipole	1/19/2012	Annual	1/19/2013	1057
SPEAG	DAE4	Dasy Data Acquisition Electronics	4/19/2012	Annual	4/19/2013	665
SPEAG	DAE4	Dasy Data Acquisition Electronics	2/15/2012	Annual	2/15/2013	1323
SPEAG	DAK-3.5	Dielectric Assessment Kit	6/19/2012	Annual	6/19/2013	1070
SPEAG	EX3DV4	SAR Probe	1/27/2012	Annual	1/27/2013	3589
SPEAG	EX3DV4	SAR Probe	7/26/2012	Annual	7/26/2013	3561
Tektronix	RSA-6114A	Real Time Spectrum Analyzer	4/5/2012	Annual	4/5/2013	B010177
VWR	62344-925	Mini-Thermometer	10/24/2011	Biennial	10/24/2013	111886441
VWR	36934-158	Wall-Mounted Thermometer	1/21/2011	Biennial	1/21/2013	111286454



FCC ID: A3LEKGC100A	 PCTEST ENGINEERING LABORATORY, INC.	SAR EVALUATION REPORT		Reviewed by: Quality Manager
Document S/N: 0Y1210031460-R1.A3L	Test Dates: 8/24/12 - 8/27/12. 10/04/12 - 10/11/12	EUT Type: Portable Camera		Page 23 of 29

Applicable for 10/04/12 - 10/11/12:

Manufacturer	Model	Description	Cal Date	Cal Interval	Cal Due	Serial Number
Agilent	85070E	Dielectric Probe Kit	3/8/2012	Annual	3/8/2013	MY44300633
Agilent	8648D	Signal Generator	4/3/2012	Annual	4/3/2013	3629U00687
Agilent	85047A	S-Parameter Test Set	N/A	N/A	N/A	2904A00579
Amplifier Research	5S1G4	5W, 800MHz-4.2GHz	CBT	N/A	CBT	21910
Anritsu	ML2438A	Power Meter	2/14/2012	Annual	2/14/2013	1190013
Anritsu	ML2438A	Power Meter	2/14/2012	Annual	2/14/2013	98150041
Anritsu	MA2481A	Power Sensor	2/14/2012	Annual	2/14/2013	5318
Anritsu	MA2481A	Power Sensor	2/14/2012	Annual	2/14/2013	5442
Anritsu	MT8820C	Radio Communication Tester	11/11/2011	Annual	11/11/2012	6200901190
COMTech	AR85729-5	Solid State Amplifier	CBT	N/A	CBT	M1S5A00-009
Intelligent Weigh	PD-3000	Electronic Balance	3/27/2012	Annual	3/27/2013	11081534
MCL	BW-N6W5+	6dB Attenuator	CBT	N/A	CBT	1139
MiniCircuits	VLF-6000+	Low Pass Filter	CBT	N/A	CBT	N/A
Mini-Circuits	BW-N20W5+	DC to 18 GHz Precision Fixed 20 dB Attenuator	CBT	N/A	CBT	N/A
Mini-Circuits	NLP-1200+	Low Pass Filter DC to 1000 MHz	CBT	N/A	CBT	N/A
Mini-Circuits	NLP-2950+	Low Pass Filter DC to 2700 MHz	CBT	N/A	CBT	N/A
Mini-Circuits	BW-N20W5	Power Attenuator	CBT	N/A	CBT	1226
Narda	4014C-6	4 - 8 GHz SMA 6 dB Directional Coupler	CBT	N/A	CBT	N/A
Narda	4772-3	Attenuator (3dB)	CBT	N/A	CBT	9406
Narda	BW-S3W2	Attenuator (3dB)	CBT	N/A	CBT	120
Rohde & Schwarz	CMU200	Base Station Simulator	5/22/2012	Annual	5/22/2013	109892
Rohde & Schwarz	NRVD	Dual Channel Power Meter	4/8/2011	Biennial	4/8/2013	101695
Rohde & Schwarz	SMIQ03B	Signal Generator	4/5/2012	Annual	4/5/2013	DE27259
Seekonk	NC-100	Torque Wrench (8" lb)	11/29/2011	Triennial	11/29/2014	21053
SPEAG	D1900V2	1900 MHz SAR Dipole	2/8/2012	Annual	2/8/2013	5d148
SPEAG	D1900V2	1900 MHz SAR Dipole	2/22/2012	Annual	2/22/2013	5d149
SPEAG	D835V2	835 MHz SAR Dipole	4/20/2012	Annual	4/20/2013	4d119
SPEAG	DAE4	Dasy Data Acquisition Electronics	5/7/2012	Annual	5/7/2013	1334
SPEAG	DAE4	Dasy Data Acquisition Electronics	8/24/2012	Annual	8/24/2013	1322
SPEAG	DAK-3.5	Dielectric Assessment Kit	6/19/2012	Annual	6/19/2013	1070
SPEAG	ES3DV3	SAR Probe	4/24/2012	Annual	4/24/2013	3213
SPEAG	ES3DV2	SAR Probe	8/28/2012	Annual	8/28/2013	3022
Tektronix	RSA-6114A	Real Time Spectrum Analyzer	4/5/2012	Annual	4/5/2013	B010177
VWR	62344-925	Mini-Thermometer	10/24/2011	Biennial	10/24/2013	111886430
VWR	36934-158	Wall-Mounted Thermometer	1/21/2011	Biennial	1/21/2013	111286445

Note:

1. CBT (Calibrated Before Testing). Prior to testing, the measurement paths containing a cable, attenuator, coupler, amplifier or filter were connected to a calibrated source (i.e. a signal generator) to determine the losses of the measurement path. The power meter offset was then adjusted to compensate for the measurement system losses. This level offset is stored within the power meter before measurements are made. This calibration verification procedure applies to the system verification and output power measurements. The calibrated reading is then taken directly from the power meter after compensation of the losses for all final power measurements.
2. Agilent 85047A S-Parameter Test Set is used as a connector dock in series with a calibrated network analyzer. All measurements are made by the calibrated network analyzer; therefore no calibration is needed for this Test Set.



FCC ID: A3LEKGC100A	 PCTEST ENGINEERING LABORATORY, INC.	SAR EVALUATION REPORT		Reviewed by: Quality Manager
Document S/N: 0Y1210031460-R1.A3L	Test Dates: 8/24/12 - 8/27/12. 10/04/12 - 10/11/12	EUT Type: Portable Camera		Page 24 of 29

13 MEASUREMENT UNCERTAINTIES

Applicable for frequencies less than 3000 MHz:

a	b	c	d	e= f(d,k)	f	g	h = c x f/e	i = c x g/e	k
Uncertainty Component	IEEE 1528 Sec.	Tol. (± %)	Prob. Dist.	Div.	c _i 1gm	c _i 10 gms	1gm u _i (± %)	10gms u _i (± %)	v _i
Measurement System									
Probe Calibration	E.2.1	6.0	N	1	1.0	1.0	6.0	6.0	∞
Axial Isotropy	E.2.2	0.25	N	1	0.7	0.7	0.2	0.2	∞
Hemishperical Isotropy	E.2.2	1.3	N	1	1.0	1.0	1.3	1.3	∞
Boundary Effect	E.2.3	0.4	N	1	1.0	1.0	0.4	0.4	∞
Linearity	E.2.4	0.3	N	1	1.0	1.0	0.3	0.3	∞
System Detection Limits	E.2.5	5.1	N	1	1.0	1.0	5.1	5.1	∞
Readout Electronics	E.2.6	1.0	N	1	1.0	1.0	1.0	1.0	∞
Response Time	E.2.7	0.8	R	1.73	1.0	1.0	0.5	0.5	∞
Integration Time	E.2.8	2.6	R	1.73	1.0	1.0	1.5	1.5	∞
RF Ambient Conditions	E.6.1	3.0	R	1.73	1.0	1.0	1.7	1.7	∞
Probe Positioner Mechanical Tolerance	E.6.2	0.4	R	1.73	1.0	1.0	0.2	0.2	∞
Probe Positioning w/ respect to Phantom	E.6.3	2.9	R	1.73	1.0	1.0	1.7	1.7	∞
Extrapolation, Interpolation & Integration algorithms for Max. SAR Evaluation	E.5	1.0	R	1.73	1.0	1.0	0.6	0.6	∞
Test Sample Related									
Test Sample Positioning	E.4.2	6.0	N	1	1.0	1.0	6.0	6.0	287
Device Holder Uncertainty	E.4.1	3.32	R	1.73	1.0	1.0	1.9	1.9	∞
Output Power Variation - SAR drift measurement	6.6.2	5.0	R	1.73	1.0	1.0	2.9	2.9	∞
Phantom & Tissue Parameters									
Phantom Uncertainty (Shape & Thickness tolerances)	E.3.1	4.0	R	1.73	1.0	1.0	2.3	2.3	∞
Liquid Conductivity - deviation from target values	E.3.2	5.0	R	1.73	0.64	0.43	1.8	1.2	∞
Liquid Conductivity - measurement uncertainty	E.3.3	3.8	N	1	0.64	0.43	2.4	1.6	6
Liquid Permittivity - deviation from target values	E.3.2	5.0	R	1.73	0.60	0.49	1.7	1.4	∞
Liquid Permittivity - measurement uncertainty	E.3.3	4.5	N	1	0.60	0.49	2.7	2.2	6
Combined Standard Uncertainty (k=1)				RSS			12.1	11.7	299
Expanded Uncertainty (95% CONFIDENCE LEVEL)				k=2			24.2	23.5	



The above measurement uncertainties are according to IEEE Std. 1528-2003

FCC ID: A3LEKGC100A	 PCTEST ENGINEERING LABORATORY, INC.	SAR EVALUATION REPORT		Reviewed by: Quality Manager
Document S/N: 0Y1210031460-R1.A3L	Test Dates: 8/24/12 - 8/27/12. 10/04/12 - 10/11/12	EUT Type: Portable Camera		Page 25 of 29

Applicable for frequencies up to 6 GHz:

a	b	c	d	e= f(d,k)	f	g	h = c x f/e	i = c x g/e	k	
Uncertainty Component	IEEE 1528 Sec.	Tol. (± %)	Prob. Dist.	Div.	c _i 1gm	c _i 10 gms	1gm u _i (± %)	10gms u _i (± %)	v _i	
Measurement System										
Probe Calibration	E.2.1	6.55	N	1	1.0	1.0	6.6	6.6	∞	
Axial Isotropy	E.2.2	0.25	N	1	0.7	0.7	0.2	0.2	∞	
Hemishperical Isotropy	E.2.2	1.3	N	1	1.0	1.0	1.3	1.3	∞	
Boundary Effect	E.2.3	0.4	N	1	1.0	1.0	0.4	0.4	∞	
Linearity	E.2.4	0.3	N	1	1.0	1.0	0.3	0.3	∞	
System Detection Limits	E.2.5	5.1	N	1	1.0	1.0	5.1	5.1	∞	
Readout Electronics	E.2.6	1.0	N	1	1.0	1.0	1.0	1.0	∞	
Response Time	E.2.7	0.8	R	1.73	1.0	1.0	0.5	0.5	∞	
Integration Time	E.2.8	2.6	R	1.73	1.0	1.0	1.5	1.5	∞	
RF Ambient Conditions	E.6.1	3.0	R	1.73	1.0	1.0	1.7	1.7	∞	
Probe Positioner Mechanical Tolerance	E.6.2	0.4	R	1.73	1.0	1.0	0.2	0.2	∞	
Probe Positioning w/ respect to Phantom	E.6.3	2.9	R	1.73	1.0	1.0	1.7	1.7	∞	
Extrapolation, Interpolation & Integration algorithms for Max. SAR Evaluation	E.5	1.0	R	1.73	1.0	1.0	0.6	0.6	∞	
Test Sample Related										
Test Sample Positioning	E.4.2	6.0	N	1	1.0	1.0	6.0	6.0	287	
Device Holder Uncertainty	E.4.1	3.32	R	1.73	1.0	1.0	1.9	1.9	∞	
Output Power Variation - SAR drift measurement	6.6.2	5.0	R	1.73	1.0	1.0	2.9	2.9	∞	
Phantom & Tissue Parameters										
Phantom Uncertainty (Shape & Thickness tolerances)	E.3.1	4.0	R	1.73	1.0	1.0	2.3	2.3	∞	
Liquid Conductivity - deviation from target values	E.3.2	5.0	R	1.73	0.64	0.43	1.8	1.2	∞	
Liquid Conductivity - measurement uncertainty	E.3.3	3.8	N	1	0.64	0.43	2.4	1.6	6	
Liquid Permittivity - deviation from target values	E.3.2	5.0	R	1.73	0.60	0.49	1.7	1.4	∞	
Liquid Permittivity - measurement uncertainty	E.3.3	4.5	N	1	0.60	0.49	2.7	2.2	6	
Combined Standard Uncertainty (k=1)							RSS	12.4	12.0	299
Expanded Uncertainty (95% CONFIDENCE LEVEL)							k=2	24.7	24.0	

The above measurement uncertainties are according to IEEE Std. 1528-2003



FCC ID: A3LEKGC100A	 PCTEST ENGINEERING LABORATORY, INC.	SAR EVALUATION REPORT		Reviewed by: Quality Manager
Document S/N: 0Y1210031460-R1.A3L	Test Dates: 8/24/12 - 8/27/12. 10/04/12 - 10/11/12	EUT Type: Portable Camera		Page 26 of 29

14 CONCLUSION

14.1 Measurement Conclusion



The SAR evaluation indicates that the EUT complies with the RF radiation exposure limits of the FCC and Industry Canada, with respect to all parameters subject to this test. These measurements were taken to simulate the RF effects of RF exposure under worst-case conditions. Precise laboratory measures were taken to assure repeatability of the tests. The results and statements relate only to the item(s) tested.

Please note that the absorption and distribution of electromagnetic energy in the body are very complex phenomena that depend on the mass, shape, and size of the body, the orientation of the body with respect to the field vectors, and the electrical properties of both the body and the environment. Other variables that may play a substantial role in possible biological effects are those that characterize the environment (e.g. ambient temperature, air velocity, relative humidity, and body insulation) and those that characterize the individual (e.g. age, gender, activity level, debilitation, or disease). Because various factors may interact with one another to vary the specific biological outcome of an exposure to electromagnetic fields, any protection guide should consider maximal amplification of biological effects as a result of field-body interactions, environmental conditions, and physiological variables. [3]



FCC ID: A3LEKGC100A		SAR EVALUATION REPORT		Reviewed by: Quality Manager
Document S/N: 0Y1210031460-R1.A3L	Test Dates: 8/24/12 - 8/27/12. 10/04/12 - 10/11/12	EUT Type: Portable Camera		Page 27 of 29

15 REFERENCES

- [1] Federal Communications Commission, ET Docket 93-62, Guidelines for Evaluating the Environmental Effects of Radiofrequency Radiation, Aug. 1996.
- [2] ANSI/IEEE C95.1-2005, American National Standard safety levels with respect to human exposure to radio frequency electromagnetic fields, 3kHz to 300GHz, New York: IEEE, 2006.
- [3] ANSI/IEEE C95.1-1992, American National Standard safety levels with respect to human exposure to radio frequency electromagnetic fields, 3kHz to 300GHz, New York: IEEE, Sept. 1992.
- [4] ANSI/IEEE C95.3-2002, IEEE Recommended Practice for the Measurement of Potentially Hazardous Electromagnetic Fields - RF and Microwave, New York: IEEE, December 2002.
- [5] Federal Communications Commission, OET Bulletin 65 (Edition 97-01), Supplement C (Edition 01-01), Evaluating Compliance with FCC Guidelines for Human Exposure to Radiofrequency Electromagnetic Fields, June 2001.
- [6] IEEE Standards Coordinating Committee 34 – IEEE Std. 1528-2003, Recommended Practice for Determining the Peak Spatial-Average Specific Absorption Rate (SAR) in the Human Body Due to Wireless Communications Devices.
- [7] NCRP, National Council on Radiation Protection and Measurements, Biological Effects and Exposure Criteria for RadioFrequency Electromagnetic Fields, NCRP Report No. 86, 1986. Reprinted Feb. 1995.
- [8] T. Schmid, O. Egger, N. Kuster, Automated E-field scanning system for dosimetric assessments, IEEE Transaction on Microwave Theory and Techniques, vol. 44, Jan. 1996, pp. 105-113.
- [9] K. Pokovic, T. Schmid, N. Kuster, Robust setup for precise calibration of E-field probes in tissue simulating liquids at mobile communications frequencies, ICECOM97, Oct. 1997, pp. 120-124.
- [10] K. Pokovic, T. Schmid, and N. Kuster, E-field Probe with improved isotropy in brain simulating liquids, Proceedings of the ELMAR, Zadar, Croatia, June 23-25, 1996, pp. 172-175.
- [11] Schmid & Partner Engineering AG, Application Note: Data Storage and Evaluation, June 1998, p2.
- [12] V. Hombach, K. Meier, M. Burkhardt, E. Kuhn, N. Kuster, The Dependence of EM Energy Absorption upon Human Head Modeling at 900 MHz, IEEE Transaction on Microwave Theory and Techniques, vol. 44 no. 10, Oct. 1996, pp. 1865-1873.
- [13] N. Kuster and Q. Balzano, Energy absorption mechanism by biological bodies in the near field of dipole antennas above 300MHz, IEEE Transaction on Vehicular Technology, vol. 41, no. 1, Feb. 1992, pp. 17-23.
- [14] G. Hartsgrrove, A. Kraszewski, A. Surowiec, Simulated Biological Materials for Electromagnetic Radiation Absorption Studies, University of Ottawa, Bioelectromagnetics, Canada: 1987, pp. 29-36.
- [15] Q. Balzano, O. Garay, T. Manning Jr., Electromagnetic Energy Exposure of Simulated Users of Portable Cellular Telephones, IEEE Transactions on Vehicular Technology, vol. 44, no.3, Aug. 1995.
- [16] W. Gander, Computermathematik, Birkhaeuser, Basel, 1992.
- [17] W.H. Press, S.A. Teukolsky, W.T. Vetterling, and B.P. Flannery, Numerical Recipes in C, The Art of Scientific Computing, Second edition, Cambridge University Press, 1992.

FCC ID: A3LEKGC100A	 PCTEST ENGINEERING LABORATORY, INC.	SAR EVALUATION REPORT		Reviewed by: Quality Manager
Document S/N: 0Y1210031460-R1.A3L	Test Dates: 8/24/12 - 8/27/12. 10/04/12 - 10/11/12	EUT Type: Portable Camera		Page 28 of 29

- [18] Federal Communications Commission, OET Bulletin 65, Evaluating Compliance with FCC Guidelines for Human Exposure to Radiofrequency Electromagnetic Fields. Supplement C, Dec. 1997.
- [19] N. Kuster, R. Kastle, T. Schmid, Dosimetric evaluation of mobile communications equipment with known precision, IEEE Transaction on Communications, vol. E80-B, no. 5, May 1997, pp. 645-652.
- [20] CENELEC CLC/SC111B, European Prestandard (prENV 50166-2), Human Exposure to Electromagnetic Fields High-frequency: 10kHz-300GHz, Jan. 1995.
- [21] Prof. Dr. Niels Kuster, ETH, Eidgenössische Technische Hochschule Zürich, Dosimetric Evaluation of the Cellular Phone.
- [22] IEC 62209-1, Human exposure to radio frequency fields from hand-held and body-mounted wireless communication devices - Human models, instrumentation, and procedures - Part 1: Procedure to determine the specific absorption rate (SAR) for hand-held devices used in close proximity to the ear (frequency range of 300 MHz to 3 GHz), Feb. 2005.
- [23] Industry Canada RSS-102 Radio Frequency Exposure Compliance of Radiocommunication Apparatus (All Frequency Bands) Issue 4, March 2010.
- [24] Health Canada Safety Code 6 Limits of Human Exposure to Radio Frequency Electromagnetic Fields in the Frequency Range from 3 kHz – 300 GHz, 2009
- [25] FCC Public Notice DA-02-1438. Office of Engineering and Technology Announces a Transition Period for the Phantom Requirements of Supplement C to OET Bulletin 65, June 19, 2002
- [26] FCC SAR Measurement Procedures for 3G Devices KDB Publication 941225
- [27] SAR Measurement procedures for IEEE 802.11a/b/g KDB Publication 248227
- [28] FCC SAR Considerations for Handsets with Multiple Transmitters and Antennas, KDB Publication 648474
- [29] FCC Application Note for SAR Probe Calibration and System Verification Consideration for Measurements at 150 MHz – 3 GHz, KDB Publication 450824
- [30] FCC SAR Evaluation Considerations for Laptop Computers with Antennas Built-in on Display Screens, KDB Publication 616217
- [31] FCC SAR Measurement Requirements for 3 – 6 GHz, KDB Publication 865664
- [32] FCC Mobile Portable RF Exposure Procedure, KDB Publication 447498
- [33] FCC SAR Procedures for Dongle Transmitters, KDB Publication 447498
- [34] Anexo à Resolução No. 533, de 10 de Setembro de 2009.
- [35] FCC SAR Test Considerations for LTE Handsets and Data Modems, KDB Publication 941225.
- [36] IEC 62209-2, Human exposure to radio frequency fields from hand-held and body-mounted wireless communication devices - Human models, instrumentation, and procedures - Part 2: Procedure to determine the specific absorption rate (SAR) for wireless communication devices used in close proximity to the human body (frequency range of 30 MHz to 6 GHz), Mar. 2010.
- [37] FCC Hot Spot SAR v01, KDB Publication 941225 D06.

FCC ID: A3LEKGC100A		SAR EVALUATION REPORT		Reviewed by: Quality Manager
Document S/N: 0Y1210031460-R1.A3L	Test Dates: 8/24/12 - 8/27/12. 10/04/12 - 10/11/12	EUT Type: Portable Camera		Page 29 of 29

APPENDIX A: SAR TEST DATA

PCTEST ENGINEERING LABORATORY, INC.

EUT: A3LEKGC100A; Type: Portable Camera; Serial: S3GC-0001

Communication System: WCDMA850; Frequency: 836.6 MHz; Duty Cycle: 1:1

Medium: 835 Body Medium parameters used (interpolated):

$f = 836.6 \text{ MHz}$; $\sigma = 0.978 \text{ mho/m}$; $\epsilon_r = 54.034$; $\rho = 1000 \text{ kg/m}^3$

Phantom section: Flat Section; Space: 0.0 cm

Test Date: 10-05-2012; Ambient Temp: 23.8°C; Tissue Temp: 22.8°C

Probe: ES3DV2 - SN3022; ConvF(6.02, 6.02, 6.02); Calibrated: 8/28/2012;

Sensor-Surface: 4mm (Mechanical Surface Detection)

Electronics: DAE4 Sn1322; Calibrated: 8/24/2012

Phantom: SAM Main; Type: SAM 4.0; Serial: TP-1406

Measurement SW: DASY4, Version 4.7 (80);SEMCAD X Version 14.6.5 (6469)

Mode: WCDMA 850, Hand SAR, Back Side, Mid.ch

Area Scan (7x11x1): Measurement grid: dx=15mm, dy=15mm

Zoom Scan (5x5x7)/Cube 0: Measurement grid: dx=8mm, dy=8mm, dz=5mm

Reference Value = 19.192 V/m; Power Drift = -0.03 dB

Peak SAR (extrapolated) = 0.571 mW/g

SAR(1 g) = 0.331 mW/g; SAR(10 g) = 0.194 mW/g

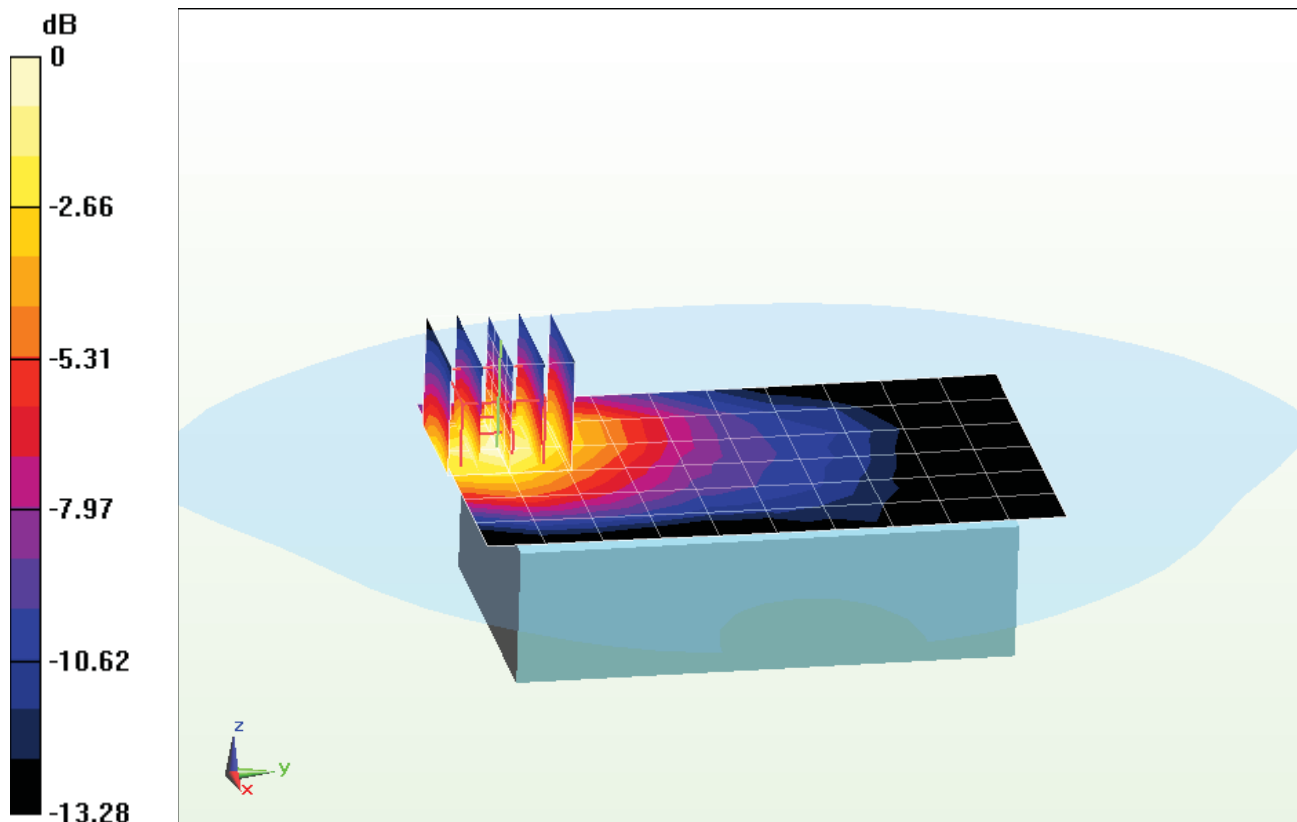

0 dB = 0.360 mW/g = -8.87 dB mW/g

PCTEST ENGINEERING LABORATORY, INC.

EUT: A3LEKGC100A; Type: Portable Camera; Serial: S3GC-0001

Communication System: WCDMA850; Frequency: 836.6 MHz; Duty Cycle: 1:1

Medium: 835 Body Medium parameters used (interpolated):

$f = 836.6 \text{ MHz}$; $\sigma = 0.978 \text{ mho/m}$; $\epsilon_r = 54.034$; $\rho = 1000 \text{ kg/m}^3$

Phantom section: Flat Section; Space: 0.0 cm

Test Date: 10-05-2012; Ambient Temp: 23.8°C; Tissue Temp: 22.8°C

Probe: ES3DV2 - SN3022; ConvF(6.02, 6.02, 6.02); Calibrated: 8/28/2012;

Sensor-Surface: 4mm (Mechanical Surface Detection)

Electronics: DAE4 Sn1322; Calibrated: 8/24/2012

Phantom: SAM Main; Type: SAM 4.0; Serial: TP-1406

Measurement SW: DASY4, Version 4.7 (80);SEMCAD X Version 14.6.5 (6469)

Mode: WCDMA 850, Hand SAR, Front Side, Mid.ch

Area Scan (7x12x1): Measurement grid: dx=15mm, dy=15mm

Zoom Scan (5x5x7)/Cube 0: Measurement grid: dx=8mm, dy=8mm, dz=5mm

Reference Value = 25.603 V/m; Power Drift = -0.05 dB

Peak SAR (extrapolated) = 2.593 mW/g

SAR(1 g) = 0.851 mW/g; SAR(10 g) = 0.420 mW/g

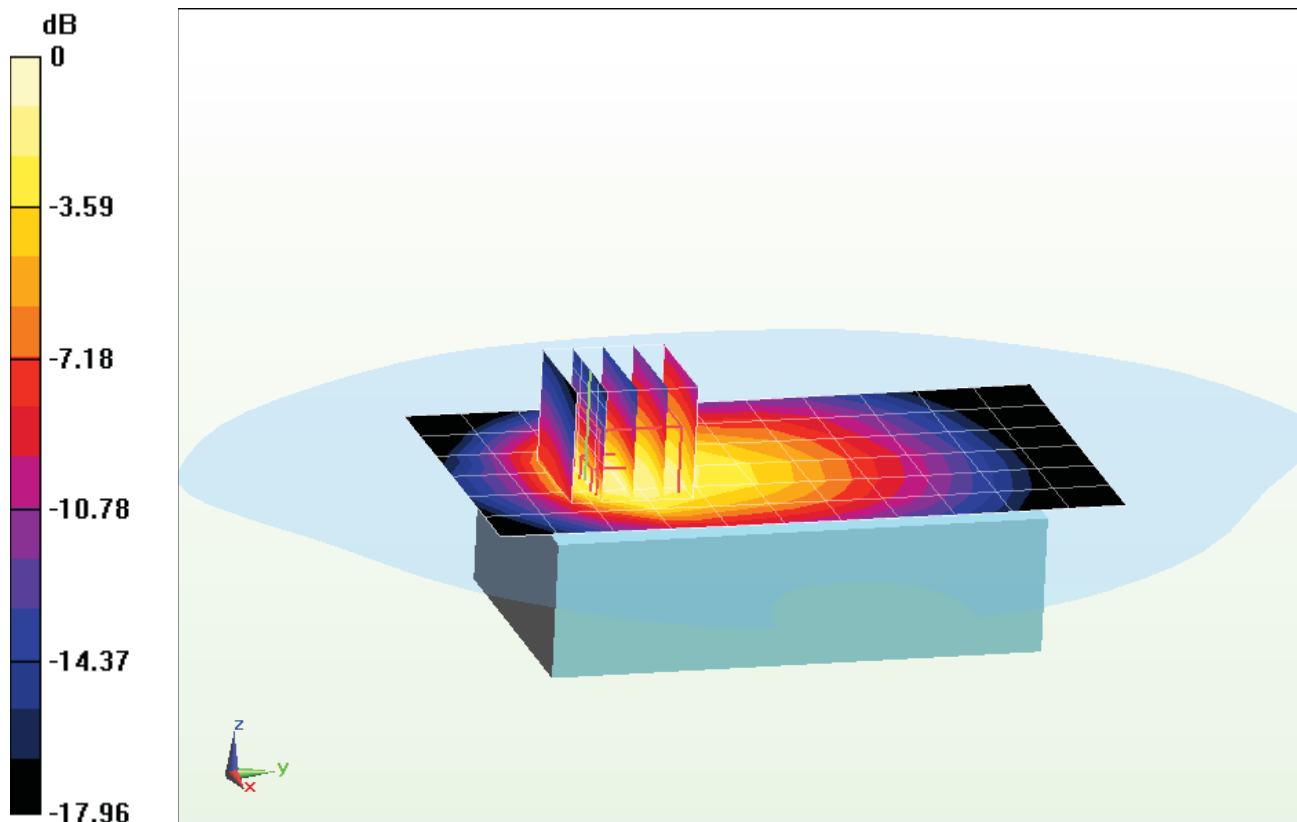

0 dB = 0.829 mW/g = -1.63 dB mW/g

PCTEST ENGINEERING LABORATORY, INC.

EUT: A3LEKGC100A; Type: Portable Camera; Serial: S3GC-0001

Communication System: WCDMA850; Frequency: 836.6 MHz; Duty Cycle: 1:1

Medium: 835 Body Medium parameters used (interpolated):

$f = 836.6 \text{ MHz}$; $\sigma = 0.978 \text{ mho/m}$; $\epsilon_r = 54.034$; $\rho = 1000 \text{ kg/m}^3$

Phantom section: Flat Section; Space: 0.0 cm

Test Date: 10-05-2012; Ambient Temp: 23.8°C; Tissue Temp: 22.8°C

Probe: ES3DV2 - SN3022; ConvF(6.02, 6.02, 6.02); Calibrated: 8/28/2012;

Sensor-Surface: 4mm (Mechanical Surface Detection)

Electronics: DAE4 Sn1322; Calibrated: 8/24/2012

Phantom: SAM Main; Type: SAM 4.0; Serial: TP-1406

Measurement SW: DASY4, Version 4.7 (80);SEMCAD X Version 14.6.5 (6469)

Mode: WCDMA 850, Hand SAR, Bottom Edge, Mid.ch

Area Scan (16x11x1): Measurement grid: dx=5mm, dy=15mm

Zoom Scan (5x5x7)/Cube 0: Measurement grid: dx=8mm, dy=8mm, dz=5mm

Reference Value = 19.245 V/m; Power Drift = -0.02 dB

Peak SAR (extrapolated) = 0.553 mW/g

SAR(1 g) = 0.330 mW/g; SAR(10 g) = 0.209 mW/g

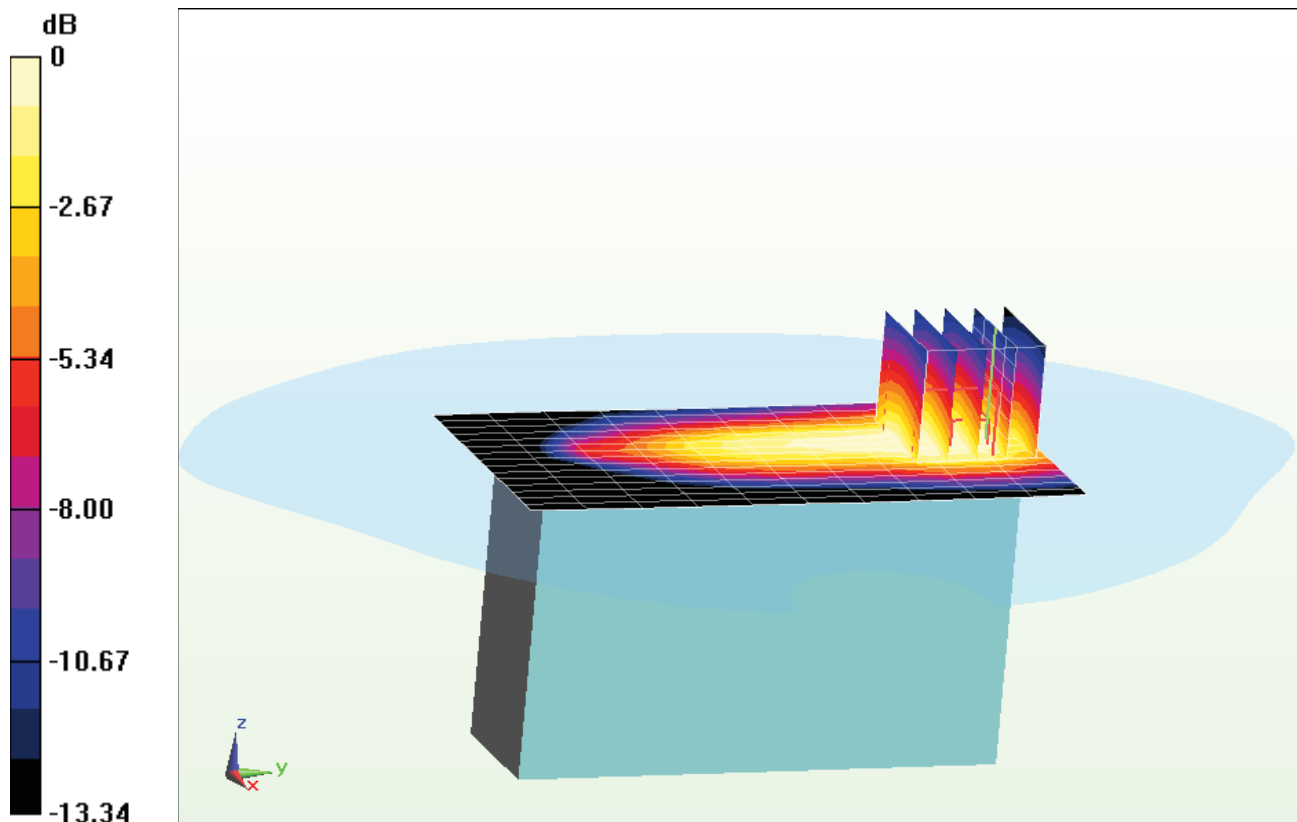

0 dB = 0.341 mW/g = -9.34 dB mW/g

PCTEST ENGINEERING LABORATORY, INC.

EUT: A3LEKGC100A; Type: Portable Camera; Serial: S3GC-0001

Communication System: WCDMA850; Frequency: 836.6 MHz; Duty Cycle: 1:1

Medium: 835 Body Medium parameters used (interpolated):

$f = 836.6 \text{ MHz}$; $\sigma = 0.978 \text{ mho/m}$; $\epsilon_r = 54.034$; $\rho = 1000 \text{ kg/m}^3$

Phantom section: Flat Section; Space: 0.0 cm

Test Date: 10-05-2012; Ambient Temp: 23.8°C; Tissue Temp: 22.8°C

Probe: ES3DV2 - SN3022; ConvF(6.02, 6.02, 6.02); Calibrated: 8/28/2012;

Sensor-Surface: 4mm (Mechanical Surface Detection)

Electronics: DAE4 Sn1322; Calibrated: 8/24/2012

Phantom: SAM Main; Type: SAM 4.0; Serial: TP-1406

Measurement SW: DASY4, Version 4.7 (80);SEMCAD X Version 14.6.5 (6469)

Mode: WCDMA 850, Hand SAR, Left Edge, Mid.ch

Area Scan (13x8x1): Measurement grid: dx=5mm, dy=15mm

Zoom Scan (5x5x7)/Cube 0: Measurement grid: dx=8mm, dy=8mm, dz=5mm

Reference Value = 46.301 V/m; Power Drift = -0.01 dB

Peak SAR (extrapolated) = 4.574 mW/g

SAR(1 g) = 1.83 mW/g; SAR(10 g) = 0.790 mW/g

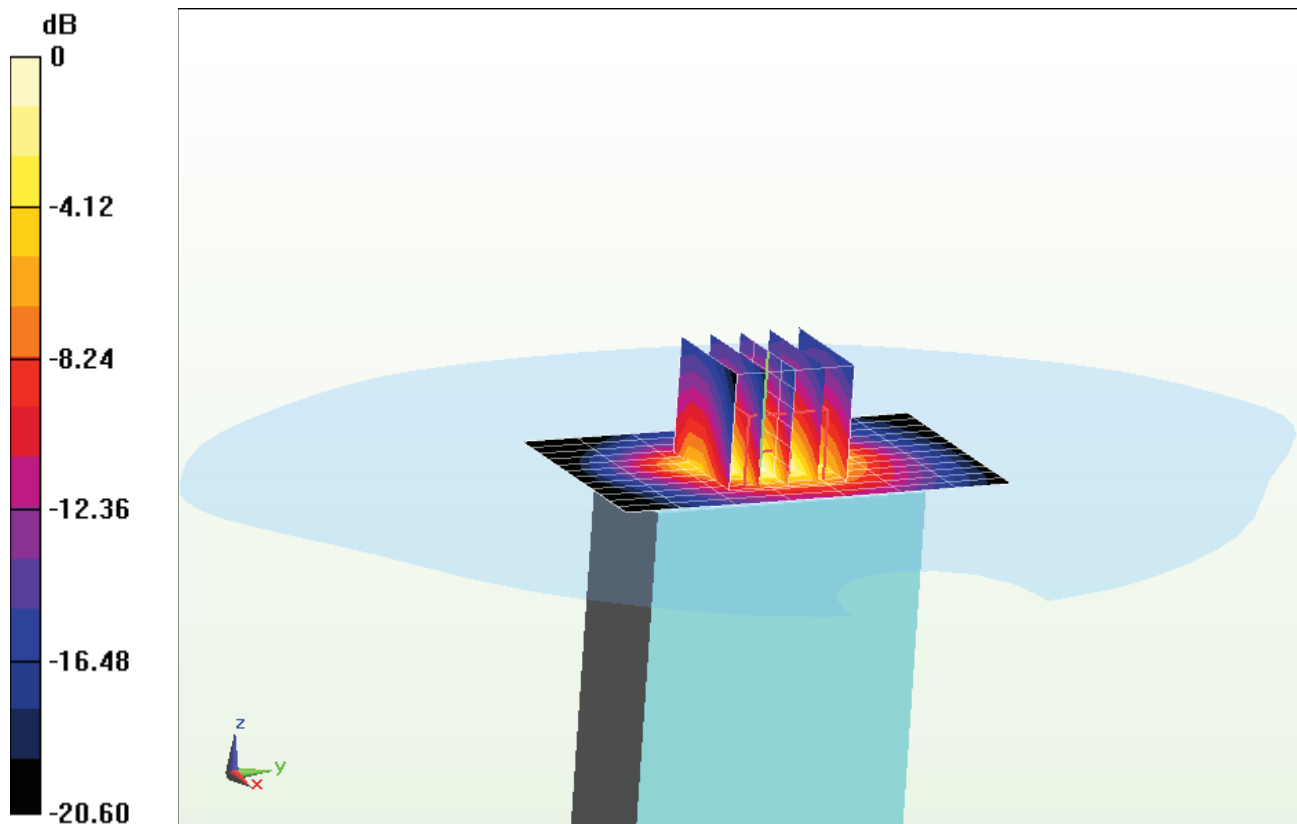

0 dB = 2.28 mW/g = 7.16 dB mW/g

PCTEST ENGINEERING LABORATORY, INC.

EUT: A3LEKGC100A; Type: Portable Camera; Serial: S3GC-0001

Communication System: WCDMA850; Frequency: 836.6 MHz; Duty Cycle: 1:1

Medium: 835 Body Medium parameters used (interpolated):

$f = 836.6 \text{ MHz}$; $\sigma = 0.978 \text{ mho/m}$; $\epsilon_r = 54.034$; $\rho = 1000 \text{ kg/m}^3$

Phantom section: Flat Section; Space: 1.0 cm

Test Date: 10-05-2012; Ambient Temp: 23.8°C; Tissue Temp: 22.8°C

Probe: ES3DV2 - SN3022; ConvF(6.02, 6.02, 6.02); Calibrated: 8/28/2012;

Sensor-Surface: 4mm (Mechanical Surface Detection)

Electronics: DAE4 Sn1322; Calibrated: 8/24/2012

Phantom: SAM Main; Type: SAM 4.0; Serial: TP-1406

Measurement SW: DASY4, Version 4.7 (80);SEMCAD X Version 14.6.5 (6469)

Mode: WCDMA 850, Body SAR, Back Side, Mid.ch

Area Scan (7x12x1): Measurement grid: dx=15mm, dy=15mm

Zoom Scan (5x5x7)/Cube 0: Measurement grid: dx=8mm, dy=8mm, dz=5mm

Reference Value = 13.996 V/m; Power Drift = 0.02 dB

Peak SAR (extrapolated) = 0.220 mW/g

SAR(1 g) = 0.180 mW/g; SAR(10 g) = 0.140 mW/g

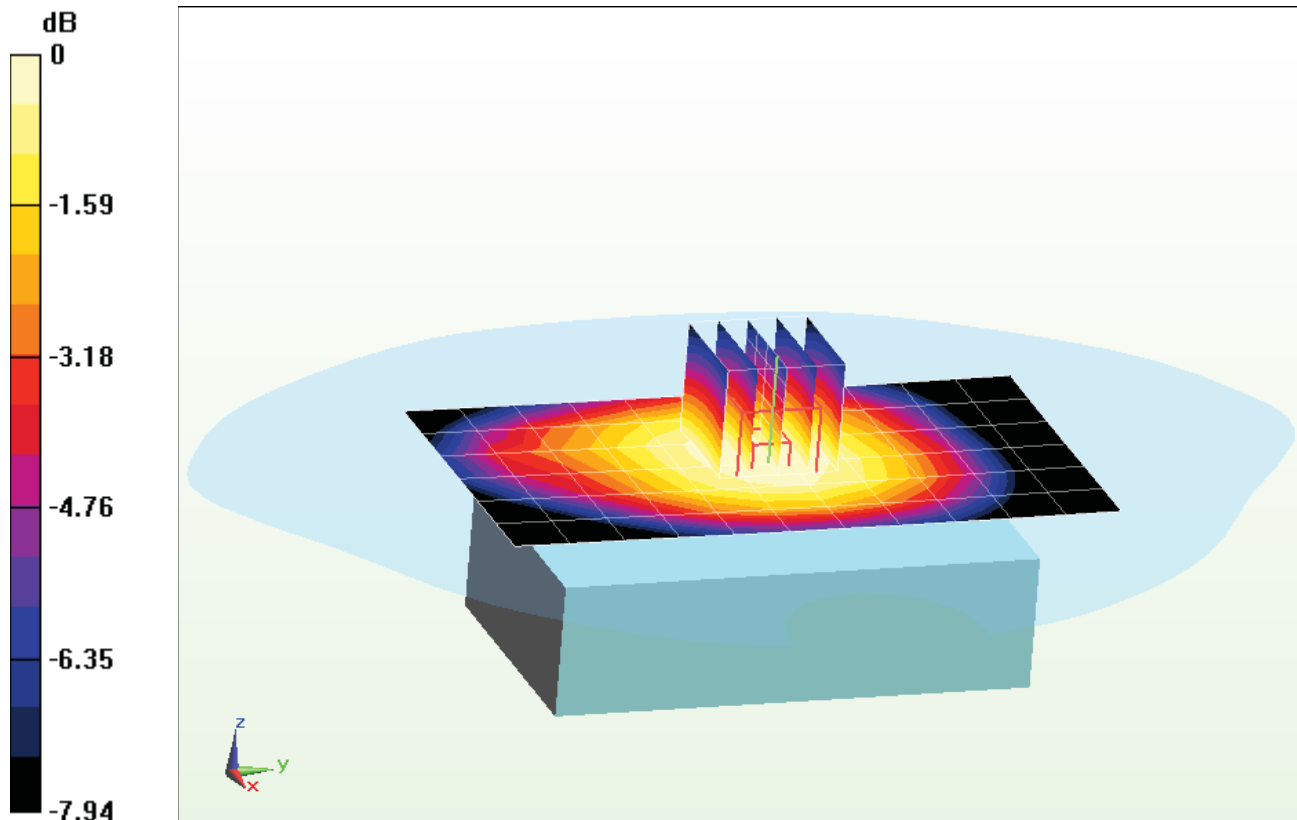

0 dB = 0.188 mW/g = -14.52 dB mW/g

PCTEST ENGINEERING LABORATORY, INC.

EUT: A3LEKGC100A; Type: Portable Camera; Serial: S3GC-0001

Communication System: WCDMA850; Frequency: 836.6 MHz; Duty Cycle: 1:1

Medium: 835 Body Medium parameters used (interpolated):

$f = 836.6 \text{ MHz}$; $\sigma = 0.978 \text{ mho/m}$; $\epsilon_r = 54.034$; $\rho = 1000 \text{ kg/m}^3$

Phantom section: Flat Section; Space: 1.0 cm

Test Date: 10-05-2012; Ambient Temp: 23.8°C; Tissue Temp: 22.8°C

Probe: ES3DV2 - SN3022; ConvF(6.02, 6.02, 6.02); Calibrated: 8/28/2012;

Sensor-Surface: 4mm (Mechanical Surface Detection)

Electronics: DAE4 Sn1322; Calibrated: 8/24/2012

Phantom: SAM Main; Type: SAM 4.0; Serial: TP-1406

Measurement SW: DASY4, Version 4.7 (80);SEMCAD X Version 14.6.5 (6469)

Mode: WCDMA 850, Body SAR, Front Side, Mid.ch

Area Scan (7x12x1): Measurement grid: dx=15mm, dy=15mm

Zoom Scan (5x5x7)/Cube 0: Measurement grid: dx=8mm, dy=8mm, dz=5mm

Reference Value = 19.845 V/m; Power Drift = 0.00 dB

Peak SAR (extrapolated) = 0.456 mW/g

SAR(1 g) = 0.362 mW/g; SAR(10 g) = 0.273 mW/g

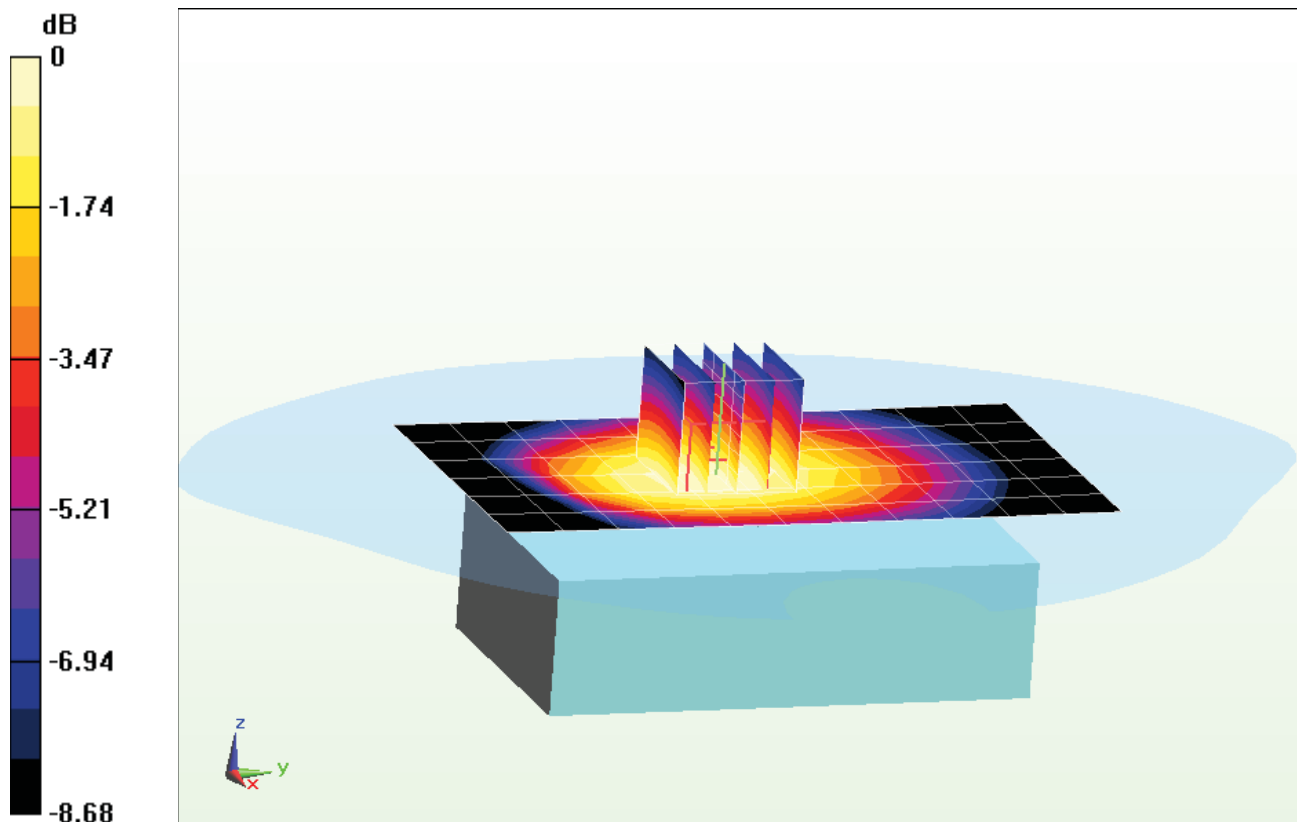

0 dB = 0.380 mW/g = -8.40 dB mW/g

PCTEST ENGINEERING LABORATORY, INC.

EUT: A3LEKGC100A; Type: Portable Camera; Serial: S3GC-0001

Communication System: WCDMA850; Frequency: 836.6 MHz; Duty Cycle: 1:1

Medium: 835 Body Medium parameters used (interpolated):

$f = 836.6 \text{ MHz}$; $\sigma = 0.978 \text{ mho/m}$; $\epsilon_r = 54.034$; $\rho = 1000 \text{ kg/m}^3$

Phantom section: Flat Section; Space: 1.0 cm

Test Date: 10-05-2012; Ambient Temp: 23.8°C; Tissue Temp: 22.8°C

Probe: ES3DV2 - SN3022; ConvF(6.02, 6.02, 6.02); Calibrated: 8/28/2012;

Sensor-Surface: 4mm (Mechanical Surface Detection)

Electronics: DAE4 Sn1322; Calibrated: 8/24/2012

Phantom: SAM Main; Type: SAM 4.0; Serial: TP-1406

Measurement SW: DASY4, Version 4.7 (80);SEMCAD X Version 14.6.5 (6469)

Mode: WCDMA 850, Body SAR, Bottom Edge, Mid.ch

Area Scan (16x11x1): Measurement grid: dx=5mm, dy=15mm

Zoom Scan (5x5x7)/Cube 0: Measurement grid: dx=8mm, dy=8mm, dz=5mm

Reference Value = 19.646 V/m; Power Drift = -0.04 dB

Peak SAR (extrapolated) = 0.483 mW/g

SAR(1 g) = 0.355 mW/g; SAR(10 g) = 0.248 mW/g

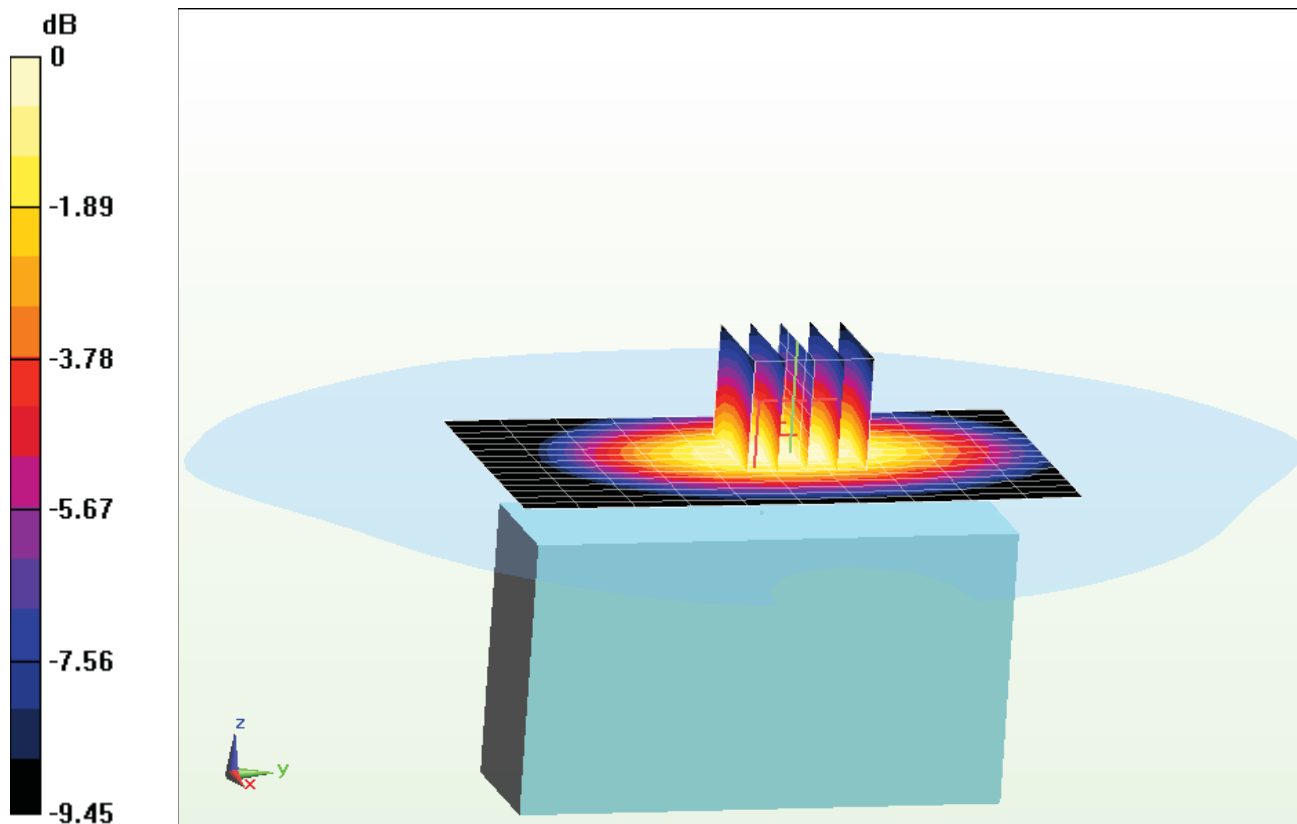

0 dB = 0.379 mW/g = -8.43 dB mW/g

PCTEST ENGINEERING LABORATORY, INC.

EUT: A3LEKGC100A; Type: Portable Camera; Serial: S3GC-0001

Communication System: WCDMA850; Frequency: 836.6 MHz; Duty Cycle: 1:1

Medium: 835 Body Medium parameters used (interpolated):

$f = 836.6 \text{ MHz}$; $\sigma = 0.978 \text{ mho/m}$; $\epsilon_r = 54.034$; $\rho = 1000 \text{ kg/m}^3$

Phantom section: Flat Section; Space: 1.0 cm

Test Date: 10-05-2012; Ambient Temp: 23.8°C; Tissue Temp: 22.8°C

Probe: ES3DV2 - SN3022; ConvF(6.02, 6.02, 6.02); Calibrated: 8/28/2012;

Sensor-Surface: 4mm (Mechanical Surface Detection)

Electronics: DAE4 Sn1322; Calibrated: 8/24/2012

Phantom: SAM Main; Type: SAM 4.0; Serial: TP-1406

Measurement SW: DASY4, Version 4.7 (80);SEMCAD X Version 14.6.5 (6469)

Mode: WCDMA 850, Body SAR, Left Edge, Mid.ch

Area Scan (13x8x1): Measurement grid: dx=5mm, dy=15mm

Zoom Scan (5x5x7)/Cube 0: Measurement grid: dx=8mm, dy=8mm, dz=5mm

Reference Value = 14.485 V/m; Power Drift = -0.02 dB

Peak SAR (extrapolated) = 0.323 mW/g

SAR(1 g) = 0.197 mW/g; SAR(10 g) = 0.115 mW/g

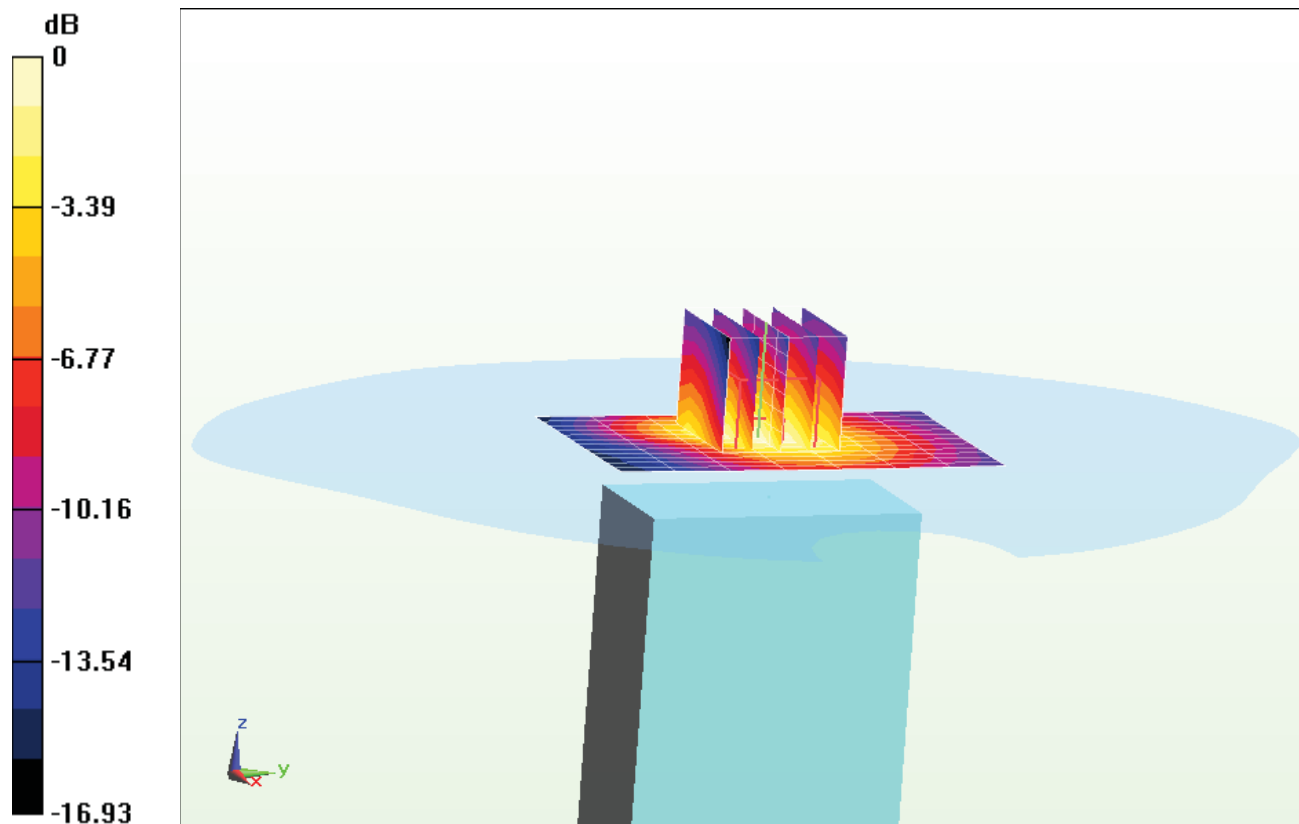

0 dB = 0.220 mW/g = -13.15 dB mW/g

PCTEST ENGINEERING LABORATORY, INC.

EUT: A3LEKGC100A; Type: Portable Camera; Serial: S3GC-0002

Communication System: WCDMA; Frequency: 1880 MHz; Duty Cycle: 1:1

Medium: 1900 Body Medium parameters used:

$f = 1880 \text{ MHz}$; $\sigma = 1.54 \text{ mho/m}$; $\epsilon_r = 52.02$; $\rho = 1000 \text{ kg/m}^3$

Phantom section: Flat Section; Space: 0.0 cm

Test Date: 10-04-2012; Ambient Temp: 24.1°C; Tissue Temp: 23.0°C

Probe: ES3DV3 - SN3213; ConvF(4.5, 4.5, 4.5); Calibrated: 4/24/2012;

Sensor-Surface: 4mm (Mechanical Surface Detection)

Electronics: DAE4 Sn1334; Calibrated: 5/7/2012

Phantom: ELI v5.0 Door; Type: QDOVA002BB; Serial: TP-1158

Measurement SW: DASY52, Version 52.8 (1);SEMCAD X Version 14.6.5 (6469)

Mode: WCDMA 1900, Hand SAR, Back Side, Mid.ch

Area Scan (9x12x1): Measurement grid: dx=15mm, dy=15mm

Zoom Scan (5x5x7)/Cube 0: Measurement grid: dx=8mm, dy=8mm, dz=5mm

Reference Value = 25.548 V/m; Power Drift = -0.01 dB

Peak SAR (extrapolated) = 2.021 mW/g

SAR(1 g) = 1.02 mW/g; SAR(10 g) = 0.512 mW/g

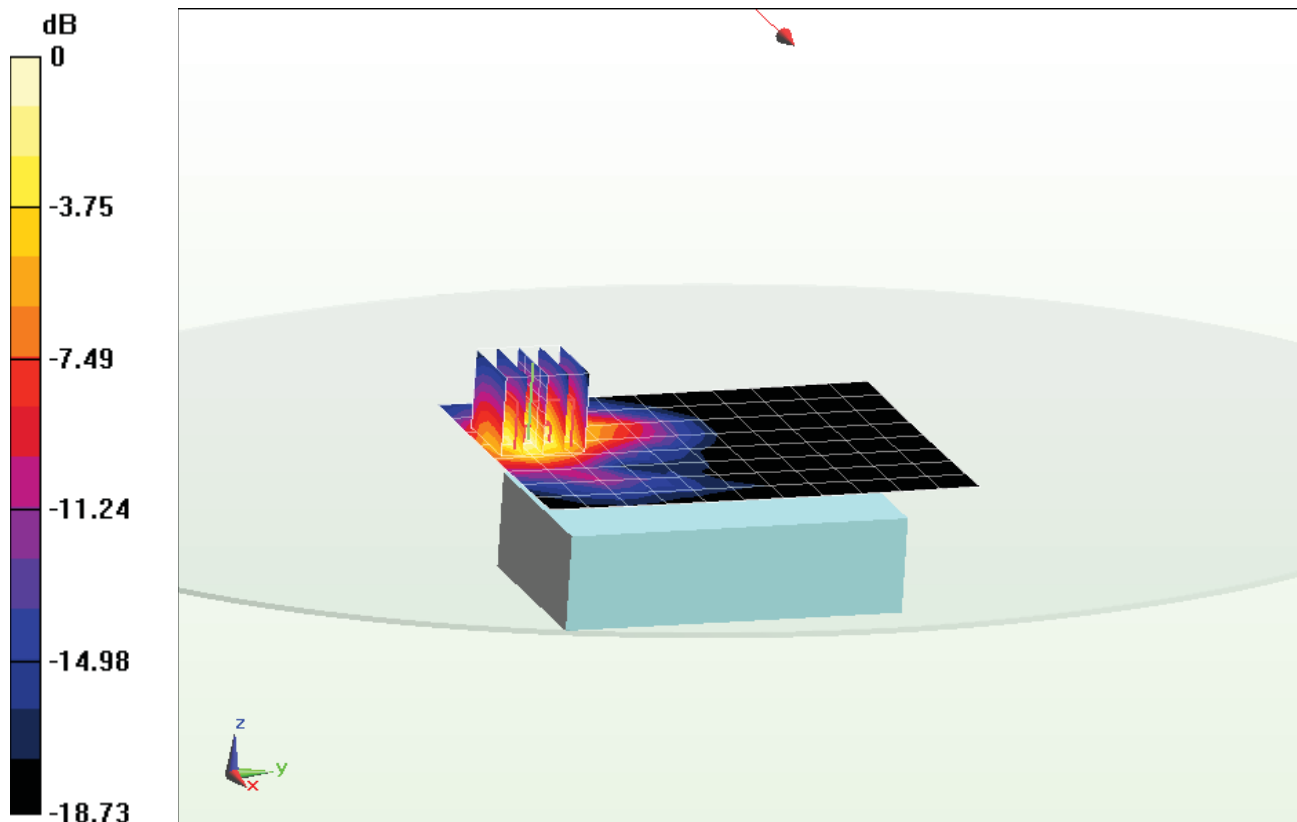

0 dB = 1.12 mW/g = 0.98 dB mW/g

PCTEST ENGINEERING LABORATORY, INC.

EUT: A3LEKGC100A; Type: Portable Camera; Serial: S3GC-0002

Communication System: WCDMA; Frequency: 1907.6 MHz; Duty Cycle: 1:1

Medium: 1900 Body Medium parameters used (interpolated):

$f = 1907.6$ MHz; $\sigma = 1.591$ mho/m; $\epsilon_r = 51.744$; $\rho = 1000$ kg/m³

Phantom section: Flat Section; Space: 0.0 cm

Test Date: 10-04-2012; Ambient Temp: 24.1°C; Tissue Temp: 23.0°C

Probe: ES3DV3 - SN3213; ConvF(4.5, 4.5, 4.5); Calibrated: 4/24/2012;

Sensor-Surface: 4mm (Mechanical Surface Detection)

Electronics: DAE4 Sn1334; Calibrated: 5/7/2012

Phantom: ELI v5.0 Door; Type: QDOVA002BB; Serial: TP-1158

Measurement SW: DASY52, Version 52.8 (1);SEMCAD X Version 14.6.5 (6469)

Mode: WCDMA 1900 HSPA Active, Hand SAR, Front Side, High.ch

Area Scan (9x12x1): Measurement grid: dx=15mm, dy=15mm

Zoom Scan (5x5x7)/Cube 0: Measurement grid: dx=8mm, dy=8mm, dz=5mm

Reference Value = 56.376 V/m; Power Drift = -0.11 dB

Peak SAR (extrapolated) = 13.921 mW/g

SAR(1 g) = 6.66 mW/g; SAR(10 g) = 3.15 mW/g

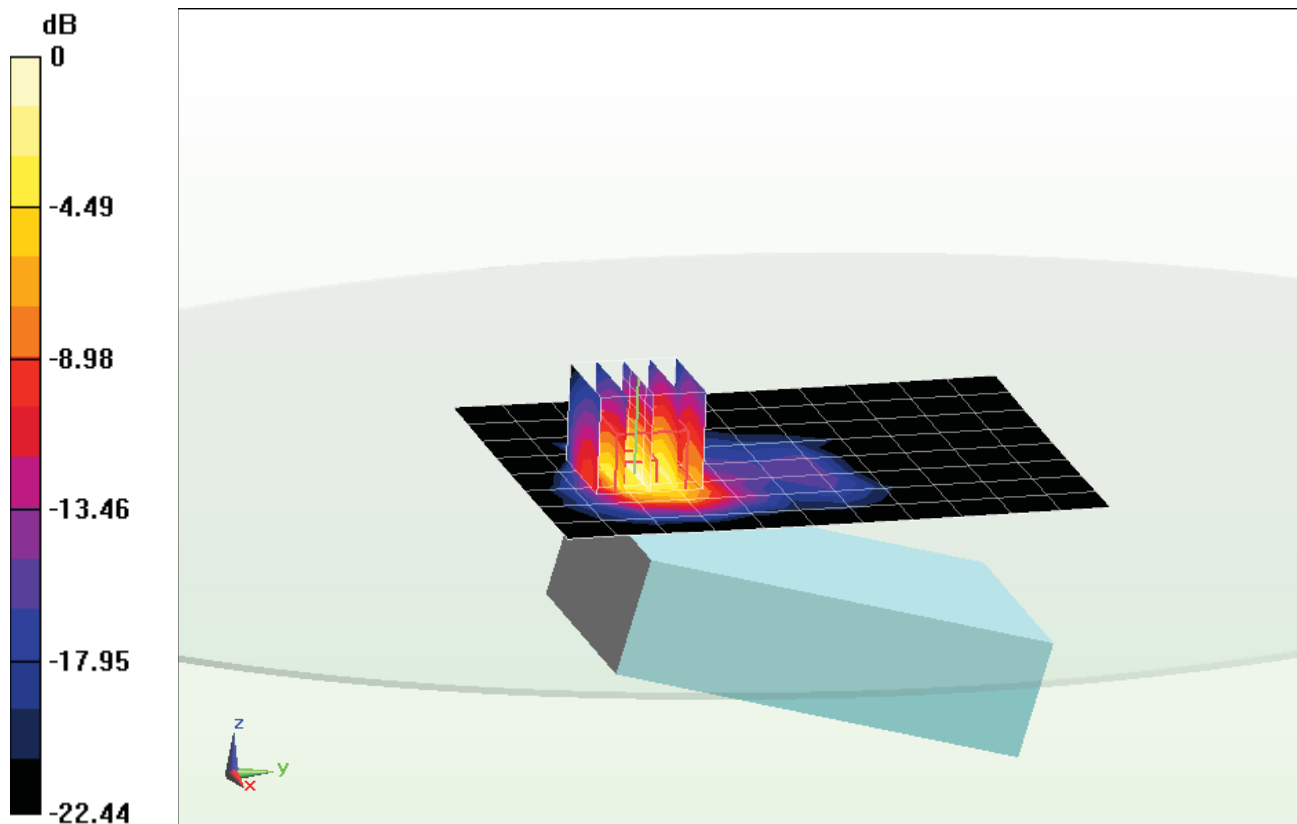

0 dB = 7.66 mW/g = 17.68 dB mW/g

PCTEST ENGINEERING LABORATORY, INC.

EUT: A3LEKGC100A; Type: Portable Camera; Serial: S3GC-0002

Communication System: WCDMA; Frequency: 1880 MHz; Duty Cycle: 1:1

Medium: 1900 Body Medium parameters used:

$f = 1880 \text{ MHz}$; $\sigma = 1.54 \text{ mho/m}$; $\epsilon_r = 52.02$; $\rho = 1000 \text{ kg/m}^3$

Phantom section: Flat Section; Space: 0.0 cm

Test Date: 10-04-2012; Ambient Temp: 24.1°C; Tissue Temp: 23.0°C

Probe: ES3DV3 - SN3213; ConvF(4.5, 4.5, 4.5); Calibrated: 4/24/2012;

Sensor-Surface: 4mm (Mechanical Surface Detection)

Electronics: DAE4 Sn1334; Calibrated: 5/7/2012

Phantom: ELI v5.0 Door; Type: QDOVA002BB; Serial: TP-1158

Measurement SW: DASY52, Version 52.8 (1);SEMCAD X Version 14.6.5 (6469)

Mode: WCDMA 1900, Hand SAR, Bottom Edge, Mid.ch

Area Scan (13x13x1): Measurement grid: $dx=5\text{mm}$, $dy=15\text{mm}$

Zoom Scan (5x5x7)/Cube 0: Measurement grid: $dx=8\text{mm}$, $dy=8\text{mm}$, $dz=5\text{mm}$

Reference Value = 24.514 V/m; Power Drift = 0.06 dB

Peak SAR (extrapolated) = 1.425 mW/g

SAR(1 g) = 0.826 mW/g; SAR(10 g) = 0.445 mW/g

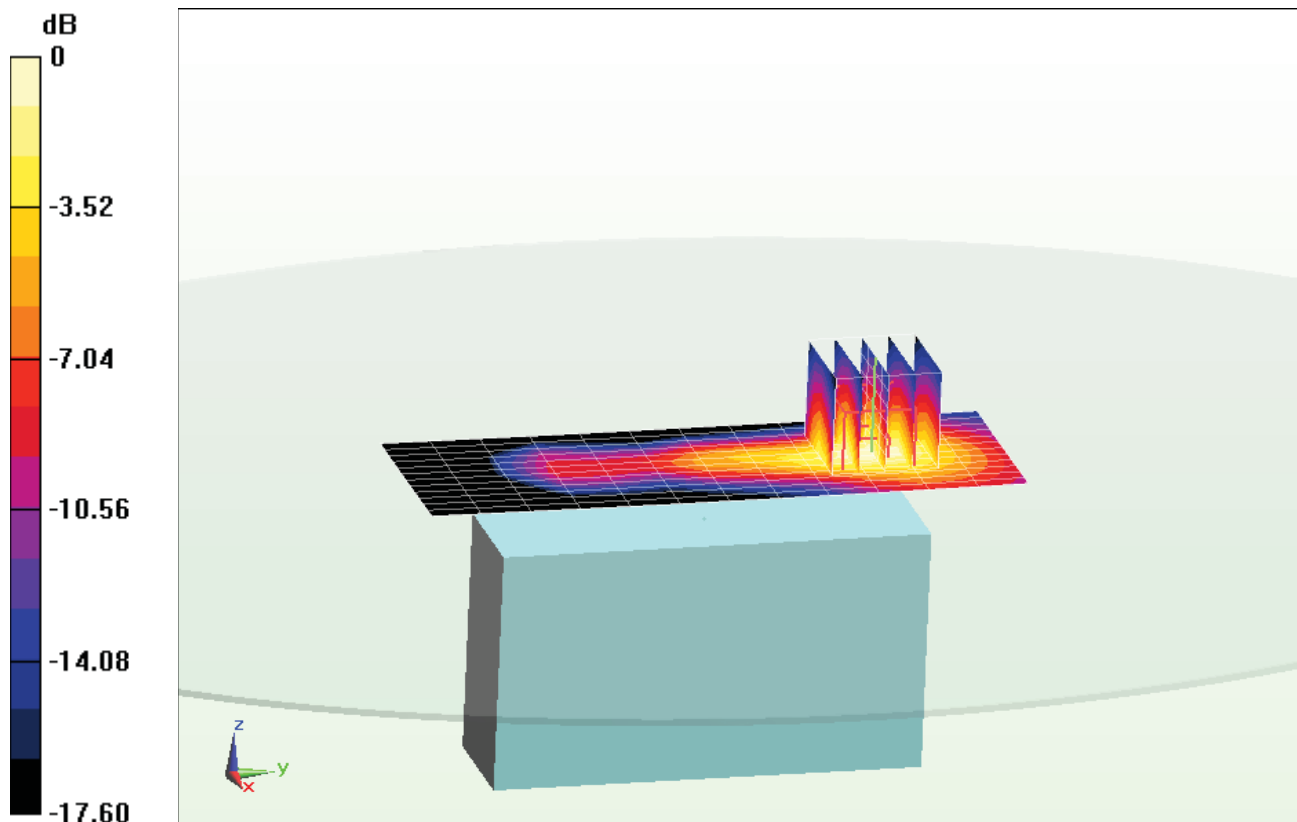

0 dB = 0.934 mW/g = -0.59 dB mW/g

PCTEST ENGINEERING LABORATORY, INC.

EUT: A3LEKGC100A; Type: Portable Camera; Serial: S3GC-0002

Communication System: WCDMA; Frequency: 1907.6 MHz; Duty Cycle: 1:1

Medium: 1900 Body Medium parameters used (interpolated):

$f = 1907.6$ MHz; $\sigma = 1.591$ mho/m; $\epsilon_r = 51.744$; $\rho = 1000$ kg/m³

Phantom section: Flat Section; Space: 0.0 cm

Test Date: 10-04-2012; Ambient Temp: 24.1°C; Tissue Temp: 23.0°C

Probe: ES3DV3 - SN3213; ConvF(4.5, 4.5, 4.5); Calibrated: 4/24/2012;

Sensor-Surface: 4mm (Mechanical Surface Detection)

Electronics: DAE4 Sn1334; Calibrated: 5/7/2012

Phantom: ELI v5.0 Door; Type: QDOVA002BB; Serial: TP-1158

Measurement SW: DASY52, Version 52.8 (1); SEMCAD X Version 14.6.5 (6469)

Mode: WCDMA 1900, Hand SAR, Left Edge, High.ch

Area Scan (13x8x1): Measurement grid: dx=5mm, dy=15mm

Zoom Scan (5x5x7)/Cube 0: Measurement grid: dx=8mm, dy=8mm, dz=5mm

Reference Value = 68.549 V/m; Power Drift = -0.03 dB

Peak SAR (extrapolated) = 14.659 mW/g

SAR(1 g) = 6.69 mW/g; SAR(10 g) = 3 mW/g

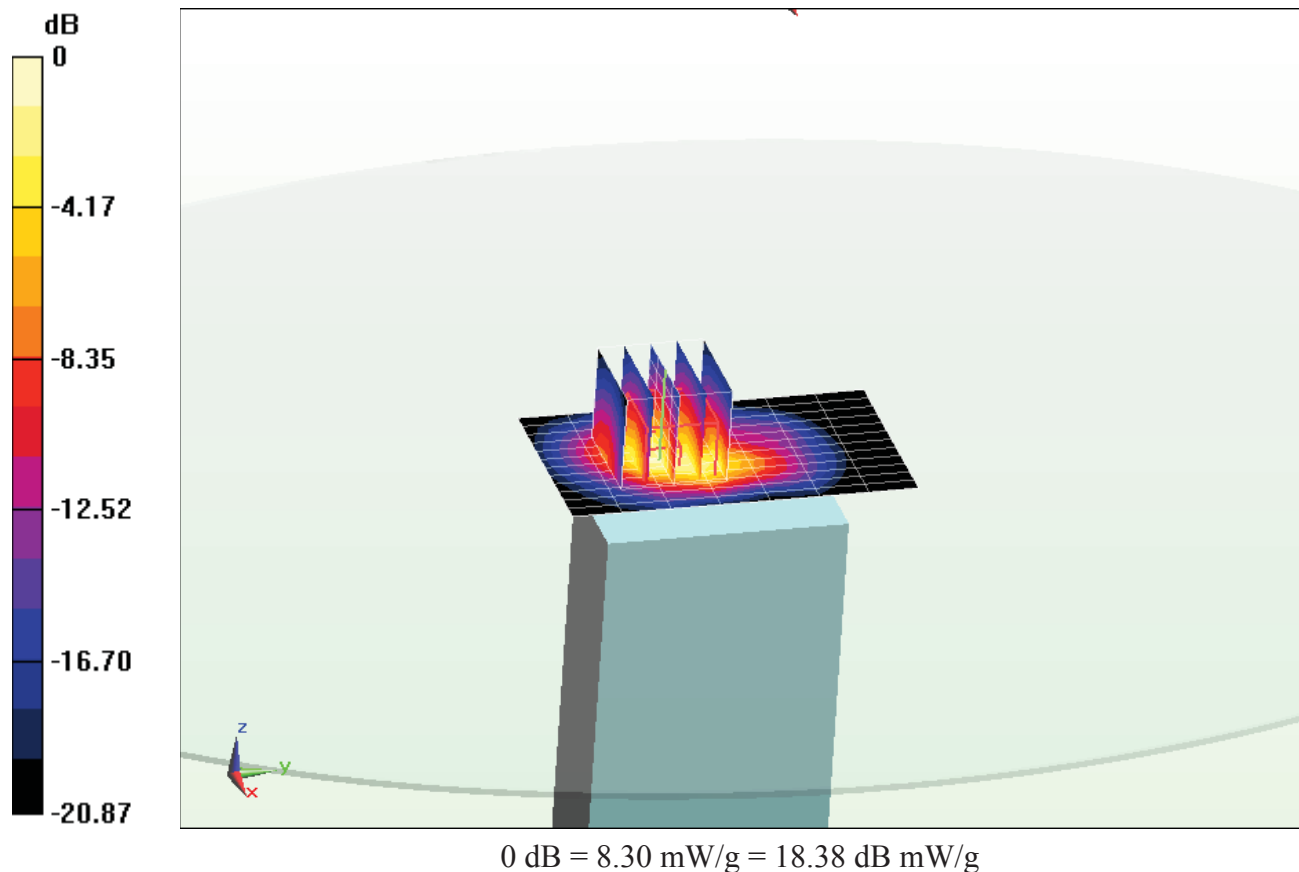

PCTEST ENGINEERING LABORATORY, INC.

EUT: A3LEKGC100A; Type: Portable Camera; Serial: S3GC-0002

Communication System: WCDMA; Frequency: 1880 MHz; Duty Cycle: 1:1
Medium: 1900 Body Medium parameters used:

$$f = 1880 \text{ MHz}; \sigma = 1.54 \text{ mho/m}; \epsilon_r = 52.02; \rho = 1000 \text{ kg/m}^3$$

Phantom section: Flat Section; Space: 1.0 cm

Test Date: 10-04-2012; Ambient Temp: 24.1°C; Tissue Temp: 23.0°C

Probe: ES3DV3 - SN3213; ConvF(4.5, 4.5, 4.5); Calibrated: 4/24/2012;
Sensor-Surface: 4mm (Mechanical Surface Detection)

Electronics: DAE4 Sn1334; Calibrated: 5/7/2012

Phantom: ELI v5.0 Door; Type: QDOVA002BB; Serial: TP-1158

Measurement SW: DASY52, Version 52.8 (1); SEMCAD X Version 14.6.5 (6469)

Mode: WCDMA 1900, Body SAR, Back Side, Mid.ch

Area Scan (7x12x1): Measurement grid: dx=15mm, dy=15mm

Zoom Scan (5x5x7)/Cube 0: Measurement grid: dx=8mm, dy=8mm, dz=5mm

Reference Value = 6.841 V/m; Power Drift = 0.13 dB

Peak SAR (extrapolated) = 0.273 W/kg

SAR(1 g) = 0.165 W/kg; SAR(10 g) = 0.102 W/kg

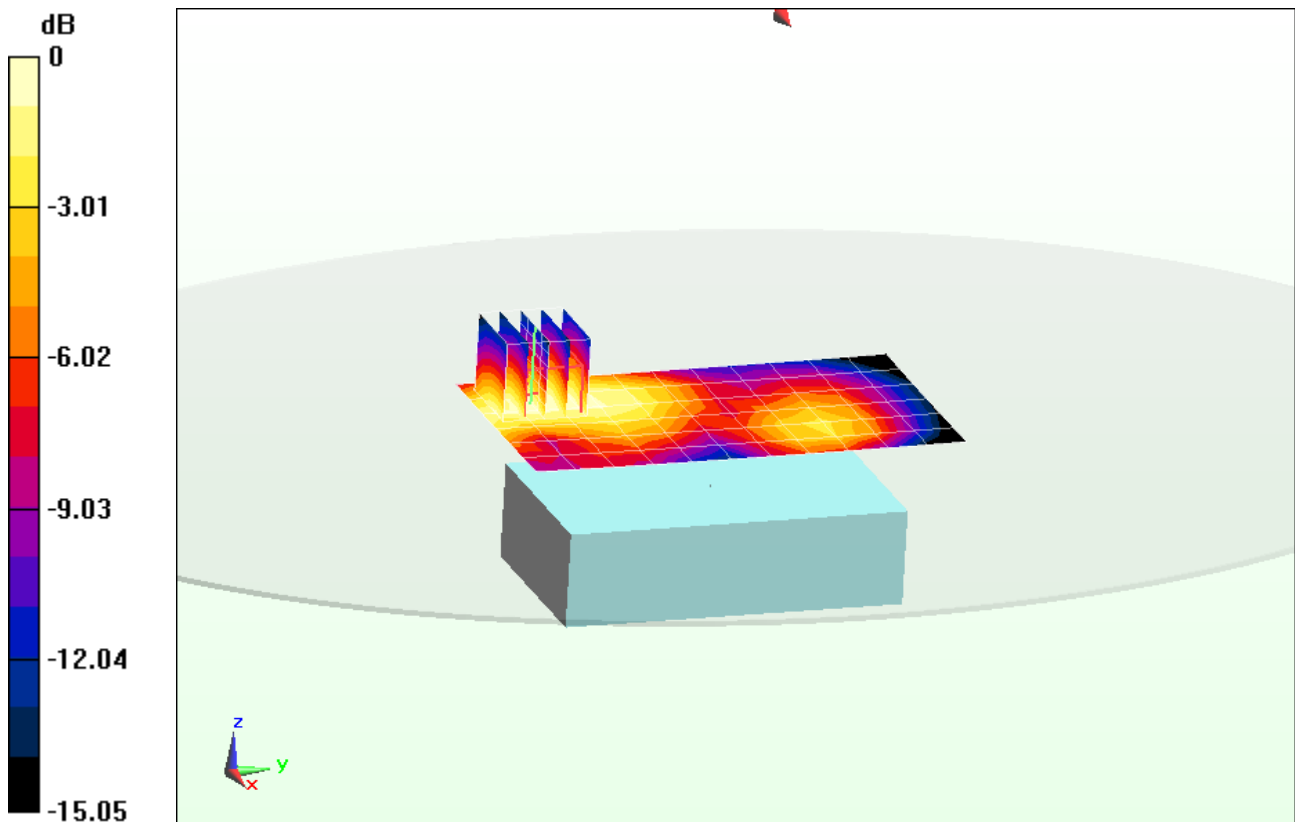

PCTEST ENGINEERING LABORATORY, INC.

EUT: A3LEKGC100A; Type: Portable Camera; Serial: S3GC-0002

Communication System: WCDMA; Frequency: 1907.6 MHz; Duty Cycle: 1:1

Medium: 1900 Medium parameters used (interpolated):

$f = 1907.6 \text{ MHz}$; $\sigma = 1.591 \text{ mho/m}$; $\epsilon_r = 51.744$; $\rho = 1000 \text{ kg/m}^3$

Phantom section: Flat Section; Space: 1.0 cm

Test Date: 10-04-2012; Ambient Temp: 24.1°C; Tissue Temp: 23.0°C

Probe: ES3DV3 - SN3213; ConvF(4.5, 4.5, 4.5); Calibrated: 4/24/2012;

Sensor-Surface: 4mm (Mechanical Surface Detection)

Electronics: DAE4 Sn1334; Calibrated: 5/7/2012

Phantom: ELI v5.0 Door; Type: QDOVA002BB; Serial: TP-1158

Measurement SW: DASY52, Version 52.8 (1); SEMCAD X Version 14.6.5 (6469)

Mode: WCDMA 1900, Body SAR, Front Side, High.ch

Area Scan (7x12x1): Measurement grid: dx=15mm, dy=15mm

Zoom Scan (5x5x7)/Cube 0: Measurement grid: dx=8mm, dy=8mm, dz=5mm

Reference Value = 28.114 V/m; Power Drift = 0.00 dB

Peak SAR (extrapolated) = 1.87 W/kg

SAR(1 g) = 1.1 W/kg; SAR(10 g) = 0.604 W/kg

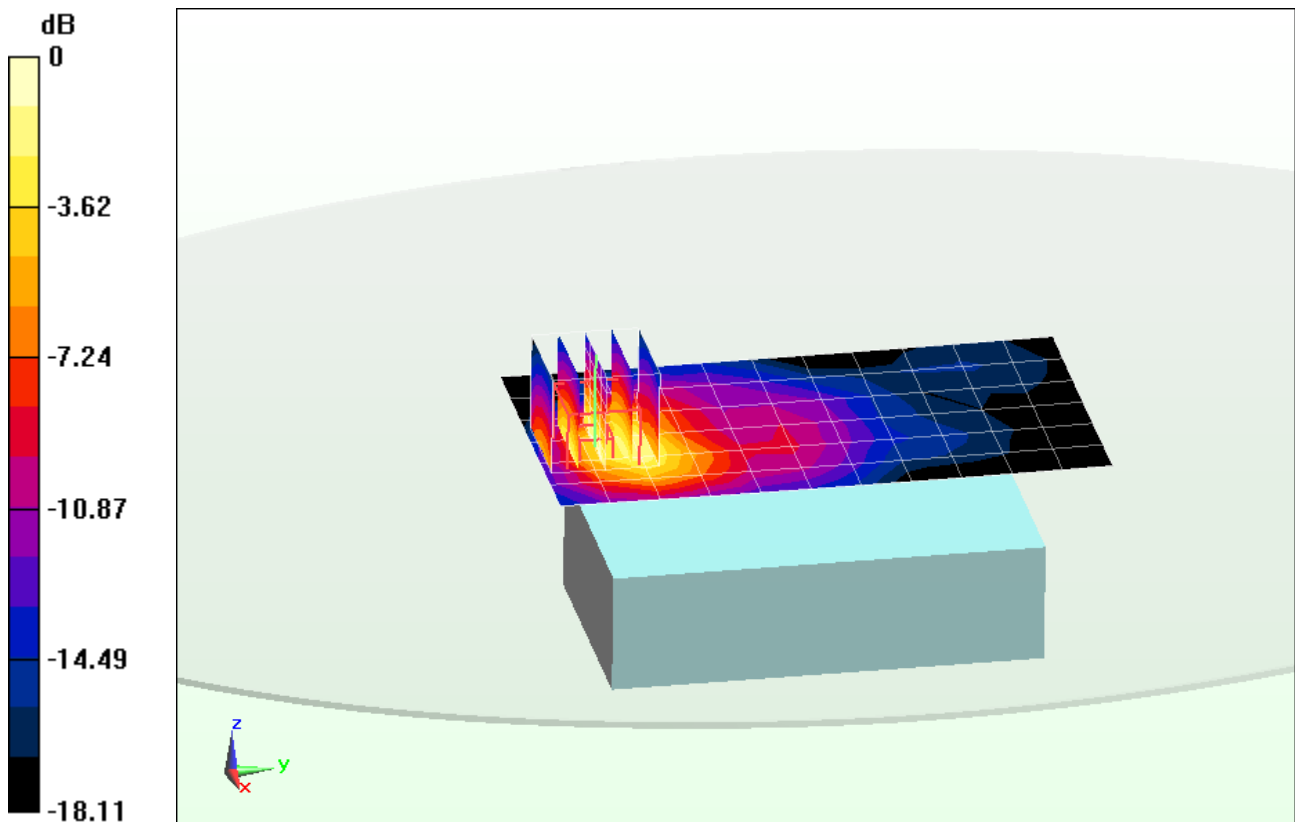

PCTEST ENGINEERING LABORATORY, INC.

EUT: A3LEKGC100A; Type: Portable Camera; Serial: S3GC-0002

Communication System: WCDMA; Frequency: 1880 MHz; Duty Cycle: 1:1
Medium: 1900 Body Medium parameters used:

$$f = 1880 \text{ MHz}; \sigma = 1.54 \text{ mho/m}; \epsilon_r = 52.02; \rho = 1000 \text{ kg/m}^3$$

Phantom section: Flat Section; Space: 1.0 cm

Test Date: 10-04-2012; Ambient Temp: 24.1°C; Tissue Temp: 23.0°C

Probe: ES3DV3 - SN3213; ConvF(4.5, 4.5, 4.5); Calibrated: 4/24/2012;
Sensor-Surface: 4mm (Mechanical Surface Detection)

Electronics: DAE4 Sn1334; Calibrated: 5/7/2012

Phantom: ELI v5.0 Door; Type: QDOVA002BB; Serial: TP-1158

Measurement SW: DASY52, Version 52.8 (1); SEMCAD X Version 14.6.5 (6469)

Mode: WCDMA 1900, Body SAR, Bottom Edge, Mid.ch

Area Scan (11x11x1): Measurement grid: dx=5mm, dy=15mm

Zoom Scan (5x5x7)/Cube 0: Measurement grid: dx=8mm, dy=8mm, dz=5mm

Reference Value = 11.666 V/m; Power Drift = 0.05 dB

Peak SAR (extrapolated) = 0.295 W/kg

SAR(1 g) = 0.189 W/kg; SAR(10 g) = 0.118 W/kg

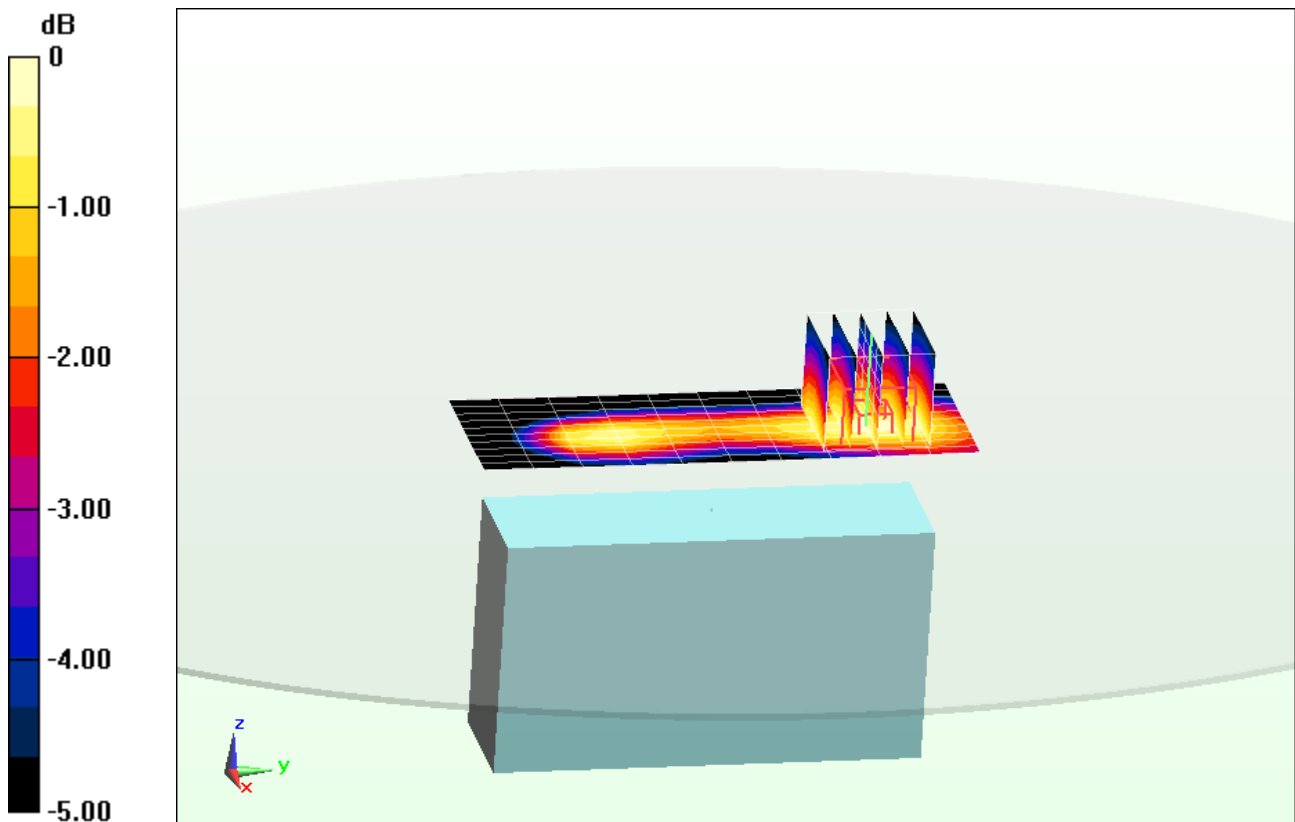

$$0 \text{ dB} = 0.205 \text{ W/kg} = -6.88 \text{ dBW/kg}$$

PCTEST ENGINEERING LABORATORY, INC.

EUT: A3LEKGC100A; Type: Portable Camera; Serial: S3GC-0002

Communication System: WCDMA; Frequency: 1880 MHz; Duty Cycle: 1:1
Medium: 1900 Body Medium parameters used:

$$f = 1880 \text{ MHz}; \sigma = 1.514 \text{ mho/m}; \epsilon_r = 52.6; \rho = 1000 \text{ kg/m}^3$$

Phantom section: Flat Section; Space: 1.0 cm

Test Date: 10-11-2012; Ambient Temp: 23.4°C; Tissue Temp: 22.0°C

Probe: ES3DV3 - SN3213; ConvF(4.5, 4.5, 4.5); Calibrated: 4/24/2012;
Sensor-Surface: 4mm (Mechanical Surface Detection)

Electronics: DAE4 Sn1334; Calibrated: 5/7/2012

Phantom: ELI v5.0 Door; Type: QDOVA002BB; Serial: TP-1158

Measurement SW: DASY52, Version 52.8 (3); SEMCAD X Version 14.6.5 (6469)

Mode: WCDMA 1900, Body SAR, Left Edge, Mid.ch

Area Scan (13x9x1): Measurement grid: dx=5mm, dy=15mm

Zoom Scan (5x5x7)/Cube 0: Measurement grid: dx=8mm, dy=8mm, dz=5mm

Reference Value = 23.410 V/m; Power Drift = -0.03 dB

Peak SAR (extrapolated) = 1.33 W/kg

SAR(1 g) = 0.757 W/kg

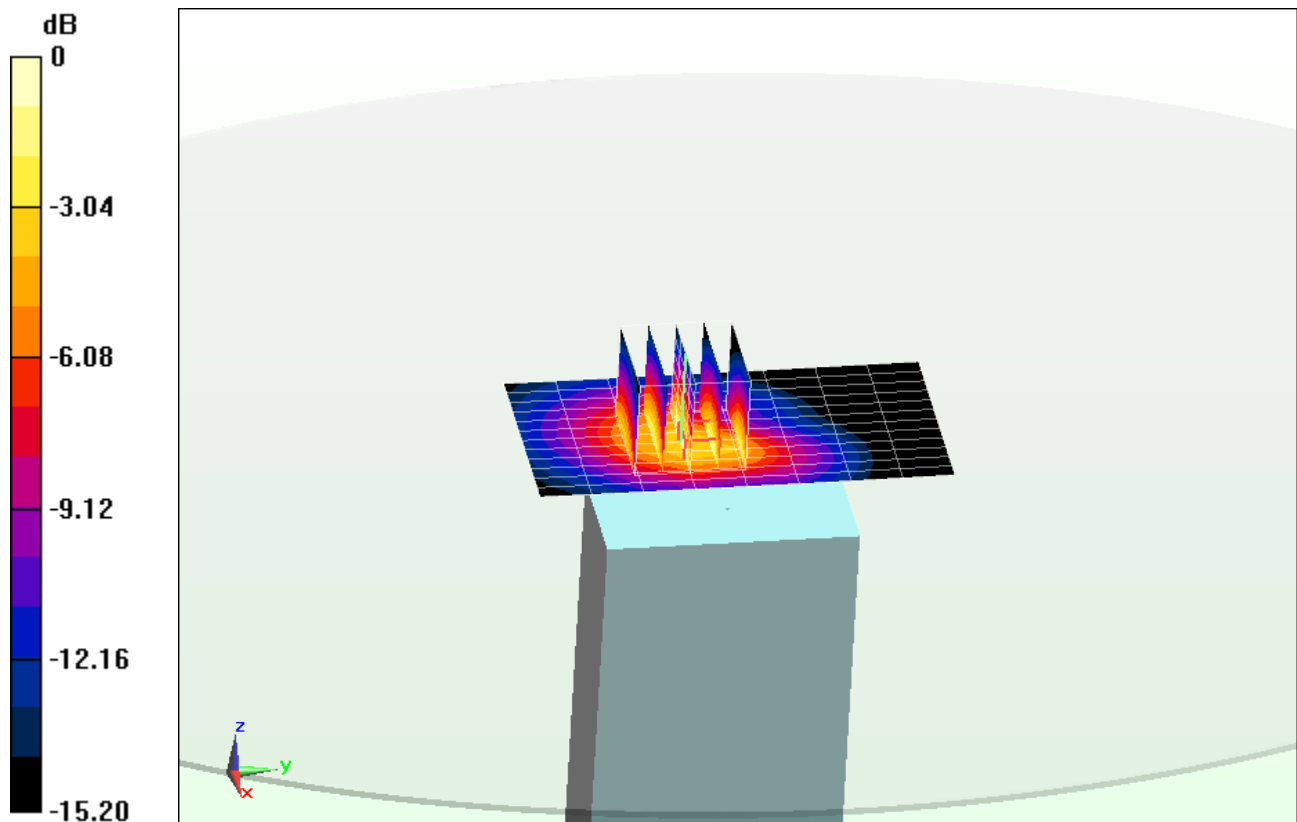

0 dB = 0.798 W/kg = -0.98 dBW/kg

PCTEST ENGINEERING LABORATORY, INC.

EUT: A3LEKGC100A; Type: Portable Camera; Serial: S3GC-0622

Communication System: IEEE 802.11b; Frequency: 2462 MHz; Duty Cycle: 1:1

Medium: 2450 Body Medium parameters used (interpolated):

$f = 2462 \text{ MHz}$; $\sigma = 2.001 \text{ mho/m}$; $\epsilon_r = 51.065$; $\rho = 1000 \text{ kg/m}^3$

Phantom section: Flat Section; Space: 0.0 cm

Test Date: 08-24-2012; Ambient Temp: 23.1°C; Tissue Temp: 22.9°C

Probe: EX3DV4 - SN3561; ConvF(6.22, 6.22, 6.22); Calibrated: 7/26/2012;

Sensor-Surface: 3mm (Mechanical Surface Detection)

Electronics: DAE4 Sn665; Calibrated: 4/19/2012

Phantom: SAM with CRP; Type: SAM; Serial: TP1375

Measurement SW: DASY4, Version 4.7 (80); SEMCAD X Version 14.6.5 (6469)

Mode: IEEE 802.11b, Hand SAR, Ch 11, 1 Mbps, Back Side

Area Scan (10x15x1): Measurement grid: dx=12mm, dy=12mm

Zoom Scan (7x7x7)/Cube 0: Measurement grid: dx=5mm, dy=5mm, dz=5mm

Reference Value = 5.000 V/m; Power Drift = -0.20 dB

Peak SAR (extrapolated) = 0.126 mW/g

SAR(1 g) = 0.044 mW/g; SAR(10 g) = 0.017 mW/g

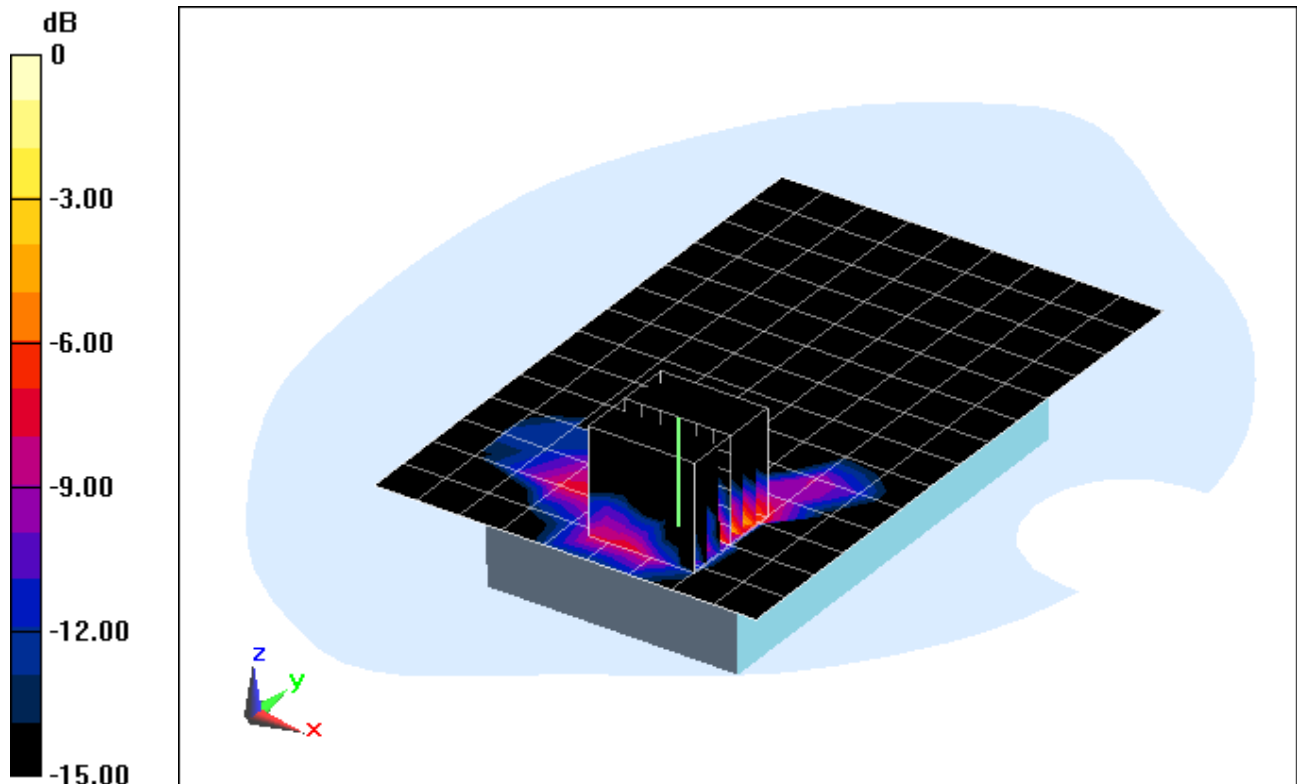

0 dB = 0.0621 mW/g = -24.14 dB mW/g

PCTEST ENGINEERING LABORATORY, INC.

EUT: A3LEKGC100A; Type: Portable Camera; Serial: S3GC-0622

Communication System: IEEE 802.11b; Frequency: 2462 MHz; Duty Cycle: 1:1

Medium: 2450 Body Medium parameters used (interpolated):

$f = 2462 \text{ MHz}$; $\sigma = 2.001 \text{ mho/m}$; $\epsilon_r = 51.065$; $\rho = 1000 \text{ kg/m}^3$

Phantom section: Flat Section; Space: 0.0 cm

Test Date: 08-24-2012; Ambient Temp: 23.1°C; Tissue Temp: 22.9°C

Probe: EX3DV4 - SN3561; ConvF(6.22, 6.22, 6.22); Calibrated: 7/26/2012;

Sensor-Surface: 3mm (Mechanical Surface Detection)

Electronics: DAE4 Sn665; Calibrated: 4/19/2012

Phantom: SAM with CRP; Type: SAM; Serial: TP1375

Measurement SW: DASY4, Version 4.7 (80); SEMCAD X Version 14.6.5 (6469)

Mode: IEEE 802.11b, Hand SAR, Ch 11, 1 Mbps, Front Side

Area Scan (10x15x1): Measurement grid: dx=12mm, dy=12mm

Zoom Scan (7x7x7)/Cube 0: Measurement grid: dx=5mm, dy=5mm, dz=5mm

Reference Value = 9.739 V/m; Power Drift = -0.00 dB

Peak SAR (extrapolated) = 0.591 mW/g

SAR(1 g) = 0.206 mW/g; SAR(10 g) = 0.083 mW/g

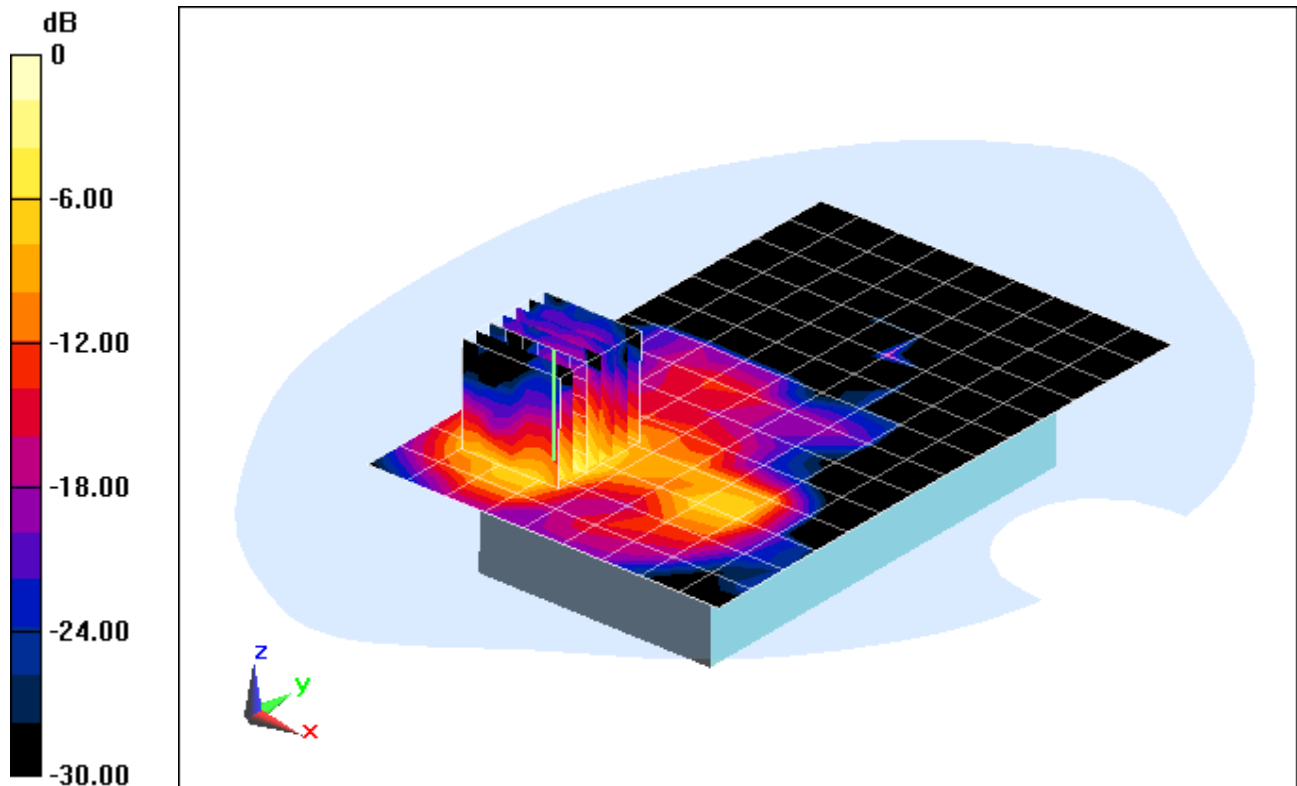

0 dB = 0.328 mW/g = -9.68 dB mW/g

PCTEST ENGINEERING LABORATORY, INC.

EUT: A3LEKGC100A; Type: Portable Camera; Serial: S3GC-0622

Communication System: IEEE 802.11b; Frequency: 2462 MHz; Duty Cycle: 1:1

Medium: 2450 Body Medium parameters used (interpolated):

$f = 2462 \text{ MHz}$; $\sigma = 2.001 \text{ mho/m}$; $\epsilon_r = 51.065$; $\rho = 1000 \text{ kg/m}^3$

Phantom section: Flat Section; Space: 0.0 cm

Test Date: 08-24-2012; Ambient Temp: 23.1°C; Tissue Temp: 22.9°C

Probe: EX3DV4 - SN3561; ConvF(6.22, 6.22, 6.22); Calibrated: 7/26/2012;

Sensor-Surface: 3mm (Mechanical Surface Detection)

Electronics: DAE4 Sn665; Calibrated: 4/19/2012

Phantom: SAM with CRP; Type: SAM; Serial: TP1375

Measurement SW: DASY4, Version 4.7 (80); SEMCAD X Version 14.6.5 (6469)

Mode: IEEE 802.11b, Hand SAR, Ch 11, 1 Mbps, Top Edge

Area Scan (12x15x1): Measurement grid: $dx=5\text{mm}$, $dy=12\text{mm}$

Zoom Scan (7x7x7)/Cube 0: Measurement grid: $dx=5\text{mm}$, $dy=5\text{mm}$, $dz=5\text{mm}$

Reference Value = 5.304 V/m; Power Drift = 0.13 dB

Peak SAR (extrapolated) = 0.122 mW/g

SAR(1 g) = 0.064 mW/g; SAR(10 g) = 0.030 mW/g

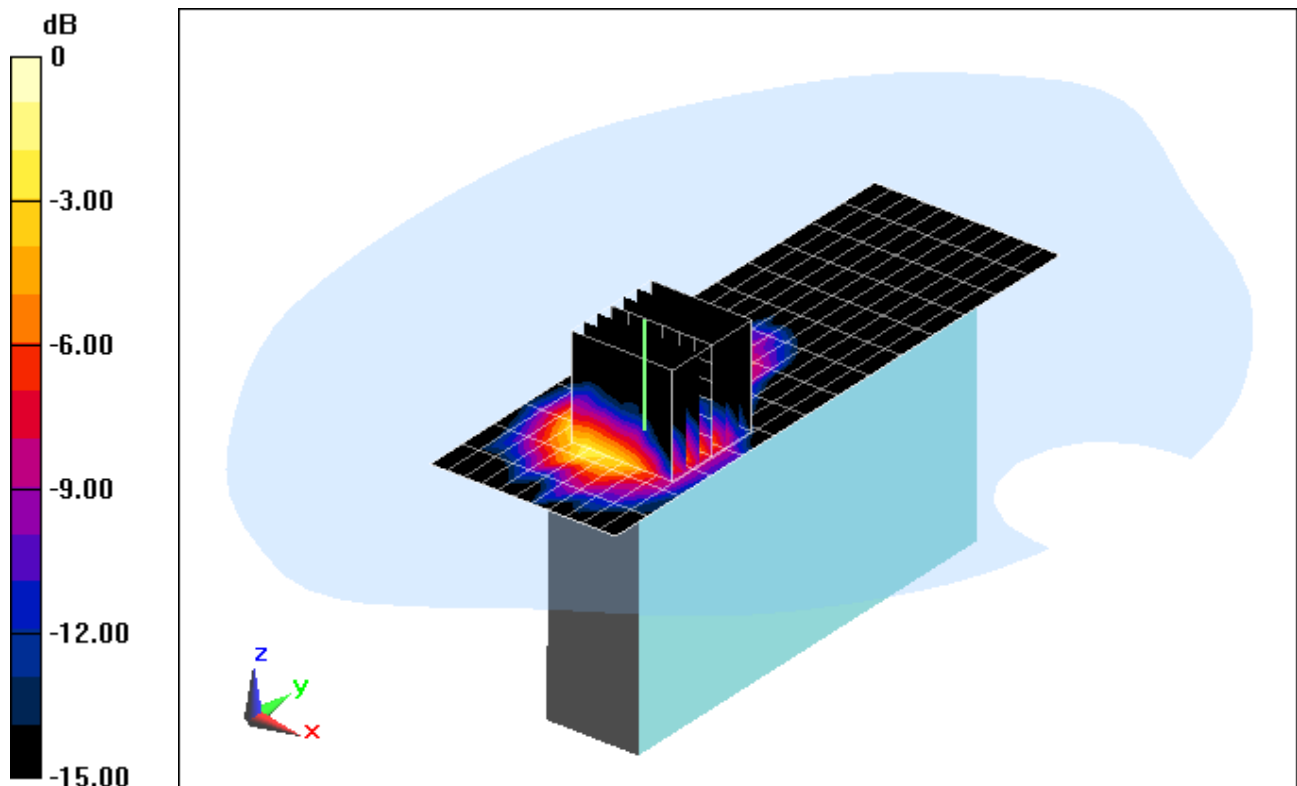

0 dB = 0.0821 mW/g = -21.71 dB mW/g

PCTEST ENGINEERING LABORATORY, INC.

EUT: A3LEKGC100A; Type: Portable Camera; Serial: S3GC-0622

Communication System: IEEE 802.11b; Frequency: 2462 MHz; Duty Cycle: 1:1

Medium: 2450 Body Medium parameters used (interpolated):

$f = 2462 \text{ MHz}$; $\sigma = 2.001 \text{ mho/m}$; $\epsilon_r = 51.065$; $\rho = 1000 \text{ kg/m}^3$

Phantom section: Flat Section; Space: 0.0 cm

Test Date: 08-24-2012; Ambient Temp: 23.1°C; Tissue Temp: 22.9°C

Probe: EX3DV4 - SN3561; ConvF(6.22, 6.22, 6.22); Calibrated: 7/26/2012;

Sensor-Surface: 3mm (Mechanical Surface Detection)

Electronics: DAE4 Sn665; Calibrated: 4/19/2012

Phantom: SAM with CRP; Type: SAM; Serial: TP1375

Measurement SW: DASY4, Version 4.7 (80); SEMCAD X Version 14.6.5 (6469)

Mode: IEEE 802.11b, Hand SAR, Ch 11, 1 Mbps, Left Edge

Area Scan (14x9x1): Measurement grid: $dx=5\text{mm}$, $dy=12\text{mm}$

Zoom Scan (7x7x7)/Cube 0: Measurement grid: $dx=5\text{mm}$, $dy=5\text{mm}$, $dz=5\text{mm}$

Reference Value = 16.659 V/m; Power Drift = -0.06 dB

Peak SAR (extrapolated) = 1.825 mW/g

SAR(1 g) = 0.528 mW/g; SAR(10 g) = 0.180 mW/g

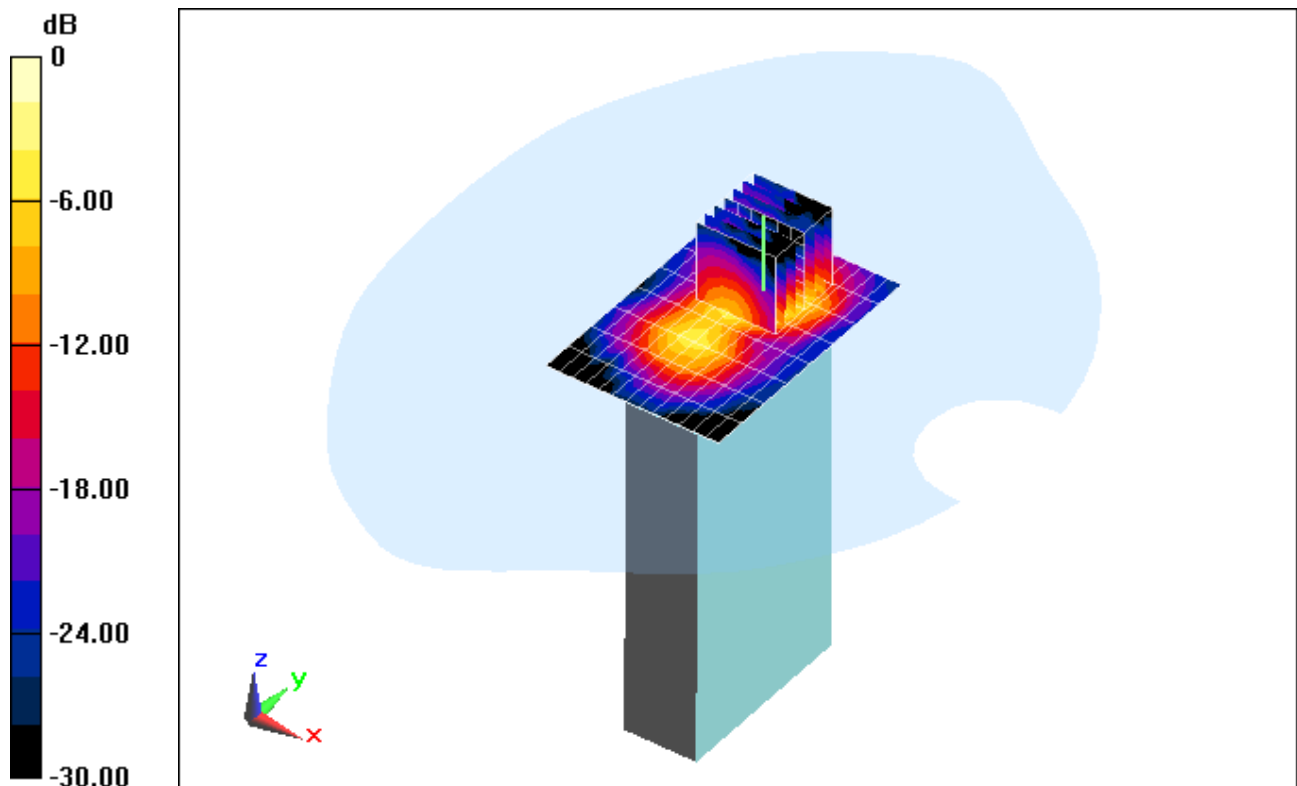

0 dB = 0.804 mW/g = -1.89 dB mW/g

PCTEST ENGINEERING LABORATORY, INC.

EUT: A3LEKGC100A; Type: Portable Camera; Serial: S3GC-0622

Communication System: IEEE 802.11b; Frequency: 2462 MHz; Duty Cycle: 1:1

Medium: 2450 Body Medium parameters used (interpolated):

$f = 2462 \text{ MHz}$; $\sigma = 2.001 \text{ mho/m}$; $\epsilon_r = 51.065$; $\rho = 1000 \text{ kg/m}^3$

Phantom section: Flat Section; Space: 1.0 cm

Test Date: 08-24-2012; Ambient Temp: 23.1°C; Tissue Temp: 22.9°C

Probe: EX3DV4 - SN3561; ConvF(6.22, 6.22, 6.22); Calibrated: 7/26/2012;

Sensor-Surface: 3mm (Mechanical Surface Detection)

Electronics: DAE4 Sn665; Calibrated: 4/19/2012

Phantom: SAM with CRP; Type: SAM; Serial: TP1375

Measurement SW: DASY4, Version 4.7 (80); SEMCAD X Version 14.6.5 (6469)

Mode: IEEE 802.11b, Body SAR, Ch 11, 1 Mbps, Back Side

Area Scan (10x15x1): Measurement grid: dx=12mm, dy=12mm

Zoom Scan (7x7x7)/Cube 0: Measurement grid: dx=5mm, dy=5mm, dz=5mm

Reference Value = 2.282 V/m; Power Drift = 0.19 dB

Peak SAR (extrapolated) = 0.023 mW/g

SAR(1 g) = 0.011 mW/g; SAR(10 g) = 0.00455 mW/g

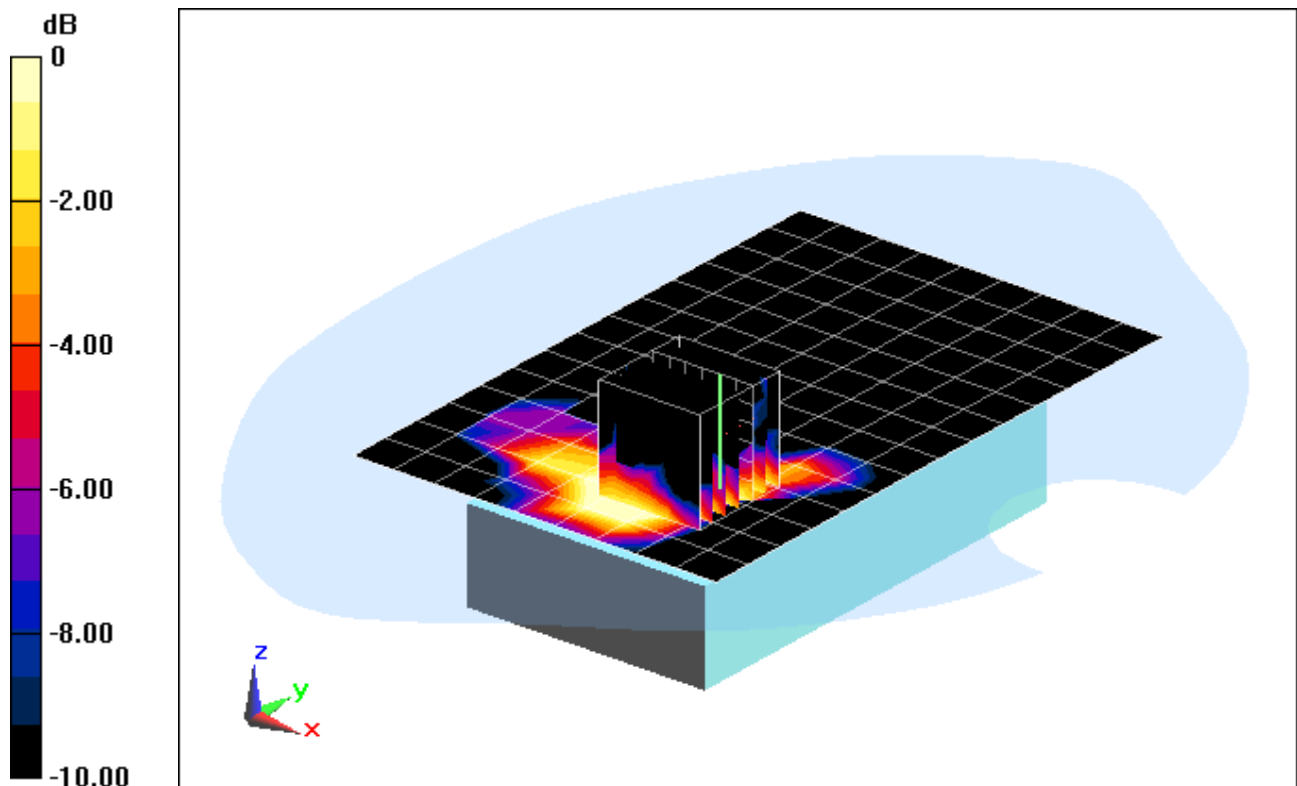

0 dB = 0.0155 mW/g = -36.19 dB mW/g

PCTEST ENGINEERING LABORATORY, INC.

EUT: A3LEKGC100A; Type: Portable Camera; Serial: S3GC-0622

Communication System: IEEE 802.11b; Frequency: 2462 MHz; Duty Cycle: 1:1

Medium: 2450 Body Medium parameters used (interpolated):

$f = 2462 \text{ MHz}$; $\sigma = 2.001 \text{ mho/m}$; $\epsilon_r = 51.065$; $\rho = 1000 \text{ kg/m}^3$

Phantom section: Flat Section; Space: 1.0 cm

Test Date: 08-24-2012; Ambient Temp: 23.1°C; Tissue Temp: 22.9°C

Probe: EX3DV4 - SN3561; ConvF(6.22, 6.22, 6.22); Calibrated: 7/26/2012;

Sensor-Surface: 3mm (Mechanical Surface Detection)

Electronics: DAE4 Sn665; Calibrated: 4/19/2012

Phantom: SAM with CRP; Type: SAM; Serial: TP1375

Measurement SW: DASY4, Version 4.7 (80); SEMCAD X Version 14.6.5 (6469)

Mode: IEEE 802.11b, Body SAR, Ch 11, 1 Mbps, Front Side

Area Scan (10x15x1): Measurement grid: dx=12mm, dy=12mm

Zoom Scan (7x7x7)/Cube 0: Measurement grid: dx=5mm, dy=5mm, dz=5mm

Reference Value = 3.118 V/m; Power Drift = -0.20 dB

Peak SAR (extrapolated) = 0.034 mW/g

SAR(1 g) = 0.017 mW/g; SAR(10 g) = 0.00694 mW/g

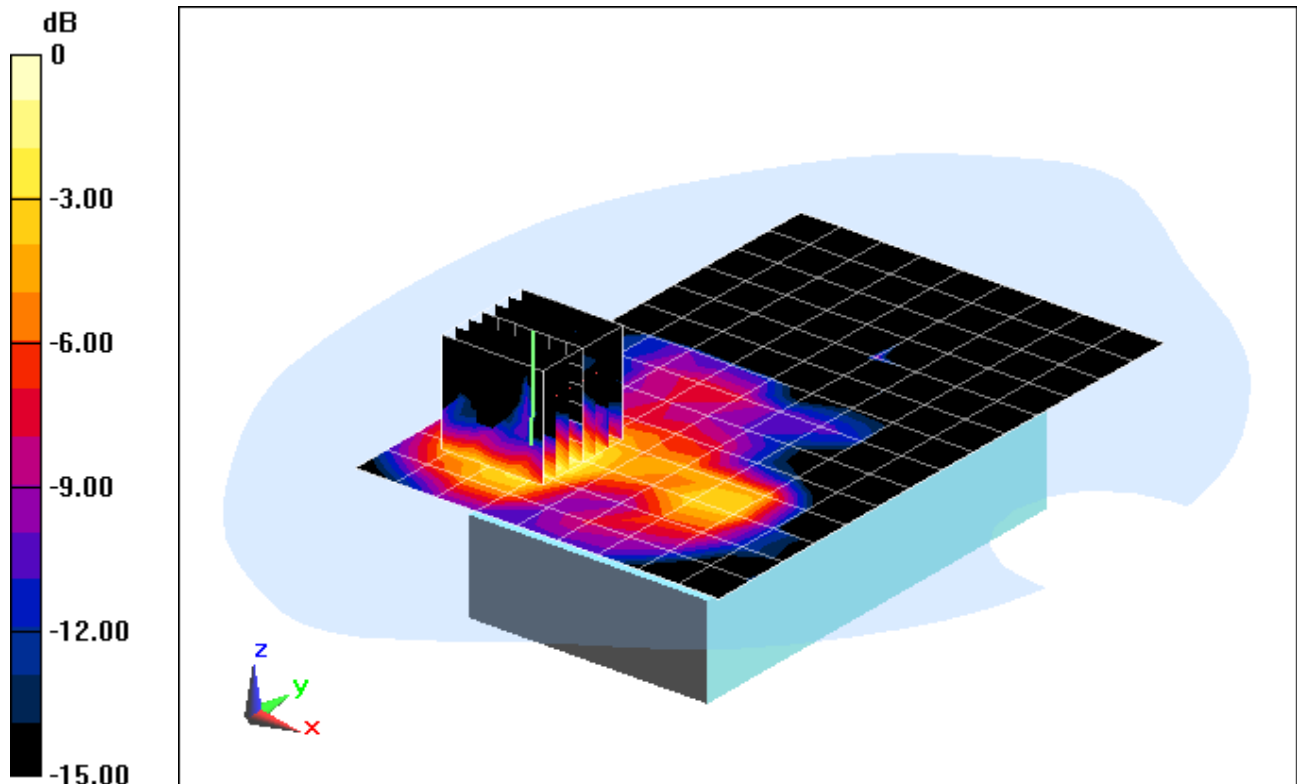

0 dB = 0.0237 mW/g = -32.51 dB mW/g

PCTEST ENGINEERING LABORATORY, INC.

EUT: A3LEKGC100A; Type: Portable Camera; Serial: S3GC-0622

Communication System: IEEE 802.11b; Frequency: 2462 MHz; Duty Cycle: 1:1

Medium: 2450 Body Medium parameters used (interpolated):

$f = 2462 \text{ MHz}$; $\sigma = 2.001 \text{ mho/m}$; $\epsilon_r = 51.065$; $\rho = 1000 \text{ kg/m}^3$

Phantom section: Flat Section; Space: 1.0 cm

Test Date: 08-24-2012; Ambient Temp: 23.1°C; Tissue Temp: 22.9°C

Probe: EX3DV4 - SN3561; ConvF(6.22, 6.22, 6.22); Calibrated: 7/26/2012;

Sensor-Surface: 3mm (Mechanical Surface Detection)

Electronics: DAE4 Sn665; Calibrated: 4/19/2012

Phantom: SAM with CRP; Type: SAM; Serial: TP1375

Measurement SW: DASY4, Version 4.7 (80); SEMCAD X Version 14.6.5 (6469)

Mode: IEEE 802.11b, Body SAR, Ch 11, 1 Mbps, Top Edge

Area Scan (12x15x1): Measurement grid: dx=5mm, dy=12mm

Zoom Scan (7x7x7)/Cube 0: Measurement grid: dx=5mm, dy=5mm, dz=5mm

Reference Value = 1.600 V/m; Power Drift = -0.16 dB

Peak SAR (extrapolated) = 0.045 mW/g

SAR(1 g) = 0.00804 mW/g; SAR(10 g) = 0.00211 mW/g

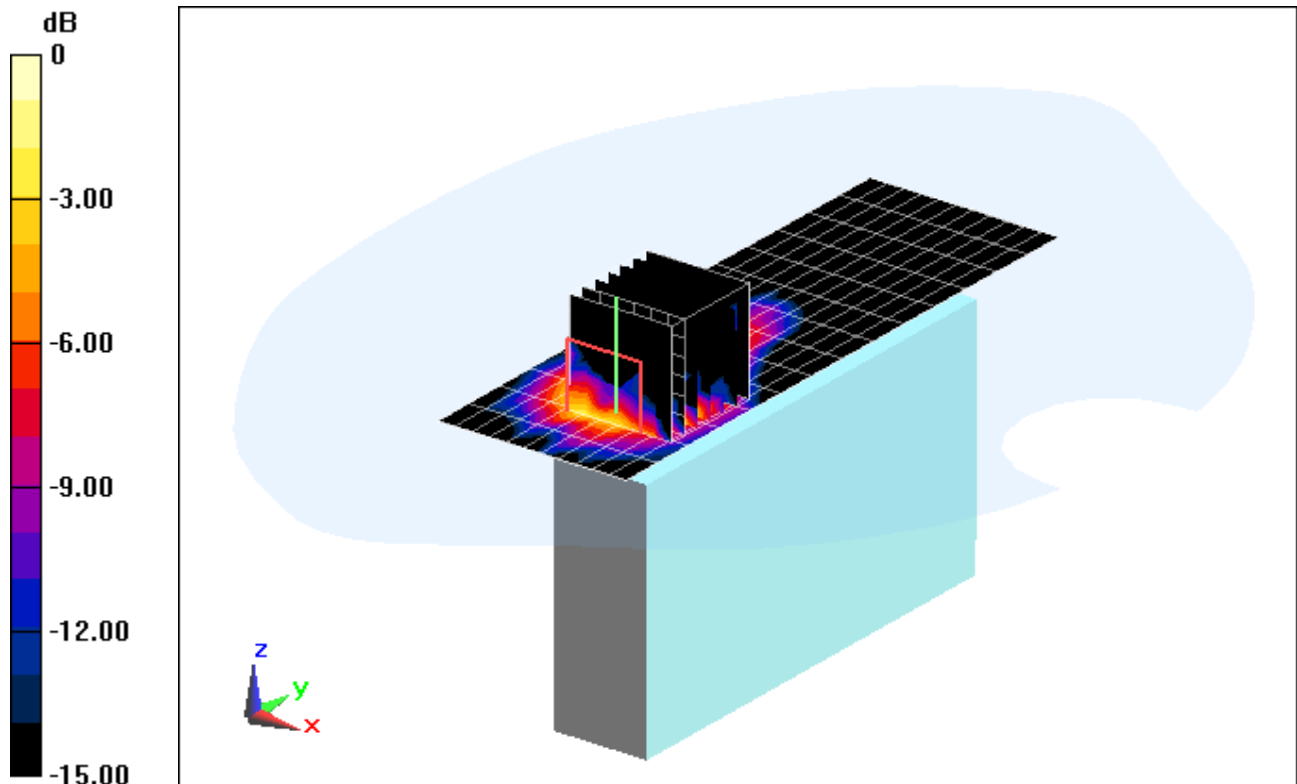

0 dB = 0.0723 mW/g = -22.82 dB mW/g

PCTEST ENGINEERING LABORATORY, INC.

EUT: A3LEKGC100A; Type: Portable Camera; Serial: S3GC-0622

Communication System: IEEE 802.11b; Frequency: 2462 MHz; Duty Cycle: 1:1

Medium: 2450 Body Medium parameters used (interpolated):

$f = 2462 \text{ MHz}$; $\sigma = 2.001 \text{ mho/m}$; $\epsilon_r = 51.065$; $\rho = 1000 \text{ kg/m}^3$

Phantom section: Flat Section; Space: 1.0 cm

Test Date: 08-24-2012; Ambient Temp: 23.1°C; Tissue Temp: 22.9°C

Probe: EX3DV4 - SN3561; ConvF(6.22, 6.22, 6.22); Calibrated: 7/26/2012;

Sensor-Surface: 3mm (Mechanical Surface Detection)

Electronics: DAE4 Sn665; Calibrated: 4/19/2012

Phantom: SAM with CRP; Type: SAM; Serial: TP1375

Measurement SW: DASY4, Version 4.7 (80); SEMCAD X Version 14.6.5 (6469)

Mode: IEEE 802.11b, Body SAR, Ch 11, 1 Mbps, Left Edge

Area Scan (14x9x1): Measurement grid: $dx=5\text{mm}$, $dy=12\text{mm}$

Zoom Scan (7x7x7)/Cube 0: Measurement grid: $dx=5\text{mm}$, $dy=5\text{mm}$, $dz=5\text{mm}$

Reference Value = 3.946 V/m; Power Drift = 0.16 dB

Peak SAR (extrapolated) = 0.057 mW/g

SAR(1 g) = 0.028 mW/g; SAR(10 g) = 0.011 mW/g

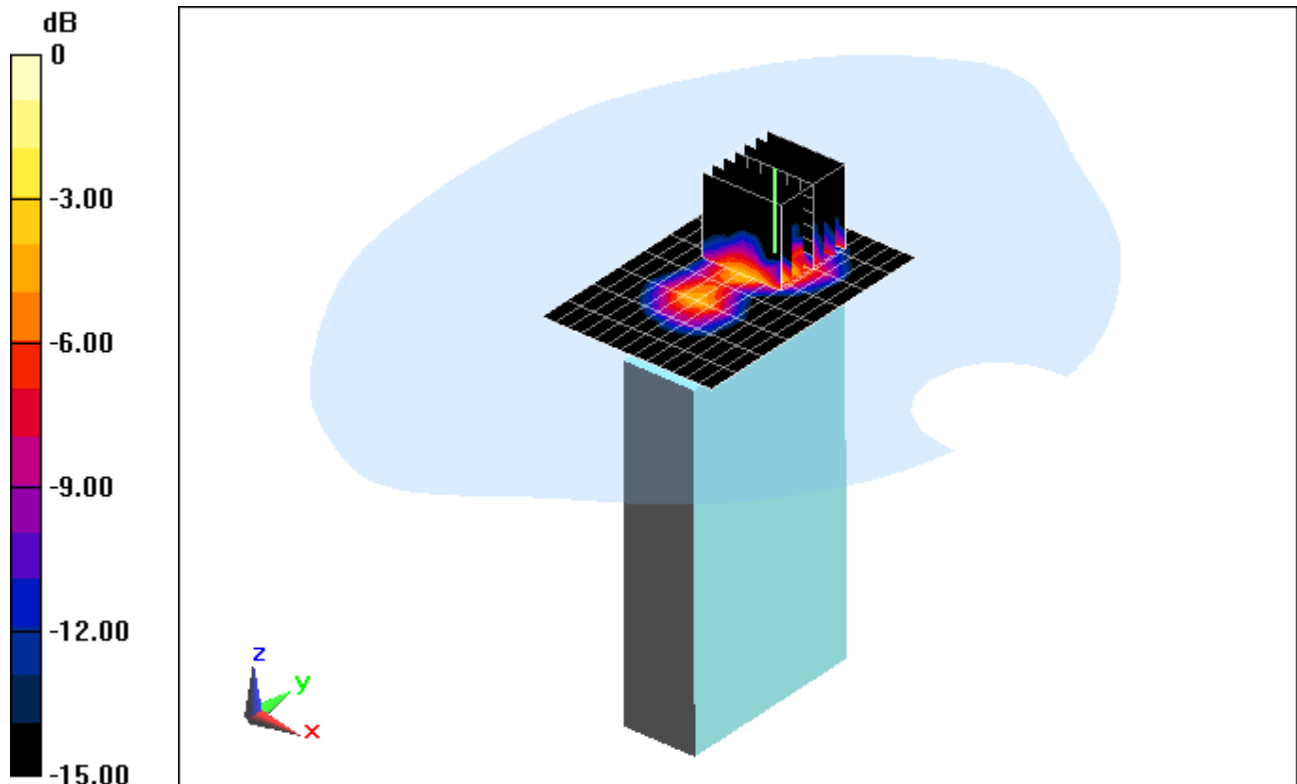

0 dB = 0.707 mW/g = -3.01 dB mW/g

PCTEST ENGINEERING LABORATORY, INC.

EUT: A3LEKGC100A; Type: Portable Camera; Serial: S3GC-0622

Communication System: IEEE 802.11a 5.2-5.8 GHz Band; Frequency: 5520 MHz; Duty Cycle: 1:1

Medium: 5GHz Body Medium parameters used:

$f = 5520 \text{ MHz}$; $\sigma = 5.697 \text{ mho/m}$; $\epsilon_r = 47.3$; $\rho = 1000 \text{ kg/m}^3$

Phantom section: Flat Section; Space: 0.0 cm

Test Date: 08-27-2012; Ambient Temp: 24.5°C; Tissue Temp: 23.4°C

Probe: EX3DV4 - SN3589; ConvF(3.4, 3.4, 3.4); Calibrated: 1/27/2012;

Sensor-Surface: 2mm (Mechanical Surface Detection)

Electronics: DAE4 Sn1323; Calibrated: 2/15/2012

Phantom: SAM Main; Type: SAM 4.0; Serial: TP-1114

Measurement SW: DASY4, Version 4.7 (80); SEMCAD X Version 14.6.5 (6469)

Mode: IEEE 802.11a, 5.5 GHz, Hand SAR, Ch 104, 6 Mbps, Back Side

Area Scan (13x18x1): Measurement grid: dx=10mm, dy=10mm

Zoom Scan (9x9x12)/Cube 0: Measurement grid: dx=4mm, dy=4mm, dz=2mm

Reference Value = 6.772 V/m; Power Drift = 0.21 dB

Peak SAR (extrapolated) = 0.811 mW/g

SAR(1 g) = 0.186 mW/g; SAR(10 g) = 0.054 mW/g

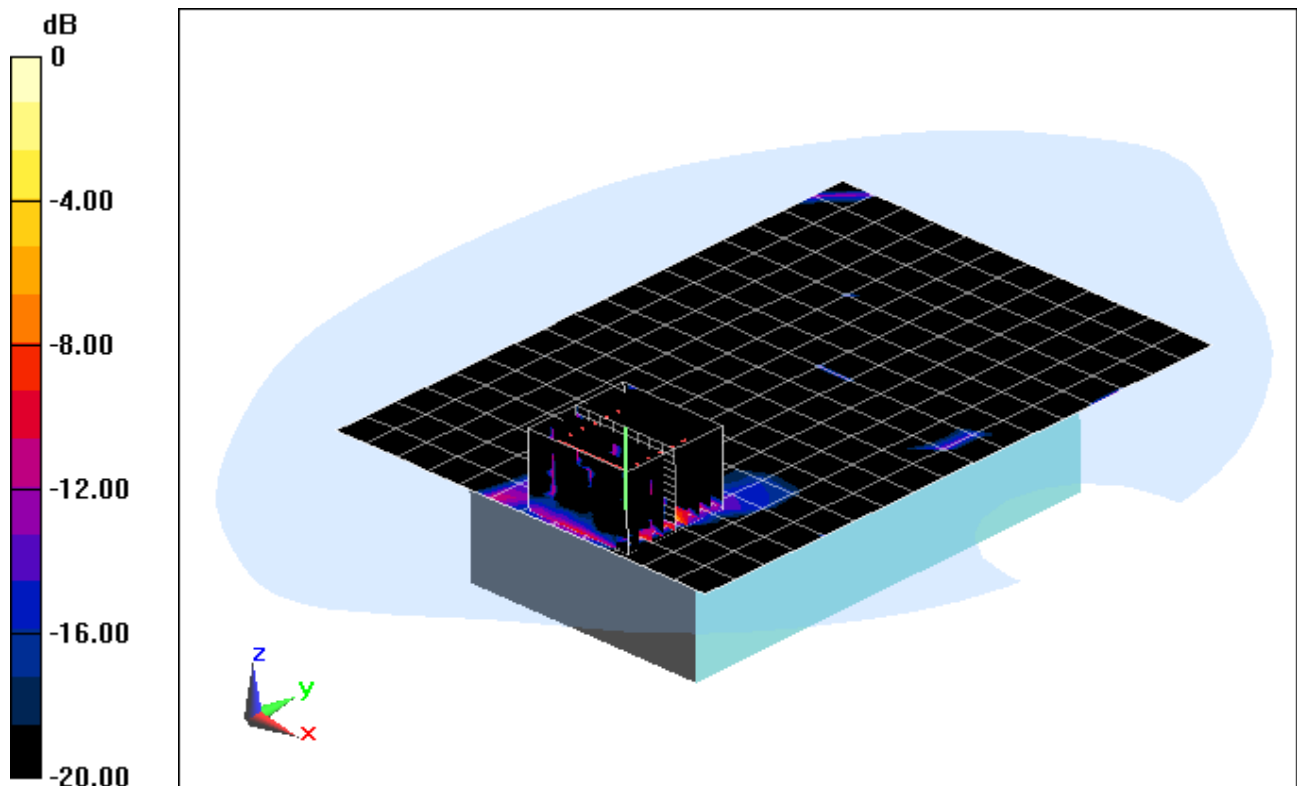

0 dB = 0.526 mW/g = -5.58 dB mW/g

PCTEST ENGINEERING LABORATORY, INC.

EUT: A3LEKGC100A; Type: Portable Camera; Serial: S3GC-0622

Communication System: IEEE 802.11a 5.2-5.8 GHz Band; Frequency: 5520 MHz; Duty Cycle: 1:1
Medium: 5GHz Body Medium parameters used:

$$f = 5520 \text{ MHz}; \sigma = 5.697 \text{ mho/m}; \epsilon_r = 47.3; \rho = 1000 \text{ kg/m}^3$$

Phantom section: Flat Section; Space: 0.0 cm

Test Date: 08-27-2012; Ambient Temp: 24.5°C; Tissue Temp: 23.4°C

Probe: EX3DV4 - SN3589; ConvF(3.4, 3.4, 3.4); Calibrated: 1/27/2012;

Sensor-Surface: 2mm (Mechanical Surface Detection)

Electronics: DAE4 Sn1323; Calibrated: 2/15/2012

Phantom: SAM Main; Type: SAM 4.0; Serial: TP-1114

Measurement SW: DASY4, Version 4.7 (80); SEMCAD X Version 14.6.5 (6469)

Mode: IEEE 802.11a, 5.5 GHz, Hand SAR, Ch 104, 6 Mbps, Front Side

Area Scan (13x18x1): Measurement grid: dx=10mm, dy=10mm

Zoom Scan (9x9x12)/Cube 0: Measurement grid: dx=4mm, dy=4mm, dz=2mm

Reference Value = 18.062 V/m; Power Drift = 0.05 dB

Peak SAR (extrapolated) = 8.891 mW/g

SAR(1 g) = 1.69 mW/g; SAR(10 g) = 0.384 mW/g

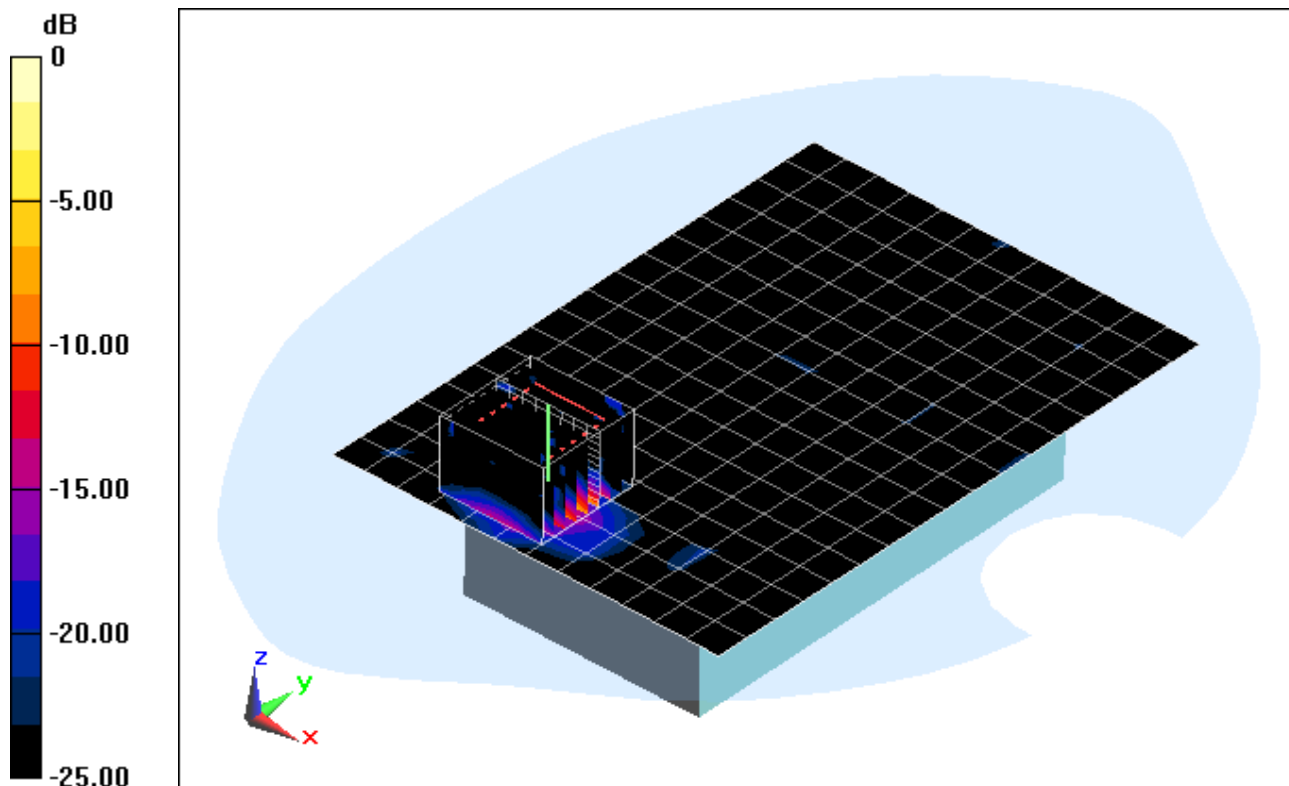

0 dB = 3.93 mW/g = 11.89 dB mW/g

PCTEST ENGINEERING LABORATORY, INC.

EUT: A3LEKGC100A; Type: Portable Camera; Serial: S3GC-0622

Communication System: IEEE 802.11a 5.2-5.8 GHz Band; Frequency: 5785 MHz; Duty Cycle: 1:1
Medium: 5GHz Body Medium parameters used:

$$f = 5785 \text{ MHz}; \sigma = 6.123 \text{ mho/m}; \epsilon_r = 46.74; \rho = 1000 \text{ kg/m}^3$$

Phantom section: Flat Section; Space: 0.0 cm

Test Date: 08-27-2012; Ambient Temp: 24.5°C; Tissue Temp: 23.6°C

Probe: EX3DV4 - SN3589; ConvF(3.59, 3.59, 3.59); Calibrated: 1/27/2012;

Sensor-Surface: 2mm (Mechanical Surface Detection)

Electronics: DAE4 Sn1323; Calibrated: 2/15/2012

Phantom: SAM Main; Type: SAM 4.0; Serial: TP-1114

Measurement SW: DASY4, Version 4.7 (80); SEMCAD X Version 14.6.5 (6469)

Mode: IEEE 802.11a, 5.8 GHz, Hand SAR, Ch 157, 6 Mbps, Top Side

Area Scan (9x18x1): Measurement grid: dx=10mm, dy=10mm

Zoom Scan (9x9x12)/Cube 0: Measurement grid: dx=4mm, dy=4mm, dz=2mm

Reference Value = 4.590 V/m; Power Drift = 0.12 dB

Peak SAR (extrapolated) = 0.881 mW/g

SAR(1 g) = 0.109 mW/g; SAR(10 g) = 0.023 mW/g

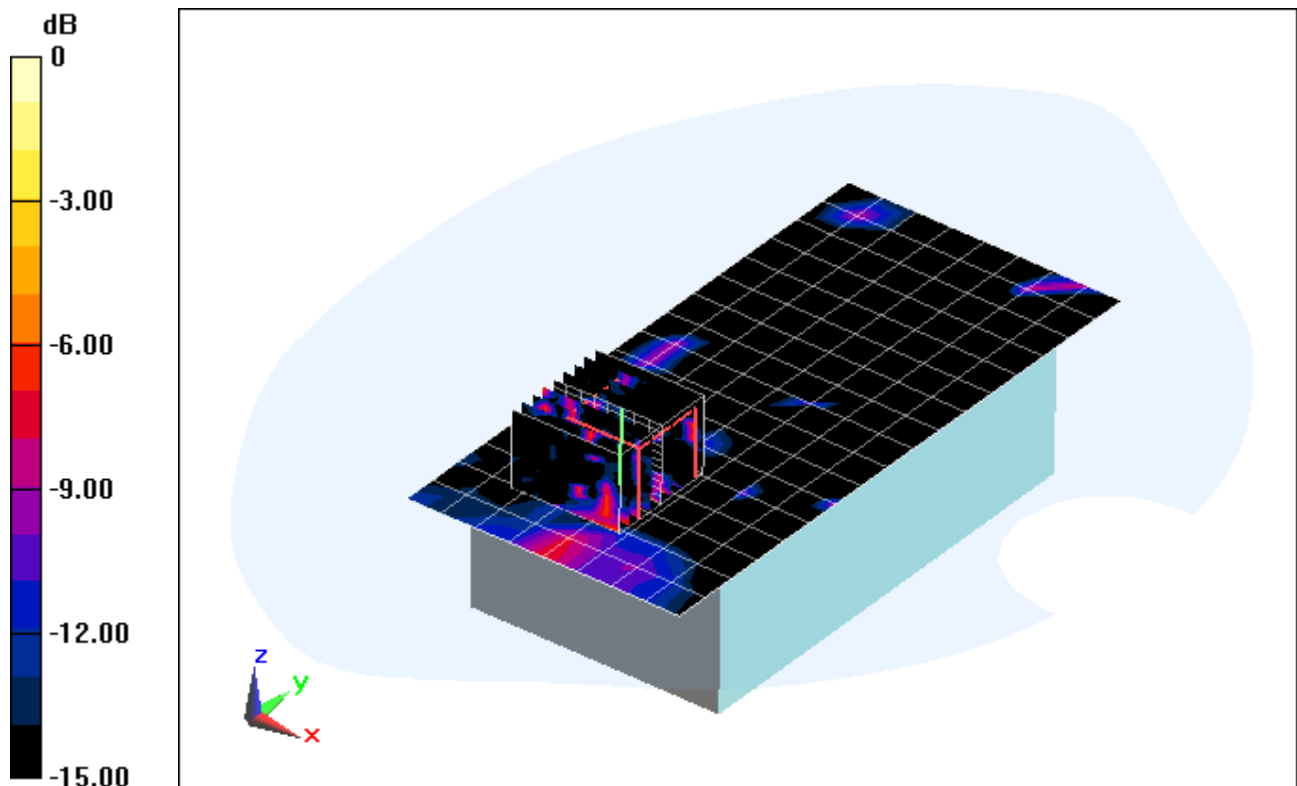

0 dB = 0.282 mW/g = -11.00 dB mW/g

PCTEST ENGINEERING LABORATORY, INC.

EUT: A3LEKGC100A; Type: Portable Camera; Serial: S3GC-0622

Communication System: IEEE 802.11a 5.2-5.8 GHz Band; Frequency: 5320 MHz; Duty Cycle: 1:1

Medium: 5GHz Body Medium parameters used:

$f = 5320 \text{ MHz}$; $\sigma = 5.347 \text{ mho/m}$; $\epsilon_r = 47.89$; $\rho = 1000 \text{ kg/m}^3$

Phantom section: Flat Section; Space: 0.0 cm

Test Date: 08-27-2012; Ambient Temp: 24.3°C; Tissue Temp: 23.4°C

Probe: EX3DV4 - SN3589; ConvF(3.72, 3.72, 3.72); Calibrated: 1/27/2012;

Sensor-Surface: 2mm (Mechanical Surface Detection)

Electronics: DAE4 Sn1323; Calibrated: 2/15/2012

Phantom: SAM Main; Type: SAM 4.0; Serial: TP-1114

Measurement SW: DASY4, Version 4.7 (80); SEMCAD X Version 14.6.5 (6469)

Mode: IEEE 802.11a, 5.3 GHz, Hand SAR, Ch 64, 6 Mbps, Left Side

Area Scan (9x13x1): Measurement grid: dx=10mm, dy=10mm

Zoom Scan (9x9x12)/Cube 0: Measurement grid: dx=4mm, dy=4mm, dz=2mm

Reference Value = 23.494 V/m; Power Drift = 0.04 dB

Peak SAR (extrapolated) = 11.952 mW/g

SAR(1 g) = 2.78 mW/g; SAR(10 g) = 0.649 mW/g

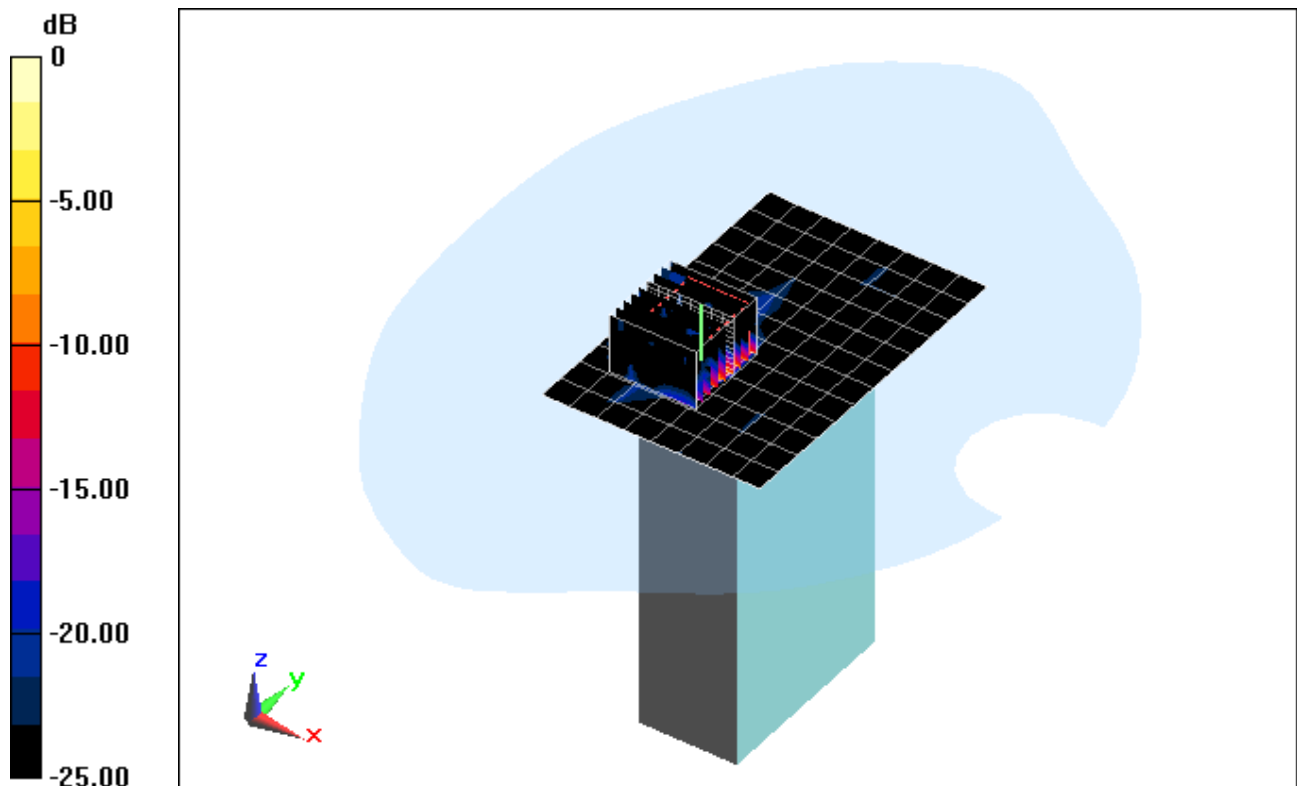

0 dB = 5.74 mW/g = 15.18 dB mW/g

PCTEST ENGINEERING LABORATORY, INC.

EUT: A3LEKGC100A; Type: Portable Camera; Serial: S3GC-0622

Communication System: IEEE 802.11a 5.2-5.8 GHz Band; Frequency: 5520 MHz; Duty Cycle: 1:1
Medium: 5GHz Body Medium parameters used:

$$f = 5520 \text{ MHz}; \sigma = 5.697 \text{ mho/m}; \epsilon_r = 47.3; \rho = 1000 \text{ kg/m}^3$$

Phantom section: Flat Section; Space: 1.0 cm

Test Date: 08-27-2012; Ambient Temp: 24.5°C; Tissue Temp: 23.4°C

Probe: EX3DV4 - SN3589; ConvF(3.4, 3.4, 3.4); Calibrated: 1/27/2012;

Sensor-Surface: 2mm (Mechanical Surface Detection)

Electronics: DAE4 Sn1323; Calibrated: 2/15/2012

Phantom: SAM Main; Type: SAM 4.0; Serial: TP-1114

Measurement SW: DASY4, Version 4.7 (80); SEMCAD X Version 14.6.5 (6469)

Mode: IEEE 802.11a, 5.5 GHz, Body SAR, Ch 104, 6 Mbps, Back Side

Area Scan (12x18x1): Measurement grid: dx=10mm, dy=10mm

Zoom Scan (7x7x12)/Cube 0: Measurement grid: dx=4mm, dy=4mm, dz=2mm

Reference Value = 3.328 V/m; Power Drift = -0.17 dB

Peak SAR (extrapolated) = 0.596 mW/g

SAR(1 g) = 0.066 mW/g; SAR(10 g) = 0.023 mW/g

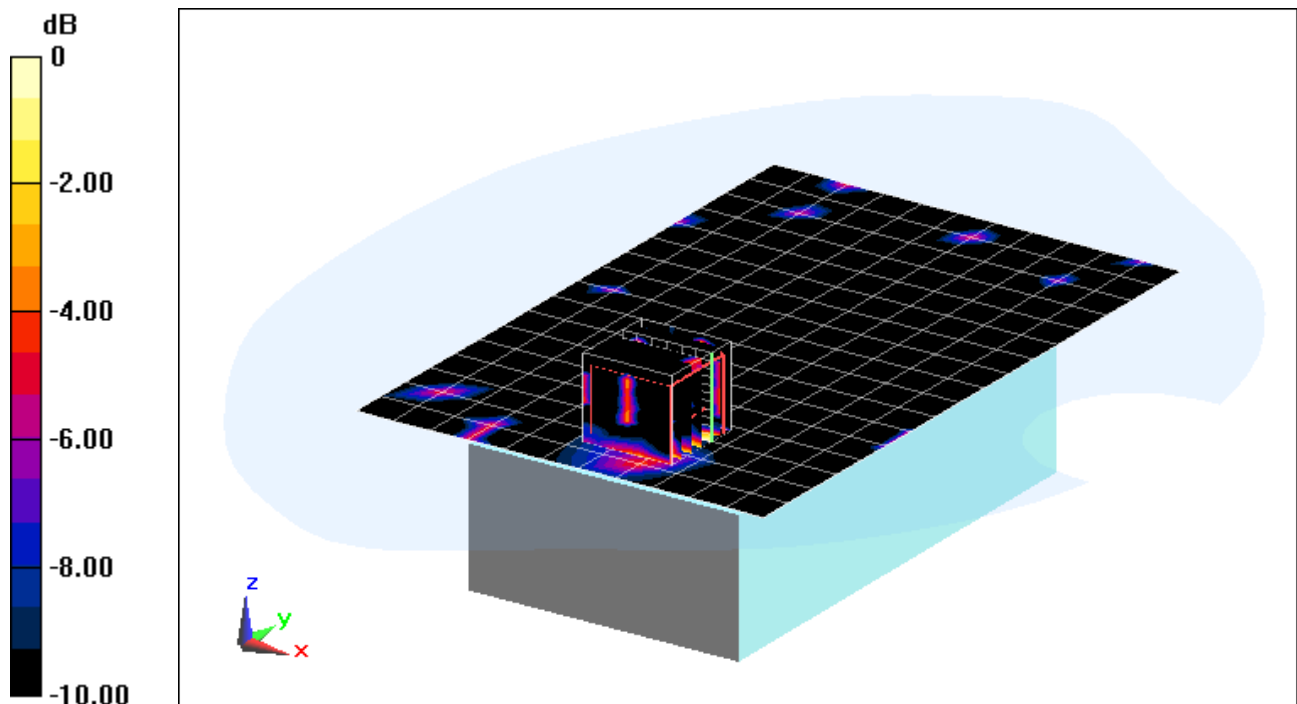

0 dB = 0.137 mW/g = -17.27 dB mW/g

PCTEST ENGINEERING LABORATORY, INC.

EUT: A3LEKGC100A; Type: Portable Camera; Serial: S3GC-0622

Communication System: IEEE 802.11a 5.2-5.8 GHz Band; Frequency: 5520 MHz; Duty Cycle: 1:1

Medium: 5GHz Body Medium parameters used:

$$f = 5520 \text{ MHz}; \sigma = 5.697 \text{ mho/m}; \epsilon_r = 47.3; \rho = 1000 \text{ kg/m}^3$$

Phantom section: Flat Section; Space: 1.0 cm

Test Date: 08-27-2012; Ambient Temp: 24.5°C; Tissue Temp: 23.4°C

Probe: EX3DV4 - SN3589; ConvF(3.4, 3.4, 3.4); Calibrated: 1/27/2012;

Sensor-Surface: 2mm (Mechanical Surface Detection)

Electronics: DAE4 Sn1323; Calibrated: 2/15/2012

Phantom: SAM Main; Type: SAM 4.0; Serial: TP-1114

Measurement SW: DASY4, Version 4.7 (80); SEMCAD X Version 14.6.5 (6469)

Mode: IEEE 802.11a, 5.5 GHz, Body SAR, Ch 104, 6 Mbps, Front Side

Area Scan (11x17x1): Measurement grid: dx=10mm, dy=10mm

Zoom Scan (7x7x12)/Cube 0: Measurement grid: dx=4mm, dy=4mm, dz=2mm

Reference Value = 7.145 V/m; Power Drift = 0.13 dB

Peak SAR (extrapolated) = 0.950 mW/g

SAR(1 g) = 0.260 mW/g; SAR(10 g) = 0.089 mW/g

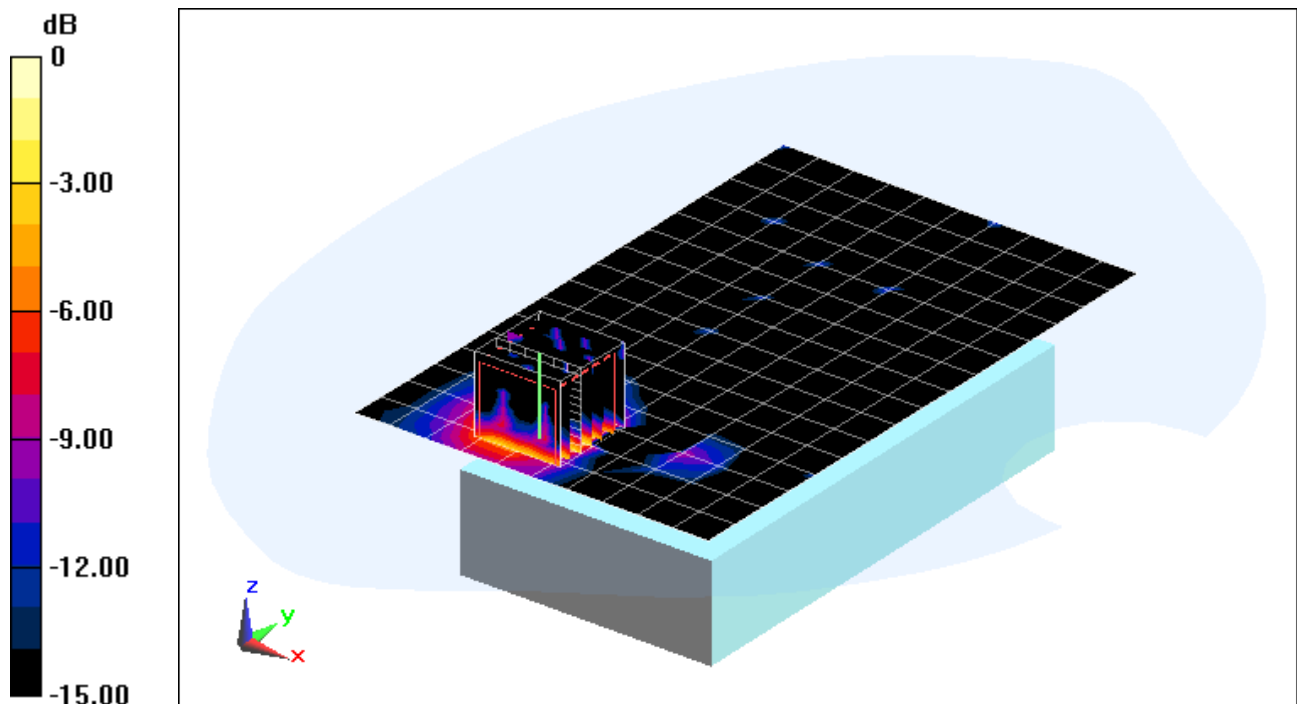

0 dB = 0.505 mW/g = -5.93 dB mW/g

PCTEST ENGINEERING LABORATORY, INC.

EUT: A3LEKGC100A; Type: Portable Camera; Serial: S3GC-0622

Communication System: IEEE 802.11a 5.2-5.8 GHz Band; Frequency: 5520 MHz; Duty Cycle: 1:1
Medium: 5GHz Body Medium parameters used:

$$f = 5520 \text{ MHz}; \sigma = 5.697 \text{ mho/m}; \epsilon_r = 47.3; \rho = 1000 \text{ kg/m}^3$$

Phantom section: Flat Section; Space: 1.0 cm

Test Date: 08-27-2012; Ambient Temp: 24.5°C; Tissue Temp: 23.4°C

Probe: EX3DV4 - SN3589; ConvF(3.4, 3.4, 3.4); Calibrated: 1/27/2012;

Sensor-Surface: 2mm (Mechanical Surface Detection)

Electronics: DAE4 Sn1323; Calibrated: 2/15/2012

Phantom: SAM Main; Type: SAM 4.0; Serial: TP-1114

Measurement SW: DASY4, Version 4.7 (80); SEMCAD X Version 14.6.5 (6469)

Mode: IEEE 802.11a, 5.5 GHz, Body SAR, Ch 104, 6 Mbps, Top Edge

Area Scan (9x18x1): Measurement grid: dx=10mm, dy=10mm

Zoom Scan (7x7x7)/Cube 0: Measurement grid: dx=5mm, dy=5mm, dz=5mm

Reference Value = 1.188 V/m; Power Drift = 0.04 dB

Peak SAR (extrapolated) = 0.045 mW/g

SAR(1 g) = 0.0035 mW/g; SAR(10 g) = 0.000525 mW/g

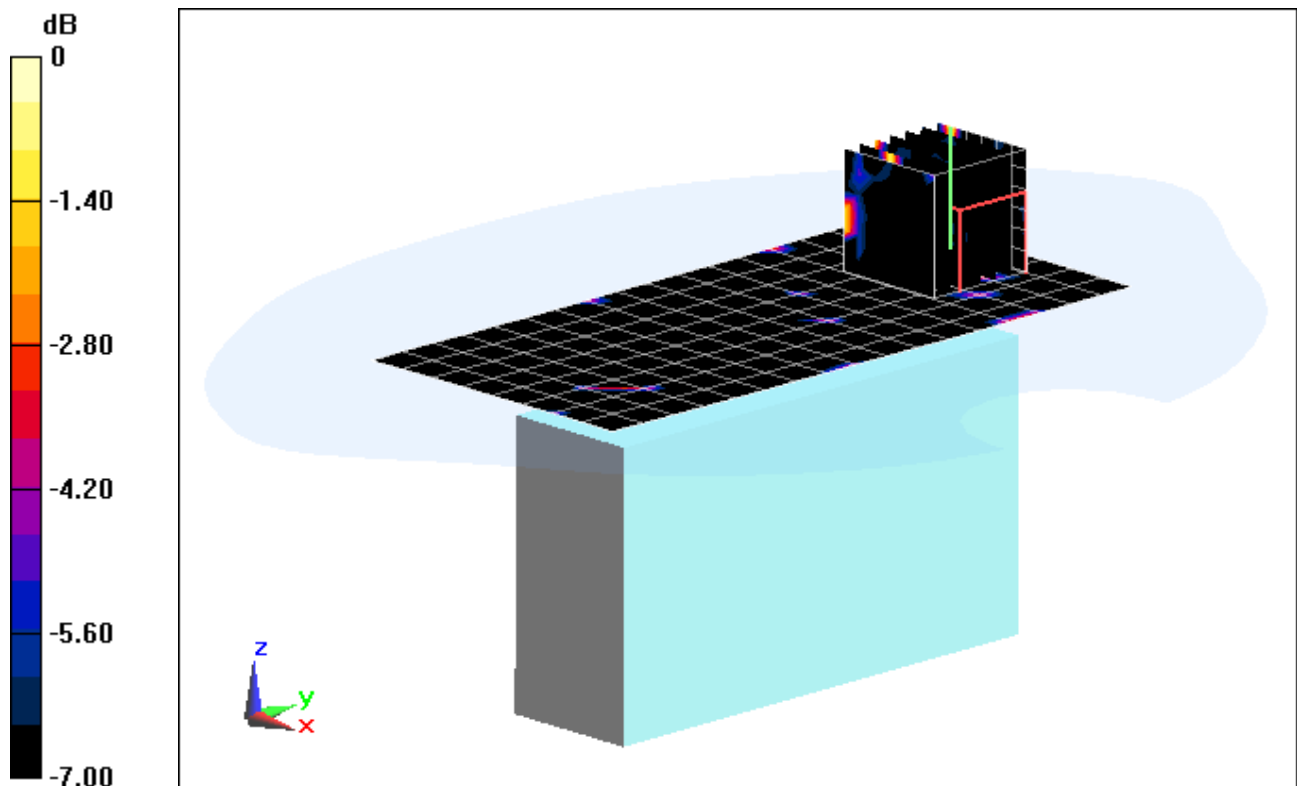

0 dB = 0.0672 mW/g = -23.45 dB mW/g

PCTEST ENGINEERING LABORATORY, INC.

EUT: A3LEKGC100A; Type: Portable Camera; Serial: S3GC-0622

Communication System: IEEE 802.11a 5.0 - 5.8 GHz Band; Frequency: 5520 MHz; Duty Cycle: 1:1

Medium: 5GHz Body Medium parameters used:

$f = 5520 \text{ MHz}$; $\sigma = 5.697 \text{ mho/m}$; $\epsilon_r = 47.3$; $\rho = 1000 \text{ kg/m}^3$

Phantom section: Flat Section; Space: 1.0 cm

Test Date: 08-27-2012; Ambient Temp: 24.5°C; Tissue Temp: 23.4°C

Probe: EX3DV4 - SN3589; ConvF(3.4, 3.4, 3.4); Calibrated: 1/27/2012;

Sensor-Surface: 2mm (Mechanical Surface Detection)

Electronics: DAE4 Sn1323; Calibrated: 2/15/2012

Phantom: SAM Main; Type: SAM 4.0; Serial: TP-1114

Measurement SW: DASY4, Version 4.7 (80); SEMCAD X Version 14.6.5 (6469)

Mode: IEEE 802.11a, 5.5 GHz, Body SAR, Ch 104, 6 Mbps, Left Side

Area Scan (9x13x1): Measurement grid: dx=10mm, dy=10mm

Zoom Scan (9x9x12)/Cube 0: Measurement grid: dx=4mm, dy=4mm, dz=2mm

Reference Value = 4.983 V/m; Power Drift = 0.15 dB

Peak SAR (extrapolated) = 1.436 mW/g

SAR(1 g) = 0.386 mW/g; SAR(10 g) = 0.131 mW/g

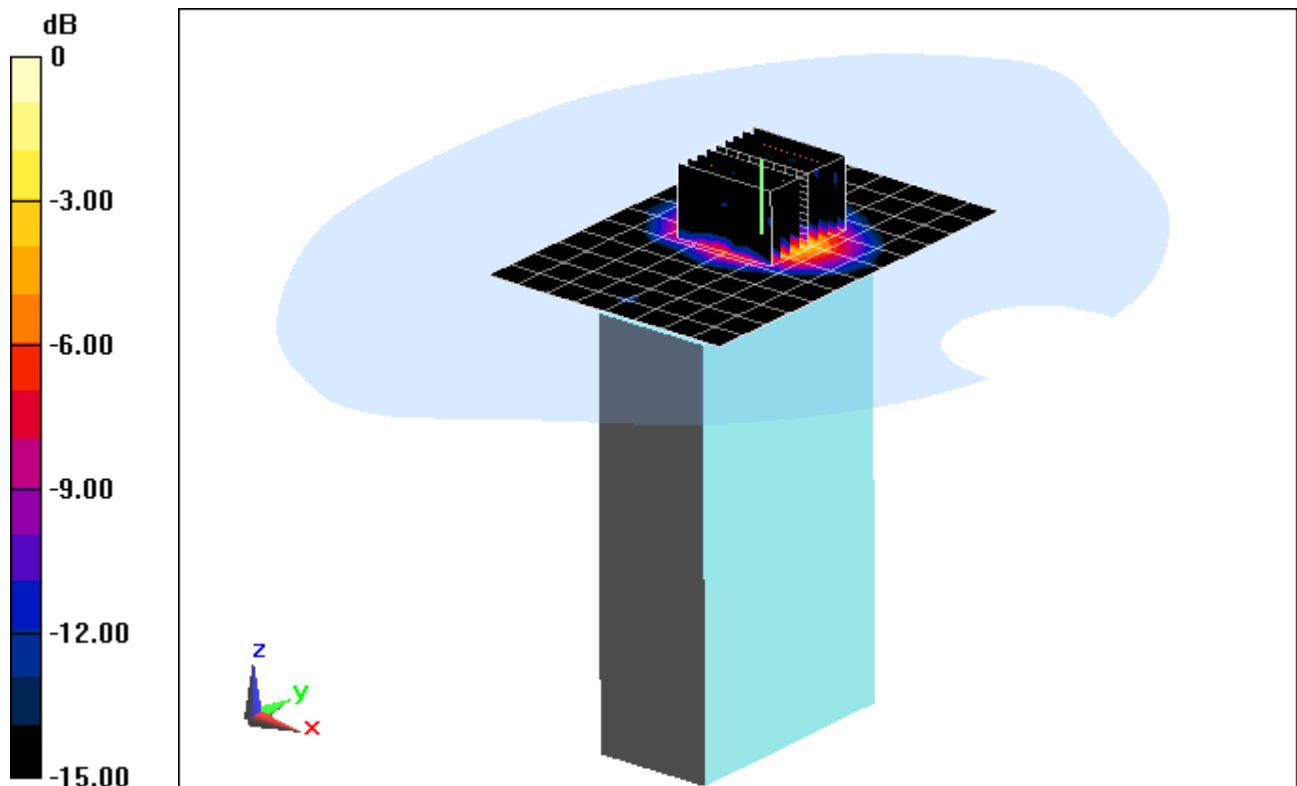

0 dB = 0.823 mW/g = -1.69 dB mW/g

APPENDIX B: SYSTEM VERIFICATION

PCTEST ENGINEERING LABORATORY, INC.

DUT: Dipole 835 MHz; Type: D835V2; Serial: 4d119

Communication System: CW; Frequency: 835 MHz; Duty Cycle: 1:1

Medium: 835 Body Medium parameters used:

$f = 835 \text{ MHz}$; $\sigma = 0.977 \text{ mho/m}$; $\epsilon_r = 54.03$; $\rho = 1000 \text{ kg/m}^3$

Phantom section: Flat Section; Space: 1.5 cm

Test Date: 10-05-2012; Ambient Temp: 23.8°C; Tissue Temp: 22.8°C

Probe: ES3DV2 - SN3022; ConvF(6.02, 6.02, 6.02); Calibrated: 8/28/2012;

Sensor-Surface: 4mm (Mechanical Surface Detection)

Electronics: DAE4 Sn1322; Calibrated: 8/24/2012

Phantom: SAM Main; Type: SAM 4.0; Serial: TP-1406

Measurement SW: DASY4, Version 4.7 (80); SEMCAD X Version 14.6.5 (6469)

835 MHz System Verification

Area Scan (7x13x1): Measurement grid: dx=15mm, dy=15mm

Zoom Scan (5x5x7)/Cube 0: Measurement grid: dx=8mm, dy=8mm, dz=5mm

Input Power = 20.0 dBm (100 mW)

Peak SAR (extrapolated) = 1.402 mW/g

SAR(1 g) = 0.964 mW/g; SAR(10 g) = 0.635 mW/g

Deviation = 0.84%

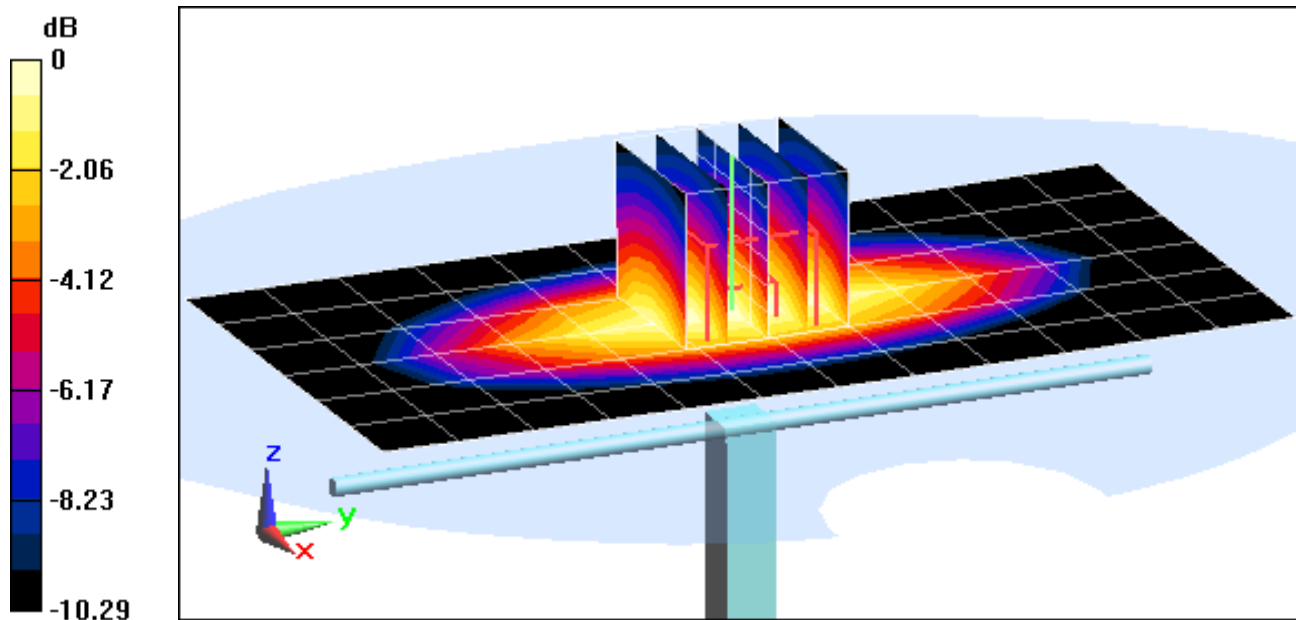

0 dB = 1.04 mW/g = 0.34 dB mW/g

PCTEST ENGINEERING LABORATORY, INC.

DUT: Dipole 835 MHz; Type: D835V2; Serial: 4d119

Communication System: CW; Frequency: 835 MHz; Duty Cycle: 1:1

Medium: 835 Body Medium parameters used:

$f = 835 \text{ MHz}$; $\sigma = 0.977 \text{ mho/m}$; $\epsilon_r = 54.03$; $\rho = 1000 \text{ kg/m}^3$

Phantom section: Flat Section; Space: 1.5 cm

Test Date: 10-05-2012; Ambient Temp: 23.8°C; Tissue Temp: 22.8°C

Probe: ES3DV2 - SN3022; ConvF(6.02, 6.02, 6.02); Calibrated: 8/28/2012;

Sensor-Surface: 4mm (Mechanical Surface Detection)

Electronics: DAE4 Sn1322; Calibrated: 8/24/2012

Phantom: SAM Main; Type: SAM 4.0; Serial: TP-1406

Measurement SW: DASY4, Version 4.7 (80); SEMCAD X Version 14.6.5 (6469)

835 MHz System Verification

Area Scan (7x13x1): Measurement grid: dx=15mm, dy=15mm

Zoom Scan (5x5x7)/Cube 0: Measurement grid: dx=8mm, dy=8mm, dz=5mm

Input Power = 20.0 dBm (100 mW)

Peak SAR (extrapolated) = 1.402 mW/g

SAR(1 g) = 0.964 mW/g; SAR(10 g) = 0.635 mW/g

Deviation = 0.84%

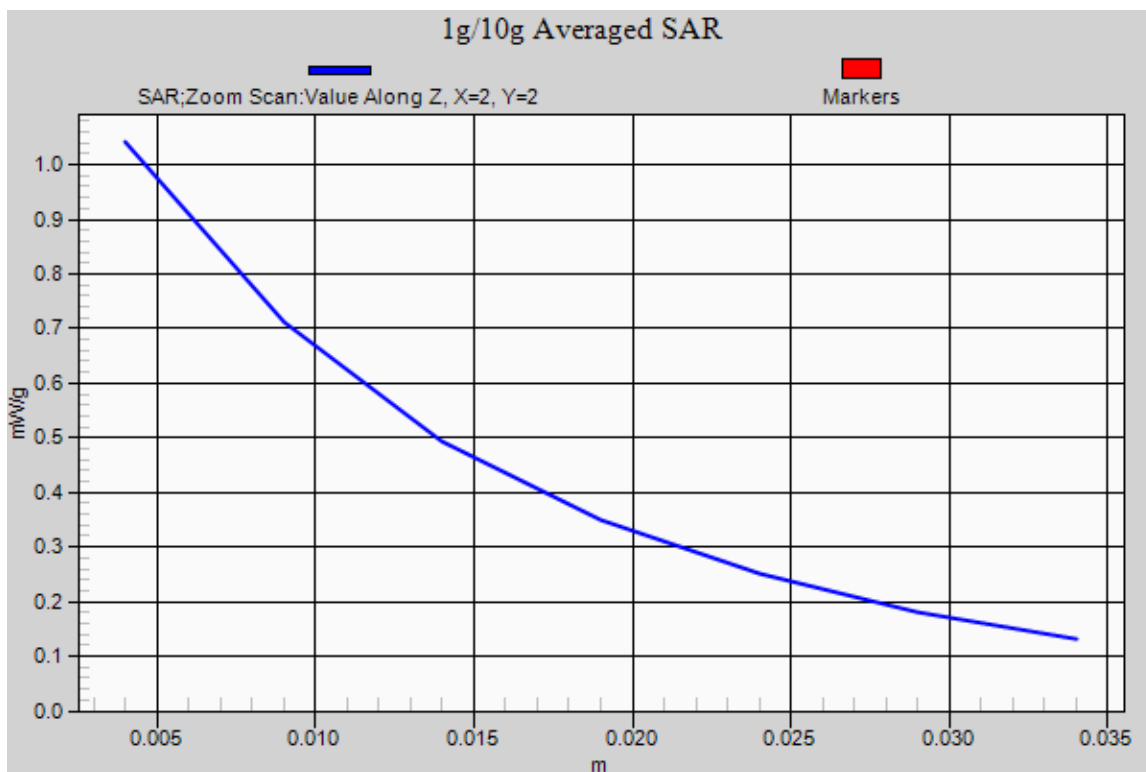

PCTEST ENGINEERING LABORATORY, INC.

DUT: SAR Dipole 1900 MHz; Type: D1900V2; Serial: 5d149

Communication System: CW; Frequency: 1900 MHz; Duty Cycle: 1:1

Medium: 1900 Body; Medium parameters used (interpolated):

$f = 1900 \text{ MHz}$; $\sigma = 1.577 \text{ mho/m}$; $\epsilon_r = 51.82$; $\rho = 1000 \text{ kg/m}^3$

Phantom section: Flat Section; Space: 1.0 cm

Test Date: 10-04-2012; Ambient Temp: 24.1°C; Tissue Temp: 23.0°C

Probe: ES3DV3 - SN3213; ConvF(4.5, 4.5, 4.5); Calibrated: 4/24/2012;

Sensor-Surface: 4mm (Mechanical Surface Detection)

Electronics: DAE4 Sn1334; Calibrated: 5/7/2012

Phantom: ELI v5.0 Door; Type: QDOVA002BB; Serial: TP-1158

Measurement SW: DASY52, Version 52.8 (1);SEMCAD X Version 14.6.5 (6469)

1900 MHz System Verification

Area Scan (7x9x1): Measurement grid: $dx=15\text{mm}$, $dy=15\text{mm}$

Zoom Scan (5x5x7)/Cube 0: Measurement grid: $dx=8\text{mm}$, $dy=8\text{mm}$, $dz=5\text{mm}$

Input Power = 20.0 dBm (100 mW)

Peak SAR (extrapolated) = 7.112 mW/g

SAR(1 g) = 3.92 mW/g; SAR(10 g) = 2.05 mW/g

Deviation = -0.25%

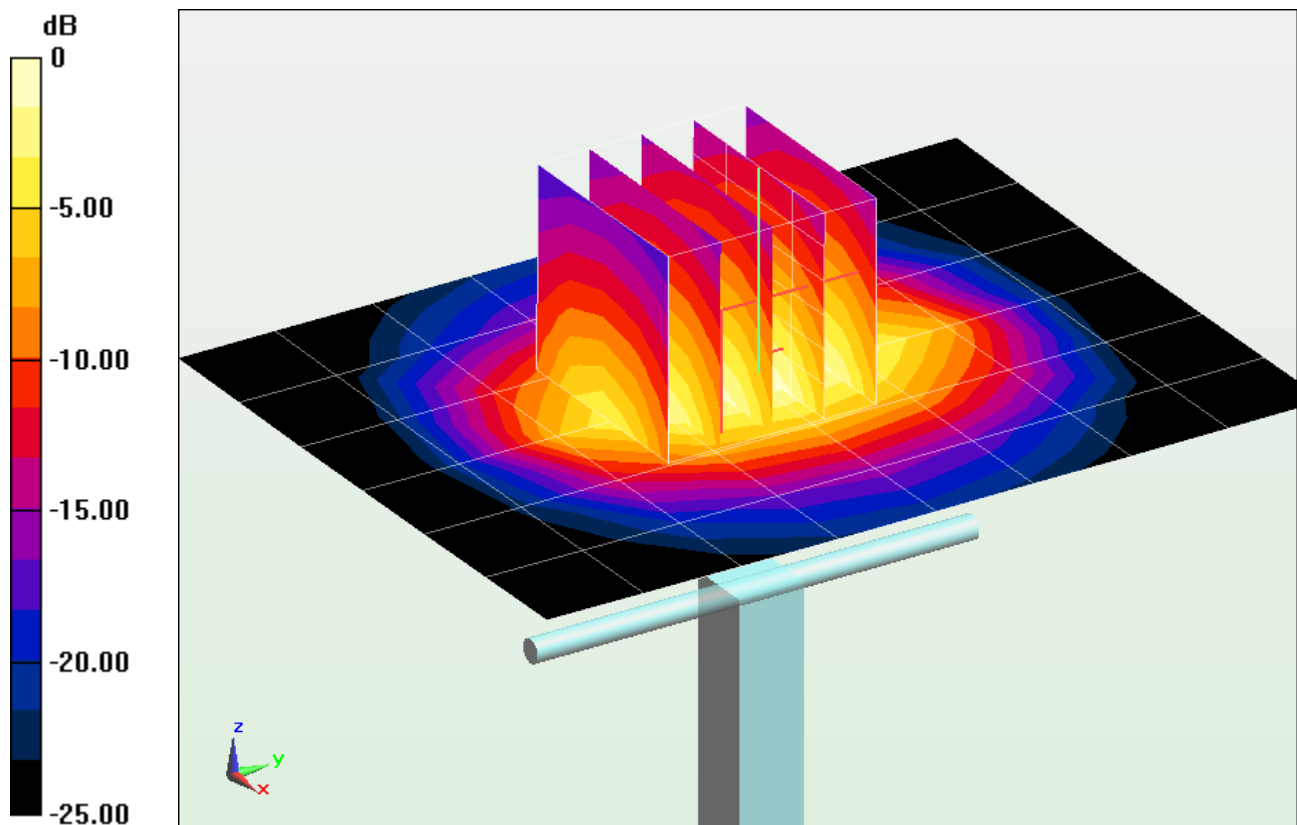

0 dB = 4.34 mW/g = 12.75 dB mW/g

PCTEST ENGINEERING LABORATORY, INC.

DUT: SAR Dipole 1900 MHz; Type: D1900V2; Serial: 5d149

Communication System: CW; Frequency: 1900 MHz; Duty Cycle: 1:1

Medium: 1900 Body; Medium parameters used (interpolated):

$f = 1900 \text{ MHz}$; $\sigma = 1.577 \text{ mho/m}$; $\epsilon_r = 51.82$; $\rho = 1000 \text{ kg/m}^3$

Phantom section: Flat Section; Space: 1.0 cm

Test Date: 10-04-2012; Ambient Temp: 24.1°C; Tissue Temp: 23.0°C

Probe: ES3DV3 - SN3213; ConvF(4.5, 4.5, 4.5); Calibrated: 4/24/2012;

Sensor-Surface: 4mm (Mechanical Surface Detection)

Electronics: DAE4 Sn1334; Calibrated: 5/7/2012

Phantom: ELI v5.0 Door; Type: QDOVA002BB; Serial: TP-1158

Measurement SW: DASY52, Version 52.8 (1);SEMCAD X Version 14.6.5 (6469)

1900 MHz System Verification

Area Scan (7x9x1): Measurement grid: dx=15mm, dy=15mm

Zoom Scan (5x5x7)/Cube 0: Measurement grid: dx=8mm, dy=8mm, dz=5mm

Input Power = 20.0 dBm (100 mW)

Peak SAR (extrapolated) = 7.112 mW/g

SAR(1 g) = 3.92 mW/g; SAR(10 g) = 2.05 mW/g

Deviation = -0.25%

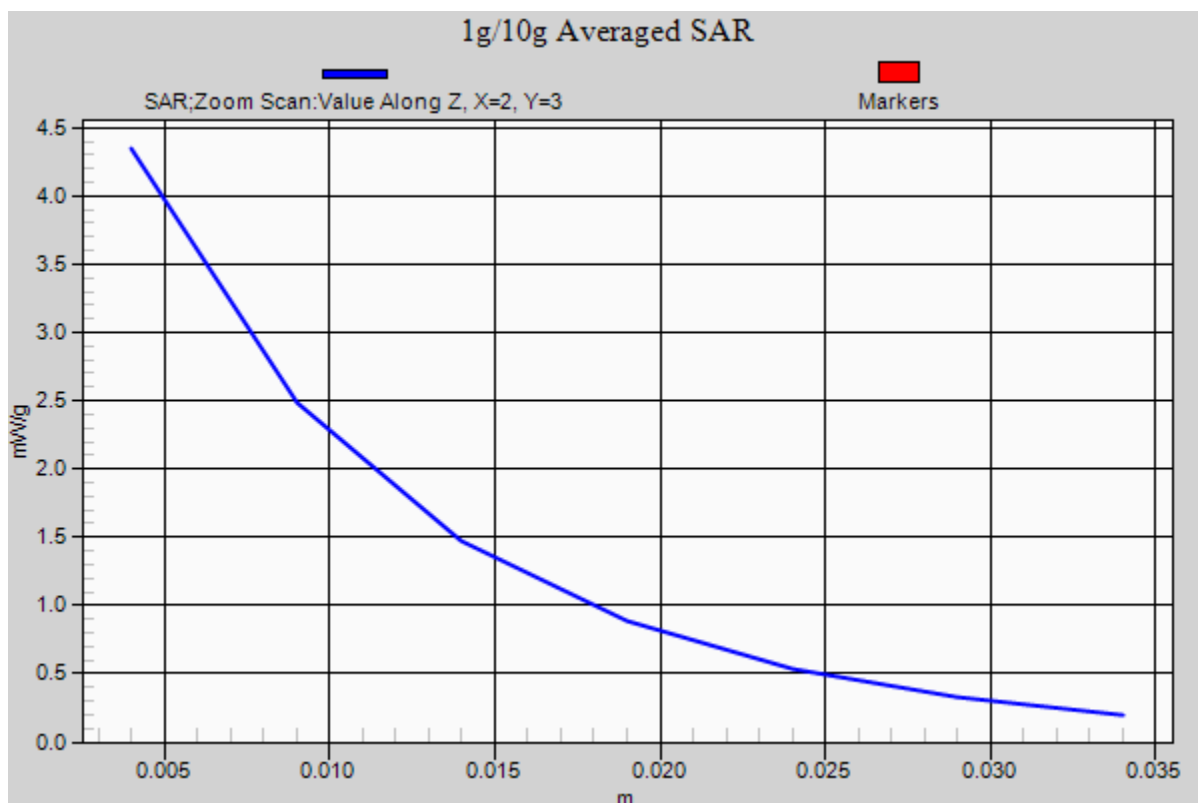

PCTEST ENGINEERING LABORATORY, INC.

DUT: SAR Dipole 1900 MHz; Type: D1900V2; Serial: 5d148

Communication System: CW; Frequency: 1900 MHz; Duty Cycle: 1:1

Medium: 1900 Body Medium parameters used (interpolated):

$f = 1900 \text{ MHz}$; $\sigma = 1.529 \text{ mho/m}$; $\epsilon_r = 52.507$; $\rho = 1000 \text{ kg/m}^3$

Phantom section: Flat Section; Space: 1.0 cm

Test Date: 10-11-2012; Ambient Temp: 23.4°C; Tissue Temp: 22.0°C

Probe: ES3DV3 - SN3213; ConvF(4.5, 4.5, 4.5); Calibrated: 4/24/2012;

Sensor-Surface: 4mm (Mechanical Surface Detection)

Electronics: DAE4 Sn1334; Calibrated: 5/7/2012

Phantom: ELI v5.0 Door; Type: QDOVA002BB; Serial: TP-1158

Measurement SW: DASY52, Version 52.8 (3);SEMCAD X Version 14.6.7 (6848)

1900 MHz System Verification

Area Scan (7x9x1): Measurement grid: dx=15mm, dy=15mm

Zoom Scan (5x5x7)/Cube 0: Measurement grid: dx=8mm, dy=8mm, dz=5mm

Input Power = 20.0 dBm (100 mW)

Peak SAR (extrapolated) = 6.99 W/kg

SAR(1 g) = 3.83 W/kg; SAR(10 g) = 2 W/kg

Deviation = -2.05%

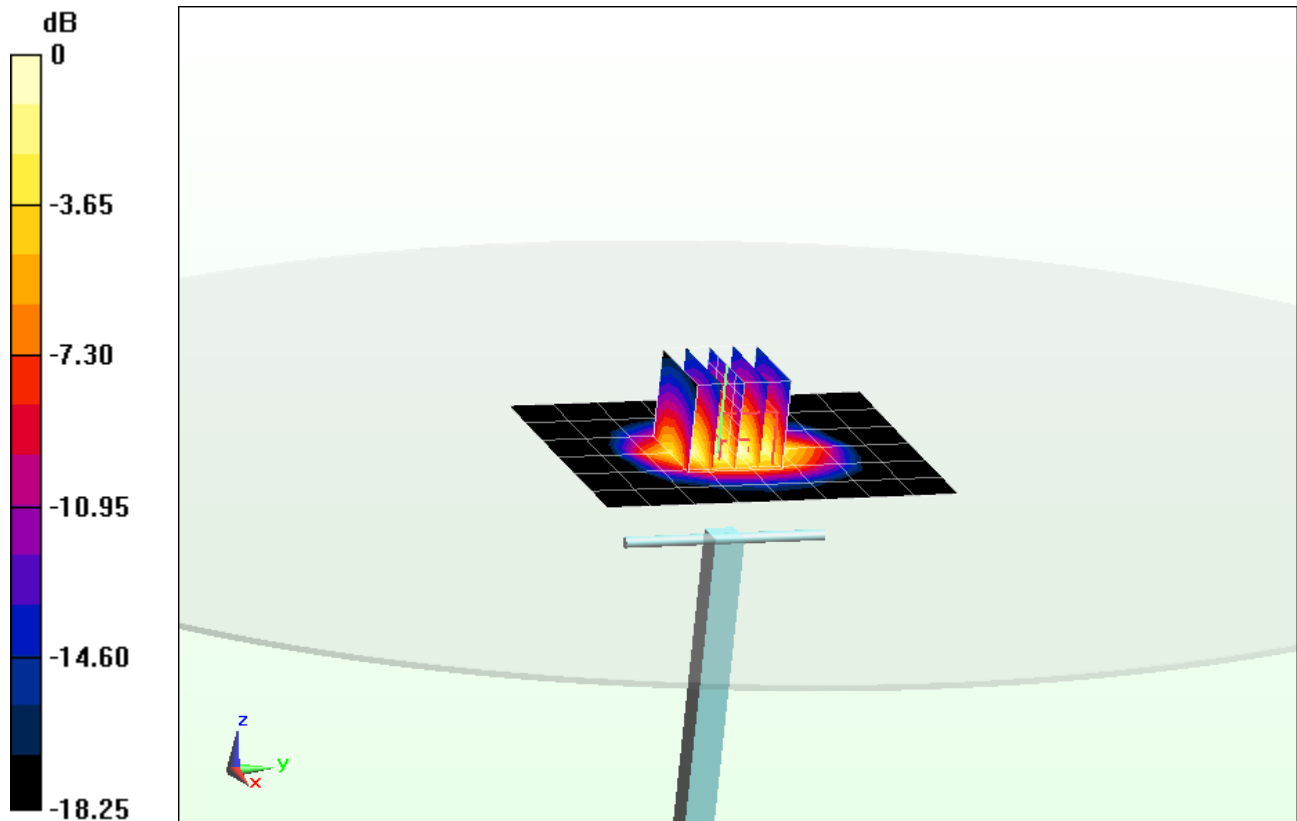

0 dB = 4.22 W/kg = 6.25 dBW/kg

PCTEST ENGINEERING LABORATORY, INC.

DUT: SAR Dipole 1900 MHz; Type: D1900V2; Serial: 5d148

Communication System: CW; Frequency: 1900 MHz; Duty Cycle: 1:1

Medium: 1900 Body Medium parameters used (interpolated):

$f = 1900 \text{ MHz}$; $\sigma = 1.529 \text{ mho/m}$; $\epsilon_r = 52.507$; $\rho = 1000 \text{ kg/m}^3$

Phantom section: Flat Section; Space: 1.0 cm

Test Date: 10-11-2012; Ambient Temp: 23.4°C; Tissue Temp: 22.0°C

Probe: ES3DV3 - SN3213; ConvF(4.5, 4.5, 4.5); Calibrated: 4/24/2012;

Sensor-Surface: 4mm (Mechanical Surface Detection)

Electronics: DAE4 Sn1334; Calibrated: 5/7/2012

Phantom: ELI v5.0 Door; Type: QDOVA002BB; Serial: TP-1158

Measurement SW: DASY52, Version 52.8 (3); SEMCAD X Version 14.6.7 (6848)

1900 MHz System Verification

Area Scan (7x9x1): Measurement grid: dx=15mm, dy=15mm

Zoom Scan (5x5x7)/Cube 0: Measurement grid: dx=8mm, dy=8mm, dz=5mm

Input Power = 20.0 dBm (100 mW)

Peak SAR (extrapolated) = 6.99 W/kg

SAR(1 g) = 3.83 W/kg; SAR(10 g) = 2 W/kg

Deviation = -2.05%

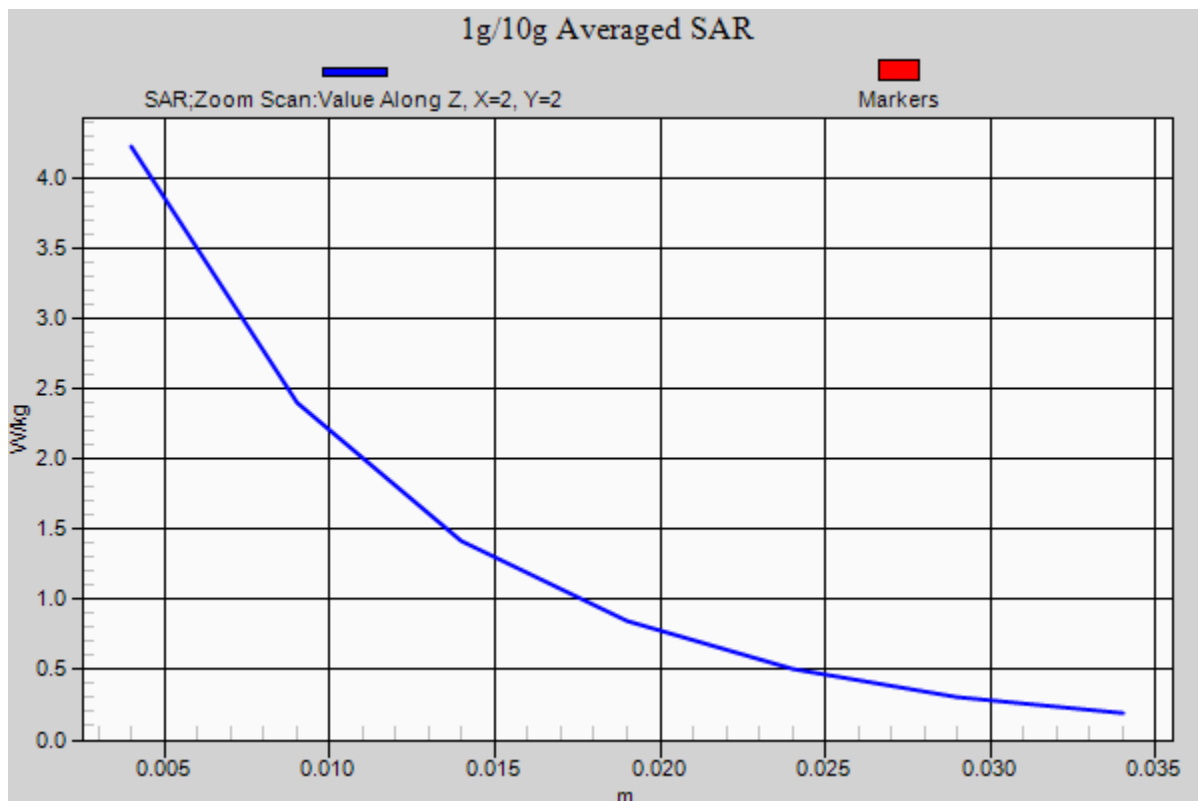

PCTEST ENGINEERING LABORATORY, INC.

DUT: SAR Dipole 2450 MHz; Type: D2450V2; Serial: 797

Communication System: CW; Frequency: 2450 MHz; Duty Cycle: 1:1

Medium: 2450 Body Medium parameters used:

$f = 2450$ MHz; $\sigma = 1.976$ mho/m; $\epsilon_r = 51.08$; $\rho = 1000$ kg/m³

Phantom section: Flat Section; Space: 1.0 cm

Test Date: 08-24-2012; Ambient Temp: 23.1°C; Tissue Temp: 22.9°C

Probe: EX3DV4 - SN3561; ConvF(6.22, 6.22, 6.22); Calibrated: 7/26/2012;

Sensor-Surface: 3mm (Mechanical Surface Detection)

Electronics: DAE4 Sn665; Calibrated: 4/19/2012

Phantom: SAM with CRP; Type: SAM; Serial: TP1375

Measurement SW: DASY4, Version 4.7 (80); SEMCAD X Version 14.6.5 (6469)

2450 MHz System Verification

Area Scan (6x8x1): Measurement grid: dx=12mm, dy=12mm

Zoom Scan (7x7x7)/Cube 0: Measurement grid: dx=5mm, dy=5mm, dz=5mm

Input Power: 10.0 dBm (10 mW)

Peak SAR (extrapolated) = 1.052 mW/g

SAR(1 g) = 0.522 mW/g; SAR(10 g) = 0.243 mW/g

Deviation = 2.76%

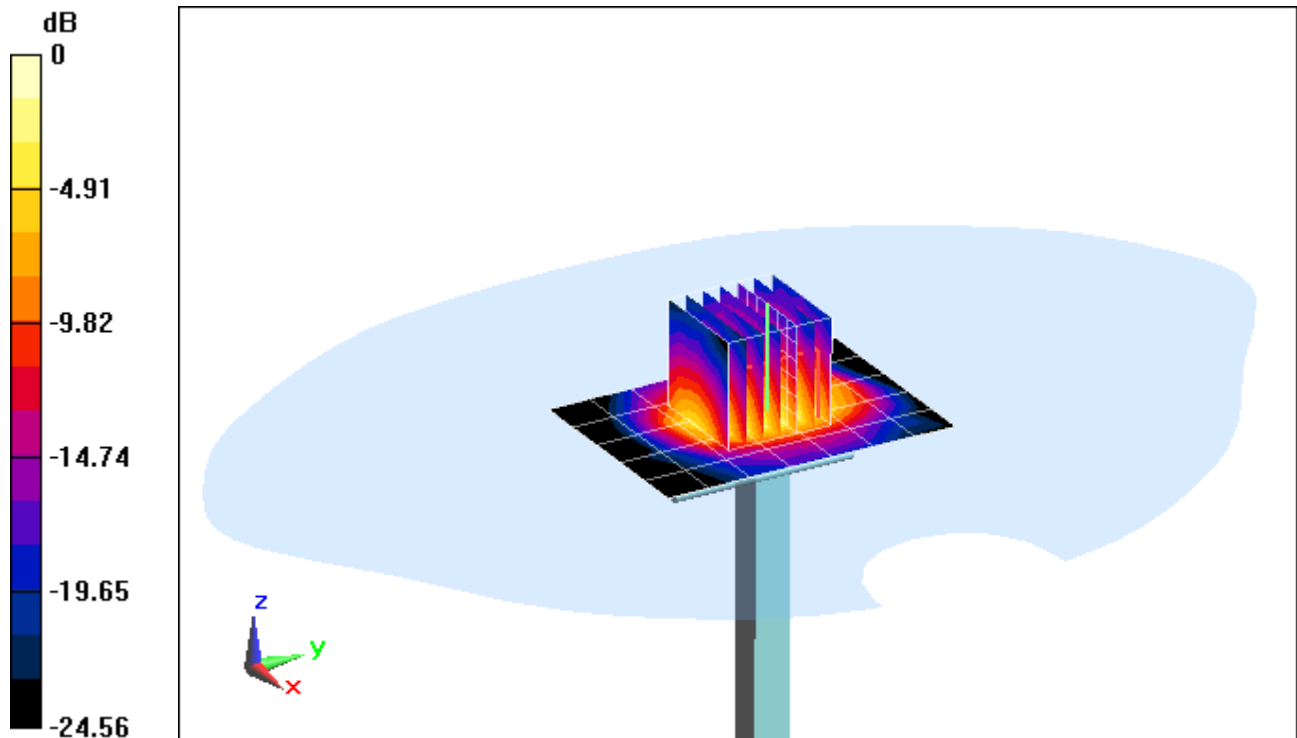

0 dB = 0.668 mW/g = -3.50 dB mW/g

PCTEST ENGINEERING LABORATORY, INC.

DUT: SAR Dipole 2450 MHz; Type: D2450V2; Serial: 797

Communication System: CW; Frequency: 2450 MHz; Duty Cycle: 1:1

Medium: 2450 Body Medium parameters used:

$f = 2450$ MHz; $\sigma = 1.976$ mho/m; $\epsilon_r = 51.08$; $\rho = 1000$ kg/m³

Phantom section: Flat Section; Space: 1.0 cm

Test Date: 08-24-2012; Ambient Temp: 23.1°C; Tissue Temp: 22.9°C

Probe: EX3DV4 - SN3561; ConvF(6.22, 6.22, 6.22); Calibrated: 7/26/2012;

Sensor-Surface: 3mm (Mechanical Surface Detection)

Electronics: DAE4 Sn665; Calibrated: 4/19/2012

Phantom: SAM with CRP; Type: SAM; Serial: TP1375

Measurement SW: DASY4, Version 4.7 (80); SEMCAD X Version 14.6.5 (6469)

2450 MHz System Verification

Area Scan (6x8x1): Measurement grid: dx=12mm, dy=12mm

Zoom Scan (7x7x7)/Cube 0: Measurement grid: dx=5mm, dy=5mm, dz=5mm

Input Power: 10.0 dBm (10 mW)

Peak SAR (extrapolated) = 1.052 mW/g

SAR(1 g) = 0.522 mW/g; SAR(10 g) = 0.243 mW/g

Deviation = 2.76%

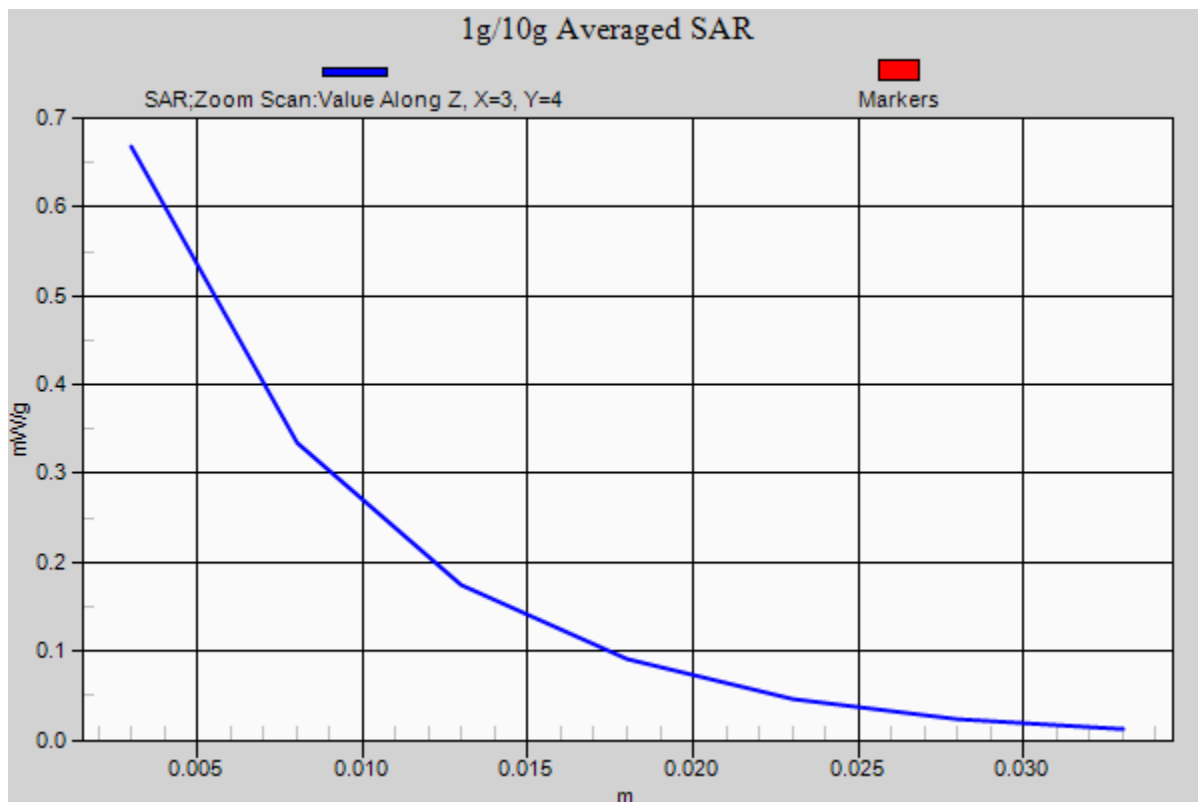

PCTEST ENGINEERING LABORATORY, INC.

DUT: Dipole 5200 MHz; Type: D5GHzV2; Serial: 1057

Communication System: CW; Frequency: 5200 MHz; Duty Cycle: 1:1

Medium: 5GHz Body Medium parameters used:

$f = 5200 \text{ MHz}$; $\sigma = 5.092 \text{ mho/m}$; $\epsilon_r = 48.32$; $\rho = 1000 \text{ kg/m}^3$

Phantom section: Flat Section; Space: 1.0 cm

Test Date: 08-27-2012; Ambient Temp: 24.3°C; Tissue Temp: 23.4°C

Probe: EX3DV4 - SN3589; ConvF(3.92, 3.92, 3.92); Calibrated: 1/27/2012;

Sensor-Surface: 2mm (Mechanical Surface Detection)

Electronics: DAE4 Sn1323; Calibrated: 2/15/2012

Phantom: SAM Main; Type: SAM 4.0; Serial: TP-1114

Measurement SW: DASY4, Version 4.7 (80); SEMCAD X Version 14.6.5 (6469)

5200 MHz System Verification

Area Scan (7x9x1): Measurement grid: dx=10mm, dy=10mm

Zoom Scan (7x7x12)/Cube 0: Measurement grid: dx=4mm, dy=4mm, dz=2mm

Input Power: 20.0 dBm (100 mW)

Peak SAR (extrapolated) = 29.875 mW/g

SAR(1 g) = 7.09 mW/g; SAR(10 g) = 1.94 mW/g

Deviation = -3.41%

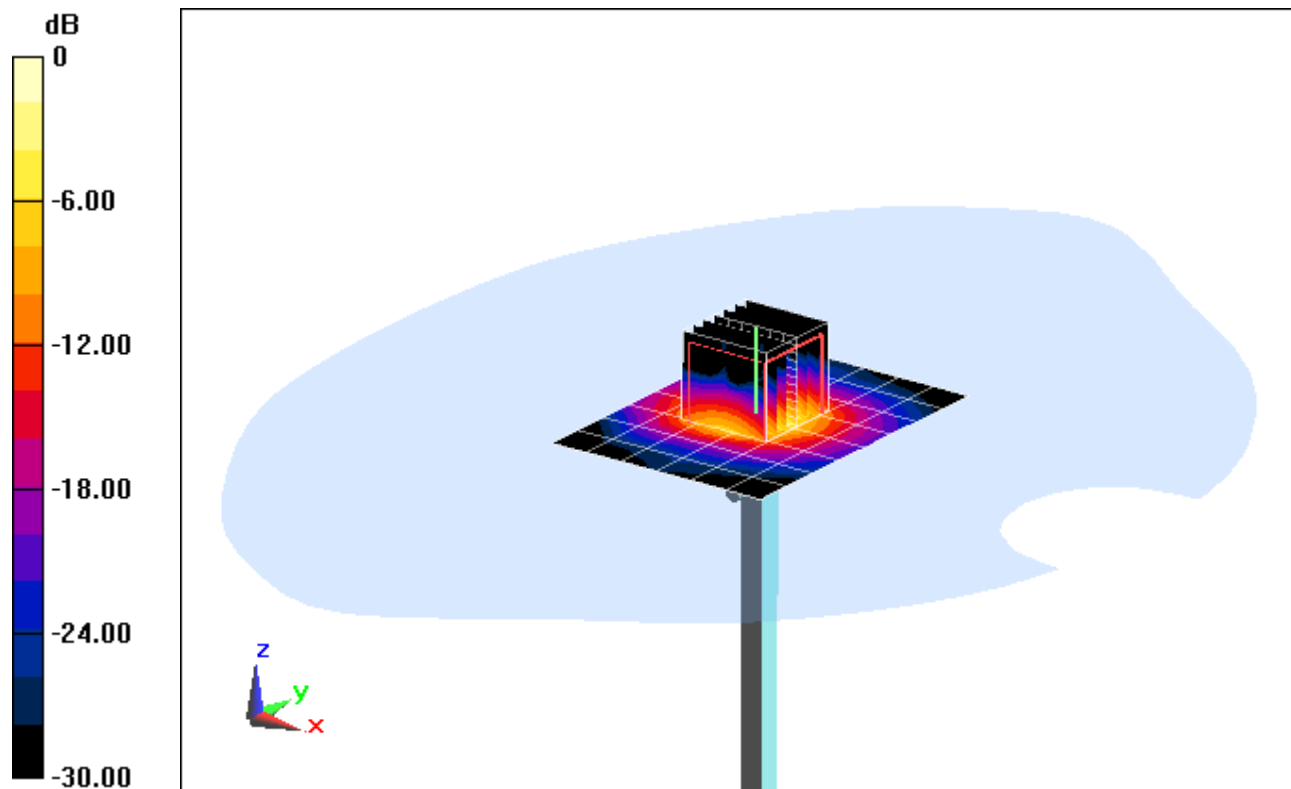

0 dB = 14.5 mW/g = 23.23 dB mW/g

PCTEST ENGINEERING LABORATORY, INC.

DUT: Dipole 5200 MHz; Type: D5GHzV2; Serial: 1057

Communication System: CW; Frequency: 5200 MHz; Duty Cycle: 1:1

Medium: 5GHz Body Medium parameters used:

$f = 5200 \text{ MHz}$; $\sigma = 5.092 \text{ mho/m}$; $\epsilon_r = 48.32$; $\rho = 1000 \text{ kg/m}^3$

Phantom section: Flat Section; Space: 1.0 cm

Test Date: 08-27-2012; Ambient Temp: 24.3°C; Tissue Temp: 23.4°C

Probe: EX3DV4 - SN3589; ConvF(3.92, 3.92, 3.92); Calibrated: 1/27/2012;

Sensor-Surface: 2mm (Mechanical Surface Detection)

Electronics: DAE4 Sn1323; Calibrated: 2/15/2012

Phantom: SAM Main; Type: SAM 4.0; Serial: TP-1114

Measurement SW: DASY4, Version 4.7 (80); SEMCAD X Version 14.6.5 (6469)

5200 MHz System Verification

Area Scan (7x9x1): Measurement grid: dx=10mm, dy=10mm

Zoom Scan (7x7x12)/Cube 0: Measurement grid: dx=4mm, dy=4mm, dz=2mm

Input Power: 20.0 dBm (100 mW)

Peak SAR (extrapolated) = 29.875 mW/g

SAR(1 g) = 7.09 mW/g; SAR(10 g) = 1.94 mW/g

Deviation = -3.41%

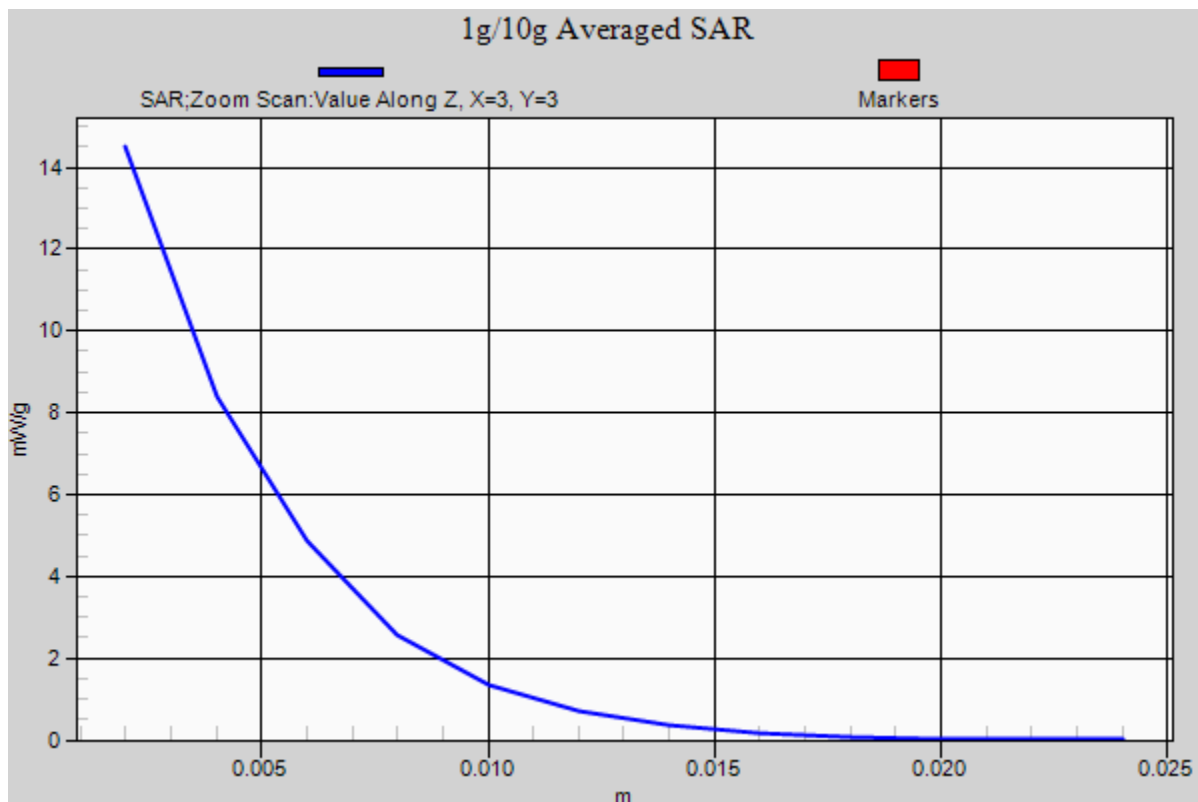

PCTEST ENGINEERING LABORATORY, INC.

DUT: Dipole 5500 MHz; Type: D5GHzV2; Serial: 1057

Communication System: CW; Frequency: 5500 MHz; Duty Cycle: 1:1

Medium: 5GHz Body Medium parameters used:

$f = 5500 \text{ MHz}$; $\sigma = 5.563 \text{ mho/m}$; $\epsilon_r = 47.39$; $\rho = 1000 \text{ kg/m}^3$

Phantom section: Flat Section; Space: 1.0 cm

Test Date: 08-27-2012; Ambient Temp: 24.5°C; Tissue Temp: 23.4°C

Probe: EX3DV4 - SN3589; ConvF(3.4, 3.4, 3.4); Calibrated: 1/27/2012;

Sensor-Surface: 2mm (Mechanical Surface Detection)

Electronics: DAE4 Sn1323; Calibrated: 2/15/2012

Phantom: SAM Main; Type: SAM 4.0; Serial: TP-1114

Measurement SW: DASY4, Version 4.7 (80); SEMCAD X Version 14.6.5 (6469)

5500 MHz System Verification

Area Scan (7x9x1): Measurement grid: dx=10mm, dy=10mm

Zoom Scan (7x7x12)/Cube 0: Measurement grid: dx=4mm, dy=4mm, dz=2mm

Input Power: 20.0 dBm (100 mW)

Peak SAR (extrapolated) = 36.184 mW/g

SAR(1 g) = 8.19 mW/g; SAR(10 g) = 2.13 mW/g

Deviation = 3.80%

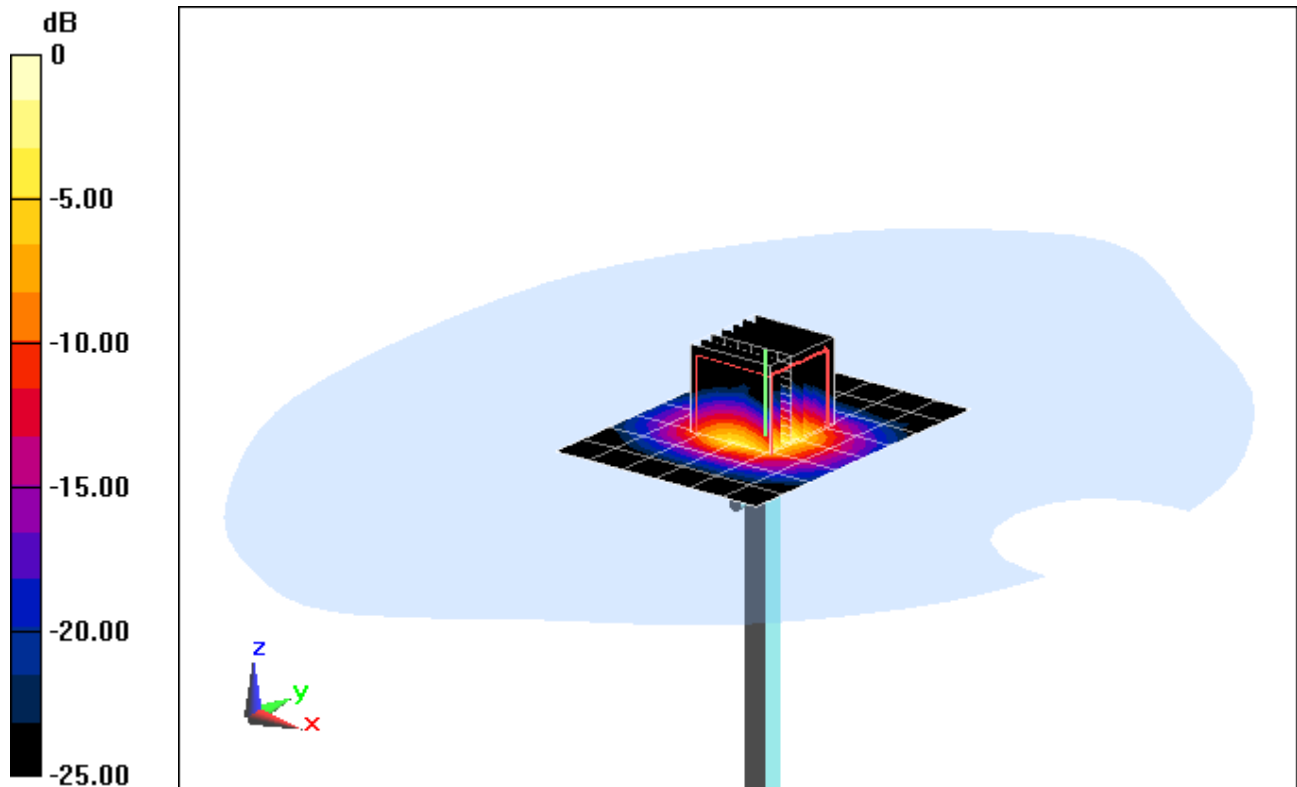

0 dB = 17.7 mW/g = 24.96 dB mW/g

PCTEST ENGINEERING LABORATORY, INC.

DUT: Dipole 5500 MHz; Type: D5GHzV2; Serial: 1057

Communication System: CW; Frequency: 5500 MHz; Duty Cycle: 1:1

Medium: 5GHz Body Medium parameters used:

$f = 5500 \text{ MHz}$; $\sigma = 5.563 \text{ mho/m}$; $\epsilon_r = 47.39$; $\rho = 1000 \text{ kg/m}^3$

Phantom section: Flat Section; Space: 1.0 cm

Test Date: 08-27-2012; Ambient Temp: 24.5°C; Tissue Temp: 23.4°C

Probe: EX3DV4 - SN3589; ConvF(3.4, 3.4, 3.4); Calibrated: 1/27/2012;

Sensor-Surface: 2mm (Mechanical Surface Detection)

Electronics: DAE4 Sn1323; Calibrated: 2/15/2012

Phantom: SAM Main; Type: SAM 4.0; Serial: TP-1114

Measurement SW: DASY4, Version 4.7 (80); SEMCAD X Version 14.6.5 (6469)

5500 MHz System Verification

Area Scan (7x9x1): Measurement grid: dx=10mm, dy=10mm

Zoom Scan (7x7x12)/Cube 0: Measurement grid: dx=4mm, dy=4mm, dz=2mm

Input Power: 20.0 dBm (100 mW)

Peak SAR (extrapolated) = 36.184 mW/g

SAR(1 g) = 8.19 mW/g; SAR(10 g) = 2.13 mW/g

Deviation = 3.80%

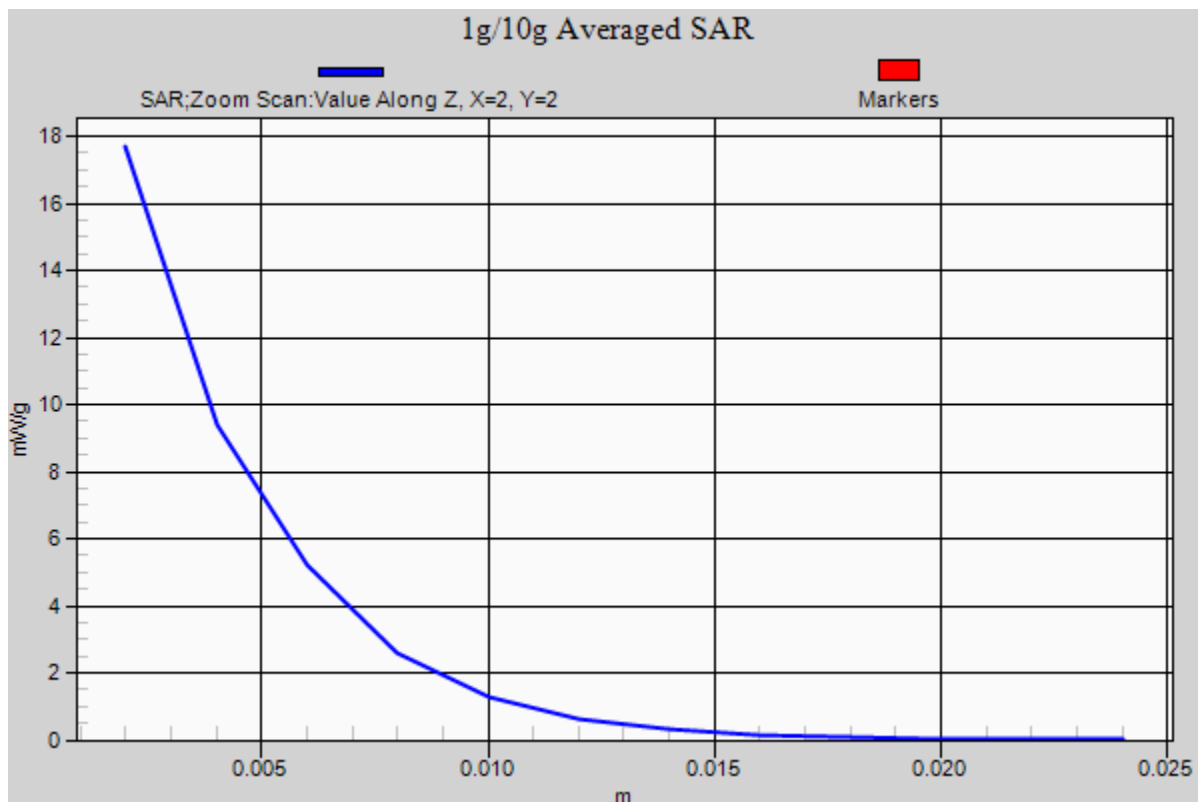

PCTEST ENGINEERING LABORATORY, INC.

DUT: Dipole 5800 MHz; Type: D5GHzV2; Serial: 1057

Communication System: CW; Frequency: 5800 MHz; Duty Cycle: 1:1

Medium: 5GHz Body Medium parameters used:

$f = 5800 \text{ MHz}$; $\sigma = 6.191 \text{ mho/m}$; $\epsilon_r = 46.66$; $\rho = 1000 \text{ kg/m}^3$

Phantom section: Flat Section; Space: 1.0 cm

Test Date: 08-27-2012; Ambient Temp: 24.5°C; Tissue Temp: 23.6°C

Probe: EX3DV4 - SN3589; ConvF(3.59, 3.59, 3.59); Calibrated: 1/27/2012;

Sensor-Surface: 2mm (Mechanical Surface Detection)

Electronics: DAE4 Sn1323; Calibrated: 2/15/2012

Phantom: SAM Main; Type: SAM 4.0; Serial: TP-1114

Measurement SW: DASY4, Version 4.7 (80); SEMCAD X Version 14.6.5 (6469)

5800 MHz System Verification

Area Scan (7x9x1): Measurement grid: dx=10mm, dy=10mm

Zoom Scan (7x7x11)/Cube 0: Measurement grid: dx=4mm, dy=4mm, dz=2mm

Input Power: 20.0 dBm (100 mW)

Peak SAR (extrapolated) = 32.035 mW/g

SAR(1 g) = 7.08 mW/g; SAR(10 g) = 1.91 mW/g

Deviation = -4.71%

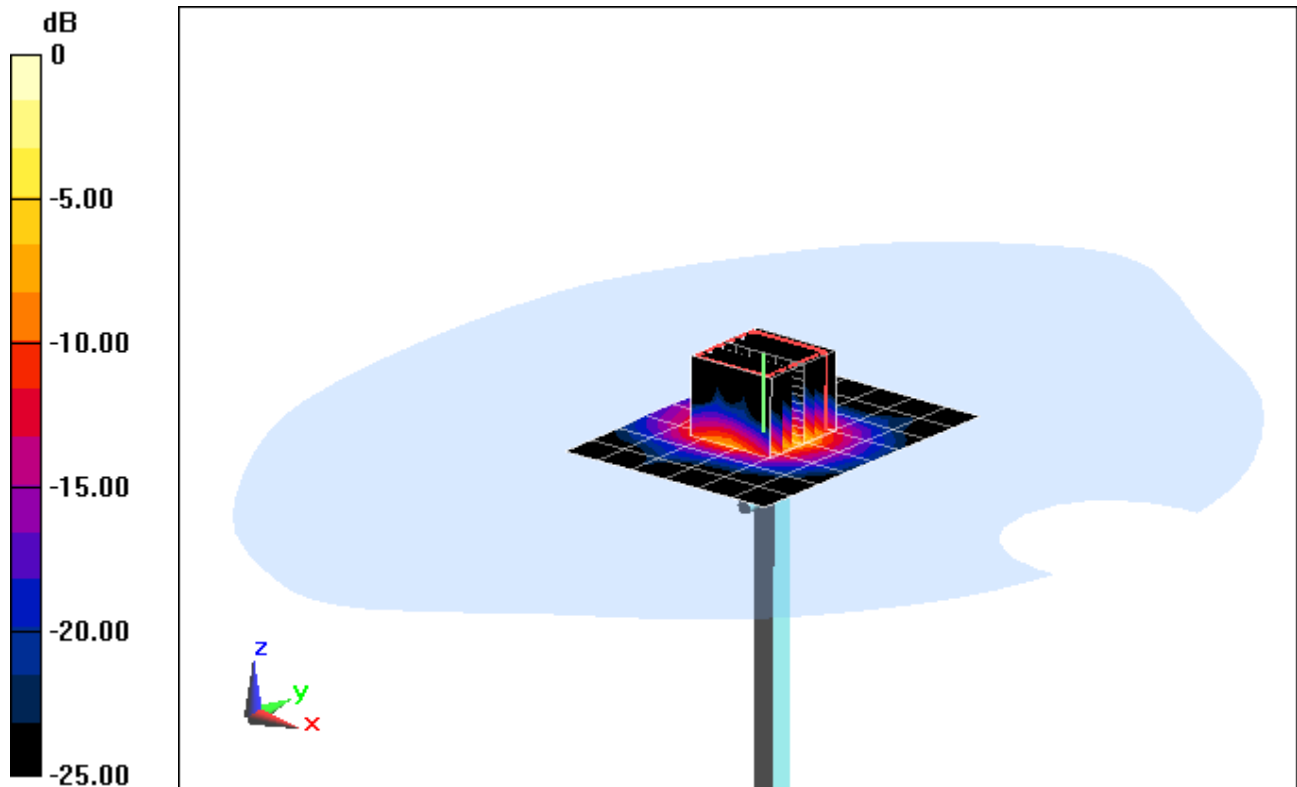

0 dB = 15.5 mW/g = 23.81 dB mW/g

PCTEST ENGINEERING LABORATORY, INC.

DUT: Dipole 5800 MHz; Type: D5GHzV2; Serial: 1057

Communication System: CW; Frequency: 5800 MHz; Duty Cycle: 1:1

Medium: 5GHz Body Medium parameters used:

$f = 5800 \text{ MHz}$; $\sigma = 6.191 \text{ mho/m}$; $\epsilon_r = 46.66$; $\rho = 1000 \text{ kg/m}^3$

Phantom section: Flat Section; Space: 1.0 cm

Test Date: 08-27-2012; Ambient Temp: 24.5°C; Tissue Temp: 23.6°C

Probe: EX3DV4 - SN3589; ConvF(3.59, 3.59, 3.59); Calibrated: 1/27/2012;

Sensor-Surface: 2mm (Mechanical Surface Detection)

Electronics: DAE4 Sn1323; Calibrated: 2/15/2012

Phantom: SAM Main; Type: SAM 4.0; Serial: TP-1114

Measurement SW: DASY4, Version 4.7 (80); SEMCAD X Version 14.6.5 (6469)

5800 MHz System Verification

Area Scan (7x9x1): Measurement grid: dx=10mm, dy=10mm

Zoom Scan (7x7x11)/Cube 0: Measurement grid: dx=4mm, dy=4mm, dz=2mm

Input Power: 20.0 dBm (100 mW)

Peak SAR (extrapolated) = 32.035 mW/g

SAR(1 g) = 7.08 mW/g; SAR(10 g) = 1.91 mW/g

Deviation = -4.71%

