

TEST REPORT

of

FCC Part 15 Subpart C §15.225

FCC ID : A3L-EFNG935

Equipment Under Test : LED View Cover
Model Name : EF-NG935
Applicant : Samsung Electronics Co., Ltd.
Manufacturer : Samsung Electronics Co., Ltd.
Date of Test(s) : 2015.12.23 ~ 2015.12.30
Date of Issue : 2016.01.13

In the configuration tested, the EUT complied with the standards specified above.

Tested By:



Date:

2016.01.13

Patrick Kang

Approved By:



Date:

2016.01.13

Hyunchaeh You

The results shown in this test report refer only to the sample(s) tested unless otherwise stated. This test report cannot be reproduced, except in full, without prior written permission of the Company.

SGS Korea Co., Ltd. (Gunpo Laboratory) 4, LS-ro 182beon-gil, Gunpo-si, Gyeonggi-do, Korea, 15807 <http://www.sgsgroup.kr>

INDEX

<u>TABLE OF CONTENTS</u>	Page
1. General Information -----	3
2. Radiated Emissions -----	6
3. Frequency Stability -----	12
4. 20 dB Bandwidth -----	14
5. AC Power Line Conducted Emissions -----	16

The results shown in this test report refer only to the sample(s) tested unless otherwise stated. This test report cannot be reproduced, except in full, without prior written permission of the Company.

SGS Korea Co., Ltd. (Gunpo Laboratory) 4, LS-ro 182beon-gil, Gunpo-si, Gyeonggi-do, Korea, 15807 <http://www.sgsgroup.kr>

1. General Information

1.1. Testing Laboratory

SGS Korea Co., Ltd. (Gunpo Laboratory)

- Wireless Div. 2FL, 10-2, LS-ro 182beon-gil, Gunpo-si, Gyeonggi-do, Korea, 15807

All SGS services are rendered in accordance with the applicable SGS conditions of service available on request and accessible at <http://www.sgs.com/en/Terms-and-Conditions.aspx>.

Phone No. : +82 31 688 0901

Fax No. : +82 31 688 0921

1.2. Details of Applicant

Applicant : Samsung Electronics Co., Ltd.

Address : 129, Samsung-ro, Yeongtong-gu, Suwon-si, Gyeonggi-do, 16677 Rep. of Korea

Contact Person : Ko, Kang-Ho

Phone No. : +82 31 301 1107

1.3. Description of EUT

Kind of Product	LED View Cover
Model Name	EF-NG935
Power Supply (EUT)	DC 3.0 V (used by host equipment voltage – DC 4.0 V)
Frequency Range	13.56 MHz (NFC)
Modulation Technique	ASK
Number of Channels	1 channel
Antenna Type	Internal type
H/W Version	REV1.0
S/W Version	REV1.0

1.4. Declarations by The manufacturer

While the EUT operates NFC mode, it is directly supported voltage by host equipment through NFC antenna. For that reason, voltage of EUT could not be changed by DC power supply. Therefore measurement was investigated by setting voltage of host equipment.

The results shown in this test report refer only to the sample(s) tested unless otherwise stated. This test report cannot be reproduced, except in full, without prior written permission of the Company.

SGS Korea Co., Ltd. (Gunpo Laboratory) 4, LS-ro 182beon-gil, Gunpo-si, Gyeonggi-do, Korea, 15807 <http://www.sgsgroup.kr>

1.5. Test Equipment List

Equipment	Manufacturer	Model	S/N	Cal. Date	Cal. Interval	Cal. Due
Signal Generator	R&S	SMBV100A	259067	Jun. 22, 2015	Annual	Jun. 22, 2016
Spectrum Analyzer	R&S	FSV30	100955	Mar. 24, 2015	Annual	Mar. 24, 2016
High Pass Filter	Mini circuits	NHP-25+	V9741901107	Mar. 13, 2015	Annual	Mar. 13, 2016
DC Power Supply	Agilent	U8002A	MY49030063	Dec. 03, 2015	Annual	Dec. 03, 2016
Temperature Chamber	ESPEC CORP.	PL-1J	15000793	Jun. 22, 2015	Annual	Jun. 22, 2016
Preamplifier	H.P.	8447F	2944A03909	Aug. 27, 2015	Annual	Aug. 27, 2016
Bilog Antenna	SCHWARZBECK MESSELEKTRONIK	VULB9163	396	Jun. 18, 2015	Biennial	Jun. 18, 2017
Loop Antenna	R&S	HFH2-Z2	100118	Jun. 04, 2015	Biennial	Jun. 04, 2017
Test Receiver	R&S	ESU26	100109	Mar. 03, 2015	Annual	Mar. 03, 2016
Test Receiver	R&S	ESCI 7	100911	Dec. 22, 2015	Annual	Dec. 22, 2016
Antenna Master	INN-CO	MM4000	N/A	N/A	N/A	N.C.R.
Turn Table	INN-CO	DS 1200 S	N/A	N/A	N/A	N.C.R.
Anechoic Chamber	SY Corporation	L x W x H (9.6 m x 6.4 m x 6.6 m)	N/A	N/A	N/A	N.C.R.
Two-Line V-Network	R&S	ENV216	100190	Dec. 21, 2015	Annual	Dec. 21, 2016
Shield Room	SY Corporation	L x W x H (6.5 m x 3.5 m x 3.5 m)	N/A	N.C.R.	N/A	N.C.R.
Attenuator	AEROFLEX / INMET	26A-10dB	3	Mar. 16, 2015	Annual	Mar. 16, 2016

1.6. Host Equipment

Description	Manufacturer	Model
Mobile phone	Samsung Electronics Co., Ltd.	SM-G935

The results shown in this test report refer only to the sample(s) tested unless otherwise stated. This test report cannot be reproduced, except in full, without prior written permission of the Company.

SGS Korea Co., Ltd. (Gunpo Laboratory) 4, LS-ro 182beon-gil, Gunpo-si, Gyeonggi-do, Korea, 15807 <http://www.sgsgroup.kr>

1.7. Summary of Test Results

The EUT has been tested according to the following specifications:

Applied standard : FCC Part15 subpart C		
Standard section	Test item	Result
15.225(a)(b)(c)(d) 15.209	Radiated Emissions	Complied
15.225(e)	Frequency Stability	Complied
15.215(c)	20 dB Bandwidth	Complied
15.207	AC Power Line Conducted Emissions	Complied

1.8. Sample calculation

Where relevant, the following sample calculation is provided:

1.8.1. Conducted test

Offset value (dB) = Attenuator(dB) + Cable loss (dB)

1.8.2. Radiation test

Field strength level (dB μ V/m) = Measured level (dB μ V) + Antenna factor (dB) + Cable loss (dB) - amplifier (dB)

1.9. Test report revision

Revision	Report number	Date of Issue	Description
0	F690501/RF-RTL009370	2015.12.31	Initial
1	F690501/RF-RTL009370-1	2016.01.13	Changed FCC ID

The results shown in this test report refer only to the sample(s) tested unless otherwise stated. This test report cannot be reproduced, except in full, without prior written permission of the Company.

SGS Korea Co., Ltd. (Gunpo Laboratory) 4, LS-ro 182beon-gil, Gunpo-si, Gyeonggi-do, Korea, 15807 <http://www.sgsgroup.kr>

2. Radiated Emissions

2.1. Test Setup

The diagram below shows the test setup that is utilized to make the measurements for emission from 9 kHz to 30 MHz Emissions.

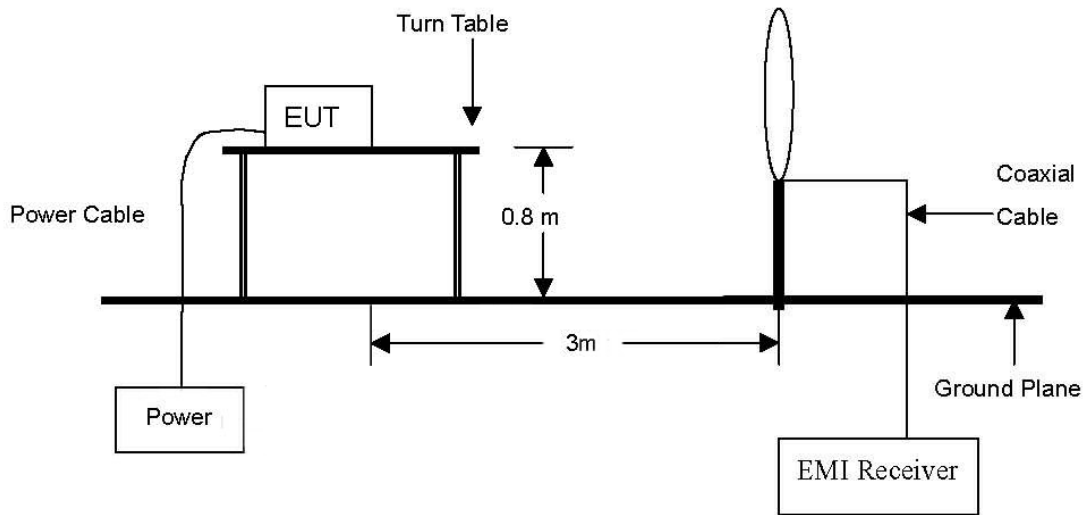

The diagram below shows the test setup that is utilized to make the measurements for emission from 30 MHz to 1 GHz Emissions.

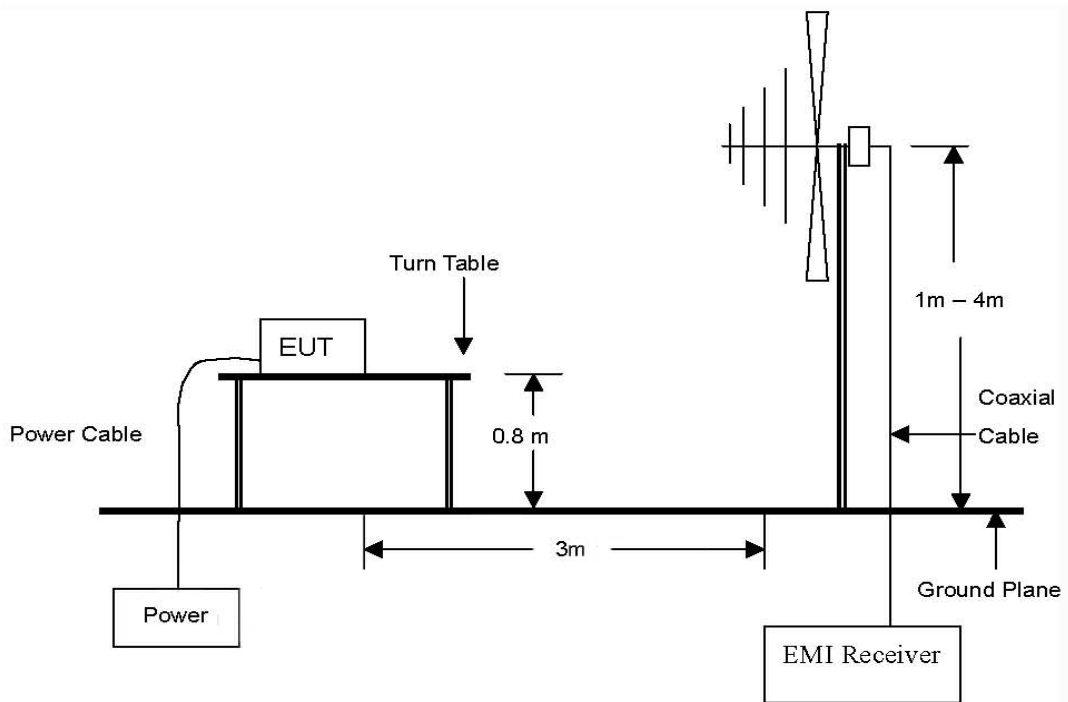

The results shown in this test report refer only to the sample(s) tested unless otherwise stated. This test report cannot be reproduced, except in full, without prior written permission of the Company.

2.2. Limit

2.2.1. Operation within the band 13.110 – 14.010 MHz.

According to §15.225,

- (a) The field strength of any emissions within the band 13.553 - 13.567 MHz shall not exceed 15 848 microvolts / meter at 30 meters.
- (b) Within the bands 13.410 - 13.553 MHz and 13.567 - 13.710 MHz, the field strength of any emissions shall not exceed 334 microvolts / meter at 30 meters.
- (c) Within the bands 13.110 - 13.410 MHz and 13.710 - 14.010 MHz the field strength of any emissions shall not exceed 106 microvolts / meter at 30 meters.
- (d) The field strength of any emissions appearing outside of the 13.110 - 14.010 MHz and shall not exceed the general radiated emission limits in §15.209.

According to §15.209,

Except as provided elsewhere in this Subpart, the emissions from an intentional radiator shall not exceed the field strength levels specified in the following table:

Frequency (MHz)	Field Strength (microvolts/meter)	Measurement Distance (meter)
0.009 – 0.490	2400/F(kHz)	300
0.490 – 1.705	24000/F(kHz)	30
1.705 – 30.0	30	30
30 -88	100**	3
88 -216	150**	3
216 - 960	200**	3
Above 960	500	3

** Except as provided in paragraph (g), fundamental emissions from intentional radiators operating under this Section shall not be located in the frequency bands 54-72 MHz, 76-88 MHz, 174-216 MHz or 470-806 MHz. However, operation within these frequency bands is permitted under other sections of this Part, e.g., Sections 15.231 and 15.241

The results shown in this test report refer only to the sample(s) tested unless otherwise stated. This test report cannot be reproduced, except in full, without prior written permission of the Company.

2.3. Test Procedures

Radiated emissions from the EUT were measured according to the dictates of ANSI C63.10-2009.

2.3.1. Test Procedures for emission below 30 MHz

1. The EUT was placed on the top of a rotating table 0.8 meters above the ground at a 3 meter anechoic chamber test site. The table was rotated 360 degrees to determine the position of the highest radiation.
2. Then antenna is a loop antenna is fixed at one meter above the ground to determine the maximum value of the field strength. Both parallel and perpendicular of the antenna are set to make the measurement.
3. For each suspected emission, the EUT was arranged to its worst case and then the table was turned from 0 degrees to 360 degrees to find the maximum reading.
4. The test-receiver system was set to Quasi peak Detect Function with Maximum Hold Mode.

Note;

Although these tests were performed other than open field test site, adequate comparison measurements were confirmed against 30 meter open field test site. Therefore sufficient tests were made to demonstrate that the alternative site produces results that correlate with the ones of tests made in an open field based on KDB 937606.

2.3.2. Test Procedures for emission above 30 MHz

1. The EUT was placed on the top of a rotating table 0.8 meters above the ground at a 3 meter anechoic chamber test site. The table was rotated 360 degrees to determine the position of the highest radiation.
2. During performing radiated emission below 1 GHz, the EUT was set 3 meters away from the interference receiving antenna, which was mounted on the top of a variable-height antenna tower.
3. The antenna is a bi-log antenna and its height is varied from one meter to four meters above the ground to determine the maximum value of the field strength. Both horizontal and vertical polarizations of the antenna are set to make the measurement.
4. For each suspected emission, the EUT was arranged to its worst case and then the antenna was tuned to heights from 1 meter to 4 meters and the table was turned from 0 degrees to 360 degrees to find the maximum reading.
5. The test-receiver system was set to Peak Detect Function and Specified Bandwidth with Maximum Hold Mode.
6. If the emission level of the EUT in peak mode was 10 dB lower than the limit specified, then testing could be stopped and the peak values of the EUT would be reported. Otherwise the emissions that did not have 10 dB margin would be re-tested one by one using peak, quasi-peak or average method as specified and then reported in a data sheet.

NOTE;

To get a maximum emission level from the EUT, the EUT is manipulated through three orthogonal planes (X, Y, Z). Worst orthogonal plan of EUT is **Y – axis** during radiation test.

The results shown in this test report refer only to the sample(s) tested unless otherwise stated. This test report cannot be reproduced, except in full, without prior written permission of the Company.

SGS Korea Co., Ltd. (Gunpo Laboratory) 4, LS-ro 182beon-gil, Gunpo-si, Gyeonggi-do, Korea, 15807 <http://www.sgsgroup.kr>

2.4. Test Result

Ambient temperature : (23 ± 1) °C

Relative humidity : 47 % R.H.

The following table shows the highest levels of radiated emissions.

-Fundamental within the band 13.553 MHz – 13.567 MHz

Radiated Emissions			Ant.	Correction Factors		Total		FCC Limit	
Freq. (MHz)	Reading (dB μ V)	Detect Mode	Pol.	Ant. Factor (dB/m)	Cable loss (dB)	Actual (dB μ V/m) at 3 m	Actual (dB μ V/m) at 30 m	Limit (dB μ V/m) at 30 m	Margin (dB)
13.560	31.50	Quasi-Peak	H	18.67	0.42	50.59	10.59	84.00	73.41

-Spurious emission within the bands 13.410 MHz – 13.553 MHz and 13.567 MHz – 13.710 MHz

Radiated Emissions			Ant.	Correction Factors		Total		FCC Limit	
Freq. (MHz)	Reading (dB μ V)	Detect Mode	Pol.	Ant. Factor (dB/m)	Cable loss (dB)	Actual (dB μ V/m) at 3 m	Actual (dB μ V/m) at 30 m	Limit (dB μ V/m) at 30 m	Margin (dB)
13.548	7.50	Quasi-Peak	H	18.67	0.42	26.59	-13.41	50.47	63.88
13.672	6.90	Quasi-Peak	H	18.66	0.42	25.98	-14.02	50.47	64.49

- Spurious emission within the bands 13.110 MHz – 13.410 MHz and 13.710 MHz – 14.010 MHz

Radiated Emissions			Ant.	Correction Factors		Total		FCC Limit	
Freq. (MHz)	Reading (dB μ V)	Detect Mode	Pol.	Ant. Factor (dB/m)	Cable loss (dB)	Actual (dB μ V/m) at 3 m	Actual (dB μ V/m) at 30 m	Limit (dB μ V/m) at 30 m	Margin (dB)
13.349	9.30	Quasi-Peak	H	18.70	0.42	28.42	-11.58	40.51	52.09
13.772	6.20	Quasi-Peak	H	18.65	0.42	25.27	-14.73	40.51	55.24

The results shown in this test report refer only to the sample(s) tested unless otherwise stated. This test report cannot be reproduced, except in full, without prior written permission of the Company.

SGS Korea Co., Ltd. (Gunpo Laboratory) 4, LS-ro 182beon-gil, Gunpo-si, Gyeonggi-do, Korea, 15807 <http://www.sgsgroup.kr>

- Spurious emission within the bands 9 kHz – 13.110 MHz

Radiated Emissions			Ant.	Correction Factors		Total		FCC Limit	
Freq. (MHz)	Reading (dB μ V)	Detect Mode	Pol.	Ant. Factor (dB/m)	Cable loss (dB)	Actual (dB μ V/m) at 3 m	Actual (dB μ V/m) at 300 m	Limit (dB μ V/m) at 300 m	Margin (dB)
*0.093	-6.30	Quasi-Peak	H	19.61	0.05	13.36	-66.64	28.23	94.87

Radiated Emissions			Ant.	Correction Factors		Total		FCC Limit	
Freq. (MHz)	Reading (dB μ V)	Detect Mode	Pol.	Ant. Factor (dB/m)	Cable loss (dB)	Actual (dB μ V/m) at 3 m	Actual (dB μ V/m) at 30 m	Limit (dB μ V/m) at 30 m	Margin (dB)
*12.577	6.10	Quasi-Peak	H	18.79	0.41	25.30	-14.70	29.54	44.24

- Spurious emission within the bands 14.010 MHz – 30 MHz

Radiated Emissions			Ant.	Correction Factors		Total		FCC Limit	
Freq. (MHz)	Reading (dB μ V)	Detect Mode	Pol.	Ant. Factor (dB/m)	Cable loss (dB)	Actual (dB μ V/m) at 3 m	Actual (dB μ V/m) at 30 m	Limit (dB μ V/m) at 30 m	Margin (dB)
14.266	6.30	Quasi-Peak	H	18.59	0.42	25.31	-14.69	29.54	44.23
*16.423	6.50	Quasi-Peak	H	18.47	0.43	25.40	-14.60	29.54	44.14

The results shown in this test report refer only to the sample(s) tested unless otherwise stated. This test report cannot be reproduced, except in full, without prior written permission of the Company.

- Spurious emission above 30 MHz

Radiated Emissions			Ant.	Correction Factors		Total	FCC Limit	
Freq. (MHz)	Reading (dB μ V)	Detect Mode	Pol.	Ant. Factor (dB/m)	Cable loss & Amp (dB)	Actual (dB μ V/m) at 3 m	Limit (dB μ V/m) at 3 m	Margin (dB)
40.67	43.10	Peak	H	15.96	-27.15	31.91	40.00	8.09
40.67	49.90	Peak	V	14.06	-27.15	36.81	40.00	3.19
67.79	43.80	Peak	H	11.11	-26.85	28.06	40.00	11.94
67.79	45.50	Peak	V	10.85	-26.85	29.50	40.00	10.50
94.91	41.90	Peak	V	11.82	-26.68	27.04	43.50	16.46
366.15	48.50	Peak	H	15.95	-25.43	39.02	46.00	6.98
Above 400.000	Not detected	-	-	-	-	-	-	-

Note:

1. Fundamental limit (μ V/m) = $20 \log (15\ 848) = 84.00$ dB μ V/m.
2. 30 m distance compensation = $40 \log (3/30) = -40$ dB μ V/m.
3. 300 m distance compensation = $40 \log (3/300) = -80$ dB μ V/m.
4. Other spurious emission frequencies were not detected up to 1 000 MHz.
5. “*” means the restricted band.
6. If the spurious emissions are in the restricted band, the limit complied with §15.209.

The results shown in this test report refer only to the sample(s) tested unless otherwise stated. This test report cannot be reproduced, except in full, without prior written permission of the Company.

3. Frequency Stability

3.1. Test Setup

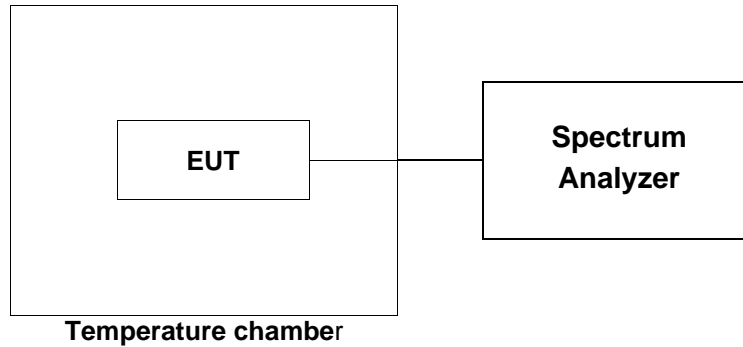

3.2. Limit

According to §15.225(e), the frequency tolerance of the carrier signal shall be maintained within +/- 0.01 % of the operating frequency over a temperature variation of -20 degrees to +50 degrees C at normal supply voltage, and for a variation in the primary supply voltage from 85 % to 115 % of the rated supply voltage at a temperature of 20 degrees C. For battery operated equipment, the equipment tests shall be performed using a new battery.

3.3. Test Procedures

1. Place the EUT on the table and set it in the transmitting mode.
2. Remove the antenna from the EUT and then connect a low loss RF cable from the antenna port to the spectrum analyzer.
3. Set the environment into appropriate environment.
4. Set the spectrum analyzer as RBW = 30 Hz, VBW = 100 Hz, Span = 2 kHz, Sweep time = auto.
5. Mark the peak frequency and measure the frequency tolerance using frequency counter function.
6. Repeat until all the results are investigated.

The results shown in this test report refer only to the sample(s) tested unless otherwise stated. This test report cannot be reproduced, except in full, without prior written permission of the Company.

3.4. Test Result

Ambient temperature : (23 ± 1) °C
 Relative humidity : 47 % R.H.

Operating Frequency : 13 560 000 Hz
 Reference Voltage: DC 4.0 V (Host Equipment)
 Deviation Limit : ± 0.01 % = ± 1 356 Hz

Temperature Variations

Power (V _{DC})	Temperature (°C)	Frequency (Hz)	Freq. Dev. (Hz)	Deviation (%)
4.0	-20	13 560 006	6	0.000 044
	-10	13 560 004	4	0.000 029
	0	13 560 002	2	0.000 015
	+10	13 560 002	2	0.000 015
	+20	13 560 002	2	0.000 015
	+30	13 560 002	2	0.000 015
	+40	13 560 002	2	0.000 015
	+50	13 560 002	2	0.000 015

Voltage Variations

Power (V _{DC})	Temperature (°C)	Frequency (Hz)	Freq. Dev. (Hz)	Deviation (%)
115 % (4.6)	+20	13 560 002	2	0.000 015
85 % (3.4)	+20	13 560 002	2	0.000 015

The results shown in this test report refer only to the sample(s) tested unless otherwise stated. This test report cannot be reproduced, except in full, without prior written permission of the Company.

4. 20 dB Bandwidth

4.1. Test Setup

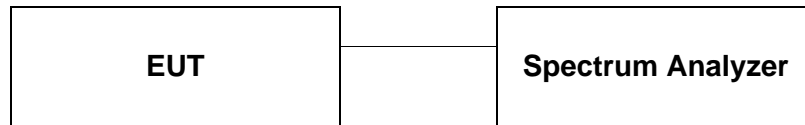

4.2. Limit

None ; for reporting purposes only.

4.3. Test Procedures

1. Place the EUT on the table and set it in the transmitting mode.
2. Remove the antenna from the EUT and then connect a low loss RF cable from the antenna port to the spectrum analyzer.
3. Set the spectrum analyzer as RBW = 10 kHz, VBW = 30 kHz, Span = 2 MHz, Sweep time = auto.
4. Mark the peak frequency and 20 dB (upper and lower) frequency.

The results shown in this test report refer only to the sample(s) tested unless otherwise stated. This test report cannot be reproduced, except in full, without prior written permission of the Company.

SGS Korea Co., Ltd. (Gunpo Laboratory) 4, LS-ro 182beon-gil, Gunpo-si, Gyeonggi-do, Korea, 15807 <http://www.sgsgroup.kr>

4.4. Test Result

Ambient temperature : (23 ± 1) °C
 Relative humidity : 47 % R.H.

Frequency (MHz)	20 dB Bandwidth (kHz)
13.560	437.6

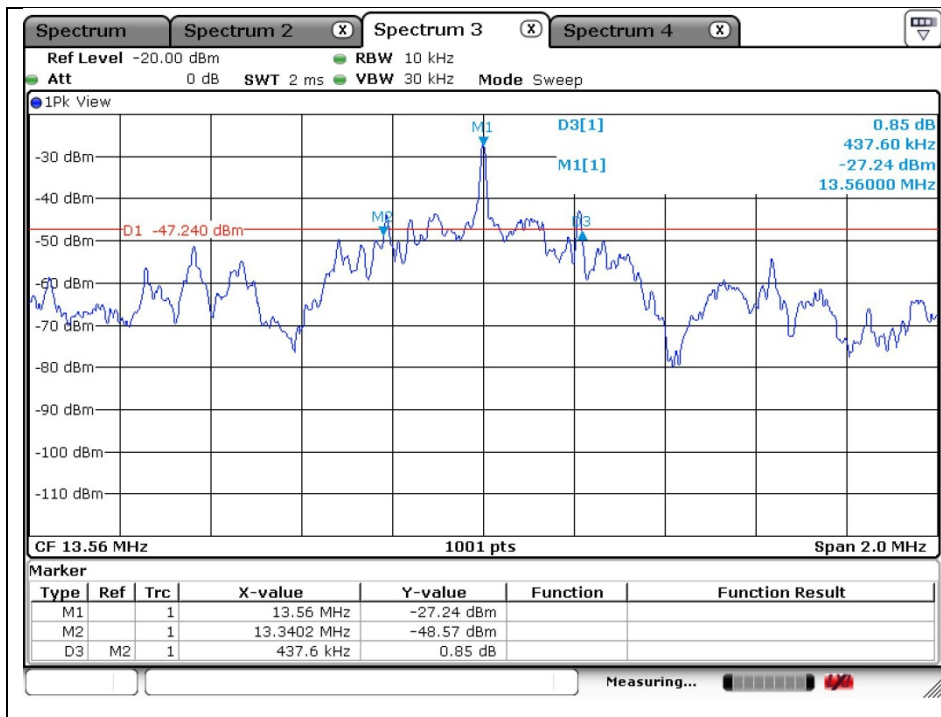

The results shown in this test report refer only to the sample(s) tested unless otherwise stated. This test report cannot be reproduced, except in full, without prior written permission of the Company.

5. AC Power Line Conducted Emissions

5.1. Test Setup

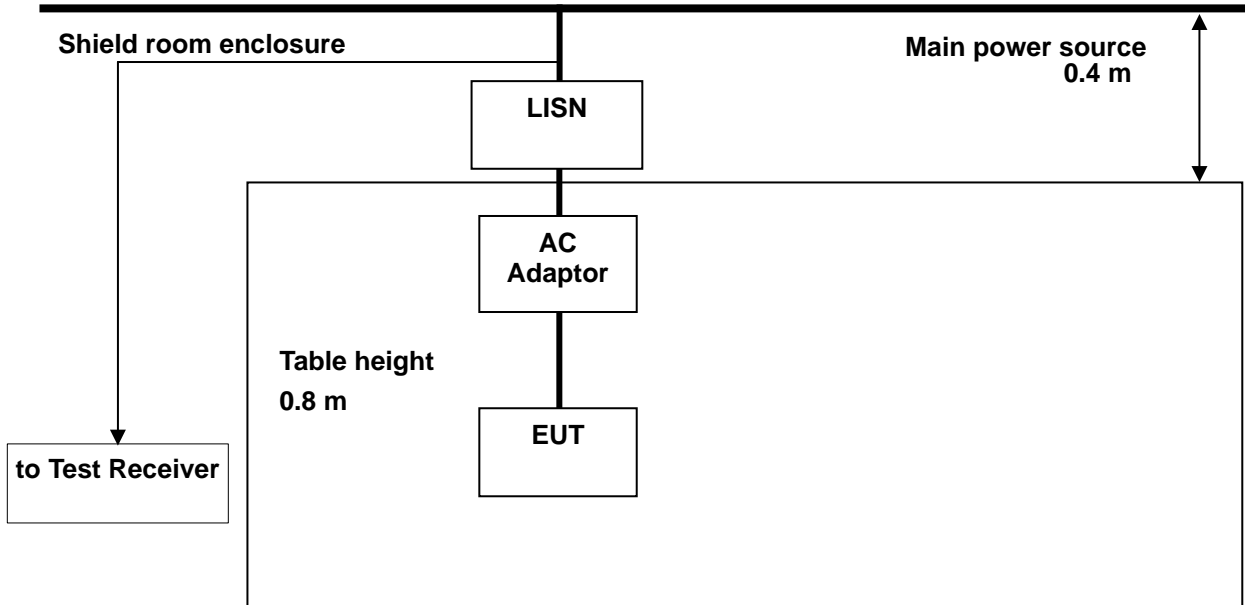

5.2. Limit

According to §15.207(a) for an intentional radiator that is designed to be connected to the public utility (AC) power line, the radio frequency voltage that is conducted back onto the AC power line on any frequency or frequencies, within the band 150 kHz to 30 MHz, shall not exceed the limits in the following table, as measured using a 50 μ H / 50 ohm line impedance stabilization network(LISN).

Compliance with the provision of this paragraph shall on the measurement of the radio frequency voltage between each power line and ground at the power terminal. The lower applies at the boundary between the frequency ranges.

Frequency of Emission (MHz)	Conducted limit (dB μ V)	
	Quasi-peak	Average
0.15 – 0.50	66 - 56*	56 - 46*
0.50 – 5.00	56	46
5.00 – 30.0	60	50

* Decreases with the logarithm of the frequency.

The results shown in this test report refer only to the sample(s) tested unless otherwise stated. This test report cannot be reproduced, except in full, without prior written permission of the Company.

SGS Korea Co., Ltd. (Gunpo Laboratory) 4, LS-ro 182beon-gil, Gunpo-si, Gyeonggi-do, Korea, 15807 <http://www.sgsgroup.kr>

5.3. Test Procedures

AC power line conducted emissions from the EUT were measured according to the dictates of ANSI C63.10-2009

1. The test procedure is performed in a 6.5 m × 3.5 m × 3.5 m (L × W × H) shielded room. The EUT along with its peripherals were placed on a 1.0 m (W) × 1.5 m (L) and 0.8 m in height wooden table and the EUT was adjusted to maintain a 0.4 meter space from a vertical reference plane.
2. The EUT was connected to power mains through a line impedance stabilization network (LISN) which provides 50 ohm coupling impedance for measuring instrument and the chassis ground was bounded to the horizontal ground plane of shielded room.
3. The excess power cable between the EUT and the LISN was bundled. All connecting cables of EUT were moved to find the maximum emission.

The results shown in this test report refer only to the sample(s) tested unless otherwise stated. This test report cannot be reproduced, except in full, without prior written permission of the Company.

SGS Korea Co., Ltd. (Gunpo Laboratory) 4, LS-ro 182beon-gil, Gunpo-si, Gyeonggi-do, Korea, 15807 <http://www.sgsgroup.kr>

5.4. Test Results

The following table shows the highest levels of conducted emissions on both phase of Hot and Neutral line.

Ambient temperature : (23 ± 1) °C
 Relative humidity : 47 % R.H.
 Frequency range : 0.15 MHz - 30 MHz
 Measured Bandwidth : 9 kHz

FREQ. (MHz)	LEVEL(dB μ V)		LINE	LIMIT(dB μ V)		MARGIN(dB)	
	Quasi Peak	Average		Quasi Peak	Average	Quasi Peak	Average
0.27	38.30	22.40	N	61.12	51.12	22.82	28.72
0.40	36.30	22.50	N	57.85	47.85	21.55	25.35
0.67	35.00	22.10	N	56.00	46.00	21.00	23.90
10.69	38.90	32.60	N	60.00	50.00	21.10	17.40
13.20	42.00	36.40	N	60.00	50.00	18.00	13.60
15.98	42.10	36.00	N	60.00	50.00	17.90	14.00
0.28	36.70	22.00	H	60.82	50.82	24.12	28.82
0.42	36.80	21.60	H	57.45	47.45	20.65	25.85
0.84	36.20	22.10	H	56.00	46.00	19.80	23.90
1.09	35.40	20.70	H	56.00	46.00	20.60	25.30
13.57	51.80	45.30	H	60.00	50.00	8.20	4.70
15.02	42.40	30.10	H	60.00	50.00	17.60	19.90

Note;

1. Line (H): Hot, Line (N): Neutral
2. The limit for Class B device(s) from 150 kHz to 30 MHz are specified in Section of the Title 47 CFR.
3. Traces shown in plot made using a peak detector and average detector.
4. Deviations to the Specifications: None.

The results shown in this test report refer only to the sample(s) tested unless otherwise stated. This test report cannot be reproduced, except in full, without prior written permission of the Company.

Plots of Conducted Power line

Test mode: (Neutral)

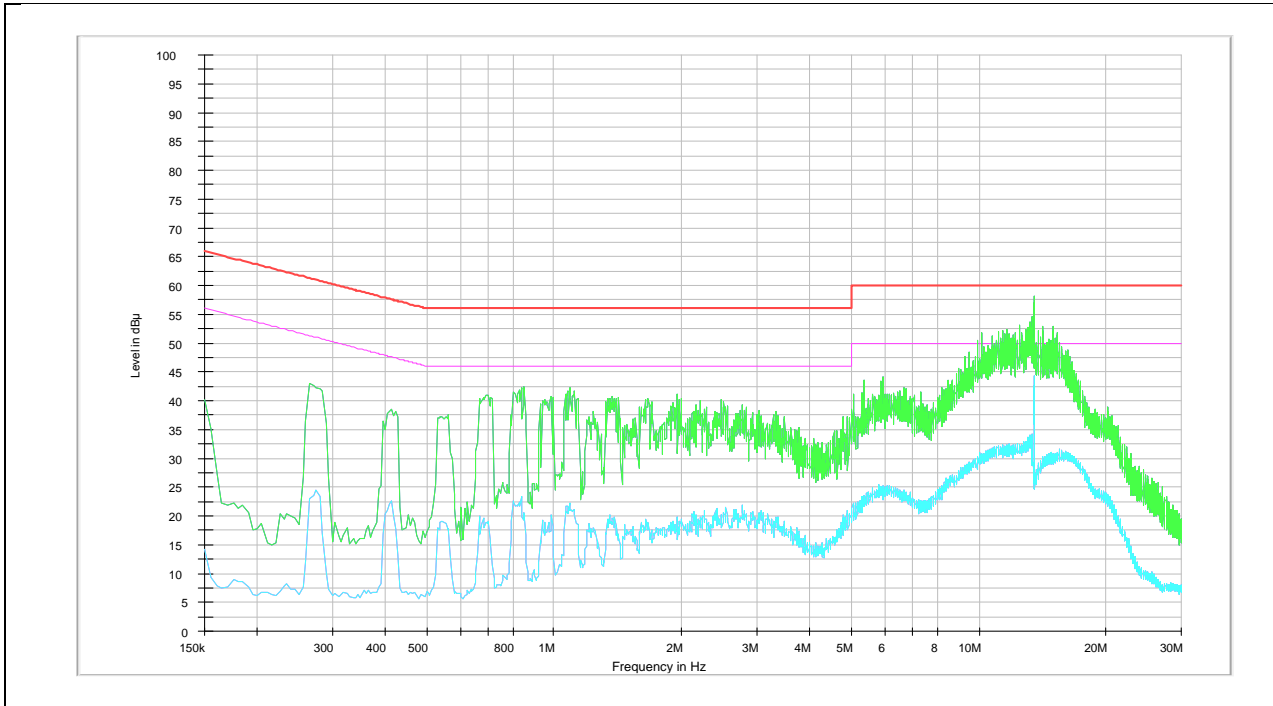

Test mode: (Hot)

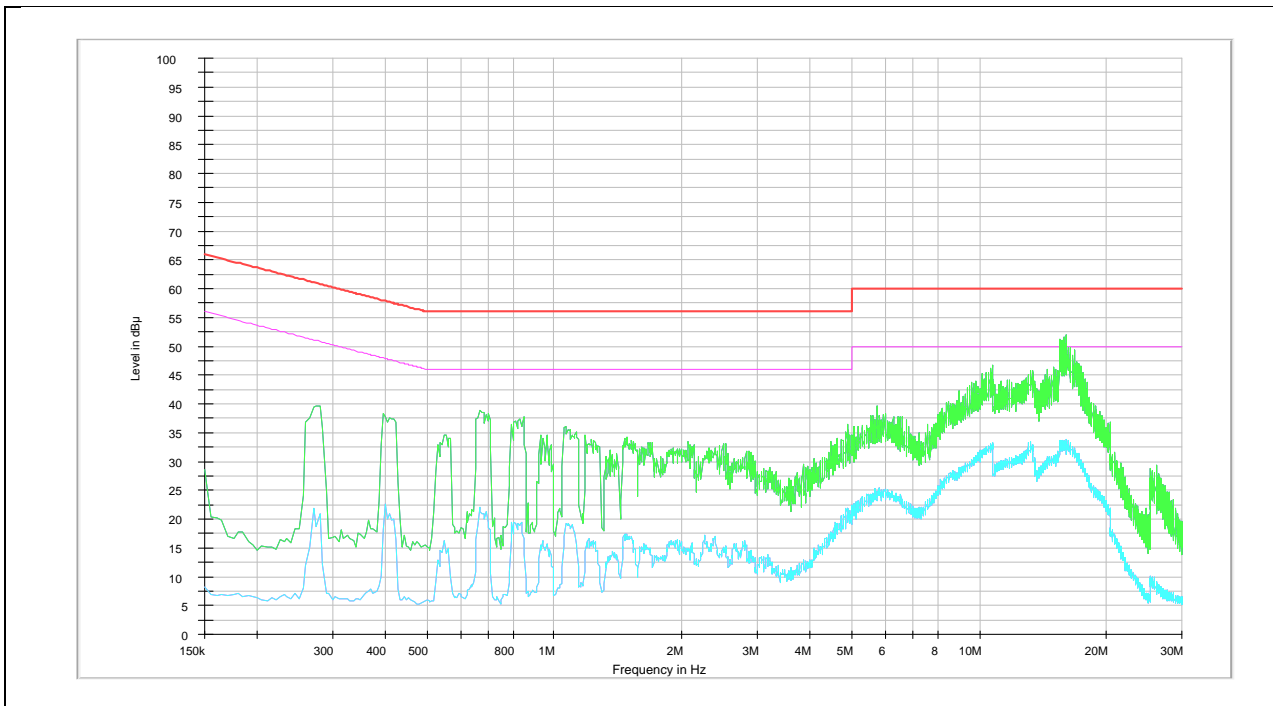

The results shown in this test report refer only to the sample(s) tested unless otherwise stated. This test report cannot be reproduced, except in full, without prior written permission of the Company.