

Note:

Offset (dB) = Attenuator(dB) + Cable loss (dB)

Result (dB m) = Spurious offset (dB) + Reading values (dB m)

Frequency (MHz)	Spurious offset (dB)	Reading values (dB m)	Result (dB m)
3 709.70	11.59	-56.21	-45.39
25 678.80	Noise Level	-	-

The results shown in this test report refer only to the sample(s) tested unless otherwise stated. This test report cannot be reproduced, except in full, without prior written permission of the Company.

High Channel

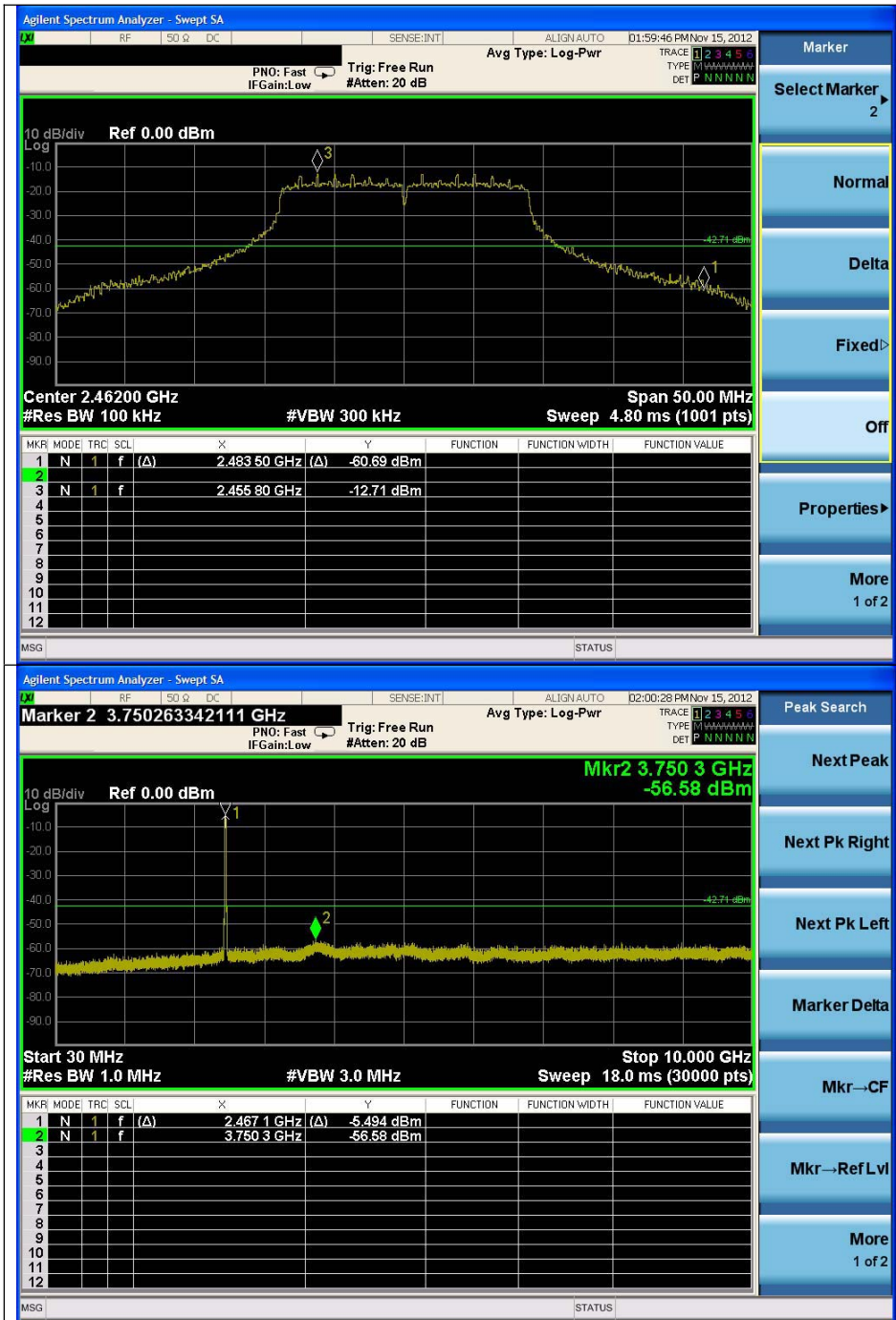

The results shown in this test report refer only to the sample(s) tested unless otherwise stated. This test report cannot be reproduced, except in full, without prior written permission of the Company.

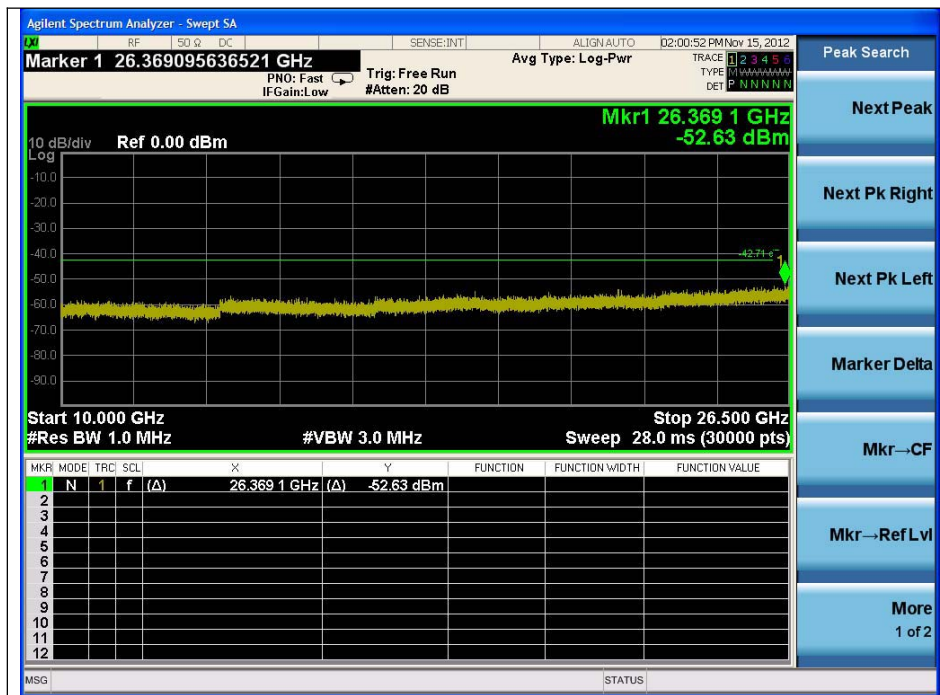

Note:

Offset (dB) = Attenuator(dB) + Cable loss (dB)

Result (dB m) = Spurious offset (dB) + Reading values (dB m)

Frequency (MHz)	Spurious offset (dB)	Reading values (dB m)	Result (dB m)
2 483.50	10.82	-60.69	-49.87
3 750.30	11.59	-56.58	-44.99
26 369.10	Noise Level	-	-

The results shown in this test report refer only to the sample(s) tested unless otherwise stated. This test report cannot be reproduced, except in full, without prior written permission of the Company.

3. 6 dB Bandwidth Measurement and 99% Bandwidth

3.1. Test Setup

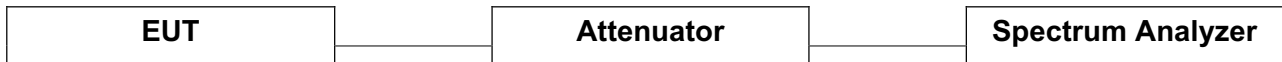

3.2. Limit

According to §15.247(a)(2), systems using digital modulation techniques may operate in the 902 ~928 MHz, 2 400 ~ 2 483.5 MHz, and 5 725 ~ 5 825 MHz bands. The minimum of 6 dB Bandwidth shall be at least 500 kHz

3.3. Test Procedure

3.3.1. 6 dB Bandwidth

All data rates and modes were investigated for this test. The full data for the worst case data rate are reported in this section.

The test follows section 7.1 of FCC KDB Publication 558074

1. Set resolution bandwidth (RBW) = 1 – 5 % or DTS BW, not to exceed 100 kHz
2. Set the video bandwidth (VBW) $\geq 3 \times$ RBW.
3. Detector = Peak.
4. Trace mode = max hold.
5. Sweep = auto couple.
6. Allow the trace to stabilize.
7. Measure the maximum width of the emission that is constrained by the frequencies associated with the two outermost amplitude point (upper and lower) that are attenuated by 6 dB relative to the maximum level measured in the fundamental emission.

3.3.2. 99% Bandwidth

The test follows section 4.6.1 of RSS-Gen

1. Set the spectrum analyzer as SPAN = 2 or 3 times necessary bandwidth
2. RBW = approximately 1 % of the SPAN
3. VBW is set to 3 times RBW
4. Detector = sampling
5. Trace mode = max hold.
6. Measure lowest and highest frequencies are placed in a running sum until 0.5 % and 99.5 % of the total is reached.
7. Record 99% occupied bandwidth between the lowest and the highest frequencies repeat measurement for all the test channels.

The results shown in this test report refer only to the sample(s) tested unless otherwise stated. This test report cannot be reproduced, except in full, without prior written permission of the Company.

3.4. Test Results

Ambient temperature : (24 ± 2) °C
 Relative humidity : 47 % R.H.

Operation Mode	Data Rate (Mbps)	Channel	Channel Frequency (MHz)	6 dB Bandwidth (MHz)	99 % Bandwidth (MHz)
DSSS (802.11b)	1	Low	2 412	10.10	13.91
		Middle	2 437	10.00	13.91
		High	2 462	10.10	13.86
OFDM (802.11g)	6	Low	2 412	16.45	17.41
		Middle	2 437	16.50	17.37
		High	2 462	16.45	17.38
OFDM (802.11n_HT20)	MCS0	Low	2 412	17.60	18.45
		Middle	2 437	17.60	18.40
		High	2 462	17.60	18.41

The results shown in this test report refer only to the sample(s) tested unless otherwise stated. This test report cannot be reproduced, except in full, without prior written permission of the Company.

6 dB Bandwidth

DSSS : 802.11b

Low Channel



Middle Channel



The results shown in this test report refer only to the sample(s) tested unless otherwise stated. This test report cannot be reproduced, except in full, without prior written permission of the Company.

High Channel



OFDM : 802.11g

Low Channel



The results shown in this test report refer only to the sample(s) tested unless otherwise stated. This test report cannot be reproduced, except in full, without prior written permission of the Company.

Middle Channel



High Channel



The results shown in this test report refer only to the sample(s) tested unless otherwise stated. This test report cannot be reproduced, except in full, without prior written permission of the Company.

OFDM : 802.11n_HT20

Low Channel



Middle Channel



The results shown in this test report refer only to the sample(s) tested unless otherwise stated. This test report cannot be reproduced, except in full, without prior written permission of the Company.

High Channel



The results shown in this test report refer only to the sample(s) tested unless otherwise stated. This test report cannot be reproduced, except in full, without prior written permission of the Company.

99% Bandwidth

DSSS : 802.11b

Low Channel

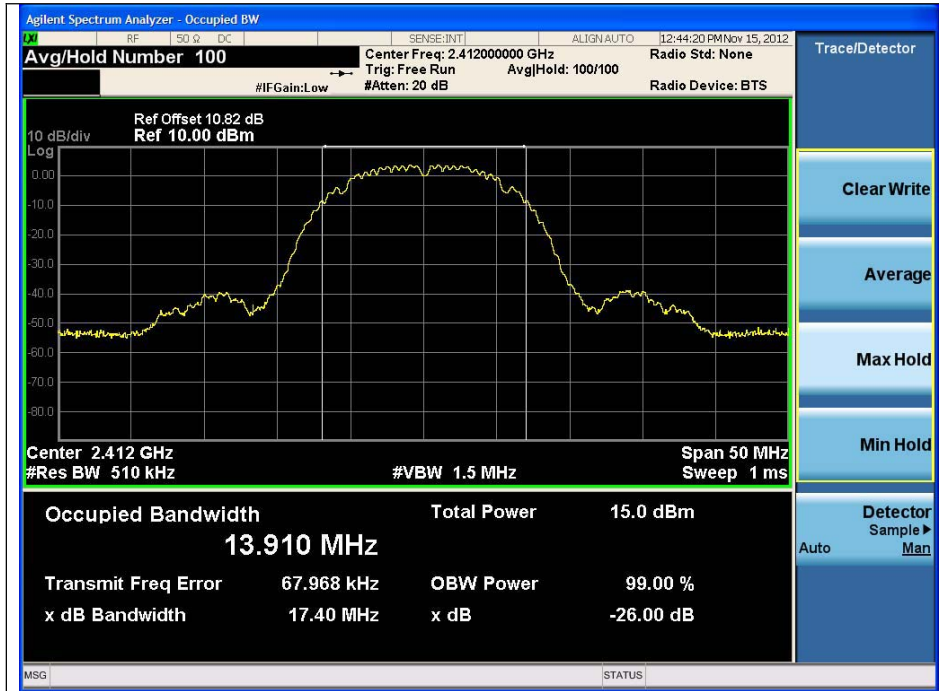

Middle Channel



The results shown in this test report refer only to the sample(s) tested unless otherwise stated. This test report cannot be reproduced, except in full, without prior written permission of the Company.

High Channel



OFDM : 802.11g

Low Channel



The results shown in this test report refer only to the sample(s) tested unless otherwise stated. This test report cannot be reproduced, except in full, without prior written permission of the Company.

Middle Channel



High Channel



The results shown in this test report refer only to the sample(s) tested unless otherwise stated. This test report cannot be reproduced, except in full, without prior written permission of the Company.

OFDM : 802.11n_HT20

Low Channel



Middle Channel



The results shown in this test report refer only to the sample(s) tested unless otherwise stated. This test report cannot be reproduced, except in full, without prior written permission of the Company.

High Channel

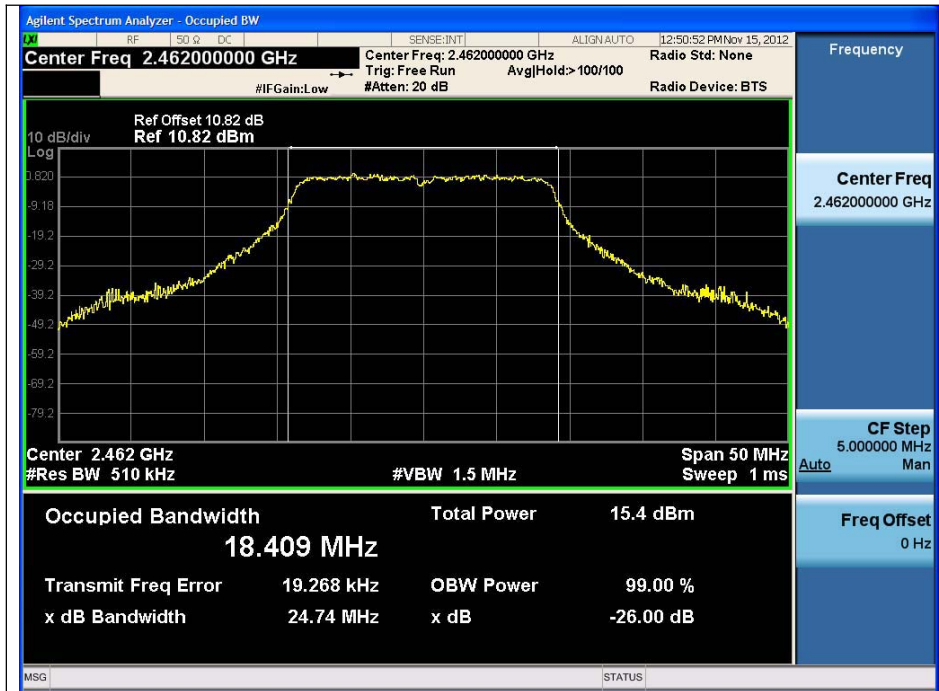

The results shown in this test report refer only to the sample(s) tested unless otherwise stated. This test report cannot be reproduced, except in full, without prior written permission of the Company.

4. Maximum Peak Output Power Measurement

4.1. Test Setup

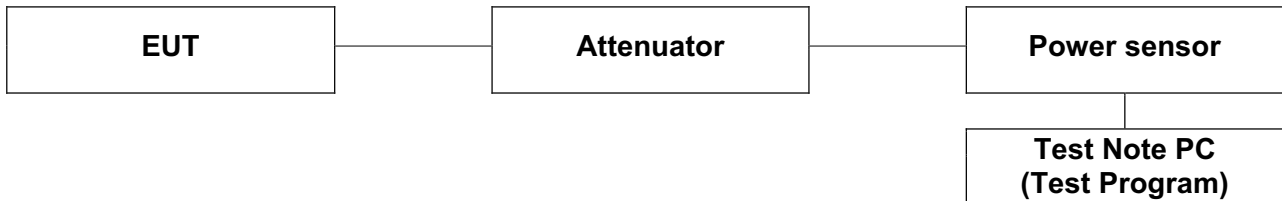

4.2. Limit

According to §15.247(b)(3), for systems using digital modulation in the 902 ~ 928 MHz, 2 400 ~2 483.5 MHz, and 5 725 ~ 5 850 MHz band: 1 Watt. As an alternative to a peak power measurement, compliance with the one watt limit can be based on a measurement of the maximum conducted output power. Maximum Conducted output Power is defined as the total transmit power delivered to all antennas and antenna elements averaged across all symbols in the signaling alphabet when the transmitter is operating at its maximum power control level. Power must be summed across all antenna elements. The average must not include any intervals during which the transmitter is off or is transmitting at a reduced power level. If multiple modes of operation are possible (e.g., alternative modulation methods), the maximum conducted output power is the highest total transmit power occurring in any mode.

According to §15.247(b)(4), the conducted output power limit specified in paragraph(b) of this section is based on the use of antenna with directional gains that do not exceed 6 dBi. Except as shown in paragraph(c) of this section, if transmitting antenna of directional gain greater than 6 dBi are used, the conducted output power from the intentional radiator shall be reduced below the stated values in paragraph (b)(1), (b)(2), and (b)(3) of this section, as appropriate, by the amount in dB that the directional gain of the antenna exceeds 6dBi.

4.3. Test Procedure

- Peak and average power meter method.

All data rates and modes were investigated for this test. The full data for the worst case data rate are reported in this section.

The test follows section 8.1.3 & 8.2.3 of FCC KDB Publication 558074

-The maximum peak conducted output power can be measured using a broad band peak RF power meter. The power meter must have a video bandwidth that is greater than or equal to the DTS bandwidth and shall utilize a fast, average-responding diode type sensor.

-This procedure provides an alternative for determining the RMS output power using a broadband RF average power meter with a thermocouple detector if the EUT can be configured to transmit continuously or if the power meter can be triggered/signal-gated such that the power is measured only when the EUT is transmitting at its maximum power control level.

1. Place the EUT on the table and set it in the transmitting mode.
2. Remove the antenna from the EUT and then connect a low loss RF cable from the antenna port to the Power sensor. (S/W name : R&S Power Viewer, Version : 3.2.0)
3. Measure peak & average power each channel.

The results shown in this test report refer only to the sample(s) tested unless otherwise stated. This test report cannot be reproduced, except in full, without prior written permission of the Company.

4.4. Test Results

Ambient temperature : (24 ± 2) °C
 Relative humidity : 47 % R.H.

Mode	Channel	Channel Frequency (MHz)	Data Rate (Mbps)	Attenuator + Cable offset (dB)	Average power Result (dB m)	Peak Power Result (dB m)
DSSS (802.11b)	Low	2 412	1	10.01	<u>12.72</u>	<u>15.43</u>
			2		12.67	15.36
			5.5		12.65	15.38
			11		12.58	15.33
	Middle	2 437	1	10.02	<u>12.81</u>	<u>15.50</u>
			2		12.77	15.49
			5.5		12.75	15.46
			11		12.74	15.49
	High	2 462	1	10.04	<u>12.70</u>	<u>15.43</u>
			2		12.67	15.41
			5.5		12.66	15.40
			11		12.63	15.42
OFDM (802.11g)	Low	2 412	6	10.01	<u>10.91</u>	19.96
			9		10.88	19.98
			12		10.85	<u>20.29</u>
			18		10.78	19.53
			24		10.55	20.05
			36		10.42	19.92
			48		10.31	19.95
			54		10.16	20.01
	Middle	2 437	6	10.02	<u>11.34</u>	20.21
			9		11.33	20.18
			12		11.31	<u>20.55</u>
			18		11.25	19.99
			24		11.19	20.27
			36		11.03	20.15
			48		10.83	20.08
			54		10.78	20.51
	High	2 462	6	10.04	<u>11.26</u>	20.22
			9		11.24	20.23
			12		11.20	20.30
			18		11.14	20.11
			24		11.06	20.24
			36		10.95	20.01
			48		10.73	20.06
			54		10.63	<u>20.60</u>

The results shown in this test report refer only to the sample(s) tested unless otherwise stated. This test report cannot be reproduced, except in full, without prior written permission of the Company.

Mode	Channel	Channel Frequency (MHz)	Data rate (Mbps)	Attenuator + Cable offset (dB)	Average power Result (dB m)	Peak Power Result (dB m)
OFDM (802.11n_HT20)	Low	2 412	MCS0	10.01	<u>9.01</u>	18.60
			MCS1		8.86	18.44
			MCS2		8.80	18.46
			MCS3		8.71	18.18
			MCS4		8.66	18.53
			MCS5		8.60	18.64
			MCS6		8.54	<u>18.70</u>
			MCS7		8.51	18.62
	Middle	2 437	MCS0	10.02	<u>9.03</u>	18.58
			MCS1		8.90	18.48
			MCS2		8.85	18.47
			MCS3		8.70	18.30
			MCS4		8.69	18.60
			MCS5		8.54	18.70
			MCS6		8.50	<u>18.72</u>
			MCS7		8.42	18.50
	High	2 462	MCS0	10.04	<u>8.89</u>	18.57
			MCS1		8.77	18.41
			MCS2		8.74	18.45
			MCS3		8.46	18.47
			MCS4		8.40	18.60
			MCS5		8.36	18.24
			MCS6		8.30	18.55
			MCS7		8.27	<u>18.63</u>

The results shown in this test report refer only to the sample(s) tested unless otherwise stated. This test report cannot be reproduced, except in full, without prior written permission of the Company.

5. Power Spectral Density Measurement

5.1. Test Setup

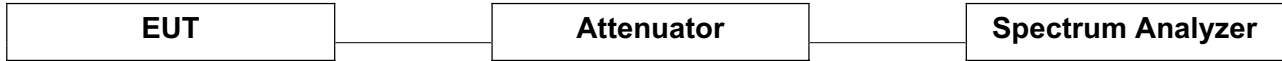

5.2. Limit

§15.247(e) For digitally modulated system, the power spectral density conducted from the intentional radiator to the antenna shall not be greater than 8 dB m in any 3 kHz band any time interval of continuous transmission. This power spectral density shall be determined in accordance with the provisions of paragraph (b) of this section. The same method of determining the conducted output power shall be used to determine the power spectral density.

5.3. Test Procedure

All data rates and modes were investigated for this test. The full data for the worst case data rate are reported in this section.

The measurements are recorded using the AVGPSD measurement procedure in section 9.2 of KDB 558074.

1. Use this procedure when the maximum conducted output power in the fundamental emission is used to demonstrate compliance. The EUT must be configured to transmit continuously at full power over the measurement duration.
2. Set the analyzer span to at least 1.5 times the DTS channel bandwidth.
3. Set the RBW ≥ 3 kHz
4. Set the VBW $\geq 3 \times$ RBW
5. Detector = power average (RMS) or sample detector (when RMS not available).
6. Ensure that the number of measurement points in the sweep $\geq 2 \times$ span/RBW
7. Sweep time = auto couple.
8. Employ trace averaging (RMS) mode over a minimum of 100 traces.
9. Use the peak marker function to determine the maximum amplitude level.

The results shown in this test report refer only to the sample(s) tested unless otherwise stated. This test report cannot be reproduced, except in full, without prior written permission of the Company.

5.4. Test Results

Ambient temperature : (24 ± 2) °C
 Relative humidity : 47 % R.H.

Operation Mode	Data Rate (Mbps)	Channel	Frequency	Measured PSD (dB m)	Maximum Limit (dB m)
DSSS (802.11b)	1	Low	2 412 MHz	-20.33	8
		Middle	2 437 MHz	-18.72	8
		High	2 462 MHz	-18.27	8
OFDM (802.11g)	6	Low	2 412 MHz	-23.76	8
		Middle	2 437 MHz	-23.16	8
		High	2 462 MHz	-22.54	8
OFDM (802.11n_HT20)	MCS0	Low	2 412 MHz	-25.32	8
		Middle	2 437 MHz	-24.64	8
		High	2 462 MHz	-24.97	8

The results shown in this test report refer only to the sample(s) tested unless otherwise stated. This test report cannot be reproduced, except in full, without prior written permission of the Company.

DSSS : 802.11b
Low Channel



Middle Channel

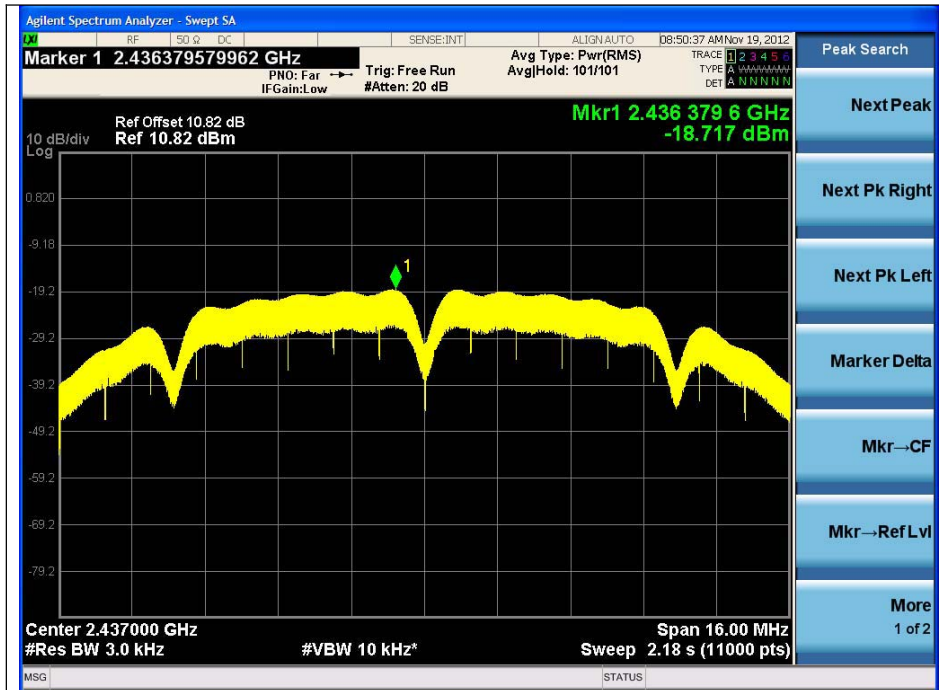

The results shown in this test report refer only to the sample(s) tested unless otherwise stated. This test report cannot be reproduced, except in full, without prior written permission of the Company.

High Channel

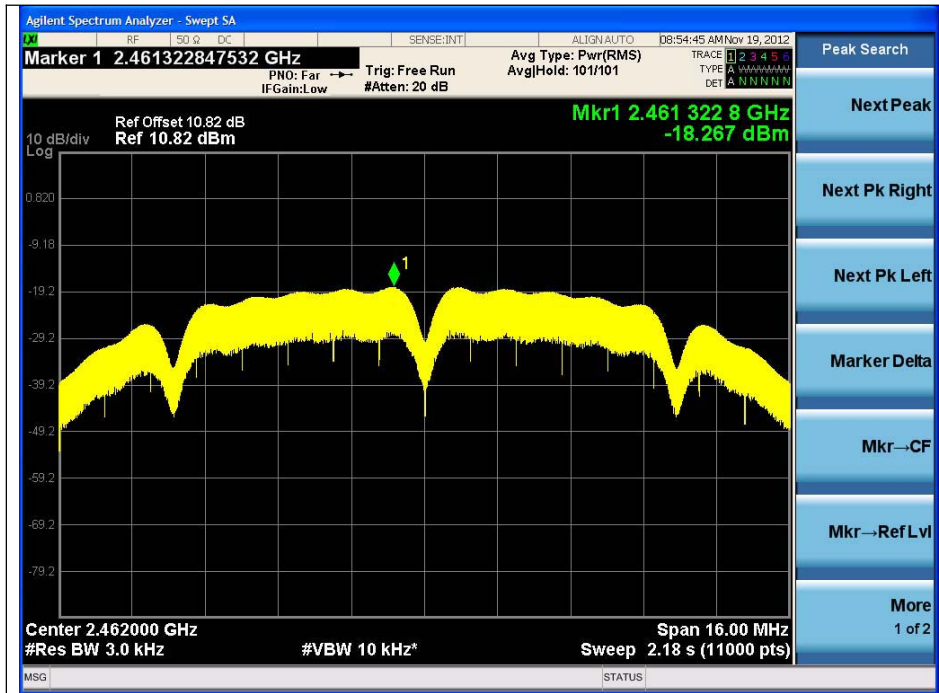

OFDM : 802.11g

Low Channel

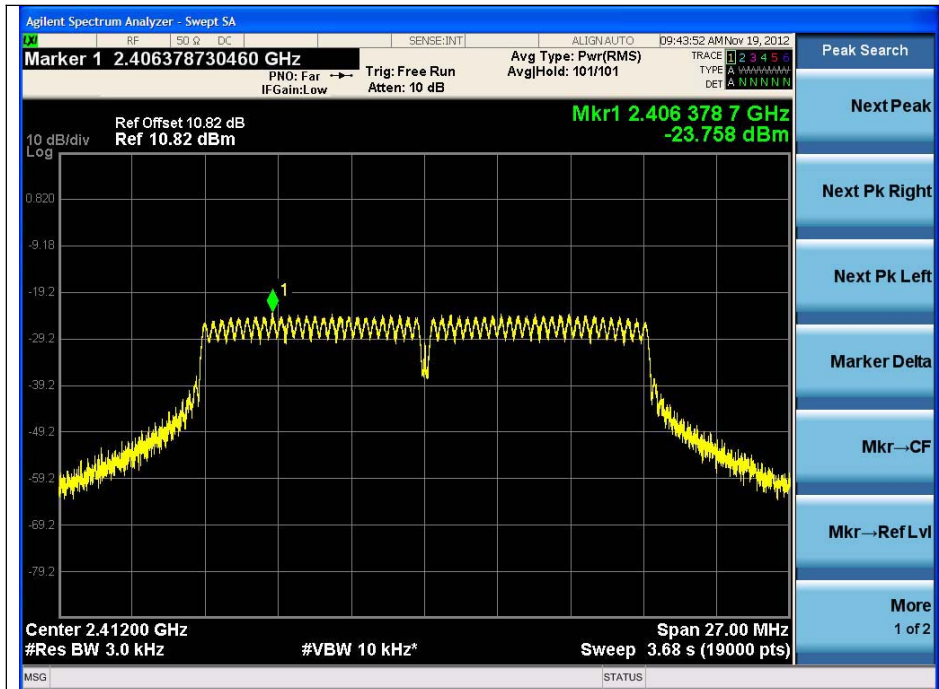

The results shown in this test report refer only to the sample(s) tested unless otherwise stated. This test report cannot be reproduced, except in full, without prior written permission of the Company.

Middle Channel

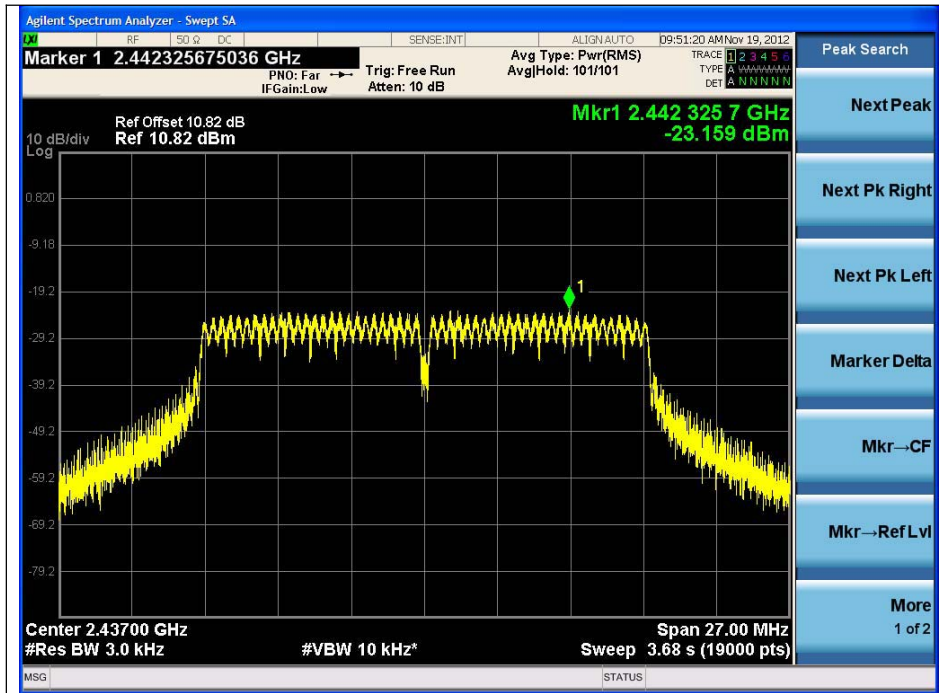

High Channel

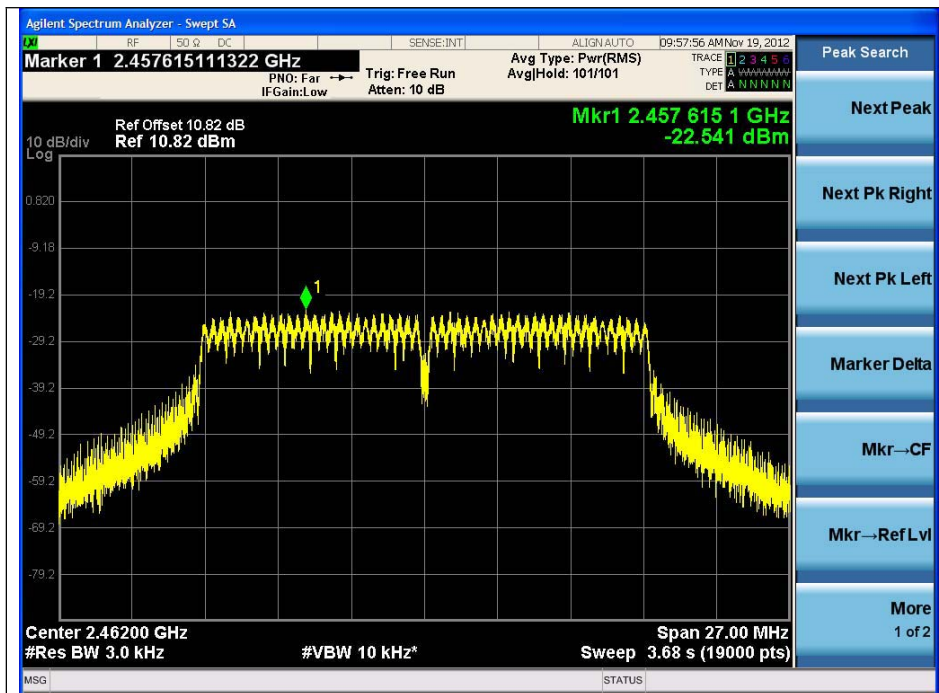

The results shown in this test report refer only to the sample(s) tested unless otherwise stated. This test report cannot be reproduced, except in full, without prior written permission of the Company.

OFDM : 802.11n_HT20
Low Channel

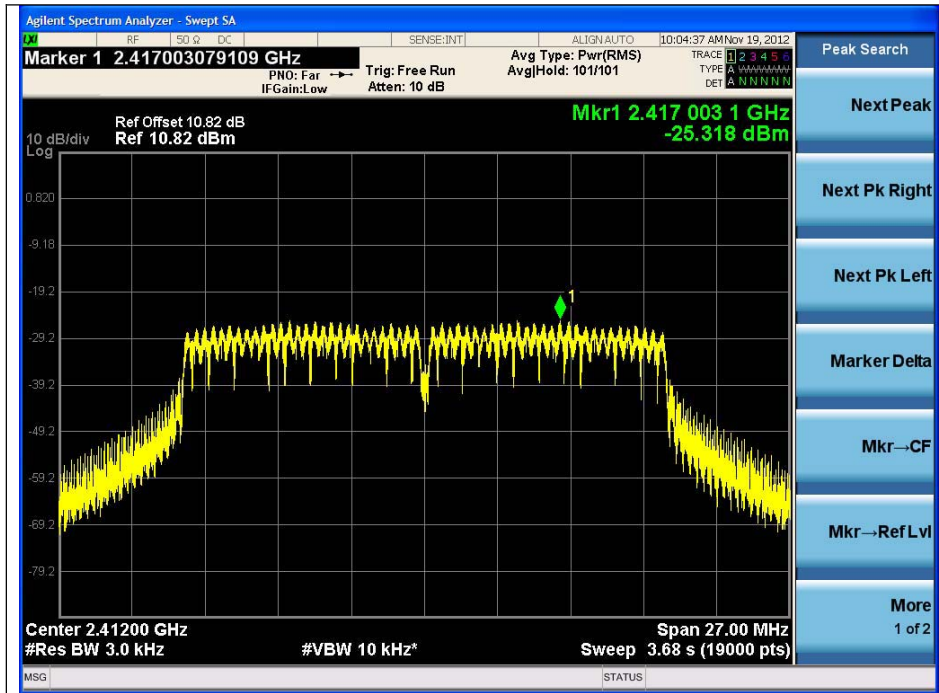

Middle Channel

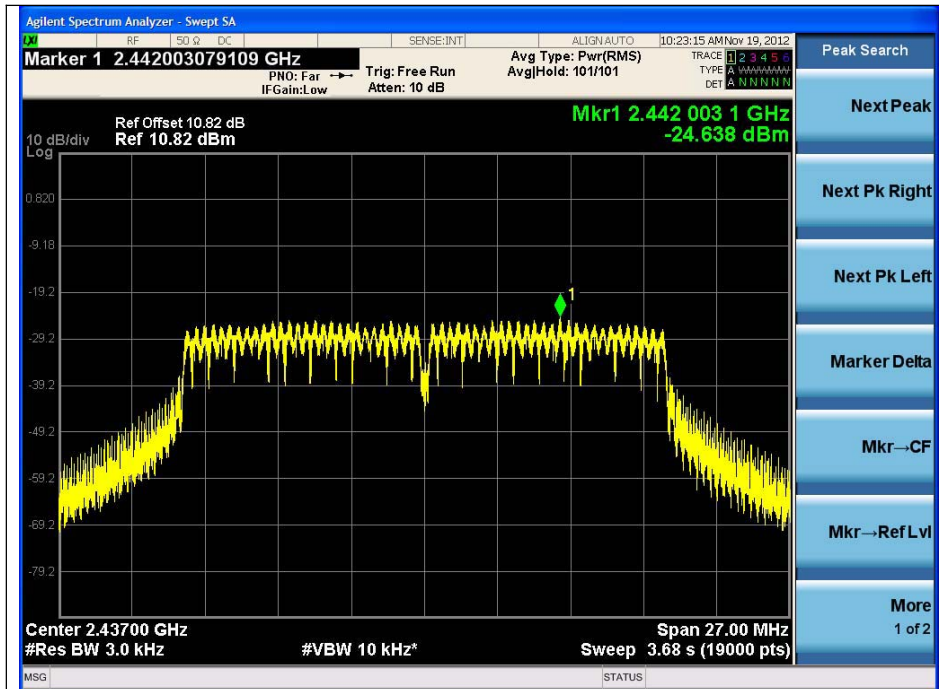

The results shown in this test report refer only to the sample(s) tested unless otherwise stated. This test report cannot be reproduced, except in full, without prior written permission of the Company.

High Channel

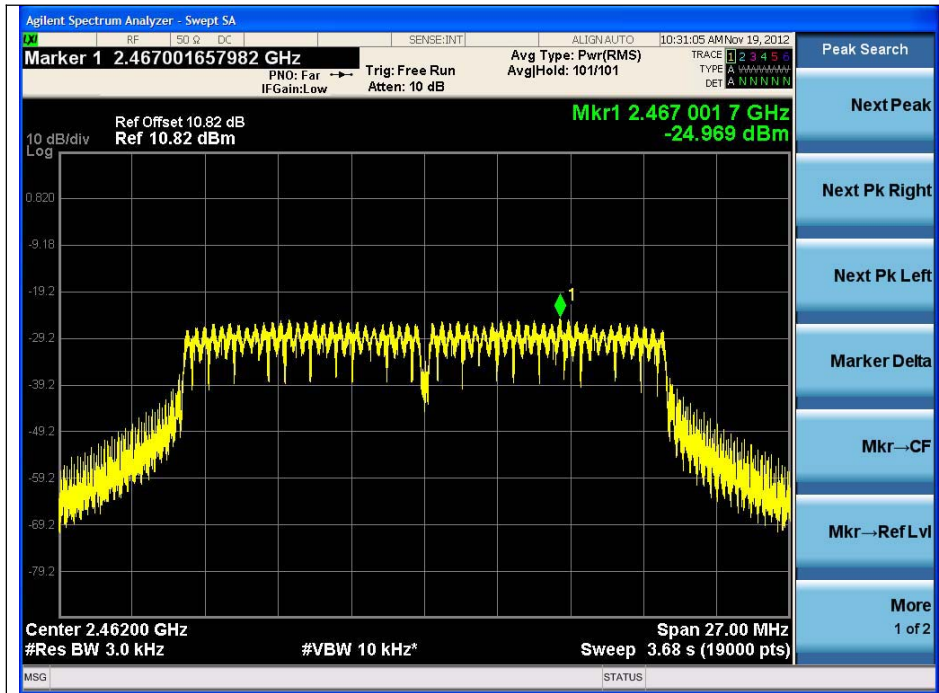

The results shown in this test report refer only to the sample(s) tested unless otherwise stated. This test report cannot be reproduced, except in full, without prior written permission of the Company.

6. Transmitter AC Power Line Conducted Emission

6.1. Test Setup

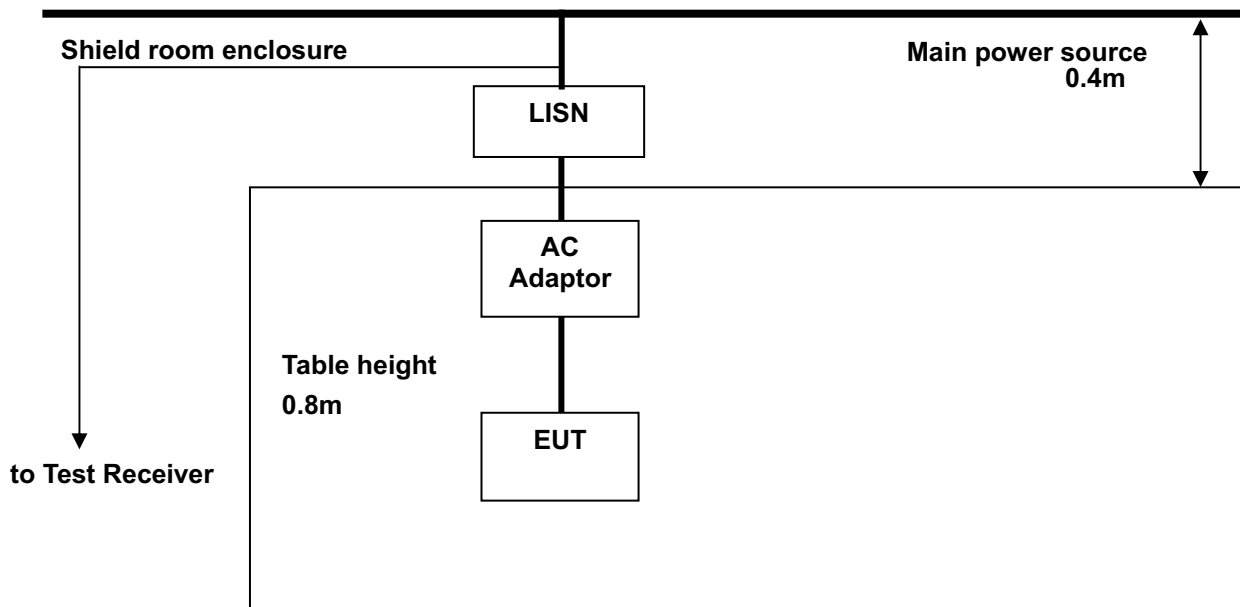

6.2. Limit

According to §15.207(a) for an intentional radiator that is designed to be connected to the public utility (AC) power line, the radio frequency voltage that is conducted back onto the AC power line on any frequency or frequencies, within the band 150 kHz to 30 MHz, shall not exceed the limits in the following table, as measured using a 50 uH/50 ohm line impedance stabilization network(LISN).

Compliance with the provision of this paragraph shall on the measurement of the radio frequency voltage between each power line and ground at the power terminal. The lower applies at the boundary between the frequency ranges.

Frequency of Emission (MHz)	Conducted limit (dB μ V)	
	Quasi-peak	Average
0.15 – 0.50	66 - 56*	56 - 46*
0.50 – 5.00	56	46
5.00 – 30.0	60	50

* Decreases with the logarithm of the frequency.

The results shown in this test report refer only to the sample(s) tested unless otherwise stated. This test report cannot be reproduced, except in full, without prior written permission of the Company.

6.3. Test Procedures

All data rates and modes were investigated for this test. The full data for the worst case data rate are reported in this section.

AC line conducted emissions from the EUT were measured according to the dictates of ANSI C63.4-2003

1. The test procedure is performed in a 6.5m × 3.6m × 3.6m (L × W × H) shielded room. The EUT along with its peripherals were placed on a 1.0 m(W) × 1.5 m(L) and 0.8 m in height wooden table and the EUT was adjusted to maintain a 0.4 meter space from a vertical reference plane.
2. The EUT was connected to power mains through a line impedance stabilization network (LISN) which provides 50 ohm coupling impedance for measuring instrument and the chassis ground was bounded to the horizontal ground plane of shielded room.
3. The excess power cable between the EUT and the LISN was bundled. All connecting cables of EUT were moved to find the maximum emission.

The results shown in this test report refer only to the sample(s) tested unless otherwise stated. This test report cannot be reproduced, except in full, without prior written permission of the Company.

6.4. Test Results (Worst case configuration_11g mode, 6 Mbps, high channel)

The following table shows the highest levels of conducted emissions on both phase of Hot and Neutral line.

Ambient temperature : (24 ± 2) °C
 Relative humidity : 47 % R.H.

Frequency range : 0.15 MHz – 30 MHz
 Measured Bandwidth : 9 kHz

FREQ. (MHz)	LEVEL(dB μ V)		LINE	LIMIT(dB μ V)		MARGIN(dB)	
	Q-Peak	Average		Q-Peak	Average	Q-Peak	Average
0.21	42.08	31.78	H	63.21	53.21	22.35	26.85
0.31	39.08	33.28	H	60.11	50.11	20.95	19.95
0.53	33.27	22.67	H	56.00	46.00	24.15	22.35
1.93	34.08	25.48	H	56.00	46.00	24.91	22.91
3.34	33.07	25.77	H	56.00	46.00	24.05	22.55
4.70	33.18	26.38	H	56.00	46.00	23.25	23.25
0.21	40.86	26.36	N	63.41	53.41	21.33	21.63
0.31	39.16	30.16	N	60.11	50.11	21.03	16.83
0.82	31.85	23.65	N	56.00	46.00	22.73	23.33
1.32	31.09	23.09	N	56.00	46.00	21.92	20.52
3.02	31.95	23.45	N	56.00	46.00	22.93	20.23
3.47	32.75	22.75	N	56.00	46.00	22.82	19.62

Note ;

1. Line (H): Hot, Line (N): Neutral
2. All modes of operation were investigated and the worst-case emissions are reported using 11n_HTXX MCSXX
3. The limit for Class B device(s) from 150 kHz to 30 MHz are specified in Section of the Title 47 CFR.
4. Traces shown in plot mad using a peak detector and average detector
5. Deviations to the Specifications: None.

The results shown in this test report refer only to the sample(s) tested unless otherwise stated. This test report cannot be reproduced, except in full, without prior written permission of the Company.

Plots of Conducted Power line

Test mode : (Hot)

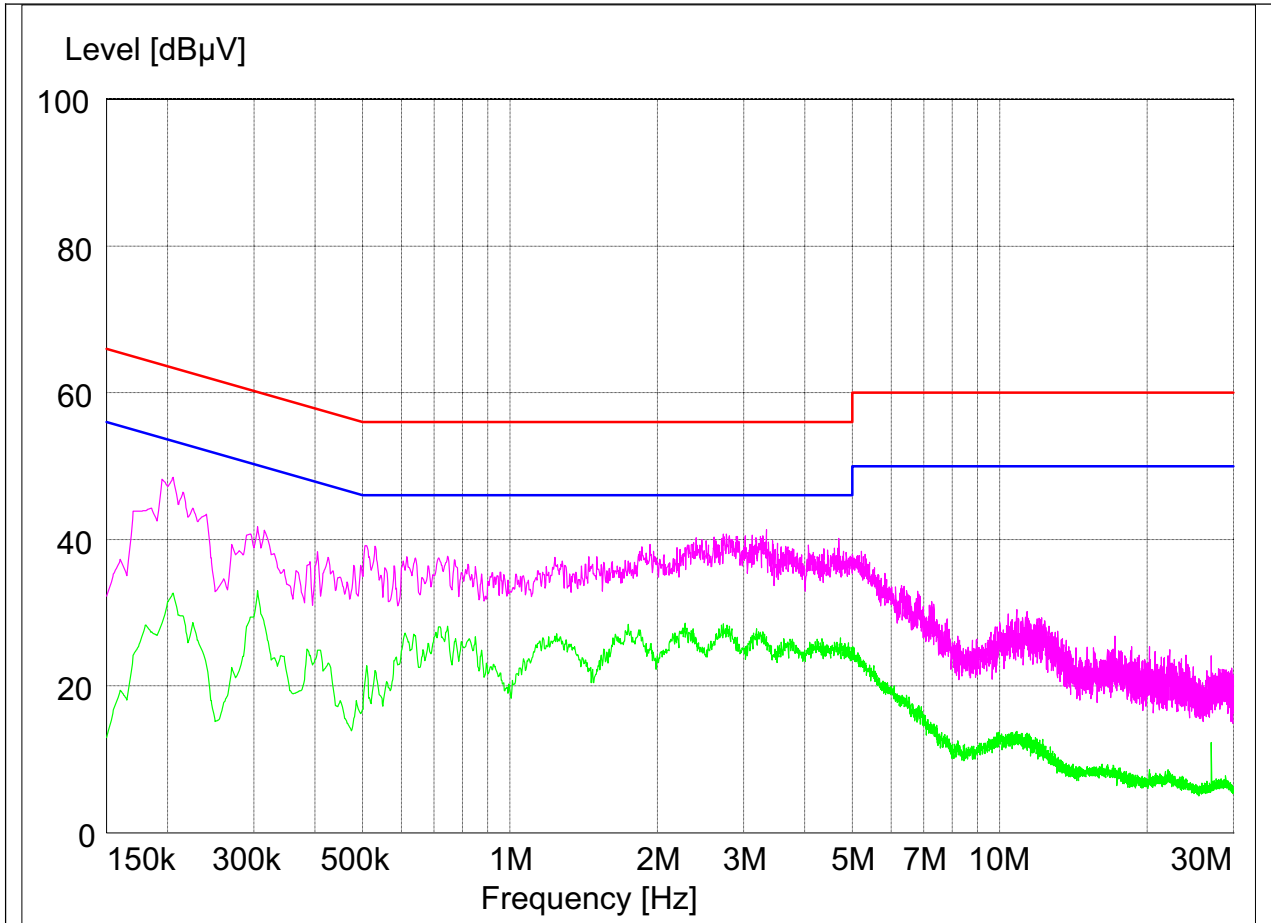

The results shown in this test report refer only to the sample(s) tested unless otherwise stated. This test report cannot be reproduced, except in full, without prior written permission of the Company.

Test mode : (Neutral)

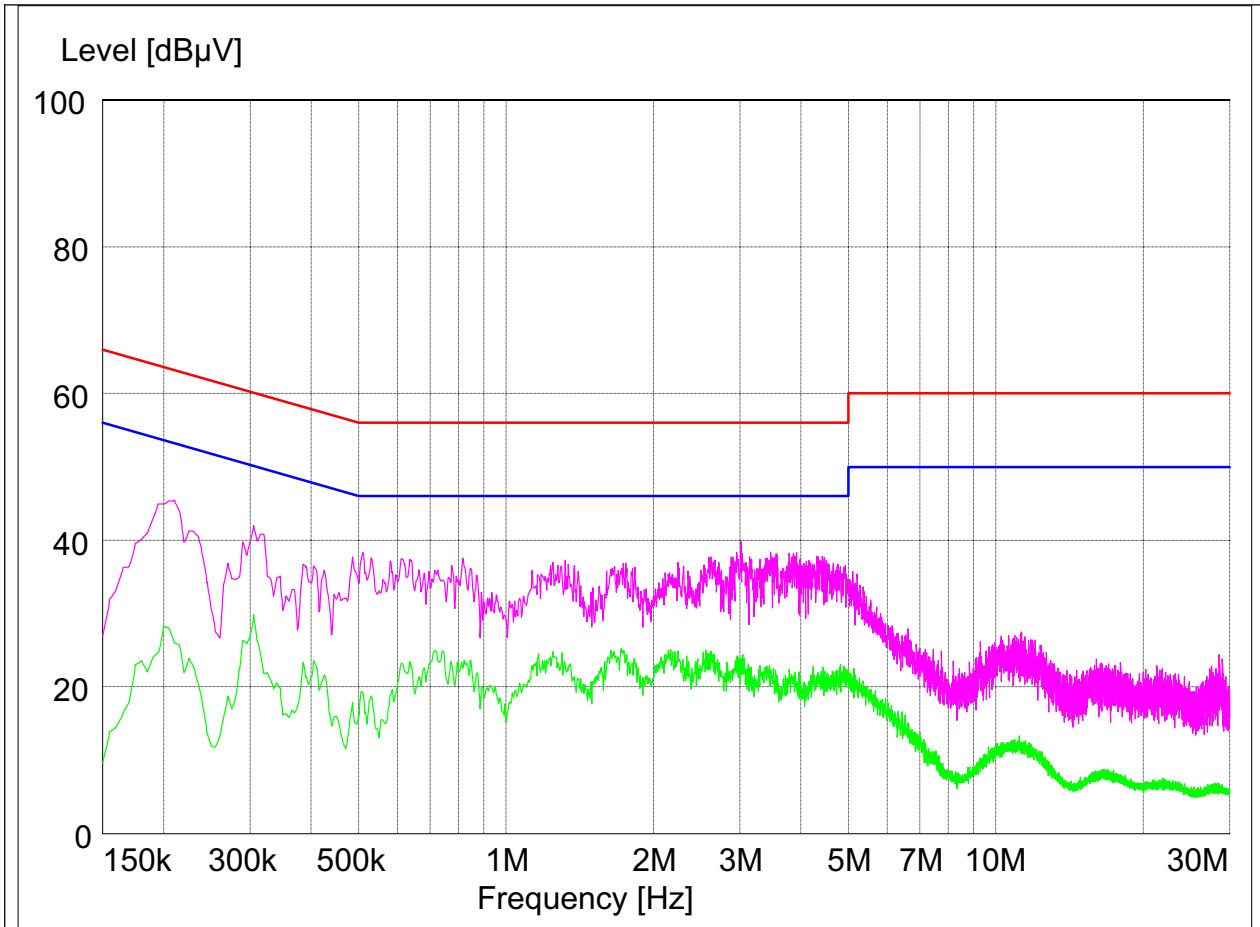

The results shown in this test report refer only to the sample(s) tested unless otherwise stated. This test report cannot be reproduced, except in full, without prior written permission of the Company.

7. Antenna Requirement

7.1. Standard Applicable

For intentional device, according to FCC 47 CFR Section §15.203, an intentional radiator shall be designed to ensure that no antenna other than that furnished by the responsible party shall be used with the device. And according to FCC 47 CFR Section §15.247 (b) if transmitting antennas of directional gain greater than 6 dB i are used, the power shall be reduced by the amount in dB that the gain of the antenna exceeds 6 dB i.

7.2. Antenna Connected Construction

Antenna used in this product is Internal type(FPCB antenna) with gain of -1.57 dB i.