

# FCC MEASUREMENT REPORT

## CERTIFICATION OF COMPLIANCE

### FCC Part 15 Certification Measurement

**PRODUCT** : DIRECTV DVR  
**MODEL/TYPE NO** : SIR-S4120R / SIR-S4080R / SIR-S4040R  
**FCC ID** : A3LDIRECTV  
**APPLICANT** : SAMSUNG ELECTRONICS Co., Ltd.  
**ADDRESS** : 3351 Michelson Drive, Suite 290 Irvine, CA 92162 United States  
**ADDRESS of Manuf.** : 416, Maetan-3 Dong, Paldal-Ku, Suwon City, Kyongki-Do,  
: Korea, 442-742  
**Atten.** : Kim, Jonguk / Technology Planning Group, Assistant Manager  
**FCC CLASSIFICATION** : Part 15 Class B Unintentional Radiators  
: TV Interface Devices, Including cable system terminal devices  
**FCC RULE PART(S)** : FCC Part 15 Subpart B  
**FCC PROCEDURE** : Certification (Class II Permissive Change)  
**TRADE NAME** : SAMSUNG  
**TEST REPORT No.** : E04.0521.FCC.274N  
**DATES OF TEST** : May 13~14, 2004  
**TEST LABORATORY** : ETL Inc ( FCC Registration Number : 95422)  
: #584 Sangwhal-ri, Yaju-kun, Kanam-myon, Kyounggi-do,  
: 469-885, Korea  
: Tel : (031) 885-0072 Fax : (031) 885-0074

This DIRECTV DVR, Model SIR-S4120R has been tested in accordance with the measurement procedures specified in ANSI C63.4-1992 at the ETL/EMC Test Laboratory and has been shown to be complied with the electromagnetic radiated emission limits specified in FCC Rule Part15 Subpart B : Unintentional Radiators TV Interface Devices. Including cable system terminal devices

I attest to the accuracy of data. All measurement herein were performed by me or were made under my supervision and are correct to the best of my knowledge and belief. I assume full responsibility for the completeness of these measurements and vouch for the qualifications of all persons taking them.

The results of testing in this report apply to the product/system which was tested only. Other similar equipment will not necessarily produce the same results due to production tolerance and measurement uncertainties .

*Yo Han, Park*

Yo Han, Park / Chief Engineer

**E-RAE Testing Laboratory Inc.**  
**#584 Sangwhal-ri, Yaju-kun, Kanam-myon,**  
**Kyonggi-do, 469-885, Korea**



---

## Table of Contents

### **ATTACHMENT A: COVER LETTER(S)**

#### **FCC Measurement Report**

- 1. Introduction**
- 2. Product Information**
- 3. Description of Tests**
- 4. Test Condition**
- 5. Test Results**
  - 5.1 Summary of Test Results**
  - 5.2 Conducted Emission Test**
  - 5.3 Radiated Emission Test**
  - 5.4 Output Signal Level Measurement**
  - 5.5 Output Terminal Conducted Spurious Emission Measurement**
  - 5.6 Transfer Switch Measurement**
- 6. Sample Calculations**
- 7. List of test Equipment used for Measurement**

#### **Appendix A. Test Setup Photographs**

#### **Appendix B. Internal Photographs**

#### **Appendix C. External Photographs**

**Scope** – Measurement and determination of electromagnetic emission(EME) of radio frequency devices including intentional radiators and/or unintentional radiators for compliance with the technical rules and regulations of the U.S Federal Communications Commission(FCC)

## General Information

**Applicant Name** : SAMSUNG ELECTRONICS Co.,Ltd.  
**Address** : 3351 Michelson Drive, Suite 290 Irvine, CA 92162 United States  
**Attention** : Kim, Jonguk / Technology Planning Group, Assistant Manager

- **EUT Type** : DIRECTV DVR
- **Model Number** : SIR-S4120R & SIR-S4080R & SIR-S4040R
- **FCC Identifier** : A3LDIRECTV
- **S/N** : N/A
- **Freq. Range** : 61.25MHz – 71.75MHz
- **FCC Rule Part(s)** : Part 15 Subpart B Section 15.115
- **Test Procedure** : ANSI C63.4-1992
- **FCC Classification** : TV Interface Device(HID)
- **RF Channels** : Ch. 3 / Ch. 4
- **Dates of Tests** : MAY 13~14, 2004
- **Place of Tests** : ETL Inc  
584, Sangwhal-Ri, Kanam-Myun, Yaju-Kun,  
Kyounggi-Do, Korea  
Tel : (031) 885-0072 Fax : (031) 885-0074
- **Test Report No.** : E02.1109.FCC.751N



# FCC TEST REPORT



## 1. INTRODUCTION

---

The measurement test for radiated and conducted emission test were conducted at the open area test site of E-RAE Testing Laboratory Inc. facility located at 584, Sangwhal-ri, Ganam-myun, Youju-kun, Kyoungki-do, Korea. The site is constructed in conformance with the requirements of the ANSI C63.4-1992 and CISPR Publication 16. The ETL has site descriptions on file with the FCC for 3 and 10 meter site configurations. Detailed description of test facility was found to be in compliance with the requirements of Section 2.948 FCC Rules according to the ANSI C63.4-1992 and registered to the Federal Communications Commission(Registration Number : 95422 ).

The measurement procedure described in American National Standard for Method of Measurement of Radio-Noise Emission from Low-Voltage Electrical and Electronic Equipment in the Range of 9kHz to 40GHz (ANSI C.63.4-1992) was used in determining radiated and conducted emissions from the Samsung Electronics Co.,Ltd. DIRECTV DVR, Model : SIR-S4120R & SIR-S4080R & SIR-S4040S.

*This report only responds to the tested sample and may not be reproduced, except in full, without written approval of the ETL, Inc.*

## 2. PRODUCT INFORMATION

---

### 2.1 Equipment Description

The Equipment Under Test(EUT) is Samsung Electronics Co.,Ltd. DIRECTV DVR Model : SIR-S4120R & SIR-S4080S & SIR-S4040S.

### 2.2 General Specification

Applicat	SAMSUNG ELECTRONICS Co., Ltd.	
Equipment Under Test	DIRECTV DVR	
Trade Name	SAMSUNG	
Model Number	SIR-S4120R	
Variant Model	SIR-S4080R, SIR-S4040R	
Type of RF Output Connector	Type " F" Connector 75 ohm (Unbalanced)	
FCC ID Number	A3LDIRECTV	
Operating (RF Modulator Frequency)	CH. 3	Visual Carrier 61.25MHz Aural Carrier 65.75MHz
	CH. 4	Visual Carrier 67.25MHz Aural Carrier 71.75MHz
Mains Input	AC 100 ~ 120V, 50/60Hz	
LNB Input	LNB Input 950 ~ 2150MHz (75 ohm Unbalanced)	

## 3. DESCRIPTION OF TESTS

---

### 3.1 AC Powerline Conducted Emissions Test

Conducted emissions measurements were made in accordance with section 11, "Measurement of Information Technology Equipment" of ANSI C63.4-1992. The measurement were performed over the frequency range of 0.15MHz to 30MHz using a 50 /50uH LISN as the input transducer to a Spectrum Analyzer or a Field Intensity Meter. The measurements were made with the detector set for "Peak" amplitude within an bandwidth of 10KHz or for "quasi-peak" within a bandwidth of 9KHz.

The line-conducted emission test is conducted inside a shielded anechoic chamber room with 1m x 1.5m x 0.8m wooden table which is placed 40cm away from the vertical wall and 1.5m away from the side wall of the chamber room. Two EMCO 3825/2 LISN are bonded to the shielded room. The EUT is powered from the EMCO LISN and the support equipment is powered from the another EMCO LISN. Power to the LISNs is filtered by a noise cut power line filters. All electrical cables are shielded by braided tinned steel tubing with inner  $\phi$  1.2cm. If the EUT is a DC-powered device, power will be derived from the source power supply it normally will be powered from and these supply lines will be connected to the EMCO LISN. All interconnecting cables more than 1m were shortened by non-inductive bundling (serpentine fashion) to a 1m length. Sufficient time for the EUT, support equipment, and test equipment was allowed in order for them to warm up to their normal operating condition. The RF output of the LISN was connected to the R3261A Spectrum Analyzer to determine the frequency producing the max. emission from the EUT. The frequency producing the max. level was reexamined using the detector function set to the CISPR Quasi-Peak mode by manual, after scanned by automatic Peak mode from 0.45 to 30MHz. The bandwidth of the Spectrum Analyzer was set to 9kHz. The EUT, support equipment, and interconnecting cables were arranged and manipulated to maximize each emission. Each emission was maximized by switching power lines, varying the mode of operation or resolution, clock or data exchange speed, if applicable, whichever determined the worst-case emission. Each emission reported was calibrated using self-calibrating mode.

Photographs of the worst-case emission can be seen in photographs of conducted emission test setup.

## 3. DESCRIPTION OF TESTS

---

### 3.2 Radiated Emissions Test

Preliminary measurements were made at indoors 3 meter semi EMC Anechoic Chamber using broadband antennas, broadband amplifier, and spectrum analyzer to determine the emission frequencies producing the maximum EME.

Appropriate precaution was taken to ensure that all emissions from the EUT were maximized and investigated. The system configuration, mode of operation, turntable azimuth with respect to the antenna were noted for each frequency found. The spectrum was scanned from 30 to 1000MHz using biconilog antenna and above 1000MHz, linearly polarized double ridge horn antennas were used. Above 1GHz, linearly polarized double ridge horn antennas were used. The measurements were performed with three frequencies which were selected as bottom, middle and top frequency in the operating band. Emission level from the EUT with various configurations were examined on the spectrum analyzer connected with the RF amplifier and plotted graphically.

Final measurements were made outdoors open site at 3-meter test range using biconilog antenna. The output from the antenna was connected, via a preselector or a preamplifier, to the input of the EMI Measuring Receiver and Spectrum analyzer (for above 1GHz). The detector function was set to the quasi-peak or peak mode as appropriate. The measurement bandwidth on the Field strength receiver was set to at least 120kHz (1MHz for measurement above 1GHz), with all post-detector filtering no less than 10 times the measurement bandwidth. Sufficient time for the EUT, support equipment, and test equipment was allowed in order for them to warm up to their normal operating condition.

Each frequency found during preliminary measurement was examined and investigated as the same set up and configuration which produced the maximum emission. The EUT, support equipment and interconnecting cables were configured to the set-up producing the maximum emission for the frequency and were placed on top of a 0.8-meter high non-metallic 1m x 1.5 meter table. The turntable containing the system was rotated and the antenna height was varied 1 to 4 meters and stopped at the azimuth or height producing the maximum emission.

Each emission was maximized by varying the mode of operating frequencies of the EUT. The worst case emissions are recorded in the data tables. If necessary, the radiated emission measurement could be performed at a closer distance to ensure higher accuracy and the results were extrapolated to the specified distance using an inverse linear distance extrapolation factor (20dB/decade) as per section 15.31(f).

Photographs of the worst-case emission test setup can be seen in Appendix B.

## 3. DESCRIPTION OF TESTS

---

### 3.3 Antenna-Conducted Power Measurements

Power on the receive antenna terminals was to be determined by measurement of the voltage present at these terminals. Antenna-conducted power measurements is performed with the EUT antenna terminals connected directly to a spectrum analyzer, if the antenna impedance matches the impedance of the measuring instrument. Otherwise, use an impedance-matching network to connect the measuring instrument to the antenna terminals of the EUT. Losses in decibels in any impedance-matching network used is added to the measured value in dB $\mu$ V.

With the EUT tuned to one of the frequency over which device operates , measure both the frequency and voltage present at the antenna input terminals over the frequency range specified in the individual equipment requirements. Repeat this measurement with the receiver tuned to another frequency until the number of frequencies specified have been successively measured. Power on the receive antenna terminals is the ratio of  $V^2/R$ , where  $V$  is the loss-corrected voltage measured at the antenna terminals, and  $R$  is the impedance of the measuring instrument.

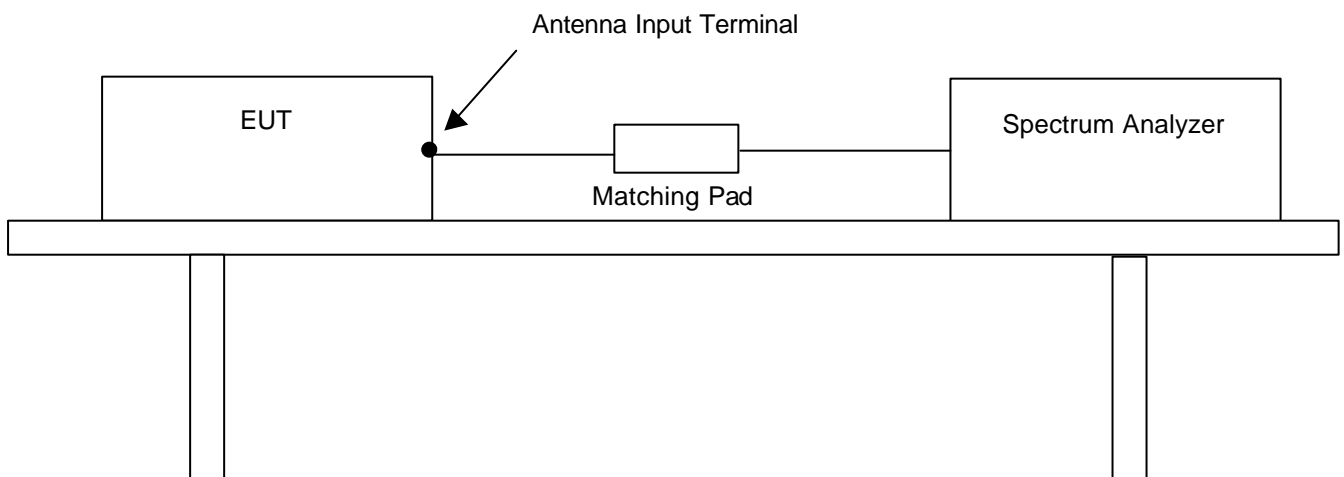

## 3. DESCRIPTION OF TESTS

---

### 3.4 Output Signal Conducted Level Measurement

The output signal level is the maximum voltage level present at the output terminals of the EUT on a particular frequency during normal use of the device.

The signal level was measured by direct connection to the spectrum analyzer with 50/75 ohm matching transformer between the spectrum analyzer and the TV interface device. The RF output signal level measured was the highest RF level present at the output terminals during normal use of the device. Measurements were made of the levels of both the visual (61.25 MHz) and audio (71.75 MHz) carrier for each TV channel (3 and 4) on which the device operates. The cable was supported between the EUT and the measuring instrument in a straight horizontal line so it had at least 75cm clearance from any conducting surface.

The EUT is provided with a typical signal consistent with normal operation. For each channel on which the EUT operates and in each mode in which the device operates, the video and audio carrier level is measured and recorded.

The voltage corresponding to the peak envelope power of the video modulated signal during maximum amplitude peaks across a resistance (R ohms) matching the rated output impedance of the device, must not exceed  $692.8 R^{1/2} \mu\text{V}$  for all other TV interface device. The voltage corresponding to peak envelope power of the audio modulated signal, if provided by the TV interface device, must not exceed  $155R^{1/2} \mu\text{V}$  for cable system terminal device of TV interface device used with a master antenna, and  $77.5 R^{1/2} \mu\text{V}$  for all other TV interface device. Losses in decibels in any impedance-matching network used is added to the measured value in dB $\mu\text{V}$ . The EUT was configured in accordance with ANSI C63.4-1992 Section 12.2 as below configuration block diagram and the EUT configuration can also be seen in Appendix B. Photographs of the test setup.

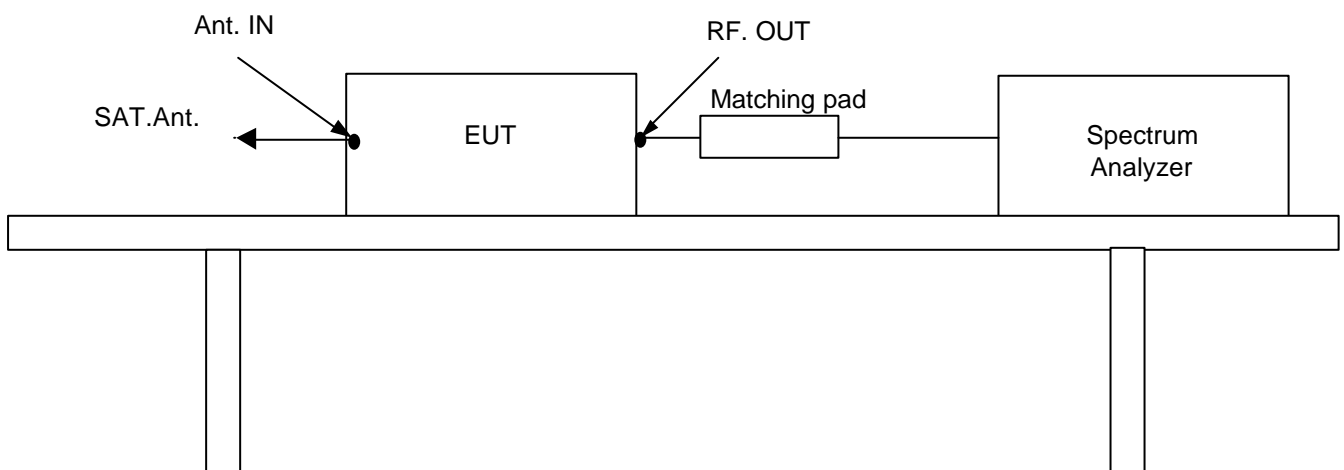

*This report only responds to the tested sample and may not be reproduced, except in full, without written approval of the ETL, Inc.*

## 3. DESCRIPTION OF TESTS

---

### 3.5 Output Terminal Conducted Spurious Emission Measurement

The RF output signal was fed to the TV receiver via coaxial cable. Measurements were made by direct connection to the spectrum analyzer and TV interface device with 50/75 ohm matching transformer. The frequency range 30 to 1000 MHz was investigated for significant emission.

The maximum RMS voltage of any emission appearing on frequencies removed by more than 4.6 MHz below and 7.4 MHz above the video carrier frequency on which the TV interface device is operated must not exceed  $692.8 R^{1/2} \mu\text{V}$  for cable system terminal device or TV interface device used with a master antenna and  $10.95 R^{1/2} \mu\text{V}$  for all other TV interface device when terminated with a resistance (R ohms) matching the rated output impedance of the TV interface device. The EUT was configured in accordance with ANSI C63.4-1992 Section 12.2 as below configuration block diagram and the EUT configuration can also be seen in Appendix B. Photographs of the test setup.

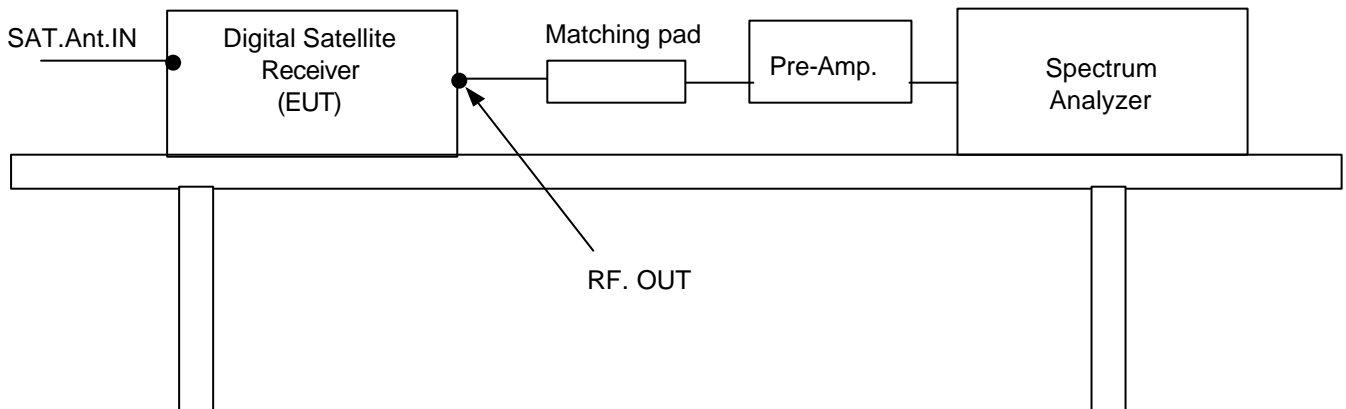

## 3. DESCRIPTION OF TESTS

---

### 3.6 Antenna Transfer Switch Measurement

Isolation was measured for all positions of an antenna transfer switch on all output channels of the EUT. TV interface device transfer switch isolation is the difference the levels of a signal going into one antenna input port of the switch and that of the same signal coming out of another antenna terminal of transfer switch. The isolation of an antenna transfer switch equipped with coaxial connectors is performed by measuring the maximum voltage of the visual carrier. Measurements were made of the maximum RMS voltage at the antenna input terminals of the switch for all positions of the transfer switch. The maximum voltage corresponds to the peak envelope power of the video signal during maximum amplitude peaks. In either position of the receiver transfer switch, the maximum voltage at the receiving antenna input terminals of the switch when terminated with a resistance (R ohms) matching the rated impedance of the antenna input of the switch, must not exceed  $0.346 R^{1/2} \mu V$ .

The maximum voltage corresponds to the peak envelope power of the video modulated signal during maximum amplitude.

The EUT was configured in accordance with ANSI C63.4-1992 Section 12.2 as below configuration block diagram. and the EUT configuration can also be seen in Appendix B. Photographs of the test setup.

The unused RF input/output terminals are terminated in a proper impedance. The antenna input terminal is connected to the the input of preamplifier through the matching transformer coaxial cable. And the output of preamplifier is connected to the spectrum analyzer. Then, the signal level on the antenna input terminal is measured under the EUT condition produced the maximum signal level.

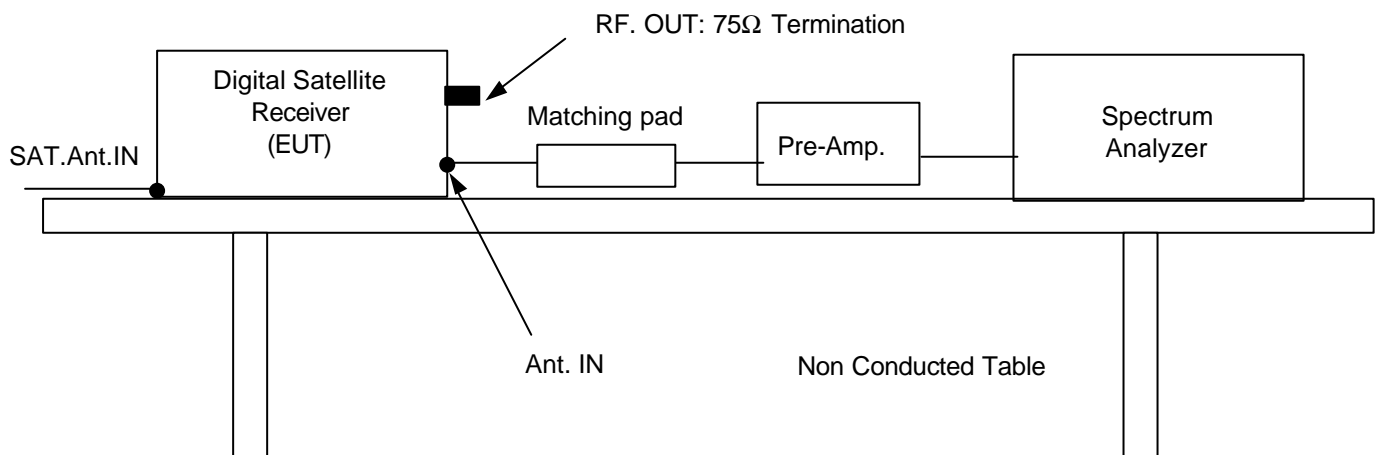

## 4. TEST CONDITION

---

### 4.1 Test Configuration

The device was configured for testing in a typical fashion (as a customer would normally use it). During the tests, the EUT and the supported equipments were installed to meet FCC requirement and operated in a manner which tends to maximize its emission level in a typical application.

### 4.2 EUT operation

The EUT was set to the normal receiving mode in a TV mode during all the testing in a manner similar to a typical use. For the EUT operation

### 4.3 Support Equipment Used

Following peripheral devices and interface cables were connected during the measurement:

#### EUT- Remote Control Cable TV Converter

FCC ID	: A3ISIR-S4120R
Model Name	: SIR-S4120R & SIR-S4080R & SIR-S4040R
Serial No.	: N/A
Manufacturer	: Samsung Electronics Co.,Ltd.
Power Supply Type	: Switching
Power Cord	: Non-Shielded, Detachable, 1.5m
Data Cable	: 1.5 m Shielded RF coaxial cable 1.5m Unshielded A/V RCA cable 1m Shielded RF coaxial cable to antenna

#### Support Unit 1 – TV

FCC ID	: N/A
Model Name	: DTQ-2002
Serial No.	: 909ZC00108
Manufacturer	: DAEWOO Electronics
Power Supply Type	: Switching
Power Cord	: Non-Shielded, Detachable, 1.2m
Data Cable	: refer to EUT connection

#### Support Unit 2 – Settop Box

FCC ID	: N/A
Model Name	: SK-011T
Serial No.	: 11AA500030
Manufacturer	: LG Electronics
Power Supply Type	: Switching
Power Cord	: Non-Shielded, Un-Detachable, 1.2m
Data Cable	: refer to EUT connection

*This report only responds to the tested sample and may not be reproduced, except in full, without written approval of the ETL, Inc.*

## 5. TEST RESULTS

---

### 5.1 Summary of Test Results

The measurement results were obtained with the EUT tested in the conditions described in this report. Detailed measurement data and plots showing the maximum emission of the EUT are reported.

FCC Rule Parts	Measurement Required	Result (Margin)
15.107	Conducted Emission	Passed by 17.5 dB
15.109	Radiated Emission	Passed by 3.3 dB
15.111	Antenna Power Conduction Measurement	Passed by 7.92 dB
15.115(b)(1)(ii)	Output Signal Level Measurement	Passed by 4.79 dB
15.115(b)(2)(ii)	Output Terminal Conducted Spurious Emission Measurement	Passed by 15.86 dB
15.115(c)(1)(ii)	Transfer Switch Measurement	No signal detected

The data collected shows that the **Samsung Electronics Co.,Ltd. DIRECTV DVR Model : SIR-S4120R & SIR-S4080R & SIR-S4040R.** complies with Part 15 Subpart B Unintentional radiators and the TV Interface Device section(15.115) of the FCC Rules.

The equipment is not modified anything, mechanical or circuits to improve EMI status during a measurement. No EMI suppression device(s) was added and/or modified during testing.

## 5. TEST RESULTS

### 5.2 Conducted Emission Test

EUT	DIRECTV DVR / SIR-S4120R, SIR-S4080R, SIR-S4040R
Limit apply to	FCC Part15 Subpart B Section 15.107
Test Date	May 13, 2004
Operating Condition	HDD Play + Time Shift Recording with TV Mode (CH. 3 & Ch. 4)
Environment Condition	Humidity Level : 45%RH, Temperature : 21
Result	Passed by 17.5 dB

### Conducted Emission Test Data

The following table shows the highest levels of conducted emissions on both polarization of live and neutral line.

Detector mode : CISPR Quasi-Peak mode ( 6dB Bandwidth : 9 kHz )

Frequency [MHz]	Reading [dB $\mu$ V]		Phase (*L/**N)	Limit [dB $\mu$ V]		Margin [dB]	
	Quasi-peak	Average		Quasi-peak	Average	Q.Peak	Average
0.150 (o)	47.6	30.6	H	66.0	56.0-	18.4	25.4
0.200 (f)	46.5	32.1	H	63.6	53.6	17.1	21.5
2.580 (o)	31.4	28.5	H	56.0	46.0	24.6	17.5
2.727 (o)	33.0	30.5	N	56.0	46.0	23.0	15.5
4.438 (f)	40.1	24.2-	N	56.0	56.0	15.9	21.8
All other frequencies are has 15dB margine at least							

#### NOTES :

1. \*H : Live Line , \*\*N :Neutral Line, (o) : Orientech SMPS, (f) : Feelux SMPS.
2. Margin value = Limit - Reading Level.
3. Channel was investigated for the worst case operation mode
4. Two SMPS were tested and highest values are reported, more detail result are refer to attached graph.

*H. J. Kim*

Test Engineer : H.J. Kim

## 5. TEST RESULTS (FeeLux SMPS : FDS-1001)

### Line: Hot Line (CH. 3)

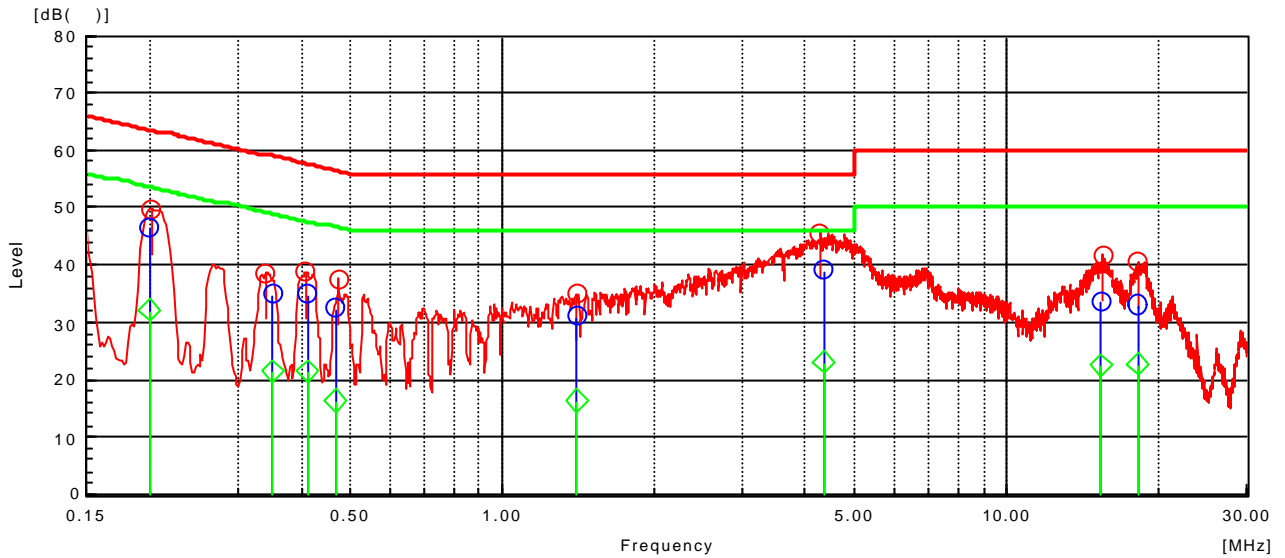

### Line: Neutral Line (CH. 3)

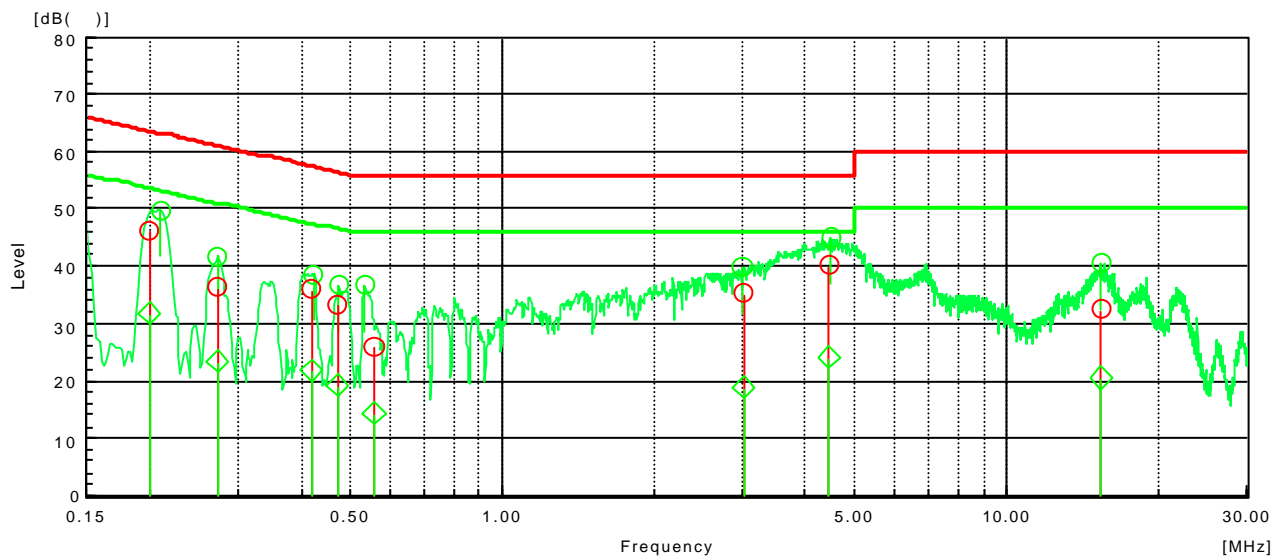

This report only responds to the tested sample and may not be reproduced, except in full, without written approval of the ETL, Inc.

## 5. TEST RESULTS (Feelux SMPS : FDS-1001)

### Line: Hot Line (CH. 4)

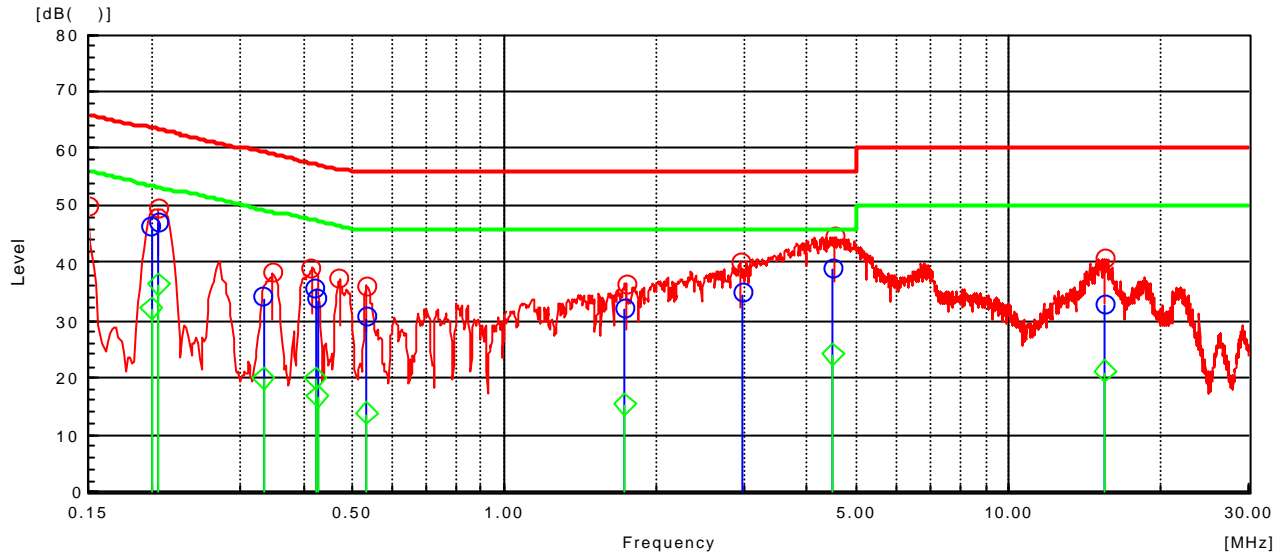

### Line: Neutral Line (CH. 4)

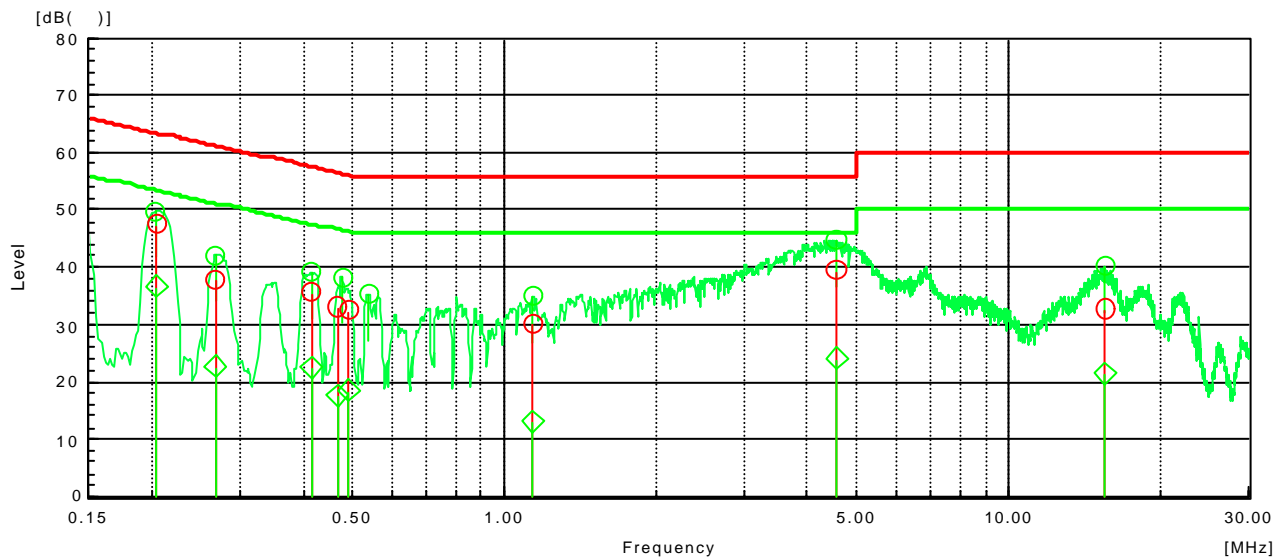

*This report only responds to the tested sample and may not be reproduced, except in full, without written approval of the ETL, Inc.*

## 5. TEST RESULTS (Orientech SMPS : ORTP-929)

### Line: Hot Line (CH. 3)

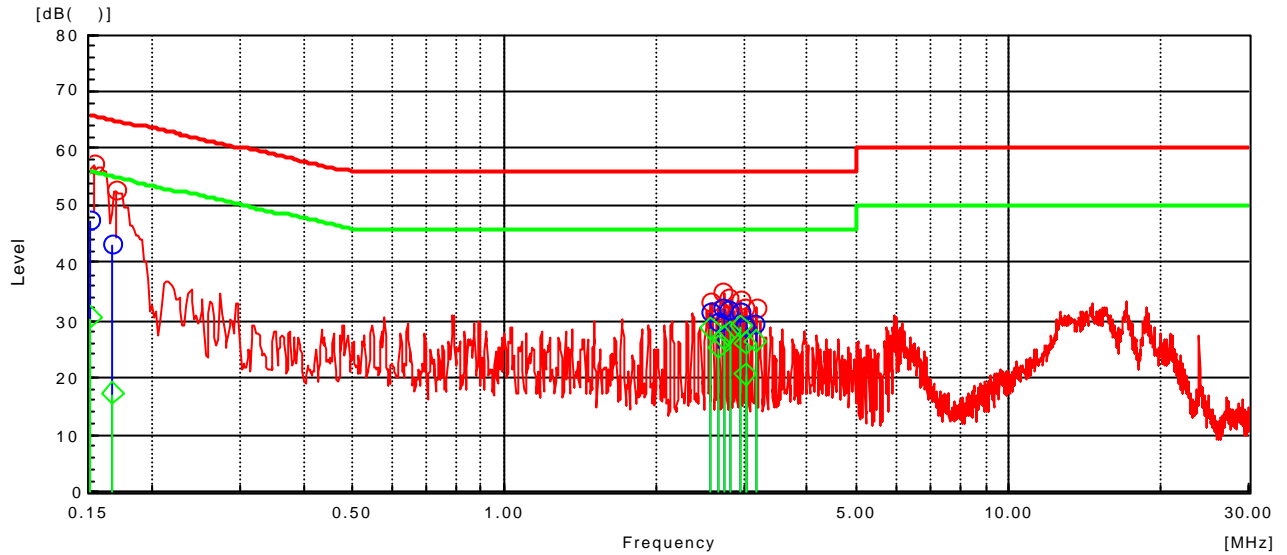

### Line: Neutral Line (CH. 3)

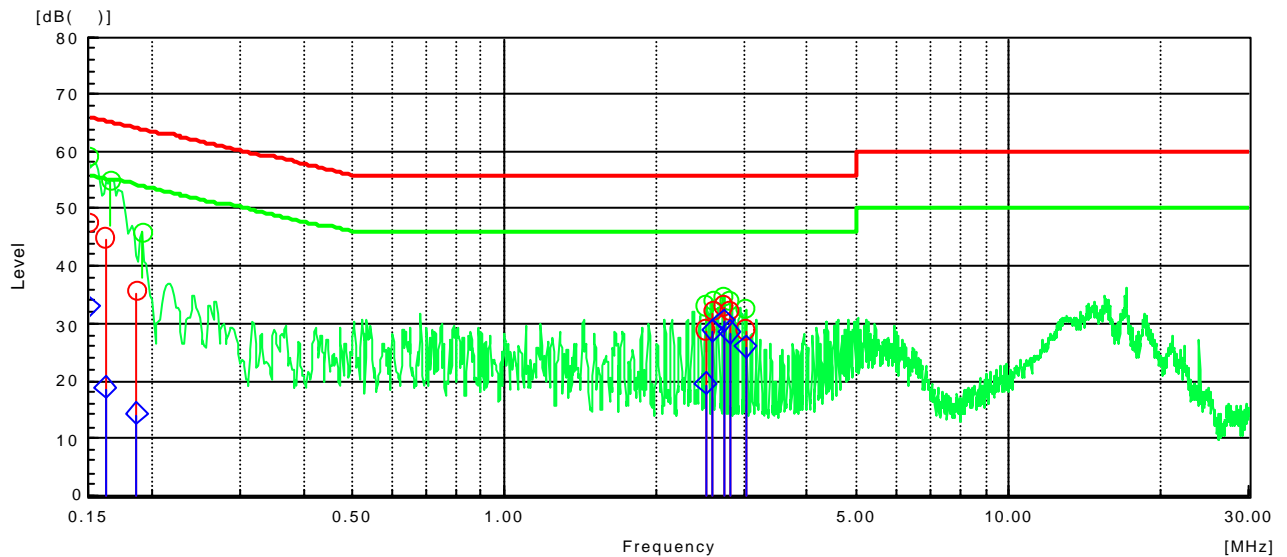

*This report only responds to the tested sample and may not be reproduced, except in full, without written approval of the ETL, Inc.*

## 5. TEST RESULTS (Orientech SMPS : ORTP-929)

### Line: Hot Line (CH. 4)

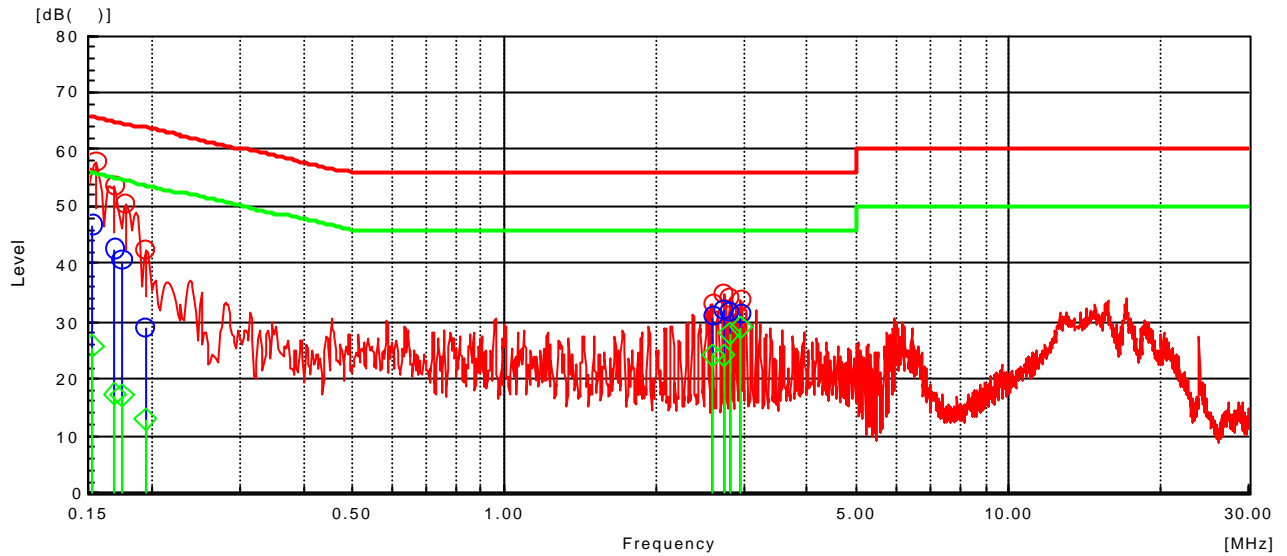

### Line: Neutral Line (CH. 4)

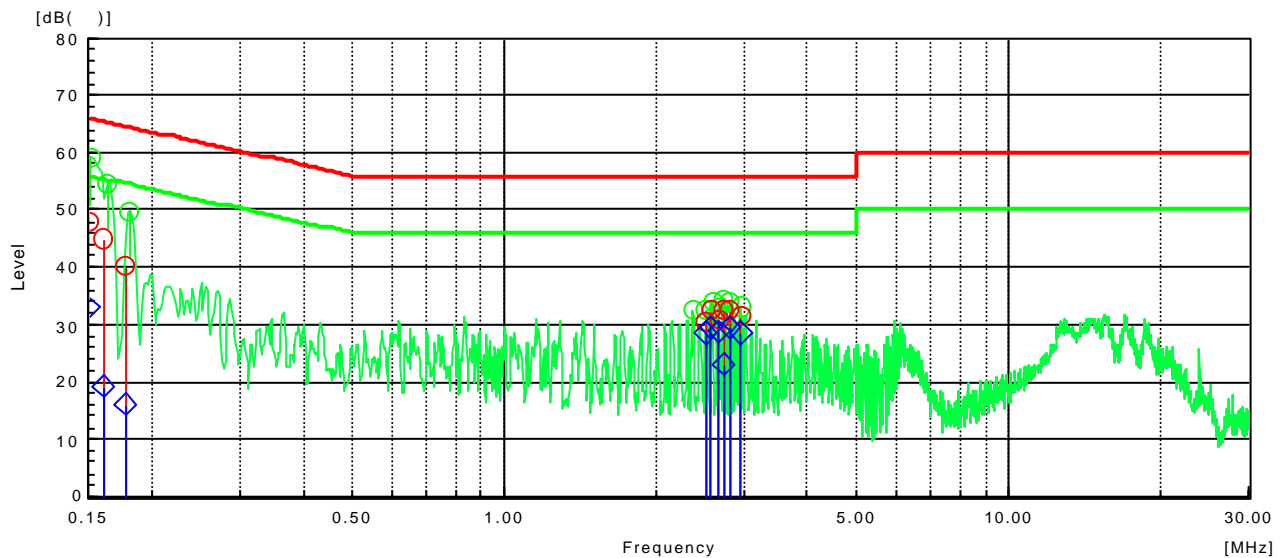

This report only responds to the tested sample and may not be reproduced, except in full, without written approval of the ETL, Inc.

## 5. TEST RESULTS

### 5.3 Radiated Emission Test

EUT	DIRECTV DVR / SIR-S4120R, SIR-S4080R, SIR-S4040R
Limit apply to	FCC Part15 Subpart B Section 15.109
Test Date	May 13, 2004
Operating Condition	HDD Play + Time Shift Recording with TV Mode (CH. 3 & Ch. 4) and Orientech SMPS : ORTP-929
Environment Condition	Humidity Level : 45%RH, Temperature : 21
Result	Passed by 3.3dB

### Radiated Emission Test Data

The following table shows the highest levels of radiated emissions on both polarization of horizontal and vertical.

Detector mode : CISPR Quasi-Peak mode ( 6dB Bandwidth : 120 kHz )

Measurement Distance : 3 meters

Freq. [MHz]	Reading [dB $\mu$ V]	Polarization (*H/**V)	Ant. Factor [dB]	Cable Loss [dB]	Emission Level [dB $\mu$ V/m]	Limit [dB $\mu$ V/m]	Margin [dB]
30.70	22.14	V	12.02	2.54	36.7	40.0	3.3
533.3	10.81	V	19.03	8.67	38.5	46.0	7.5
648.2	11.03	H	19.5	10.27	40.8	46.0	5.2
754.2	6.01	H	23.08	10.71	39.8	46.0	6.2
787.8	5.79	V	22.84	10.78	39.4	46.0	6.6
833.7	5.55	V	22.68	11.27	39.5	46.0	6.5
851.5	5.81	V	22.69	11.51	40.0	46.0	6.0

NOTES :

1. \* H : Horizontal polarization , \*\* V : Vertical polarization
2. Emission Level = Reading + Antenna factor + Cable loss
3. Margin value = Limit - Emission Level
4. All other emissions not reported frequencies were more than 7.5dB below the permitted limit.
5. Channel 3,4 were investigated for the worst case operation mode.

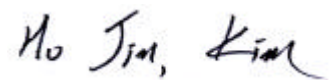

Test Engineer : H.J. Kim

This report only responds to the tested sample and may not be reproduced, except in full, without written approval of the ETL, Inc.

## 5. TEST RESULTS

### 5.3 Radiated Emission Test

EUT	DIRECTV DVR / SIR-S4120R, SIR-S4080R, SIR-S4040R
Limit apply to	FCC Part15 Subpart B Section 15.109
Test Date	May 13, 2004
Operating Condition	HDD Play + Time Shift Recording with TV Mode (CH. 3 & CH. 4) and Feelux SMPS : FDS-1001
Environment Condition	Humidity Level : 45%RH, Temperature : 21
Result	Passed by 4.2dB

### Radiated Emission Test Data

The following table shows the highest levels of radiated emissions on both polarization of horizontal and vertical.

Detector mode : CISPR Quasi-Peak mode ( 6dB Bandwidth : 120 kHz )

Measurement Distance : 3 meters

Freq. [MHz]	Reading [dB $\mu V$ ]	Polarization (*H/**V)	Ant. Factor [dB]	Cable Loss [dB]	Emission Level [dB $\mu V/m$ ]	Limit [dB $\mu V/m$ ]	Margin [dB]
124.5	20.06	H	12.19	3.85	36.0	43.5	7.4
133.3	22.06	V	12.77	3.93	39.3	43.5	4.2
534.5	12.5	H	19.02	8.68	40.2	46.0	5.8
667.5	8.26	V	20.54	10.30	39.1	46.0	6.9
851.3	4.91	V	22.68	11.51	39.1	46.0	6.9
648.3	11.43	V	19.50	10.27	41.2	46.0	4.8

NOTES :

1. \*H : Horizontal polarization , \*\*V : Vertical polarization
2. Emission Level = Reading + Antenna factor + Cable loss
3. Margin value = Limit - Emission Level
4. All other emissions not reported frequencies were more than 7.4dB below the permitted limit.
5. Channel 3,4 were investigated for the worst case operation mode.

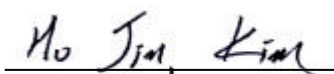
  
 Test Engineer : H.J. Kim

## 5. TEST RESULTS

---

### Radiated Emission(Harmonics) Test Data

This is the additional radiatd emission test due to the local oscillator of the satellite receiver part in the EUT.  
The fundamental and 2<sup>nd</sup> harmonic frequencies of the local oscillator of the satellite receiver part was tested on a near top, middle and bottom tuning frequencies of the EUT according to section 15.31(m) and 15.33(b)(3).

Freq. Tuned (MHz)	Reading (dBuV)	Ant.Pol (H/V)	Ant. Factor (dBuV/m)	Cable Loss (dB)	Result (dBuV/m)	Limit (dBuV/m)	Margin (dB)
950	-	H	-	-	-	54.0	-
955	-	H	-	-	-	54.0	-
960	-	H	-	-	-	54.0	-

\* Harmonics RF Radiation (Second Harmonics)

Freq. Tuned (MHz)	Reading (dBuV)	Ant.Pol (H/V)	Ant. Factor (dBuV/m)	Cable Loss (dB)	Result (dBuV/m)	Limit (dBuV/m)	Margin (dB)
950	-	H	-	-	-	54.0	-
955	-	H	-	-	-	54.0	-
960	-	H	-	-	-	54.0	-

Remark : There was no found any emission during the above test  
IF = N/A

## 5. TEST RESULTS

---

### 5.4 Antenna Power Conduction Measurement

EUT	DIRECTV DVR / SIR-S4120R, SIR-S4080R, SIR-S4040R
Limit apply to	FCC Part15 Subpart B Section 15.111
Test Date	May 14, 2004
Operating Condition	HDD Play + Time Shift Recording with TV Mode (CH. 3 & CH. 4)
Environment Condition	Humidity Level : 36%RH, Temperature : 20
Result	Passed by 7.92dB

#### Antenna Power Conduction Test Data

Antenna No.	Measured Freq. [MHz]	Meter Reading [dB $\mu$ V]	Correction Factor [dB]	Emission Level [dB $\mu$ V]	Limit [dB $\mu$ V]	Margin [dB]
Ant. 1	198.8	30.59	7.5	38.09	50.0	11.91
Ant. 2	179.2	34.58	7.5	42.08	50.0	7.92

NOTES :

1. No values higher than 8dB below the limit was measured during the Antenna power conduction Test.
2. Emission Level = Meter Reading + Correction Factor(Matching Loss + Cable loss)  
Margin value = Limit - Emission Level
3. Measurements using the CISPR Quasi-peak mode. The limits is 2.0 nanowatts in the frequency range 30 to 960MHz.

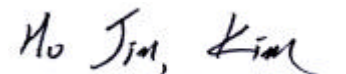

Test Engineer : H.J. Kim

## 5. TEST RESULTS

### 5.5 Output Signal Level Measurement

EUT	DIRECTV DVR / SIR-S4120R, SIR-S4080R, SIR-S4040R
Limit apply to	FCC Part15 Subpart B Section 15.115(b)(1)
Test Date	May 14, 2004
Operating Condition	HDD Play + Time Shift Recording with TV Mode (CH. 3 & CH. 4)
Environment Condition	Humidity Level : 36%RH, Temperature : 20
Result	Passed by 4.18dB

#### Test Data Table

The following table shows the highest levels of radiated emissions on both polarization of horizontal and vertical.

Detector mode : CISPR Quasi-Peak mode ( 6dB Bandwidth : 120 kHz )

Test Channel	Emission Frequency [MHz]	Meter Reading [dB $\mu$ V]	Correction Factor [dB]	Signal Level [dB $\mu$ V]	Limit [dB $\mu$ V]	Margin [dB]
3	61.25	57.21	7.5	64.71	69.5	4.79
	65.75	42.62	7.5	50.12	56.5	6.38
4	67.25	57.82	7.5	65.32	69.5	4.18
	71.75	41.80	7.5	49.30	56.5	7.20

#### NOTES :

1. *The correction factor consist of the insertion loss of the impedance matching transformer and the coaxial cable used for the test.*
2. *The spectrum was checked in each test mode and operation mode, and the maximum measured data were reported.*
3. *Signal Level = Meter Reading + Correction Factor(Matching Loss)  
Margin value = Limit - Signal Level*

*H.J. Kim*

Test Engineer : H.J. Kim

## 5. TEST RESULTS

### 5.6 Output Terminal Conducted Spurious Emission Measurement

EUT	DIRECTV DVR / SIR-S4120R, SIR-S4080R, SIR-S4040R
Limit apply to	FCC Part15 Subpart B Section 15.115(b)(2)
Test Date	May 14, 2004
Operating Condition	HDD Play + Time Shift Recording with TV Mode (CH. 3 & CH. 4)
Environment Condition	Humidity Level : 36%RH, Temperature : 20
Result	Passed by 15.86dB

**Test Data Table**

Test Channel	Emission Frequency [MHz]	Meter Reading [dB $\mu$ V]	Correction Factor [dB]	Signal Level [dB $\mu$ V]	Limit [dB $\mu$ V]	Margin [dB]
3	47.6	14.85	7.5	22.35	39.50	17.15
	74.6	16.14		23.64	39.50	15.86
	122.5	15.73		23.23	39.50	16.27
	745.0	13.64		21.14	39.50	18.36
4	53.6	15.53		23.03	39.50	16.47
	80.6	14.45		21.95	39.50	17.55
	134.6	13.93		21.43	39.50	18.07
	494.0	13.37		20.87	39.50	18.63

**NOTES :**

1. The correction factor consist of the insertion loss of the impedance matching transformer, the coaxial cable used for the test and the gain of pre-amplifier.
2. The spectrum was checked in each test mode and operation mode, and the maximum measured data were reported.
3.  $Signal\ Level = Meter\ Reading + Correction\ Factor(Matching\ Loss)$   
 $Margin\ value = Limit - Signal\ Level$

*H. J. Kim*

Test Engineer : H.J. Kim

## 5. TEST RESULTS

### 5.7 Antenna Transfer Switch Measurement

EUT	DIRECTV DVR / SIR-S4120R, SIR-S4080R, SIR-S4040R
Limit apply to	FCC Part15 Subpart B Section 15.115(c)(1)
Test Date	May 14, 2004
Operating Condition	HDD Play + Time Shift Recording with TV Mode (CH. 3 & CH. 4)
Environment Condition	Humidity Level : 36 %RH, Temperature : 20
Result	Passed

**Test Data Table**

Test Channel	Emission Frequency [MHz]	Meter Reading [dB $\mu$ V]	Correction Factor [dB]	Emission Level [dB $\mu$ V]	Limit [dB $\mu$ V]	Margin [dB]
3	61.29	-	7.5	-	9.5	-
4	67.29	-	7.5	-	9.5	-

**NOTES :**

1. *No emission was observed during the test. The spectrum was checked in each test mode and operation mode*  
*Transfer switch isolation measurements were made on the Channel 3 or 4 video output frequency of 61.25 or 67.25MHz and both positions of the transfer switch were checked for compliance.*
2. *To clarify the emissions emanated from ANT. input terminal on the EUT, RF pre-amplifier was used. The gain of pre-amplifier at each frequency measured from the EUT was obtained after sufficient warm-up for stabilization of gain. The correction factor consist of the insertion loss of the impedance matching transformer, the coaxial cable used for the test and the gain of pre-amplifier.*
3. *Emission Level = Meter Reading + Correction Factor(Matching Loss)*  
*Margin value = Limit - Emission Level*
4. *Spectrum analyzer setting : Frequency Span 1MHz, Resolution bandwidth 100 kHz, Video bandwidth 3MHz, Detector function Peak mode.*

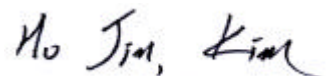

Test Engineer : H.J. Kim

## 6. SAMPLE CALCULATION

---

### Sample Field Strength Calculation

The field strength is calculated by adding the Antenna Factor and Cable Factor.  
The basic equation with a sample calculation is as follows:

$$FS = RA + AF + CF$$

where FS = Field Strength

RA = Receiver Amplitude

AF = Antenna Factor

CF = Cable Attenuation Factor

$$dB(\mu V/m) = 20 \log_{10} (\mu V / m) : \text{Equation 1}$$

$$dB\mu V = dBm + 107 : \text{Equation 2}$$

#### Example 1 : @2.580MHz

Class B Average Limit	=	46.0 dBuV = 200 uV
Reading	=	28.5 dBuV
Convert to uV	=	26.60 uV
Margin	=	46.0 – 28.5 = 17.5
	=	17.5 dB below Limit

#### Example 2 : @30.7MHz

Class B Limit	=	100 uV = 40.0 dBuV/m
Reading	=	22.14 dBuV
Antenna Factor + Cable Loss	=	14.56 dB
Total	=	36.7 dBuV/m
Margin	=	40.0 – 36.7 = 3.3
	=	3.3 dB below Limit

*This report only responds to the tested sample and may not be reproduced, except in full, without written approval of the ETL, Inc.*

## 7. TEST EQUIPMENTS LIST

### List of Test Equipments Used for Measurements

	Model Number	Manufacturer	Description	Serial Number	Cal Due Date
■	R3261A	Advantest	Spectrum Analyzer	21720033	04.10.24
■	ESVS10	Rohde & Schwarz	EMI TEST Receiver	835165/001	05.04.12
■	E7401A	H.P	Spectrum Analyzer	US38440057	05.04.12
□	E7402A	H.P	Spectrum Analyzer	US39110107	04.06.07
□	ESHS30	Rohde & Schwarz	EMI TEST Receiver	0401901/002	05.03.29
■	3825/2	EMCO	LISN	9006-1669	05.04.13
■	3825/2	EMCO	LISN	9208-1995	05.01.29
■	VULB9160	Schwarz Beck	Trilog Antenna	3082	04.07.16
□	VULB9165	Schwarz Beck	LogBicon Antenna	2023	04.07.05
□	VHAP	Schwarz Beck	Dipole Antenna	964,965	04.07.05
□	UHAP	Schwarz Beck	Dipole Antenna	949,950	04.05.17
□	MDS-21	Rohde & Schwarz	Absorbing Clamp	831676/013	04.08.25
■	RAM	Rohde & Schwarz	Matching Pad	836964 / 009	04.10.24
□	ISN T200	Schaffner	Impedance Stabilization Network	15973	N/A
■	CCN1000-1LR1	Schaffner	Flicker Meter	X71836	05.05.08
■	ProfLine 2105-400	Schaffner	AC Power Source	HK53887	04.10.24
□	FCC-2031-DCN-32mm	FCC	Coupling Decoupling Network	None	N/A

*This report only responds to the tested sample and may not be reproduced, except in full, without written approval of the ETL, Inc.*