



Nemko Korea Co., Ltd.

155 & 159, Osan-Ro, Mohyeon-Myeon, Cheoin-Gu, Yongin-Si, Gyeonggi-Do 449-852 KOREA, REPUBLIC OF

TEL:+82 31 330-1700 FAX:+82 31 322 2332

FCC EVALUATION REPORT FOR CERTIFICATION

Applicant :

Samsung Electronics Co., Ltd.
129, Samsung-ro, Yeongtong-gu,
Suwon-si, Gyeonggi-do, Korea.
(Post code : 443-742)
Attn. : Minhyung. Cho

Dates of Issue : June 16, 2015
Test Report No. : NK-15-R-056
Test Site : Nemko Korea Co., Ltd.

FCC ID

A3LCYLHDE01A

Brand Name

SAMSUNG

Contact Person

Samsung Electronics Co., Ltd.
129, Samsung-ro, Yeongtong-gu,
Suwon-si, Gyeonggi-do, Korea, 443-742.
Mr. Minhyung Cho
Telephone No. : +82-31-277-2688

Applied Standard: FCC 47 CFR Part 15.247
Classification: Digital modulation Transmitter
EUT Type: ZigBee/Z-wave Dongle

The device bearing the brand name and model specified above has been shown to comply with the applicable technical standards as indicated in the measurement report and was tested in accordance with the measurement procedures specified in ANSI C63.10 - 2009. The client should not use it to claim product endorsement by TAF or any government agencies. The test results in the report only apply to the tested sample.

I attest to the accuracy of data and all measurements reported herein were performed by me or were made under my supervision and are correct to the best of my knowledge and belief. I assume full responsibility for the completeness of these measurements and vouch for the qualifications of all persons taking them.

Jun 16, 2015

Tested By : Wonho Son
Engineer

Reviewed By : Deokha Ryu
Technical Manager

TABLE OF CONTENTS

1. Scope	4
2. Introduction (Site Description)	5
2.1 Test facility	5
2.2 Accreditation and listing	6
3. Test Conditions & EUT Information	7
3.1 Operation During Test	7
3.1.1 Table of test power setting	7
3.1.2 Table of test channels	7
3.1.3 Table of test modes	8
3.1.4 Antenna information	8
3.2 Support Equipment	9
3.3 Setup Drawing	9
3.4 EUT Information	10
4. Summary of Test Results	11
5. Recommendation / Conclusion	12
6. Antenna Requirements	12
7. Description of Test	13
7.1 Conducted Emissions	13
7.2 Radiated Emissions	14
7.3 6 dB Bandwidth	15
7.4 Peak Output Power	16
7.5 Peak Power Spectral Density	17
7.6 Conducted Spurious Emissions	18
7.7 Duty Cycle	19
8. Test Data	20
8.1 Conducted Emissions	20

8.2 Radiated Emissions	23
8.3 6 dB Modulated Bandwidth	25
8.4 Peak Output Power	28
8.5 Peak Power Spectral Density	31
8.6 Conducted Spurious Emissions	34
8.7 Radiated Spurious Emissions	38
8.8 Radiated Band Edge	41
9. Test Equipment	42
10. Accuracy of Measurement	43
Appendix A: Labelling Requirement	45
Appendix B: Photographs of Test Set-up	46
Appendix C: EUT Photographs	49
Appendix D: Maximum Permissible Exposure	58

1. SCOPE

Measurement and determination of electromagnetic emissions (EME) of radio frequency devices including intentional and/or unintentional radiators for compliance with the technical rules and regulations of the Federal Communications Commission under FCC part 15.

Responsible Party :	Samsung Electronics Co., Ltd.
Contact Person :	Minhyung Cho
Manufacturer :	Samsung Electronics Co., Ltd. 129, Samsung-ro, Yeongtong-gu, Suwon-si, Gyeonggi-do, Korea 443-742

- FCC ID: A3LCYLHDE01A
- Model: CY-LHDE01A
- Brand Name: SAMSUNG
- EUT Type: ZigBee/Z-wave Dongle
- Classification: Digital modulation Transmitter
- Applied Standard: FCC 47 CFR Part 15.247

- Test Procedure(s): ANSI C63.10-2009
and FCC guidance of 558074 D01 v03r03

- Dates of Test: June 04, 2015 ~ June 15, 2015
- Place of Tests: Nemko Korea Co., Ltd.

2. INTRODUCTION

2.1 Test facility

The measurement procedure described in American National Standard for Testing Unlicensed Wireless Devices (ANSI C63.10-2009) was used in determining radiated and conducted emissions emanating from **Samsung Electronics Co., Ltd. FCC ID : A3LCYLHDE01A**

These measurement tests were conducted at **Nemko Korea Co., Ltd. EMC Laboratory**.

The site address 155 & 159, Osan-Ro, Mohyeon-Myeon, Cheoin-Gu, Yongin-Si, Gyeonggi-Do 449-852 KOREA, REPUBLIC OF.

The area of Nemko Korea Corporation Ltd. EMC Test Site is located in a mountain area at 80 km (48 miles) southeast and Incheon International Airport (Incheon Airport), 30 km (18miles) south-southeast from central Seoul.

It is located in the valley surrounded by mountains in all directions where ambient radio signal conditions are quiet and a favorable area to measure the radio frequency interference on open field test site for the computing and ISM devices manufactures.







The detailed description of the measurement facility was found to be in compliance with the requirements of §2.948 according to ANSI C63.4 2009.



Nemko Korea Co., Ltd.
 EMC Lab.
 155 & 159, Osan-Ro, Mohyeon-Myeon,
 Cheoin-Gu, Yongin-Si, Gyeonggi-Do
 449-852 KOREA, REPUBLIC OF
 Tel)+82-31-330-1700
 Fax)+82-31-322-2332

Fig. 1. The map above shows the Seoul in Korea vicinity area.
 The map also shows Nemko Korea Corporation Ltd. EMC Lab. and Incheon Airport.

2.2 Accreditation and listing

Accreditation type		Accreditation number
	CAB Accreditation for DOC	Designation No. KR0026
	KOLAS Accredited Lab. (Korea Laboratory Accreditation Scheme)	Registration No. 155
	Canada IC Registered site	Site No. 2040E
	VCCI registration site(RE/CE/Telecom CE)	Member No. 2118
	EMC CBTL	-
	KCC(RRL)Designated Lab.	Registration No. KR0026

3. TEST CONDITIONS & EUT INFORMATION

3.1 Operation During Test

The EUT is the transceiver which is the module supporting the Zigbee mode. (1Tx / 1Rx)
 During the test, the EUT was connected to laptop PC and then a test program was executed to operate duty cycle of EUT continuously (Duty cycle > 98%).
 The EUT was tested at the lowest channel, middle channel and the highest channel with the maximum output power in accordance with the manufacturer’s specifications. The worst data were recorded in the report.

3.1.1 Table of test power setting

Frequency	Power setting Level
2405 MHz	8
2440 MHz	8
2480 MHz	-6

3.1.2 Table of test channels

Frequency band	Mode	Test Channel (CH)	Frequency (MHz)
2.4 GHz	802.15.4	11	2405
		18	2440
		26	2480

3.1.3 Table of test modes

Test Items	Mode	Data rate (kbps)	Test Channel (CH)
Conducted Emissions	802.15.4	250	18
Radiated Emissions	802.15.4	250	18
6 dB Bandwidth	802.15.4	250	11/18/26
Peak Output Power	802.15.4	250	11/18/26
Peak Power Spectral Density	802.15.4	250	11/18/26
Conducted Spurious Emission, Radiated Spurious Emission	802.15.4	250	11/18/26
Band edge Emission	802.15.4	250	11/26

3.1.4 Antenna information:

Frequency band	Mode	Antenna TX mode	Support MIMO
900 MHz	Z-wave	<input checked="" type="checkbox"/> 1TX, <input type="checkbox"/> 2TX	<input type="checkbox"/> Yes, <input checked="" type="checkbox"/> No
2.4 GHz	Zigbee	<input checked="" type="checkbox"/> 1TX, <input type="checkbox"/> 2TX	<input type="checkbox"/> Yes, <input checked="" type="checkbox"/> No

3.2 Support Equipment

EUT	Samsung Electronics Co., Ltd. FCC ID: A3LCYLHDE01A	S/N: N/A
Laptop Computer	Samsung Electronics Co., Ltd Model : NT-RF510	FCC DOC S/N : ZZVL93EB301801H
AC/DC Adapter	Chicony Power Technology Co., Ltd Model : A10-090P1A 1.5 m unshielded power cable	FCC DOC S/N : AD-9019S

3.3 Setup Drawing

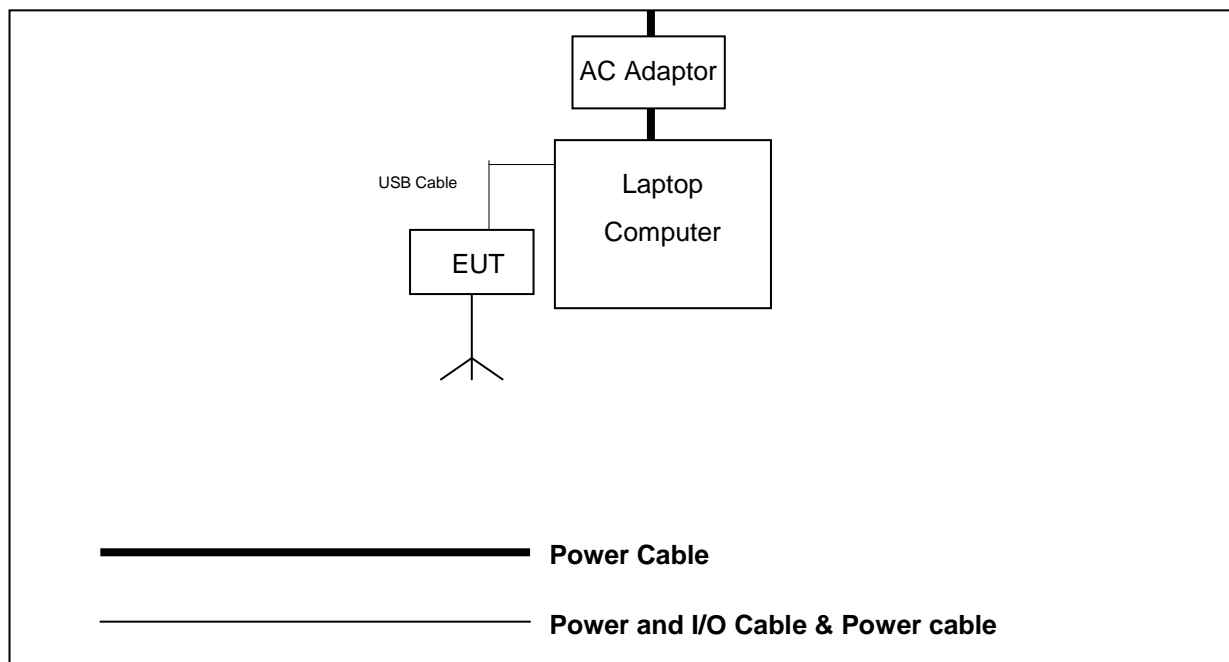

3.4 EUT Information

The EUT is the **Samsung Wireless Zigbee Dongle FCC ID: A3LCYLHDE01A.**

Specifications:

Category	ZigBee/Z-wave Dongle
Model Name	CY-LHDE01A
Brand Name	SAMSUNG
Frequency of Operation	2405 MHz ~ 2480 MHz
Power Output (Conducted)	5.41dBm
Channels	16 CH
Antenna Gain (peak)	Zigbee Ant : 4.0 dBi Z-wave Ant : 3.9 dBi
Antenna Setup	1TX / 1RX
Modulations	DSSS(O-QPSK) for 802.15.4
Temperature Range	-20 °C ~ +50 °C
Voltage	5.0 Vdc
Dimensions (L x W x T)	83 mm x 35 mm X 8 mm
Weight	47 g
H/W Status	01
S/W Status	01
Remarks	-

4. SUMMARY OF TEST RESULTS

The EUT has been tested according to the following specification:

Name of Test	FCC Paragraph No.	Result	Remark
Conducted Emission	15.207	Complies	
Radiated Emission	15.205 & 15.209	Complies	
6 dB Bandwidth	15.247(a)(2)	Complies	
Peak Power Output	15.247(b)(3)	Complies	
Power Spectral Density	15.247(e)	Complies	
Conducted Spurious Emission	15.247(d)	Complies	
Radiated Spurious Emission	15.247(d)	Complies	

5. RECOMMENDATION/CONCLUSION

The data collected shows that the **Samsung ZigBee/Z-wave Dongle FCC ID:A3LCYLHDE01A** is in compliance with Part 15.247 of the FCC Rule.

6. ANTENNA REQUIREMENTS

§15.203 of the FCC Rules part 15 Subpart C

: An intentional radiator shall be designed to ensure that no antenna other than that furnished by the responsible party shall be used with the device. The use of a permanently attached antenna or of an antenna that uses a unique coupling to the intentional radiator shall be considered sufficient to comply with the provisions of this section.

The antenna of the **Samsung ZigBee/Z-wave Dongle FCC ID: A3LCYLHDE01A** is **permanently attached** and there are no provisions for connection to an external antenna. It complies with the requirement of §15.203.

7. DESCRIPTION OF TESTS

7.1 Conducted Emissions

The Line conducted emission test facility is located inside a 4 x 7 x 2.5 meter shielded enclosure. It is manufactured by EM engineering. The shielding effectiveness of the shielded room is in accordance with MIL-STD-285 or NSA 65-6. A 1 m x 1.5 m wooden table 0.8 m height is placed 0.4 m away from the vertical wall and 1.5 m away from the side of wall of the shielded room Rohde & Schwarz (ESH3-Z5) and (ESH2-Z5) of the 50 ohm/50 μ H Line Impedance Stabilization Network (LISN) are bonded to the shielded room. The EUT is powered from the Rohde & Schwarz LISN (ESH3-Z5) and the support equipment is powered from the Rohde & Schwarz LISN (ESH2-Z5). Power to the LISNs are filtered by high-current high insertion loss Power line filters. The purpose of filter is to attenuate ambient signal interference and this filter is also bonded to shielded enclosure. All electrical cables are shielded by tinned copper zipper tubing with inner diameter of 1 / 2 ". If DC power device, power will be derived from the source power supply it normally will be powered from and this supply lines will be connected to the LISNs, All interconnecting cables more than 1 meter were shortened by non inductive bundling (serpentine fashion) to a 1 meter length. Sufficient time for EUT, support equipment, and test equipment was allowed in order for them to warm up to their normal operating condition. The RF output of the LISN was connected to the spectrum analyzer to determine the frequency producing the maximum EME from the EUT. The spectrum was scanned from 150 kHz to 30 MHz with 200 msec sweep time. The frequency producing the maximum level was re-examined using the EMI test receiver. (Rohde & Schwarz ESCS30). The detector functions were set to CISPR quasi-peak mode & average mode. The bandwidth of receiver was set to 9 kHz. The EUT, support equipment, and interconnecting cables were arranged and manipulated to maximize each EME emission. Each emission was maximized by; switching power lines; varying the mode of operation or resolution; clock or data exchange speed; scrolling H pattern to the EUT and of support equipment, and powering the monitor from the floor mounted outlet box and computer aux AC outlet, if applicable; whichever determined the worst case emission. Each EME reported was calibrated using the R&S signal generator.

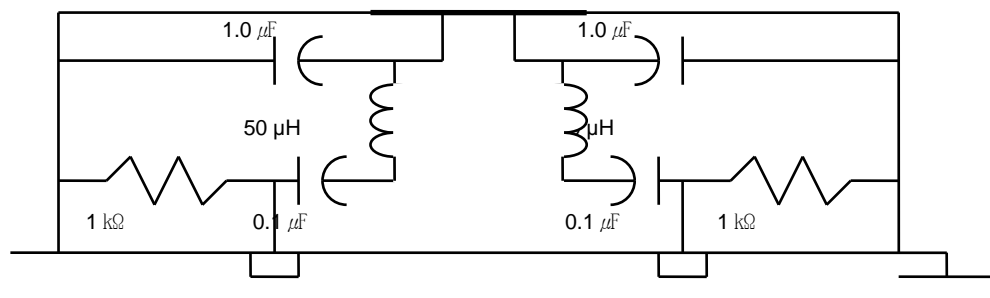

Fig. 2. LISN Schematic Diagram

7.2 Radiated Emissions

The measurement was performed at the test site that is specified in accordance with ANCI C63.10-2009.

The spurious emission was scanned from 9 kHz to 30 MHz using Loop Antenna(Rohde&Schwarz, HFH2-Z2) and 30 to 1000 MHz using Trilog broadband test antenna(Schwarzbeck, VULB 9163). Above 1 GHz, Horn antenna (Schwarzbeck BBHA 9120D: up to 18 GHz, Q-par Angus QSH20S20 : 18 to 26.5 GHz, QSH22K20: up to 40 GHz) was used.

For emissions testing at below 1GHz, The test equipment was placed on turntable with 0.8 m above ground. For emission measurements above 1 GHz, The test equipment was placed on turntable with 1.5 m above ground. Sufficient time for the EUT, support equipment, and test equipment was allowed in order for them to warm up to their normal operating condition. The EUT, cable, wire arrangement and mode of operation that has the highest amplitude relative to the limit was selected. Then, the turn table was rotated from 0° to 360° and an antenna mast was moved from 1 m to 4 m height to maximize the suspected highest amplitude signal. The final maximized level was recorded.

At frequencies below 1000 MHz, measurements performed using the CISPR quasi-peak detection. At frequencies above 1000 MHz, measurements performed using the peak and average measurement procedures described in KDB “558074 D01 DTS Meas Guidance v03r03” in section 12.2.4 and 12.2.5.2. Peak emission levels were measured by setting the analyzer RBW = 1 MHz, VBW = 3 MHz, Detector = Peak, Trace mode = max hold. Average emission levels were measured by setting the analyzer RBW = 1 MHz, VBW = 3 MHz, Detector = RMS, Trace averaging in power averaging (RMS) mode over a minimum of 100 traces, when the EUT was configured to transmit with duty cycle ≥ 98 percent. If continuous transmission of the EUT couldn't be achieved and duty cycle was constant, a correction factor (10 log (1 / x)) was added to the measurement result.

Frequency (MHz)	Field strength (microvolts/meter)	Measurement distance (meters)
0.009–0.490	2400/F(kHz)	300
0.490–1.705	24000/F(kHz)	30
1.705–30.0	30	30
30–88	100	3
88–216	150	3
216–960	200	3
Above 960	500	3

Radiated Emissions Limits per 47 CFR 15.209(a)

Note :

**Instead of 0.8m EUT height above 1GHz, 1.5m was used as allowed by FCC December 2014 TCB Conference call.*

7.3 6 dB Bandwidth

Test Setup

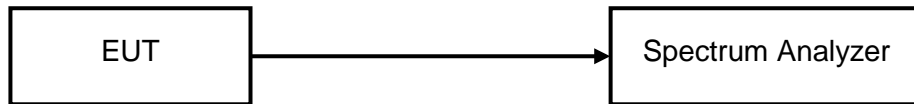

Test Procedure

EUTs 6 dB bandwidth is measured at low, middle, high channels with a spectrum analyzer connected to the antenna terminal while the EUTs operating at its maximum power control level.

The spectrum analyzer setting is as follows.

RBW = 100 kHz

VBW \geq 3 x RBW

Detector = Peak

Trace mode = max hold

Sweep = auto couple

The bandwidth measurement function on the spectrum analyzer is used to measure the 6 dB bandwidth.

7.4 Maximum Peak Output Power

Test Setup

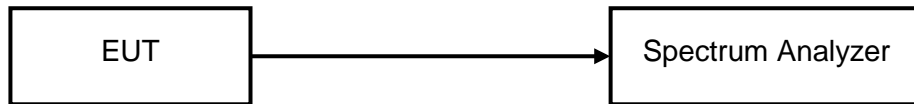

Test Procedure

EUTs Maximum Peak Conducted Output Power is measured at low, middle, high channels with a spectrum analyzer connected to the antenna terminal while the EUTs operating at its maximum power control level.

The spectrum analyzer setting is as follows.

RBW \geq DTS bandwidth

VBW $\geq 3 \times$ RBW

Span $\geq 3 \times$ RBW

Detector = peak

Sweep time = auto couple

Trace mode = Max hold

Allow the trace to stabilize.

Use peak marker function to determine the peak amplitude level.

7.5 Peak Power Spectral Density

Test Setup

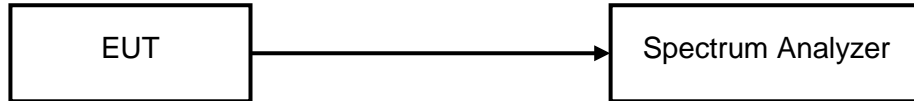

Test Procedure

EUTs Peak Power Spectral Density is measured at low, middle, high channels with a spectrum analyzer connected to the antenna terminal while the EUTs operating at its maximum power control level.

The spectrum analyzer setting is as follows.

Center frequency = DTS channel center frequency

Span = 1.5 times the DTS channel bandwidth

RBW to : $3 \text{ kHz} \leq \text{RBW} \leq 100 \text{ kHz}$

VBW $\geq 3 \times \text{RBW}$

Detector = peak

Sweep time = auto couple

Trace mode = max hold

Allow the trace to stabilize.

The peak search function on the spectrum analyzer is used to determine the maximum amplitude level within the fundamental DTS bandwidth.

7.6 Conducted Spurious Emissions

Test Setup

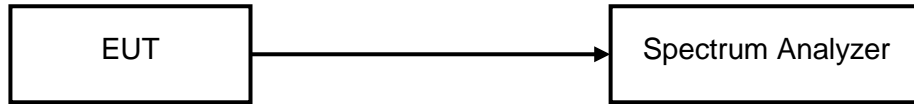

Test Procedure

EUTs Conducted spurious emissions are measured at low, middle, high channels with a spectrum analyzer connected to the antenna terminal while the EUTs operating at its maximum power control level. The spectrum analyzer setting is as follows.

1) Reference Level

Center frequency = DTS channel center frequency

Span \geq 1.5 times the DTS bandwidth

RBW = 100 kHz

VBW \geq 3 x RBW

Detector = peak

Sweep time = auto couple

Trace mode = max hold

Allow trace to fully stabilize.

The peak search function on the spectrum analyzer is used to determine the maximum PSD level.

2) Unwanted Emissions

Set the center frequency and span to encompass frequency range to be measured.

RBW = 100 kHz

VBW \geq 3 x RBW

Detector = peak

Sweep time = auto couple

Trace mode = max hold

Allow trace to fully stabilize.

The peak marker function on the spectrum analyzer is used to determine the maximum amplitude level of all unwanted emissions outside of the authorized frequency band. The unwanted emissions are attenuated by at least the minimum requirements specified.

7.7 Duty Cycle

Test Setup

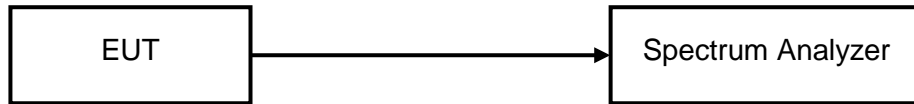

Test Procedure

EUTs duty cycle are measured at middle channel with a spectrum analyzer connected to the antenna terminal while the EUTs operating at its maximum power control level. The spectrum analyzer setting is as follows.

Center frequency = Center frequency of the transmission

Span = zero

RBW = 20 MHz

VBW = 20 MHz

Detector = peak

Sweep time = 5 ms

Trace mode = view

The marker function on the spectrum analyzer is used to determine the duty cycle.

Following the result of the duty cycle measurement according to the above test procedure

Frequency (MHz)	Data Rate (kbps)	Duty Cycle (%)
2405	250	100
2440	250	100
2480	250	100



8. TEST DATA

8.1 Conducted Emissions

FCC §15.207

Frequency (MHz)	Level(dBμV)		*)Factor (dB)	**) Line	Limit(dBμV)		Margin(dB)	
	Q-Peak	Average			Q-Peak	Average	Q-Peak	Average
0.15	45.6	24.2	10.3	L	66.0	56.0	20.4	31.8
0.17	41.2	22.2	10.3	L	65.0	55.0	23.8	32.8
0.19	43.2	22.9	10.3	L	64.0	54.0	20.8	31.1
0.21	37.3	22.3	10.3	L	63.2	53.2	25.9	30.9
0.23	33.2	22.2	10.3	L	62.4	52.4	29.2	30.2
0.41	32.3	27.6	10.4	L	57.6	47.6	25.3	20.0

Line Conducted Emissions Tabulated Data

Notes:

1. Measurements using CISPR quasi-peak mode & average mode.
2. All modes of operation were investigated and the worst -case emission are reported. See attached Plots.
3. *) Factor = LISN + Cable Loss
4. **) LINE : L = Line , N = Neutral
5. The limit is on the FCC Part section 15.207(a).

PLOTS OF EMISSIONS

● **Conducted Emission at the Mains port (Line)**

NEMKO KOREA (NK-15-R-056)

04 Jun 2015 10:01

Conducted Emissions

EUT: EUT
 Manuf: Samsung Electronics Co., Ltd.
 Op Cond: a.c. 120 V / 60 Hz, Zigbee
 Operator: Wonho. Son
 Test Spec: FCC Part 15
 Comment: MODEL : CY-LHDE01A
 LINE : LINE-PE
 Result File: r56_zb_l.dat : New Measurement

Scan Settings (1 Range)

Frequencies			Receiver Settings						
Start	Stop	Step	IF BW	Detector	M-Time	Atten	Preamp	OpRge	
150kHz	30MHz	3.9063kHz	9kHz	PK+AV	20msec	20 dB	OFF	60dB	

Transducer	No.	Start	Stop	Name
	1	150kHz	30MHz	ESH3_Z5_Line

Final Measurement: Detectors: X QP / + AV
 Meas Time: 1sec
 Subranges: 8
 Acc Margin: 60 dB

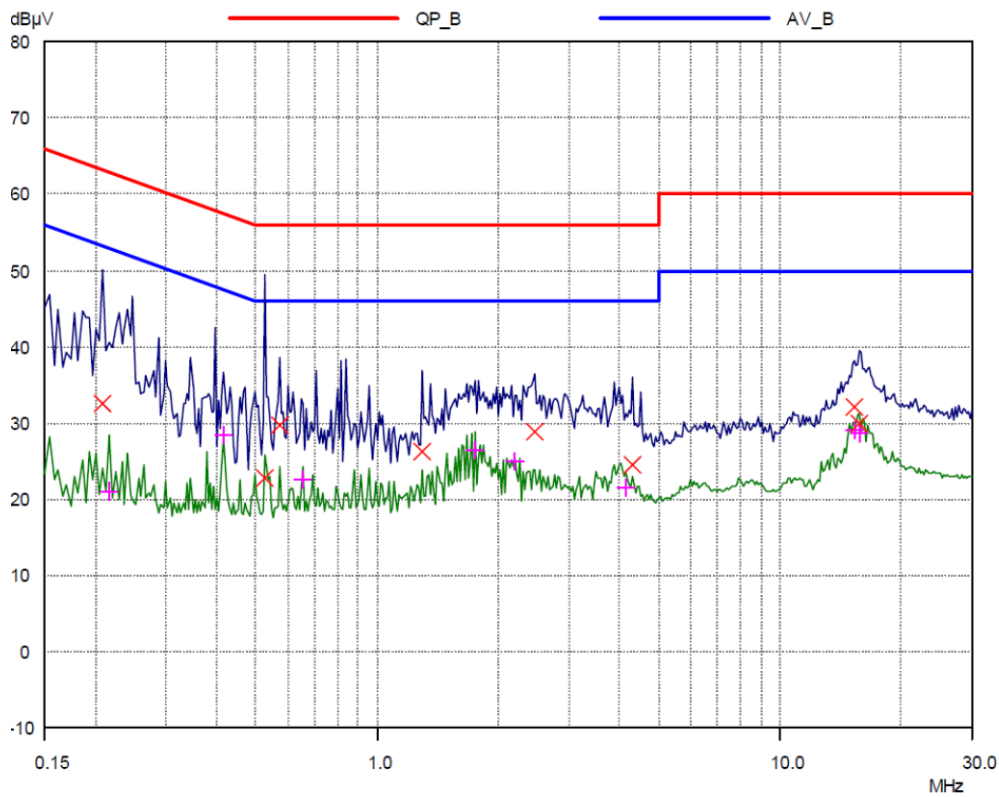

PLOTS OF EMISSIONS

● **Conducted Emission at the Mains port (Neutral)**

NEMKO KOREA (NK-15-R-056)

04 Jun 2015 10:08

Conducted Emissions

EUT: EUT
 Manuf: Samsung Electronics Co., Ltd.
 Op Cond: a.c. 120 V / 60 Hz, Zigbee
 Operator: Wonho. Son
 Test Spec: FCC Part 15
 Comment: MODEL : CY-LHDE01A
 LINE : NEUTRAL-PE
 Result File: r56_zbn1.dat : New Measurement

Scan Settings (1 Range)

Frequencies			Receiver Settings						
Start	Stop	Step	IF BW	Detector	M-Time	Atten	Preamp	OpRge	
150kHz	30MHz	3.9063kHz	9kHz	PK+AV	20msec	20 dB	OFF	60dB	

Transducer	No.	Start	Stop	Name
	1	150kHz	30MHz	ESH3_Z5_Neutral

Final Measurement: Detectors: X QP / + AV
 Meas Time: 1sec
 Subranges: 8
 Acc Margin: 60 dB

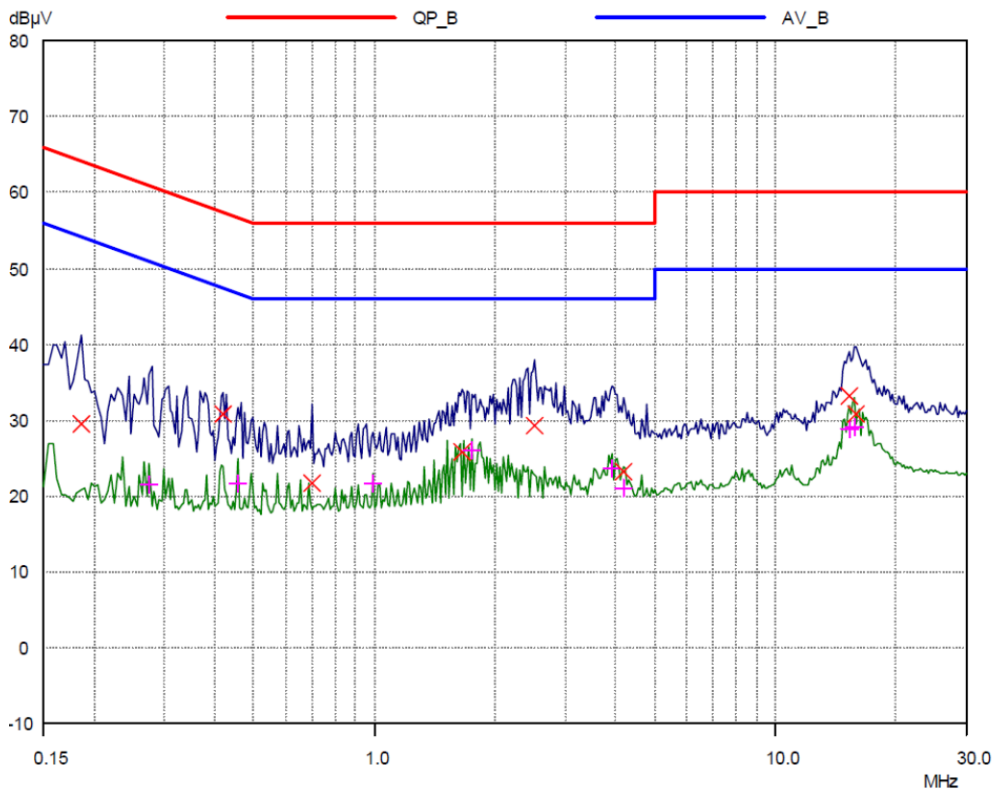

TEST DATA

8.2 Radiated Emissions

FCC §15.209

Frequency (MHz)	Reading (dBµV/m)	Pol* (H/V)	Antenna Heights (cm)	Turntable Angles (°)	AF+CL+Amp (dB)**	Result (dBµV/m)	Limit (dBµV/m)	Margin (dB)
228.07	53.60	H	130	282	-23.1	30.5	46.0	15.5
294.66	56.70	H	100	278	-20.7	36.0	46.0	10.0
461.26	46.40	H	170	17	-15.8	30.6	46.0	15.4
480.03	50.40	H	200	237	-15.3	35.1	46.0	10.9
833.31	51.10	H	100	52	-9.9	41.2	46.0	4.8
877.83	44.30	H	170	63	-9.2	35.1	46.0	10.9

Radiated Measurements at 3meters

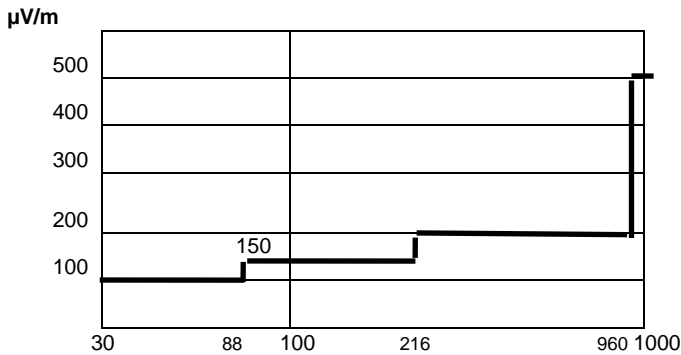

Fig. 3. Limits at 3 meters

Notes:

1. All modes were measured and the worst-case emission was reported.
2. The radiated limits are shown on Figure 3. Above 1 GHz the limit is 500 µV/m.

3. *Pol. H = Horizontal, V = Vertical
4. **AF + CL + Amp. = Antenna Factor + Cable Loss + Amplifier.
5. Measurements using CISPR quasi-peak mode.
6. The radiated emissions testing were made by rotating through three orthogonal axes. The worst date was recorded.
7. There were no radiated emissions other than harmonics found below 30 MHz. This is worst case channel.(2440MHz)

PLOTS OF EMISSIONS

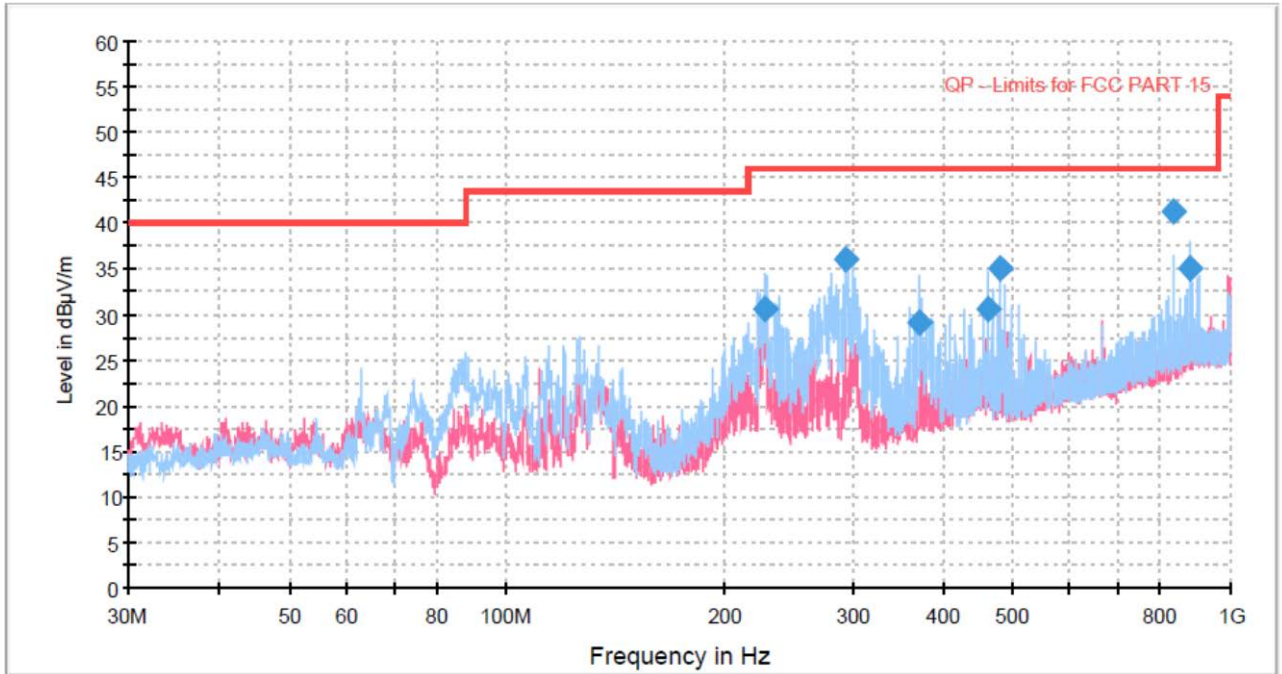

TEST DATA

8.3 6 dB Modulated Bandwidth

FCC §15.247(a)(2)

Test Mode : Set to Lowest channel, Middle channel and Highest channel

Result

Channel	Frequency (MHz)	6 dB modulated bandwidth (MHz)	Limit (MHz)	Margin (MHz)
Lowest	2405	1.71	0.50	1.21
Middle	2440	1.65	0.50	1.15
Highest	2480	1.63	0.50	1.13

PLOTS OF EMISSIONS

6 dB Bandwidth, Lowest Channel (2405 MHz)



6 dB Bandwidth, Middle Channel (2440 MHz)



PLOTS OF EMISSIONS

6 dB Bandwidth, Highest Channel (2480 MHz)



TEST DATA

8.4 Peak Output Power

FCC §15.247(b)(3)

Test Mode : Set to Lowest channel, Middle channel and Highest channel

Result

Frequency (MHz)	Data rate (kbps)	Conducted Output Power (dBm)	Limit (dBm)	Margin (dB)
2405	250	4.95	30.00	25.05
2440	250	5.41	30.00	24.59
2480	250	-9.01	30.00	39.01

Note:

The following equation was used for spectrum offset:

$Spectrum\ offset\ (dB) = Attenuator\ (dB) + Cable\ Loss\ (dB) + SMA\ Type\ Connector\ Loss\ (dB)$

PLOT OF TEST DATA

Peak Output Power, Lowest Channel (2405 MHz)

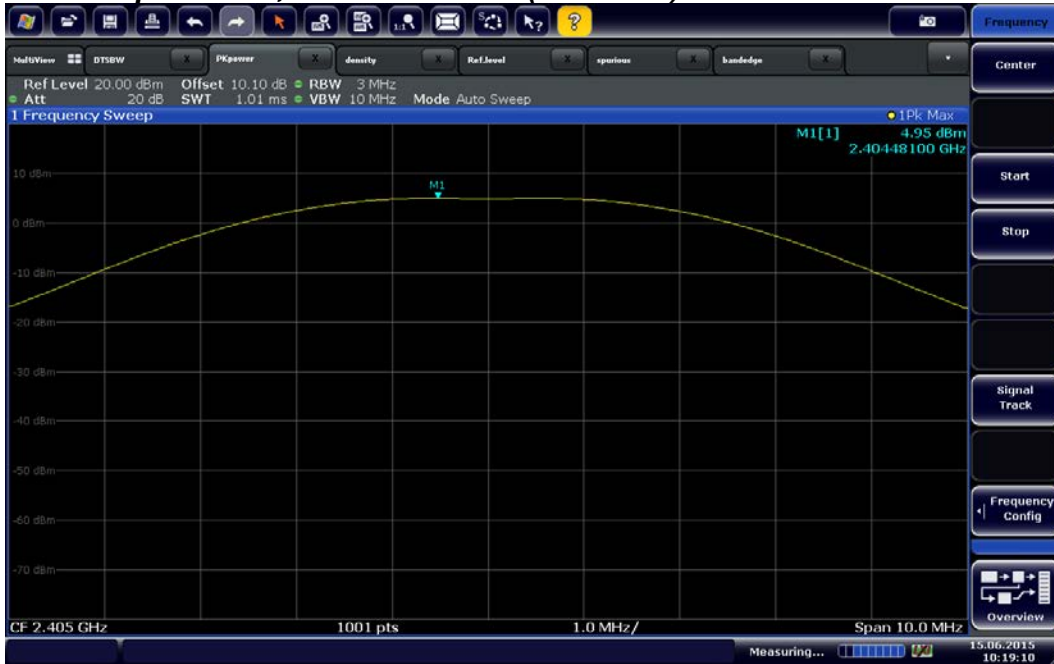

Peak Output Power, Middle Channel (2440 MHz)

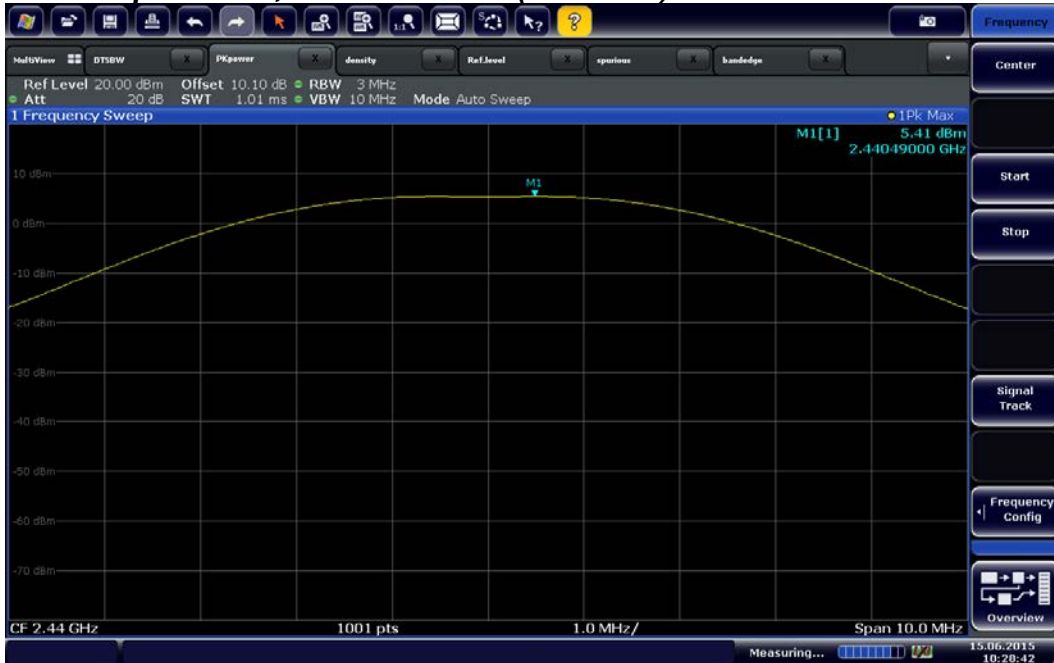

PLOT OF TEST DATA

Peak Output Power, Highest Channel (2480 MHz)

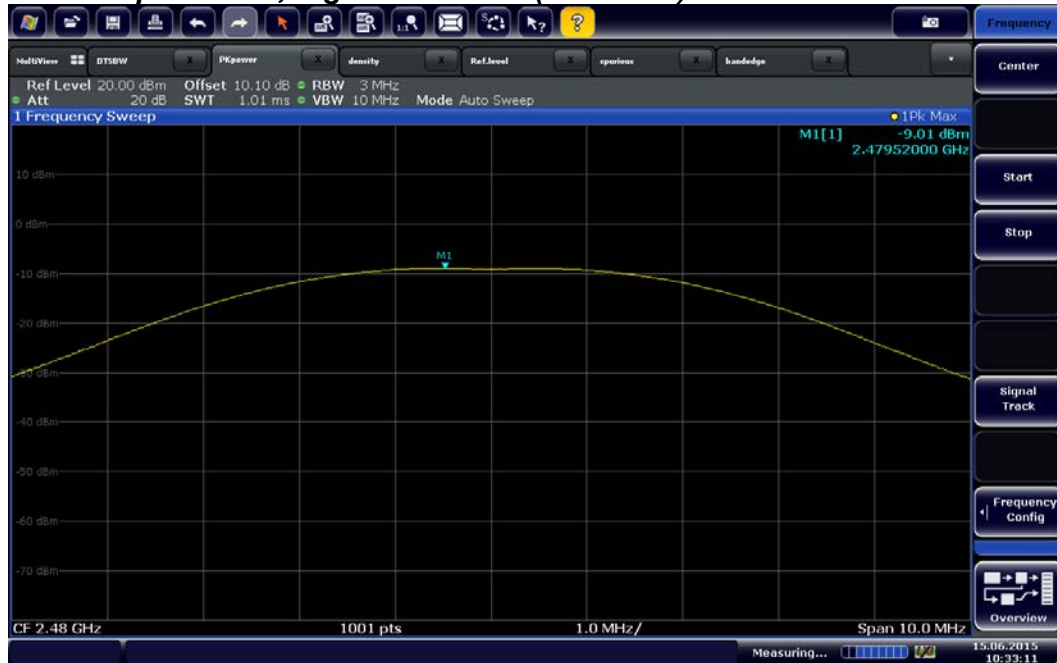

TEST DATA

8.5 Peak Power Spectral Density

FCC §15.247(e)

Test Mode : Set to Lowest channel, Middle channel and Highest channel

Result

Channel	Frequency(MHz)	Result(dBm/100kHz)	Limit (dBm/3kHz)
Low	2405	0.21	8.0
Middle	2440	1.14	8.0
High	2480	-13.31	8.0

Note:

The following equation was used for spectrum offset:

$\text{Spectrum offset (dB)} = \text{Attenuator (dB)} + \text{Cable Loss (dB)} + \text{SMA Type Connector Loss (dB)}$

PLOT OF TEST DATA

Peak Power Spectral Density, Lowest Channel (2405 MHz)



Peak Power Spectral Density, Middle Channel (2440 MHz)



PLOT OF TEST DATA

Peak Power Spectral Density, Highest Channel (2480 MHz)



TEST DATA

8.6 Conducted Spurious Emissions

FCC §15.247(d)

Test Mode : Set to Lowest channel, Middle channel and Highest channel

802.11b mode

Channel	Frequency (MHz)	Reference Level (dBm)	Conducted Spurious Emissions (dBc)	Limit (dBc)
Low	2405	0.21	More than 20 dBc	20
Middle	2440	1.14	More than 20 dBc	20
High	2480	-13.31	More than 20 dBc	20

PLOT OF TEST DATA

Conducted Spurious Emissions, 30 MHz ~ 26.5 GHz (2405 MHz)



Conducted Spurious Emissions, 30 MHz ~ 26.5 GHz (2440 MHz)



PLOT OF TEST DATA

Conducted Spurious Emissions, 30 MHz ~ 26.5 GHz (2480 MHz)



PLOT OF TEST DATA

Band Edge, Lowest Channel (2405 MHz)



Band Edge, Highest Channel(2480 MHz)



TEST DATA

8.7 Radiated Spurious Emissions

FCC §15.247(d)

Test Mode : Set to Lowest channel, Middle channel and Highest channel

Result

Lowest Channel (2405MHz)

Frequency (MHz)	Reading (dBμV/m)	Pol* (H/V)	Detector	AF+CL+Amp (dB)**	Result (dBμV/m)	Limit (dBμV/m)	Margin (dB)
1496.50	48.7	H	Peak	-3.0	45.7	74.0	28.3
1496.50	42.7	H	Average	-3.0	39.7	54.0	14.3
1671.25	49.7	V	Peak	-2.3	47.4	74.0	26.6
1671.25	37.7	V	Average	-2.3	35.4	54.0	18.6
2244.50	46.6	V	Peak	-0.4	46.2	74.0	27.8
2244.50	36.3	V	Average	-0.4	35.9	54.0	18.1
2725.25	46.0	H	Peak	1.3	47.3	74.0	26.7
2725.25	38.1	H	Average	1.3	39.4	54.0	14.6
4810.00	39.3	V	Peak	9.6	48.9	74.0	25.1
4810.00	30.2	V	Average	9.6	39.8	54.0	14.2

TEST DATA

Middle Channel (2440MHz)

Frequency (MHz)	Reading (dB μ V/m)	Pol* (H/V)	Detector	AF+CL+Amp (dB)**	Result (dB μ V/m)	Limit (dB μ V/m)	Margin (dB)
1497.75	48.9	H	Peak	-3.0	45.9	74.0	28.1
1497.75	39.4	H	Average	-3.0	36.4	54.0	17.6
1531.50	47.2	H	Peak	-2.8	44.4	74.0	29.6
1531.50	42.1	H	Average	-2.8	39.3	54.0	14.7
1663.50	48.8	V	Peak	-2.4	46.4	74.0	27.6
1663.50	36.6	V	Average	-2.4	34.2	54.0	19.8
2245.50	47.8	V	Peak	-0.4	47.4	74.0	26.6
2245.50	37.4	V	Average	-0.4	37.0	54.0	17.0
2725.50	43.5	H	Peak	1.3	44.8	74.0	29.2
2725.50	37.6	H	Average	1.3	38.9	54.0	15.1
4880.00	39.5	H	Peak	9.9	49.4	74.0	24.6
4880.00	29.8	H	Average	9.9	39.7	54.0	14.3

Highest Channel (2480MHz)

Frequency (MHz)	Reading (dB μ V/m)	Pol* (H/V)	Detector	AF+CL+Amp (dB)**	Result (dB μ V/m)	Limit (dB μ V/m)	Margin (dB)
1497.25	48.8	H	Peak	-3.0	45.8	74.0	28.2
1497.25	37.4	H	Average	-3.0	34.4	54.0	19.6
1671.00	49.5	V	Peak	-2.3	47.2	74.0	26.8
1671.00	38.6	V	Average	-2.3	36.3	54.0	17.7
1693.75	51.3	V	Peak	-2.3	49.0	74.0	25.0
1693.75	39.0	V	Average	-2.3	36.7	54.0	17.3
2246.75	46.2	V	Peak	-0.4	45.8	74.0	28.2
2246.75	34.3	V	Average	-0.4	33.9	54.0	20.1
4960.00	40.4	V	Peak	10.1	50.5	74.0	23.5
4960.00	29.1	V	Average	10.1	39.2	54.0	14.8

Note(s):

1. *Pol. H = Horizontal V = Vertical
2. **AF + CL + Amp. = Antenna Factor + Cable Loss + Amplifier.
3. The radiated emissions testing were made by rotating EUT through three orthogonal axes and rotating the receive antenna with horizontal, Vertical polarization. The worst data was recorded.
4. Peak emissions were measured using RBW = 1 MHz, VBW = 3 MHz, Detector = Peak
5. For average measurements, "12.2.5.1 Average Power Measurement Procedures" at "558074 D01 DTS Meas Guidance v03r03" was used.
6. The spectrum was measured from 9 kHz to 10th harmonic and the worst-case emissions were reported. No significant emissions were found beyond the 2nd harmonic for this device.

TEST DATA

8.8 Radiated Band Edge

FCC §15.247(d)

Test Mode : Set to Lowest channel and Highest channel

Result

Frequency (MHz)	Reading (dBμV/m)	Pol* (H/V)	Detector	AF+CL+Amp (dB)**	Result (dBμV/m)	Limit (dBμV/m)	Margin (dB)
2390.00	44.5	H	Peak	0.1	44.6	74.0	29.4
2390.00	36.7	H	Average	0.1	36.8	54.0	17.2
2483.50	60.9	H	Peak	0.6	61.5	74.0	12.5
2483.50	52.0	H	Average	0.6	52.6	54.0	1.5

Note(s):

1. *Pol. H = Horizontal V = Vertical
2. **AF + CL + Amp. = Antenna Factor + Cable Loss + Amplifier.
3. The radiated emissions testing were made by rotating EUT through three orthogonal axes and rotating the receive antenna with horizontal, Vertical polarization. The worst data was recorded.
4. Peak emissions were measured using RBW = 1 MHz, VBW = 3 MHz, Detector = Peak
5. For average measurements, "12.2.5.2 Average Power Measurement Procedures" at "558074 D01 DTS Meas Guidance v03r03" was used.

9. TEST EQUIPMENT

No.	Instrument	Manufacturer	Model	Serial No.	Calibration Date	Calibration Interval
1	*Test Receiver	R & S	ESU 40	100202	Apr. 01 2015	1 year
2	*Test Receiver	R & S	ESCS30	100302	Oct. 06 2014	1 year
3	*Attenuator	AGILENT	8491B	57773	Oct. 07 2014	1 year
4	*Attenuator	FAIRVIEW	SA3N5W-06	N/A	Apr. 01 2015	1 year
5	*Attenuator	FAIRVIEW	SA3N5W-10	N/A	Apr. 01 2015	1 year
6	*Attenuator	WEINSCHTEL	56-10	58765	Apr. 02 2015	1 year
7	*Amplifier	R & S	SCU 01	10030	Apr. 01 2015	1 year
8	*Amplifier	R & S	SCU18	10065	Apr. 01 2015	1 year
9	*Amplifier	R & S	SCU26	10011	Jul. 08 2014	1 year
10	*Amplifier	R & S	SCU40	10008	Jul. 08 2014	1 year
11	*Pre Amplifier	HP	8449B	3008A00107	Jan. 09 2015	1 year
12	Spectrum Analyzer	R & S	FSW43	100732	Apr. 07 2015	1 year
13	Spectrum Analyzer	Agilent	E4440A	MY44022567	Apr. 01 2015	1 year
14	*Spectrum Analyzer	R&S	FSP40	100361	Jul. 16 2014	1 year
15	*DC Power Supply	HP	6574A	US36340190	Jul. 16 2014	1 year
16	*Loop Antenna	R & S	HFH2-Z2	100279	Feb. 13 2014	2 year
17	Wideband Power Sensor	R & S	NRP-Z81	100634	Jul. 17 2014	1 year
18	*Horn Antenna	SCHWARZBECK	BBHA9120D	9120D-474	Sep. 01 2014	2 year
19	*Horn Antenna	Q-par Angus	QSH20S20	8179	Apr. 30 2015	2 year
20	*Horn Antenna	Q-par Angus	QSH22K20	8180	Apr. 30 2015	2 year
21	*Trilog-Broadband Antenna	SCHWARZBECK	VULB 9163	9163-423	Apr. 17 2014	2 year
22	*LISN	R & S	ESH3-Z5	833874/006	Oct. 06 2014	1 year
23	*Controller	INNCO	CO2000-G	CO2000/562/23890210/L	N/A	N/A
24	*Turn Table	INNCO	DT3000-3T	N/A	N/A	N/A
25	*Antenna Mast	INNCO	MA4000-EP	N/A	N/A	N/A
26	*Open Switch And Control Unit	R & S	OSP-120	100015	N/A	N/A
27	*Anechoic Chamber	Seo-Young EMC	N/A	N/A	N/A	N/A
28	*Position Controller	INNCO	CO2000	12480406/L	N/A	N/A
29	*Turn Table	INNCO	DS1200S	N/A	N/A	N/A
30	*Antenna Mast	INNCO	MA4000	N/A	N/A	N/A
31	*Anechoic Chamber	Seo-Young EMC	N/A	N/A	N/A	N/A
32	Shielded Room	Seo-Young EMC	N/A	N/A	N/A	N/A
33	*Open Switch And Control Unit	R & S	OSP-120	100081	N/A	N/A

*) Test equipment used during the test

10. ACCURACY OF MEASUREMENT

The Measurement Uncertainties stated were calculated in accordance with the requirements of measurement uncertainty contained in CISPR 16-4-2 with the confidence level of 95%

1. Conducted Uncertainty Calculation

Source of Uncertainty	X_i	Uncertainty of X_i		Coverage factor k	$u(X_i)$ (dB)	C_i	$C_i u(X_i)$ (dB)
		Value (dB)	Probability Distribution				
Receiver reading	RI	± 0.1	normal 1	1.000	0.1	1	0.1
Attenuation AMN-Receiver	LC	± 0.08	normal 2	2.000	0.04	1	0.04
AMN Voltage division factor	LAMN	± 0.8	normal 2	2.000	0.4	1	0.4
Sine wave voltage	dVSW	± 2.00	normal 2	2.000	1.00	1	1.00
Pulse amplitude response	dVPA	± 1.50	rectangular	1.732	0.87	1	0.87
Pulse repetition rate response	dVPR	± 1.50	rectangular	1.732	0.87	1	0.87
Noise floor proximity	dVNF	± 0.00	-	-	0.00	1	0.00
AMN Impedance	dZ	± 1.80	triangular	2.449	0.73	1	0.73
Ⓐ Mismatch	M	+ 0.70	U-Shaped	1.414	0.49	1	0.49
Ⓑ Mismatch	M	- 0.80	U-Shaped	1.414	- 0.56	1	- 0.56
Measurement System Repeatability	RS	0.05	normal 1	1.000	0.05	1	0.05
Remark	Ⓐ: AMN-Receiver Mismatch : + Ⓑ: AMN-Receiver Mismatch : -						
Combined Standard Uncertainty	Normal			± 1.88			
Expanded Uncertainty U	Normal ($k = 2$)			± 3.76			

2. Radiation Uncertainty Calculation

Source of Uncertainty	X_i	Uncertainty of X_i		Coverage factor k	$u(X_i)$ (dB)	C_i	$C_i u(X_i)$ (dB)
		Value (dB)	Probability Distribution				
Measurement System Repeatability	RI	0.34	normal 1	1.00	0.34	1	0.34
Receiver reading	dVsw	± 0.02	normal 2	2.00	0.01	1	0.01
Sine wave voltage	dVpa	± 0.17	normal 2	2.00	0.09	1	0.09
Pulse amplitude response	dVpr	± 0.92	normal 2	2.00	0.46	1	0.46
Pulse repetition rate response	dVnf	± 0.35	normal 2	2.00	0.18	1	0.18
Noise floor proximity	AF	± 0.50	normal 2	2.00	0.25	1	0.25
Antenna Factor Calibration	CL	± 2.00	rectangular	$\sqrt{3}$	1.15	1	1.15
Cable Loss	AD	± 1.00	normal 2	2.00	0.50	1	0.50
Antenna Directivity	AH	± 0.00	rectangular	$\sqrt{3}$	0.00	1	0.00
Antenna Factor Height Dependence	AP	± 2.00	rectangular	$\sqrt{3}$	1.15	1	1.15
Antenna Phase Centre Variation	AI	± 0.20	rectangular	$\sqrt{3}$	0.12	1	0.12
Antenna Factor Frequency Interpolation	SI	± 0.25	rectangular	$\sqrt{3}$	0.14	1	0.14
Site Imperfections	DV	± 4.00	triangular	$\sqrt{6}$	1.63	1	1.63
Measurement Distance Variation	Dbal	± 0.60	rectangular	$\sqrt{3}$	0.35	1	0.35
Antenna Balance	DCross	± 0.90	rectangular	$\sqrt{3}$	0.52	1	0.52
Cross Polarisation	M	± 0.00	rectangular	$\sqrt{3}$	0.00	1	0.18
Mismatch	M	+ 0.98 - 1.11	U-Shaped	$\sqrt{2}$	0.74	1	0.74
EUT Volume Diameter	M	0.33	normal 1	1.00	0.33	1	0.11
Remark							
Combined Standard Uncertainty	Normal						
Expanded Uncertainty U	Normal ($k = 2$)						