

EMC TEST REPORT



| | | | |
|---|--|---|--|
| Project No. | LBE20122200 | Issue No. | 0 |
| Applicant | Name of organization | Samsung Electronics Co., Ltd. | |
| | Address | 416 Maetan 3-Dong, Yeongtong-Gu, Suwon-Si, Gyeonggi-Do 443-742 Korea | |
| | Date of application | April 13, 2012 | |
| EUT | Type of device | Class B personal computers and peripherals | |
| | Equipment authorization | <input type="checkbox"/> Declaration of Conformity <input checked="" type="checkbox"/> Certification <input type="checkbox"/> Verification | |
| | FCC ID | A3LCLX3305FW | |
| | Kind of product | Laser MFP | |
| | Model No. | CLX-3305FW | |
| | | Variant Model No. | CLX-3300, CLX-3305, CLX-3306, CLX-3305N, CLX-3306N, CLX-3305W, CLX-3306W, CLX-3305FN, CLX-3306FN, CLX-3305FW, CLX-3306FW |
| | Manufacturer | Samsung Electronics Co., Ltd. 259, Gongdan-Dong, Gumi-City, Gyeongsangbuk-Do, Korea 730-030 Samsung Electronics (Shandong) Digital Printing Co., Ltd. 264209, Samsung Road, Weihai Hi-Tech. IDZ, Shandong Province, P.R.China Weihai Shin Heung Digital Electronics Co., Ltd. 98, Samsung Road, Weihai Hi-Tech. IDZ, Shandong Province, P.R.China Intops : Intops (Weihai) Electronics Co., Ltd. Keji Road-268-1 , Weihai Hi-Tech, Industries Development Zone , Shandong Province , CHINA | |
| Applied Standards | FCC Part 15, Subpart B / ANSI C63.4-2009 | | |
| Test Period | May 2, 2012 ~ May 3, 2012 | | |
| Issue date | May 3, 2012 | | |
| Test result : Complied | | | |
| The equipment under test has found to be compliant with the applied standards. The result is not applied the uncertainty concept. This mean that the result is applied the original (standard) limit. (Refer to the attached test result for more detail.) | | | |
| Tested by : Young Ju Ryu | | Reviewed by : Tae Young Jang | |
|  | |  | |
| The test results in this report only apply to the tested sample. This report must not be reproduced, except in full, without written permission from CS & Environment center. | | | |
|  | | | |
| 416 Maetan 3-Dong, Yeongtong-Gu, Suwon-Si, Gyeonggi-Do, 443-742 Korea Tel: 82 31 277 7752, Fax: 82 31 277 7753 | | | |

Table of contents

| | |
|--------------------------------------|-----------|
| 1. Report information | |
| 1.1 Revision history | - 3 page |
| 1.2 Sample calculation | - 3 page |
| 2. Summary of test results | |
| 2.1 Emission | - 3 page |
| 3. General Information | |
| 3.1 Test facility | - 4 page |
| 4. Test configuration | |
| 4.1 Test Peripherals | - 4 page |
| 4.2 EUT operating mode | - 5 page |
| 4.3 Details of Sampling | - 5 page |
| 4.4 Used cable description | - 5 page |
| 4.5 Test arrangement | - 6 page |
| 4.6 EUT Description | - 7 page |
| 4.7 Clock Frequencies | - 8 page |
| 4.8 Test configuration and condition | - 8 page |
| 4.9 Measurement uncertainty | - 9 page |
| 5. Result of individual tests | |
| 5.1 Conducted disturbance | - 10 page |
| 5.2 Radiated disturbance | - 18 page |

| | |
|-----------------------------------|-----------|
| Appendix – EUT photography | - 31 page |
|-----------------------------------|-----------|

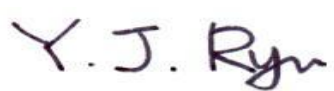
1. Report information

1.1 Revision history

| No. | Revised detailed information |
|---------|---|
| Issue 0 | There are no revisions and this version is basic test report. |

1.2 Sample calculation

1.2.1 Conducted disturbance (at 10 MHz)

- Class B limit = 60 dB μ V (Quasi-peak limit)
- Level (50 dB μ V) = Meter Reading (40.2 dB μ V) + factor (9.8 dB, AMN factor 9.7 dB + Cable loss 0.1 dB)
- Margin (10 dB) = Limit (60 dB μ V) – Level (50 dB μ V) = 10 dB below limit

1.2.2 Radiated disturbance (at 100 MHz)

- Class B limit = 30 dB μ V/m at 10 m
- Level (20 dB μ V/m)
 - = Meter Reading (40 dB μ V) + factor (- 20 dB (1/m), antenna factor + cable loss – amplifier gain)
- Margin (10 dB) = Limit (30 dB μ V/m) – Level (20 dB μ V/m) = 10 dB below limit

2. Summary of test results

2.1 Emission

The EUT has been tested according to the following specifications:

| Applied | Test type | Applied standard | Result |
|-------------------------------------|---------------------------------------|--|----------|
| <input checked="" type="checkbox"/> | Conducted Disturbance (Mains Port) | FCC Part 15 Subpart B / ANSI C63.4-2009 | Complied |
| <input checked="" type="checkbox"/> | Radiated Disturbance | | Complied |

3. General Information

3.1 Test facility

The CS & Environment center is located on Samsung Electronics Co., Ltd. at 416 Maetan 3-Dong, Yeongtong-Gu, Suwon-Si, Gyeonggi-Do, South Korea.

All testing are performed in Semi-anechoic chambers conforming to the site attenuation Characteristics defined by ANSI C63.4, CISPR 22, 16-1 and 16-2. and Shielded rooms.

The CS & Environment center is operated as testing laboratory in accordance with the requirements of ISO/IEC 17025:2005.

4. Test Setup configuration

4.1 Test Peripherals

The cables used for these peripherals are either permanently attached by the peripheral manufacturer or coupled with an assigned cable as defined below.

The following is a listing of the EUT and peripherals utilized during the performance of EMC test:

| Seq | Description | Model No. | Serial No. | Manufacturer | Fcc ID / DoC |
|-----|---------------------|------------|--------------------------|-----------------------|--------------|
| A | LASER MFP | CLX-3305FW | - | Samsung | EUT |
| B | PC | NT-P530 | ZSV293BZ600309F | Samsung | DoC |
| C | Adapter (For PC) | AD-6019R | CNBA4400242ABZ0415E0476 | Delta | DoC |
| D | USB Mouse | MOARUO | 0827010021 | PRIMAX electronics | DoC |
| E | Headset | - | - | ACTTO | - |
| F | Phone | SP-F131 | KKCW300489 | Nobita | - |
| G | Monitor | SP2208WFPt | CN-0PK977-71618-838-106S | DELL | DoC |
| H | USB Keyboard | SK-8115 | CN-0J4636-71616-641-0GIY | DELL | DoC |

4.2 EUT operating mode

To achieve compliance applied standard specification, the following mode(s) were made during compliance testing:

| | |
|-------------------------|----------|
| Operating Mode 1 | ADF copy |
| Operating Mode 2 | Fax TX |
| Operating Mode 3 | Stand by |

4.3 Details of Sampling

Customer selected, single unit.

4.4 Used cable description

The EUT is configured, installed, arranged and operated in a manner consistent with typical applications. Interface cables/loads/devices are connected to at least one of each type of interface port of the EUT, and where practical, each cable shall be terminated in a device typical of actual usage. The type(s) of interconnecting cables to be used and the interface port (of the EUT) to which these were connected;

| No. | Connected cable | Length [m] | Shielded [Y/N] | Note |
|-----|-----------------|------------|----------------|-----------------------------|
| 1 | Power | 1.5 | No | For EUT |
| 2 | Power | 1.0 | No | For PC |
| 3 | USB | 1.8 | Yes | From EUT to PC |
| 4 | LAN | 2.0 | No | From EUT to HUB |
| 5 | USB | 1.0 | Yes | From PC to Mouse |
| 6 | Headset | 1.0 | No | From PC to Headset |
| 7 | TEL | 1.5 | No | From EUT to telephones |
| 8 | TEL | 2.0 | No | From EUT to keyphone system |
| 9 | USB | 1.0 | Yes | From PC to Keyboard |
| 10 | RGB | 1.5 | Yes | From PC to Monitor |
| 11 | HDMI | 1.5 | Yes | From PC to Monitor |
| 12 | Power | 1.5 | No | For Monitor |

4.5 Test arrangement

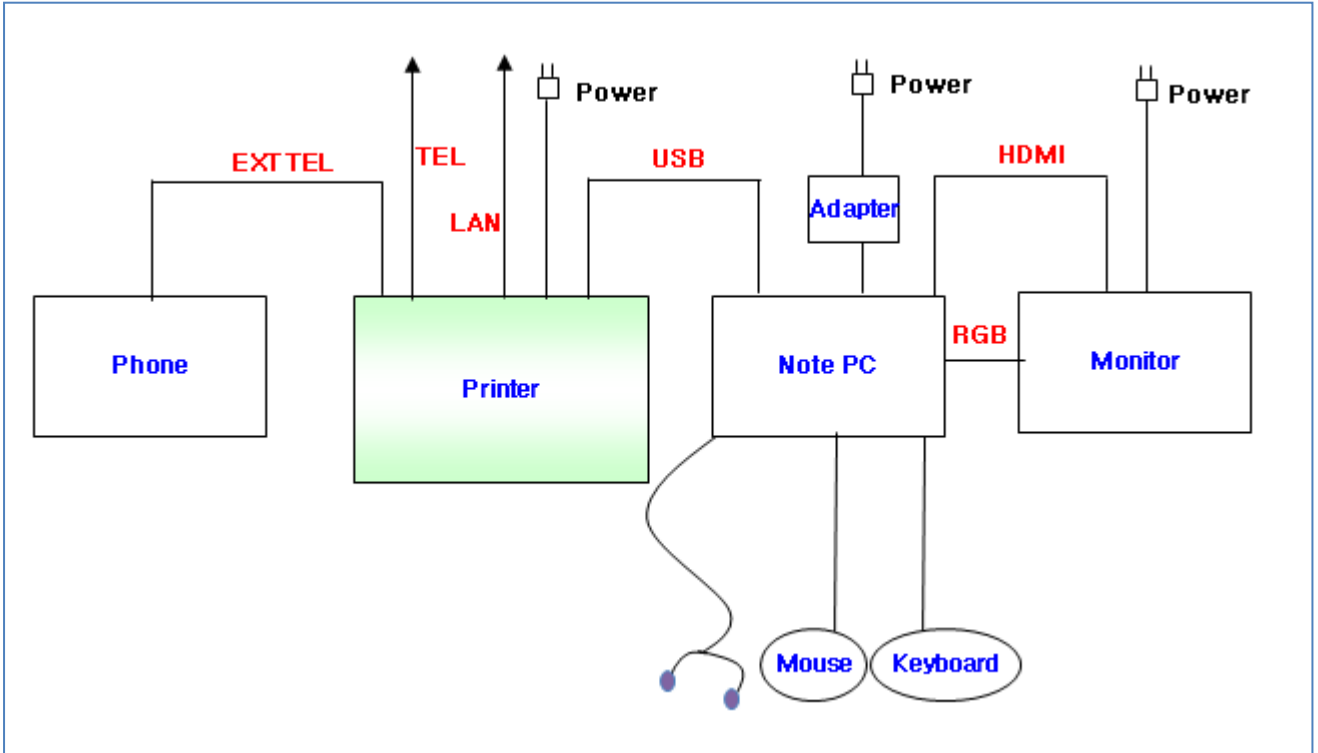

4.6 EUT Description

The following features describe EUT represented by this report:

| Item | Specification and Description |
|-------------------------------------|---|
| Processor | CHORUS3N (533Mhz, ARM1176) |
| Standard System memory | 128MB DDR3 |
| Resolution | Best 600x600dpi 2bit Normal 600x600dpi 1bit |
| Copy Quality mode | Text : 600x600dpi(ADF) ,600x600dpi (Platen) Mixed : 600x600dpi(ADF) ,600x600dpi (Platen) Photo : 600x600dpi(ADF) ,600x600dpi (Platen) |
| Paper Handling | Paper Tray(standard) 130 Sheets |
| Power Rating | 110~127VAC, 6A |
| Power Consumption | Power save mode : 2Watts Stand by mode : 60Watts Printing simplex : 850Watts ADF Copy mode : 850Watts |
| Printer Language | SPL-B,PCL-5c/6,PS3,URF |
| Interfaces | USB2.0, Network, FAX, Wireless |
| OS compatibility | Windows 95/98/2000/NT4.0/Win-ME/XP/Longhorn/XP 64bit/ Citrix MAC OS 8, 9, X 10.2, X 10.3 & Higher Unix/Linux |
| Modes of Operation | USB Printing, ADF Scan, Duplex ADF Copy, 1200dpi Printing, Fax RX, Fax TX, Network Printing, Duplex Printing, PC Scan NET Scan, Wireless Printing |
| Intended Class for Emissions | Class B |

4.7 Clock Frequencies

| Kind of Clocks | Frequency[MHz] | Kind of Clocks | Frequency[MHz] |
|---------------------------|----------------|-------------------|----------------|
| CPU internal clock | 533 | DDR3 clock | 366 |
| Network | 25 | Main source clock | 12 |
| USB device clock | 12 | Video clock | 12 |

4.8 Test configuration and condition

The system was configured for testing in typical fashion use. Cables were attached to each of the available I/O Ports. Where applicable, peripherals were attached to the I/O cables. The mode of operation utilized for testing was selected to best simulate typical EUT use.

The EUT was measured all testing with toner cartridge.

- Test Voltage : AC 120 V, 60 Hz

4.9 Measurement uncertainty

Where relevant, the following measurement uncertainty levels have been estimated for tests performed on the apparatus: (According to CISPR 16-4 and UKAS Lab 34.)

4.9.1 Emission

| Test type | | Measurement uncertainty (C.L. 95 %, k = 2) |
|---------------------------------------|---------------|---|
| Conducted disturbance | Main terminal | 3.30 dB |
| Radiated Disturbance (Below 1 GHz) | Horizontal | 5.26 dB |
| | Vertical | 5.27 dB |
| Radiated Disturbance (Above 1 GHz) | Horizontal | 3.40 dB |
| | Vertical | 3.12 dB |

5. Results of individual test

5.1 Conducted disturbance

Both conducted lines are measured in Quasi-Peak and Average mode, including the worst-case data points for each tested configuration. The EUT measured in accordance with the methods described in standards.

Limits for conducted disturbance at the mains ports of class B ITE

| Frequency range Limits MHz | Resolution Bandwidth | Limits dB μ V | |
|-------------------------------|----------------------|-------------------|----------|
| | | Quasi-peak | Average |
| 0.15 to 0.50 | 9 kHz | 66 to 56 | 56 to 46 |
| 0.50 to 5 | 9 kHz | 56 | 46 |
| 5 to 30 | 9 kHz | 60 | 50 |

NOTE 1 The lower limit shall apply at the transition frequency
 NOTE 2 The limit decreases linearly with the logarithm of the frequency in the range 0.15 MHz to 0.50 MHz.

5.1.1 Test instrumentation

| Test instrumentation | Model name | Manufacturer | Serial or Firmware (No./Ver.) | Calibration | |
|--------------------------|------------|--------------|----------------------------------|-------------|---------------------|
| | | | | Date | Interval (Month) |
| Measuring receiver | ESU 08 | R&S | 100085 | 2012-03-23 | 12 |
| Artificial mains network | ENV216 | R&S | 100456 | 2011-09-28 | 12 |
| Artificial mains network | ESH3-Z5 | R&S | 831887/004 | 2011-07-27 | 12 |
| Test Software | EMC32 | R&S | Ver 5.20.1 | - | - |

5.1.2 Temperature and humidity condition

| | | | | | |
|-------------------|----------------------|---------------|-------------------|------|--|
| Test date | May 2, 2012 | Test engineer | Young Ju Ryu | | |
| Climate condition | Ambient temperature | 22.5 °C | Relative humidity | 30 % | |
| | Atmospheric pressure | 100.3 kPa | | | |
| Test place | Shielded Room #1 | | | | |

5.1.3 Photograph of Test Setup



Front



Rear

5.1.4 Test results (mains port)

- ADF copy mode

Hardware Setup: Voltage with ENV 2-Line-LISN - [EMI conducted]

Subrange 1
 Frequency Range: 150 kHz – 30 MHz
 Receiver: ESU 8
 Transducer: ENV216 / Receiver-2-Line-LISN ENV216

Scan Setup: B_ENV 2-Line-LISN fin [EMI conducted]

Hardware Setup: Voltage with ENV 2-Line-LISN
 Level Unit: dB μ V

| Subrange | Detectors | IF Bandwidth | Meas. Time | Receiver |
|------------------|---------------------|--------------|------------|----------|
| 150 kHz – 30 MHz | Quasi Peak; Average | 9 kHz | 15 s | ESU 8 |

Test Graph

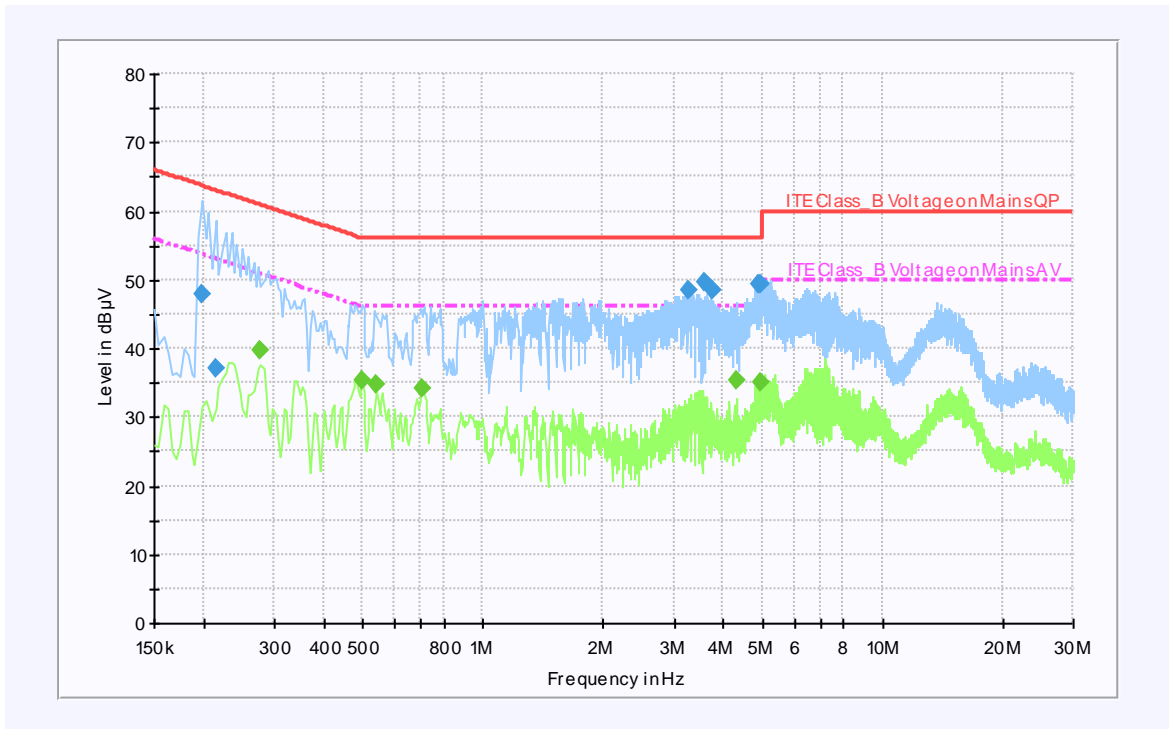

Note) Two graphs measured for both Live(L1) and Neutral(N) of the LISN are combined into one graph.

Test Results (Quasi-Peak and Average)

Quasi-peak final measurement results table

| Frequency (MHz) | Quasi-Peak (dB μ V) | Line | Corr. (dB) | Margin (dB) | Limit (dB μ V) |
|-----------------|-------------------------|------|------------|-------------|--------------------|
| 0.198 | 47.8 | N | 9.7 | 15.9 | 63.7 |
| 0.214 | 37.2 | N | 9.7 | 25.8 | 63.0 |
| 3.256 | 48.3 | N | 9.7 | 7.7 | 56.0 |
| 3.568 | 49.6 | N | 9.7 | 6.4 | 56.0 |
| 3.776 | 48.6 | N | 9.7 | 7.4 | 56.0 |
| 4.884 | 49.3 | N | 9.7 | 6.7 | 56.0 |
| 4.980 | 49.4 | N | 9.7 | 6.6 | 56.0 |

Average final measurement results table

| Frequency (MHz) | Average (dB μ V) | Line | Corr. (dB) | Margin (dB) | Limit (dB μ V) |
|-----------------|----------------------|------|------------|-------------|--------------------|
| 0.278 | 39.9 | N | 9.7 | 11.0 | 50.9 |
| 0.498 | 35.3 | N | 9.7 | 10.7 | 46.0 |
| 0.542 | 34.8 | N | 9.7 | 11.2 | 46.0 |
| 0.702 | 34.3 | L1 | 9.7 | 11.7 | 46.0 |
| 4.308 | 35.4 | N | 9.7 | 10.6 | 46.0 |
| 4.940 | 35.0 | N | 9.7 | 11.0 | 46.0 |

Note) Level (Quasi-Peak and/or Average) = Meter Reading (Quasi-Peak and/or Average) + Factor (LISN Insertion Loss + Cable Loss)

Margin = Limit – Level (Quasi-Peak and/or Average)

- Fax TX mode

Hardware Setup: Voltage with ENV 2-Line-LISN - [EMI conducted]

Subrange 1
 Frequency Range: 150 kHz – 30 MHz
 Receiver: ESU 8
 Transducer: ENV216 / Receiver-2-Line-LISN ENV216

Scan Setup: B_ENV 2-Line-LISN fin [EMI conducted]

Hardware Setup: Voltage with ENV 2-Line-LISN
 Level Unit: dB μ V

| Subrange | Detectors | IF Bandwidth | Meas. Time | Receiver |
|------------------|---------------------|--------------|------------|----------|
| 150 kHz – 30 MHz | Quasi Peak; Average | 9 kHz | 15 s | ESU 8 |

Test Graph

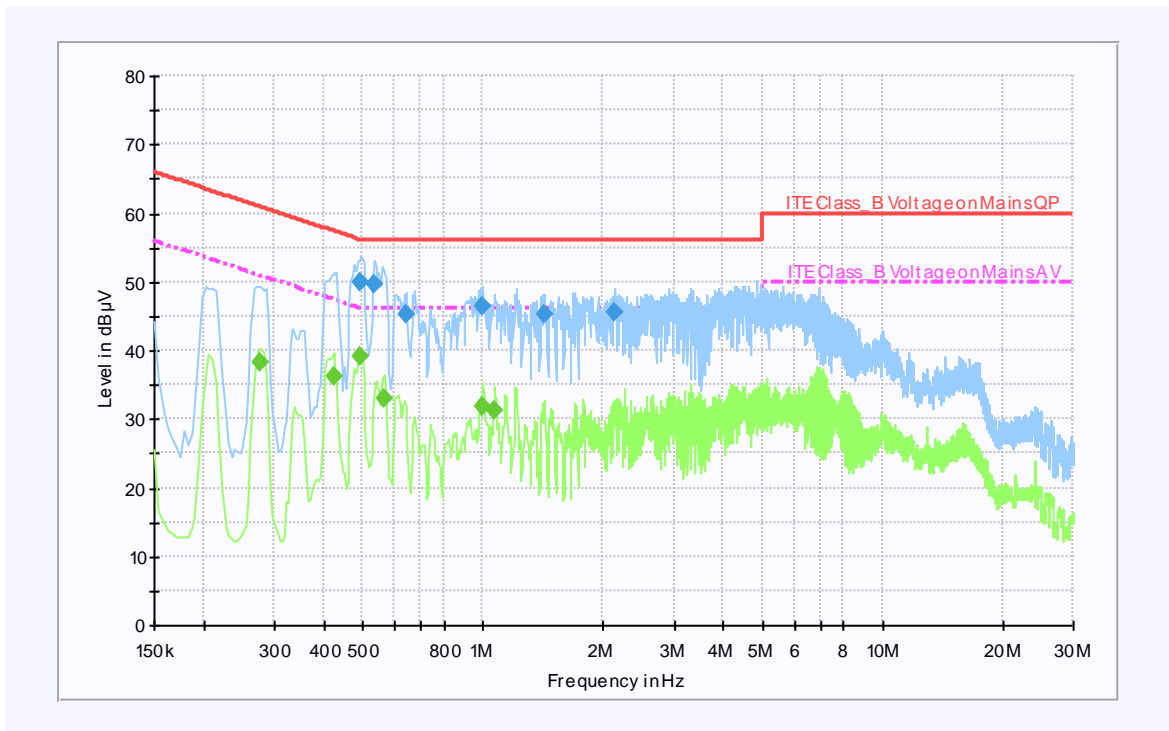

Note) Two graphs measured for both Live(L1) and Neutral(N) of the LISN are combined into one graph.

Test Results (Quasi-Peak and Average)

Quasi-peak final measurement results table

| Frequency (MHz) | Quasi-Peak (dB μ V) | Line | Corr. (dB) | Margin (dB) | Limit (dB μ V) |
|-----------------|-------------------------|------|------------|-------------|--------------------|
| 0.494 | 49.9 | L1 | 9.7 | 6.2 | 56.1 |
| 0.534 | 49.7 | L1 | 9.7 | 6.3 | 56.0 |
| 0.642 | 45.4 | L1 | 9.7 | 10.6 | 56.0 |
| 1.000 | 46.5 | L1 | 9.7 | 9.5 | 56.0 |
| 1.428 | 45.3 | L1 | 9.7 | 10.7 | 56.0 |
| 2.144 | 45.5 | L1 | 9.7 | 10.5 | 56.0 |

Average final measurement results table

| Frequency (MHz) | Average (dB μ V) | Line | Corr. (dB) | Margin (dB) | Limit (dB μ V) |
|-----------------|----------------------|------|------------|-------------|--------------------|
| 0.278 | 38.2 | L1 | 9.7 | 12.7 | 50.9 |
| 0.422 | 36.3 | N | 9.7 | 11.1 | 47.4 |
| 0.494 | 39.2 | L1 | 9.7 | 6.9 | 46.1 |
| 0.566 | 32.9 | N | 9.7 | 13.1 | 46.0 |
| 1.000 | 31.9 | L1 | 9.7 | 14.1 | 46.0 |
| 1.068 | 31.4 | L1 | 9.7 | 14.6 | 46.0 |

Note) Level (Quasi-Peak and/or Average) = Meter Reading (Quasi-Peak and/or Average) + Factor (LISN Insertion Loss + Cable Loss)

Margin = Limit – Level (Quasi-Peak and/or Average)

- Stand-by mode

Hardware Setup: Voltage with ENV 2-Line-LISN - [EMI conducted]

Subrange 1

Frequency Range: 150 kHz – 30 MHz
 Receiver: ESU 8
 Transducer: ENV216 / Receiver-2-Line-LISN ENV216

Scan Setup: B_ENV 2-Line-LISN fin [EMI conducted]

Hardware Setup: Voltage with ENV 2-Line-LISN
 Level Unit: dB μ V

| Subrange | Detectors | IF Bandwidth | Meas. Time | Receiver |
|------------------|---------------------|--------------|------------|----------|
| 150 kHz – 30 MHz | Quasi Peak; Average | 9 kHz | 15 s | ESU 8 |

Test Graph

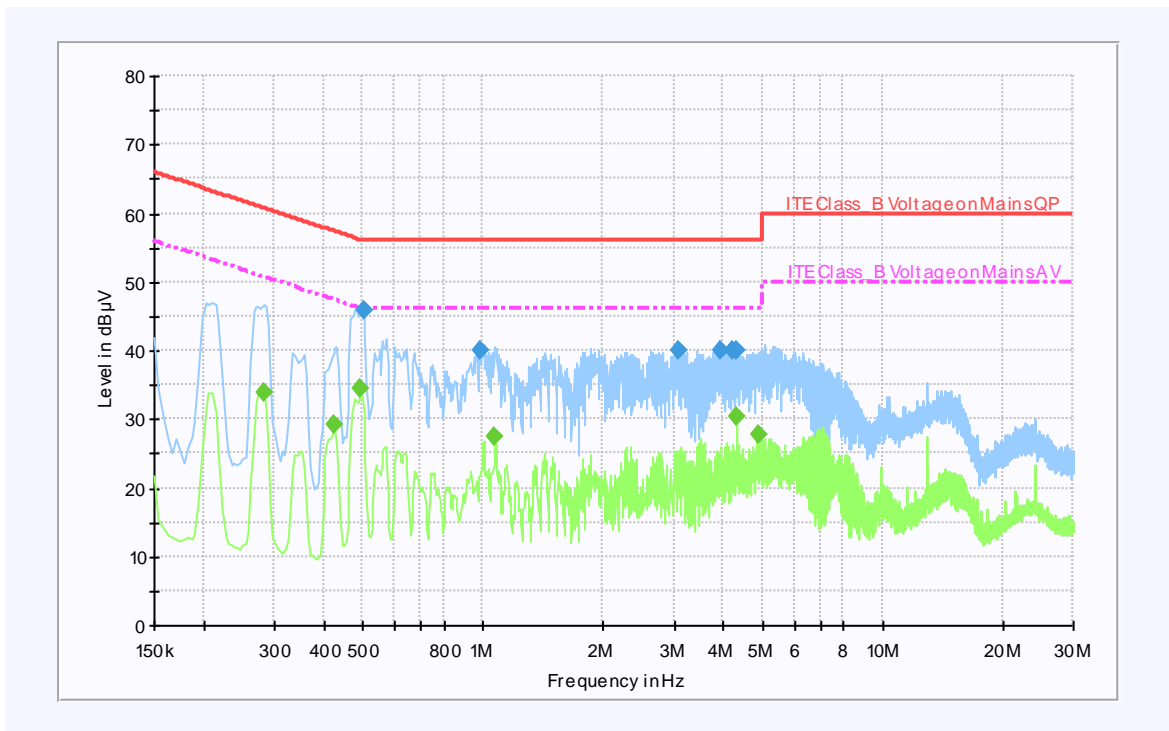

Note) Two graphs measured for both Live(L1) and Neutral(N) of the LISN are combined into one graph.

Test Results (Quasi-Peak and Average)

Quasi-peak final measurement results table

| Frequency (MHz) | Quasi-Peak (dB μ V) | Line | Corr. (dB) | Margin (dB) | Limit (dB μ V) |
|-----------------|-------------------------|------|------------|-------------|--------------------|
| 0.502 | 45.9 | N | 9.7 | 10.1 | 56.0 |
| 0.986 | 40.1 | N | 9.7 | 15.9 | 56.0 |
| 3.080 | 39.9 | N | 9.7 | 16.1 | 56.0 |
| 3.940 | 40.0 | N | 9.7 | 16.0 | 56.0 |
| 4.228 | 40.0 | N | 9.7 | 16.0 | 56.0 |
| 4.300 | 40.1 | N | 9.7 | 15.9 | 56.0 |

Average final measurement results table

| Frequency (MHz) | Average (dB μ V) | Line | Corr. (dB) | Margin (dB) | Limit (dB μ V) |
|-----------------|----------------------|------|------------|-------------|--------------------|
| 0.282 | 33.9 | N | 9.7 | 16.9 | 50.8 |
| 0.426 | 29.2 | N | 9.7 | 18.1 | 47.3 |
| 0.494 | 34.3 | N | 9.7 | 11.8 | 46.1 |
| 1.072 | 27.6 | N | 9.7 | 18.4 | 46.0 |
| 4.308 | 30.3 | N | 9.7 | 15.7 | 46.0 |
| 4.884 | 27.6 | N | 9.7 | 18.4 | 46.0 |

Note) Level (Quasi-Peak and/or Average) = Meter Reading (Quasi-Peak and/or Average) + Factor (LISN Insertion Loss + Cable Loss)

Margin = Limit – Level (Quasi-Peak and/or Average)

5.2 Radiated disturbance

Of those disturbances above ($L - 20\text{dB}$), where L is the limit level in logarithmic units, record at least the disturbance levels and the frequencies of the six highest disturbances.

The following data lists the significant emission frequencies, measured levels, correction factors (for antenna and cables), orientation of table, polarization and height of antenna, the corrected reading, the limit, and the amount of margin.

All measurements were taken utilizing quasi-peak detection unless stated otherwise.

Measurements were performed at an antenna to EUT distance of 10 m and elevated between 1 m and 4 m.

Both vertical and horizontal antenna polarizations were measured.

Above GHz, peak detector function mode was used with resolution bandwidth of 1 MHz and a video bandwidth of 1 MHz.

If the peak measured value complies with the average limit, it is unnecessary to perform an average measurement.

Limits for radiated disturbance of ITE at a measuring distance of 10 m

| Frequency range Limits MHz | Resolution Bandwidth | Quasi-peak Limits dB μ V/m |
|---|----------------------|--------------------------------|
| | | Class B |
| 30 to 230 | 120 kHz | 30 |
| 230 to 1000 | 120 kHz | 37 |
| NOTE 1 The lower limit shall apply at the transition frequency | | |
| NOTE 2 Additional provisions may be required for cases where interference occurs. | | |

Peak measurements were made over the changeable frequency range 1 GHz to 6 GHz in accordance with internal maximum operating frequency at a measurement distance of 3 m for the following antenna and turntable arrangements:

| Antenna Height (cm) | Antenna Polarisation | Turntable position (degrees) |
|----------------------|----------------------|------------------------------|
| 100 ~ 400 | Horizontal, Vertical | Continuous |

Above 1 GHz, peak detector function mode is used with a resolution bandwidth of 1 MHz and a video bandwidth of 1 MHz.

Limits for above 1GHz radiated disturbance of ITE at a measuring distance of 3 m

| Class | Limits - dB(μ V/m) | |
|--|-------------------------|---------|
| | Peak | Average |
| B | 74 | 54 |
| Average limit 500, $20 \log 500 = 53.979 \text{ dB} \approx 54 \text{ dB}$ | | |

Antenna height was adjusted to maximum radiated position to be parallel from EUT to antenna centre.

Measurements within 20 dB of the limit were then maximized by adjusting turntable position.

Final measurements were made using a average detector.

Results checked manually; and points close to the limit line were re-measured.

5.2.1 Test instrumentation

| Test instrumentation | Model name | Manufacturer | Serial or Firmware (No./Ver.) | Calibration | |
|----------------------|------------|--------------|-------------------------------|-------------|------------------|
| | | | | Date | Interval (Month) |
| EMI Test Receiver | ESU | R&S | 100084 | 2011-10-10 | 12 |
| EMI Test Receiver | ESCI | R&S | 100370 | 2011-05-29 | 12 |
| Bi-log Antenna | CBL6112D | SCHAFFNER | 22248 | 2012-02-16 | 24 |
| Bi-log Antenna | CBL6112D | SCHAFFNER | 27627 | 2011-10-07 | 24 |
| Amplifier | 310N | SONOMA | 251673 | 2011-12-19 | 12 |
| Amplifier | 310N | SONOMA | 251675 | 2012-01-31 | 12 |
| Ant. Mast | MA4000 | inn-co | - | - | - |
| Ant. Mast | MA4000 | inn-co | - | - | - |
| Mast Controller | CO2000 | inn-co | - | - | - |
| RF selector | NS4900 | TOYO | - | - | - |
| EMI Test Receiver | ESIB | R&S | 832672/002 | 2011-11-11 | 12 |
| Horn antenna | HF907 | R&S | 100016 | 2011-06-15 | 24 |
| Preamplifier | SCU18 | R&S | 10001 | 2011-05-03 | 12 |
| Test Software | EP5/RE | TOYO | Ver 3.10.20 | - | - |

5.2.2 Temperature and humidity condition

| | | | | |
|--------------------------|-----------------------------|----------------------|--------------------------|------|
| Test date | May 3, 2012 | Test engineer | Young Ju Ryu | |
| Climate condition | Ambient temperature | 22.3 °C | Relative humidity | 30 % |
| | Atmospheric pressure | 100.5 kPa | | |
| Test place | 10 m Semi-Anechoic Chamber | | | |

5.2.3 Photograph of Test Setup

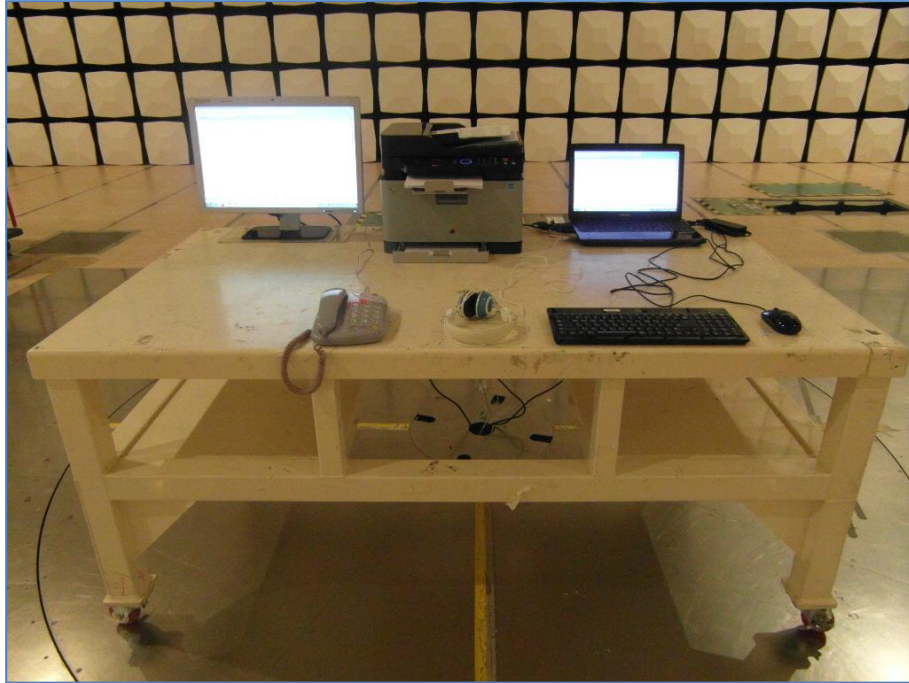

Front (Below 1GHz)

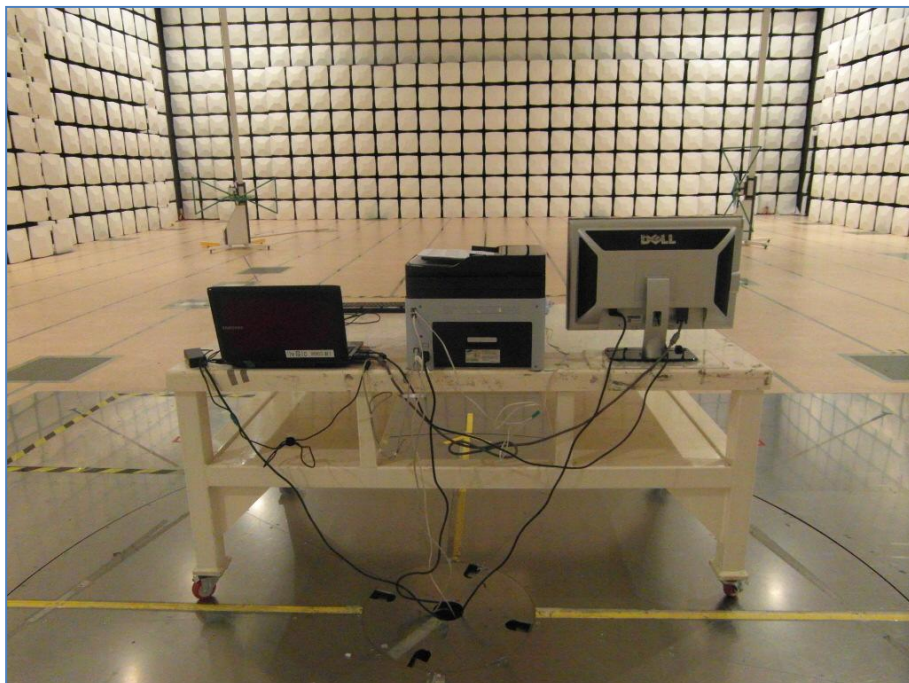

Rear (Below 1GHz)

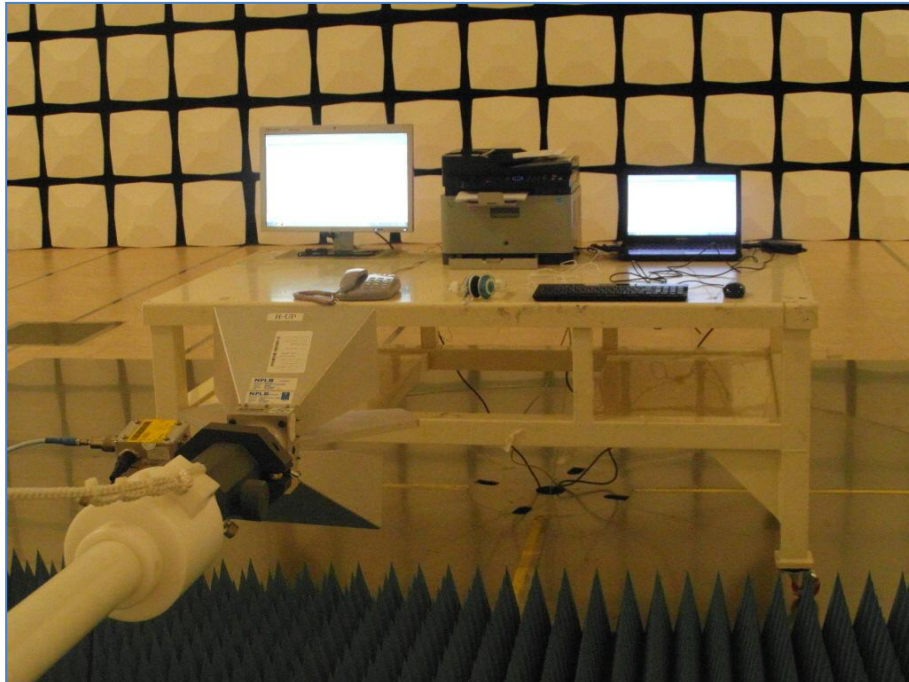

Front (above 1GHz)



Rear (above 1GHz)

5.2.4 Test results

5.2.4.1 30 MHz to 1GHz test results

- ADF copy Mode

Test Graph and Results

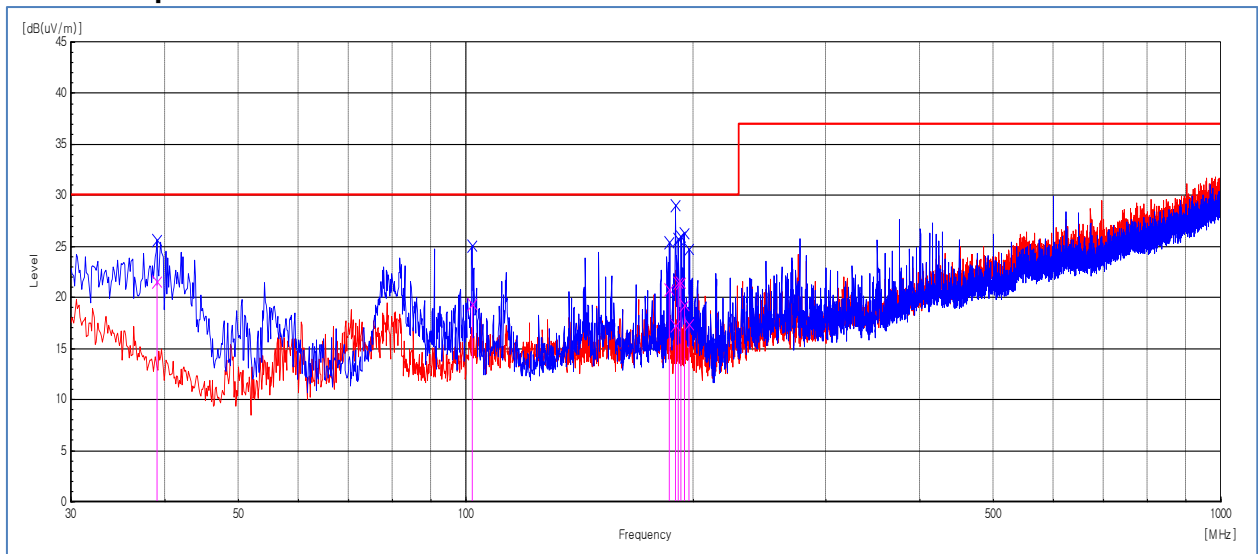

| Frequency [MHz] | Pol. | Reading QP [dB(μV)] | Factor [dB(1/m)] | Level QP [dB(μV /m)] | Limit [dB(μV /m)] | Margin QP [dB] | Height [cm] | Angle [deg] |
|-----------------|------|---------------------|------------------|----------------------|-------------------|----------------|-------------|-------------|
| 38.973 | V | 39.7 | -18.1 | 21.6 | 30 | 8.4 | 102 | 176.1 |
| 101.901 | V | 37.6 | -18.2 | 19.4 | 30 | 10.6 | 169 | 56 |
| 186.17 | V | 40.4 | -19.6 | 20.8 | 30 | 9.2 | 164 | 1.1 |
| 189.565 | V | 36.9 | -19.6 | 17.3 | 30 | 12.7 | 110 | 1.1 |
| 191.141 | V | 41.2 | -19.7 | 21.5 | 30 | 8.5 | 397 | 23.7 |
| 192.839 | V | 41.1 | -19.7 | 21.4 | 30 | 8.6 | 253 | 1.1 |
| 194.536 | V | 39 | -19.7 | 19.3 | 30 | 10.7 | 348 | 2.3 |
| 197.689 | V | 37.2 | -19.8 | 17.4 | 30 | 12.6 | 101 | 32.7 |

Note) Receiving antenna polarization : Horizontal and/or Vertical

Test Distance : 10 m, Antenna Height : 1 m to 4 m

Level QP (Quasi-Peak) = Reading QP + Factor (Antenna Factor + Cable Loss - Amp. Gain)

Margin QP (Quasi-Peak) = Limit – Level QP

- Fax TX Mode

Test Graph and Results

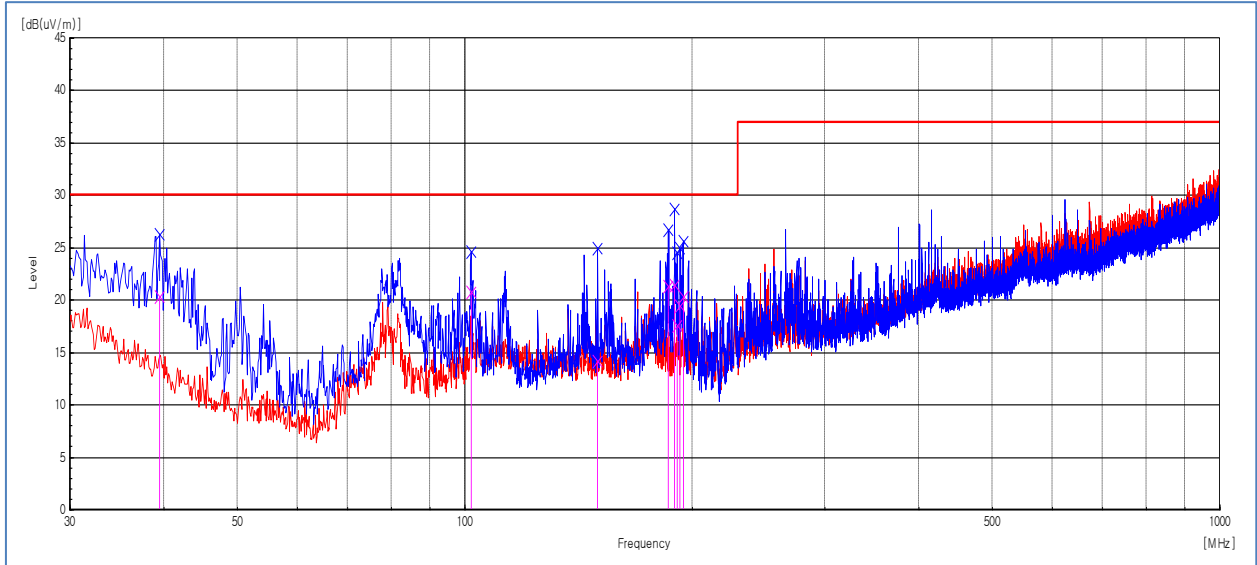

| Frequency [MHz] | Pol. | Reading QP [dB(μV)] | Factor [dB(1/m)] | Level QP [dB(μV /m)] | Limit [dB(μV /m)] | Margin QP [dB] | Height [cm] | Angle [deg] |
|-----------------|------|---------------------|------------------|----------------------|-------------------|----------------|-------------|-------------|
| 39.458 | V | 38.8 | -18.4 | 20.4 | 30 | 9.6 | 103 | 358.9 |
| 101.901 | V | 39 | -18.2 | 20.8 | 30 | 9.2 | 112 | 33.6 |
| 149.916 | V | 32.3 | -18.1 | 14.2 | 30 | 15.8 | 139 | 15.2 |
| 186.17 | V | 40.9 | -19.6 | 21.3 | 30 | 8.7 | 257 | 355.9 |
| 189.565 | V | 41 | -19.6 | 21.4 | 30 | 8.6 | 346 | 352.2 |
| 191.141 | V | 37.3 | -19.7 | 17.6 | 30 | 12.4 | 109 | 354.9 |
| 192.839 | V | 39.2 | -19.7 | 19.5 | 30 | 10.5 | 102 | 358.9 |
| 194.536 | V | 40 | -19.7 | 20.3 | 30 | 9.7 | 101 | 10.7 |

Note) Receiving antenna polarization : Horizontal and/or Vertical

Test Distance : 10 m, Antenna Height : 1 m to 4 m

Level QP (Quasi-Peak) = Reading QP + Factor (Antenna Factor + Cable Loss - Amp. Gain)

Margin QP (Quasi-Peak) = Limit – Level QP

- Stand-by Mode

Test Graph and Results

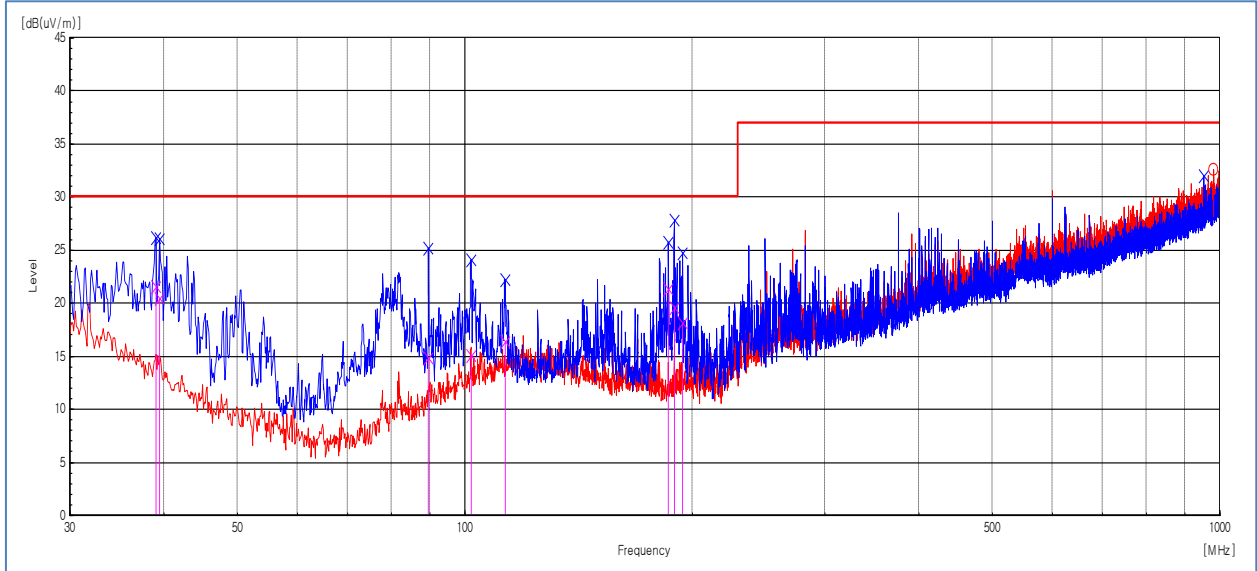

| Frequency [MHz] | Pol. | Reading QP [dB(μV)] | Factor [dB(1/m)] | Level QP [dB(μV /m)] | Limit [dB(μV /m)] | Margin QP [dB] | Height [cm] | Angle [deg] |
|-----------------|------|---------------------|------------------|----------------------|-------------------|----------------|-------------|-------------|
| 38.973 | V | 39.7 | -18.1 | 21.6 | 30 | 8.4 | 102 | 128.4 |
| 39.458 | V | 38.9 | -18.4 | 20.5 | 30 | 9.5 | 115 | 355.3 |
| 89.534 | V | 35.4 | -20.5 | 14.9 | 30 | 15.1 | 109 | 63.1 |
| 101.901 | V | 33.3 | -18.2 | 15.1 | 30 | 14.9 | 100 | 2.8 |
| 113.056 | V | 33.8 | -17.4 | 16.4 | 30 | 13.6 | 257 | 118.9 |
| 186.049 | V | 40.9 | -19.6 | 21.3 | 30 | 8.7 | 348 | 358.3 |
| 189.323 | V | 39.2 | -19.6 | 19.6 | 30 | 10.4 | 201 | 0.8 |
| 194.294 | V | 37.8 | -19.7 | 18.1 | 30 | 11.9 | 165 | 357.3 |

Note) Receiving antenna polarization : Horizontal and/or Vertical

Test Distance : 10 m, Antenna Height : 1 m to 4 m

Level QP (Quasi-Peak) = Reading QP + Factor (Antenna Factor + Cable Loss - Amp. Gain)

Margin QP (Quasi-Peak) = Limit – Level QP

5.2.4.2 1 GHz to 6 GHz test results

- ADF copy Mode

Test Results

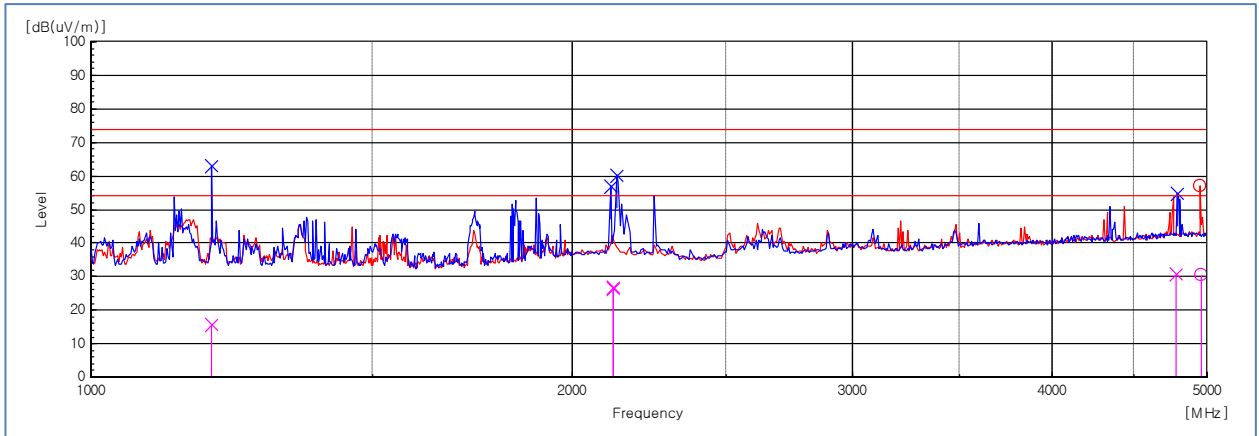

Peak Measurement

| Frequency [MHz] | POL | Reading PK [dB(uV)] | Factor [dB(1/m)] | Level PK [dB(uV/m)] | Limit [dB(uV/m)] | Margin PK [dB] | Height [cm] | Angle [deg] |
|-----------------|-----|---------------------|------------------|---------------------|------------------|----------------|-------------|-------------|
| 1190.381 | V | 73.3 | -10.3 | 63 | 74 | 11 | 108 | 142.6 |
| 2114.229 | V | 61.9 | -5.1 | 56.8 | 74 | 17.2 | 108 | 227.3 |
| 2132.265 | V | 65.4 | -5.1 | 60.3 | 74 | 13.7 | 108 | 227.3 |
| 4789.579 | V | 52.2 | 2.6 | 54.8 | 74 | 19.2 | 108 | 46 |
| 4951.904 | H | 54.2 | 2.6 | 56.8 | 74 | 17.2 | 108 | 333.2 |

Average Measurement

| Frequency [MHz] | POL | Reading AV [dB(uV)] | Factor [dB(1/m)] | Level AV [dB(uV/m)] | Limit [dB(uV/m)] | Margin AV [dB] | Height [cm] | Angle [deg] |
|-----------------|-----|---------------------|------------------|---------------------|------------------|----------------|-------------|-------------|
| 1189.98 | V | 26.2 | -10.3 | 15.9 | 54 | 38.1 | 108 | 143.2 |
| 2122.766 | V | 31.9 | -5.1 | 26.8 | 54 | 27.2 | 108 | 226.7 |
| 2123.066 | V | 31.7 | -5.1 | 26.6 | 54 | 27.4 | 108 | 226.7 |
| 4777.916 | V | 28.2 | 2.5 | 30.7 | 54 | 23.3 | 108 | 46.6 |
| 4960.382 | H | 28 | 2.6 | 30.6 | 54 | 23.4 | 108 | 332.6 |

Note 1) Representative operating modes were selected by customer and any emissions that do NOT exceed Average limit were not tested with average detector mode.

Note 2) Receiving antenna polarization : Horizontal and Vertical

Level PK (Peak) = Reading PK (Peak) + Factor (Antenna Factor + Cable Loss - Amp. Gain)

Level AV (Average) = Reading AV (Average) + Factor (Antenna Factor + Cable Loss - Amp. Gain)

Margin PK (Peak) = Limit – Level PK (Peak)

Margin AV (Average) = Limit – Level AV (Average)

- Fax TX Mode

Test Results

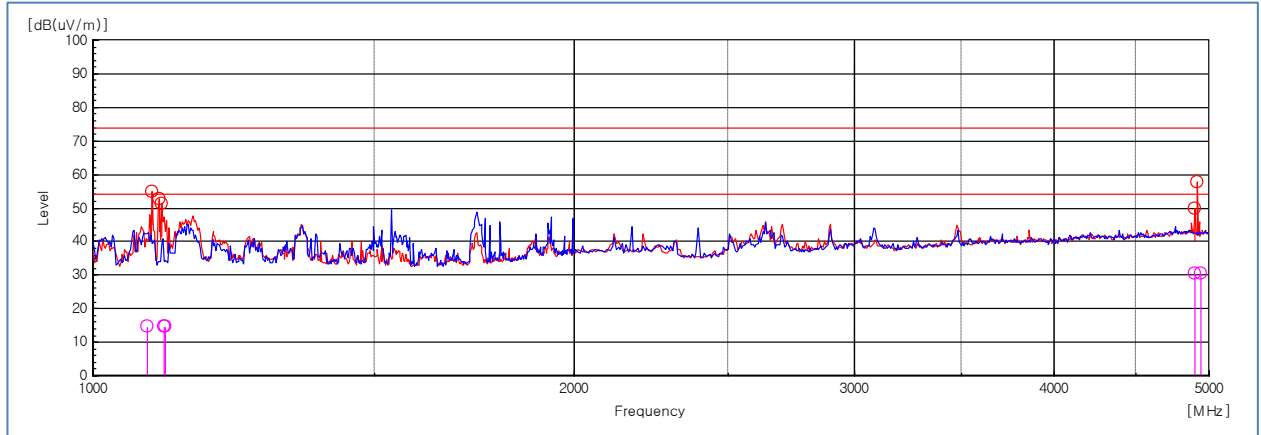

Peak Measurement

| Frequency [MHz] | POL | Reading PK [dB(uV)] | Factor [dB(1/m)] | Level PK [dB(uV/m)] | Limit [dB(uV/m)] | Margin PK [dB] | Height [cm] | Angle [deg] |
|-----------------|-----|---------------------|------------------|---------------------|------------------|----------------|-------------|-------------|
| 1088.176 | H | 65.7 | -10.7 | 55 | 74 | 19 | 108 | 269 |
| 1100.2 | H | 63.2 | -10.7 | 52.5 | 74 | 21.5 | 108 | 269 |
| 1104.208 | H | 62 | -10.7 | 51.3 | 74 | 22.7 | 108 | 269 |
| 4897.796 | H | 47.4 | 2.6 | 50 | 74 | 24 | 108 | 349.8 |
| 4915.832 | H | 55.1 | 2.6 | 57.7 | 74 | 16.3 | 108 | 349.8 |

Average Measurement

| Frequency [MHz] | POL | Reading AV [dB(uV)] | Factor [dB(1/m)] | Level AV [dB(uV/m)] | Limit [dB(uV/m)] | Margin AV [dB] | Height [cm] | Angle [deg] |
|-----------------|-----|---------------------|------------------|---------------------|------------------|----------------|-------------|-------------|
| 1081.343 | H | 25.6 | -10.8 | 14.8 | 54 | 39.2 | 108 | 269.5 |
| 1106.833 | H | 25.5 | -10.7 | 14.8 | 54 | 39.2 | 108 | 269.5 |
| 1109.478 | H | 25.3 | -10.6 | 14.7 | 54 | 39.3 | 108 | 269.5 |
| 4900.622 | H | 28 | 2.6 | 30.6 | 54 | 23.4 | 108 | 349.2 |
| 4936.273 | H | 28 | 2.6 | 30.6 | 54 | 23.4 | 108 | 349.2 |

Note 1) Representative operating modes were selected by customer and any emissions that do NOT exceed Average limit were not tested with average detector mode.

Note 2) Receiving antenna polarization : Horizontal and Vertical

Level PK (Peak) = Reading PK (Peak) + Factor (Antenna Factor + Cable Loss - Amp. Gain)

Level AV (Average) = Reading AV (Average) + Factor (Antenna Factor + Cable Loss - Amp. Gain)

Margin PK (Peak) = Limit – Level PK (Peak)

Margin AV (Average) = Limit – Level AV (Average)

- Stand-by Mode

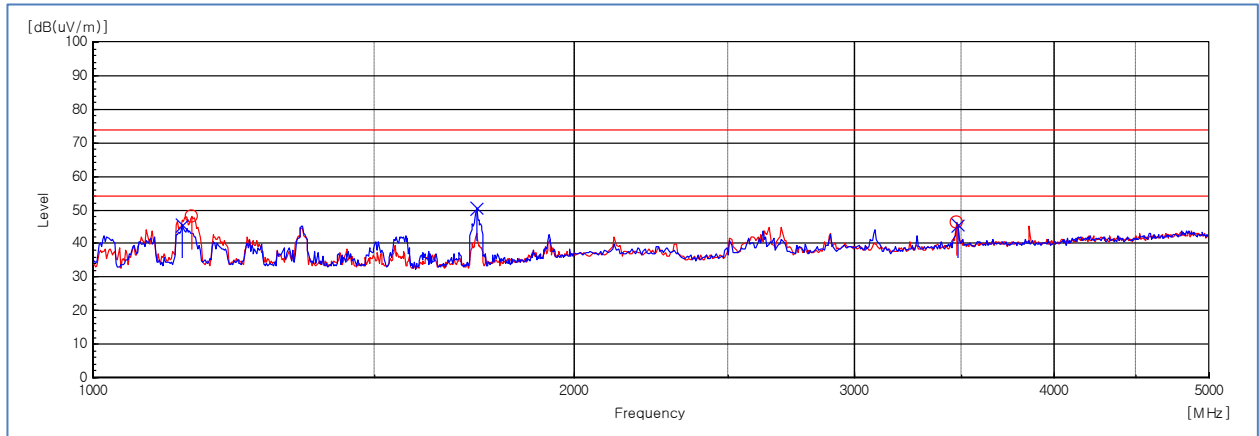
Test Results**Peak Measurement**

| Frequency [MHz] | POL | Reading PK [dB(uV)] | Factor [dB(1/m)] | Level PK [dB(uV/m)] | Limit [dB(uV/m)] | Margin PK [dB] | Height [cm] | Angle [deg] |
|-----------------|-----|---------------------|------------------|---------------------|------------------|----------------|-------------|-------------|
| 1136.273 | V | 56 | -10.5 | 45.5 | 74 | 28.5 | 108 | 356 |
| 1152.305 | H | 58.7 | -10.5 | 48.2 | 74 | 25.8 | 108 | 151.9 |
| 1739.479 | V | 59 | -8.4 | 50.6 | 74 | 23.4 | 108 | 180.5 |
| 3472.946 | H | 48 | -1.6 | 46.4 | 74 | 27.6 | 108 | 176.9 |
| 3478.958 | V | 47.2 | -1.6 | 45.6 | 74 | 28.4 | 108 | 149.5 |

Note 1) Representative operating modes were selected by customer and any emissions that do NOT exceed Average limit were not tested with average detector mode.

Note 2) Receiving antenna polarization : Horizontal and Vertical

Level PK (Peak) = Reading PK (Peak) + Factor (Antenna Factor + Cable Loss - Amp. Gain)

Level AV (Average) = Reading AV (Average) + Factor (Antenna Factor + Cable Loss - Amp. Gain)

Margin PK (Peak) = Limit – Level PK (Peak)

Margin AV (Average) = Limit – Level AV (Average)

Appendix – EUT photography



Front View



Rear View & Label location



Top View

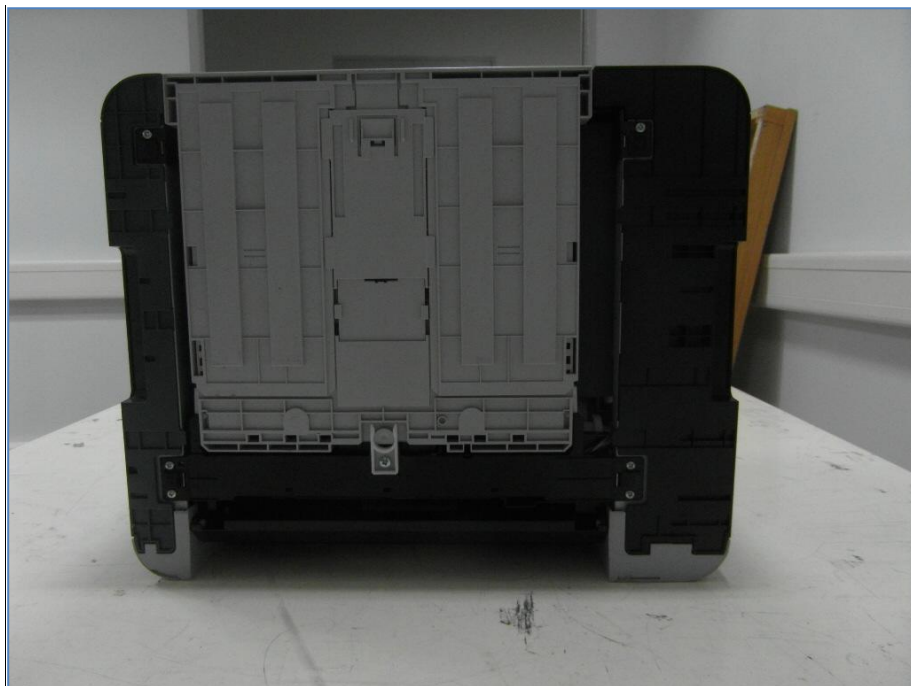

Bottom View



Right View



Left View



Inside View(Left side)



Inside View(Right side)



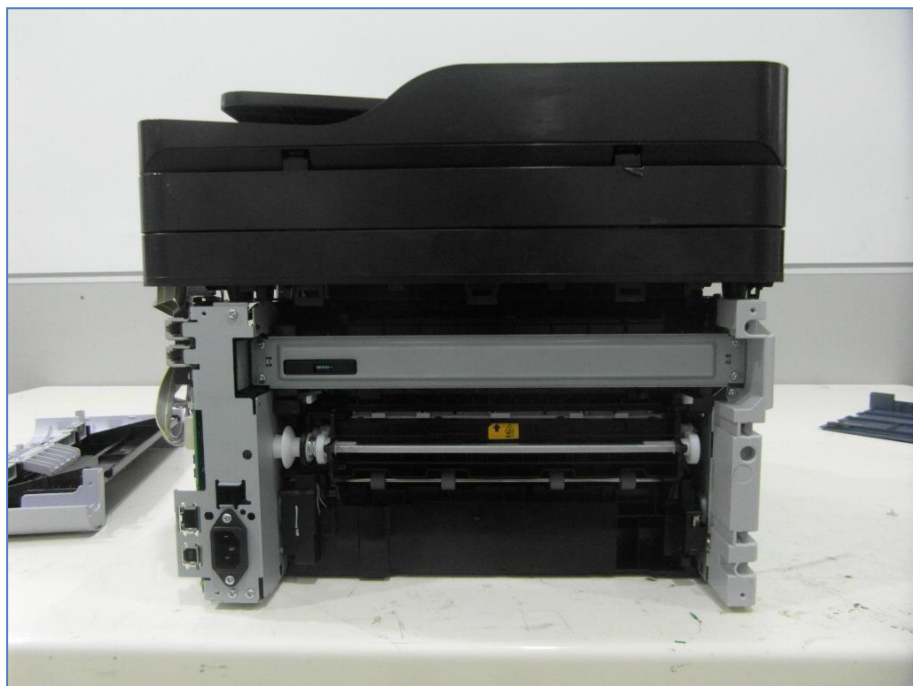

Inside View(Front side)



Inside View(Rear side)



| | | |
|---|---|--|
|  USOC Jack Type:RJ11C Samsung Electronics Co., Ltd. Suwon, Korea, 443-742 Place: M264 | Model: CLX-3305FW | FCC ID : A3LCLX3305FW |
| | Volts: AC 110-127V | Hertz: 50/60 Hz |
| | Amps: 6A | This device complies with part 15 of the FCC Rules. |
| | Ringer Equivalence:0.0B | Operation is subject to the following two conditions: |
| | Manufactured: | i) This device may not cause harmful interference, and |
| |  3UU7 | ii) This device must accept any interference received, |
| | E337632 | including interference that may cause undesired operation. |
| | I.T.E. | Complies with Part 68, FCC Rules. |
| | | FCC Certification No.:US:A3LFA00BCLX3305FW |
| | | This Class B digital apparatus complies with Canadian ICES-003 |
| | | Cet appareil numérique de la classe B est |
| | | Conforme à la norme NMB-003 du Canada. |
| | | This product complies with 21 CFR Chapter 1, subchapter J. |
| | | Contains IC : 649E-SPWB4319S |
| | | IC:649E-CLX3305FW |
| Serial No.: | | Made in China |
| | | Fabriqué en Chine REV.00 |

Label