

EMC TEST REPORT

Samsung Electronics Co., Ltd.

416 Maetan 3-Dong, Yeongtong-Gu,
Suwon-Si, Gyeonggi-Do, 443-742 Korea
(Tel: 82 31 277 7752, Fax: 82 31 277 7753)

Project No. : LBE070737
Page (1)/(29)

**1. Applicant**

- Name of organization : Samsung Electronics Co., Ltd.
- Address : 416 Maetan 3-Dong, Yeongtong-Gu, Suwon-Si, Gyeonggi-Do, 443-742 Korea
- Date of application : 2007. 03. 09

2. Purpose for the report : Approval for EMC

3. Kind of product : Printer (Model name :CLX-2160N)

4. Date of test : 2007. 03. 09 ~ 2007. 03. 12

5. Applied standard : FCC Part 15, Subpart B

6. Test result : Complied

The equipment under test has found to be compliant with the applied standards.

(Refer to the attached test result for more detail.)

Tested by

Name : Young Hun, Cheong

Reviewed by

Name : No Cheon Park

This report is the test result about the sphere accredited by KOLAS which signed the Mutual Recognition Arrangement of International Laboratory Accreditation Cooperation.

2007. 03. 19

Samsung Electronics Co., Ltd.
Chief of CS Management Center

TEST RESULT

Test Report No. : LBE070737

Applicant / Address : Samsung Electronics Co., Ltd.
416 Maetan 3-Dong, Yeongtong-Gu, Suwon-Si, Gyeonggi-Do
443-742 Korea

Manufacture / Address : 1) Samsung Electronics Co., Ltd.
259, Gongdan-Dong, Gumi-City, Gyeongsangbuk-Do, 730-030 Korea
2) Samsung Electronics(Shandong) Digital Printing Co., Ltd.
264209, Samsung Road, Weihai Hi-Tech IDZ, Shandong Province, China

EUT : 1. Product name : Printer
2. Model name : CLX-2160N
3. Brand name : SAMSUNG
4. Variant model : -
5. FCC ID : A3LCLX2160N

Test Method : **ANSI C 63.4:2003**

Test Result : **PASS**
The equipment under test has found to be compliant with the applied standards

Test Lab. : CS Management Center, Samsung Electronics Co., Ltd.



Tested by : Young Hun Cheong

Reviewed by : No Cheon Park

Date of Issue : 2007. 03. 19

Table of contents

1. General information

- 1.1 Basic information related product
- 1.2 Detail information related product
- 1.3 Operating mode and condition
- 1.4 Equipment modifications
- 1.5 Test procedure
- 1.6 Test configuration
- 1.7 Applied standard
- 1.8 Test facility

2. Summary of test results

3. Description of individual tests

- 3.1 Conducted emission
- 3.2 Radiated emission

4. Appendix

- 4.1 Test photography
- 4.2 EUT photography

1. General information

1.1 Basic information related product

Applicant	Samsung Electronics Co., Ltd.
Model name	CLX-2160N
Applicant address	416 Maetan 3-Dong, Yeongtong-Gu, Suwon-Si, Gyeonggi-Do 443-742 Korea
Contact person	Sangsu ROH
Kind of product	Printer
Valiant model	-
FCC ID	A3LCLX2160N
Manufacturer	1) Samsung Electronics Co., Ltd. 259, Gongdan-Dong, Gumi-City, Gyeongsangbuk-Do, 730-030 Korea 2) Samsung Electronics(Shandong) Digital Printing Co., Ltd. 264209, Samsung Road, Weihai Hi-Tech IDZ, Shandong Province, China
Rated power	AC 120 V, 60 Hz
New / Alternative / Permissive change information	New

1.2 Detail Information related product

1.2.1 Specification

Items		Maple	Remarks
General	Major Features	As Standalone: Copier, Printer, Scan, Scan to USB As Network connected: Network Print, Scan to E-mail	-
	Size (W*D*H)	413.6W×353.2D ×333.4H mm (16.26*13.9*12.12 inch)	-
	Net Weight(Inc. Toner Cartridge)	20.5 Kg (45.2 lbs)	-
Power Consumption	Ready	Less than 160W	-
	AVG.	Less than 350W (Currency:5A(110V)/3A(220V))	-
	Max/Peak	700W/1KW	-
	Sleep/Power off	Less than 30W	-
Power Supply	Input Voltage	Low Voltage : 110 ~ 127VAC	-
	Input Frequency	50 / 60Hz(+/- 3Hz)	-
Warm Up Time	from Cold Status	Less than 35 seconds	Rated Voltage
EMI Approval		Class B	-
Device Memory	Standard / Max.	128MB / 128MB(Std./Max)	-
	Type	SDRAM	-
PRINT	Print Speed	B&W :17ppm/Letter 16ppm/A4 Color : 4ppm/A4.Letter	-
	Print Emulation	SPL-C	-

Operating Frequency

Main Clock = 12MHz
 Main CPU core Clock = 300MHz
 USB Clock = 6MHz
 SD Memory Clock = 100MHz
 MAC Clock = 25MHz

1.3 Operating mode and condition

The system was configured for testing in typical fashion use. Cable were attached to each of the available I/O port. Where applicable, peripherals were attached to the I/O cables.

This EUT is supporting the USB, Parallel and Network(LAN) printing.

In each test mode, finally we found worst case emission that is above configuration with the Worst case components(in the above table). So, the data of the maximum EUT operation, Network printing(duplex mode) was reported.

- **Operating Mode**
- **Standby Mode(worst emission)**
- Network Printing Mode
- USB Printing Mode

- Test Voltage : 120 V, 60 Hz

1.4 Equipment modifications

No equipment modifications were required.

1.5 Test procedure

1.5.1 Conducted emission

EUT was placed on a platform nominal size, 1 m by 1.5 m, raised 80 cm above the conducting ground plane. The rear of tabletop was located 40 cm to the vertical conducting ground plane.

The rear of EUT, including peripherals was aligned and flush with rear of tabletop.

All other surfaces of tabletop was at least 80 cm from any other grounded conducting surface.

I/O cables and AC cables that were connected to the peripherals were bundled in center.

They were folded back and forth forming a bindle 30 cm to 40 cm long and were handed at a 40 cm height to the ground plane.

Each EUT current-carrying power lead, except the ground(safety) lead, were individually connected through a LISN to the input power source.

All unused 50 ohm connectors of the LISN were resistively terminated in 50 ohm when not connected to the measuring equipment.

Frequency Band [MHz]	Instrument	Detector	Resolution Bandwidth	Video Bandwidth
0.15 to 30	EMI Receiver	Quasi-Peak	9 kHz	-
		Average	9 kHz	-

1.5.2 Radiated emission

EUT was placed on a platform of nominal size, 1 m by 1.5 m, raised 80 cm above the conducting ground plane. The rear of EUT, including peripherals was aligned and flush with rear of tabletop.

The I/O cables that were connected to the peripherals were bundle in center.

They were folded back and forth forming a bundle 30 cm to 40 cm long and were hanged 40 cm height to the ground plane.

Test was made with the antenna positioned in both the horizontal and vertical planes of polarization.

The measurement antenna was varied in height above the conducting ground plane and the turn table azimuth was varied to obtain the maximum signal strength

The system configuration, clock speed, mode of operation or video resolution, turntable azimuth with respect to the antenna were noted for each frequency found.

The spectrum was scanned from 30 to 1 000 MHz using biconiLog antenna.

Also, the EMI Receiver was scanned from 1 000 to 2 000 MHz using linearly polarization

Double ridge horn antennas were used. The explanation of measuring instrument setup when

Respective function is used in any frequency band is as following;

Frequency Band [MHz]	Instrument	Detector	Resolution Bandwidth	Video Bandwidth
30 to 1 000	EMI Receiver	Quasi-Peak	120 kHz	-
Above 1 000	EMI Receiver	Peak	1 MHz	1 MHz

1.6 Test configuration

1.6.1 Used EUT and peripherals

Seq	Device	Model Name	Serial #	Maker	FCC ID
A	Printer	CLX-2160N	-	Samsung	A3LCLX2160N
B	N PC	PP02X	17564458672	DELL	Doc
C	AC Adaptor	PA-1900-02DK	CN-0D1104-71615-428-00E1	DELL	-
D	USB Mouse	M-UAE96	LZK61923409	LOGITECH INE.	Doc
E	Headset	-	-	PLANTRONICS	-

1.6.2 Used cable description

No	Connect Cable	Length [m]	Shielded [Y/N]	Remark
1	Power	1.8	No	For EUT
2	Power	1.8	No	For PC
3	USB	1.8	Yes	For PC
4	Headset	1.0	Yes	For PC
5	LAN(RJ45)	3.5	No	For EUT
6	USB	2.0	No	For PC ant EUT

1.6.3 Block diagram

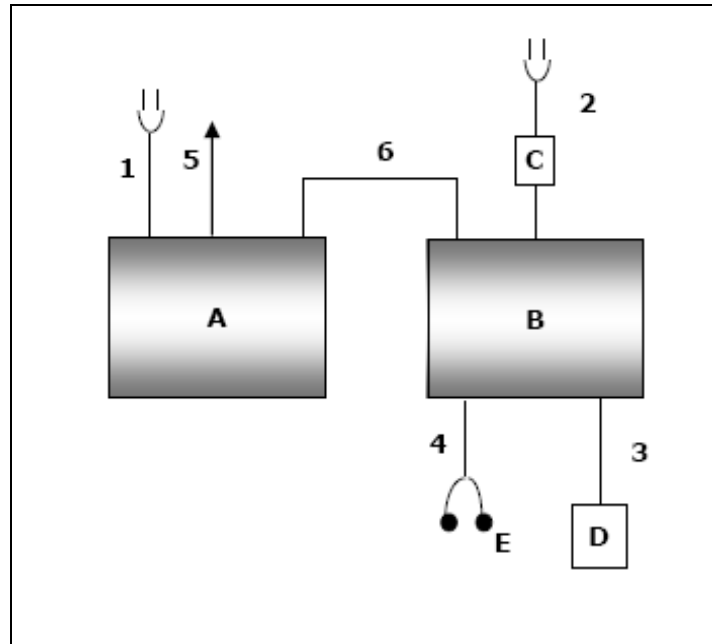

1.7 Applied Standards

Test standard	Test method
FCC Part 15 Subpart B	ANSI C63.4:2003

1.8 Test Facility

1.8.1 General information

The sites are constructed in conformance with the requirements of ANSI C63.4 and CISPR 22, 16-1, 16-2.

This EMC Testing Lab. is accredited by Korea Laboratory Accreditation Scheme(KOLAS) which signed the International Laboratory Accreditation Cooperation (ILAC) Mutual Recognition Arrangement

(MRA) for the above test item(s) and test method(s).

This Lab. is operated as testing laboratory in accordance with the requirements of ISO/IEC 17025:1998.

1.8.2 Accreditation and listing



1.8.3 Measurement uncertainty

(According to CISPR 16-4 and Lab. 34)

Test item	Measurement uncertainty
Conducted emission	± 2.8 dB
Radiated emission Horizontal	± 5.1 dB
Vertical	± 5.09 dB

2. Summary of test results

Result : PASS

The equipment under test(EUT) has been found to comply with the applied standards.

Section of the product standard		Applied standard	Test result
3.1	Conducted Emission	ANSI C63.4 : 2003	Complied
3.2	Radiated Emission	ANSI C63.4 : 2003	Complied

3. Description of individual tests

3.1 Conducted emission

3.1.1 Test information

Test engineer	Young Hun, Cheong
Test date	March 12, 2007
Climate condition	Ambient temperature : 23.9 °C, Relative humidity : 35 % Atmospheric pressure : 101.6 kPa
Test place	Shielded room # 1

3.1.2 Test equipment

Equipment	Model name	Manufacturer	Serial no.	Calibration	
				Date	Interval (Month)
EMI TEST RECEIVER	ESCI	R&S	100369	2006-05-01	12
LISN	ENV216	R&S	100116	2006-09-01	12
LISN	ESH3-Z5	R&S	100261	2006-07-21	12
Test Software	EMC 32	R&S	Ver 4.40.0	N/A	N/A

EUT Test Setup

The EUT was set up as per normal use on a wooden table, 0.4 m from a vertical ground reference plane, At least 0.8 m from other conduction surfaces and 0.8 m from the LISN.

See photo.

Test Result

Measurement Results

Pass
The measured emissions of the EUT have found to be below the specified limits.

3.1.3 Test data and graph

The initial step in collecting conducted data was to perform a peak and average scan over the measurement range using a receiver.

3.1.4.1 Test graph

Test Information

Test Description: CLX-2160N
 Operating Conditions:
 Operator Name:
 Comment: USB Printing

Hardware Setup: Voltage with ENV 2-Line-LISN - [EMI conducted]

Subrange 1
 Frequency Range: 150kHz - 30MHz
 Receiver: ESCI 3 [ESCI 3]
 @ GPIB0 (ADR 20), SN 100369/003, FW 3.82
 Signal Path: Receiver-2-Line-LISN ENV216
 FW 1.0
 Correction Table: Receiver-2-LISN ENV216
 LISN: ENV216
 Correction Table (Line 0): ENV216_100116_N
 Correction Table (Line 1): ENV216_100116_L

Scan Setup: EN55022_B_ENV 2-Line-LISN fin [EMI conducted]

Hardware Setup: Voltage with ENV 2-Line-LISN
 Level Unit: dB μ V

Subrange	Detectors	IF Bandwidth	Meas. Time	Receiver
150kHz - 30MHz	QuasiPeak; Average	9kHz	15s	ESCI 3

EN55022_B with ENV 2-Line-LISN

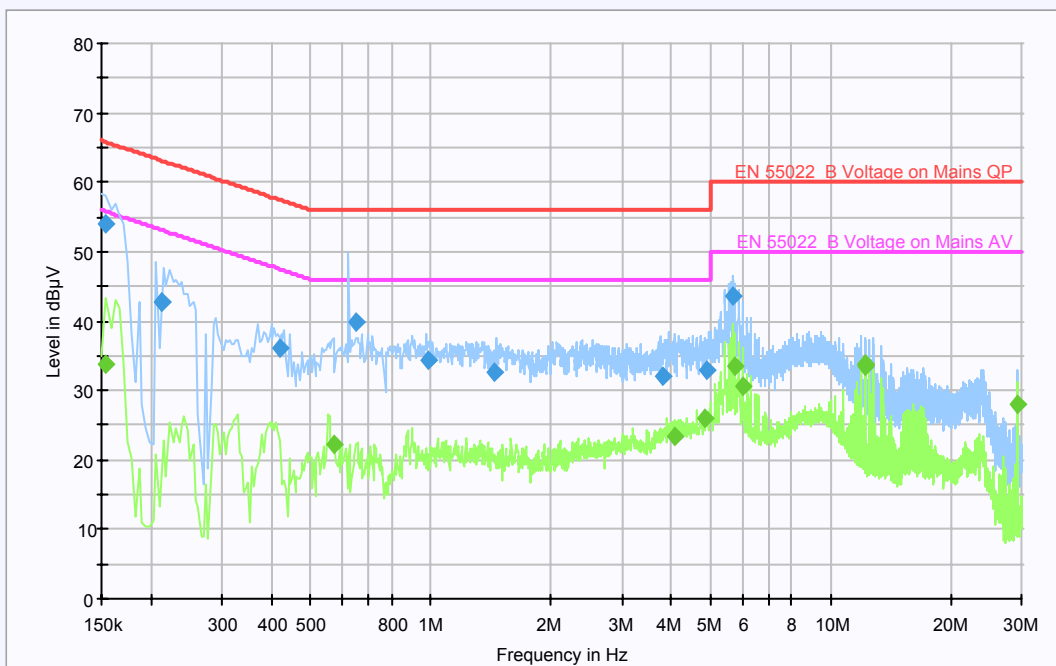

Final Measurement Detector 1

Frequency (MHz)	QuasiPeak (dB μ V)	Line	Corr. (dB)	Margin (dB)	Limit (dB μ V)
0.154 000	54.0	N	9.6	11.8	65.8
0.211 300	42.7	N	9.6	20.5	63.2
0.211 700	42.7	N	9.6	20.4	63.1
0.417 900	36.0	L1	9.7	21.5	57.5
0.653 100	39.9	N	9.6	16.1	56.0
0.981 300	34.4	L1	9.6	21.6	56.0
1.447 000	32.7	L1	9.7	23.3	56.0
3.806 600	32.2	N	9.7	23.8	56.0
4.875 000	33.0	L1	9.8	23.0	56.0
5.702 000	43.6	N	9.8	16.4	60.0

Final Measurement Detector 2

Frequency (MHz)	Average (dB μ V)	Line	Corr. (dB)	Margin (dB)	Limit (dB μ V)
0.153 900	33.8	L1	9.6	22.0	55.8
0.570 300	22.3	L1	9.6	23.7	46.0
4.081 400	23.5	L1	9.7	22.5	46.0
4.850 200	26.1	L1	9.8	19.9	46.0
5.730 000	33.6	N	9.8	16.4	50.0
6.015 200	30.6	L1	9.8	19.4	50.0
12.197 500	33.6	L1	9.9	16.4	50.0
12.198 000	33.8	L1	9.9	16.2	50.0
12.198 500	33.8	L1	9.9	16.2	50.0
29.269 000	28.0	L1	10.2	22.0	50.0

* QP : Quasi-peak, AV: Average

* Level (QuasiPeak or Average) = Meter Reading(QP or AV) + Corr. (LISN Insertion loss + Cable loss)

* Margin = Limit – Result

Test Information

Test Description: CLX-2160N
 Operating Conditions:
 Operator Name:
 Comment: Network Printing

Hardware Setup: Voltage with ENV 2-Line-LISN - [EMI conducted]

Subrange 1
 Frequency Range: 150kHz - 30MHz
 Receiver: ESCI 3 [ESCI 3]
 @ GPIB0 (ADR 20), SN 100369/003, FW 3.82
 Signal Path: Receiver-2-Line-LISN ENV216
 FW 1.0
 Correction Table: Receiver-2-LISN ENV216
 LISN: ENV216
 Correction Table (Line 0): ENV216_100116_N
 Correction Table (Line 1): ENV216_100116_L

Scan Setup: EN55022_B_ENV 2-Line-LISN fin [EMI conducted]

Hardware Setup: Voltage with ENV 2-Line-LISN
 Level Unit: dB μ V

Subrange	Detectors	IF Bandwidth	Meas. Time	Receiver
150kHz - 30MHz	QuasiPeak; Average	9kHz	15s	ESCI 3

EN55022_B with ENV 2-Line-LISN

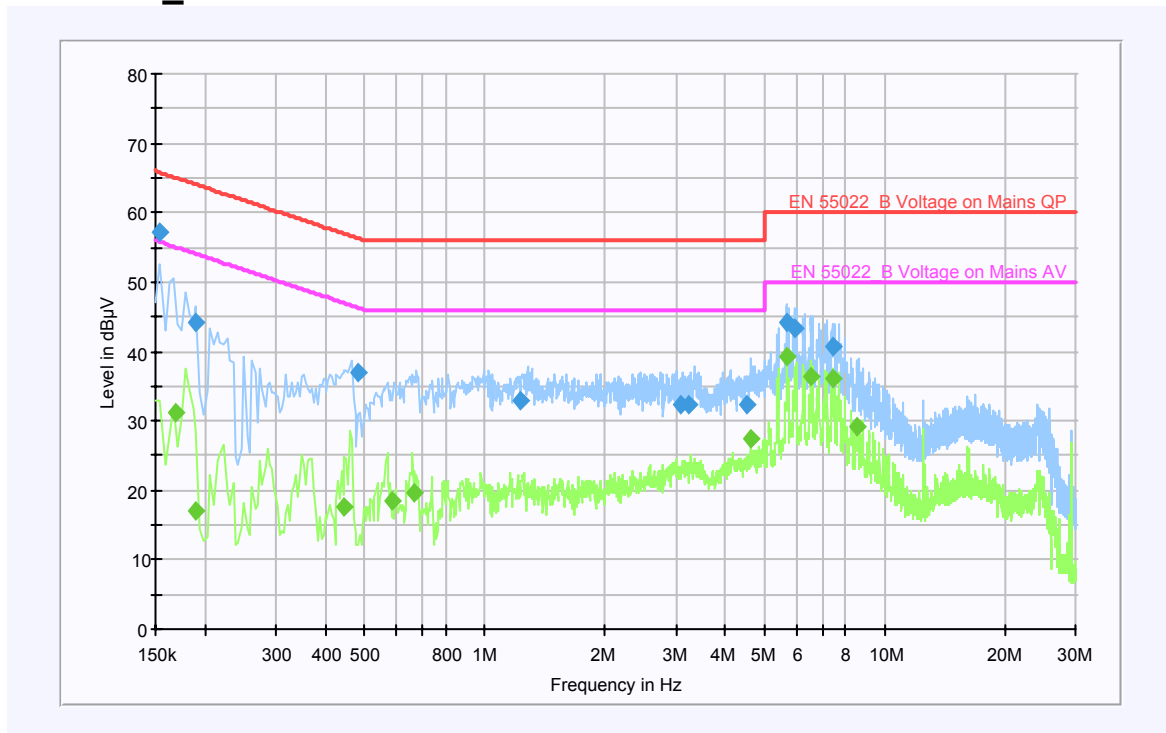

Final Measurement Detector 1

Frequency (MHz)	QuasiPeak (dB μ V)	Line	Corr. (dB)	Margin (dB)	Limit (dB μ V)
0.154 000	57.3	N	9.6	8.5	65.8
0.188 500	44.2	L1	9.6	19.9	64.1
0.482 700	37.0	L1	9.6	19.3	56.3
1.220 000	32.9	L1	9.7	23.1	56.0
3.082 000	32.3	L1	9.7	23.7	56.0
3.228 200	32.2	L1	9.7	23.8	56.0
4.501 800	32.3	L1	9.7	23.7	56.0
5.679 800	44.1	L1	9.8	15.9	60.0
5.989 400	43.2	L1	9.8	16.8	60.0
7.402 800	40.7	N	9.8	19.3	60.0

Final Measurement Detector 2

Frequency (MHz)	Average (dB μ V)	Line	Corr. (dB)	Margin (dB)	Limit (dB μ V)
0.169 100	31.2	L1	9.6	23.8	55.0
0.188 900	17.1	L1	9.6	37.0	54.1
0.442 900	17.6	L1	9.7	29.4	47.0
0.585 500	18.4	N	9.6	27.6	46.0
0.665 100	19.6	L1	9.6	26.4	46.0
4.609 600	27.5	L1	9.7	18.5	46.0
5.675 800	39.3	L1	9.8	10.7	50.0
6.531 600	36.4	L1	9.8	13.6	50.0
7.382 800	36.2	N	9.8	13.8	50.0
8.515 600	29.2	N	9.8	20.8	50.0

* QP : Quasi-peak, AV: Average

* Level (QuasiPeak or Average) = Meter Reading(QP or AV) + Corr. (LISN Insertion loss + Cable loss)

* Margin = Limit – Result

Test Information

Test Description: CLX-2160N
 Operating Conditions:
 Operator Name:
 Comment: Standby

Hardware Setup: Voltage with ENV 2-Line-LISN - [EMI conducted]

Subrange 1
 Frequency Range: 150kHz - 30MHz
 Receiver: ESCI 3 [ESCI 3]
 @ GPIB0 (ADR 20), SN 100369/003, FW 3.82
 Signal Path: Receiver-2-Line-LISN ENV216
 FW 1.0
 Correction Table: Receiver-2-LISN ENV216
 LISN: ENV216
 Correction Table (Line 0): ENV216_100116_N
 Correction Table (Line 1): ENV216_100116_L

Scan Setup: EN55022_B_ENV 2-Line-LISN fin [EMI conducted]

Hardware Setup: Voltage with ENV 2-Line-LISN
 Level Unit: dB μ V

Subrange	Detectors	IF Bandwidth	Meas. Time	Receiver
150kHz - 30MHz	QuasiPeak; Average	9kHz	15s	ESCI 3

EN55022_B with ENV 2-Line-LISN

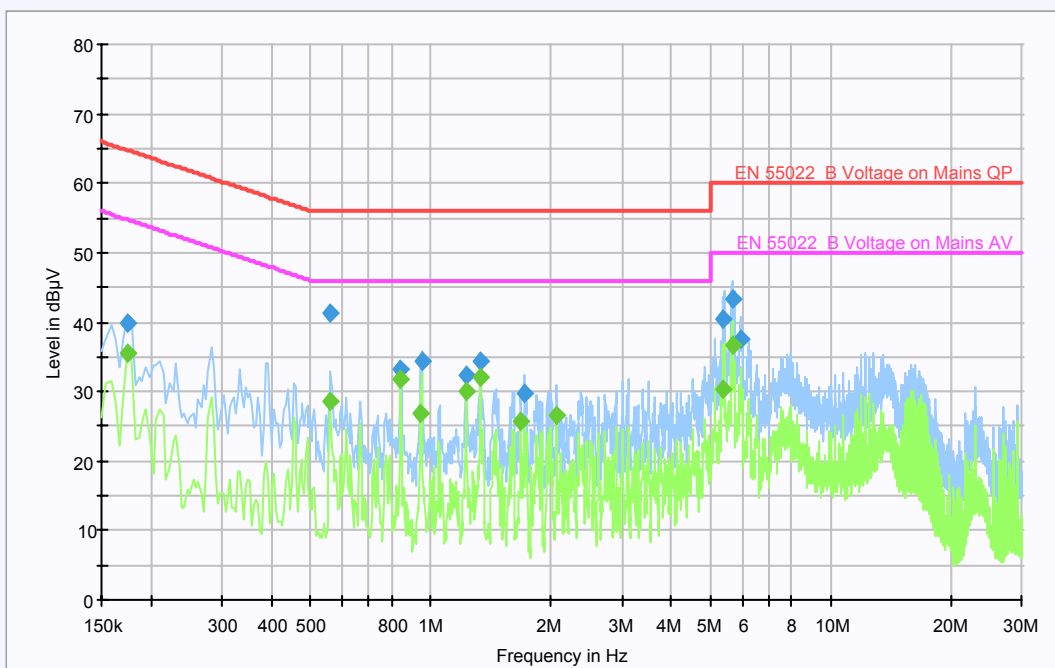

Final Measurement Detector 1

Frequency (MHz)	QuasiPeak (dB μ V)	Line	Corr. (dB)	Margin (dB)	Limit (dB μ V)
0.173 300	39.8	N	9.6	25.0	64.8
0.561 900	41.2	L1	9.6	14.8	56.0
0.839 900	33.2	N	9.6	22.8	56.0
0.946 700	34.5	N	9.6	21.5	56.0
1.222 800	32.3	N	9.6	23.7	56.0
1.329 400	34.2	N	9.6	21.8	56.0
1.714 200	29.9	N	9.7	26.1	56.0
5.383 600	40.5	L1	9.8	19.5	60.0
5.677 000	43.2	N	9.8	16.8	60.0
5.964 000	37.5	N	9.8	22.5	60.0

Final Measurement Detector 2

Frequency (MHz)	Average (dB μ V)	Line	Corr. (dB)	Margin (dB)	Limit (dB μ V)
0.173 300	35.4	N	9.6	19.4	54.8
0.561 900	28.5	N	9.6	17.5	46.0
0.839 900	31.7	N	9.6	14.3	46.0
0.938 700	26.8	N	9.6	19.2	46.0
1.222 800	29.9	N	9.6	16.1	46.0
1.329 400	31.9	N	9.6	14.1	46.0
1.678 200	25.8	N	9.7	20.2	46.0
2.064 800	26.5	N	9.7	19.5	46.0
5.371 600	30.4	L1	9.8	19.6	50.0
5.685 000	36.5	N	9.8	13.5	50.0

* QP : Quasi-peak, AV: Average

* Level (QuasiPeak or Average) = Meter Reading(QP or AV) + Corr. (LISN Insertion loss + Cable loss)

* Margin = Limit – Result

3.2 Radiated emission

3.2.1 Test information

Test engineer	Young Hun, Cheong
Test date	March 09, 2007
Climate condition	Ambient temperature : 23.0 °C, Relative humidity : 32 % Atmospheric pressure 100.6 kPa
Test place	10 m Semi-anechoic Chamber

3.2.2 Test equipment

Equipment	Model name	Manufacturer	Serial no.	Calibration	
				Date	Interval (Month)
Bi-con Antenna	CBL6112D	SCHAFFNER	22602	2006-06-26	12
EMI Receiver	ESI-26	R&S	100288	2006-04-04	12
AMPLIFIER	310N	SONOMA	251674	2006-03-14	12
Ant Mast	MA4000	Inn-co	-	N/A	N/A
Mast Controller	CO2000	Inn-co	-	N/A	N/A
RF Selector	NS4900	TOYO	-	N/A	N/A

EUT Test Setup

EUT set up in semi-anechoic chamber. EUT positioned at 10 m from antenna in center of table.

All ports terminated into characteristic loads.

Test Result

Measurement Results	Pass The measured emissions of the EUT have found to be below the specified limits.
----------------------------	--

3.2.3 Test data and graph

The initial step in collecting radiated data was to perform a peak scan over the measurement range using a receiver. All modes of operation were investigated and the worst-case emissions were reported. All other emissions are non-significant

3.2.4 30 MHz ~ 1 000 MHz

■ Operating Mode: **Standby**

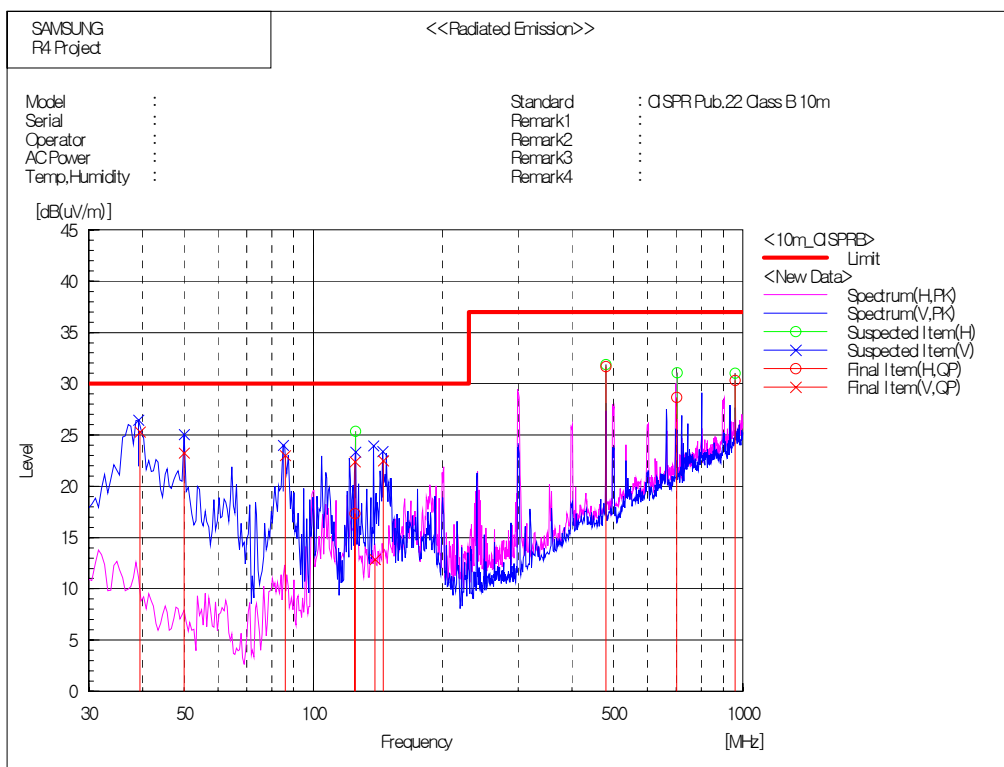

- * Receiving antenna mode : Horizontal, Vertical
- * Test distance : 10m (RF Semi Anechoic Chamber)
- * Result = Reading + c.f (Antenna factor + Cable loss- Amp Gain)
- * Margin = Limit – Result

■ Operating Mode: Network Printing

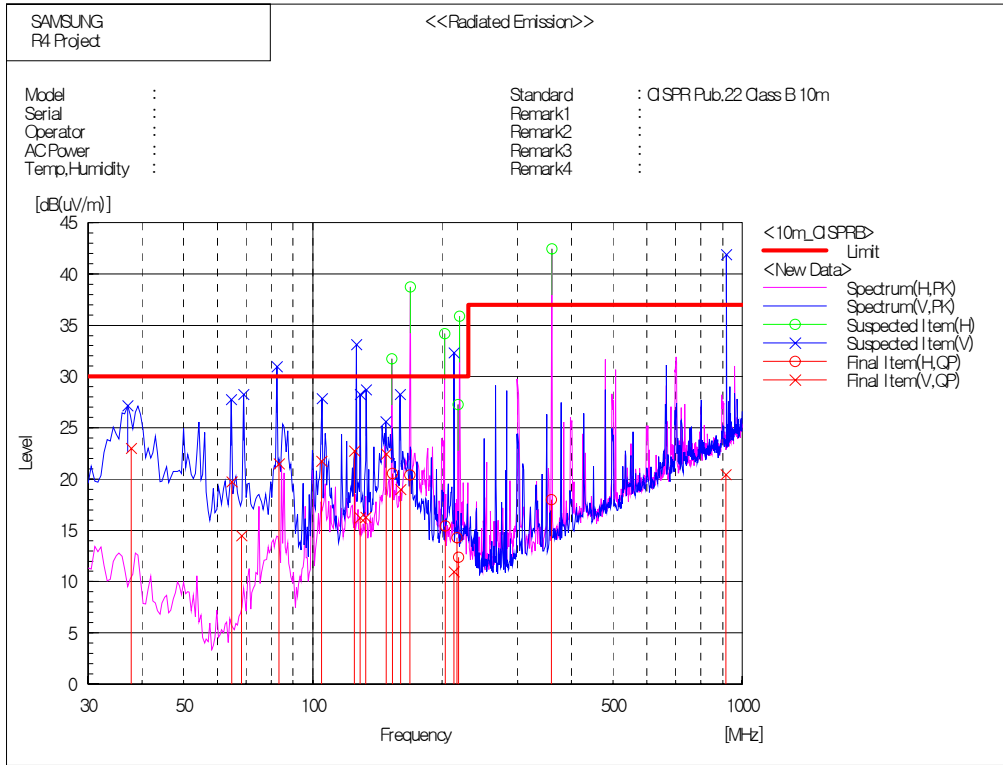

Final Result

No.	Frequency [MHz]	(P)	Reading QP [dB(uV)]	c.f [dB(1/m)]	Result QP [dB(uV/m)]	Limit [dB(uV/m)]	Margin QP [dB]	Height [cm]	Angle [deg]	System
1	37.794	V	40.1	-17.1	23.0	30.0	7.0	100.0	255.2	2
2	64.783	V	44.6	-24.9	19.7	30.0	10.3	224.0	13.3	2
3	68.225	V	39.1	-24.6	14.5	30.0	15.5	131.0	45.1	2
4	83.375	V	43.8	-22.3	21.5	30.0	8.5	154.0	27.0	2
5	104.710	V	40.1	-18.4	21.7	30.0	8.3	115.0	285.7	2
6	124.979	V	40.2	-17.5	22.7	30.0	7.3	100.0	245.7	2
7	128.885	V	33.8	-17.5	16.3	30.0	13.7	114.0	8.6	2
8	132.922	V	33.8	-17.5	16.3	30.0	13.7	101.0	359.3	2
9	148.110	V	41.0	-18.6	22.4	30.0	7.6	152.0	260.9	2
10	153.191	H	40.0	-19.4	20.6	30.0	9.4	400.0	164.0	1
11	159.965	V	38.1	-19.1	19.0	30.0	11.0	101.0	319.9	2
12	168.422	H	40.1	-19.7	20.4	30.0	9.6	324.0	142.9	1
13	203.376	H	35.3	-19.9	15.4	30.0	14.6	362.0	27.0	1
14	212.970	V	30.8	-19.8	11.0	30.0	19.0	157.0	41.2	2
15	216.454	H	34.3	-20.0	14.3	30.0	15.7	400.0	307.6	1
16	218.813	H	32.4	-20.0	12.4	30.0	17.6	335.0	108.0	1
17	359.963	H	30.7	-12.7	18.0	37.0	19.0	215.0	359.6	1
18	915.502	V	23.5	-3.1	20.4	37.0	16.6	201.0	97.1	2

- * Receiving antenna mode : Horizontal, Vertical
- * Test distance : 10m (RF Semi Anechoic Chamber)
- * Result = Reading + c.f (Antenna factor + Cable loss- Amp Gain)
- * Margin = Limit – Result

■ Operating Mode: **USB Printing**

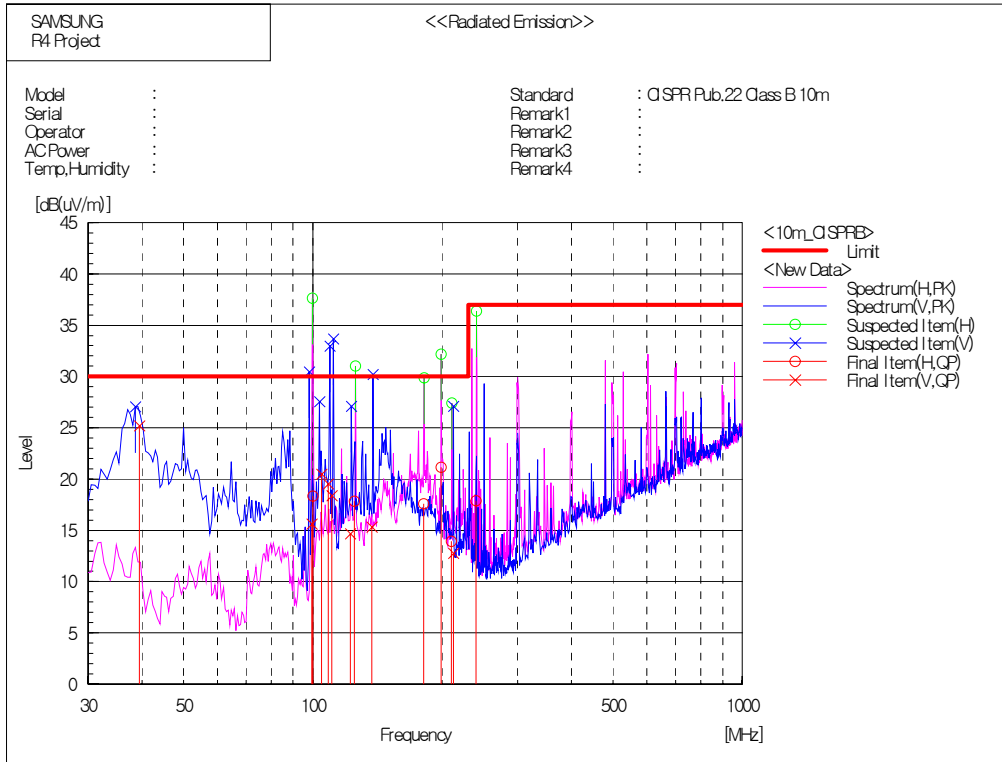

Final Result

No.	Frequency [MHz]	(P)	Reading QP [dB(uV)]	c.f [dB(1/m)]	Result QP [dB(uV/m)]	Limit [dB(uV/m)]	Margin QP [dB]	Height [cm]	Angle [deg]	System
1	39.466	V	43.1	-17.9	25.2	30.0	4.8	101.0	13.8	2
2	199.259	H	41.0	-19.9	21.1	30.0	8.9	368.0	204.8	1
3	104.759	V	38.9	-18.4	20.5	30.0	9.5	109.0	280.1	2
4	108.774	V	37.6	-18.1	19.5	30.0	10.5	100.0	290.3	2
5	110.781	V	36.3	-17.9	18.4	30.0	11.6	111.0	288.6	2
6	100.154	H	37.4	-19.1	18.3	30.0	11.7	398.0	105.1	1
7	124.984	H	35.4	-17.6	17.8	30.0	12.2	372.0	48.7	1
8	181.408	H	38.0	-20.4	17.6	30.0	12.4	308.0	198.4	1
9	99.526	V	34.6	-19.0	15.6	30.0	14.4	106.0	287.3	2
10	137.456	V	33.1	-17.8	15.3	30.0	14.7	112.0	353.2	2
11	122.425	V	32.2	-17.5	14.7	30.0	15.3	100.0	359.2	2
12	210.432	H	34.1	-20.1	14.0	30.0	16.0	376.0	154.2	1
13	212.423	V	32.6	-19.8	12.8	30.0	17.2	100.0	353.8	2
14	240.013	H	35.3	-17.4	17.9	37.0	19.1	362.0	291.5	1

- * Receiving antenna mode : Horizontal, Vertical
- * Test distance : 10m (RF Semi Anechoic Chamber)
- * Result = Reading + c.f (Antenna factor + Cable loss- Amp Gain)
- * Margin = Limit – Result

3.2.5 1 GHz ~ 2 GHz

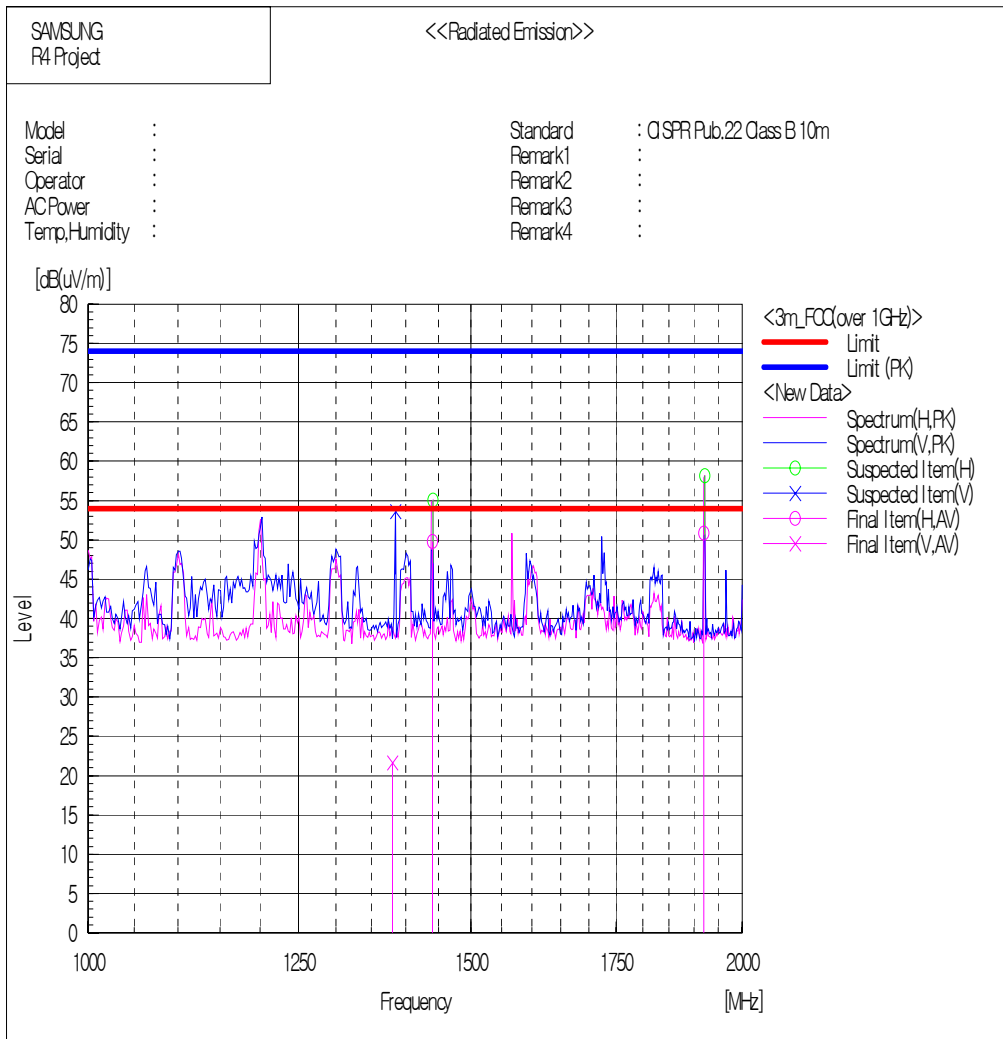

Final Result

No.	Frequency (P)	Reading	c.f	Result	Limit	Margin	Height	Angle
	[MHz]	AV		AV		AV		
		[dB(uV)]	[dB(1/m)]	[dB(uV/m)]	[dB(uV/m)]	[dB]	[cm]	[deg]
1	1440.301	H 54.7	-4.9	49.8	54.0	4.2	139.0	118.4
2	1920.422	H 53.3	-2.4	50.9	54.0	3.1	107.0	44.4
3	1380.222	V 26.6	-5.0	21.6	54.0	32.4	117.0	89.4

- * Receiving antenna mode : Horizontal, Vertical
- * Test distance : 3 m (Semi Anechoic Chamber)
- * Result = Reading + c.f (Antenna factor + Cable loss- Amp Gain)
- * Margin = Limit – Reading

4. Appendix

4.1 Test photography



Picture 1. Conducted Emission (Front)



Picture 2. Conducted Emission (Rear)

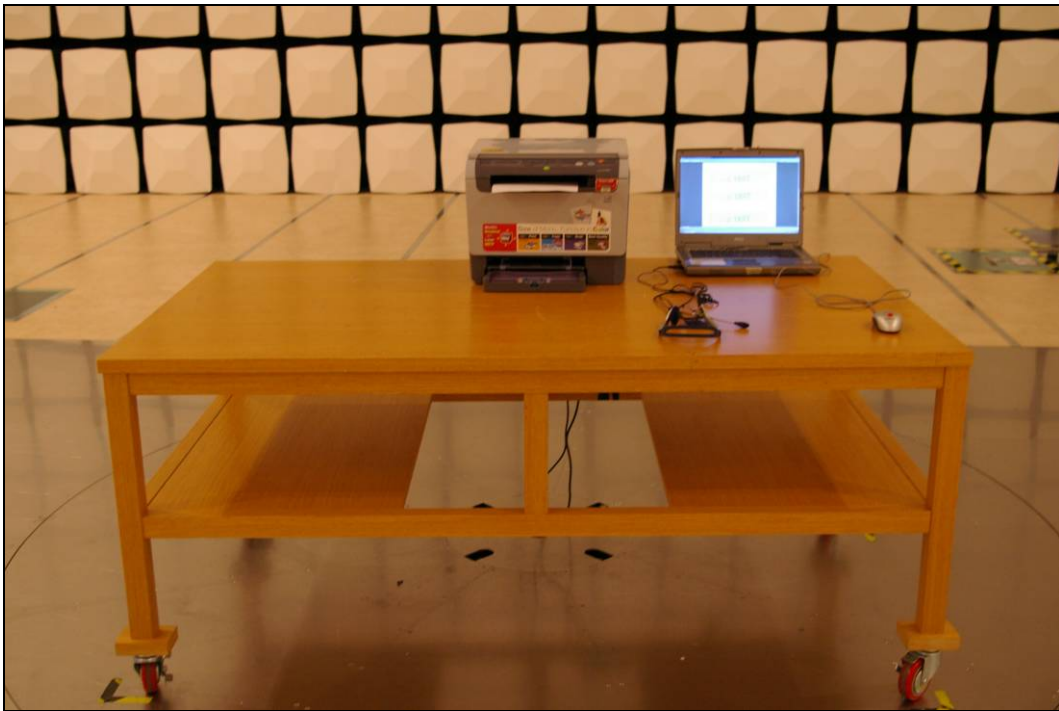

Picture 3. Radiated emission (Front)

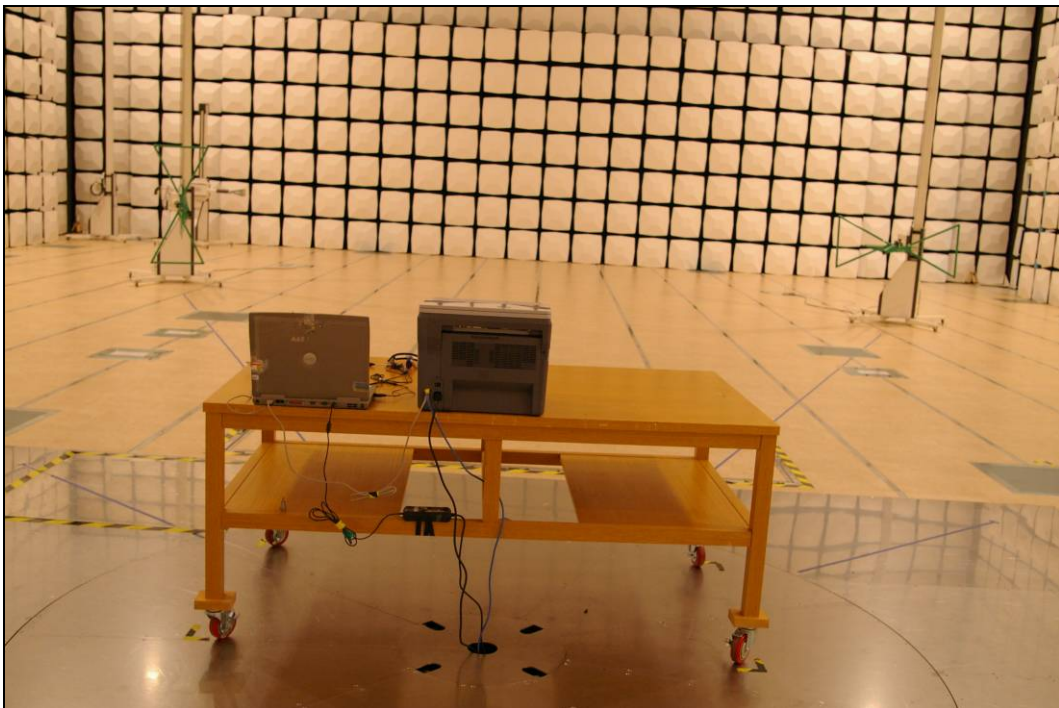

Picture 4. Radiated emission (Rear)

4.2 EUT photography







Picture 5. EUT (Front)



Picture 6. EUT (Rear)

4.3 Label and Label Location

 Samsung Electronics Co., Ltd. Suwon, Korea, 443-742 Place:M264	Model: CLX-2160N Volts: AC 110-127V Hertz: 50/60Hz Amps: 5A Manufactured:	This device complies with part 15 of the FCC Rules. Operation is subject to the following two conditions: i) This device may not cause harmful interference, and ii) This device must accept any interference received, including interference that may cause undesired operation. FCC ID:A3LCLX2160N This product complies with 21 CFR Chapter 1, subchapter J. This Class B digital apparatus complies with Canadian ICES-003 Cet appareil numérique de la class B respecte toutes les exigences du règlement sur le matériel brouilleur du Canada. Cet appareil numérique de la classe B est Conforme à la norme NMB-003 du Canada.
Serial No.	 LISTED 51Y7 E149091 I.T.E.	MADE IN CHINA REV.00

 Samsung Electronics Co., Ltd. Suwon, Korea, 443-742 Place:M259	Model: CLX-2160N Volts: AC 110-127V Hertz: 50/60Hz Amps: 5A Manufactured:	This device complies with part 15 of the FCC Rules. Operation is subject to the following two conditions: i) This device may not cause harmful interference, and ii) This device must accept any interference received, including interference that may cause undesired operation. FCC ID:A3LCLX2160N This product complies with 21 CFR Chapter 1, subchapter J. This Class B digital apparatus complies with Canadian ICES-003 Cet appareil numérique de la class B respecte toutes les exigences du règlement sur le matériel brouilleur du Canada. Cet appareil numérique de la classe B est Conforme à la norme NMB-003 du Canada.
Serial No.	 LISTED 51Y7 E149091 I.T.E.	MADE IN KOREA REV.00

Picture 7. Label



Picture 8. Label location