

EMC TEST REPORT

Samsung Electronics Co., Ltd.

416 Maetan 3-Dong, Yeongtong-Gu,
Suwon-Si, Gyeonggi-Do, 443-742 Korea
(Tel: 82 31 277 7752, Fax: 82 31 277 7753)

Project No. : LBE072032
Page (1)/(29)

**1. Applicant**

- Name of organization : Samsung Electronics Co., Ltd.
- Address : 416 Maetan 3-Dong, Yeongtong-Gu, Suwon-Si, Gyeonggi-Do, 443-742 Korea
- Date of application : 2007. 06. 22

2. Purpose for the report : Approval for EMC

3. Kind of product : Printer (Model name :CLP-610ND)

4. Date of test : 2007. 06. 22 ~ 2007. 06. 23

5. Applied standard : FCC Part 15, Subpart B

6. Test result : **Complied**

The equipment under test has found to be compliant with the applied standards.

(Refer to the attached test result for more detail.)

Tested by

Name : Young Hun, Cheong

Handwritten signature of Young Hun, Cheong in black ink.

Reviewed by

Name : No Cheon Park

Handwritten signature of No Cheon Park in black ink.

This report is the test result about the sphere accredited by KOLAS which signed the Mutual Recognition Arrangement of International Laboratory Accreditation Cooperation.

2007. 06. 23

Samsung Electronics Co., Ltd.
Chief of CS Management Center

TEST RESULT

Test Report No. : LBE072032

Applicant / Address : Samsung Electronics Co., Ltd.
416 Maetan 3-Dong, Yeongtong-Gu, Suwon-Si, Gyeonggi-Do
443-742 Korea

Manufacture / Address : Samsung Electronics Co., Ltd.
259, Gongdan-Dong, Gumi-City, Gyeongsangbuk-Do, 730-030 Korea

EUT : 1. Product name : Printer
2. Model name : CLP-610ND
3. Brand name : SAMSUNG
4. Variant model : -
5. FCC ID : A3LCLP610ND

Test Method : **ANSI C63.4-2003**

Test Result : **Complied**
The equipment under test has found to be compliant with the applied standards

Test Lab. : CS Management Center, Samsung Electronics Co., Ltd.



Tested by : Young Hun Cheong

Reviewed by : No Cheon Park

Date of Issue : 2007. 06. 23

Table of contents

1. General information

- 1.1 Basic information related product
- 1.2 Detail information related product
- 1.3 Operating mode and condition
- 1.4 Equipment modifications
- 1.5 Test procedure
- 1.6 Test configuration
- 1.7 Applied standard
- 1.8 Test facility

2. Summary of test results

3. Description of individual tests

- 3.1 Conducted emission
- 3.2 Radiated emission

4. Appendix

- 4.1 Test photography
- 4.2 EUT photography

1. General information

1.1 Basic information related product

Applicant	Samsung Electronics Co., Ltd.
Model name	CLP-610ND
Applicant address	416 Maetan 3-Dong, Yeongtong-Gu, Suwon-Si, Gyeonggi-Do 443-742 Korea
Contact person	Sangsu ROH
Kind of product	Printer
Variant model	-
FCC ID	A3LCLP610ND
Manufacturer	Samsung Electronics Co., Ltd. 259, Gongdan-Dong, Gumi-City, Gyeongsangbuk-Do, 730-030 Korea
Rated power	AC 120 V, 60 Hz
New / Alternative / Permissive change information	New

1.2 Detail Information related product

1.2.1 Specification

Item	Specification and Description
Processor	S3C26L0(360MHz) Samsung
Standard System memory	128MB (option 128MB, 256MB)
Resolution	1200x600dpi (Standard) , 600x600dpi (High Speed) , 2400x600dpi Class (High Quality)
Paper Handling	Paper Tray(standard) 250 Sheets 2nd Tray(optional) 500 Sheets Bypass Tray 100 Sheets
Power Rating	110~127 VAC, 8A, 50/60 Hz
Power Consumption	Power save mode : 35Watts Stand by mode : 150Watts Printing simplex : 600Watts max : 1400Watts
Printer Language	SPL-C, PCL6
Interfaces	USB2.0, Ethernet 10/100 Tx Base
OS compatibility	Windows 2000/XP/2003/Vista Various Linux including Red Hat 8.0~9.0, Mandrake 9.2~10.1, SuSE 8.2~9.2 and Fedora Core 1~4 Mac OS 10.1 ~10.4 and Universal Mac
Modes of Operation	USB Printing, Network Printing, Duplex Printing
Intended Class for Emissions	Class B



Test Report No. : LBE072032

Operating Frequency

Main Source Clock	: 12.0 MHz
Video Clock	: 24.5625 MHz
CPU Internal Clock	: 360 MHz
DDR Clock	: 166 MHz
USB Device Clock	: 12 MHz
MAC	: 25 MHz
OPE	: 7.37 MHz

1.3 Operating mode and condition

The system was configured for testing in typical fashion use. Cable were attached to each of the available I/O port. Where applicable, peripherals were attached to the I/O cables.

This EUT is supporting the USB, Parallel and Network(LAN) printing.

In each test mode, finally we found worst case emission that is above configuration with the Worst case components(in the above table). So, the data of the maximum EUT operation, Network printing(duplex mode) was reported.

- Operating Mode

- Network Printing Mode
- **USB Printing Mode (worst emission)**
- **Standby Mode (worst emission)**

- Test Voltage : 120 V, 60 Hz

1.4 Equipment modifications

No equipment modifications were required.

1.5 Test procedure

1.5.1 Conducted emission

EUT was placed on a platform nominal size, 1 m by 1.5 m, raised 80 cm above the conducting ground plane. The rear of tabletop was located 40 cm to the vertical conducting ground plane.

The rear of EUT, including peripherals was aligned and flush with rear of tabletop.

All other surfaces of tabletop was at least 80 cm from any other grounded conducting surface.

I/O cables and AC cables that were connected to the peripherals were bundled in center.

They were folded back and forth forming a bindle 30 cm to 40 cm long and were handed at a 40 cm height to the ground plane.

Each EUT current-carrying power lead, except the ground(safety) lead, were individually connected through a LISN to the input power source.

All unused 50 ohm connectors of the LISN were resistively terminated in 50 ohm when not connected to the measuring equipment.

Frequency Band [MHz]	Instrument	Detector	Resolution Bandwidth	Video Bandwidth
0.15 to 30	EMI Receiver	Quasi-Peak	9 kHz	-
		Average	9 kHz	-

1.5.2 Radiated emission

EUT was placed on a platform of nominal size, 1 m by 1.5 m, raised 80 cm above the conducting ground plane. The rear of EUT, including peripherals was aligned and flush with rear of tabletop.

The I/O cables that were connected to the peripherals were bundle in center.

They were folded back and forth forming a bundle 30 cm to 40 cm long and were hanged 40 cm height to the ground plane.

Test was made with the antenna positioned in both the horizontal and vertical planes of polarization.

The measurement antenna was varied in height above the conducting ground plane and the turn table azimuth was varied to obtain the maximum signal strength

The system configuration, clock speed, mode of operation or video resolution, turntable azimuth with respect to the antenna were noted for each frequency found.

The spectrum was scanned from 30 to 1 000 MHz using biconiLog antenna.

Also, the EMI Receiver was scanned from 1 000 to 2 000 MHz using linearly polarization

Double ridge horn antennas were used. The explanation of measuring instrument setup when

Respective function is used in any frequency band is as following;

Frequency Band [MHz]	Instrument	Detector	Resolution Bandwidth	Video Bandwidth
30 to 1 000	EMI Receiver	Quasi-Peak	120 kHz	-
Above 1 000	EMI Receiver	Peak	1 MHz	1 MHz

1.6 Test configuration

1.6.1 Used EUT and peripherals

Seq	Device	Model Name	Serial #	Maker	FCC ID
A	Printer	CLP-610ND	-	SAMSUNG	A3LCLP610ND
B	N PC	SQ20	-	SAMSUNG	A3LNPQ20
C	AC Adaptor	AD-4212A	CNBA44XXXXXXSE3831B0241	SAMSUNG	-
D	USB Mouse	M-UV69a	HCA40801491	Logitech	Doc
E	Headset	-	-	COSY	-
F	Serial Mouse	M-CU15	LTC45000091	Logitech	DSL MCCU15

1.6.2 Used cable description

No	Connect Cable	Length [m]	Shielded [Y/N]	Remark
1	Power	1.8	No	For EUT
2	Power	1.8	No	For PC
3	USB	1.8	Yes	For PC
4	Headset	1.0	Yes	For PC
5	LAN(RJ45)	3.5	No	For EUT
6	USB	2.0	No	For PC ant EUT
7	Serial	1.8	Yes	For PC

1.6.3 Block diagram

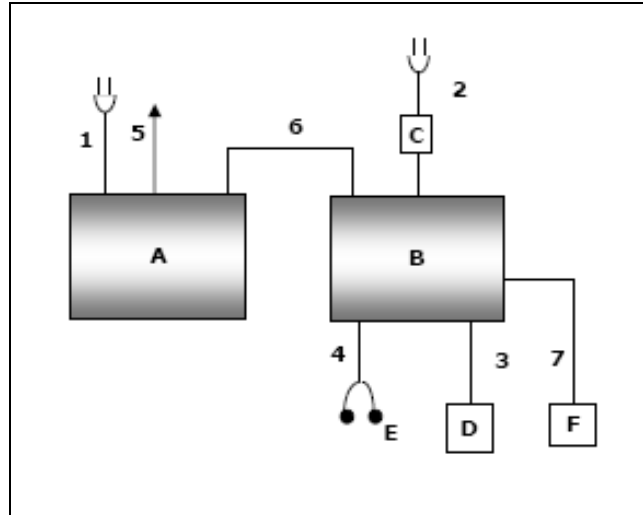

1.7 Applied Standards

Test standard	Test method
FCC Part 15 Subpart B	ANSI C63.4:2003

1.8 Test Facility

1.8.1 General information

The sites are constructed in conformance with the requirements of ANSI C63.4 and CISPR 22, 16-1, 16-2.

This EMC Testing Lab. is accredited by Korea Laboratory Accreditation Scheme(KOLAS) which signed the International Laboratory Accreditation Cooperation (ILAC) Mutual Recognition Arrangement

(MRA) for the above test item(s) and test method(s).

This Lab. is operated as testing laboratory in accordance with the requirements of ISO/IEC 17025:1998.

1.8.2 Accreditation and listing



1.8.3 Measurement uncertainty

(According to CISPR 16-4 and Lab. 34)

Test item	Measurement uncertainty
Conducted emission	± 2.8 dB
Radiated emission Horizontal	± 5.1 dB
Vertical	± 5.09 dB

2. Summary of test results

Result : PASS

The equipment under test(EUT) has been found to comply with the applied standards.

Section of the product standard		Applied standard	Test result
3.1	Conducted Emission	ANSI C63.4 : 2003	Complied
3.2	Radiated Emission	ANSI C63.4 : 2003	Complied

3. Description of individual tests

3.1 Conducted emission

3.1.1 Test information

Test engineer	Young Hun, Cheong
Test date	June 23, 2007
Climate condition	Ambient temperature : 24.2 °C, Relative humidity : 57 % Atmospheric pressure : 100.5 kPa
Test place	Shielded room # 1

3.1.2 Test equipment

Equipment	Model name	Manufacturer	Serial no.	Calibration	
				Date	Interval (Month)
EMI TEST RECEIVER	ESCI	R&S	100368	2007-06-01	12
LISN	ENV216	R&S	100116	2006-09-01	12
LISN	ESH3-Z5	R&S	100261	2006-07-21	12
Test Software	EMC 32	R&S	Ver 4.40.0	N/A	N/A

EUT Test Setup

The EUT was set up as per normal use on a wooden table, 0.4 m from a vertical ground reference plane, At least 0.8 m from other conduction surfaces and 0.8 m from the LISN.

See photo.

Test Result

Measurement Results

Pass
The measured emissions of the EUT have found to be below the specified limits.

3.1.3 Test data and graph

The initial step in collecting conducted data was to perform a peak and average scan over the measurement range using a receiver.

3.1.4.1 Test graph

- Operating Mode: Standby

Test Information

EUT Model Name :
Operating Conditions:
Operator Name:
Comment:

Hardware Setup: Voltage with ENV 2-Line-LISN - [EMI conducted]

Subrange 1

Frequency Range: 150kHz - 30MHz

Receiver: ESCI 3 [ESCI 3]
@ GPIB0 (ADR 18), SN 100368/003, FW 3.82
Signal Path: Receiver-2-Line-LISN ENV216
FW 1.0
Correction Table: Receiver-2-LISN ENV216
LISN: ENV216
Correction Table (Line 0): ENV216_100116_N
Correction Table (Line 1): ENV216_100116_L

Scan Setup: EN55022_B_ENV 2-Line-LISN fin [EMI conducted]

Hardware Setup: Voltage with ENV 2-Line-LISN
Level Unit: dB μ V

Subrange	Detectors	IF Bandwidth	Meas. Time	Receiver
150kHz - 30MHz	QuasiPeak; Average	9kHz	15s	ESCI 3

EN55022_B with ENV 2-Line-LISN

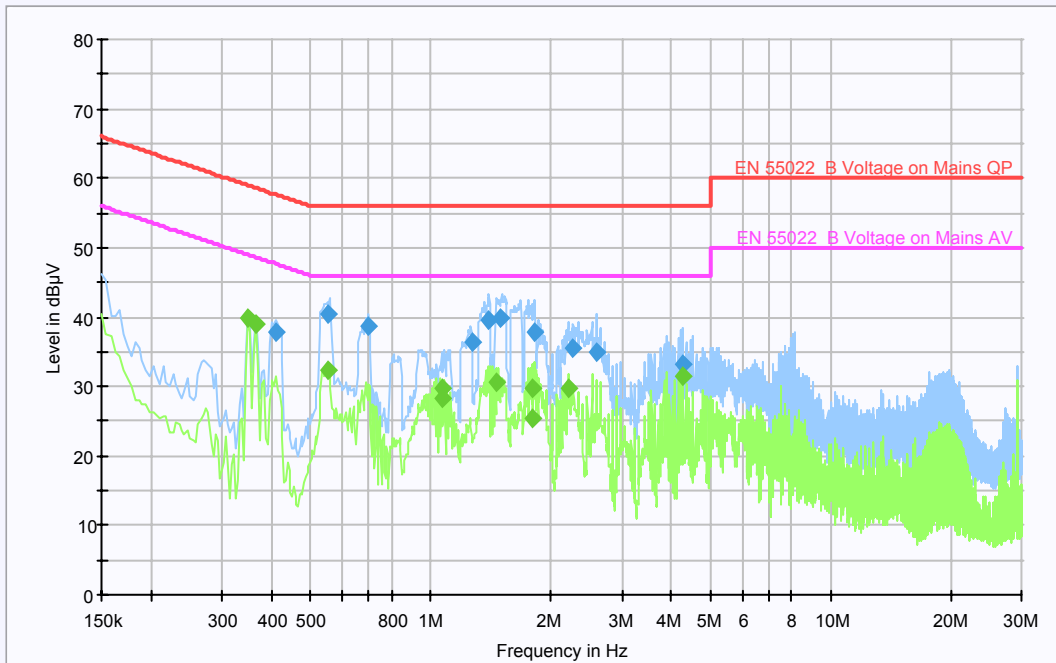

Final Measurement Detector 1

Frequency (MHz)	QuasiPeak (dB μ V)	Line	Corr. (dB)	Margin (dB)	Limit (dB μ V)
0.409 500	37.8	N	9.6	19.9	57.7
0.554 100	40.6	L1	9.6	15.4	56.0
0.699 100	38.8	N	9.6	17.2	56.0
1.262 000	36.4	N	9.6	19.6	56.0
1.398 000	39.6	N	9.7	16.4	56.0
1.492 800	39.9	N	9.7	16.1	56.0
1.813 400	37.7	L1	9.7	18.3	56.0
2.271 200	35.6	L1	9.7	20.4	56.0
2.594 400	34.9	N	9.7	21.1	56.0
4.274 200	33.3	N	9.8	22.7	56.0

Final Measurement Detector 2

Frequency (MHz)	Average (dB μ V)	Line	Corr. (dB)	Margin (dB)	Limit (dB μ V)
0.348 500	39.9	L1	9.6	9.1	49.0
0.363 700	38.9	L1	9.6	9.7	48.6
0.550 100	32.2	L1	9.6	13.8	46.0
1.063 400	29.9	N	9.6	16.1	46.0
1.064 200	28.4	N	9.6	17.6	46.0
1.457 200	30.5	N	9.7	15.5	46.0
1.792 400	25.5	N	9.7	20.5	46.0
1.793 400	29.7	L1	9.7	16.3	46.0
2.201 800	29.9	N	9.7	16.1	46.0
4.278 200	31.4	L1	9.8	14.6	46.0

* QP : Quasi-peak, AV: Average

* Level (QuasiPeak or Average) = Meter Reading(QP or AV) + Corr. (LISN Insertion loss + Cable loss)

* Margin = Limit – Result

■ Operating Mode: USB Printing

Test Information

EUT Model Name :
Operating Conditions:
Operator Name:
Comment:

Hardware Setup: Voltage with ENV 2-Line-LISN - [EMI conducted]

Subrange 1
Frequency Range: 150kHz - 30MHz

Receiver: ESCI 3 [ESCI 3]
@ GPIB0 (ADR 18), SN 100368/003, FW 3.82
Signal Path: Receiver-2-Line-LISN ENV216
FW 1.0
Correction Table: Receiver-2-LISN ENV216
LISN: ENV216
Correction Table (Line 0): ENV216_100116_N
Correction Table (Line 1): ENV216_100116_L

Scan Setup: EN55022_B_ENV 2-Line-LISN fin [EMI conducted]

Hardware Setup: Voltage with ENV 2-Line-LISN
Level Unit: dB μ V

Subrange	Detectors	IF Bandwidth	Meas. Time	Receiver
150kHz - 30MHz	QuasiPeak; Average	9kHz	15s	ESCI 3

EN55022_B with ENV 2-Line-LISN

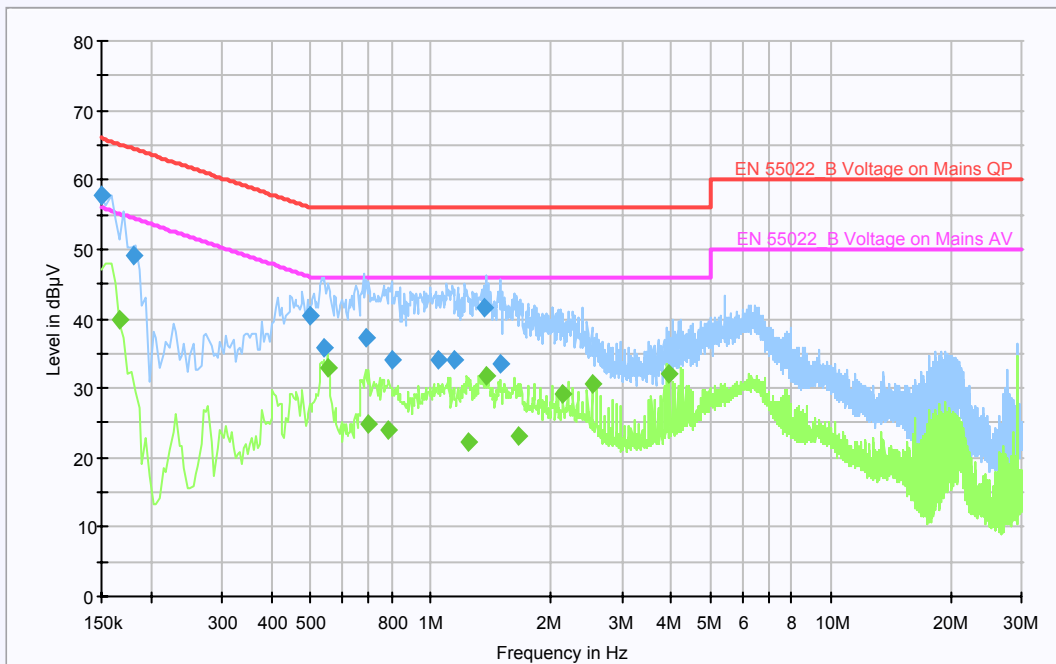

Final Measurement Detector 1

Frequency (MHz)	QuasiPeak (dB μ V)	Line	Corr. (dB)	Margin (dB)	Limit (dB μ V)
0.150 100	57.8	L1	9.6	8.2	66.0
0.180 900	49.0	L1	9.6	15.4	64.4
0.498 100	40.5	L1	9.6	15.5	56.0
0.543 300	35.7	N	9.6	20.3	56.0
0.688 100	37.3	N	9.6	18.7	56.0
0.798 100	34.1	N	9.6	21.9	56.0
1.047 900	34.1	N	9.6	21.9	56.0
1.145 200	34.0	N	9.6	22.0	56.0
1.359 200	41.7	L1	9.7	14.3	56.0
1.489 400	33.6	N	9.7	22.4	56.0

Final Measurement Detector 2

Frequency (MHz)	Average (dB μ V)	Line	Corr. (dB)	Margin (dB)	Limit (dB μ V)
0.165 900	40.0	L1	9.6	15.2	55.2
0.550 500	32.9	L1	9.6	13.1	46.0
0.695 100	24.9	N	9.6	21.1	46.0
0.783 300	24.0	N	9.6	22.0	46.0
1.246 400	22.3	N	9.6	23.7	46.0
1.378 000	31.9	L1	9.7	14.1	46.0
1.655 000	23.2	N	9.7	22.8	46.0
2.137 800	29.2	N	9.7	16.8	46.0
2.526 400	30.6	L1	9.7	15.4	46.0
3.953 600	32.1	L1	9.8	13.9	46.0

* QP : Quasi-peak, AV: Average

* Level (QuasiPeak or Average) = Meter Reading(QP or AV) + Corr. (LISN Insertion loss + Cable loss)

* Margin = Limit – Result

■ Operating Mode: Network Printing

Test Information

EUT Model Name :
Operating Conditions:
Operator Name:
Comment:

Hardware Setup: Voltage with ENV 2-Line-LISN - [EMI conducted]

Subrange 1
Frequency Range: 150kHz - 30MHz

Receiver: ESCI 3 [ESCI 3]
@ GPIB0 (ADR 18), SN 100368/003, FW 3.82
Signal Path: Receiver-2-Line-LISN ENV216
FW 1.0
Correction Table: Receiver-2-LISN ENV216
LISN: ENV216
Correction Table (Line 0): ENV216_100116_N
Correction Table (Line 1): ENV216_100116_L

Scan Setup: EN55022_B_ENV 2-Line-LISN fin [EMI conducted]

Hardware Setup: Voltage with ENV 2-Line-LISN
Level Unit: dB μ V

Subrange	Detectors	IF Bandwidth	Meas. Time	Receiver
150kHz - 30MHz	QuasiPeak; Average	9kHz	15s	ESCI 3

EN55022_B with ENV 2-Line-LISN

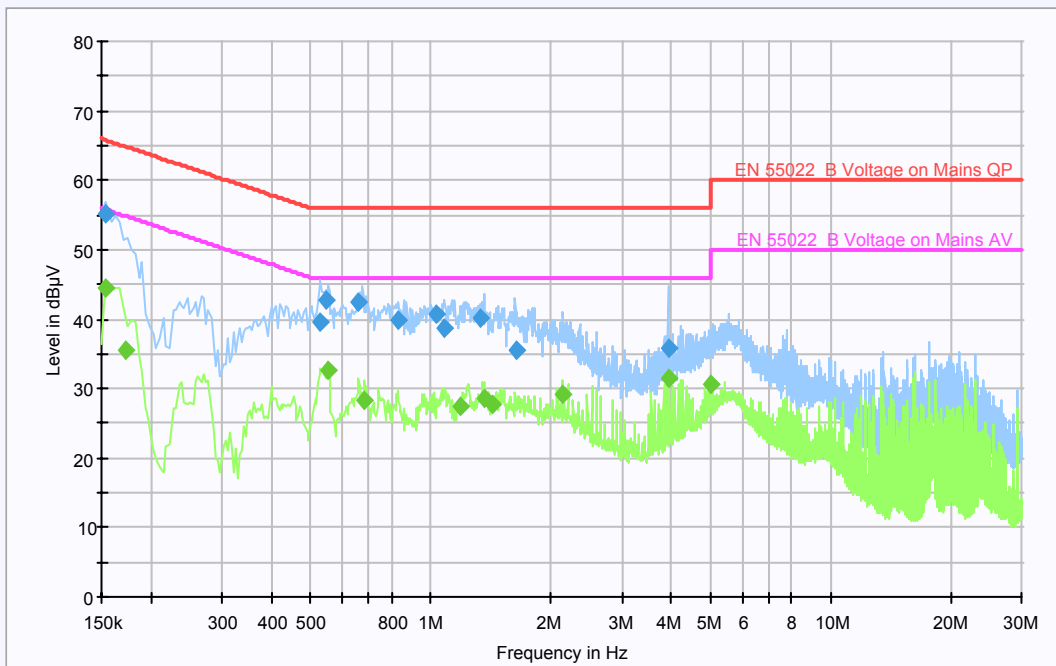

Final Measurement Detector 1

Frequency (MHz)	QuasiPeak (dB μ V)	Line	Corr. (dB)	Margin (dB)	Limit (dB μ V)
0.154 000	55.1	L1	9.6	10.7	65.8
0.527 100	39.7	N	9.6	16.3	56.0
0.547 500	42.7	L1	9.6	13.3	56.0
0.656 300	42.6	L1	9.6	13.4	56.0
0.831 300	40.0	N	9.6	16.0	56.0
1.034 000	40.6	L1	9.6	15.4	56.0
1.082 000	38.8	L1	9.6	17.2	56.0
1.324 000	40.2	N	9.6	15.8	56.0
1.634 800	35.7	N	9.7	20.3	56.0
3.952 400	35.7	N	9.7	20.3	56.0

Final Measurement Detector 2

Frequency (MHz)	Average (dB μ V)	Line	Corr. (dB)	Margin (dB)	Limit (dB μ V)
0.154 000	44.4	L1	9.6	11.4	55.8
0.172 900	35.5	N	9.6	19.3	54.8
0.550 500	32.6	N	9.6	13.4	46.0
0.677 100	28.4	L1	9.6	17.6	46.0
1.185 800	27.5	L1	9.7	18.5	46.0
1.360 000	28.5	N	9.6	17.5	46.0
1.417 400	27.6	L1	9.7	18.4	46.0
2.137 000	29.2	L1	9.7	16.8	46.0
3.953 600	31.4	L1	9.8	14.6	46.0
4.990 400	30.6	L1	9.8	15.4	46.0

* QP : Quasi-peak, AV: Average

* Level (QuasiPeak or Average) = Meter Reading(QP or AV) + Corr. (LISN Insertion loss + Cable loss)

* Margin = Limit – Result

3.2 Radiated emission

3.2.1 Test information

Test engineer	Young Hun, Cheong
Test date	June 22, 2007
Climate condition	Ambient temperature : 24.2 °C , Relative humidity : 42 % Atmospheric pressure 100.4 kPa
Test place	10 m Semi-anechoic Chamber

3.2.2 Test equipment

Equipment	Model name	Manufacturer	Serial no.	Calibration	
				Date	Interval (Month)
Bi-con Antenna	CBL6112D	SCHAFFNER	22602	2006-06-26	24
Bi-con Antenna	CBL6112D	SCHAFFNER	22601	2007-04-02	24
EMI Receiver	ESI-26	R&S	100289	2007-03-22	12
EMI Receiver	ESI-26	R&S	100287	2007-04-10	12
AMPLIFIER	310N	SONOMA	186467	2007-03-17	12
AMPLIFIER	310N	SONOMA	251673	2007-03-17	12
Ant Mast	MA4000	Inn-co	-	N/A	N/A
Ant Mast	MA4000	Inn-co	-	N/A	N/A
Mast Controller	CO2000	Inn-co	-	N/A	N/A

EUT Test Setup

EUT set up in semi-anechoic chamber. EUT positioned at 10 m from antenna in center of table.

All ports terminated into characteristic loads.

Test Result

Measurement Results	Pass The measured emissions of the EUT have found to be below the specified limits.
----------------------------	--

■ Operating Mode: **USB Printing**

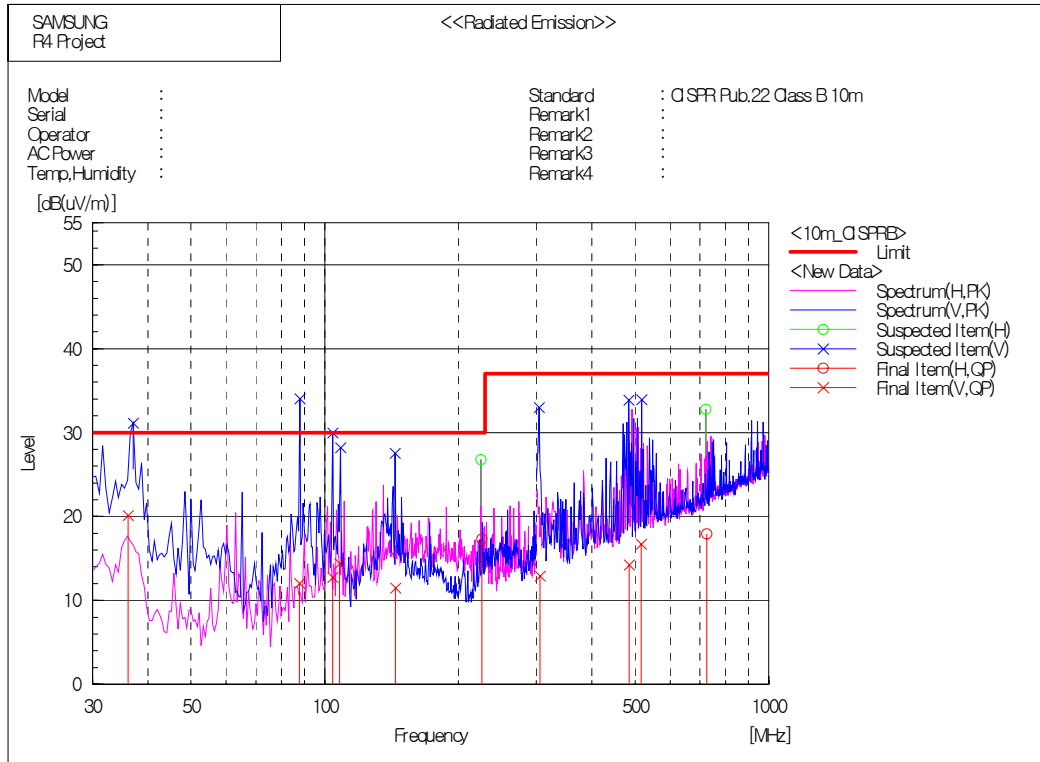

Final Result

No.	Frequency [MHz]	(P)	Reading QP [dB(uV)]	c.f [dB(1/m)]	Result QP [dB(uV/m)]	Limit [dB(uV/m)]	Margin QP [dB]	Height [cm]	Angle [deg]	System
1	36.047	V	36.6	-16.5	20.1	30.0	9.9	100.0	359.6	2
2	87.807	V	33.4	-21.3	12.1	30.0	17.9	100.0	359.6	2
3	104.277	V	31.5	-18.7	12.8	30.0	17.2	100.0	88.5	2
4	107.973	V	32.7	-18.3	14.4	30.0	15.6	100.0	8.8	2
5	144.539	V	30.1	-18.6	11.5	30.0	18.5	200.0	33.5	2
6	225.918	H	36.5	-19.2	17.3	30.0	12.7	200.0	359.6	1
7	305.282	V	27.2	-14.3	12.9	37.0	24.1	100.0	255.5	2
8	485.220	V	23.3	-9.0	14.3	37.0	22.7	400.0	336.9	2
9	515.885	V	25.3	-8.6	16.7	37.0	20.3	200.0	103.8	2
10	725.660	H	23.9	-5.9	18.0	37.0	19.0	200.0	359.6	1

- * Receiving antenna mode : Horizontal, Vertical
- * Test distance : 10m (RF Semi Anechoic Chamber)
- * Result = Reading + c.f (Antenna factor + Cable loss- Amp Gain)
- * Margin = Limit – Result

■ Operating Mode: Network Printing

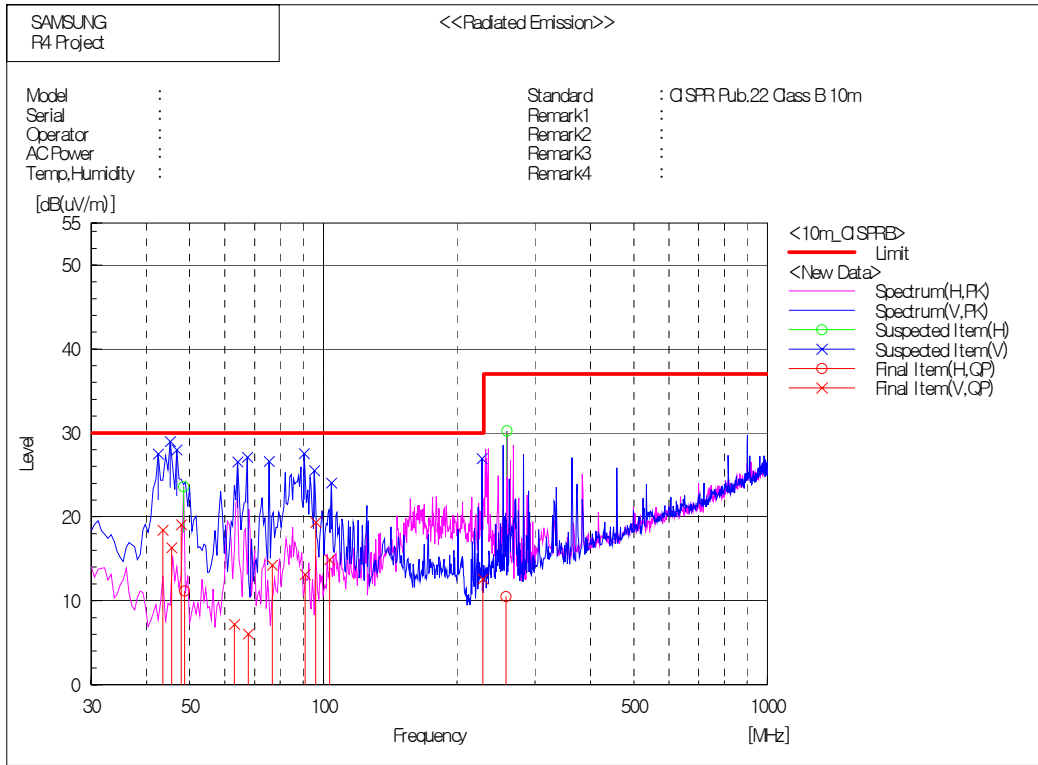

Final Result

No.	Frequency [MHz]	(P)	Reading QP [dB(uV)]	c.f [dB(1/m)]	Result QP [dB(uV/m)]	Limit [dB(uV/m)]	Margin QP [dB]	Height [cm]	Angle [deg]	System
1	43.535	V	38.8	-20.4	18.4	30.0	11.6	100.0	359.6	2
2	45.564	V	37.7	-21.4	16.3	30.0	13.7	100.0	359.6	2
3	47.810	V	41.5	-22.4	19.1	30.0	10.9	100.0	359.6	2
4	48.670	H	33.4	-22.3	11.1	30.0	18.9	400.0	359.6	1
5	62.987	V	32.2	-25.0	7.2	30.0	22.8	100.0	28.5	2
6	67.678	V	31.1	-25.0	6.1	30.0	23.9	200.0	11.9	2
7	76.801	V	38.2	-24.0	14.2	30.0	15.8	100.0	359.3	2
8	90.912	V	33.9	-20.8	13.1	30.0	16.9	300.0	255.7	2
9	95.998	V	39.3	-19.9	19.4	30.0	10.6	100.0	359.2	2
10	103.341	V	33.7	-18.8	14.9	30.0	15.1	100.0	359.2	2
11	228.623	V	31.4	-18.8	12.6	30.0	17.4	100.0	302.2	2
12	257.907	H	25.6	-15.1	10.5	37.0	26.5	200.0	359.6	1

- * Receiving antenna mode : Horizontal, Vertical
- * Test distance : 10m (RF Semi Anechoic Chamber)
- * Result = Reading + c.f (Antenna factor + Cable loss- Amp Gain)
- * Margin = Limit – Result

3.2.5 1 GHz ~ 2 GHz

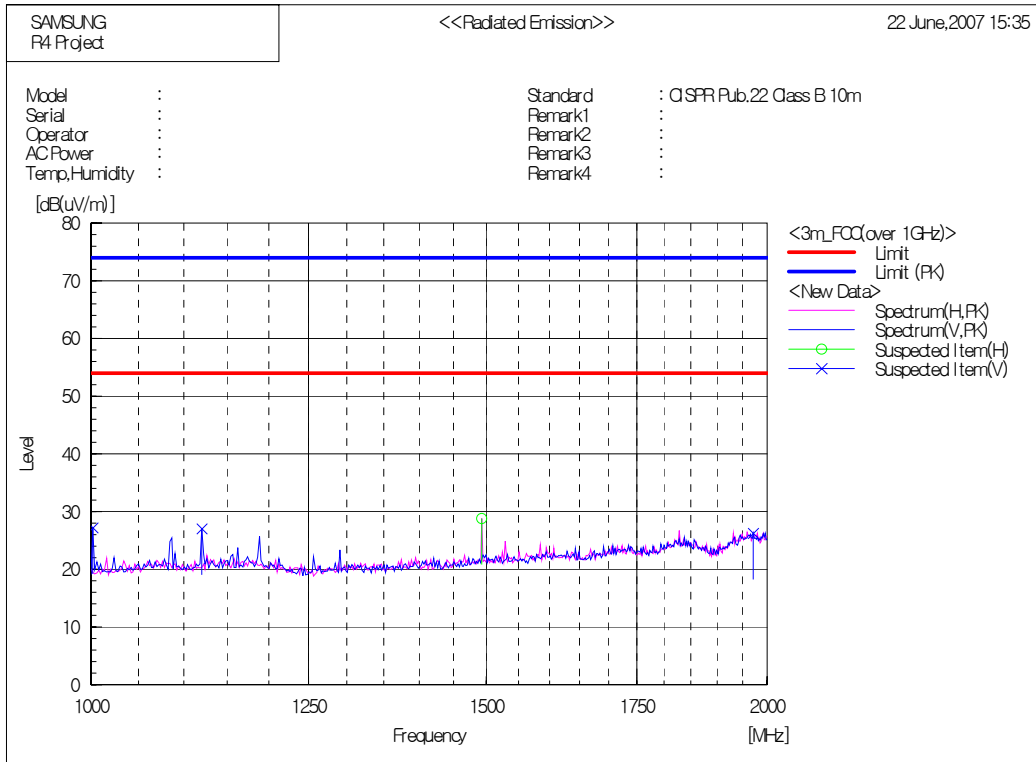

4. Appendix

4.1 Test photography



Picture 1. Conducted Emission (Front)



Picture 2. Conducted Emission (Rear)

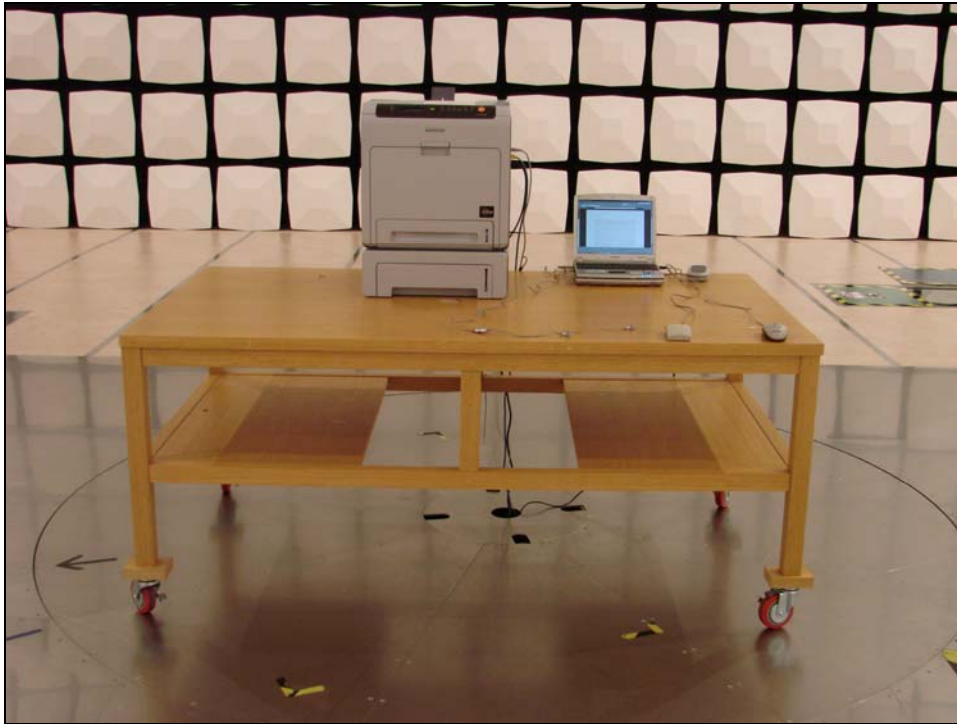

Picture 3. Radiated emission (Front)

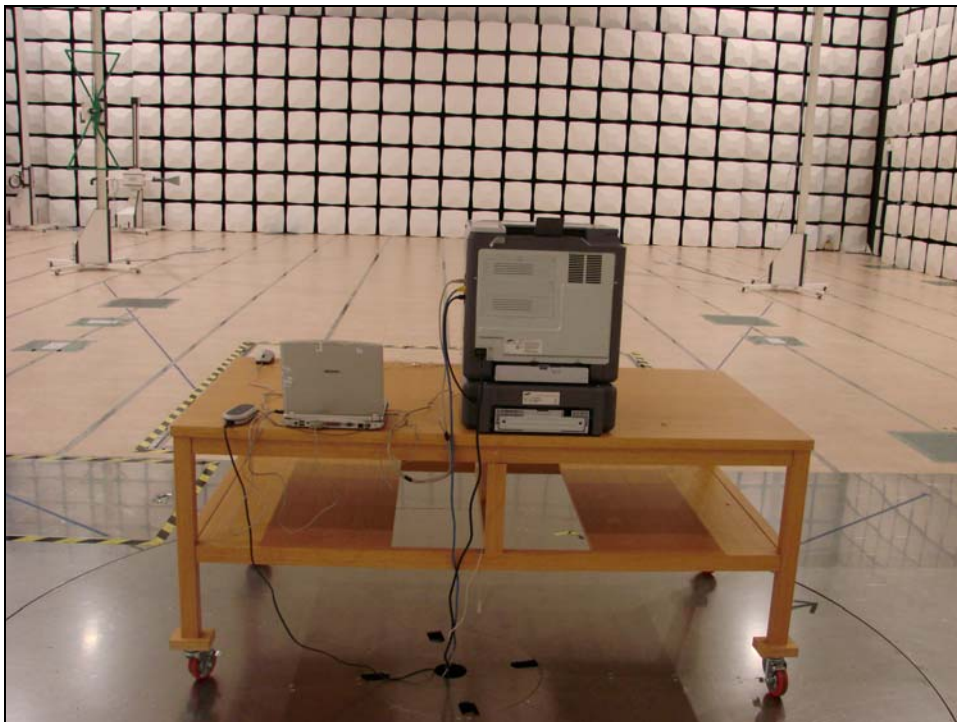

Picture 4. Radiated emission (Rear)

4.2 EUT photography



Picture 5. EUT (Front)



Picture 6. EUT (Rear)

4.3 Label and Label Location



Picture 7. Label



Picture 8. Label location