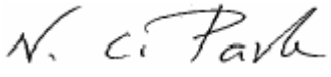
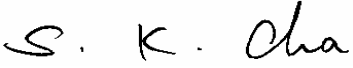

EMC Test Report

According to FCC Part 15 Subpart B

Project No.	LBE052982
Equipment under Test	
Applicant	Samsung Electronics Co., Ltd. 416 Maetan 3-Dong, Yeongtong-Gu, Suwon-Si, Gyeonggi-Do, 443-742 Korea
FCC ID	A3LCLP510N
Product Name	Laser Beam Printer
Model Name	CLP-510N
Manufacturer	Shandong Samsung Telecommunications Co., Ltd. 264209, Sanxing Road, Weihai Hi-Tech IDZ, Shandong Province, China
Date of Test	Nov 23, 2005 ~ Dec 02, 2005
Issued Date	Dec 08, 2005

	Name/Position	Signature
Tested by	Young Hun. Cheong Test Engineer	
Reviewed by	No Cheon, Park Manager of EMC Lab.	
Authorized by	Seung Kyu, Cha Chief of EMC Lab.	

1. This test reports does not constitute an endorsement by NIST/NVLAP or U.S Government.
2. This test report is to certify that the tested device properly complies with the requirements of FCC Rules and Regulations Part 15 Subpart B Unintentional Radiators.

All tests necessary to show compliance to the requirements were and these results met the specifications requirement.

This laboratory is registered by the NIST/NVLAP, U.S.A.

The test reported herein have been performed in accordance with its terms of registration.



NVLAP LAB CODE 200623-0

3. FCC filing Registration Number : 873282

Table of Contents

1. General Information

- 1.1 Basic Information related Product
- 1.2 Detail Information related Product
- 1.3 Operating mode and condition
- 1.4 Test System Details
- 1.5 Equipment Modifications
- 1.6 Test Procedure
- 1.7 Test Configuration
- 1.8 Applied Standard
- 1.9 Test Facility

2. Summary of Test Results

3. Description of individual tests

- 3.1 Conducted Emission
- 3.2 Radiated Emission

4. Appendix

- 4.1 Test Photography
- 4.2 EUT Photography

1. General Information

1.1 Basic Information related Product

Applicant	Samsung Electronics Co., Ltd.
Model name	CLP-510N
Applicant Address	416 Maetan 3-Dong, Yeongtong-Gu, Suwon-Si, Gyeonggi-Do, 443-742 Korea
Contact Person	Young Hun. Cheong
Kind of product	Laser Beam Printer
Variant List	CLP-510
Manufacturer	Shandong Samsung Telecommunications Co., Ltd. 264209, Sanxing Road, Weihai Hi-Tech IDZ, Shandong Province, China
New / Alternative / Permissive change Information	HVPS change

1.2 Detail Information related Product

Specification

Item	Specification and Description
QUALITY	"REAL 600 dpi ADDRESSABLE 1200 dpi"
RAM	"64MB SDRAM (Max 192MB) MEMORY BUS 32-BIT 60MHz"
ROM	"8MB FLASH TYPE for CODE ROM BUS 32-BIT "
HOST INTERFACE	IEEE1284(includingECP) B-TYPE USB2.0
OP PANEL	"16 x 2 LCD Panel LED 7 & Key 7 (Dual color LED in On-line key), Jam Indicator LED"
OP PANEL I/F	UART INTERFACE

FONT	GDI
OPTIONI/F	"1 SLOT for EXPANSION MEMORY 1 SLOT for NETWORK/WLAN Second cassette Feeder"

Operating Frequency

Video(23.8807363 MHz), CPU(60 MHz), LPEC(23.8807363 MHz), Main clock(12 MHz),
USB clock(30 MHz), N/W clock(25 MHz) and WLAN(2.4GHz)

1.3 Operating Mode and Condition

The system was configured for testing in typical fashion use. Cable were attached to each of the available I/O port. Where applicable, peripherals were attached to the I/O cables.

This EUT is supporting the USB, IEEE1284 and Network(LAN) printing.

In each test mode, finally we found worst case emission that is above configuration with the Worst case components(in the above table). So, the data of the maximum EUT operation, USB printing(duplex mode) was reported.

- USB Printing Mode (worst emission)

- IEEE1284 Printing Mode
- LAN Printing Mode
- WLAN Printing Mode
- Standby Mode

- Power Input

Voltage : AC 110V

Frequency : 60Hz

1.4 Test System Details

Refer to 1.2

1.5 Equipment Modifications

No equipment modifications were required.

1.6 Test Procedure

1.6.1 Conducted Emission

EUT was placed on a platform nominal size, 1 m by 1.5 m, raised 80 cm above the conducting ground plane. The rear of tabletop was located 40 cm to the vertical conducting ground plane.

The rear of EUT including peripherals was aligned and flush with rear of tabletop.

All other surfaces of tabletop was at least 80 cm from any other grounded conducting surface. I/O cables and AC cables that were connected to the peripherals were bundled in center. They were folded back and forth forming a bindle 30 cm to 40 cm long and were handed at a 40 cm height to the ground plane.

Each EUT current-carrying power lead, except the ground(safety)lead, were individually connected through a LISN to the input power source.

All unused 50 ohm connectors of the LISN were resistively terminated in 50 ohm when not connected to the measuring equipment.

Frequency Band [MHz]	Instrument	Detector	Resolution Bandwidth	Video Bandwidth
0.15 to 30	EMI Receiver	Quasi-Peak	9 kHz	-
		Average	9 kHz	-

1.6.2 Radiated Emission

EUT was placed on a platform of nominal size, 1 m by 1.5 m, raised 80 cm above the conducting ground plane.

The rear of EUT, including peripherals was aligned and flush with rear of tabletop.

I/O cables that were connected to the peripherals were bundle in center.

They were folded back and forth forming a bundle 30 cm to 40 cm long and were hanged 40 cm height to the ground plane.

Test was made with the antenna positioned in both the horizontal and vertical planes of polarization. The measurement antenna was varied in height above the conducting ground plane and the run table azimuth was varied to obtain the maximum signal strength. The system configuration, clock speed, mode of operation or video resolution, turntable azimuth with respect to the antenna were noted for each frequency found.

The spectrum was scanned from 30 MHz to 1000 MHz using biconi-Log antenna.

Frequency Band [MHz]	Instrument	Detector	Resolution Bandwidth	Video Bandwidth
30 to 1 000	EMI Receiver	Quasi-Peak	120 kHz	-
Above 1 000	EMI Receiver	Peak	1 MHz	1 MHz

1.7 Test Configuration

Used EUT and Peripherals

Mark	Item	Model No.	Serial No.	Manufacturer	Remark
A	Laser Beam Printer	CLP-510N	-	Shandong Samsung Telecommunications Co., Ltd.	FCC ID A3LCLP510N
B	Notebook PC	S950	946791CT100002	SEC	Doc
C	AC Adapter	AD-9019N	CNBA4400190ABJ6F5690702	SEC	-
D	Joystick	-	3760200731854	Microsoft	Doc
E	Serial Mouse	M-CU15	LTC45000091	Logitech	DZLMCU15
F	Headset	Axis-202	-	Labtec	-
G	PS/2 Mouse	M-SBF69	HCA42401702	SEC	Doc

Used Cable Description

No	Connect Cable	Length [m]	Shielded [Y/N]	Remark
1	Power	1.8	No	EUT
2	LAN(RJ45)	3.5	No	-
3	USB	1.8	Yes	-
4	Parallel	1.8	Yes	-
5	Power	1.8	No	Notebook PC
6	Jack	1.5	No	-
7	USB	1.5	No	-
8	Serial Mouse	1.5	No	-
9	PS/2	1.5	No	-

Block Diagram

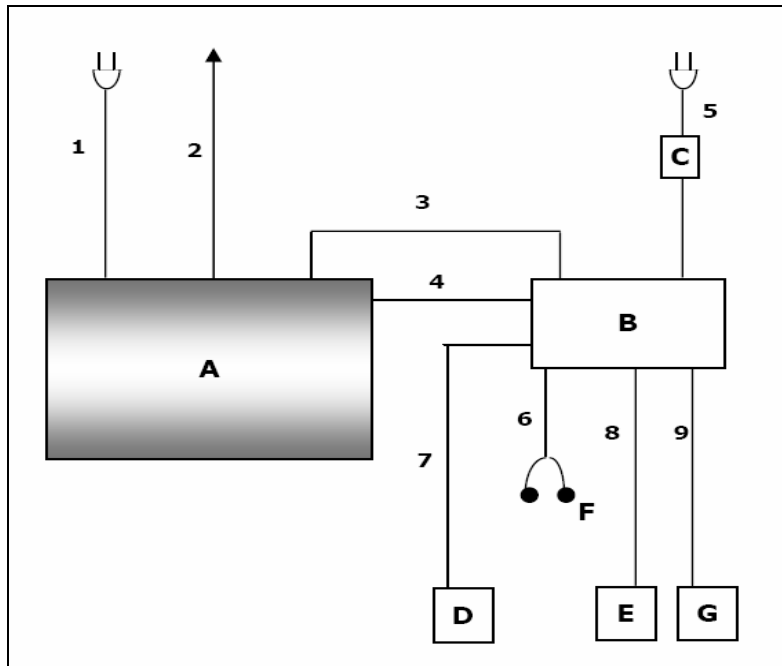

1.8 Applied Standards

List

Product or Generic Standards	Basic Standards
FCC Part15	ANSI C63.4 : 2003

1.9 Test Facility

General Information

The sites are constructed in conformance with the requirements of ANSI C63.4 and CISPR 22, 16-1, 16-2.

This EMC Testing Lab. is accredited by Korea Laboratory Accreditation Scheme(KOLAS) which signed the International Laboratory Accreditation Cooperation (ILAC) Mutual Recognition Arrangement (MRA) for the above test item(s) and test method(s).

This Lab. is operated as testing laboratory in accordance with the requirements of ISO/IEC 17025:1998.

Accreditation and Listing



Uncertainty

(According to CISPR 16-4 and Lab. 34)

Conducted Emission		: ± 3.3 dB
Radiated Emission	Bi-Log Antenna	: ± 4.3 dB

2. Summary of Test Results

Result : PASS

The equipment under test(EUT) has been found to comply with the applied standards.

Section of the Product Standard		Applied Standard	FCC Part15 Subpart B
Electromagnetic Emission Test			
3.1	Conducted Emission	ANSI C63.4 : 2003	Complied
3.2	Radiated Emission	ANSI C63.4 : 2003	Complied

3.1 Conducted Emission

Test Information	
Test Engineer	Young Hun. Cheong
Test Date	Dec 19, 2005
Climate Condition	Ambient Temperature :21.7 °C Relative Humidity : 46 %
	Atmospheric Pressure 1 019 hPa
Test Place	Shielded Room #1

Test Equipments

Equipment	Model Name	Manufacturer	Serial No.	Calibration	
				Next Date	Interval
EMI Test Receiver	ESCI	R&S	100136	2006-04-17	12
Two-Line V-Network	ENV216	R&S	100116	2006-09-08	12
Two-Line V-Network	ENV216	R&S	100117	2006-08-18	12

Measurement Results	<p>Passed</p> <p>The Measured emissions of the EUT have found to be below the specified limits.</p>
----------------------------	--

Test Data & Graph

The Initial step in collecting conducted data was to perform a peak and average scan over the measurement range using a receiver

The find data represents worst-case emissions.

* QP : Quasi-peak, AV: Average

* Level = Meter Reading(QP or AV) + Corr(LISN Insertion loss + Cable loss)

* Margin = Limit – Level

1. - TEST DATA & GRAPH

1-1. Quasi Peak Table

Frequency (MHz)	QuasiPeak (dB μ V)	Line	Corr. (dB)	Margin (dB)	Limit (dB μ V)
0.200 500	41.7	N	9.7	11.9	53.6
0.250 500	43.2	L1	9.7	8.6	51.7
1.402 500	9.7	N	9.7	36.3	46.0
1.552 500	10.7	N	9.7	35.3	46.0
1.587 500	13.7	N	9.7	32.3	46.0
1.941 500	13.0	L1	9.7	33.0	46.0
2.094 500	16.3	N	9.7	29.7	46.0
3.581 500	34.1	N	9.7	11.9	46.0
3.677 500	30.0	N	9.7	16.0	46.0

1-2. Average Table

Frequency (MHz)	Average (dB μ V)	Line	Corr. (dB)	Margin (dB)	Limit (dB μ V)
0.150 000	54.4	L1	9.6	11.6	66.0
0.200 500	48.2	L1	9.7	15.4	63.6
0.242 500	30.8	L1	9.7	31.2	62.0
0.252 500	47.8	L1	9.7	13.9	61.7
0.284 500	16.1	L1	9.7	44.6	60.7
0.312 500	19.1	N	9.7	40.8	59.9
0.347 500	28.0	L1	9.7	31.1	59.0
0.357 500	32.5	L1	9.6	26.3	58.8
0.397 500	30.2	L1	9.6	27.7	57.9
3.881 500	38.0	N	9.7	18.0	56.0

- Graph -

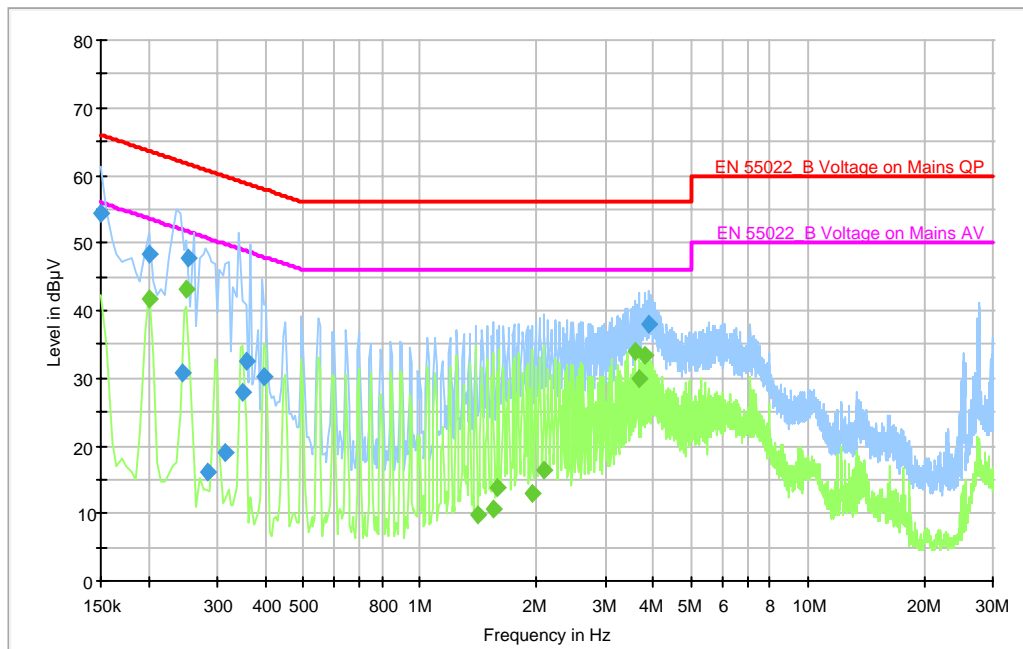

3.2 Radiated Emission

Test Information	
Test Engineer	Young Hun. Cheong
Test Date	Dec 19, 2005
Climate Condition	Ambient Temperature : 25.4 °C Relative Humidity : 34 %
	Atmospheric Pressure 1 017 hPa
Test Place	10m Semi Anechoic Chamber #1

Test Equipments

Equipment	Model Name	Manufacturer	Serial No.	Calibration	
				Next Date	Interval
EMI Test Receiver	ESI-26	R&S	100289	2006-04-11	12
EMI Test Receiver	ESI-26	R&S	100291	2006-04-12	12
Ant. Mast	MA4000	inn-co	-	N/A	N/A
Ant. Mast	MA4000	inn-co	-	N/A	N/A
Mast Controller	CO2000	inn-co	-	N/A	N/A
Amplifier	310N	SONOMA	251674	2006-03-08	12
Amplifier	310N	SONOMA	251677	2006-03-08	12
RF Selector	NS4900	TOYO	-	N/A	N/A
Bi-log Antenna	CBL6141A	SCHAFFNER	4266	2006-05-24	12
Bi-log Antenna	CBL6141A	SCHAFFNER	4268	2006-05-24	12

Measurement Results	<p>Passed</p> <p>The measured emissions of the EUT have found to be below the specified limits.</p>
----------------------------	--

Test Data & Graph

The initial step in collecting radiated data was to perform a peak scan over the measurement range using a receiver. All modes of operation were investigated and the worst-case emissions are reported. All other emission are non-significant.

The minimum margin to the limit is as follows:

All other emission are non-significant.

- * Receiving Antenna Mode : Horizontal, Vertical
- * Test distance : 10m (RF Semi Anechoic Chamber)
- * Result = Meter Reading + c.f (Antenna factor + Cable loss)
- * Margin = Limit – Result

1. Normal Running

- Graph & Data -

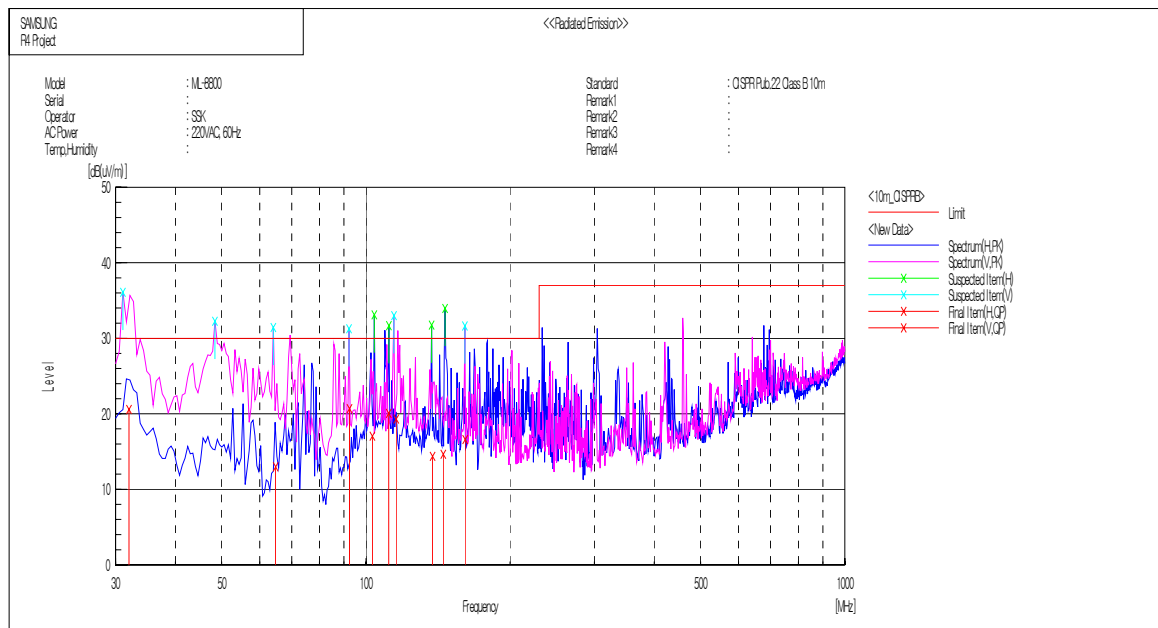

Final Result

No.	Frequency (P) [MHz]	Reading QP [dB(uV)]	c.f [dB(1/m)]	Result QP [dB(uV/m)]	Limit [dB(uV/m)]	Margin QP [dB]	Height [cm]	Angle [deg]	System	Remark
1	103.146 H	36.6	-19.6	17.0	30.0	13.0	400.0	201.3	1	
2	32.016 V	28.2	-7.6	20.6	30.0	9.4	101.0	0.7	2	
3	64.794 V	35.2	-22.2	13.0	30.0	17.0	100.0	0.7	2	
4	111.614 H	39.0	-18.9	20.1	30.0	9.9	398.0	327.9	1	
5	92.406 V	41.2	-20.5	20.7	30.0	9.3	106.0	86.0	2	
6	137.792 H	32.1	-17.7	14.4	30.0	15.6	384.0	341.9	1	
7	115.688 V	37.7	-18.4	19.3	30.0	10.7	133.0	341.9	2	
8	145.080 H	32.2	-17.6	14.6	30.0	15.4	387.0	357.6	1	
9	161.156 V	34.4	-17.8	16.6	30.0	13.4	105.0	40.5	2	

4. Appendix

4.1 Test Photography



Pic. 1 Conducted Emission (Front)



Pic. 2 Conducted Emission (Rear)

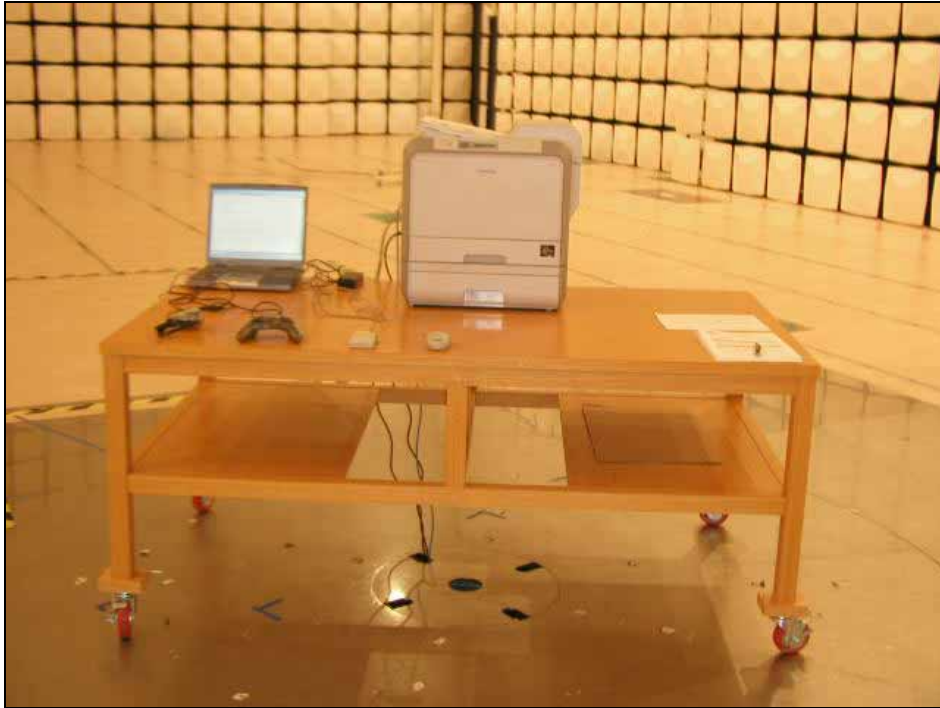

Pic. 3. Radiated Emission (Front)

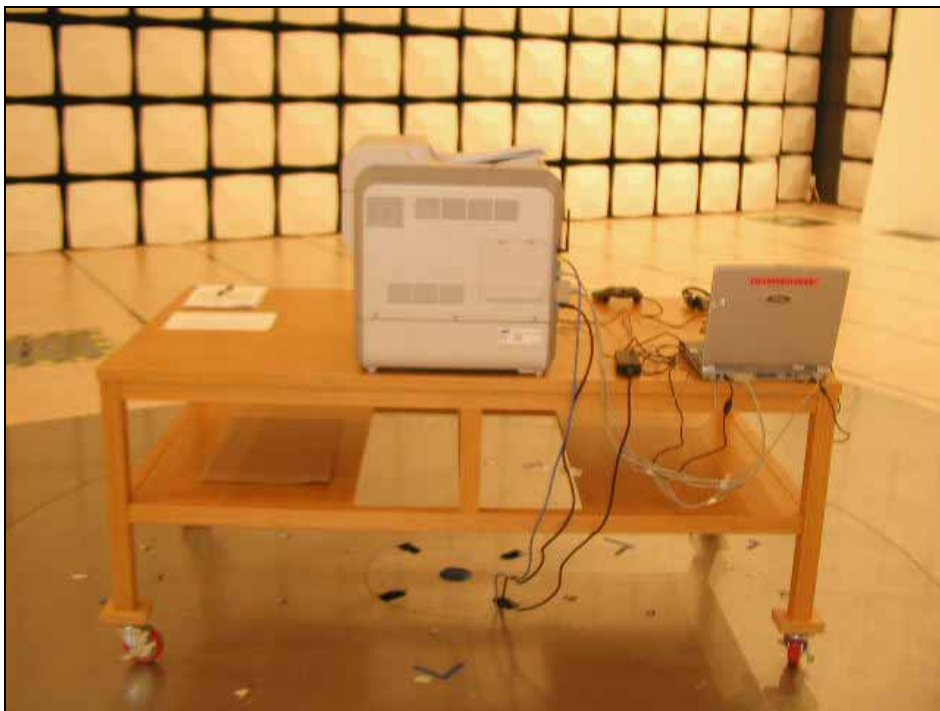

Pic. 4. Radiated Emission (Rear)

4.2 EUT Photography



Pic. 5 EUT (Front)



Pic. 6 EUT (Rear)

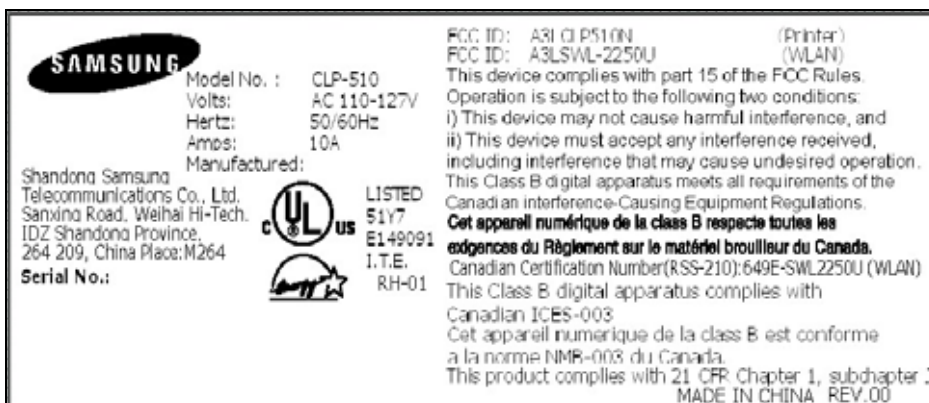
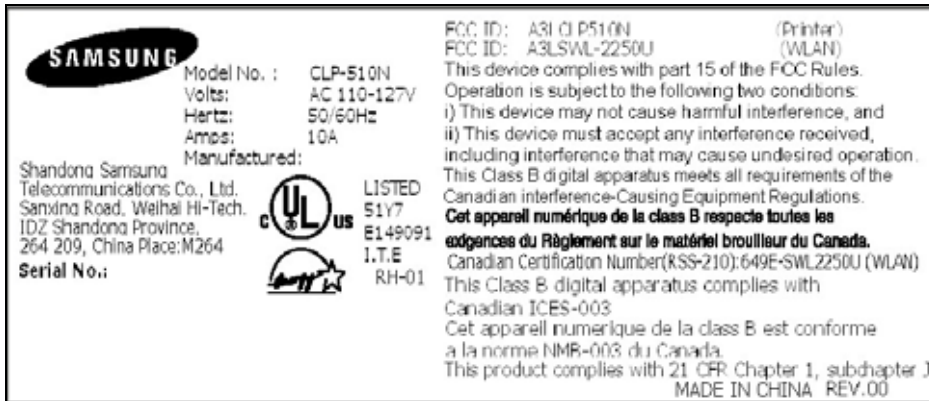

Pic. 7 EUT (Label CHINA)



Pic 8. Label location