

EMC TEST REPORT



Project No.	LBE20121724	Issue No.	0
Applicant	Name of organization	Samsung Electronics Co., Ltd.	
	Address	416 Maetan 3-Dong, Yeongtong-Gu, Suwon-Si, Gyeonggi-Do 443-742 Korea	
	Date of application	March 27, 2012	
EUT	Type of device	Class B personal computers and peripherals	
	Equipment authorization	<input type="checkbox"/> Declaration of Conformity <input checked="" type="checkbox"/> Certification <input type="checkbox"/> Verification	
	FCC ID	A3LCLP415NW	
	Kind of product	Color Printer	
	Model No.	CLP-415NW	
		Variant Model No.	CLP-415N
	Manufacturer	Samsung Electronics Co., Ltd. 259, Gongdan-Dong, Gumi-City, Gyeongsangbuk-Do, Korea 730-030 Samsung Electronics (Shandong) Digital Printing Co., Ltd. 264209, Samsung Road, Weihai Hi-Tech. IDZ, Shandong Province, P.R.China Weihai Shin Heung Digital Electronics Co., Ltd. 98, Samsung Road, Weihai Hi-Tech. IDZ, Shandong Province, P.R.China Intops : Intops (Weihai) Electronics Co., Ltd. Keji Road-268-1 , Weihai Hi-Tech,Industries Development Zone , Shandong Province , CHINA	
Applied Standards	FCC Part 15, Subpart B / ANSI C63.4-2009		
Test Period	April 21, 2012 ~ April 23, 2012		
Issue date	April 23, 2012		
Test result : Complied The equipment under test has found to be compliant with the applied standards. The result is not applied the uncertainty concept. This mean that the result is applied the original (standard) limit. (Refer to the attached test result for more detail.)			
Tested by : Young Ju Ryu 		Reviewed by : Tae Young Jang 	
The test results in this report only apply to the tested sample. This report must not be reproduced, except in full, without written permission from CS & Environment center.			
			
416 Maetan 3-Dong, Yeongtong-Gu, Suwon-Si, Gyeonggi-Do, 443-742 Korea Tel: 82 31 277 7752, Fax: 82 31 277 7753			

Table of contents

1. Report information	
1.1 Revision history	- 3 page
1.2 Sample calculation	- 3 page
2. Summary of test results	
2.1 Emission	- 3 page
3. General Information	
3.1 Test facility	- 4 page
4. Test configuration	
4.1 Test Peripherals	- 4 page
4.2 EUT operating mode	- 5 page
4.3 Details of Sampling	- 5 page
4.4 Used cable description	- 5 page
4.5 Test arrangement	- 6 page
4.6 EUT Description	- 7 page
4.7 Clock Frequencies	- 8 page
4.8 Test configuration and condition	- 8 page
4.9 Measurement uncertainty	- 9 page
5. Result of individual tests	
5.1 Conducted disturbance	- 10 page
5.2 Radiated disturbance	- 20 page

Appendix – EUT photography	- 37 page
-----------------------------------	-----------

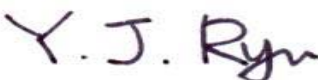
1. Report information

1.1 Revision history

No.	Revised detailed information
Issue 0	There are no revisions and this version is basic test report.

1.2 Sample calculation

1.2.1 Conducted disturbance (at 10 MHz)

- Class B limit = 60 dB μ V (Quasi-peak limit)
- Level (50 dB μ V) = Meter Reading (40.2 dB μ V) + factor (9.8 dB, AMN factor 9.7 dB + Cable loss 0.1 dB)
- Margin (10 dB) = Limit (60 dB μ V) – Level (50 dB μ V) = 10 dB below limit

1.2.2 Radiated disturbance (at 100 MHz)

- Class B limit = 30 dB μ V/m at 10 m
- Level (20 dB μ V/m)
 - = Meter Reading (40 dB μ V) + factor (- 20 dB (1/m), antenna factor + cable loss – amplifier gain)
- Margin (10 dB) = Limit (30 dB μ V/m) – Level (20 dB μ V/m) = 10 dB below limit

2. Summary of test results

2.1 Emission

The EUT has been tested according to the following specifications:

Applied	Test type	Applied standard	Result
<input checked="" type="checkbox"/>	Conducted Disturbance (Mains Port)	FCC Part 15 Subpart B / ANSI C63.4-2009	Complied
<input checked="" type="checkbox"/>	Radiated Disturbance		Complied

3. General Information

3.1 Test facility

The CS & Environment center is located on Samsung Electronics Co., Ltd. at 416 Maetan 3-Dong, Yeongtong-Gu, Suwon-Si, Gyeonggi-Do, South Korea.

All testing are performed in Semi-anechoic chambers conforming to the site attenuation Characteristics defined by ANSI C63.4, CISPR 22, 16-1 and 16-2. and Shielded rooms.

The CS & Environment center is operated as testing laboratory in accordance with the requirements of ISO/IEC 17025:2005.

4. Test Setup configuration

4.1 Test Peripherals

The cables used for these peripherals are either permanently attached by the peripheral manufacturer or coupled with an assigned cable as defined below.

The following is a listing of the EUT and peripherals utilized during the performance of EMC test:

Seq	Description	Model No.	Serial No.	Manufacturer	Fcc ID / DoC
A	COLOR PRINTER	CLP-415NW	-	Samsung	EUT
B	PC	D410	CN-0P6928-36521-518-0019	Dell	DoC
C	Adapter (For PC)	LA65NS1-00	CN-0YD637-71615-83C-0A0A	Liteon	DoC
D	USB Mouse	MOARUO	0827010021	PRIMAX electronics	DoC
E	Headset	-	-	ACTTO	-

4.2 EUT operating mode

To achieve compliance applied standard specification, the following mode(s) were made during compliance testing:

Operating Mode 1	Stand-by
Operating Mode 2	USB printing

4.3 Details of Sampling

Customer selected, single unit.

4.4 Used cable description

The EUT is configured, installed, arranged and operated in a manner consistent with typical applications. Interface cables/loads/devices are connected to at least one of each type of interface port of the EUT, and where practical, each cable shall be terminated in a device typical of actual usage. The type(s) of interconnecting cables to be used and the interface port (of the EUT) to which these were connected;

No.	Connected cable	Length [m]	Shielded [Y/N]	Note
1	Power	1.5	No	For EUT
2	Power	1.0	No	For PC
3	USB	1.8	Yes	From EUT to PC
4	LAN	2.0	No	From EUT to HUB
5	USB	1.0	Yes	From PC to Mouse
6	Headset	1.0	No	From PC to Headset

4.5 Test arrangement

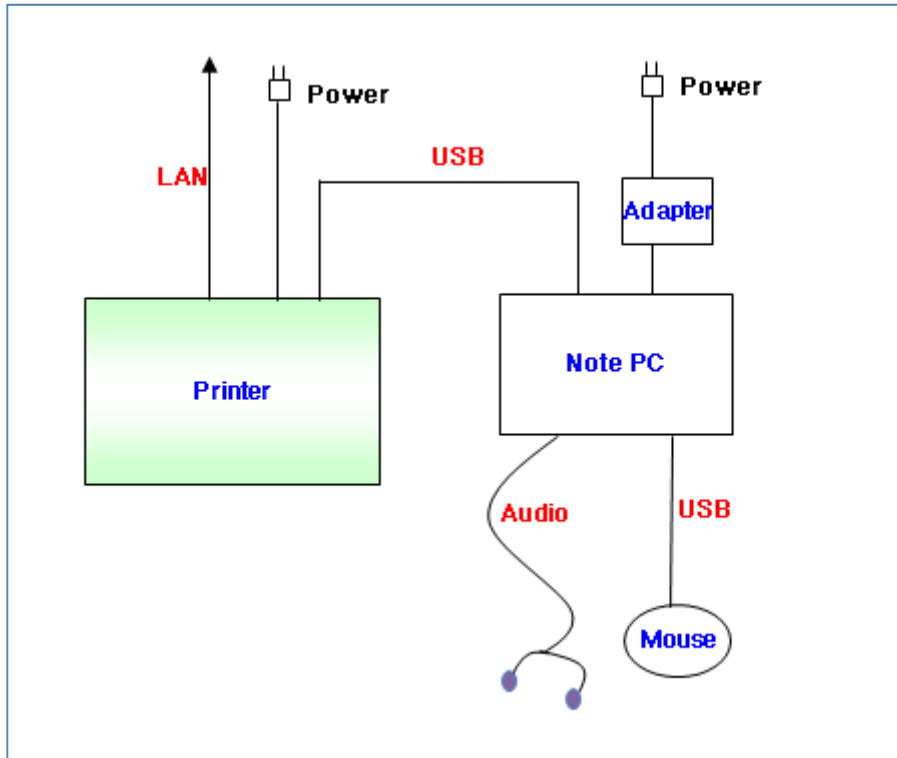

4.6 EUT Description

The following features describe EUT represented by this report:

Item	Specification and Description
Processor	CHORUS3N (533MHz)
Standard System memory	512MB DDR3 on all configurations (Default)
Resolution	Effective 2400 x 600dpi
Speed	18/18PPM (Color/Mono)
Paper Handling	Paper Tray(standard) 250 Sheets Bypass Tray 1 Sheets
Power Rating	90VAC ~ 135VAC, 4A, 50/60 Hz
Power Consumption	Power save mode : 1.5 Watts Stand by mode : 48 Watts Printing simplex : 850 Watts
Printer Language	SPLC, PCL5Ce, PCL6C, PS3, PDF V1.7
Interfaces	USB2.0, Network(Gigabit), WI-FI
OS compatibility	Windows 95/98/2000/NT4.0/Win-ME/XP/Longhorn/XP 64bit/ Citrix MAC OS 8, 9, X 10.2, X 10.3 & Higher Unix/Linux
Modes of Operation	USB Printing, Network Printing
Intended Class for Emissions	Class B

4.7 Clock Frequencies

Kind of Clocks	Frequency[MHz]	Kind of Clocks	Frequency[MHz]
CPU internal clock	533	DDR3 clock	377
Video clock	26.75	Main source clock	12
USB device clock	12		

4.8 Test configuration and condition

The system was configured for testing in typical fashion use. Cables were attached to each of the available I/O Ports. Where applicable, peripherals were attached to the I/O cables. The mode of operation utilized for testing was selected to best simulate typical EUT use.

The EUT was measured all testing with toner cartridge.

Two different types of SMPS, Dongyang and Liteon, were applied during test. Each SMPS was installed for testing, tested and reported.

- Configuration 1 : Dongyang SMPS was applied.
- Configuration 2 : Liteon SMPS was applied.

- Test Voltage : AC 120 V, 60 Hz

4.9 Measurement uncertainty

Where relevant, the following measurement uncertainty levels have been estimated for tests performed on the apparatus: (According to CISPR 16-4 and UKAS Lab 34.)

4.9.1 Emission

Test type		Measurement uncertainty (C.L. 95 %, k = 2)
Conducted disturbance	Main terminal	3.30 dB
Radiated Disturbance (Below 1 GHz)	Horizontal	5.26 dB
	Vertical	5.27 dB
Radiated Disturbance (Above 1 GHz)	Horizontal	3.40 dB
	Vertical	3.12 dB

5. Results of individual test

5.1 Conducted disturbance

Both conducted lines are measured in Quasi-Peak and Average mode, including the worst-case data points for each tested configuration. The EUT measured in accordance with the methods described in standards.

Limits for conducted disturbance at the mains ports of class B ITE

Frequency range Limits MHz	Resolution Bandwidth	Limits dB μ V	
		Quasi-peak	Average
0.15 to 0.50	9 kHz	66 to 56	56 to 46
0.50 to 5	9 kHz	56	46
5 to 30	9 kHz	60	50

NOTE 1 The lower limit shall apply at the transition frequency
 NOTE 2 The limit decreases linearly with the logarithm of the frequency in the range 0.15 MHz to 0.50 MHz.

5.1.1 Test instrumentation

Test instrumentation	Model name	Manufacturer	Serial or Firmware (No./Ver.)	Calibration	
				Date	Interval (Month)
Measuring receiver	ESIB 26	R&S	100287	2011-07-30	12
Artificial mains network	ENV216	R&S	100456	2011-09-28	12
Artificial mains network	ESH3-Z5	R&S	831887/004	2011-07-27	12
Test Software	EMC32	R&S	Ver 5.20.1	-	-

5.1.2 Temperature and humidity condition

Test date	April 23, 2012	Test engineer		Young Ju Ryu	
Climate condition	Ambient temperature	22.3 °C	Relative humidity		30 %
	Atmospheric pressure	100.3 kPa			
Test place	Shielded Room #1				

5.1.3 Photograph of Test Setup



Front



Rear

5.1.4 Test results (mains port)

- Configuration 1 : Dongyang SMPS, Stand-by mode

Hardware Setup: Voltage with ENV 2-Line-LISN - [EMI conducted]

Subrange 1
 Frequency Range: 150 kHz – 30 MHz
 Receiver: ESIB
 Transducer: ENV216 / Receiver-2-Line-LISN ENV216

Scan Setup: B_ENV 2-Line-LISN fin [EMI conducted]

Hardware Setup: Voltage with ENV 2-Line-LISN
 Level Unit: dB μ V

Subrange	Detectors	IF Bandwidth	Meas. Time	Receiver
150 kHz – 30 MHz	Quasi Peak; Average	9 kHz	15 s	ESIB

Test Graph

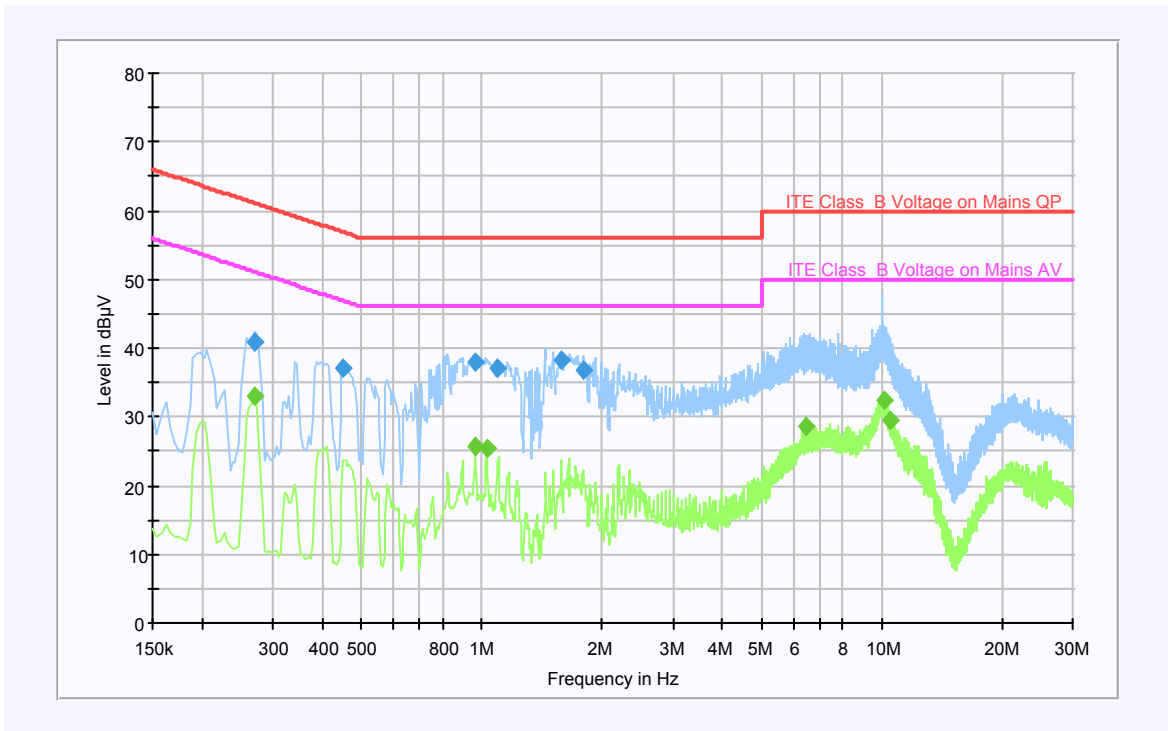

Note) Two graphs measured for both Live(L1) and Neutral(N) of the LISN are combined into one graph.

Test Results (Quasi-Peak and Average)

Quasi-peak final measurement results table

Frequency (MHz)	Quasi-Peak (dB μ V)	Line	Corr. (dB)	Margin (dB)	Limit (dB μ V)
0.270	40.9	N	9.7	20.2	61.1
0.450	36.9	N	9.7	20.0	56.9
0.962	38.0	N	9.7	18.0	56.0
1.088	37.1	N	9.7	18.9	56.0
1.580	38.2	N	9.7	17.8	56.0
1.792	36.8	N	9.7	19.2	56.0

Average final measurement results table

Frequency (MHz)	Average (dB μ V)	Line	Corr. (dB)	Margin (dB)	Limit (dB μ V)
0.270	33.1	N	9.7	18.0	51.1
0.962	25.8	N	9.7	20.2	46.0
1.028	25.5	N	9.7	20.5	46.0
6.464	28.6	N	9.7	21.4	50.0
10.112	32.3	L1	9.8	17.7	50.0
10.456	29.5	L1	9.8	20.5	50.0

Note) Level (Quasi-Peak and/or Average) = Meter Reading (Quasi-Peak and/or Average) + Factor (LISN Insertion Loss + Cable Loss)

Margin = Limit – Level (Quasi-Peak and/or Average)

- Configuration 1 : Dongyang SMPS, USB printing mode

Hardware Setup: Voltage with ENV 2-Line-LISN - [EMI conducted]

Subrange 1
 Frequency Range: 150 kHz – 30 MHz
 Receiver: ESIB
 Transducer: ENV216 / Receiver-2-Line-LISN ENV216

Scan Setup: B_ENV 2-Line-LISN fin [EMI conducted]

Hardware Setup: Voltage with ENV 2-Line-LISN
 Level Unit: dB μ V

Subrange	Detectors	IF Bandwidth	Meas. Time	Receiver
150 kHz – 30 MHz	Quasi Peak; Average	9 kHz	15 s	ESIB

Test Graph

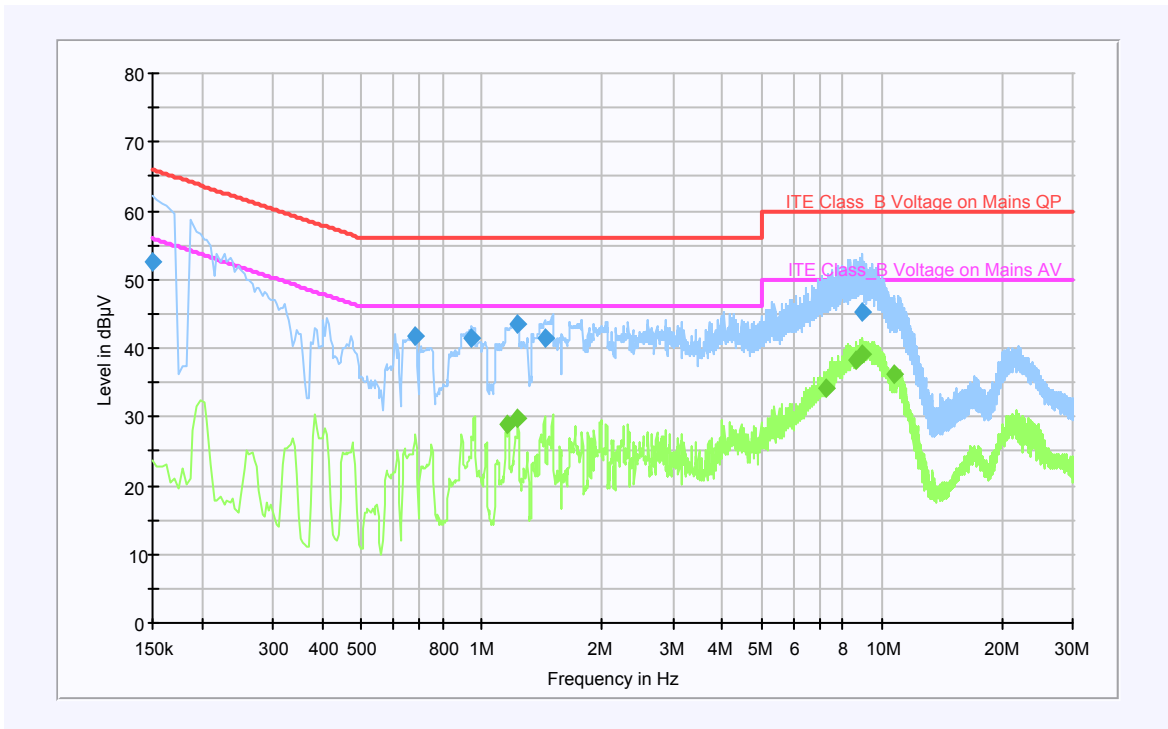

Note) Two graphs measured for both Live(L1) and Neutral(N) of the LISN are combined into one graph.

Test Results (Quasi-Peak and Average)

Quasi-peak final measurement results table

Frequency (MHz)	Quasi-Peak (dB μ V)	Line	Corr. (dB)	Margin (dB)	Limit (dB μ V)
0.150	52.5	N	9.7	13.5	66.0
0.682	41.7	N	9.7	14.3	56.0
0.942	41.6	N	9.7	14.4	56.0
1.228	43.4	N	9.7	12.6	56.0
1.436	41.3	N	9.7	14.7	56.0
8.952	45.3	N	9.8	14.7	60.0

Average final measurement results table

Frequency (MHz)	Average (dB μ V)	Line	Corr. (dB)	Margin (dB)	Limit (dB μ V)
1.160	29.0	N	9.7	17.0	46.0
1.228	29.9	N	9.7	16.1	46.0
7.244	34.3	N	9.7	15.7	50.0
8.608	38.3	N	9.8	11.7	50.0
8.948	39.1	N	9.8	10.9	50.0
10.764	36.1	L1	9.8	13.9	50.0

Note) Level (Quasi-Peak and/or Average) = Meter Reading (Quasi-Peak and/or Average) + Factor (LISN Insertion Loss + Cable Loss)

Margin = Limit – Level (Quasi-Peak and/or Average)

- Configuration 2 : Liteon SMPS, Stand-by mode

Hardware Setup: Voltage with ENV 2-Line-LISN - [EMI conducted]

Subrange 1

Frequency Range: 150 kHz – 30 MHz
 Receiver: ESIB
 Transducer: ENV216 / Receiver-2-Line-LISN ENV216

Scan Setup: B_ENV 2-Line-LISN fin [EMI conducted]

Hardware Setup: Voltage with ENV 2-Line-LISN
 Level Unit: dB μ V

Subrange	Detectors	IF Bandwidth	Meas. Time	Receiver
150 kHz – 30 MHz	Quasi Peak; Average	9 kHz	15 s	ESIB

Test Graph

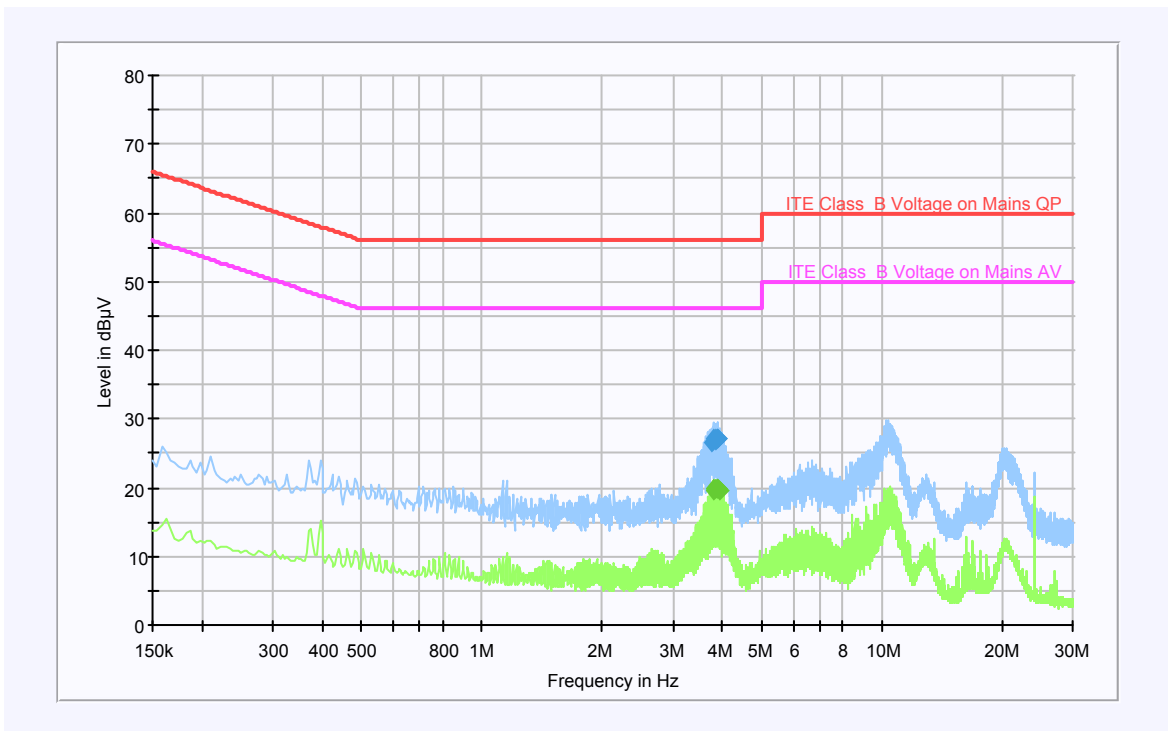

Note) Two graphs measured for both Live(L1) and Neutral(N) of the LISN are combined into one graph.

Test Results (Quasi-Peak and Average)

Quasi-peak final measurement results table

Frequency (MHz)	Quasi-Peak (dB μ V)	Line	Corr. (dB)	Margin (dB)	Limit (dB μ V)
3.736	26.7	N	9.7	29.3	56.0
3.780	27.0	N	9.7	29.0	56.0
3.828	27.3	L1	9.7	28.7	56.0
3.852	26.8	L1	9.7	29.2	56.0
3.872	27.1	L1	9.7	28.9	56.0
3.896	27.1	L1	9.7	28.9	56.0

Average final measurement results table

Frequency (MHz)	Average (dB μ V)	Line	Corr. (dB)	Margin (dB)	Limit (dB μ V)
3.780	19.7	N	9.7	26.3	46.0
3.804	19.8	N	9.7	26.2	46.0
3.828	19.8	L1	9.7	26.2	46.0
3.872	19.7	L1	9.7	26.3	46.0
3.896	19.9	L1	9.7	26.1	46.0
3.920	19.7	L1	9.7	26.3	46.0

Note) Level (Quasi-Peak and/or Average) = Meter Reading (Quasi-Peak and/or Average) + Factor (LISN Insertion Loss + Cable Loss)

Margin = Limit – Level (Quasi-Peak and/or Average)

- Configuration 2 : Liteon SMPS, USB Printing mode

Hardware Setup: Voltage with ENV 2-Line-LISN - [EMI conducted]

Subrange 1

Frequency Range: 150 kHz – 30 MHz
 Receiver: ESIB
 Transducer: ENV216 / Receiver-2-Line-LISN ENV216

Scan Setup: B_ENV 2-Line-LISN fin [EMI conducted]

Hardware Setup: Voltage with ENV 2-Line-LISN
 Level Unit: dB μ V

Subrange	Detectors	IF Bandwidth	Meas. Time	Receiver
150 kHz – 30 MHz	Quasi Peak; Average	9 kHz	15 s	ESIB

Test Graph

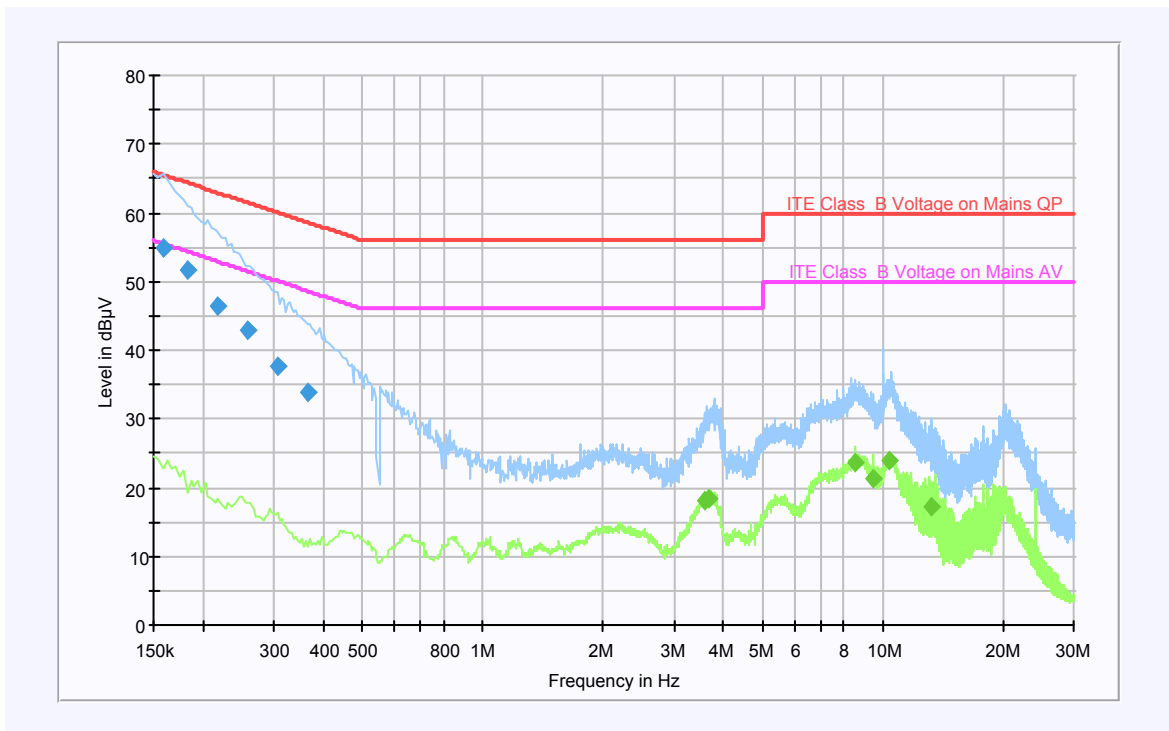

Note) Two graphs measured for both Live(L1) and Neutral(N) of the LISN are combined into one graph.

Test Results (Quasi-Peak and Average)

Quasi-peak final measurement results table

Frequency (MHz)	Quasi-Peak (dB μ V)	Line	Corr. (dB)	Margin (dB)	Limit (dB μ V)
0.158	55.0	N	9.7	10.6	65.6
0.182	51.5	N	9.7	12.9	64.4
0.218	46.4	L1	9.7	16.5	62.9
0.258	43.0	N	9.7	18.5	61.5
0.306	37.7	L1	9.7	22.4	60.1
0.366	34.0	N	9.7	24.6	58.6

Average final measurement results table

Frequency (MHz)	Average (dB μ V)	Line	Corr. (dB)	Margin (dB)	Limit (dB μ V)
3.596	18.1	L1	9.7	27.9	46.0
3.672	18.3	N	9.7	27.7	46.0
8.488	23.6	N	9.8	26.4	50.0
9.432	21.4	L1	9.8	28.6	50.0
10.432	24.0	L1	9.8	26.0	50.0
13.228	17.1	L1	9.9	32.9	50.0

Note) Level (Quasi-Peak and/or Average) = Meter Reading (Quasi-Peak and/or Average) + Factor (LISN Insertion Loss + Cable Loss)

Margin = Limit – Level (Quasi-Peak and/or Average)

5.2 Radiated disturbance

Of those disturbances above ($L - 20\text{dB}$), where L is the limit level in logarithmic units, record at least the disturbance levels and the frequencies of the six highest disturbances.

The following data lists the significant emission frequencies, measured levels, correction factors (for antenna and cables), orientation of table, polarization and height of antenna, the corrected reading, the limit, and the amount of margin.

All measurements were taken utilizing quasi-peak detection unless stated otherwise.

Measurements were performed at an antenna to EUT distance of 10 m and elevated between 1 m and 4 m.

Both vertical and horizontal antenna polarizations were measured.

Above GHz, peak detector function mode was used with resolution bandwidth of 1 MHz and a video bandwidth of 1 MHz.

If the peak measured value complies with the average limit, it is unnecessary to perform an average measurement.

Limits for radiated disturbance of ITE at a measuring distance of 10 m

Frequency range Limits MHz	Resolution Bandwidth	Quasi-peak Limits dB μ V/m
		Class B
30 to 230	120 kHz	30
230 to 1000	120 kHz	37
NOTE 1 The lower limit shall apply at the transition frequency		
NOTE 2 Additional provisions may be required for cases where interference occurs.		

Peak measurements were made over the changeable frequency range 1 GHz to 6 GHz in accordance with internal maximum operating frequency at a measurement distance of 3 m for the following antenna and turntable arrangements:

Antenna Height (cm)	Antenna Polarisation	Turntable position (degrees)
100 ~ 400	Horizontal, Vertical	Continuous

Above 1 GHz, peak detector function mode is used with a resolution bandwidth of 1 MHz and a video bandwidth of 1 MHz.

Limits for above 1GHz radiated disturbance of ITE at a measuring distance of 3 m

Class	Limits - dB(μ V/m)	
	Peak	Average
B	74	54
Average limit 500, $20 \log 500 = 53.979 \text{ dB} \approx 54 \text{ dB}$		

Antenna height was adjusted to maximum radiated position to be parallel from EUT to antenna centre.

Measurements within 20 dB of the limit were then maximized by adjusting turntable position. Final measurements were made using an average detector.

Results checked manually; and points close to the limit line were re-measured.

5.2.1 Test instrumentation

Test instrumentation	Model name	Manufacturer	Serial or Firmware (No./Ver.)	Calibration	
				Date	Interval (Month)
EMI Test Receiver	ESU	R&S	100084	2011-10-10	12
EMI Test Receiver	ESCI	R&S	100370	2011-05-29	12
Bi-log Antenna	CBL6112D	SCHAFFNER	22248	2012-02-16	24
Bi-log Antenna	CBL6112D	SCHAFFNER	27627	2011-10-07	24
Amplifier	310N	SONOMA	251673	2011-12-19	12
Amplifier	310N	SONOMA	251675	2012-01-31	12
Ant. Mast	MA4000	inn-co	-	-	-
Ant. Mast	MA4000	inn-co	-	-	-
Mast Controller	CO2000	inn-co	-	-	-
RF selector	NS4900	TOYO	-	-	-
EMI Test Receiver	ESIB	R&S	832672/002	2011-11-11	12
Horn antenna	HF907	R&S	100016	2011-06-15	24
Preamplifier	SCU18	R&S	10001	2011-05-03	12
Test Software	EP5/RE	TOYO	Ver 3.10.20	-	-

5.2.2 Temperature and humidity condition

Test date	April 21, 2012	Test engineer	Young Ju Ryu	
Climate condition	Ambient temperature	23.0 °C	Relative humidity	28 %
	Atmospheric pressure	101.6 kPa		
Test place	10 m Semi-Anechoic Chamber			

5.2.3 Photograph of Test Setup

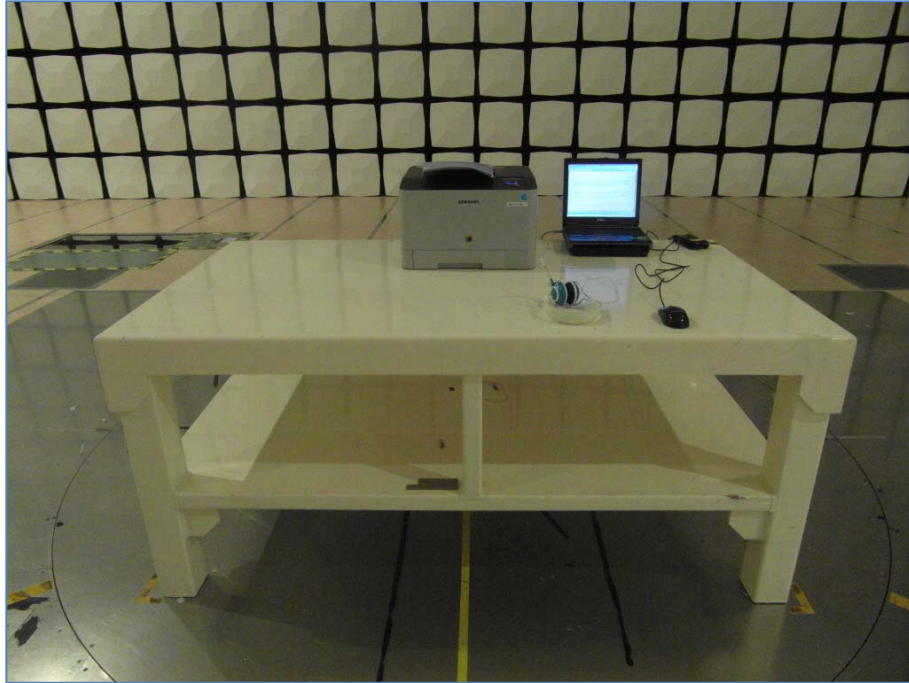

Front (Below 1GHz)

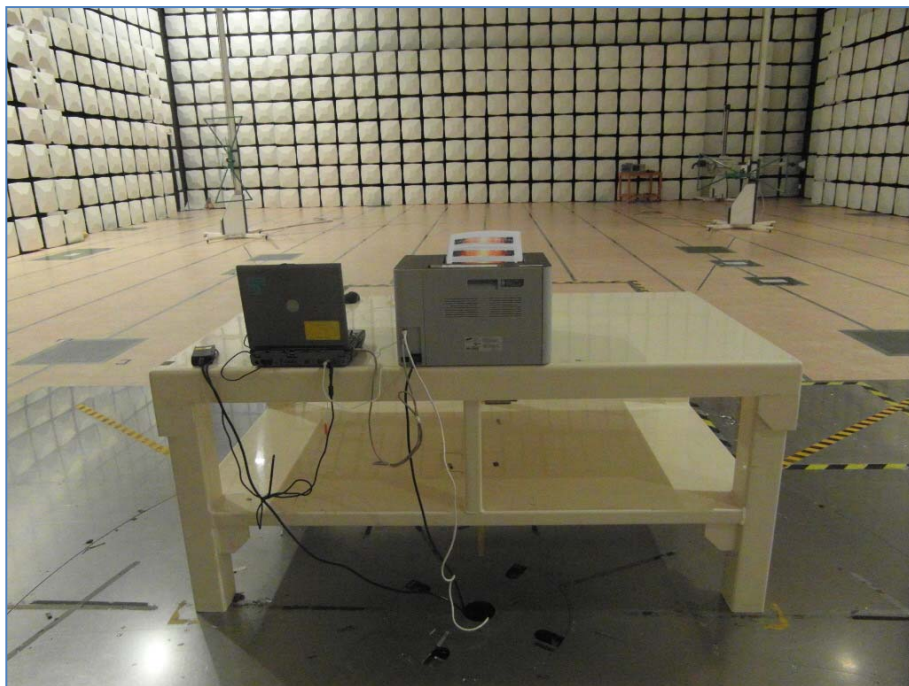

Rear (Below 1GHz)

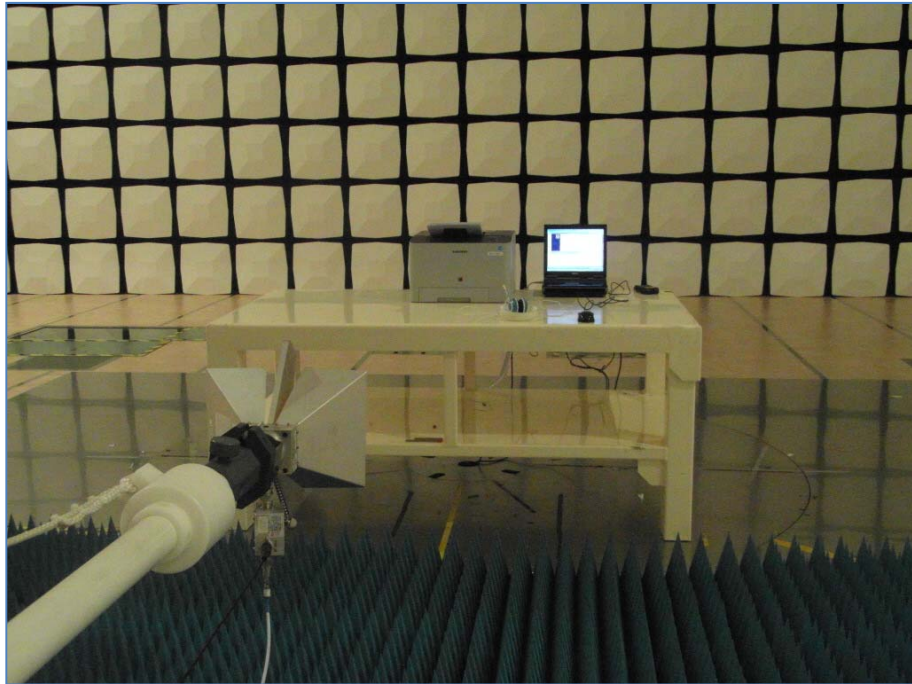

Front (above 1GHz)

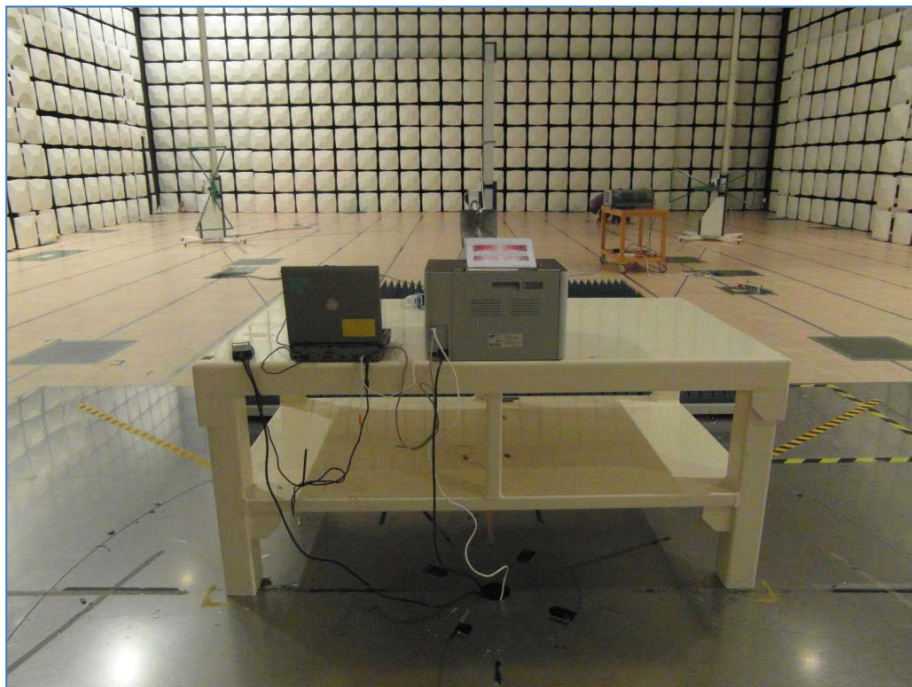

Rear (above 1GHz)

5.2.4 Test results

5.2.4.1 30 MHz to 1GHz test results

- Configuration 1 : Dongyang SMPS, Stand-by Mode

Test Graph and Results

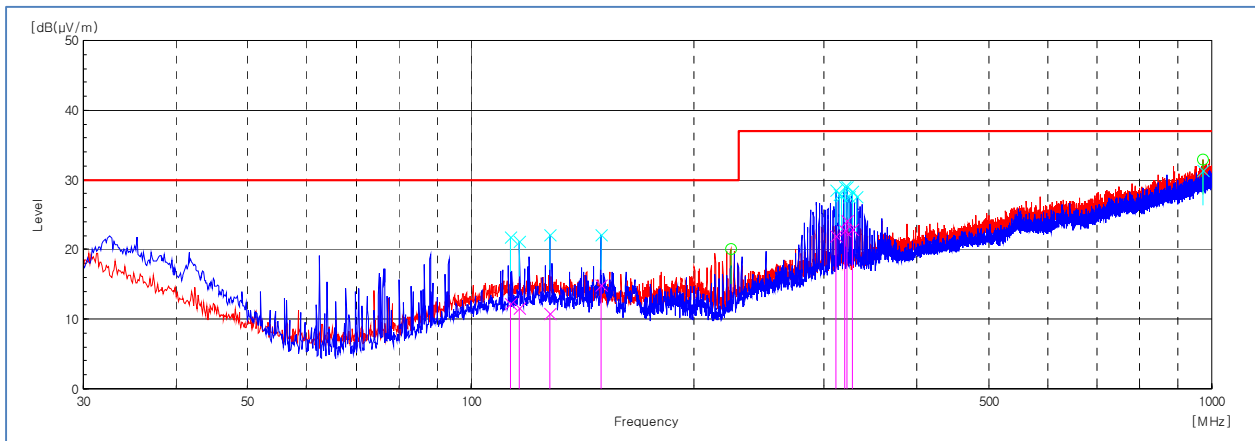

Frequency [MHz]	Pol.	Reading QP [dB(μV)]	Factor [dB(1/m)]	Level QP [dB(μV /m)]	Limit [dB(μV /m)]	Margin QP [dB]	Height [cm]	Angle [deg]
113.178	V	29.6	-17.4	12.2	30	17.8	112	33.6
116.209	V	28.8	-17.2	11.6	30	18.4	147	159.3
127.849	V	27.8	-17	10.8	30	19.2	106	52.5
149.795	V	33	-18.1	14.9	30	15.1	198	59.8
311.058	V	35.7	-13.7	22	37	15	234	228.9
319.181	V	36.1	-13.3	22.8	37	14.2	154	215
321.728	V	37.4	-13.2	24.2	37	12.8	102	228.9
327.184	V	35.9	-13	22.9	37	14.1	136	247.2

Note) Receiving antenna polarization : Horizontal and/or Vertical

Test Distance : 10 m, Antenna Height : 1 m to 4 m

Level QP (Quasi-Peak) = Reading QP + Factor (Antenna Factor + Cable Loss - Amp. Gain)

Margin QP (Quasi-Peak) = Limit – Level QP

- Configuration 1 : Dongyang SMPS, USB Printing Mode

Test Graph and Results

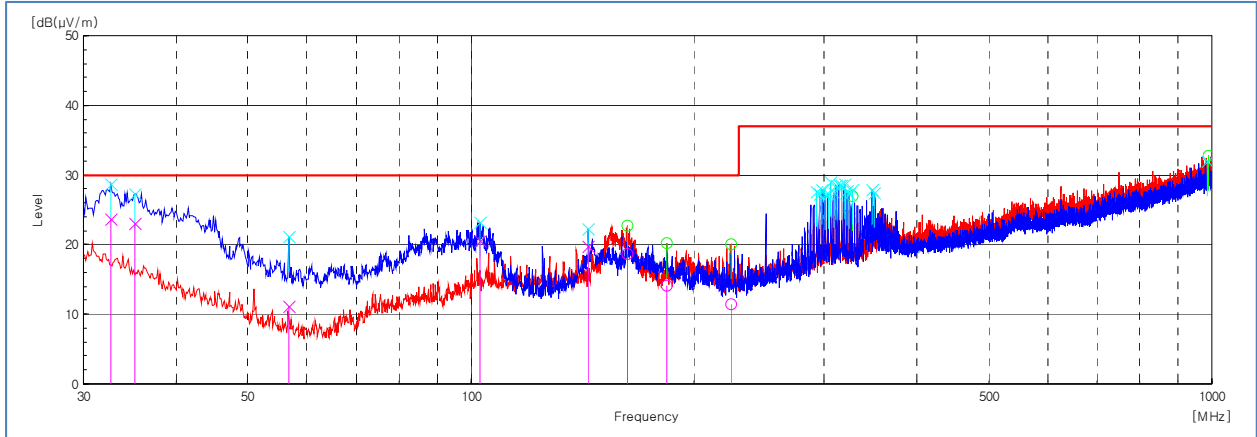

Frequency [MHz]	Pol.	Reading QP [dB(μV)]	Factor [dB(1/m)]	Level QP [dB(μV /m)]	Limit [dB(μV /m)]	Margin QP [dB]	Height [cm]	Angle [deg]
32.668	V	38.2	-14.6	23.6	30	6.4	142	344
35.214	V	39.2	-16.1	23.1	30	6.9	105	3.4
56.796	V	35.6	-24.5	11.1	30	18.9	127	31.8
102.993	V	38.8	-18.2	20.6	30	9.4	165	79
143.975	V	37.8	-18	19.8	30	10.2	145	51.2
162.526	H	36.9	-18.2	18.7	30	11.3	102	24.8
183.988	H	33.2	-19.1	14.1	30	15.9	398	169.4
224.243	H	29.5	-18	11.5	30	18.5	279	273.4

Note) Receiving antenna polarization : Horizontal and/or Vertical
 Test Distance : 10 m, Antenna Height : 1 m to 4 m
 Level QP (Quasi-Peak) = Reading QP + Factor (Antenna Factor + Cable Loss - Amp. Gain)
 Margin QP (Quasi-Peak) = Limit – Level QP

- Configuration 2 : Liteon SMPS, Stand-by Mode

Test Graph and Results

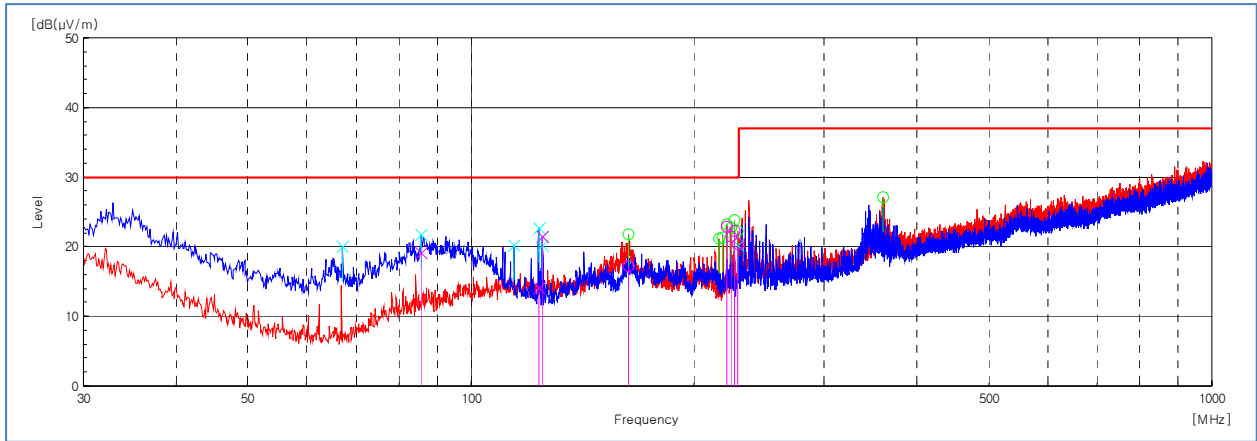

Frequency [MHz]	Pol.	Reading QP [dB(μV)]	Factor [dB(1/m)]	Level QP [dB(μV /m)]	Limit [dB(μV /m)]	Margin QP [dB]	Height [cm]	Angle [deg]
85.654	V	40.6	-21.4	19.2	30	10.8	124	1.6
123.363	V	31.1	-17	14.1	30	15.9	235	230.1
124.696	V	38.4	-16.9	21.5	30	8.5	198	178.8
163.375	H	35.5	-18.2	17.3	30	12.7	374	359.6
221.333	H	41.3	-18.4	22.9	30	7.1	104	12
224.243	H	39.5	-18	21.5	30	8.5	134	0.3
226.91	H	39.8	-17.6	22.2	30	7.8	101	345.2
229.456	H	37.7	-17.4	20.3	30	9.7	109	156.5

Note) Receiving antenna polarization : Horizontal and/or Vertical
 Test Distance : 10 m, Antenna Height : 1 m to 4 m
 Level QP (Quasi-Peak) = Reading QP + Factor (Antenna Factor + Cable Loss - Amp. Gain)
 Margin QP (Quasi-Peak) = Limit – Level QP

- Configuration 2 : Liteon SMPS, USB Printing Mode

Test Graph and Results

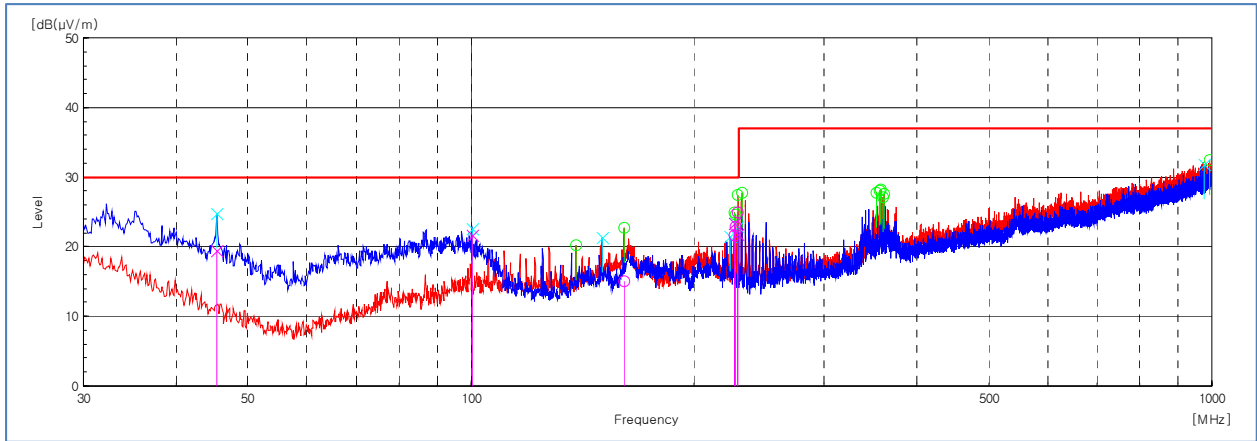

Frequency [MHz]	Pol.	Reading QP [dB(µV)]	Factor [dB(1/m)]	Level QP [dB(µV /m)]	Limit [dB(µV /m)]	Margin QP [dB]	Height [cm]	Angle [deg]
45.399	V	40.4	-21	19.4	30	10.6	102	131
100.325	V	40	-18.4	21.6	30	8.4	223	346.1
160.829	H	33.2	-18.2	15	30	15	346	343.1
226.668	H	39.2	-17.6	21.6	30	8.4	347	315.8
226.789	V	41.5	-18.2	23.3	30	6.7	110	313.3
228.001	H	40.4	-17.5	22.9	30	7.1	299	357.9
229.214	V	39.9	-18.1	21.8	30	8.2	138	266.6
229.456	H	42.3	-17.4	24.9	30	5.1	398	333.6

Note) Receiving antenna polarization : Horizontal and/or Vertical
 Test Distance : 10 m, Antenna Height : 1 m to 4 m
 Level QP (Quasi-Peak) = Reading QP + Factor (Antenna Factor + Cable Loss - Amp. Gain)
 Margin QP (Quasi-Peak) = Limit – Level QP

5.2.4.2 1 GHz to 5 GHz test results

- Configuration 1 : Dongyang SMPS, Stand-by Mode

Test Results

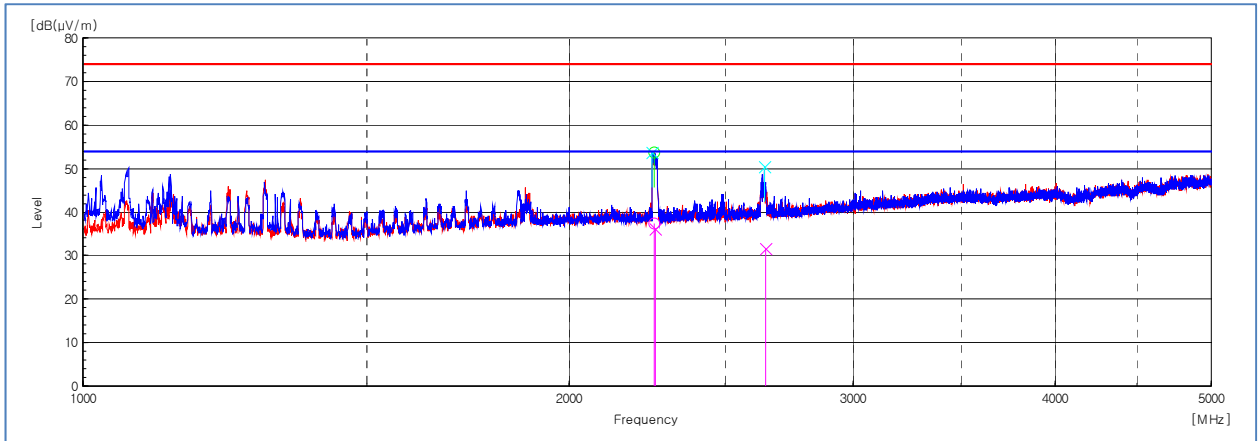

Peak Measurement

Frequency [MHz]	POL	Reading PK [dB(uV)]	Factor [dB(1/m)]	Level PK [dB(uV/m)]	Limit [dB(uV/m)]	Margin PK [dB]	Height [cm]	Angle [deg]
2253.500	V	64.1	-10.5	53.6	74	20.4	101	135.8
2260.000	H	64.1	-10.5	53.6	74	20.4	101	136.2
2642.000	V	59.9	-9.5	50.4	74	23.6	101	44.1

Average Measurement

Frequency [MHz]	POL	Reading AV [dB(uV)]	Factor [dB(1/m)]	Level AV [dB(uV/m)]	Limit [dB(uV/m)]	Margin AV [dB]	Height [cm]	Angle [deg]
2258.805	H	47.8	-10.5	37.3	54	16.7	101	135.3
2262.010	V	46.7	-10.5	36.2	54	17.8	101	135.3
2647.055	V	41	-9.5	31.5	54	22.5	101	43.7

Note 1) Representative operating modes were selected by customer and any emissions that do NOT exceed Average limit were not tested with average detector mode.

Note 2) Receiving antenna polarization : Horizontal and Vertical

Level PK (Peak) = Reading PK (Peak) + Factor (Antenna Factor + Cable Loss - Amp. Gain)

Level AV (Average) = Reading AV (Average) + Factor (Antenna Factor + Cable Loss - Amp. Gain)

Margin PK (Peak) = Limit – Level PK (Peak)

Margin AV (Average) = Limit – Level AV (Average)

- Configuration 1 : Dongyang SMPS, USB printing Mode

Test Results

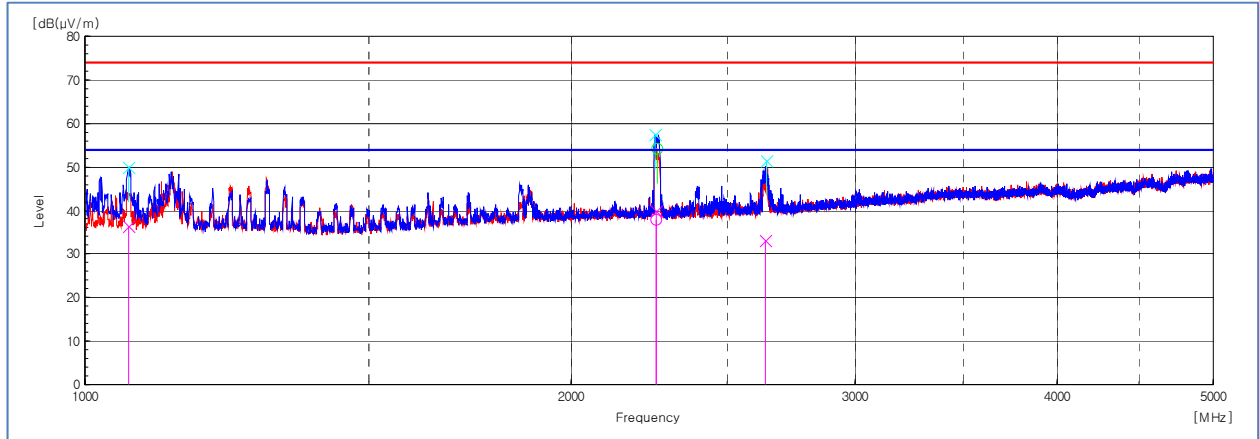

Peak Measurement

Frequency [MHz]	POL	Reading PK [dB(uV)]	Factor [dB(1/m)]	Level PK [dB(uV/m)]	Limit [dB(uV/m)]	Margin PK [dB]	Height [cm]	Angle [deg]
1063.500	V	64.6	-14.8	49.8	74	24.2	101	338.1
2256.000	V	67.8	-10.5	57.3	74	16.7	199	76.8
2263.500	H	64.7	-10.5	54.2	74	19.8	101	139.8
2645.000	V	60.9	-9.5	51.4	74	22.6	101	67.9

Average Measurement

Frequency [MHz]	POL	Reading AV [dB(uV)]	Factor [dB(1/m)]	Level AV [dB(uV/m)]	Limit [dB(uV/m)]	Margin AV [dB]	Height [cm]	Angle [deg]
1063.950	V	51.2	-14.8	36.4	54	17.6	102	337.6
2258.640	H	48.5	-10.5	38	54	16	102	139.3
2259.545	V	50.5	-10.5	40	54	14	198	76.4
2639.275	V	42.6	-9.5	33.1	54	20.9	101	67.4

Note 1) Representative operating modes were selected by customer and any emissions that do NOT exceed Average limit were not tested with average detector mode.

Note 2) Receiving antenna polarization : Horizontal and Vertical

Level PK (Peak) = Reading PK (Peak) + Factor (Antenna Factor + Cable Loss - Amp. Gain)

Level AV (Average) = Reading AV (Average) + Factor (Antenna Factor + Cable Loss - Amp. Gain)

Margin PK (Peak) = Limit – Level PK (Peak)

Margin AV (Average) = Limit – Level AV (Average)

- Configuration 2 : Liteon SMPS, Stand-by Mode

Test Results

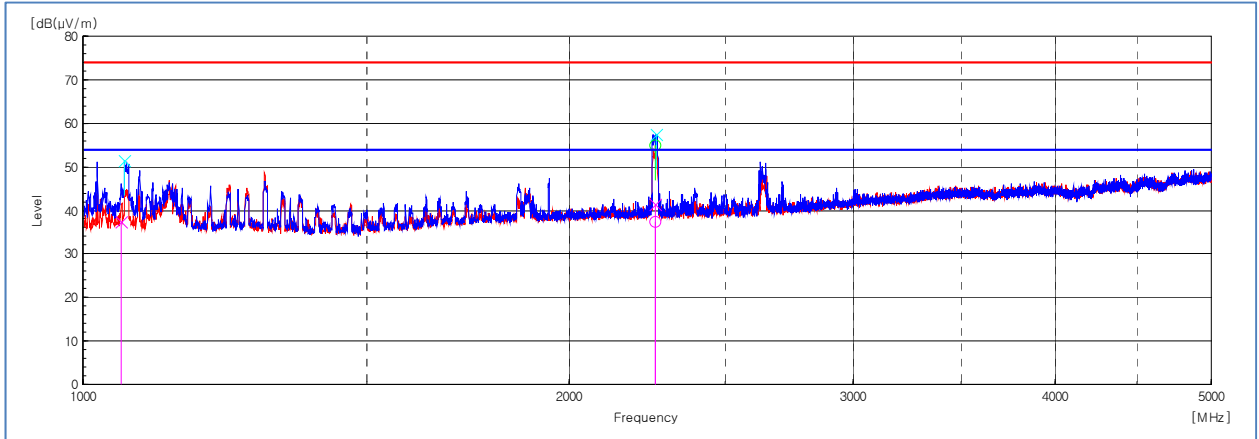

Peak Measurement

Frequency [MHz]	POL	Reading PK [dB(uV)]	Factor [dB(1/m)]	Level PK [dB(uV/m)]	Limit [dB(uV/m)]	Margin PK [dB]	Height [cm]	Angle [deg]
1061.500	V	66.2	-14.8	51.4	74	22.6	101	347.7
2262.00	H	65.3	-10.5	54.8	74	19.2	101	133.1
2264.500	V	67.9	-10.5	57.4	74	16.6	199	72.1

Average Measurement

Frequency [MHz]	POL	Reading AV [dB(uV)]	Factor [dB(1/m)]	Level AV [dB(uV/m)]	Limit [dB(uV/m)]	Margin AV [dB]	Height [cm]	Angle [deg]
1055.925	V	52.2	-14.9	37.3	54	16.7	101	348.2
2261.695	H	47.7	-10.5	37.2	54	16.8	101	133.5
2261.935	V	51.8	-10.5	41.3	54	12.7	198	72.5

Note 1) Representative operating modes were selected by customer and any emissions that do NOT exceed Average limit were not tested with average detector mode.

Note 2) Receiving antenna polarization : Horizontal and Vertical

Level PK (Peak) = Reading PK (Peak) + Factor (Antenna Factor + Cable Loss - Amp. Gain)

Level AV (Average) = Reading AV (Average) + Factor (Antenna Factor + Cable Loss - Amp. Gain)

Margin PK (Peak) = Limit – Level PK (Peak)

Margin AV (Average) = Limit – Level AV (Average)

- Configuration 2 : Liteon SMPS, USB printing Mode

Test Results

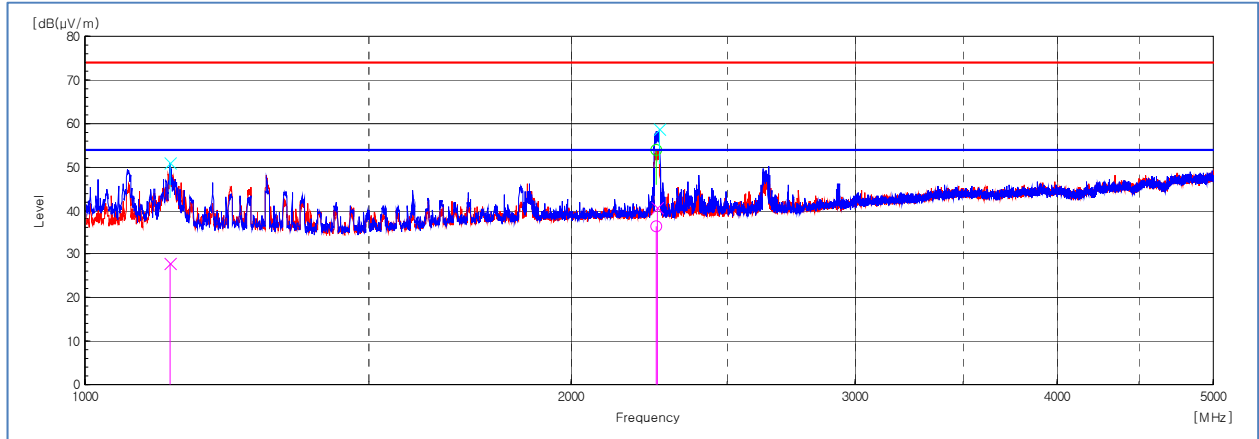

Peak Measurement

Frequency [MHz]	POL	Reading PK [dB(uV)]	Factor [dB(1/m)]	Level PK [dB(uV/m)]	Limit [dB(uV/m)]	Margin PK [dB]	Height [cm]	Angle [deg]
1128.500	V	65.6	-14.6	51	74	23	199	91.4
2260.500	H	64.4	-10.5	53.9	74	20.1	100	139.5
2270.500	V	69.2	-10.5	58.7	74	15.3	199	75.5

Average Measurement

Frequency [MHz]	POL	Reading AV [dB(uV)]	Factor [dB(1/m)]	Level AV [dB(uV/m)]	Limit [dB(uV/m)]	Margin AV [dB]	Height [cm]	Angle [deg]
1129.585	V	42.5	-14.6	27.9	54	26.1	198	90.9
2259.875	H	46.9	-10.5	36.4	54	17.6	101	139.1
2261.520	V	51.2	-10.5	40.7	54	13.3	198	75



Note 1) Representative operating modes were selected by customer and any emissions that do NOT exceed Average limit were not tested with average detector mode.

Note 2) Receiving antenna polarization : Horizontal and Vertical

Level PK (Peak) = Reading PK (Peak) + Factor (Antenna Factor + Cable Loss - Amp. Gain)

Level AV (Average) = Reading AV (Average) + Factor (Antenna Factor + Cable Loss - Amp. Gain)

Margin PK (Peak) = Limit – Level PK (Peak)

Margin AV (Average) = Limit – Level AV (Average)

Appendix – EUT photography



Front View



Rear View & Label location



Top View



Bottom View



Right View



Left View



Inside View(Left side)



Inside View(Right side)



Inside View(Front side)



Inside View(Rear side)



	<p>Model: CLP-415NW Volts: AC 110-127V Hertz: 50/60 Hz Amps: 8A Manufactured:</p>	<p>FCC ID : A3LCLP415NW Contains FCC ID : A3LSPWB4319U This device complies with part 15 of the FCC Rules. Operation is subject to the following two conditions: i) This device may not cause harmful interference, and ii) This device must accept any interference received, including interference that may cause undesired operation. Contains IC : 649E-SPWB4319U This Class B digital apparatus complies with Canadian ICES-003 Cet appareil numérique de la classe B est Conforme à la norme NMB-003 du Canada. This product complies with 21 CFR Chapter 1, subchapter J.</p>
<p>Samsung Electronics Co., Ltd. Suwon, Korea, 443-742 Place: M264</p>	<p>3UU7 E337632 I.T.E.</p>	<p>Made in China Fabriqué en Chine</p>
<p>Serial No.</p>		<p>REV.00</p>

Label