

EMC TEST REPORT

Project No.	LBE20122331	Issue No.	0
Applicant	Name of organization	Samsung Electronics Co., Ltd.	
	Address	416 Maetan 3-Dong, Yeongtong-Gu, Suwon-Si, Gyeonggi-Do 443-742 Korea	
	Date of application	April 02, 2012	
EUT	Type of device	Class B personal computers and peripherals	
	Equipment authorization	<input type="checkbox"/> Declaration of Conformity <input checked="" type="checkbox"/> Certification <input type="checkbox"/> Verification	
	FCC ID	A3LCLP365W	
	Kind of product	Color laser printer	
	Model No.	CLP-365W	
		Variant Model No.	CLP-360W
	Manufacturer	Samsung Electronics Co., Ltd. 259, Gongdan-Dong, Gumi-City, Gyeongsangbuk-Do, Korea 730-030 Samsung Electronics (Shandong) Digital Printing Co., Ltd. 264209, Samsung Road, Weihai Hi-Tech. IDZ, Shandong Province, P.R.China Weihai Shin Heung Digital Electronics Co., Ltd. 98, Samsung Road, Weihai Hi-Tech. IDZ, Shandong Province, P.R.China Intops : Intops (Weihai) Electronics Co., Ltd. Keji Road-268-1 , Weihai Hi-Tech, Industries Development Zone , Shandong Province , CHINA	
Applied Standards	FCC Part 15, Subpart B / ANSI C63.4-2009		
Test Period	May 2, 2012 ~ May 3, 2012		
Issue date	May 3, 2012		

Test result : Complied

The equipment under test has found to be compliant with the applied standards.
 The result is not applied the uncertainty concept.
 This mean that the result is applied the original (standard) limit.
 (Refer to the attached test result for more detail.)

Tested by : Sung Jin Sim



Reviewed by : Tae Young Jang



The test results in this report only apply to the tested sample. This report must not be reproduced, except in full, without written permission from CS & Environment center.



416 Maetan 3-Dong, Yeongtong-Gu, Suwon-Si, Gyeonggi-Do, 443-742 Korea
 Tel: 82 31 277 7752, Fax: 82 31 277 7753

Table of contents

1. Report information	
1.1 Revision history	3 page
1.2 Sample calculation	3 page
2. Summary of test results	
2.1 Emission	3 page
3. General Information	
3.1 Test facility	4 page
4. Test configuration	
4.1 Test Peripherals	4 page
4.2 EUT operating mode	5 page
4.3 Details of Sampling	5 page
4.4 Used cable description	5 page
4.5 Test arrangement	6 page
4.6 EUT Description	7 page
4.7 Clock Frequencies	8 page
4.8 Test configuration and condition	8 page
4.9 Measurement uncertainty	9 page
5. Result of individual tests	
5.1 Conducted disturbance	10 page
5.2 Radiated disturbance	18 page

1. Report information

1.1 Revision history

No.	Revised detailed information
Issue 0	There are no revisions and this version is basic test report.

1.2 Sample calculation

1.2.1 Conducted disturbance (at 10 MHz)

- Class B limit = 60 dB μ V (Quasi-peak limit)
- Level (50 dB μ V) = Meter Reading (40.2 dB μ V) + factor (9.8 dB, AMN factor 9.7 dB + Cable loss 0.1 dB)
- Margin (10 dB) = Limit (60 dB μ V) – Level (50 dB μ V) = 10 dB below limit

1.2.2 Radiated disturbance (at 100 MHz)

- Class B limit = 30 dB μ V/m at 10 m
- Level (20 dB μ V/m)
 - = Meter Reading (40 dB μ V) + factor (- 20 dB (1/m), antenna factor + cable loss – amplifier gain)
- Margin (10 dB) = Limit (30 dB μ V/m) – Level (20 dB μ V/m) = 10 dB below limit

2. Summary of test results

2.1 Emission

The EUT has been tested according to the following specifications:

Applied	Test type	Applied standard	Result
<input checked="" type="checkbox"/>	Conducted Disturbance (Mains Port)	FCC Part 15 Subpart B / ANSI C63.4-2009	Complied
<input checked="" type="checkbox"/>	Radiated Disturbance		Complied

3. General Information

3.1 Test facility

The CS & Environment center is located on Samsung Electronics Co., Ltd. at 416 Maetan 3-Dong, Yeongtong-Gu, Suwon-Si, Gyeonggi-Do, South Korea.

All testing are performed in Semi-anechoic chambers conforming to the site attenuation Characteristics defined by ANSI C63.4, CISPR 22, 16-1 and 16-2. and Shielded rooms.

The CS & Environment center is operated as testing laboratory in accordance with the requirements of ISO/IEC 17025:2005.

4. Test Setup configuration

4.1 Test Peripherals

The cables used for these peripherals are either permanently attached by the peripheral manufacturer or coupled with an assigned cable as defined below.

The following is a listing of the EUT and peripherals utilized during the performance of EMC test:

Seq	Description	Model No.	Serial No.	Manufacturer	Fcc ID / DoC
A	Color laser printer	CLP-365W	-	Samsung	EUT
B	PC	NT-P530	ZSV293BZ600309F	Samsung	DoC
C	Adapter	AD-6019R	CNBA4400242ABZ0415E0476	DELTA Electronics	DoC
D	USB keyboard	SK-8115	CN-OJ4636-71616-641-0GIY	Dell	DoC
E	USB mouse	Moaruo	0828008615	Primax Electronics	DoC
F	Monitor	SP2208WFpt	CN-0PK977-71618-838-106S	DELL	DoC
G	Headset	-	-	ACTTO	-

4.2 EUT operating mode

To achieve compliance applied standard specification, the following mode(s) were made during compliance testing:

Operating Mode 1	Stand-by
Operating Mode 2	USB printing
Operating Mode 3	Network printing

4.3 Details of Sampling

Customer selected, single unit.

4.4 Used cable description

The EUT is configured, installed, arranged and operated in a manner consistent with typical applications. Interface cables/loads/devices are connected to at least one of each type of interface port of the EUT, and where practical, each cable shall be terminated in a device typical of actual usage. The type(s) of interconnecting cables to be used and the interface port (of the EUT) to which these were connected;

No.	Connected cable	Length [m]	Shielded [Y/N]	Note
1	Power	1.5	No	For EUT
2	Power	1.8	No	For PC
3	USB	2.0	Yes	From EUT to PC
4	USB	1.8	Yes	From EUT to keyboard
5	USB	1.8	Yes	From EUT to mouse
6	LAN	2.0	No	From EUT to HUB
7	Headset	1.0	No	From PC to Headset
8	RGB	1.5	Yes	From PC to Monitor

9	HDMI	1.5	Yes	From PC to Monitor
10	Power	1.5	No	For Monitor

4.5 Test arrangement

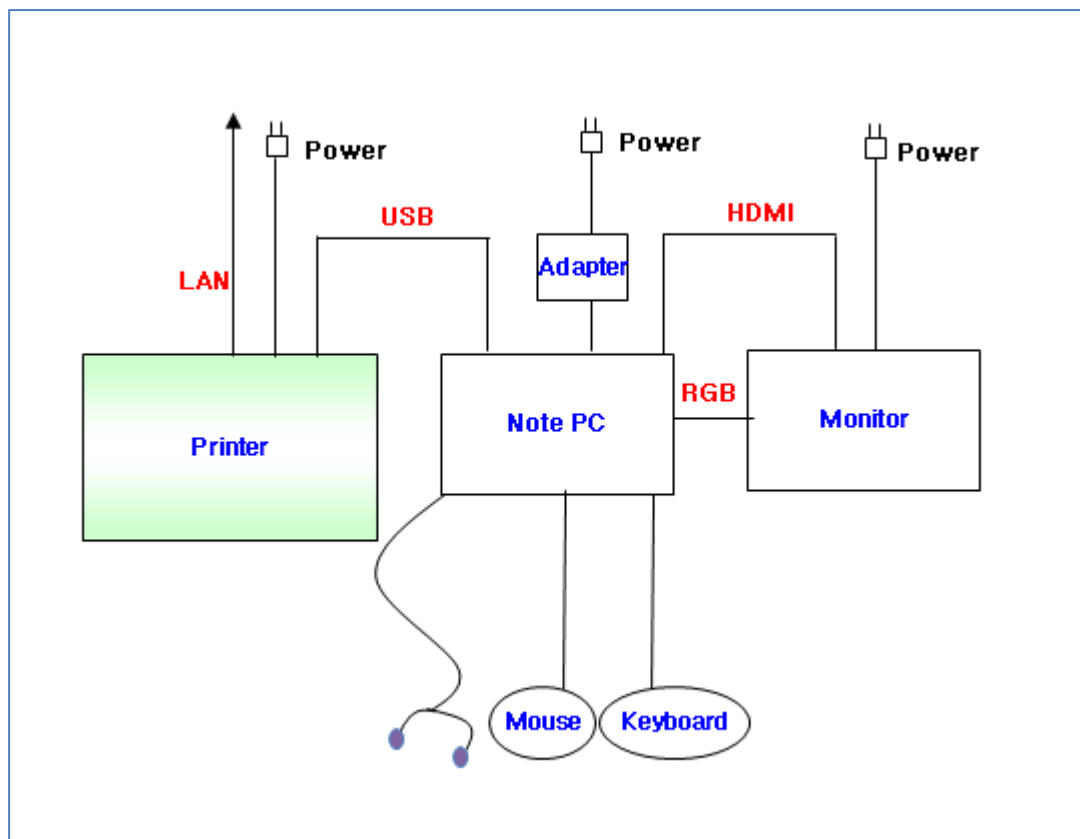

4.6 EUT Description

The following features describe EUT represented by this report:

Item	Specification and Description
Processor	Temujin C (300 MHz, ARM926EJS core)
Standard System memory	32 MB SDRAM on all configurations (Built in CPU)
Resolution	600 x 600 dpi
Paper Handling	Paper Tray(standard) 130 Sheets
Power Rating	110 VAC ~ 127 VAC, 5 A
Power Consumption	Sleep mode : 1.8 Watts Stand by mode : 60 Watts Printing simplex : 850 Watts
Printer Language	SPL-C
Interfaces	USB 2.0, Network, 802.11 b/g/n
OS compatibility	Windows 2000/XP/2003/Vista/2008/7/2008 R2 RedHat Enterprise Linux WS 4, 5 (32/64 bit) Fedora 5, 6, 7, 8, 9, 10, 11, 12, 13 (32/64 bit) SuSE Linux 10.1 (32 bit) OpenSuSE 10.2, 10.3, 11.0, 11.1, 11.2 (32/64 bit) Mandriva 2007, 2008, 2009, 2009.1, 2010 (32/64 bit) Ubuntu 6.06, 6.10, 7.04, 7.10, 8.04, 8.10, 9.04, 9.10, 10.04 (32/64 bit) SuSE Linux Enterprise Desktop 10, 11 (32/64 bit) Debian 4.0, 5.0 (32/64 bit) Mac OS X 10.4~10.7
Modes of Operation	USB Printing, Network Printing, Wireless Printing
Intended Class for Emissions	Class B

4.7 Clock Frequencies

Kind of Clocks	Frequency[MHz]	Kind of Clocks	Frequency[MHz]
CPU internal clock	300	Main source clock	12
Video clock	12	USB device clock	12
Network Clock	25	Wireless Network Clock	12.5

4.8 Test configuration and condition

The system was configured for testing in typical fashion use. Cables were attached to each of the available I/O Ports. Where applicable, peripherals were attached to the I/O cables. The mode of operation utilized for testing was selected to best simulate typical EUT use.

Power source for the EUT operating was supplied by CVCF made by the Voltech Corp.

The EUT was measured all testing with toner cartridge.

- Test Voltage : AC 120 V, 50 Hz

4.9 Measurement uncertainty

Where relevant, the following measurement uncertainty levels have been estimated for tests performed on the apparatus: (According to CISPR 16-4 and UKAS Lab 34.)

4.9.1 Emission

Test type		Measurement uncertainty (C.L. 95 %, k = 2)
Conducted disturbance	Main terminal	3.30 dB
Radiated Disturbance (30 MHz ~ 1 GHz)	Horizontal	5.27 dB
	Vertical	4.68 dB
Radiated Disturbance (1 GHz ~ 6 GHz)	Horizontal	4.76 dB
	Vertical	3.40 dB

5. Results of individual test

5.1 Conducted disturbance

Both conducted lines are measured in Quasi-Peak and Average mode, including the worst-case data points for each tested configuration. The EUT measured in accordance with the methods described in standards.

Limits for conducted disturbance at the mains ports of class B ITE

Frequency range Limits MHz	Resolution Bandwidth	Limits dB μ V	
		Quasi-peak	Average
0.15 to 0.50	9 kHz	66 to 56	56 to 46
0.50 to 5	9 kHz	56	46
5 to 30	9 kHz	60	50

NOTE 1 The lower limit shall apply at the transition frequency
 NOTE 2 The limit decreases linearly with the logarithm of the frequency in the range 0.15 MHz to 0.50 MHz.

5.1.1 Test instrumentation

Test instrumentation	Model name	Manufacturer	Serial or Firmware (No./Ver.)	Calibration	
				Date	Interval (Month)
Measuring receiver	ESU 08	R&S	100085	2012-03-23	12
Artificial mains network	ENV216	R&S	100456	2011-09-28	12
Artificial mains network	ESH3-Z5	R&S	831887/004	2011-07-27	12
Test Software	EMC32	R&S	Ver 5.20.1	-	-

5.1.2 Temperature and humidity condition

Test date	May 2, 2012	Test engineer	Sung Jin Sim		
Climate condition	Ambient temperature	22.4 °C	Relative humidity	31 %	
	Atmospheric pressure	100.2 kPa			
Test place	Shielded Room #1				

5.1.3 Photograph of Test Setup



Front



Rear

5.1.4 Test results (mains port)

- Stand-by mode

Hardware Setup: Voltage with ENV 2-Line-LISN - [EMI conducted]

Subrange 1
 Frequency Range: 150 kHz – 30 MHz
 Receiver: ESU 8
 Transducer: ENV216 / Receiver-2-Line-LISN ENV216

Scan Setup: Class B_ENV 2-Line-LISN fin [EMI conducted]

Hardware Setup: Voltage with ENV 2-Line-LISN
 Level Unit: dB μ V

Subrange	Detectors	IF Bandwidth	Meas. Time	Receiver
150 kHz – 30 MHz	Quasi Peak; Average	9 kHz	15 s	ESU 8

Test Graph

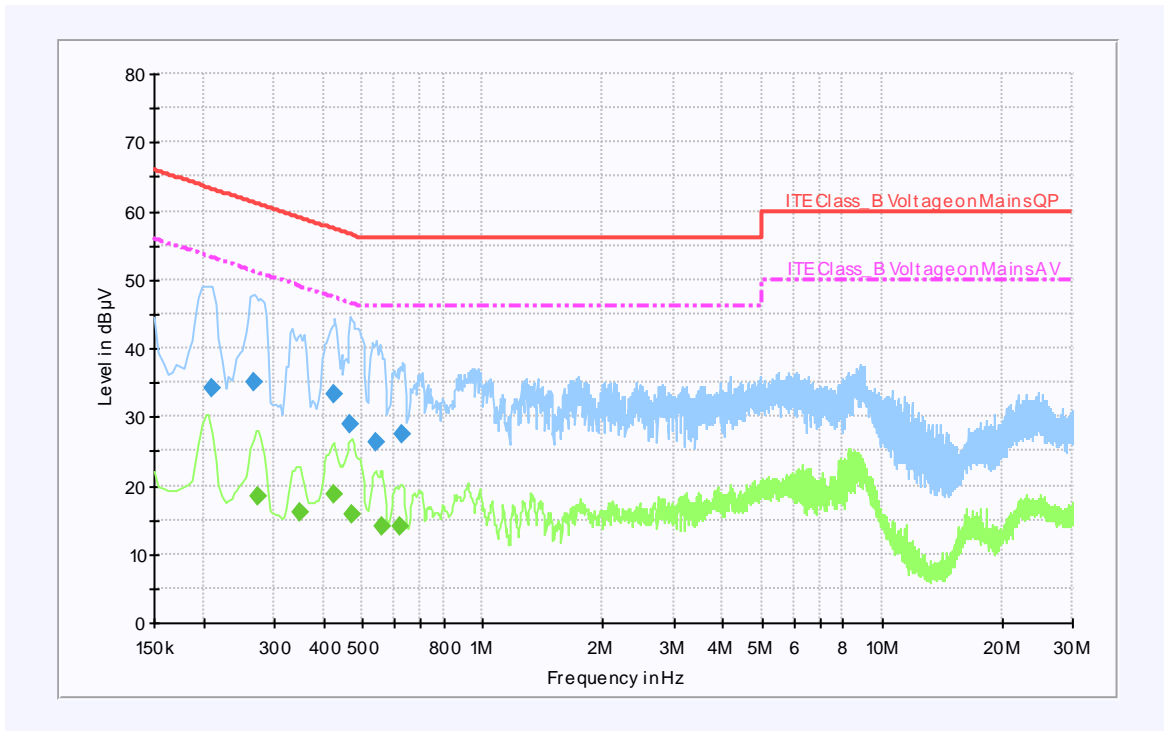

Note) Two graphs measured for both Live(L1) and Neutral(N) of the LISN are combined into one graph.

Test Results (Quasi-Peak and Average)

Quasi-peak final measurement results table

Frequency (MHz)	Quasi-Peak (dB μ V)	Line	Corr. (dB)	Margin (dB)	Limit (dB μ V)
0.210	34.2	L1	9.7	29.0	63.2
0.266	35.0	N	9.7	26.2	61.2
0.426	33.3	N	9.7	24.0	57.3
0.466	28.9	L1	9.7	27.7	56.6
0.542	26.2	N	9.7	29.8	56.0
0.630	27.4	N	9.7	28.6	56.0

Average final measurement results table

Frequency (MHz)	Average (dB μ V)	Line	Corr. (dB)	Margin (dB)	Limit (dB μ V)
0.274	18.3	N	9.7	32.7	51.0
0.350	16.1	L1	9.7	32.9	49.0
0.422	18.6	N	9.7	28.8	47.4
0.470	15.8	L1	9.7	30.7	46.5
0.558	14.0	N	9.7	32.0	46.0
0.622	14.0	N	9.7	32.0	46.0

Note) Level (Quasi-Peak and/or Average) = Meter Reading (Quasi-Peak and/or Average) + Factor (LISN Insertion Loss + Cable Loss)

Margin = Limit – Level (Quasi-Peak and/or Average)

- USB printing mode

Hardware Setup: Voltage with ENV 2-Line-LISN - [EMI conducted]

Subrange 1

Frequency Range: 150 kHz – 30 MHz
 Receiver: ESU 8
 Transducer: ENV216 / Receiver-2-Line-LISN ENV216

Scan Setup: Class B_ENV 2-Line-LISN fin [EMI conducted]

Hardware Setup: Voltage with ENV 2-Line-LISN
 Level Unit: dB μ V

Subrange	Detectors	IF Bandwidth	Meas. Time	Receiver
150 kHz – 30 MHz	Quasi Peak; Average	9 kHz	15 s	ESU 8

Test Graph

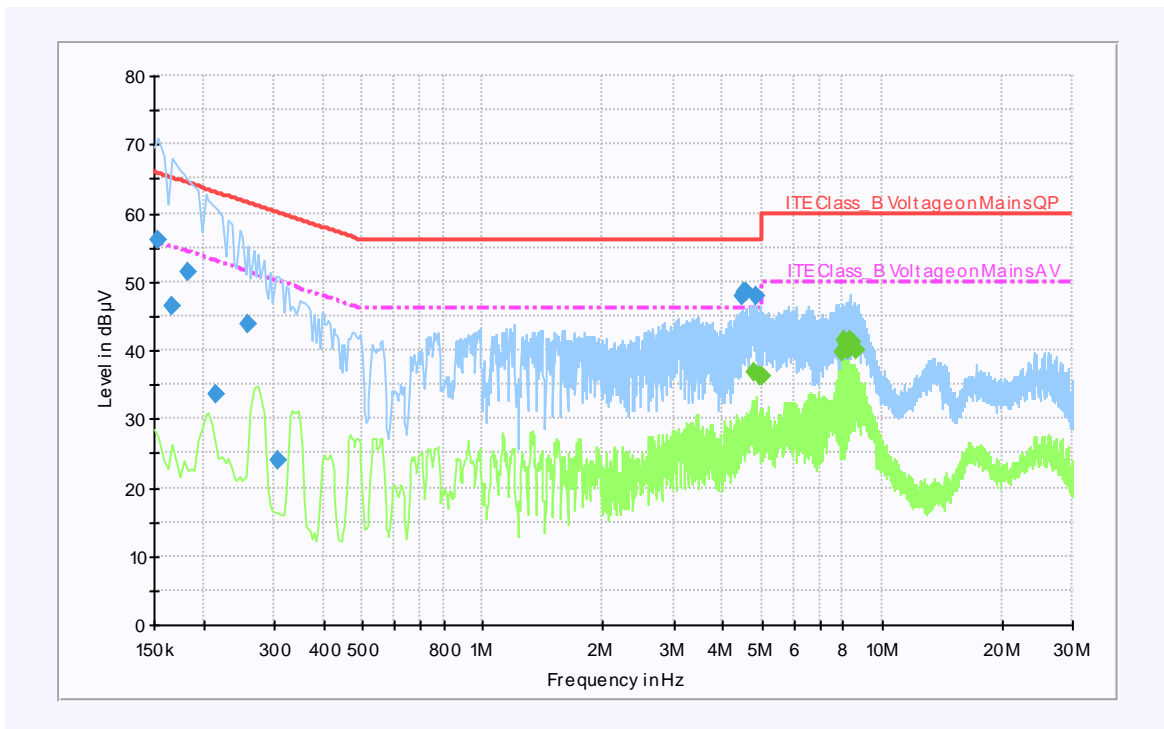

Note) Two graphs measured for both Live(L1) and Neutral(N) of the LISN are combined into one graph.

Test Results (Quasi-Peak and Average)

Quasi-peak final measurement results table

Frequency (MHz)	Quasi-Peak (dB μ V)	Line	Corr. (dB)	Margin (dB)	Limit (dB μ V)
0.154	56.0	L1	9.7	9.8	65.8
0.166	46.5	L1	9.7	18.7	65.2
0.182	51.5	L1	9.7	12.9	64.4
0.214	33.5	L1	9.7	29.5	63.0
0.258	43.8	N	9.7	17.7	61.5
0.306	24.0	N	9.7	36.1	60.1
4.492	47.9	N	9.7	8.1	56.0
4.532	48.4	N	9.7	7.6	56.0
4.592	48.3	N	9.7	7.7	56.0
4.864	47.9	N	9.7	8.1	56.0

Average final measurement results table

Frequency (MHz)	Average (dB μ V)	Line	Corr. (dB)	Margin (dB)	Limit (dB μ V)
4.796	36.8	N	9.7	9.2	46.0
4.928	36.1	N	9.7	9.9	46.0
4.996	36.2	N	9.7	9.8	46.0
7.948	39.8	N	9.8	10.2	50.0
8.088	41.5	N	9.8	8.5	50.0
8.156	40.8	N	9.8	9.2	50.0
8.228	40.0	N	9.8	10.0	50.0
8.292	41.3	N	9.8	8.7	50.0
8.436	41.1	N	9.8	8.9	50.0
8.632	39.9	N	9.8	10.1	50.0

Note) Level (Quasi-Peak and/or Average) = Meter Reading (Quasi-Peak and/or Average) + Factor (LISN Insertion Loss + Cable Loss)

Margin = Limit – Level (Quasi-Peak and/or Average)

- Network printing mode

Hardware Setup: Voltage with ENV 2-Line-LISN - [EMI conducted]

Subrange 1

Frequency Range: 150 kHz – 30 MHz
 Receiver: ESU 8
 Transducer: ENV216 / Receiver-2-Line-LISN ENV216

Scan Setup: Class B_ENV 2-Line-LISN fin [EMI conducted]

Hardware Setup: Voltage with ENV 2-Line-LISN
 Level Unit: dB μ V

Subrange	Detectors	IF Bandwidth	Meas. Time	Receiver
150 kHz – 30 MHz	Quasi Peak; Average	9 kHz	15 s	ESU 8

Test Graph

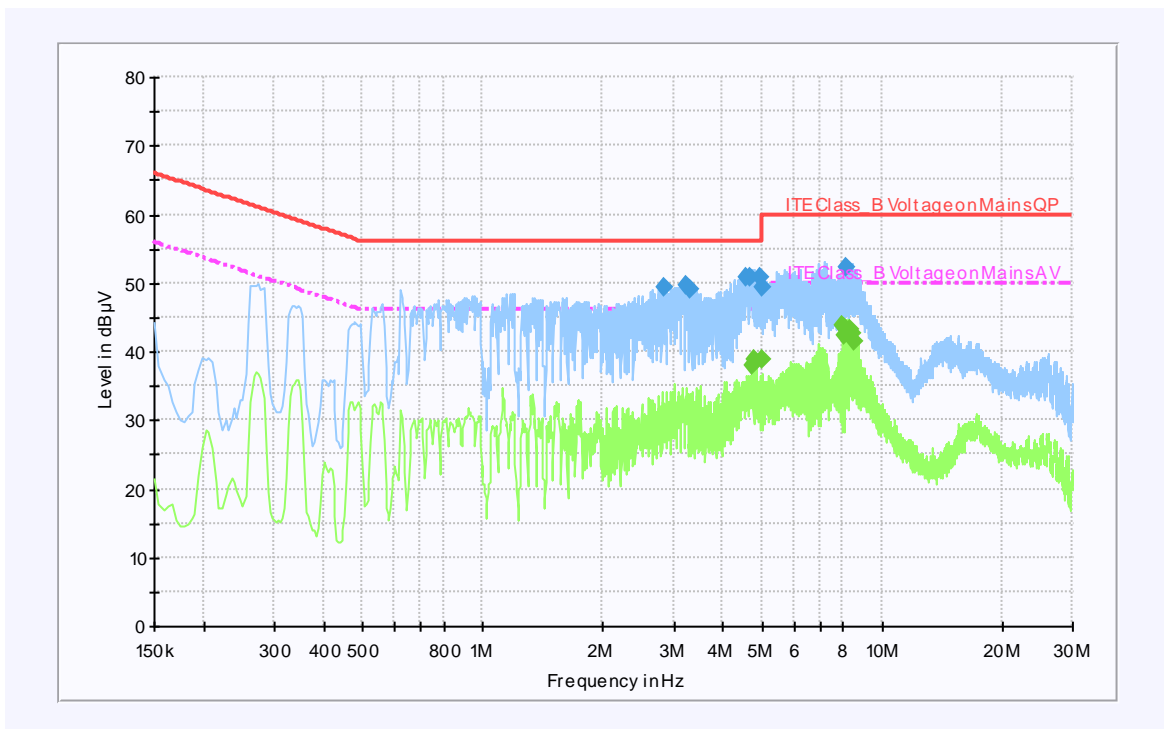

Note) Two graphs measured for both Live(L1) and Neutral(N) of the LISN are combined into one graph.

Test Results (Quasi-Peak and Average)

Quasi-peak final measurement results table

Frequency (MHz)	Quasi-Peak (dB μ V)	Line	Corr. (dB)	Margin (dB)	Limit (dB μ V)
2.832	49.2	N	9.7	6.8	56.0
3.248	49.7	N	9.7	6.4	56.0
3.304	49.2	N	9.7	6.8	56.0
4.588	50.8	N	9.7	5.2	56.0
4.656	50.8	N	9.7	5.2	56.0
4.948	50.9	N	9.7	5.1	56.0
4.992	49.3	N	9.7	6.7	56.0
8.152	52.4	L1	9.8	7.6	60.0

Average final measurement results table

Frequency (MHz)	Average (dB μ V)	Line	Corr. (dB)	Margin (dB)	Limit (dB μ V)
4.728	38.0	L1	9.7	8.0	46.0
4.796	38.8	L1	9.7	7.2	46.0
4.996	38.7	N	9.7	7.3	46.0
7.944	43.7	N	9.8	6.3	50.0
8.016	42.5	N	9.8	7.5	50.0
8.084	43.6	N	9.8	6.4	50.0
8.224	43.0	L1	9.8	7.0	50.0
8.292	43.4	L1	9.8	6.6	50.0
8.436	42.6	L1	9.8	7.4	50.0
8.488	41.5	L1	9.8	8.5	50.0

Note) Level (Quasi-Peak and/or Average) = Meter Reading (Quasi-Peak and/or Average) + Factor (LISN Insertion Loss + Cable Loss)

Margin = Limit – Level (Quasi-Peak and/or Average)

5.2 Radiated disturbance

Of those disturbances above ($L - 20\text{dB}$), where L is the limit level in logarithmic units, record at least the disturbance levels and the frequencies of the six highest disturbances.

The following data lists the significant emission frequencies, measured levels, correction factors (for antenna and cables), orientation of table, polarization and height of antenna, the corrected reading, the limit, and the amount of margin.

All measurements were taken utilizing quasi-peak detection unless stated otherwise.

Measurements were performed at an antenna to EUT distance of 10 m and elevated between 1 m and 4 m.

Both vertical and horizontal antenna polarizations were measured.

Above GHz, peak detector function mode was used with resolution bandwidth of 1 MHz and a video bandwidth of 1 MHz.

If the peak measured value complies with the average limit, it is unnecessary to perform an average measurement.

Limits for radiated disturbance of ITE at a measuring distance of 10 m

Frequency range Limits MHz	Resolution Bandwidth	Quasi-peak Limits dB μ V/m
		Class B
30 to 230	120 kHz	30
230 to 1000	120 kHz	37
NOTE 1 The lower limit shall apply at the transition frequency		
NOTE 2 Additional provisions may be required for cases where interference occurs.		

Peak measurements were made over the changeable frequency range 1 GHz to 6 GHz in accordance with internal maximum operating frequency at a measurement distance of 3 m for the following antenna and turntable arrangements:

Antenna Height (cm)	Antenna Polarisation	Turntable position (degrees)
100 ~ 400	Horizontal, Vertical	Continuous

Above 1 GHz, peak detector function mode is used with a resolution bandwidth of 1 MHz and a video bandwidth of 1 MHz.

Limits for Class B equipment at a measurement distance of 3 m

Class	Limits - dB(μ V/m)	
	Peak	Average
B	74	54
Average limit 500, $20 \log 500 = 53.979 \text{ dB} \approx 54 \text{ dB}$		

Measurements within 20 dB of the limit were then maximized by adjusting turntable position. Final measurements were made using a average detector.

Results checked manually; and points close to the limit line were re-measured.

5.2.1 Test instrumentation

Test instrumentation	Model name	Manufacturer	Serial or Firmware (No./Ver.)	Calibration	
				Date	Interval (Month)
EMI Test Receiver	ESU	R&S	100084	2011-10-10	12
EMI Test Receiver	ESCI	R&S	100370	2011-05-29	12
Bi-log Antenna	CBL6112D	SCHAFFNER	22248	2012-02-16	24
Bi-log Antenna	CBL6112D	SCHAFFNER	27627	2011-10-07	24
Amplifier	310N	SONOMA	251673	2011-12-19	12
Amplifier	310N	SONOMA	251675	2012-01-31	12
Ant. Mast	MA4000	inn-co	-	-	-
Ant. Mast	MA4000	inn-co	-	-	-
Mast Controller	CO2000	inn-co	-	-	-
RF selector	NS4900	TOYO	-	-	-
EMI Test Receiver	ESIB	R&S	832672/002	2011-11-11	12
Horn antenna	HF907	R&S	100016	2011-06-15	24
Preamplifier	SCU18	R&S	10001	2011-05-03	12
Test Software	EP5/RE	TOYO	Ver 3.10.20	-	-

5.2.2 Temperature and humidity condition

Test date	May 2~3, 2012	Test engineer	Sung Jin Sim	
Climate condition	Ambient temperature	22.6 °C	Relative humidity	30 %
	Atmospheric pressure	100.8 kPa		
Test place	10 m Semi-Anechoic Chamber			

5.2.3 Photograph of Test Setup



Front (Below 1GHz)

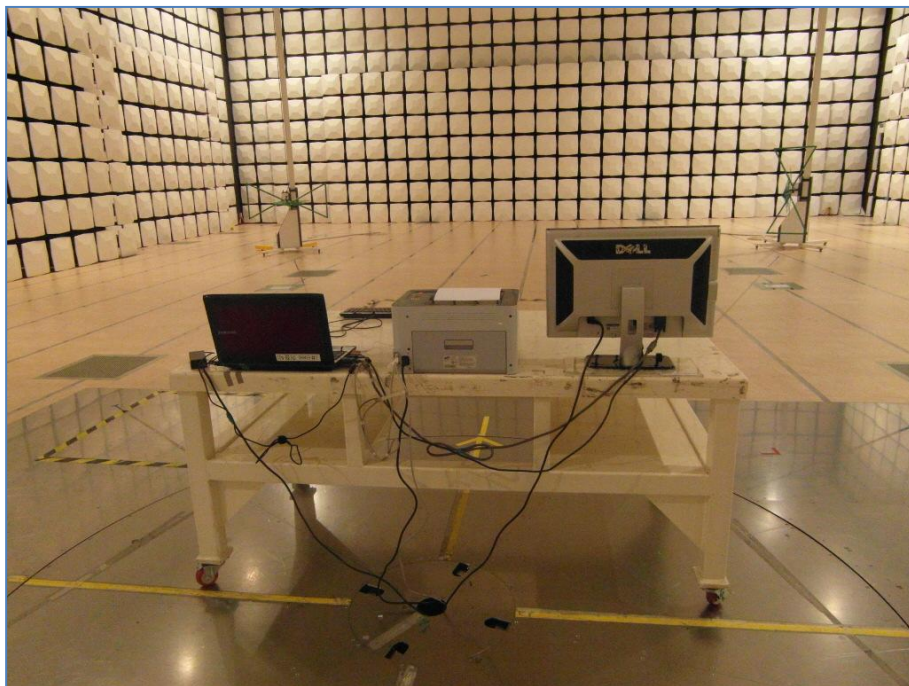

Rear (Below 1GHz)

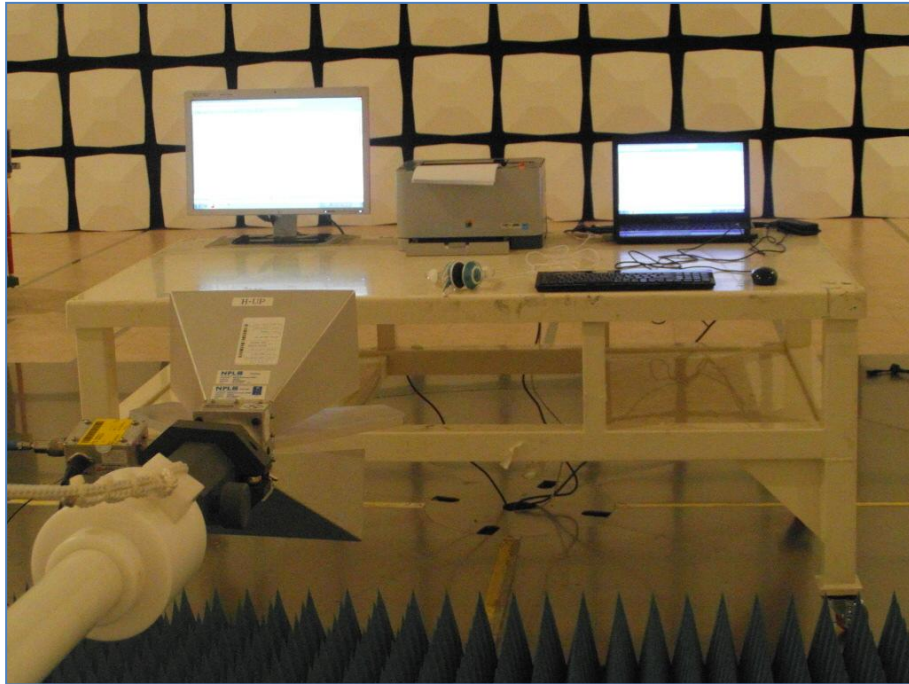

Front (above 1GHz)



Rear (above 1GHz)

5.2.4 Test results

5.2.4.1 30 MHz to 1GHz test results

- Stand-by Mode

Test Graph and Results

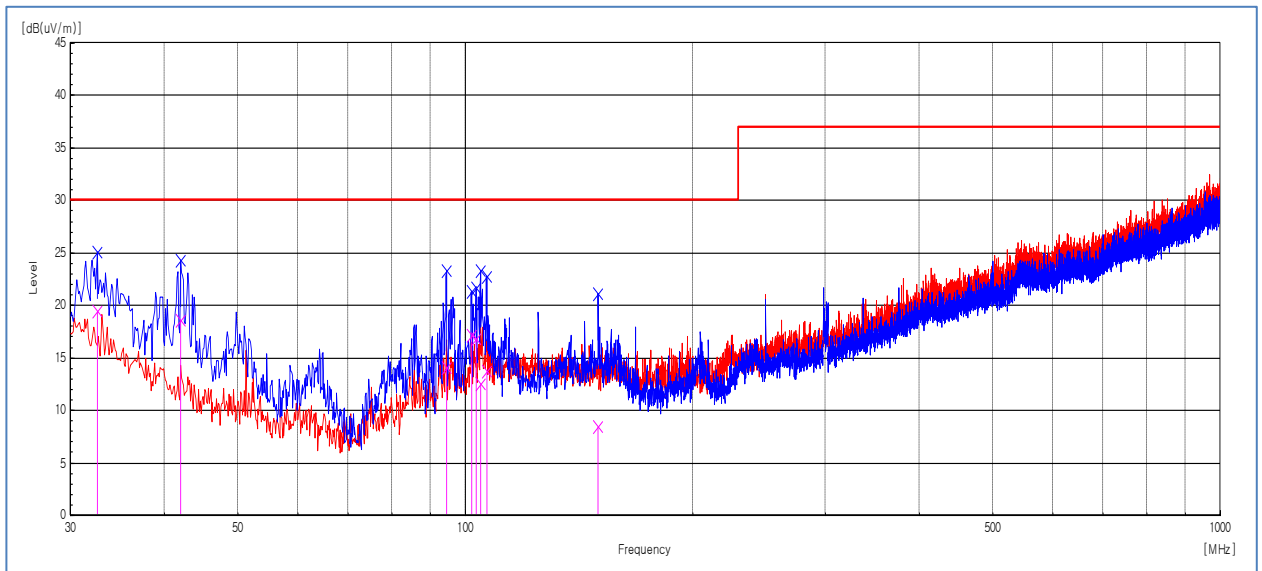

Frequency [MHz]	Pol.	Reading QP [dB(μV)]	Factor [dB(1/m)]	Level QP [dB(μV /m)]	Limit [dB(μV /m)]	Margin QP [dB]	Height [cm]	Angle [deg]
32.546	V	34.1	-14.6	19.5	30	10.5	112	347.2
42.004	V	38.1	-19.5	18.6	30	11.4	124	273.7
94.384	V	33.5	-19.4	14.1	30	15.9	164	149.5
101.901	V	35.4	-18.2	17.2	30	12.8	106	131.2
103.235	V	35	-18.2	16.8	30	13.2	100	51.8
104.69	V	30.5	-18	12.5	30	17.5	295	107.3
106.751	V	31.4	-17.7	13.7	30	16.3	216	79.5
149.916	V	26.6	-18.1	8.5	30	21.5	365	56.2

Note) Receiving antenna polarization : Horizontal and/or Vertical

Test Distance : 10 m, Antenna Height : 1 m to 4 m

Level QP (Quasi-Peak) = Reading QP + Factor (Antenna Factor + Cable Loss - Amp. Gain)

Margin QP (Quasi-Peak) = Limit – Level QP

- USB printing Mode

Test Graph and Results

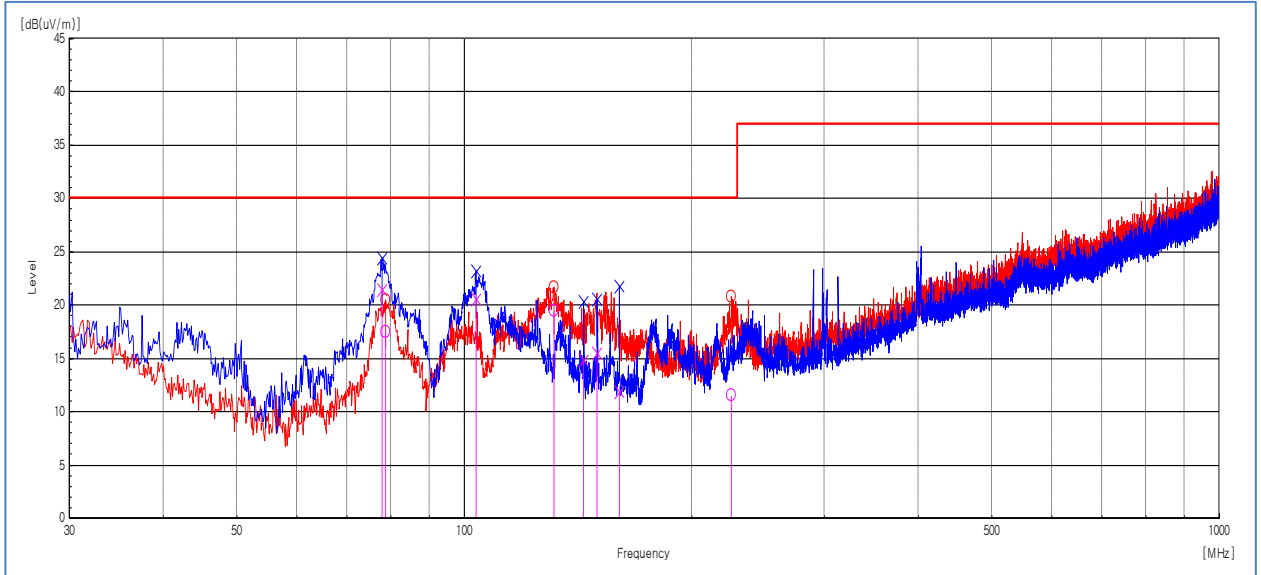

Frequency [MHz]	Pol.	Reading QP [dB(μV)]	Factor [dB(1/m)]	Level QP [dB(μV /m)]	Limit [dB(μV /m)]	Margin QP [dB]	Height [cm]	Angle [deg]
77.894	V	44.5	-23.1	21.4	30	8.6	102	271.6
78.743	H	40.1	-22.6	17.5	30	12.5	395	0.5
103.599	V	38.7	-18.1	20.6	30	9.4	113	322.5
131.365	H	36.3	-16.8	19.5	30	10.5	365	358.7
143.975	V	32.8	-18	14.8	30	15.2	116	345.3
150.038	V	33.6	-18.1	15.5	30	14.5	100	35
160.465	V	30.5	-18.6	11.9	30	18.1	102	67.4
225.94	H	29.3	-17.7	11.6	30	18.4	352	0.5

Note) Receiving antenna polarization : Horizontal and/or Vertical

Test Distance : 10 m, Antenna Height : 1 m to 4 m

Level QP (Quasi-Peak) = Reading QP + Factor (Antenna Factor + Cable Loss - Amp. Gain)

Margin QP (Quasi-Peak) = Limit – Level QP

- Network printing Mode

Test Graph and Results

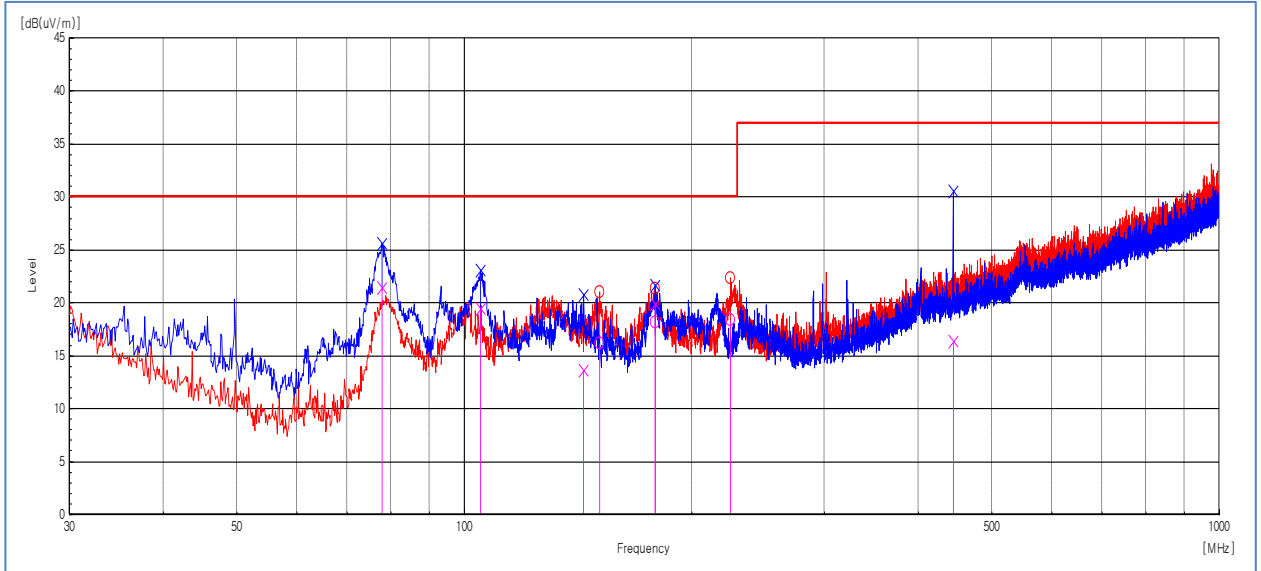

Frequency [MHz]	Pol.	Reading QP [dB(μV)]	Factor [dB(1/m)]	Level QP [dB(μV /m)]	Limit [dB(μV /m)]	Margin QP [dB]	Height [cm]	Angle [deg]
77.773	V	44.6	-23.1	21.5	30	8.5	110	272.4
443.826	V	25.7	-9.3	16.4	37	20.6	106	179.5
105.054	V	37.5	-18	19.5	30	10.5	123	0.8
225.213	H	36.3	-17.9	18.4	30	11.6	395	311.6
178.895	V	39.2	-19.3	19.9	30	10.1	103	14.2
179.138	H	37	-18.8	18.2	30	11.8	378	228.7
151.008	H	34.2	-18	16.2	30	13.8	382	311.6
143.975	V	31.6	-18	13.6	30	16.4	105	359.4

Note) Receiving antenna polarization : Horizontal and/or Vertical

Test Distance : 10 m, Antenna Height : 1 m to 4 m

Level QP (Quasi-Peak) = Reading QP + Factor (Antenna Factor + Cable Loss - Amp. Gain)

Margin QP (Quasi-Peak) = Limit – Level QP

5.2.4.2 1 GHz to 2 GHz test results

- Stand-by Mode

Test Results

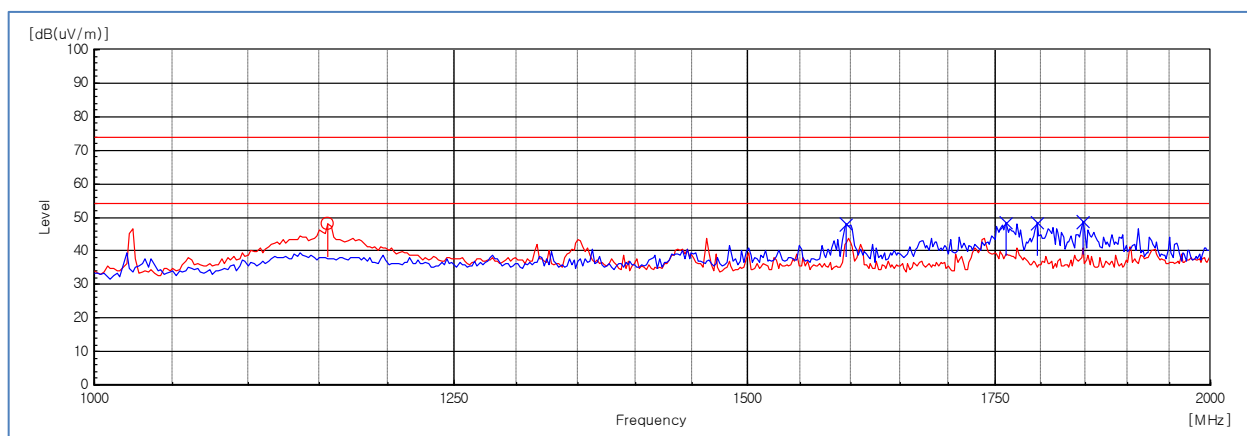

Peak Measurement

Frequency [MHz]	POL	Reading PK [dB(uV)]	Factor [dB(1/m)]	Level PK [dB(uV/m)]	Limit [dB(uV/m)]	Margin PK [dB]	Height [cm]	Angle [deg]
1156.313	H	58.3	-10.4	47.9	74	26.1	108	135.6
1595.19	V	57.2	-9.3	47.9	74	26.1	108	2.7
1761.523	V	56.7	-8.2	48.5	74	25.5	108	0.7
1795.591	V	56.4	-8	48.4	74	25.6	108	6.8
1847.695	V	56.1	-7.5	48.6	74	25.4	108	4.3

Note1) Receiving antenna polarization : Horizontal and Vertical

Level PK (Peak) = Reading PK (Peak) + Factor (Antenna Factor + Cable Loss - Amp. Gain)

Level AV (Average) = Reading AV (Average) + Factor (Antenna Factor + Cable Loss - Amp. Gain)

Margin PK (Peak) = Limit – Level PK (Peak)

Margin AV (Average) = Limit – Level AV (Average)

- USB printing Mode

Test Results

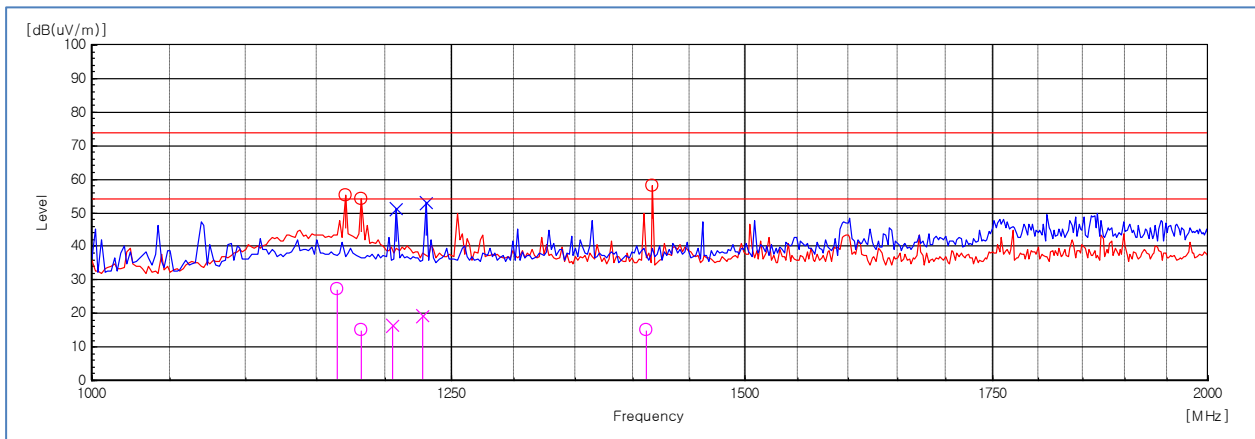

Peak Measurement

Frequency [MHz]	POL	Reading PK [dB(uV)]	Factor [dB(1/m)]	Level PK [dB(uV/m)]	Limit [dB(uV/m)]	Margin PK [dB]	Height [cm]	Angle [deg]
1170.341	H	65.8	-10.4	55.4	74	18.6	108	76.4
1182.365	H	64.5	-10.3	54.2	74	19.8	108	200.2
1208.417	V	61.4	-10.2	51.2	74	22.8	108	117.7
1230.461	V	63	-10.1	52.9	74	21.1	108	323
1416.834	H	67.6	-9.4	58.2	74	15.8	108	2.4

Average Measurement

Frequency [MHz]	POL	Reading AV [dB(uV)]	Factor [dB(1/m)]	Level AV [dB(uV/m)]	Limit [dB(uV/m)]	Margin AV [dB]	Height [cm]	Angle [deg]
1164.46	H	37.6	-10.4	27.2	54	26.8	108	60.4
1181.844	H	25.5	-10.3	15.2	54	38.8	108	199.6
1204.95	V	26.6	-10.2	16.4	54	37.6	108	118.4
1228.398	V	29.5	-10.1	19.4	54	34.6	108	322.4
1410.742	H	24.4	-9.4	15	54	39	108	2.9

Note1) Receiving antenna polarization : Horizontal and Vertical

Level PK (Peak) = Reading PK (Peak) + Factor (Antenna Factor + Cable Loss - Amp. Gain)

Level AV (Average) = Reading AV (Average) + Factor (Antenna Factor + Cable Loss - Amp. Gain)

Margin PK (Peak) = Limit – Level PK (Peak)

Margin AV (Average) = Limit – Level AV (Average)

- Network printing Mode

Test Results

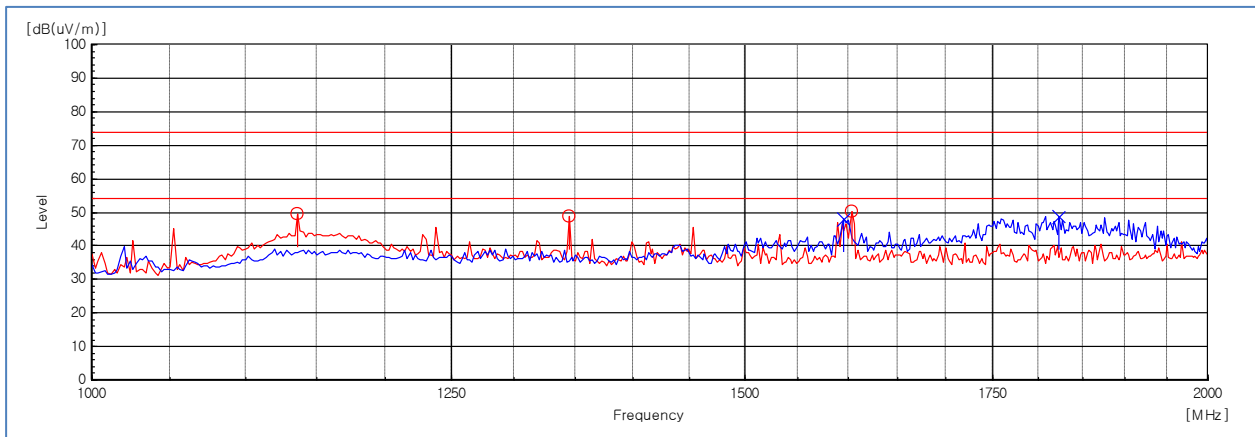

Peak Measurement

Frequency [MHz]	POL	Reading PK [dB(uV)]	Factor [dB(1/m)]	Level PK [dB(uV/m)]	Limit [dB(uV/m)]	Margin PK [dB]	Height [cm]	Angle [deg]
1136.273	H	60.1	-10.5	49.6	74	24.4	108	328.6
1344.689	H	58.3	-9.7	48.6	74	25.4	108	63.6
1595.19	V	57.2	-9.3	47.9	74	26.1	108	23.6
1603.206	H	59.5	-9.3	50.2	74	23.8	108	278
1823.647	V	56.5	-7.8	48.7	74	25.3	108	359.3

Note1) Receiving antenna polarization : Horizontal and Vertical

Level PK (Peak) = Reading PK (Peak) + Factor (Antenna Factor + Cable Loss - Amp. Gain)

Level AV (Average) = Reading AV (Average) + Factor (Antenna Factor + Cable Loss - Amp. Gain)

Margin PK (Peak) = Limit – Level PK (Peak)

Margin AV (Average) = Limit – Level AV (Average)

Appendix – EUT photography



Front View



Rear View & Label location



Left View



Right View



Top View

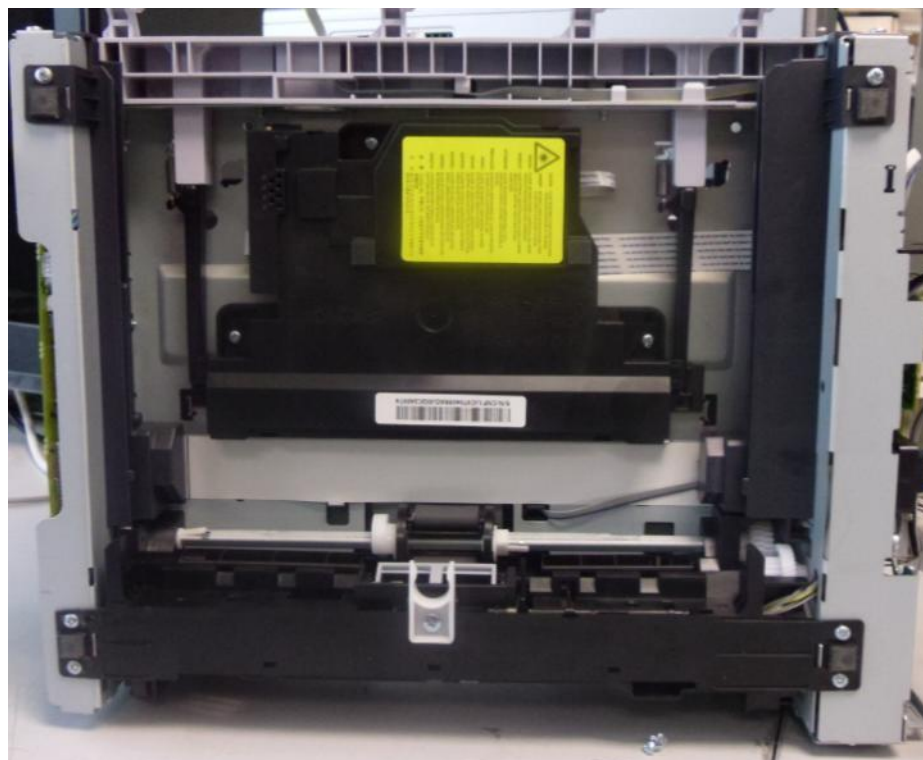

Bottom View



Inside View(Front)



Inside View(Leftside)



Inside View(Rear)

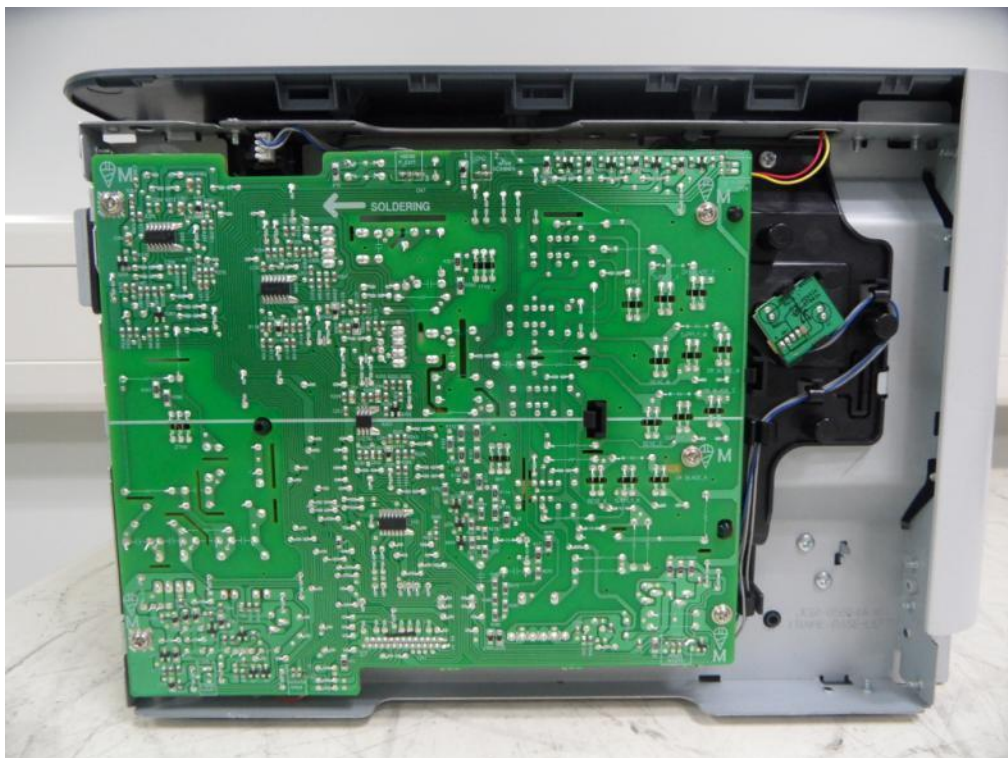

Inside View(Rightside)



Label