

# TEST REPORT

OF

FCC Part 15 Subpart B&C §15.247/RSS-210 Issue 7, RSS-Gen Issue 2

FCC ID/IC Certification: A3LBTW400/639E-BTW400

Equipment Under Test : 2CH Audio Transceiver  
Model Name : BTW400  
Serial No. : N/A  
Applicant : SAMSUNG ELECTRONICS CO.,LTD.  
Manufacturer : SAMSUNG ELECTRONICS HUIZHOU CO.,LTD.  
Date of Test(s) : 2008-01-10 ~ 2008-02-20  
Date of Issue : 2008-03-03

In the configuration tested, the EUT complied with the standards specified above.

**Tested By:**



**Date**

**2008-03-03**

**Feel Jeong**

**Approved By**



**Date**

**2008-03-03**

**Denny Ham**

*The results shown in this test report refer only to the sample(s) tested unless otherwise stated. This test report cannot be reproduced, except in full, without prior written permission of the Company.*

# INDEX

<u>TABLE OF CONTENTS</u>	Page
1. General Information -----	3
2. Transmitter AC Power Line Conducted Emission-----	6
3. Receiver AC Power Line Conducted Emission-----	11
4. Transmitter Radiated Spurious Emissions and Conducted Spurious Emission-----	15
5. Receiver Radiated Spurious Emission-----	27
6. 6 dB Bandwidth and 99 % BW-----	29
7. Maximum Peak Output Power -----	35
8. Power Spectral Density -----	38
9. Antenna Requirement -----	41
10.RF Exposure Evaluation -----	42
Appendix A-1. Photo of Spurious Emission Test	
Appendix A -2. Photos of Conducted Power Line Test	
Appendix B. Photos of the EUT	

*The results shown in this test report refer only to the sample(s) tested unless otherwise stated. This test report cannot be reproduced, except in full, without prior written permission of the Company.*

## 1. General Information

### 1.1. Testing Laboratory

SGS Testing Korea Co., Ltd.

-Wireless Div. 2FL, 18-34, Sanbon-dong, Gunpo-si, Gyeonggi-do, Korea 435-040

- 705, Dongchun-Dong Sooji-Gu, Yongin-Shi, Kyungki-Do, South Korea.

[www.electrolab.kr.sgs.com](http://www.electrolab.kr.sgs.com)

Telephone : +82 +31 428 5700

FAX : +82 +31 427 2371

### 1.2. Details of Applicant

Applicant : SAMSUNG ELECTRONICS CO.,LTD.  
 Address : 416, Maetan-dong, Yeongtong-gu, Suwon-si, Gyeonggi-do, Korea  
 Contact Person : O-Won, Seo  
 Phone No. : 82-31-227-6775  
 Fax No. : -

### 1.3. Description of EUT

<b>Kind of Product</b>	2CH Audio Transceiver
<b>Model Name</b>	BTW400
<b>Serial Number</b>	N/A
<b>Power Supply</b>	DC 5 V
<b>Frequency Range</b>	5745 ~ 5805 MHz
<b>Modulation Technique</b>	DSSS
<b>Number of Channels</b>	4
<b>Operating Conditions</b>	-20 ~ 55
<b>Antenna Type</b>	FIFA Type
<b>Antenna Gain</b>	-1.22 dBi

### 1.4. Details of modification

-N/A

*The results shown in this test report refer only to the sample(s) tested unless otherwise stated. This test report cannot be reproduced, except in full, without prior written permission of the Company.*

**1.5. Test Equipment List**

EQUIPMENT	MANUFACTURER	MODEL	CAL DUE.
Signal Generator	Agilent	E4438C	May 2008
Spectrum Analyzer	R&S	FPS40	Dec. 2008
Pre amplifier	Agilent	8449B	May 2008
High Pass Filter	Wainwright Instrument GmbH	WHK 6.0 /18.G-10SS	Dec. 2008
Attenuator	Agilent	8494B	May 2008
Two-Line V-Network	Rohde & Schwarz	ESHS10	Aug. 2008
Test Receiver	Rohde & Schwarz	ESVS10	May 2008
Test Receiver	Rohde & Schwarz	ESHS10	Aug. 2008
Ultra-Broadband Antenna	Rohde & Schwarz	HL562	Sep. 2008
Horn Antenna	Electro-Metrics	RGA-60	Jul. 2009
Horn Antenna	Schwarzbeck Mess-Elektronik	BBHA9170	May. 2008
Anechoic Chamber	SY Corporation	L W H 6.5 3.5 3.5	Aug. 2008

*The results shown in this test report refer only to the sample(s) tested unless otherwise stated. This test report cannot be reproduced, except in full, without prior written permission of the Company.*

### 1.6. Summary of Test Results

The EUT has been tested according to the following specifications:

APPLIED STANDARD:FCC Part15, RSS-210,RSS-Gen			
Section in FCC 15	Section in RSS-210 RSS-Gen	Test Item	Result
15.207	RSS-Gen 7.2.2	Transmitter AC Power Line Conducted Emission	Complied
15.107	RSS-Gen 7.2.2	Receiver AC Power Line Conducted Emission	Complied
15.205(a) 15.209 15.247(d)	A8.5	Transmitter Radiated Spurious Emissions Conducted Spurious Emission	Complied
15.109(a)	RSS-Gen 6	Receiver Radiated Spurious Emission	Complied
15.247(a)(2)	A8.2(a)	6 dB Bandwidth and 99 % BW	Complied
15.247(b)(1)	A8.4(3)	Maximum Peak Output Power	Complied
15.247(f)	A8.3(1)	Power Spectral Density	Complied
15.247(i) 1.1307(b)(1)	RSS-Gen 5.5/ RSS-102	Maximum Permissible Exposure (Exposure of Humans to RF Fields)	Complied

*The results shown in this test report refer only to the sample(s) tested unless otherwise stated. This test report cannot be reproduced, except in full, without prior written permission of the Company.*

## 2. Conducted Power Line Test

### 2.1. Test Setup

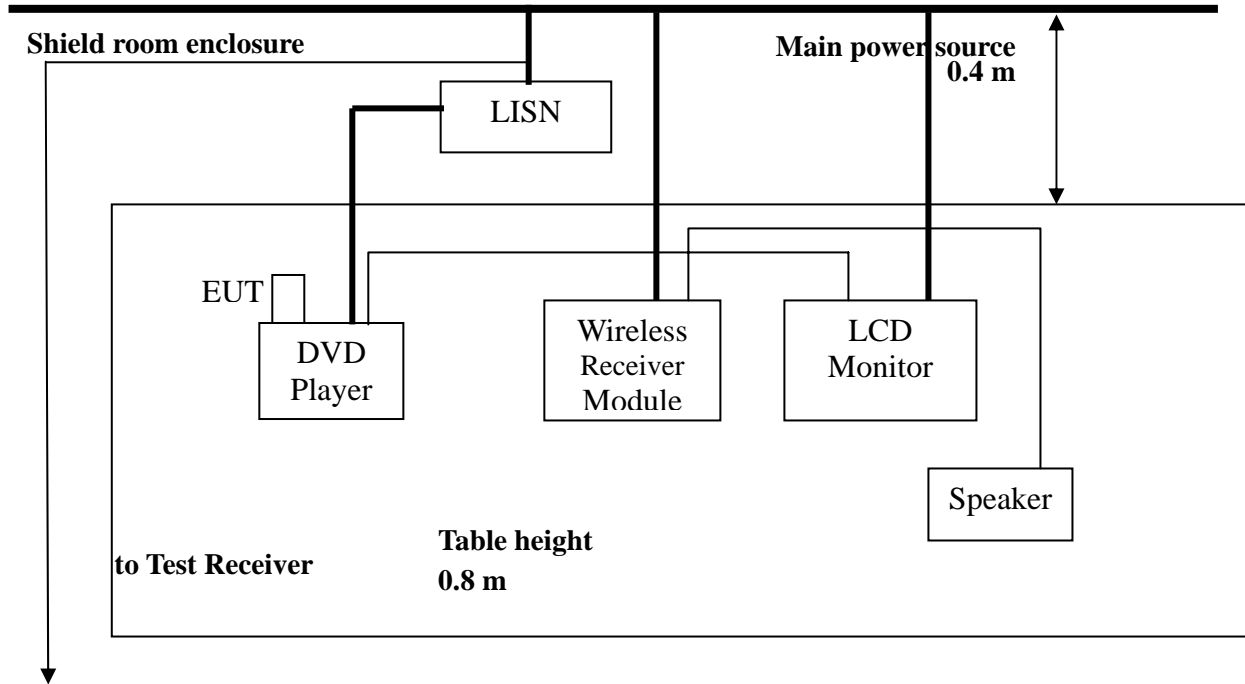

### 2.2. Limit

According to §15.207(a) for an intentional radiator that is designed to be connected to the public utility (AC) power line, the radio frequency voltage that is conducted back onto the AC power line on any frequency or frequencies, within the band 150 kHz to 30 MHz, shall not exceed the limits in the following table, as measured using a 50 uH/50 ohm line impedance stabilization network(LISN).

Compliance with the provision of this paragraph shall on the measurement of the radio frequency voltage between each power line and ground at the power terminal. The lower applies at the boundary between the frequency ranges.

Frequency of Emission (MHz)	Conducted limit (dBμV)	
	Quasi-peak	Average
0.15 – 0.50	66-56*	56-46*
0.50 – 5.00	56	46
5.00 – 30.0	60	50

\* Decreases with the logarithm of the frequency.

The results shown in this test report refer only to the sample(s) tested unless otherwise stated. This test report cannot be reproduced, except in full, without prior written permission of the Company.

### 2.3. Test Procedures

Radiated emissions from the EUT were measured according to the dictates of ANSI C63.4:2003

1. The test procedure is performed in a 6.5 m × 3.6 m × 3.6 m (L×W×H) shielded room. The EUT along with its peripherals were placed on a 1.0 m(W)× 1.5 m(L) and 0.8 m in height wooden table and the EUT was adjusted to maintain a 0.4 meter space from a vertical reference plane.
2. The EUT was connected to power mains through a line impedance stabilization network (LISN) which provides 50 ohm coupling impedance for measuring instrument and the chassis ground was bounded to the horizontal ground plane of shielded room.
3. All peripherals were connected to the second LISN and the chassis ground also bounded to the horizontal ground plane of shielded room.
4. The excess power cable between the EUT and the LISN was bundled. The power cables of peripherals were unbundled. All connecting cables of EUT and peripherals were moved to find the maximum emission.

---

*The results shown in this test report refer only to the sample(s) tested unless otherwise stated. This test report cannot be reproduced, except in full, without prior written permission of the Company.*

## 2.4. Test Results

The following table shows the highest levels of conducted emissions on both phase of Hot and Neutral line.

Ambient temperature : 23                      Relative humidity : 50 %

Frequency range : 0.15 MHz – 30 MHz

Measured Bandwidth : 9 kHz

FREQ. (MHz)	LEVEL(dBuV)		LINE	LIMIT(dBuV)		MARGIN(dB)	
	Q-Peak	Average		Q-Peak	Average	Q-Peak	Average
0.15	44.40	19.80	N	66.00	56.00	21.60	36.20
0.24	47.90	47.00	N	62.24	52.24	14.34	5.24
0.35	37.70	37.20	N	58.99	48.99	21.29	11.79
0.47	40.00	39.70	N	56.00	46.00	16.00	6.30
0.58	36.30	35.50	N	56.00	46.00	19.70	10.50
0.94	33.70	31.30	N	56.00	46.00	22.30	14.70
0.15	44.30	20.00	H	66.00	56.00	21.70	36.00
0.24	46.60	45.80	H	62.24	52.24	15.64	6.44
0.35	39.50	38.00	H	56.00	46.00	16.50	8.00
0.47	38.70	38.30	H	56.00	46.00	17.30	7.70
1.17	35.10	31.60	H	56.00	46.00	20.90	14.40
3.06	33.30	22.60	H	56.00	46.00	22.70	23.40

Note ;

Line ( H ) : Hot

Line ( N ) : Neutral

*The results shown in this test report refer only to the sample(s) tested unless otherwise stated. This test report cannot be reproduced, except in full, without prior written permission of the Company.*

**Plot of Conducted Power line**

Test mode : (Hot)

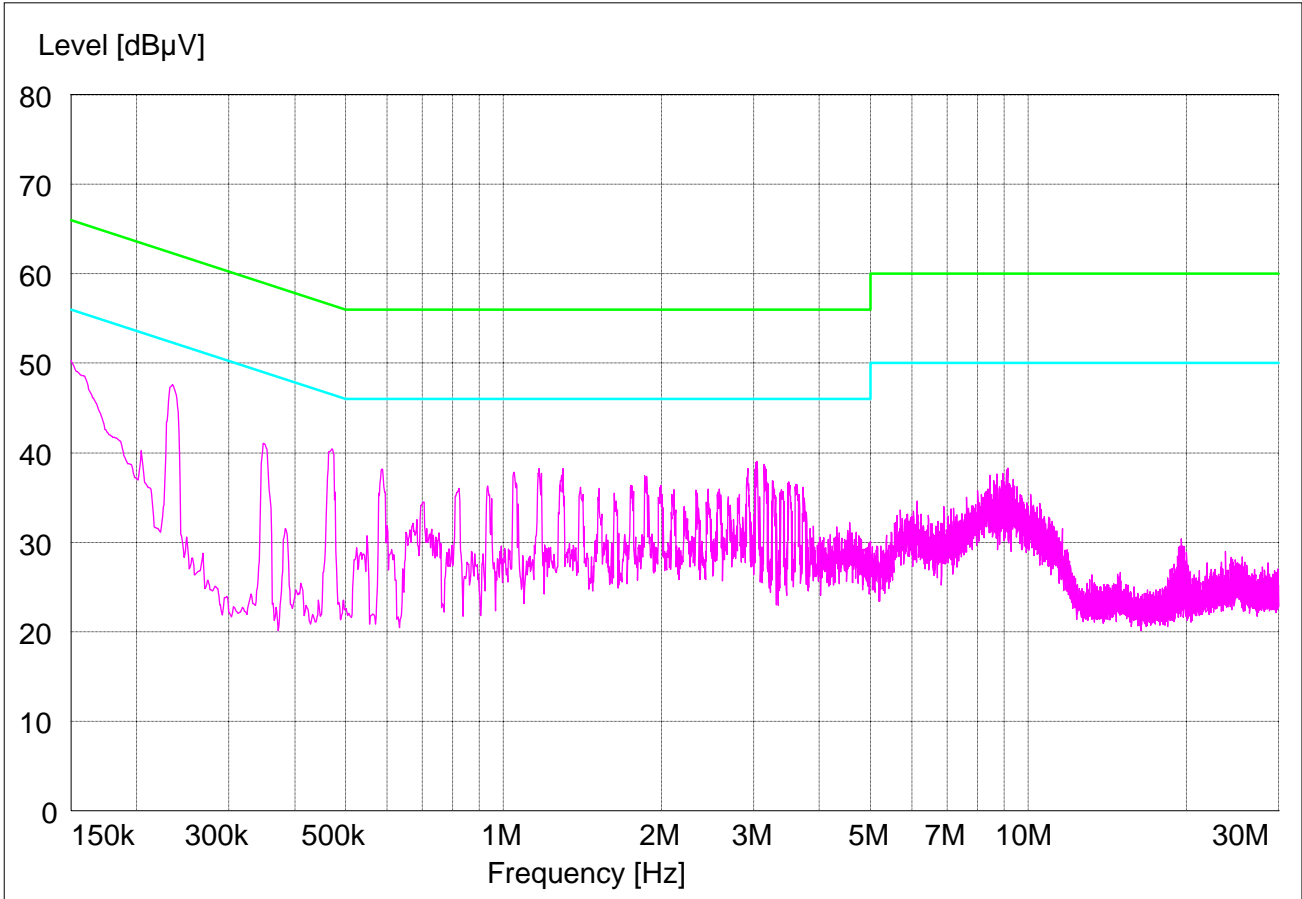

The results shown in this test report refer only to the sample(s) tested unless otherwise stated. This test report cannot be reproduced, except in full, without prior written permission of the Company.

Test mode : (Neutral)

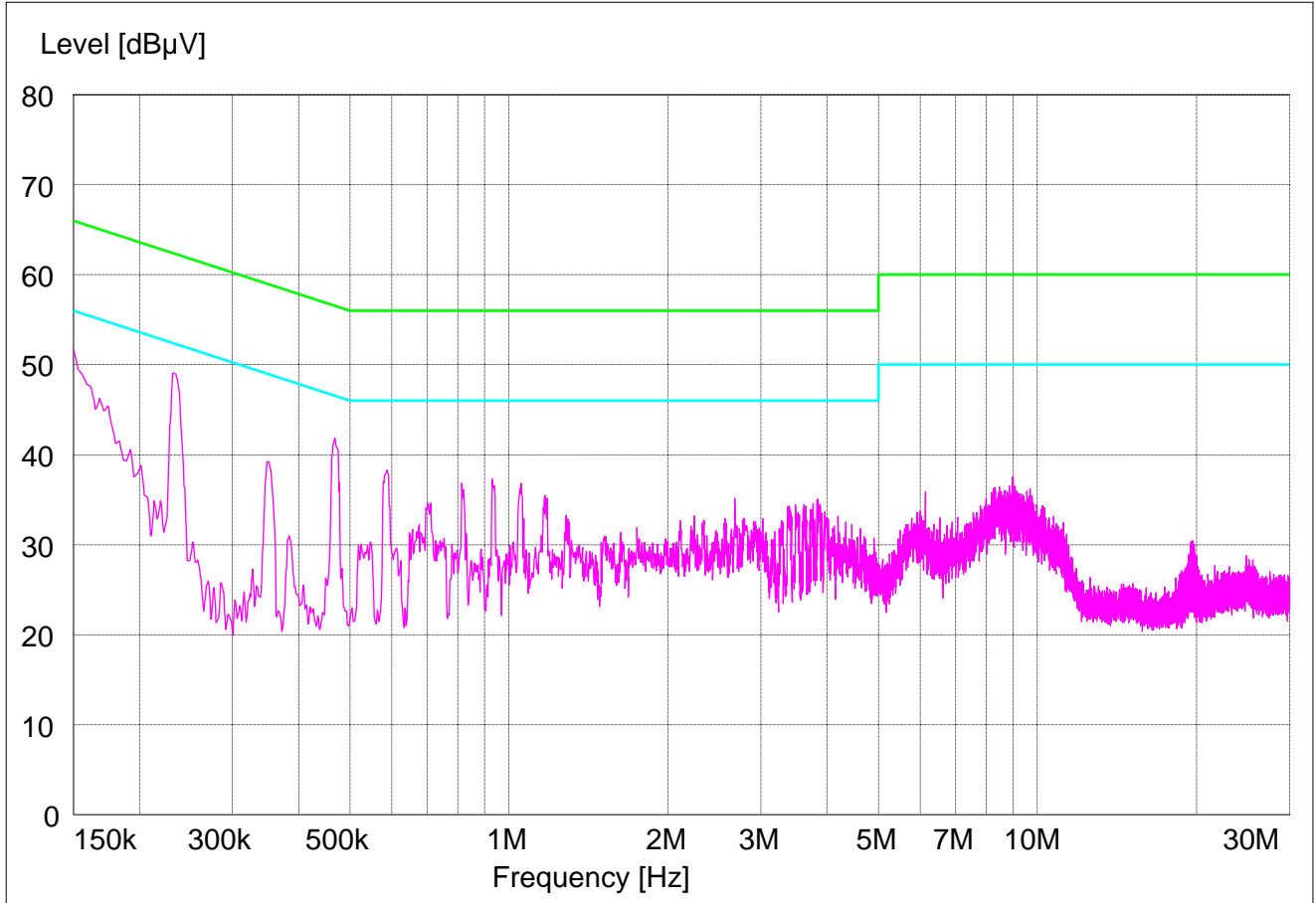

The results shown in this test report refer only to the sample(s) tested unless otherwise stated. This test report cannot be reproduced, except in full, without prior written permission of the Company.

### 3. Receiver AC Power Line Conducted Emission

#### 3.1. Test Setup- Same as clause 2.1.

#### 3.2. Limit

According to §15.107(a) Except for Class A digital devices, for equipment that is designed to be connected to the public utility (AC) power line, the radio frequency voltage that is conducted back onto the AC power line on any frequency or frequencies within the band 150 kHz to 30 MHz shall not exceed the limits in the following table, as measured using a 50  $\mu$ H/50 ohms line impedance stabilization network (LISN). Compliance with the provisions of this paragraph shall be based on the measurement of the radio frequency voltage between each power line and ground at the power terminal. The lower limit applies at the band edges.

Frequency of Emission (MHz)	Conducted limit (dB $\mu$ V)	
	Quasi-peak	Average
0.15 – 0.50	66-56*	56-46*
0.50 – 5.00	56	46
5.00 – 30.0	60	50

\* Decreases with the logarithm of the frequency.

*The results shown in this test report refer only to the sample(s) tested unless otherwise stated. This test report cannot be reproduced, except in full, without prior written permission of the Company.*

**3.3. Test Procedures- Same as clause 2.3.**

**3.4. Test Results (Worst case)**

The following table shows the highest levels of conducted emissions on both phase of Hot and Neutral line; Addition,

Ambient temperature : 22 Relative humidity : 43 %

Frequency range : 0.15 MHz – 30 MHz

Measured Bandwidth : 9 kHz

FREQ. (MHz)	LEVEL(dBuV)		LINE	LIMIT(dBuV)		MARGIN(dB)	
	Q-Peak	Average		Q-Peak	Average	Q-Peak	Average
0.15	47.40	21.30	N	66.00	56.00	18.60	34.70
0.25	49.00	48.80	N	61.69	51.69	12.69	2.89
0.38	43.00	43.10	N	58.32	48.32	15.32	5.22
0.51	41.10	41.00	N	56.00	46.00	14.90	5.00
0.63	40.80	40.80	N	56.00	46.00	15.20	5.20
0.76	40.40	39.70	N	56.00	46.00	15.60	6.30
0.15	47.40	21.20	H	66.00	56.00	18.60	34.80
0.25	47.80	47.80	H	61.69	51.69	13.89	3.89
0.38	43.10	39.00	H	56.00	46.00	12.90	7.00
0.50	42.40	42.50	H	56.00	46.00	13.60	3.50
0.76	41.80	41.80	H	56.00	46.00	14.20	4.20
0.88	41.20	40.90	H	56.00	46.00	14.80	5.10

Note ;

Line ( H ) : Hot

Line ( N ) : Neutral

*The results shown in this test report refer only to the sample(s) tested unless otherwise stated. This test report cannot be reproduced, except in full, without prior written permission of the Company.*

## Plot of Conducted Power line

Test mode : (Hot)

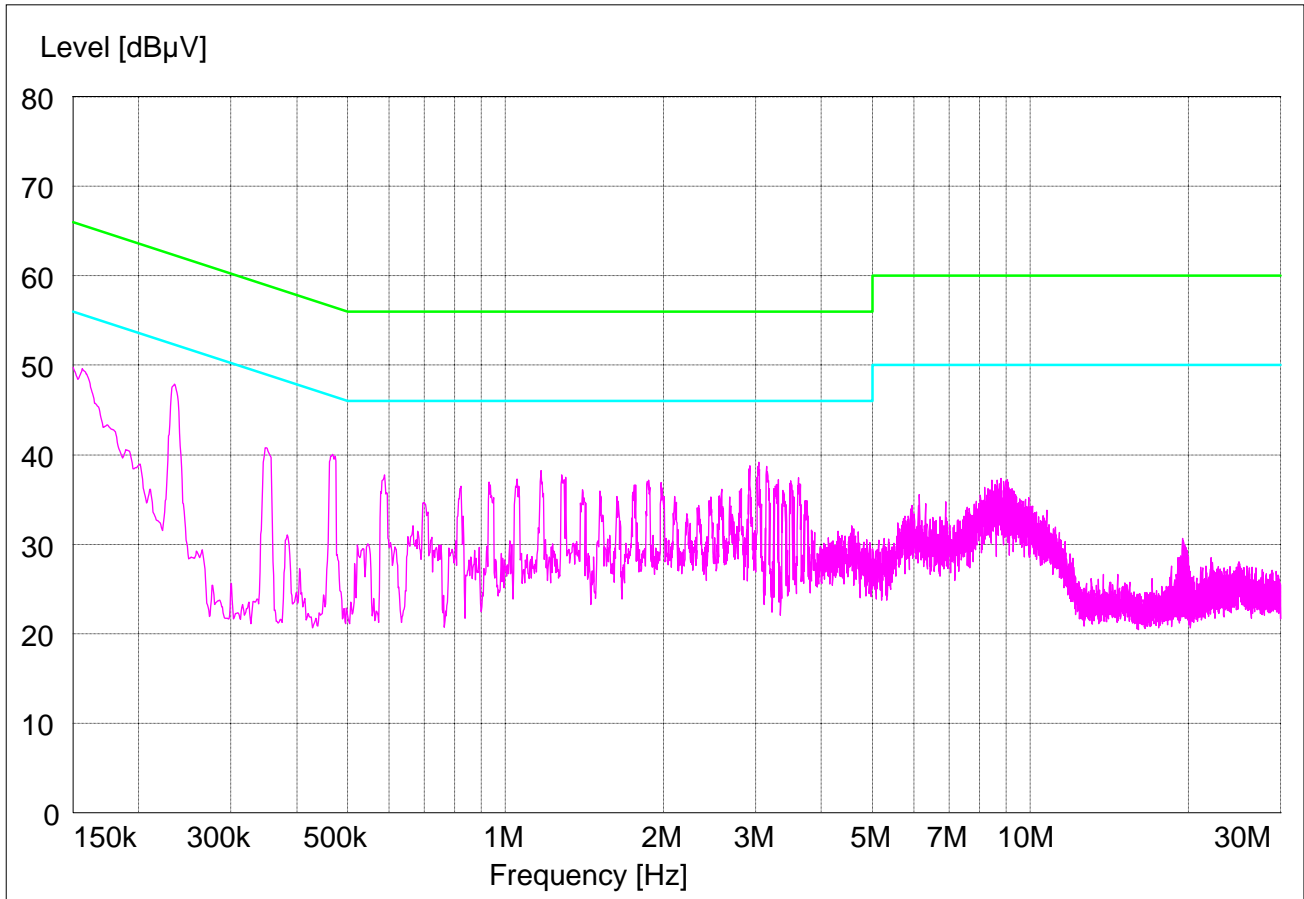

*The results shown in this test report refer only to the sample(s) tested unless otherwise stated. This test report cannot be reproduced, except in full, without prior written permission of the Company.*

Test mode : (Neutral)

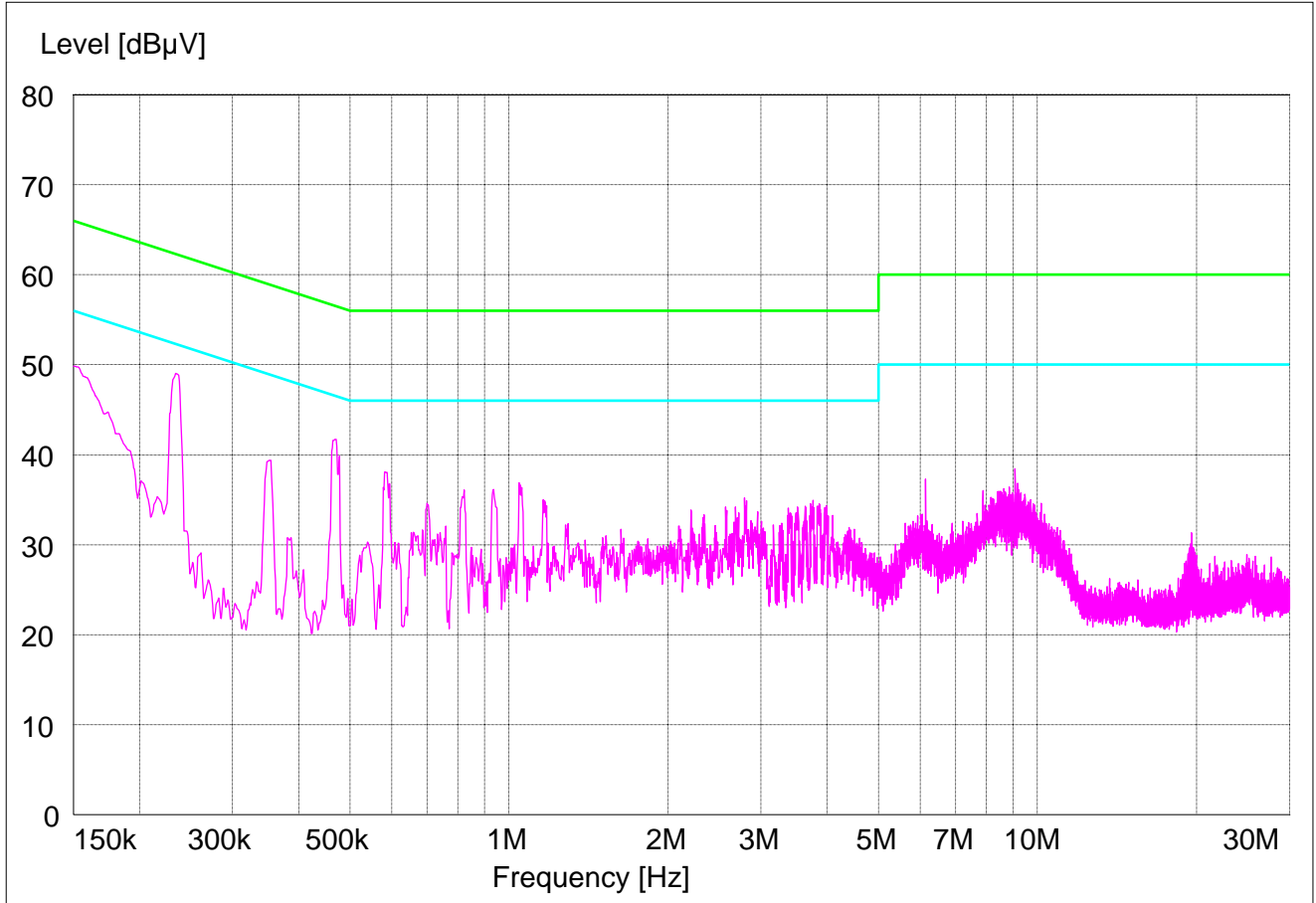

The results shown in this test report refer only to the sample(s) tested unless otherwise stated. This test report cannot be reproduced, except in full, without prior written permission of the Company.

## 4. Transmitter Radiated Spurious Emissions and Conducted Spurious Emission

### 4.1. Test Setup

#### 4.1.1. Transmitter Radiated Spurious Emissions

The diagram below shows the test setup that is utilized to make the measurements for emission from 30 MHz to 1 GHz Emissions.

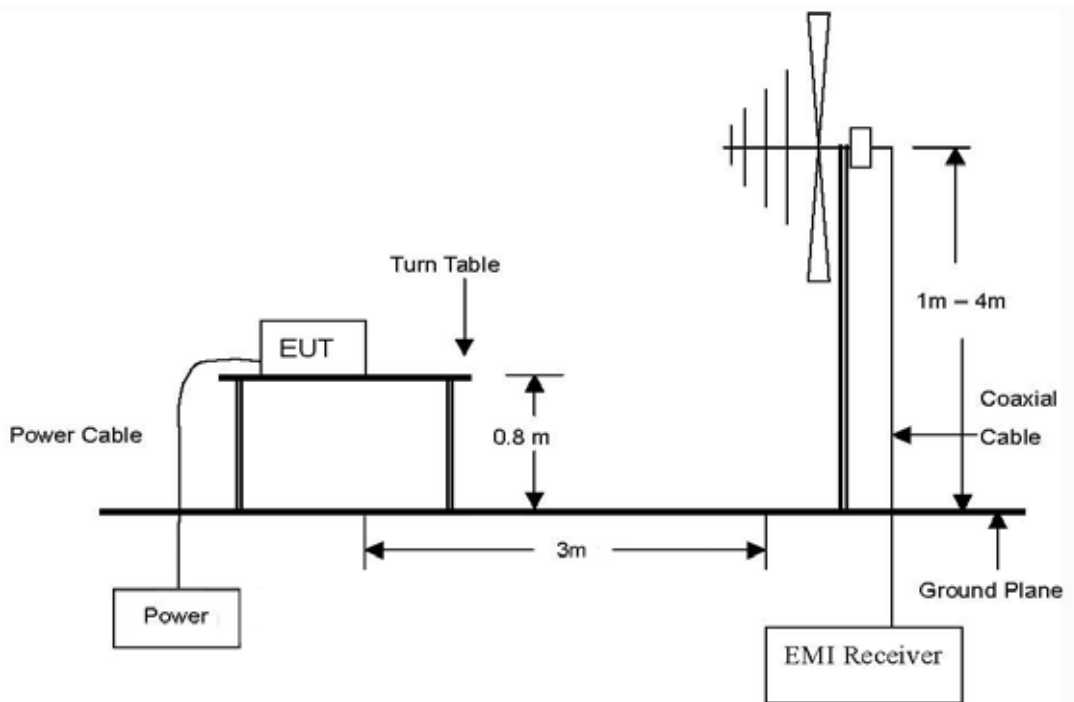

The diagram below shows the test setup that is utilized to make the measurements for emission from 1 GHz to 24 GHz Emissions.

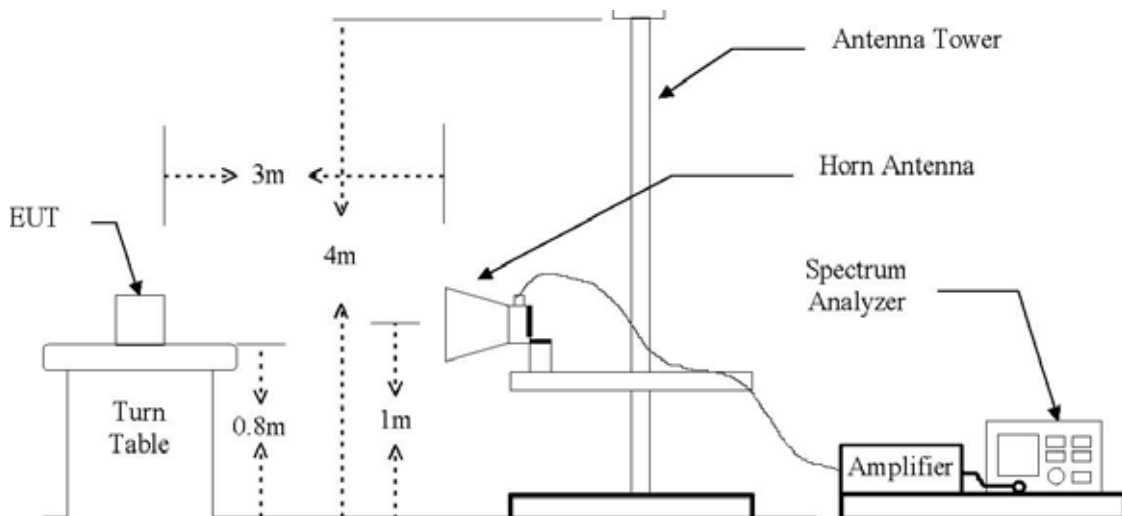

The results shown in this test report refer only to the sample(s) tested unless otherwise stated. This test report cannot be reproduced, except in full, without prior written permission of the Company.

#### 4.1.2. Conducted Spurious Emissions



#### 4.2. Limit

According to §15.247(d), in any 100 kHz bandwidth outside the frequency band in which the spread spectrum or digitally modulated intentional radiator is operating, the radio frequency power that is produced by the intentional radiator shall be at least 20 dB below that in the 100 kHz bandwidth within the band that contains the highest level of the desired power, based on either an RF conducted or a radiated measurement , provided the transmitter demonstrates compliance with the peak conducted power limits. If the transmitter complies with the conducted power limits based on the use of RMS averaging over a time interval , as permitted under paragraph(b)(3) of this section , the attenuation required under this paragraph shall be 30 dB instead of 20 dB. Attenuation below the general limits specified in section §15.209(a) is not required. In addition, radiated emission which in the restricted band, as define in section §15.205(a), must also comply the radiated emission limits specified in section §15.209(a) (see section §15.205(c))

According to § 15.109(a), for an intentional radiator devices, the general required of field strength of radiated emissions from unintentional radiators at a distance of 3 meters shall not exceed the following values :

Frequency (MHz)	Distance (Meters)	Radiated (dBμV/m)	Radiated (μV/m)
30 - 88	3	40.0	100
88 – 216	3	43.5	150
216 – 960	3	46.0	200
Above 960	3	54.0	500

According to §15.109(a), for an unintentional device, except for Class A digital devices, the field strength of radiated emission from unintentional radiators at a distance of 3 meters shall not exceed the above table.

*The results shown in this test report refer only to the sample(s) tested unless otherwise stated. This test report cannot be reproduced, except in full, without prior written permission of the Company.*

### 4.3. Test Procedures

Radiated emissions from the EUT were measured according to the dictates of ANSI C63.4:2003

#### 4.3.1. Test Procedures for Radiated Spurious Emissions

1. The EUT was placed on the top of a rotating table 0.8 meters above the ground at a 3 meter anechoic chamber test site. The table was rotated 360 degrees to determine the position of the highest radiation.
2. During performing radiated emission below 1 GHz, the EUT was set 3 meters away from the interference receiving antenna, which was mounted on the top of a variable-height antenna tower. During performing radiated emission above 1 GHz, the EUT was set 3 meter away from the interference-receiving antenna.
3. The antenna is a broadband antenna, and its height is varied from one meter to four meters above the ground to determine the maximum value of the field strength. Both horizontal and vertical polarizations of the antenna are set to make the measurement.
4. For each suspected emission, the EUT was arranged to its worst case and then the antenna was tuned to heights from 1 meter to 4 meters and the table was turned from 0 degrees to 360 degrees to find the maximum reading.
5. The test-receiver system was set to Peak Detect Function and Specified Bandwidth with Maximum Hold Mode.
6. If the emission level of the EUT in peak mode was 10 dB lower than the limit specified, then testing could be stopped and the peak values of the EUT would be reported. Otherwise the emissions that did not have 10 dB margin would be re-tested one by one using peak, quasi-peak or average method as specified and then reported in a data sheet.

#### NOTE ;

1. The resolution bandwidth and video bandwidth of test receiver/spectrum analyzer is 120 kHz for Peak detection (PK) and Quasi-peak detection (QP) at frequency below 1 GHz.
2. The resolution bandwidth and video bandwidth of test receiver/spectrum analyzer is 1MHz for Peak detection and frequency above 1 GHz.
3. The resolution bandwidth of test receiver/spectrum analyzer is 1 MHz and the video bandwidth is 10 Hz for Average detection (AV) at frequency above 1 GHz.

#### 4.3.2. Test Procedures for Conducted Spurious Emissions

1. The transmitter output was connected to the spectrum analyzer through an attenuator.
2. The bandwidth of the fundamental frequency was measured with the spectrum analyzer using RBW=100 kHz, VBW=100 kHz.

---

*The results shown in this test report refer only to the sample(s) tested unless otherwise stated. This test report cannot be reproduced, except in full, without prior written permission of the Company.*

#### 4.4. Test Results

Ambient temperature : 21 Relative humidity : 43 %

##### 4.4.1. Spurious Radiated Emission ( Worst case mode)

The frequency spectrum from 30 MHz to 1000 MHz was investigated. All emissions are not reported much lower than the prescribed limits. All reading values are quasi-peak values.

Radiated Emissions			Ant	Correction Factors		Total	FCC Limit	
Frequency (MHz)	Reading (dBuV)	Detect Mode	Pol.	AF (dB/m)	CL (dB)	Actual (dBuV/m)	Limit (dBuV/m)	Margin (dB)
39.700	16.43	Q.P.	V	14.16	0.81	31.40	40.00	8.60
299.175	25.46	Q.P.	V	10.97	2.27	38.70	46.00	7.30
447.100	18.15	Q.P.	V	15.38	2.85	36.38	46.00	9.62
595.025	14.00	Q.P.	V	16.83	3.22	34.05	46.00	11.95
740.525	12.27	Q.P.	V	18.81	3.62	34.70	46.00	11.30
888.450	13.02	Q.P.	V	20.46	4.02	37.50	46.00	8.50
Above 890.000	Not Detected	-	-	-	-	-	-	-

#### Remark:

1. All spurious emission at channels are almost the same below 1 GHz, so that the channel was chosen at representative in final test.
2. “\*” means the restricted band.
3. Actual = Reading + AF + CL

*The results shown in this test report refer only to the sample(s) tested unless otherwise stated. This test report cannot be reproduced, except in full, without prior written permission of the Company.*

#### 4.4.2. Spurious Radiated Emission (Above 1000 MHz)

The frequency spectrum above 1000 MHz was investigated. All emissions are not reported much lower than the prescribed limits. Reading values are both peak and average values.

##### A. Low Channel (5745 MHz)

Radiated Emissions			Ant	Correction Factors			Total	FCC Limit	
Frequency (MHz)	Reading (dBuV)	Detect Mode	Pol.	AF (dB/m)	CL (dB)	Amp Gain (dB)	Actual (dBuV/m)	Limit (dBuV/m)	Margin (dB)
5745.00	70.91	Peak	H	33.95	2.94	0.00	107.80	-	-
5745.00	44.43	Average	H	33.95	2.94	0.00	81.32	-	-
11490.00	59.48	Peak	H	39.76	5.54	36.21	68.57	74.00	5.43
11490.00	40.25	Average	H	39.76	5.54	36.21	49.34	54.00	4.66
17235.00	49.78	Peak	H	26.80	8.68	35.48	64.97	81.92	16.95
17235.00	35.80	Average	H	26.80	8.68	35.48	50.99	55.44	4.45
Above 17300.00	Not Detected	-	-	-	-	-	-	-	-

##### B. Middle Channel (5785 MHz)

Radiated Emissions			Ant	Correction Factors			Total	FCC Limit	
Frequency (MHz)	Reading (dBuV)	Detect Mode	Pol.	AF (dB/m)	CL (dB)	Amp Gain (dB)	Actual (dBuV/m)	Limit (dBuV/m)	Margin (dB)
5785.00	69.27	Peak	H	34.00	2.80	0.00	106.07	-	-
5785.00	46.95	Average	H	34.00	2.80	0.00	83.75	-	-
11570.00	54.67	Peak	H	39.76	6.86	36.21	65.08	74.00	8.92
11570.00	38.49	Average	H	39.76	6.86	36.21	48.90	54.00	5.10
17355.00	48.59	Peak	H	41.99	9.33	35.48	64.43	86.07	21.64
17355.00	34.13	Average	H	41.99	9.33	35.48	49.97	63.75	13.78
Above 17400.00	Not Detected	-	-	-	-	-	-	-	-

The results shown in this test report refer only to the sample(s) tested unless otherwise stated. This test report cannot be reproduced, except in full, without prior written permission of the Company.

C. High Channel (5805 MHz)

Radiated Emissions			Ant	Correction Factors			Total	FCC Limit	
Frequency (MHz)	Reading (dBuV)	Detect Mode	Pol.	AF (dB/m)	CL (dB)	Amp Gain (dB)	Actual (dBuV/m)	Limit (dBuV/m)	Margin (dB)
5805.00	69.86	Peak	H	34.04	2.86	0.00	106.76	-	-
5805.00	47.76	Average	H	34.04	2.86	0.00	84.66	-	-
11610.00	57.52	Peak	H	39.76	6.71	36.21	67.78	74.00	6.22
11610.00	40.41	Average	H	39.76	6.71	36.21	50.67	54.00	3.33
17415.00	50.52	Peak	H	41.99	8.71	35.48	65.74	86.76	21.02
17415.00	37.70	Average	H	41.99	8.71	35.48	52.92	64.66	11.74
Above 17500.00	Not Detected	-	-	-	-	-	-	-	-

**Remark:**

1. “\*” means the restricted band.
2. Measuring frequencies from 1 GHz to the 10<sup>th</sup> harmonic of highest fundamental Frequency.
3. Radiated emissions measured in frequency above 1000 MHz were made with an instrument using peak/average detector mode.
4. Average test would be performed if the peak result were greater than the average limit.
5. Actual = Reading + AF – Amp Gain + CL

The results shown in this test report refer only to the sample(s) tested unless otherwise stated. This test report cannot be reproduced, except in full, without prior written permission of the Company.

### 4.4.3. Spurious RF Conducted Emissions: Plot of Spurious RF Conducted Emission

Low Channel

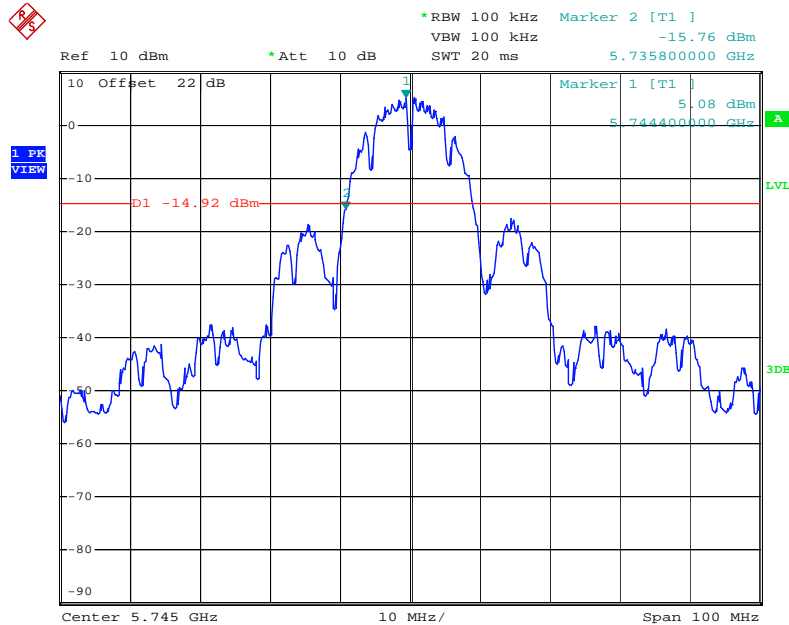

Date: 14.JAN.2008 23:59:33

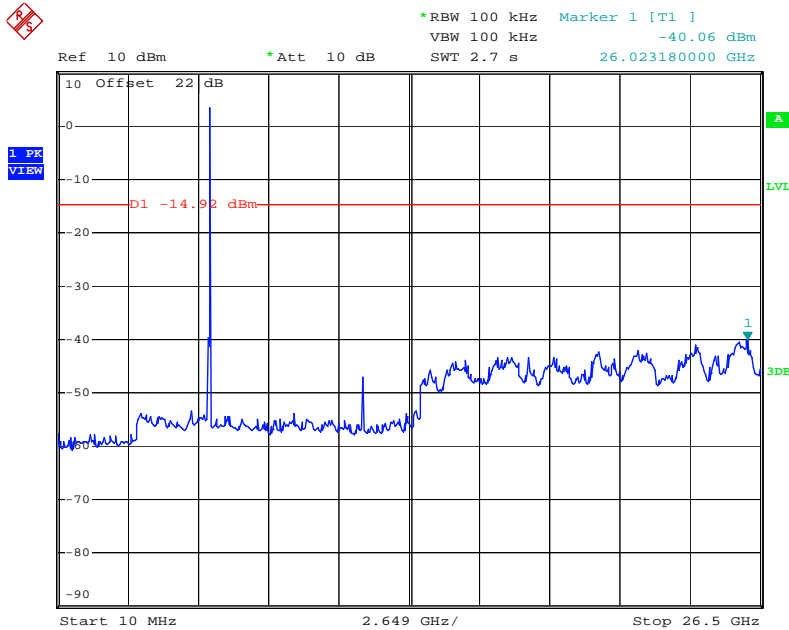

Date: 15.JAN.2008 00:00:07

The results shown in this test report refer only to the sample(s) tested unless otherwise stated. This test report cannot be reproduced, except in full, without prior written permission of the Company.

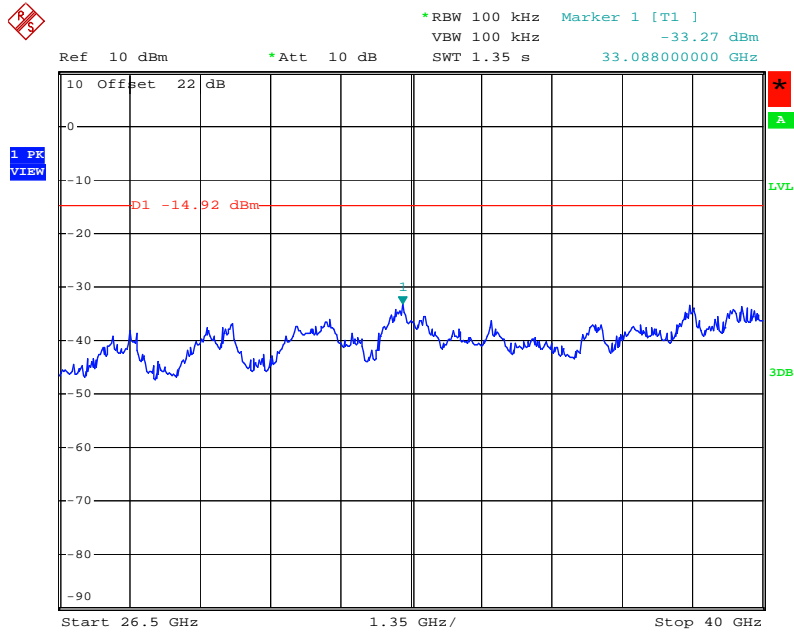

Date: 15.JAN.2008 00:00:31

*The results shown in this test report refer only to the sample(s) tested unless otherwise stated. This test report cannot be reproduced, except in full, without prior written permission of the Company.*

## Middle Channel

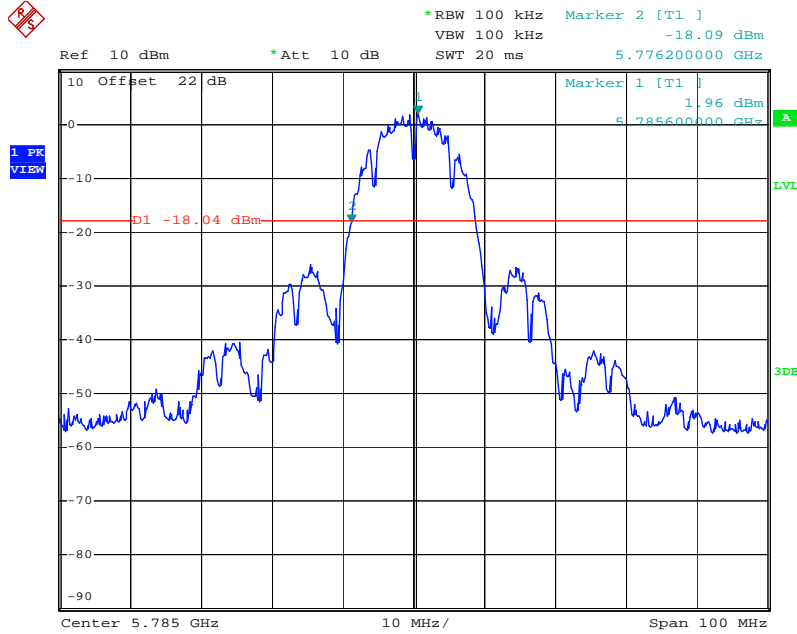

Date: 15.JAN.2008 00:05:30

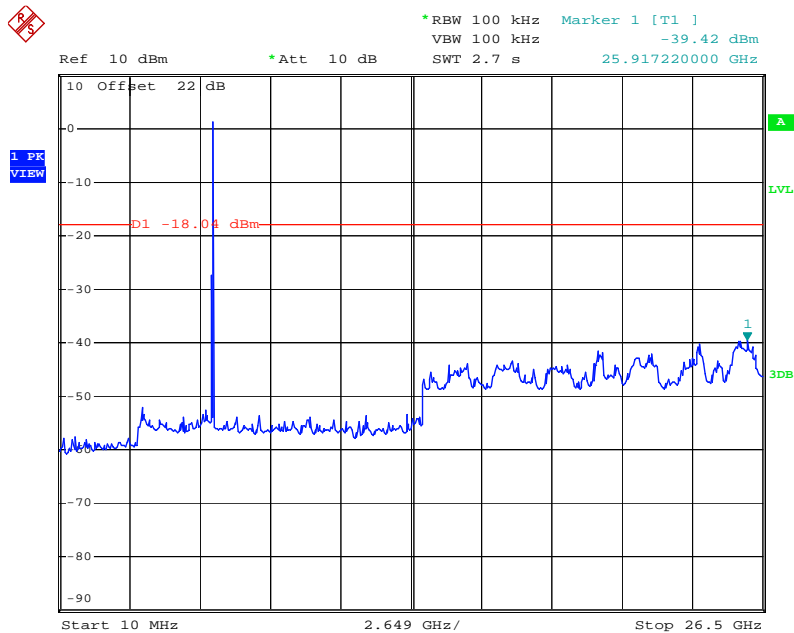

Date: 15.JAN.2008 00:06:06

The results shown in this test report refer only to the sample(s) tested unless otherwise stated. This test report cannot be reproduced, except in full, without prior written permission of the Company.

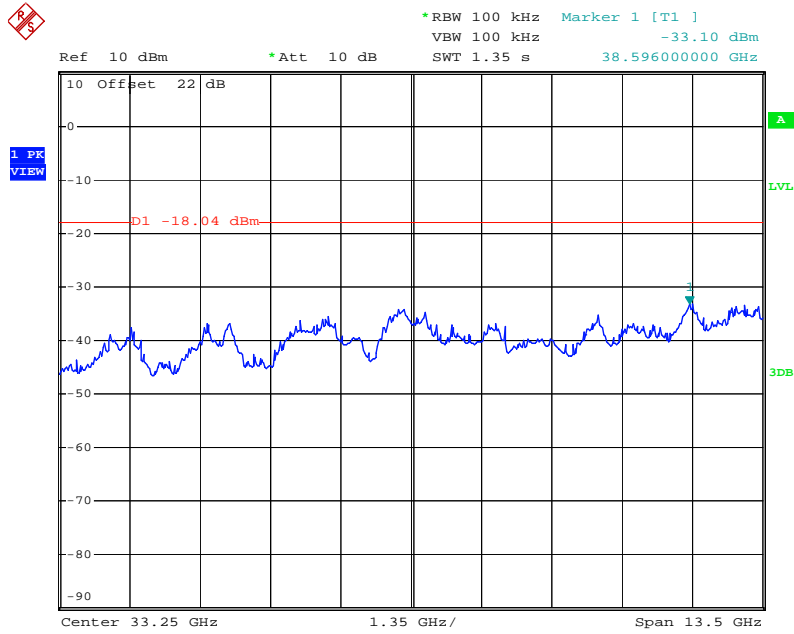

Date: 15.JAN.2008 00:06:32

*The results shown in this test report refer only to the sample(s) tested unless otherwise stated. This test report cannot be reproduced, except in full, without prior written permission of the Company.*

## High Channel

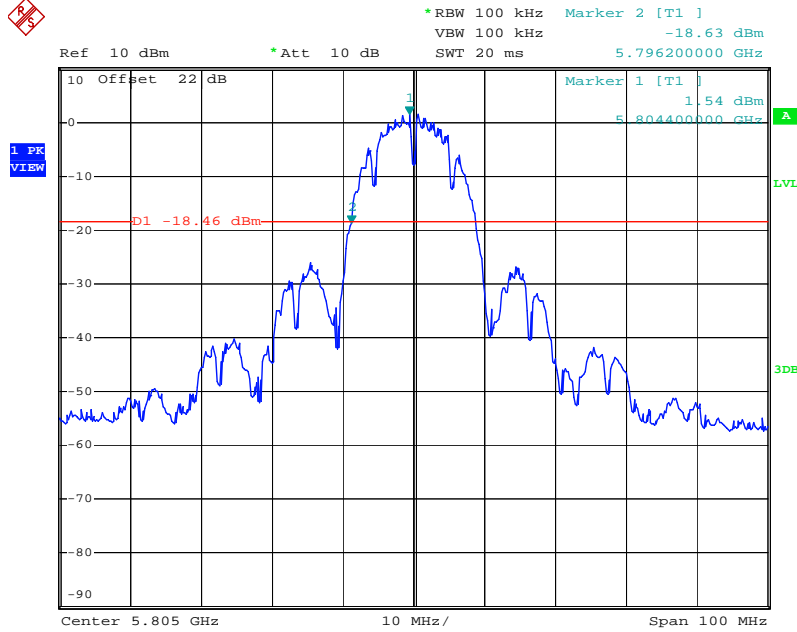

Date: 15.JAN.2008 00:01:48

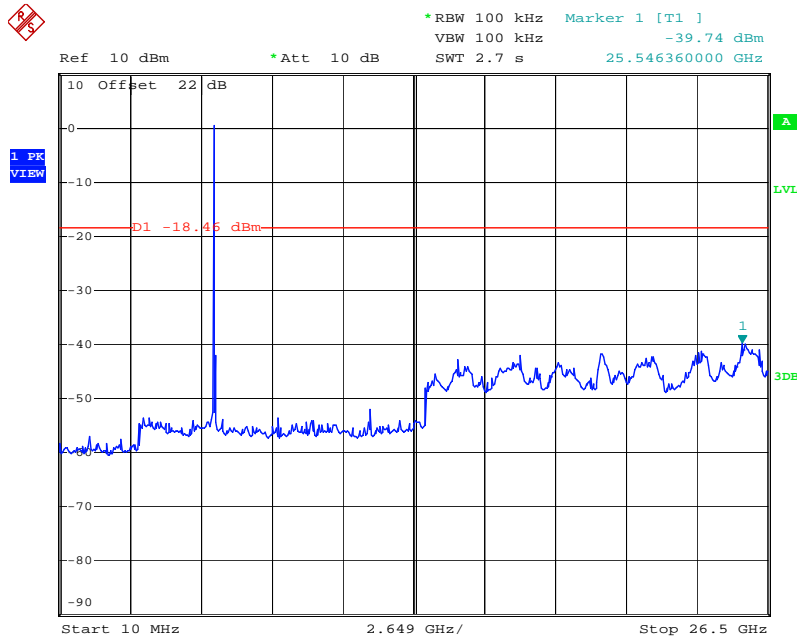

Date: 15.JAN.2008 00:02:21

The results shown in this test report refer only to the sample(s) tested unless otherwise stated. This test report cannot be reproduced, except in full, without prior written permission of the Company.

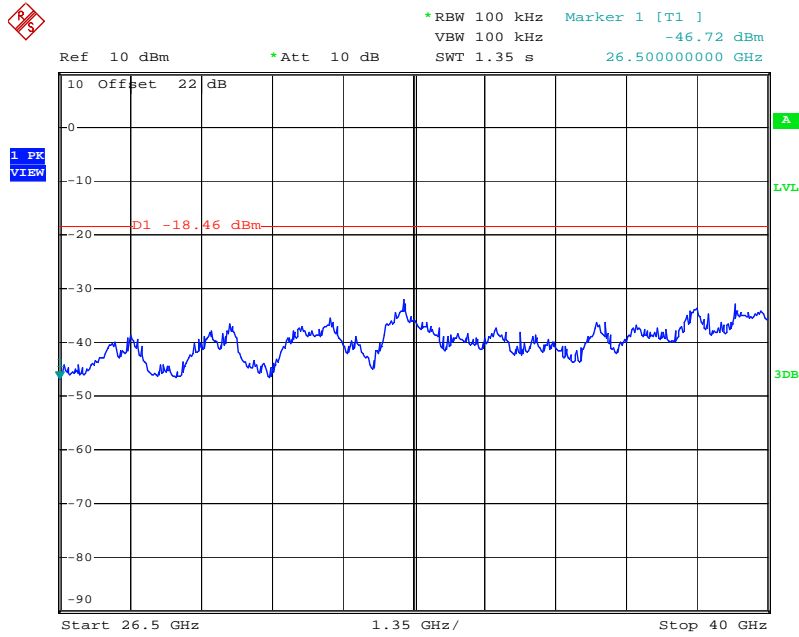

Date: 15.JAN.2008 00:02:50

*The results shown in this test report refer only to the sample(s) tested unless otherwise stated. This test report cannot be reproduced, except in full, without prior written permission of the Company.*

## 5. Receiver Radiated spurious emissions

### 5.1. Test setup - Same as clause 4.1.

#### 5.1.1. Receiver Radiated Spurious Emissions - Same as clause 4.1.1.

### 5.2. Limit

According to §15.109(a), Except for Class A digital devices, the field strength of radiated emission from unintentional radiator at a distance of 3 m shall not exceed the following values:

Frequency (MHz)	Distance (Meters)	Radiated (dB $\mu$ V/m)	Radiated ( $\mu$ V/m)
30 - 88	3	40.0	100
88 – 216	3	43.5	150
216 – 960	3	46.0	200
Above 960	3	54.0	500

### 5.3. Test Procedures - Same as clause 4.3.

Radiated emissions from the EUT were measured according to the dictates of ANSI C63.4:2003

#### 5.3.1. Test Procedures for Radiated Spurious Emissions- Same as clause 4.3.1.

*The results shown in this test report refer only to the sample(s) tested unless otherwise stated. This test report cannot be reproduced, except in full, without prior written permission of the Company.*

## 5.4. Test Results

Ambient temperature : 21 Relative humidity : 43 %

### 5.4.1. Spurious Radiated Emission (Worst case mode)

All emissions are not reported much lower than the prescribed limits. All reading values are quasi-peak values.

Radiated Emissions			Ant	Correction Factors		Total	FCC Limit	
Frequency (MHz)	Reading (dBuV)	Detect Mode	Pol.	AF (dB/m)	CL (dB)	Actual (dBuV/m)	Limit (dBuV/m)	Margin (dB)
39.700	18.54	Q.P.	V	14.16	0.81	33.51	40.00	6.49
299.175	21.45	Q.P.	V	10.97	2.27	34.69	46.00	11.31
447.100	18.30	Q.P.	V	15.38	2.85	36.53	46.00	9.47
595.025	12.50	Q.P.	V	16.83	3.22	32.55	46.00	13.45
740.525	12.01	Q.P.	V	18.81	3.62	34.44	46.00	11.56
888.450	11.25	Q.P.	V	20.46	4.02	35.73	46.00	10.27
Above 890.00	Not Detected	-	-	-	-	-	-	-

#### Remark:

1. All spurious emission at channels are almost the same below 1 GHz, so that the channel was chosen at representative in final test.
2. “\*” means the restricted band.
3. Actual = Reading + AF + CL

*The results shown in this test report refer only to the sample(s) tested unless otherwise stated. This test report cannot be reproduced, except in full, without prior written permission of the Company.*

## 6. 6 dB Bandwidth Measurement and 99 % BW

### 6.1. Test Setup

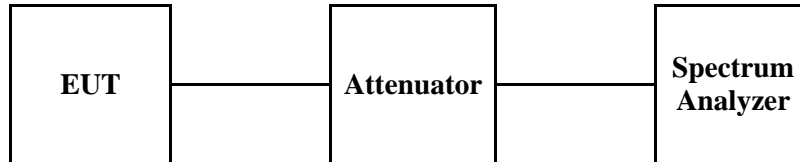

### 6.2. Limit

According to §15.247(a)(2), systems using digital modulation techniques may operate in the 902 ~928 MHz , 2400 ~ 2483.5 MHz, and 5725 ~ 5825 MHz bands. The minimum of 6 dB Bandwidth shall be at least 500 kHz

### 6.3. Test Procedure

1. Place the EUT on the table and set it in the transmitting mode.
2. Remove the antenna from the EUT and then connect a low loss RF cable from the antenna port to the spectrum analyzer.
3. Set the spectrum analyzer as RBW = 100 kHz, VBW = RBW, Span = 20 MHz, Sweep = auto.
4. Mark the peak frequency and -6 dB (upper and lower) frequency.
5. Repeat until all the rest channels are investigated.

*The results shown in this test report refer only to the sample(s) tested unless otherwise stated. This test report cannot be reproduced, except in full, without prior written permission of the Company.*

### 6.4. Test Results

Ambient temperature : 22                      Relative humidity : 48 %

Channel	Channel Frequency (MHz)	6 dB Bandwidth (MHz)	Minimum Limit (MHz)
Low	5745	9.80	0.5
Middle	5785	9.88	
High	5805	9.84	

Channel	Channel Frequency (MHz)	99 % Bandwidth (MHz)	Remake
Low	5745	16.10	
Middle	5785	16.10	
High	5805	15.96	

*The results shown in this test report refer only to the sample(s) tested unless otherwise stated. This test report cannot be reproduced, except in full, without prior written permission of the Company.*

Low Channel

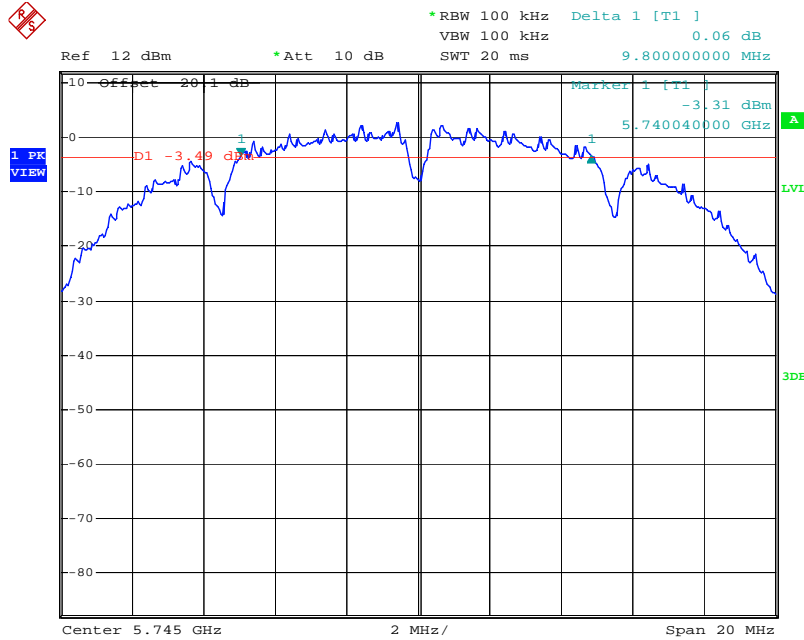

Date: 10.JAN.2008 17:10:11

Middle Channel

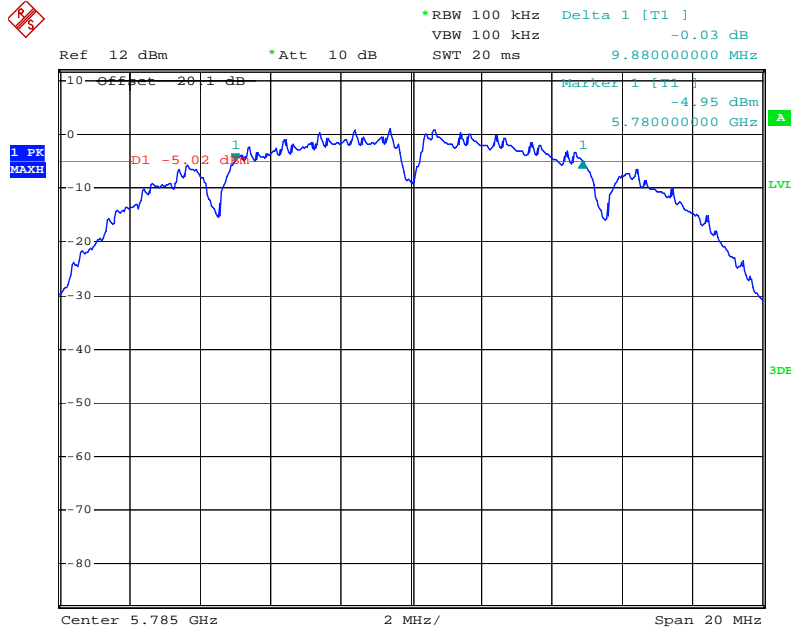

Date: 10.JAN.2008 17:11:19

The results shown in this test report refer only to the sample(s) tested unless otherwise stated. This test report cannot be reproduced, except in full, without prior written permission of the Company.

## High Channel

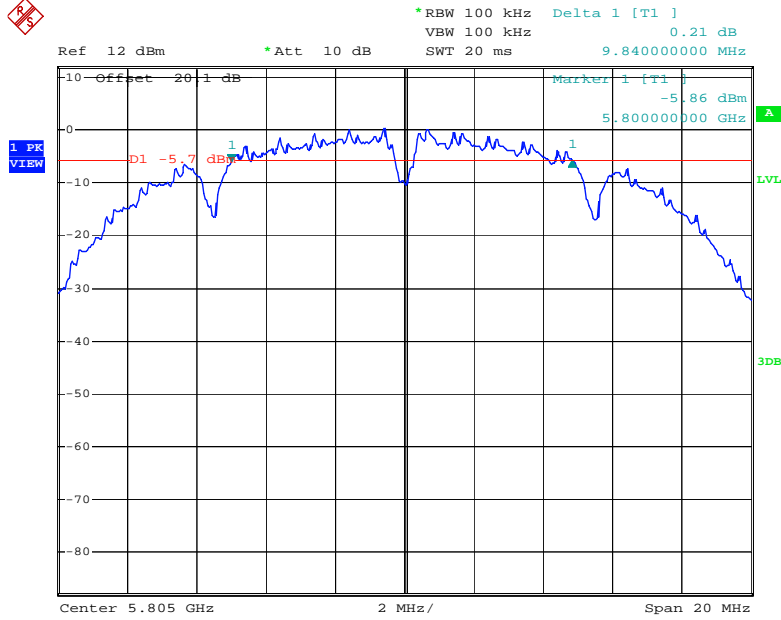

Date: 10.JAN.2008 17:12:40

The results shown in this test report refer only to the sample(s) tested unless otherwise stated. This test report cannot be reproduced, except in full, without prior written permission of the Company.

## 99 % Bandwidth

### Low Channel

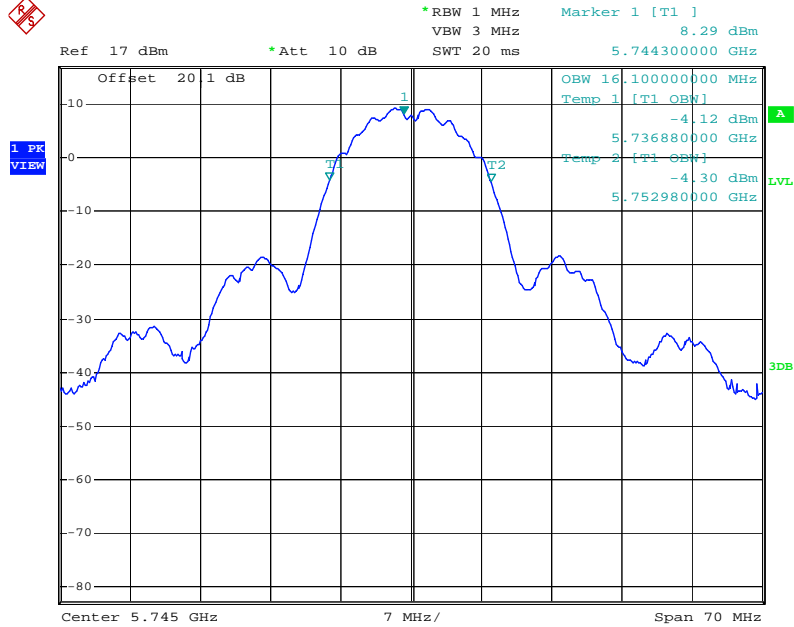

Date: 10.JAN.2008 17:15:33

### Middle Channel

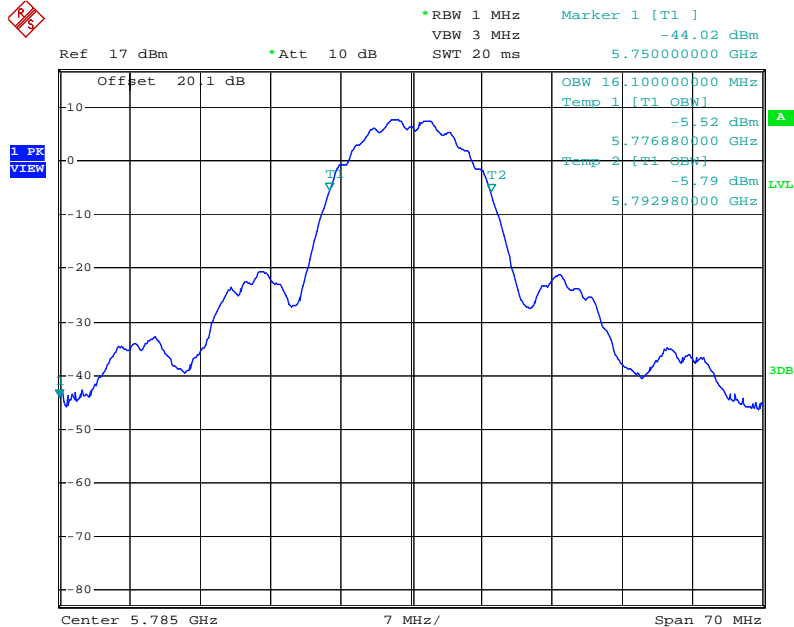

Date: 10.JAN.2008 17:16:19

The results shown in this test report refer only to the sample(s) tested unless otherwise stated. This test report cannot be reproduced, except in full, without prior written permission of the Company.

## High Channel

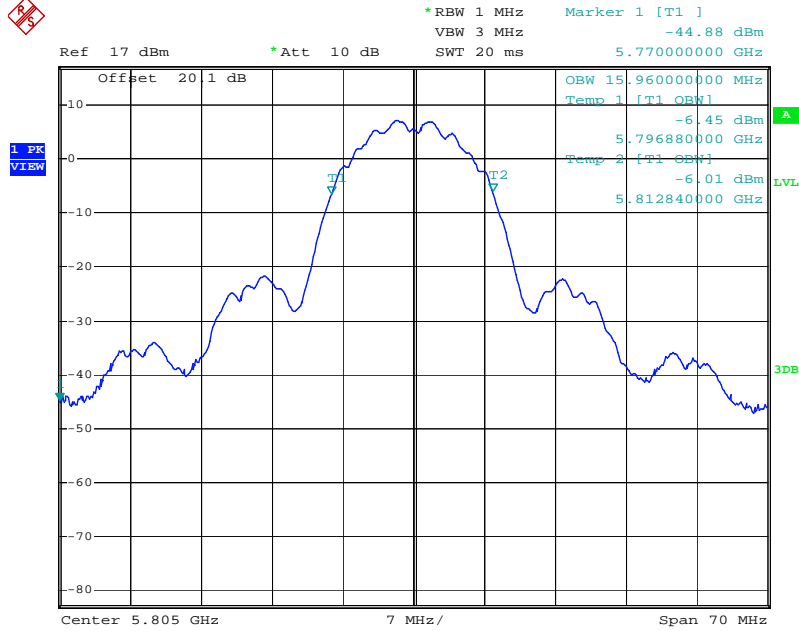

Date: 10.JAN.2008 17:16:55

The results shown in this test report refer only to the sample(s) tested unless otherwise stated. This test report cannot be reproduced, except in full, without prior written permission of the Company.

## 7. Maximum Peak Output Power Measurement

### 7.1. Test Setup

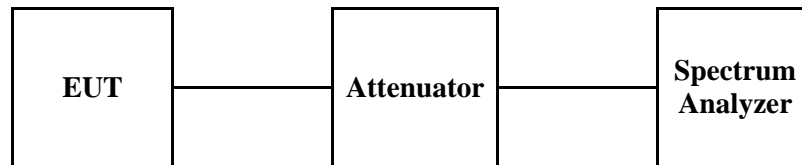

### 7.2. Limit

According to §15.247(b)(3), for systems using digital modulation in the 902 ~ 928 MHz, 2400 ~2483.5 MHz, and 5725 ~ 5850 MHz band: 1 Watt. As an alternative to a peak power measurement, compliance with the one watt limit can be based on a measurement of the maximum conducted output power. Maximum Conducted output Power is defined as the total transmit power delivered to all antennas and antenna elements averaged across all symbols in the signaling alphabet when the transmitter is operating at its maximum power control level. Power must be summed across all antenna elements. The average must not include any intervals during which the transmitter is off or is transmitting at a reduced power level. If multiple modes of operation are possible (e.g., alternative modulation methods), the maximum conducted output power is the highest total transmit power occurring in any mode.

According to §15.247(b)(4), the conducted output power limit specified in paragraph(b) of this section is based on the use of antenna with directional gains that do not exceed 6 dBi. Except as shown in paragraph(c) of this section, if transmitting antenna of directional gain greater than 6 dBi are used, the conducted output power from the intentional radiator shall be reduced below the stated values in paragraph (b)(1), (b)(2), and (b)(3) of this section , as appropriate, by the amount in dB that the directional gain of the antenna exceeds 6dBi.

### 7.3. Test Procedure

1. Place the EUT on the table and set it in the transmitting mode.
2. Remove the antenna from the EUT and then connect a low loss RF cable from the antenna port to the spectrum analyzer.
3. Set the Spectrum analyzer as RBW = 1 MHz, VBW = 3 MHz, Span = Auto, Channel BW = 99%.

*The results shown in this test report refer only to the sample(s) tested unless otherwise stated. This test report cannot be reproduced, except in full, without prior written permission of the Company.*

### 7.4. Test Results

Ambient temperature : 22      Relative humidity : 48 %

Channel	Channel Frequency (MHz)	Peak Power Output (dBm)	Peak Power Limit (dBm)	Margin (dB)
Low	5745	17.37	30	12.63
Middle	5785	15.89		14.11
High	5805	15.09		14.91

#### Low Channel

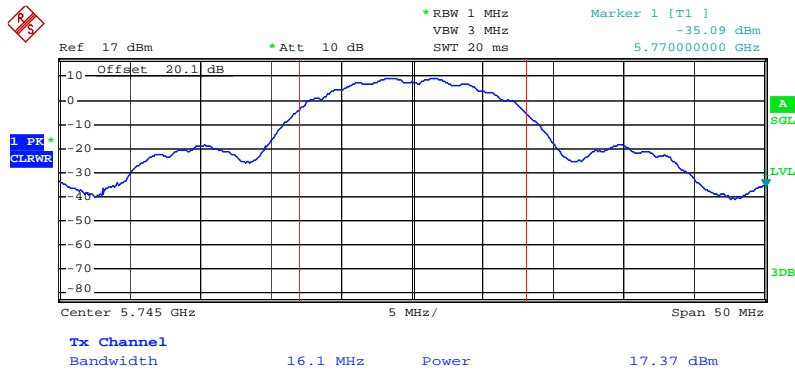

Date: 10.JAN.2008 17:20:41

The results shown in this test report refer only to the sample(s) tested unless otherwise stated. This test report cannot be reproduced, except in full, without prior written permission of the Company.

Middle Channel

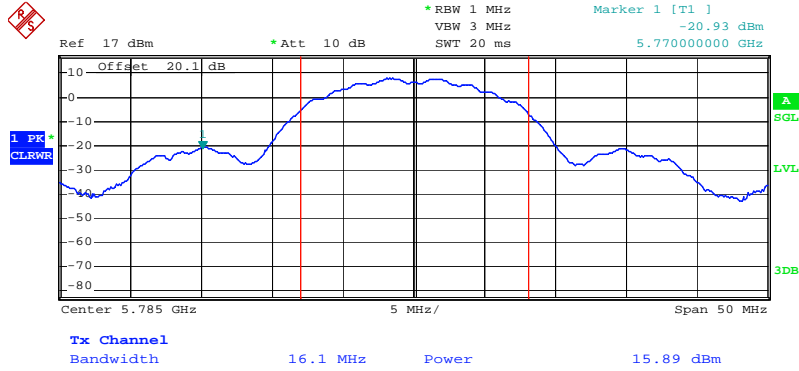

Date: 10.JAN.2008 17:21:16

High Channel

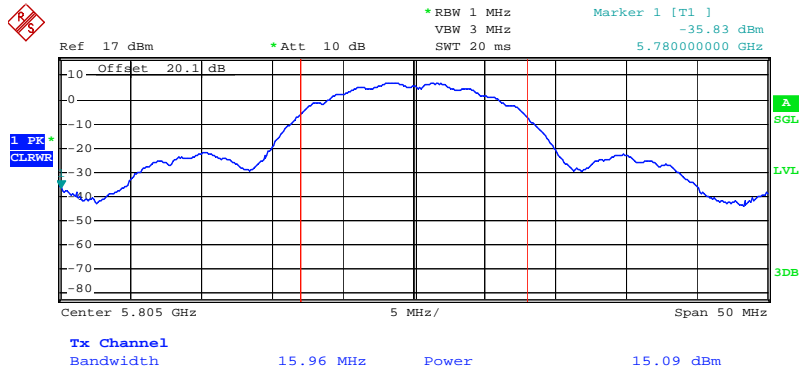

Date: 10.JAN.2008 17:21:59

The results shown in this test report refer only to the sample(s) tested unless otherwise stated. This test report cannot be reproduced, except in full, without prior written permission of the Company.

## 8. Power Spectral Density Measurement

### 8.1. Test Setup

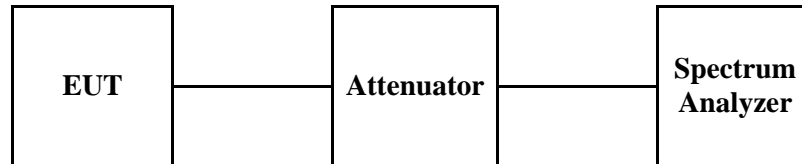

### 8.2. Limit

According to §15.247(e), For digitally modulated system, the power spectral density conducted from the intentional radiator to the antenna shall not be greater than 8 dBm in any 3 kHz band any time interval of continuous transmission. This power spectral density shall be determined in accordance with the provisions of paragraph(b) of this section. The same method of determining the conducted output power shall be used to determine the power spectral density

### 8.3. Test Procedure

1. Place the EUT on the table and set it in transmitting mode  
Remove the antenna from the EUT and then connect a low loss RF cable from the antenna port to the spectrum analyzer.
2. Set the spectrum analyzer as RBW = 3 kHz, VBW = 10 kHz, Span = 300 kHz, Sweep = 100 s
3. Record the max reading.
4. Repeat the above procedure until the measurements for all frequencies are completed.

### 8.4. Test Results

Ambient temperature : 22                      Relative humidity : 48 %

Channel	Channel Frequency (MHz)	Final RF Power Level in 3 kHz BW (dBm)	Maximum Limit (dBm)	Margin (dB)
Low	5745	-16.86	8	24.86
Middle	5785	-18.04		26.04
High	5805	-18.92		26.92

#### Low Channel

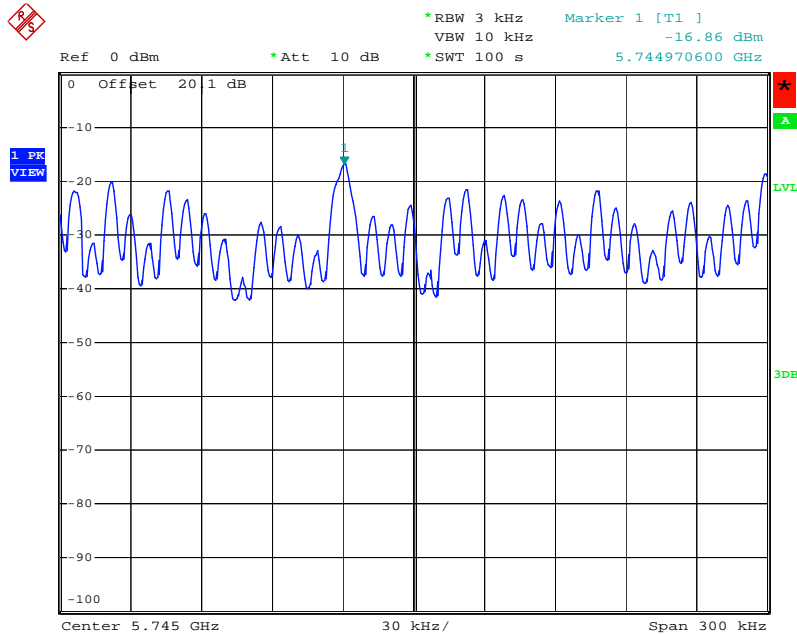

Date: 10.JAN.2008 17:32:48

The results shown in this test report refer only to the sample(s) tested unless otherwise stated. This test report cannot be reproduced, except in full, without prior written permission of the Company.

### Middle Channel

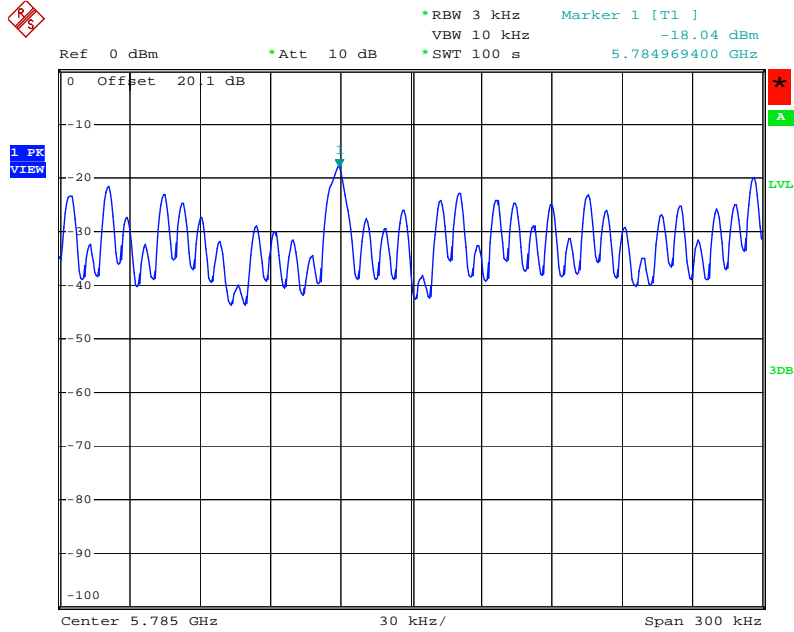

Date: 10.JAN.2008 17:28:05

### High Channel

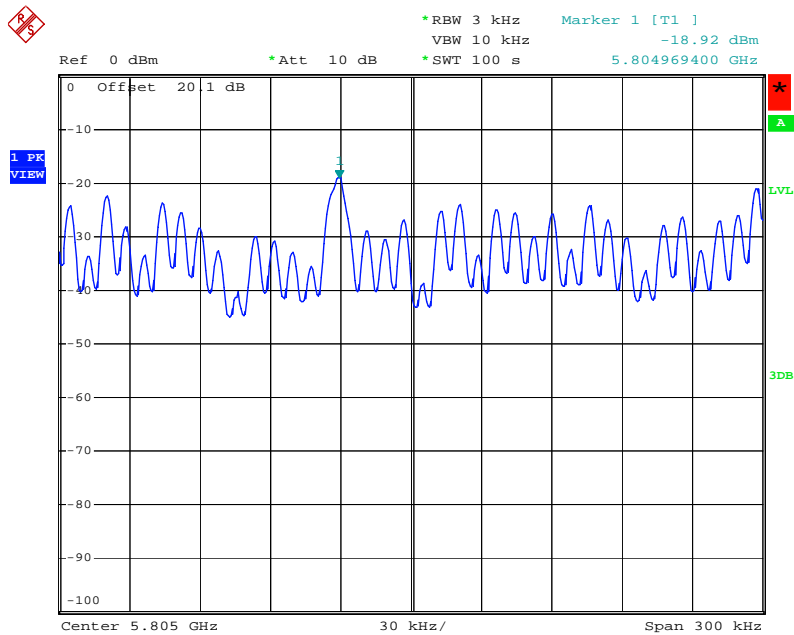

Date: 10.JAN.2008 17:30:26

The results shown in this test report refer only to the sample(s) tested unless otherwise stated. This test report cannot be reproduced, except in full, without prior written permission of the Company.

## 9. Antenna Requirement

### 9.1. Standard Applicable

For intentional device, according to FCC 47 CFR Section §15.203, an intentional radiator shall be designed to ensure that no antenna other than that furnished by the responsible party shall be used with the device. And according to FCC 47 CFR Section § 15.247 (b), if transmitting antennas of directional gain greater than 6 dBi are used, the power shall be reduced by the amount in dB that the gain of the antenna exceeds 6 dBi.

### 9.2. Antenna Connected Construction

Antenna used in this product is connected in FIFA Type of -1.22 dBi (5.7 GHz)

## 10. RF Exposure Evaluation

According to FCC 1.1310 : The criteria listed in the following table shall be used to evaluate the environment impact of human exposure to radio frequency (RF) radiation as specified in § 1.1307(b)

### LIMITS FOR MAXIMUM PERMISSIBLE EXPOSURE (MPE)

Frequency Range (MHz)	Electric Field Strength(V/m)	Magnetic Field Strength (A/m)	Power Density (mW/cm <sup>2</sup> )	Average Time
<b>(A) Limits for Occupational /Control Exposures</b>				
<b>300 – 1500</b>	--	--	<b>F/300</b>	<b>6</b>
<b>1500 - 100000</b>	--	--	<b>5</b>	<b>6</b>
<b>(B) Limits for General Population/Uncontrol Exposures</b>				
<b>300 – 1500</b>	--	--	<b>F/1500</b>	<b>6</b>
<b>1500 - 100000</b>	--	--	<b>1</b>	<b>30</b>

### 10.1 Friis transmission formula : $P_d = (P_{out} * G) / (4 * \pi * R^2)$

Where

$P_d$  = power density in mW/cm<sup>2</sup>

$P_{out}$  = output power to antenna in mW

$G$  = gain of antenna in linear scale

$\pi$  = 3.1416

$R$  = distance between observation point and center of the radiator in cm

$P_d$  the limit of MPE, 1 mW/cm<sup>2</sup>. If we know the maximum gain of the antenna and the total power input to the antenna, through the calculation, we will know the distance where the MPE limit is reached.

*The results shown in this test report refer only to the sample(s) tested unless otherwise stated. This test report cannot be reproduced, except in full, without prior written permission of the Company.*

## 10.1 Test Result of RF Exposure Evaluation

Test Item : RF Exposure Evaluation Data

Test Mode : Normal Operation

### 10.1.1 Output Power into Antenna & RF Exposure Evaluation Distance

Operating Mode: DSSS

Channel	Channel Frequency (MHz)	Output Peak Power to Antenna (dBm)	Antenna Gain (dBi)	Power Density at 20cm (mW/cm <sup>2</sup> )	Limits (mW/cm <sup>2</sup> )
Low	5745	17.37	-1.22	0.00820	1
Middle	5785	15.89	-1.22	0.00583	1
High	5805	15.09	-1.22	0.00485	1

*The results shown in this test report refer only to the sample(s) tested unless otherwise stated. This test report cannot be reproduced, except in full, without prior written permission of the Company.*

**Appendix A-1. Photo of Field Strength Test**

---

*The results shown in this test report refer only to the sample(s) tested unless otherwise stated. This test report cannot be reproduced, except in full, without prior written permission of the Company.*

**Appendix A -2. Photos of Conducted Power Line Test**

*The results shown in this test report refer only to the sample(s) tested unless otherwise stated. This test report cannot be reproduced, except in full, without prior written permission of the Company.*

## Appendix B. Photos of the EUT

### Front View of EUT



### Rear View of EUT



*The results shown in this test report refer only to the sample(s) tested unless otherwise stated. This test report cannot be reproduced, except in full, without prior written permission of the Company.*

## Inner of EUT

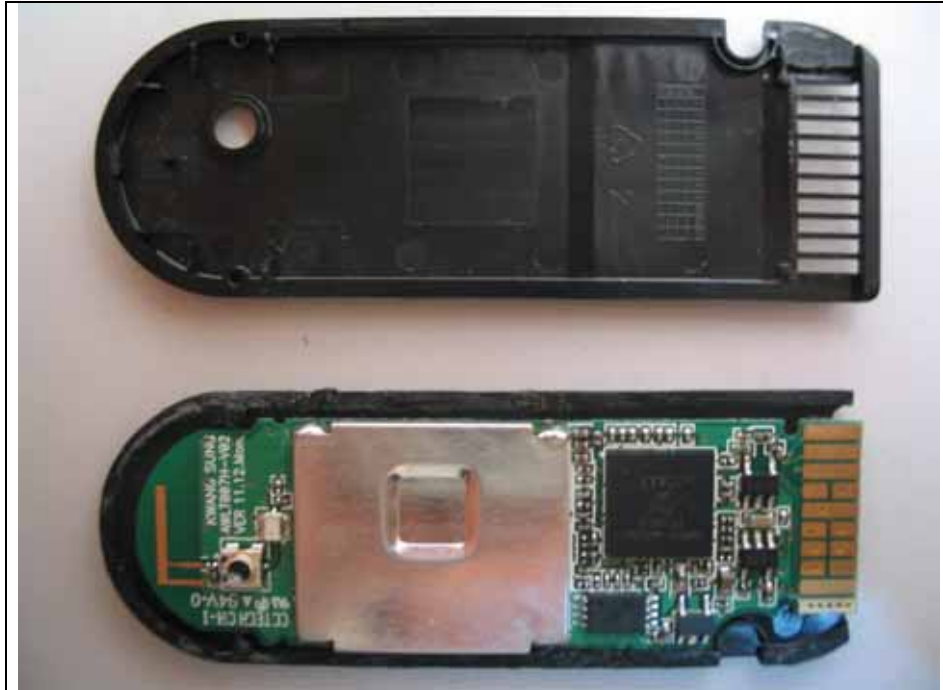

## Top View of Main-board



*The results shown in this test report refer only to the sample(s) tested unless otherwise stated. This test report cannot be reproduced, except in full, without prior written permission of the Company.*

**Top View of Main-board (Removal Shield Cap)**

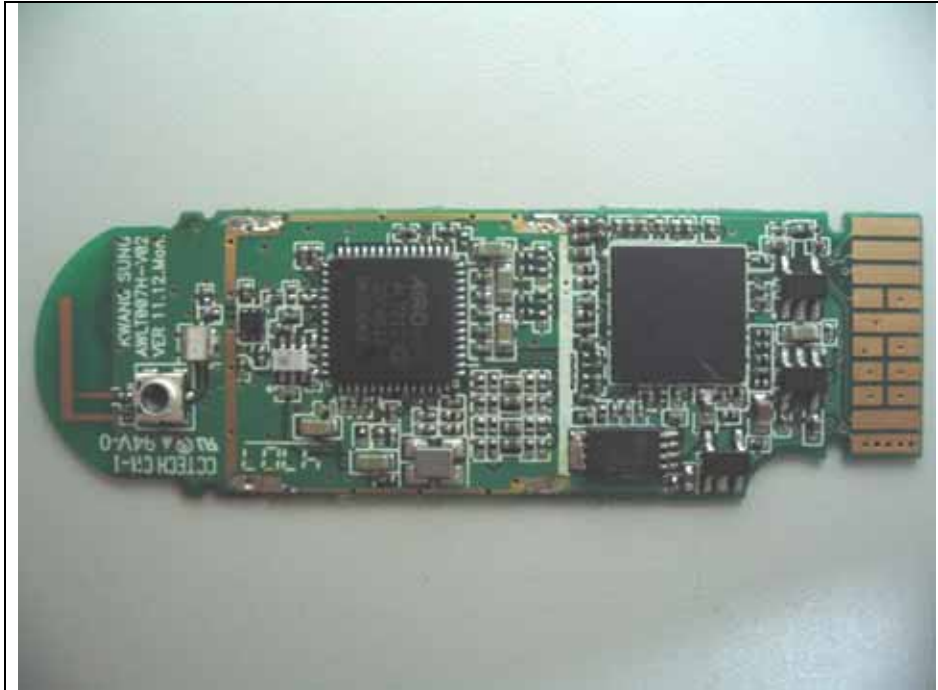

**Bottom View of Main-board**



*The results shown in this test report refer only to the sample(s) tested unless otherwise stated. This test report cannot be reproduced, except in full, without prior written permission of the Company.*

**View of Antenna**

*The results shown in this test report refer only to the sample(s) tested unless otherwise stated. This test report cannot be reproduced, except in full, without prior written permission of the Company.*