

Title		
Mini USB 2.0 PEN TYPE System - RT2571W + RT2528		
Size	Document Number	Rev
B	WUG2700_E2.SCH	1.0
Date:	Thursday, March 08, 2007	Sheet 1 of 5

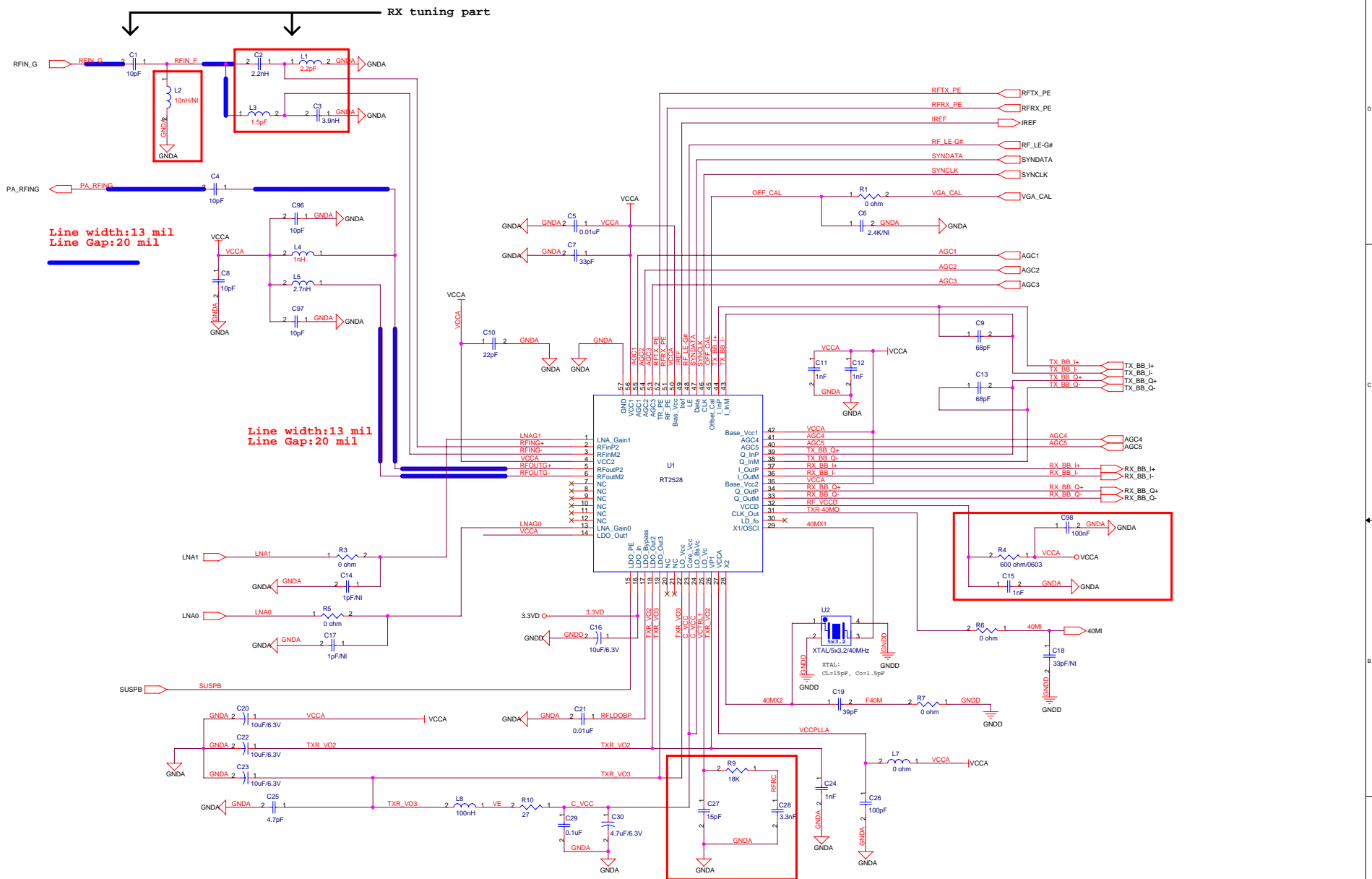

Transceiver - RT2528		
File	Document Number	
Size	1-RT2528-XTAL_SCH	Rev
C		1.0
Date	Thursday, March 08, 2007	Sheet 2 of 5

	TX	RX
VC1	3.3V	0V
VC2	0V	3.3V

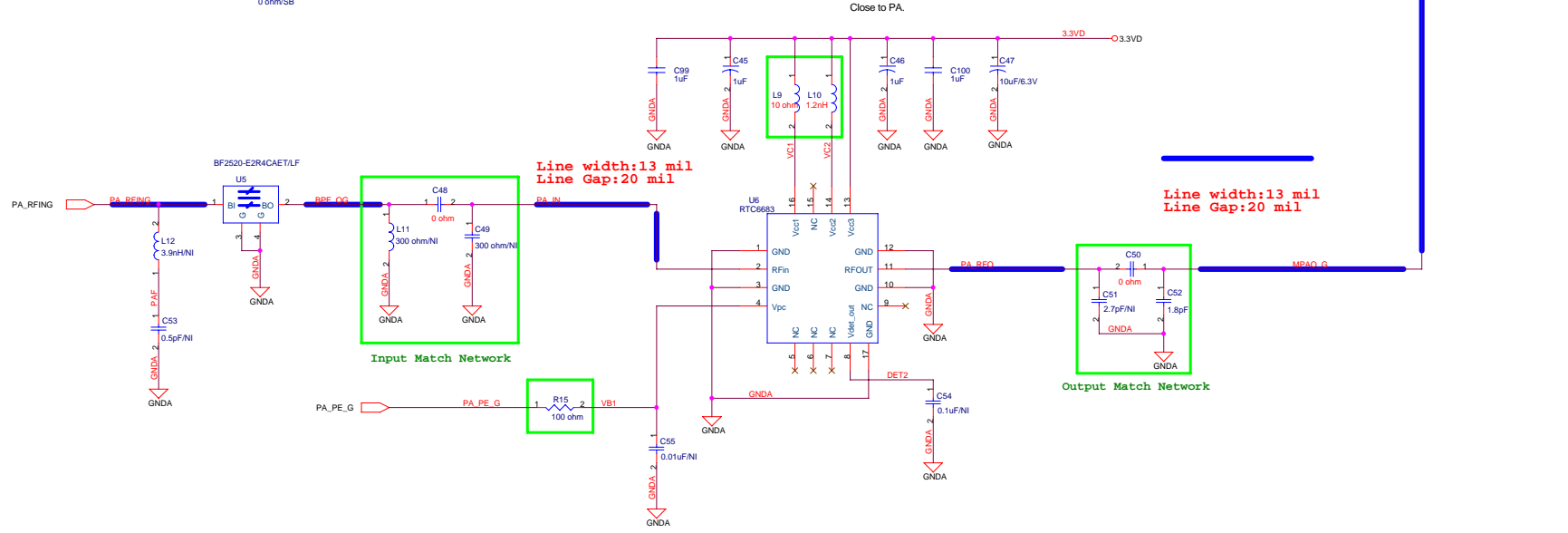
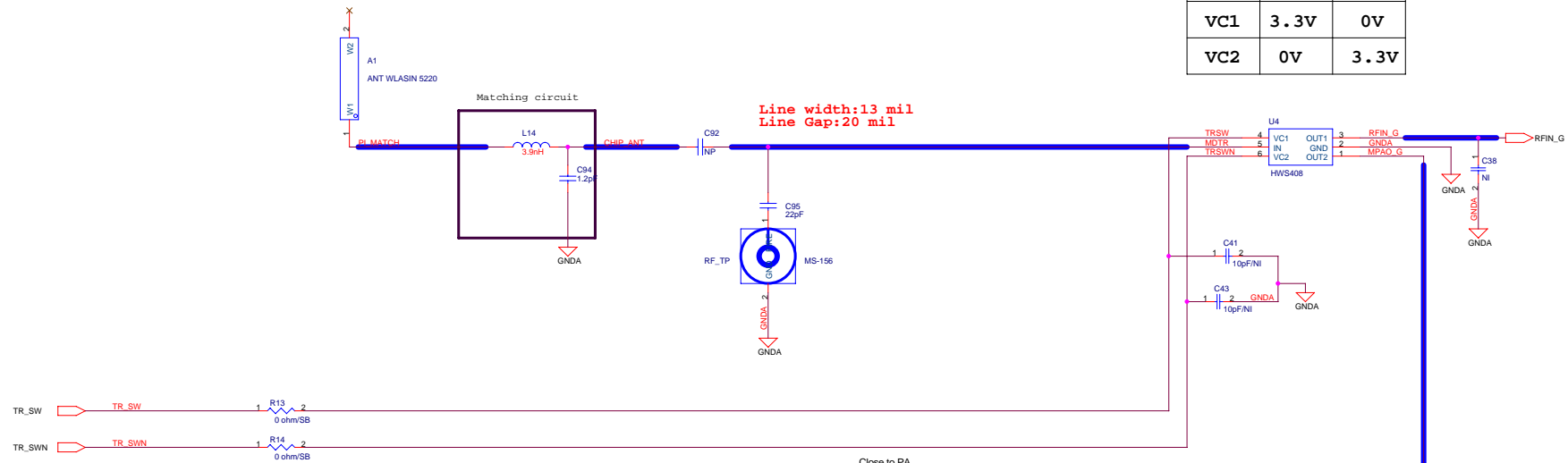

File		
PA and TX/RX		
Size	Document Number	Rev
C	2-PA-RTC6683.SCH	1.0
Date	Thursday, March 08, 2007	Sheet 3 of 5

DiffLine width:12 mil  
 DiffLine Spread:8.5 mil  
 DiffLine Gap:20 mil  
 等長

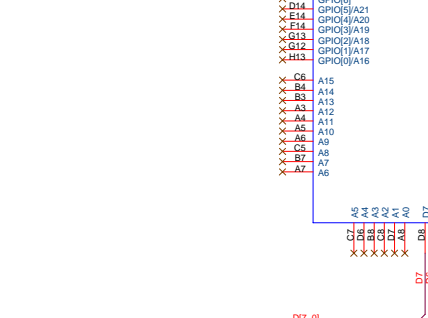
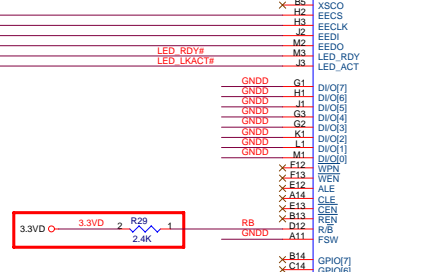
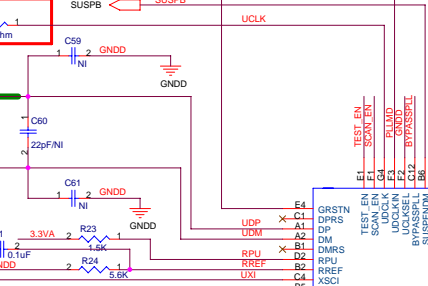
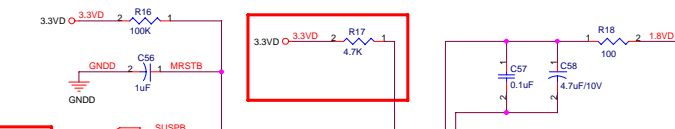
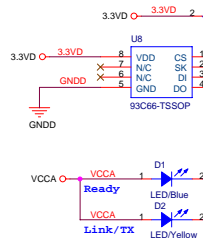
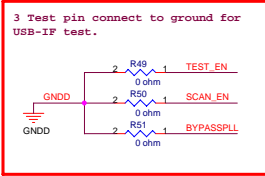

U7  
 RT2571W-TFBGA180

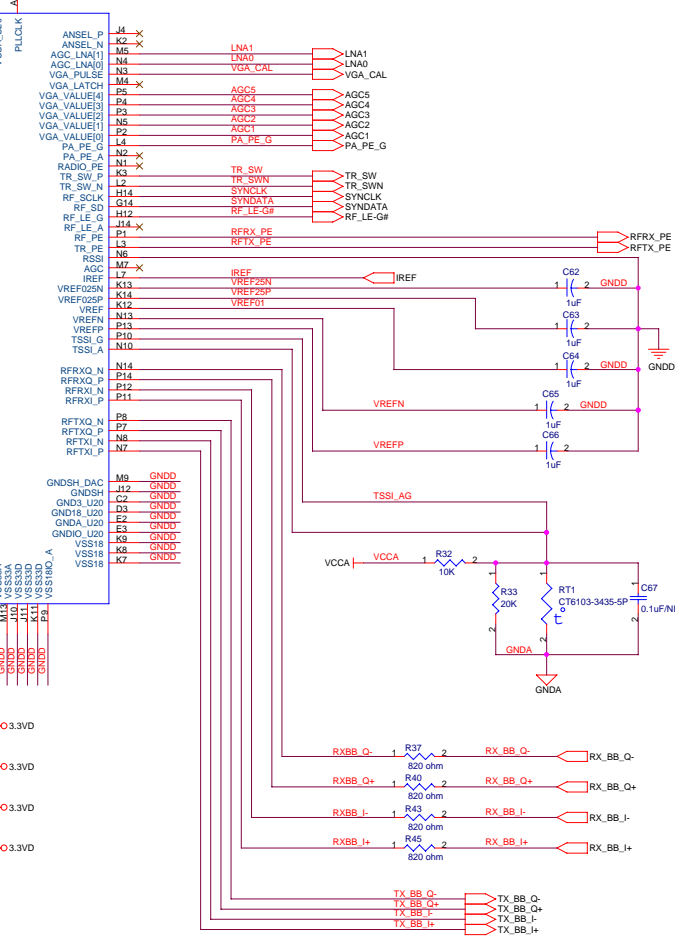
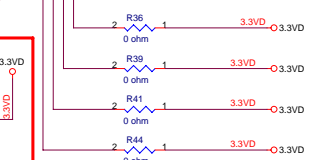
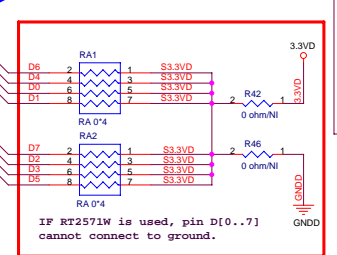
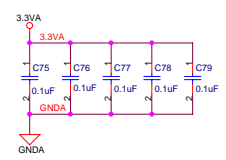
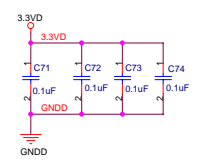
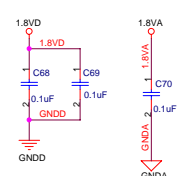

File WLAN MAC+BBP - RT2571W		
Size C	Document Number 3-RT2571W.SCH	Rev 1.0
Date Thursday, March 08, 2007	Sheet 4	of 5

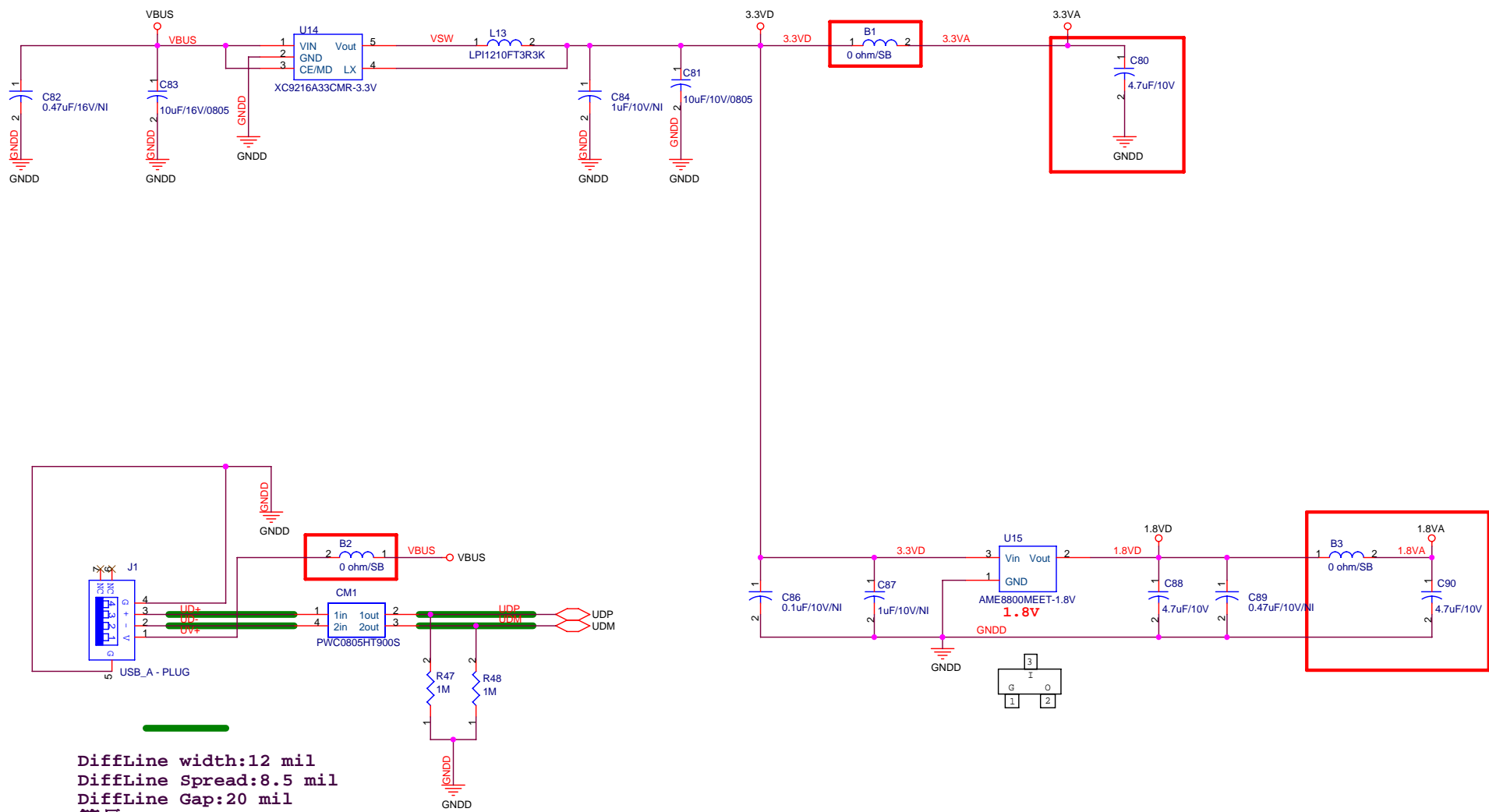

DiffLine width:12 mil  
 DiffLine Spread:8.5 mil  
 DiffLine Gap:20 mil  
 等長

Title		
PEN USB Interface and Power		
Size	Document Number	Rev
B	4-USB-A.SCH	1.0
Date:	Thursday, March 08, 2007	Sheet 5 of 5