

# TEST REPORT

of

FCC Part 15 Subpart B&amp;C §15.247/ RSS-210 Issue 8, RSS-Gen Issue 3

FCC ID/IC Certification: A3LBKC-1B1/649E-BKC1B1

Equipment Under Test : Bluetooth KEY BOARD  
Model Name : BKC-1B1  
Serial No. : N/A  
Applicant : SAMSUNG ELECTRONICS CO., LTD.  
Manufacturer : SAMSUNG ELECTRONICS CO., LTD.  
Date of Test(s) : 2011. 06. 13 ~ 2011. 06. 20  
Date of Issue : 2011. 06. 21

In the configuration tested, the EUT complied with the standards specified above.

Tested By:



Date

2011. 06. 21

Duke Ko

Approved By



Date

2011. 06. 21

Feel Jeong

*The results shown in this test report refer only to the sample(s) tested unless otherwise stated. This test report cannot be reproduced, except in full, without prior written permission of the Company.*

# INDEX

<u>Table of Contents</u>	Page
1. General Information -----	3
2. Transmitter Radiated Spurious Emissions and Conducted Spurious Emission -----	7
3. Receiver Radiated Spurious Emission-----	17
4. 20 dB Bandwidth and 99% BW -----	19
5. Maximum Peak Output Power -----	25
6. Hopping Channel Separation -----	27
7. Number of Hopping Frequency -----	30
8. Time of Occupancy(Dwell Time) -----	33
9. Antenna Requirement -----	37
10. RF Exposure evaluation -----	38

*The results shown in this test report refer only to the sample(s) tested unless otherwise stated. This test report cannot be reproduced, except in full, without prior written permission of the Company.*

## 1. General Information

### 1.1. Testing Laboratory

SGS Korea Co., Ltd. (Gunpo Laboratory)  
 Wireless Div. 2FL, 18-34, Sanbon-dong, Gunpo-si, Gyeonggi-do, Korea 435-040  
[www.kr.sgs.com/ee](http://www.kr.sgs.com/ee)  
 Telephone : +82 +31 428 5700  
 FAX : +82 +31 427 2371

### 1.2. Details of Applicant

Applicant : SAMSUNG ELECTRONICS CO.,LTD.  
 Address : 416, Maetan-dong, Yeongtong-gu, Suwon-si, Gyeonggi-do, Korea  
 Contact Person : Yoo, Jung Heon  
 Phone No. : +82 +10 2799 7746

### 1.3. Description of EUT

<b>Kind of Product</b>	Bluetooth KEY BOARD
<b>Model Name</b>	BKC-1B1
<b>Serial Number</b>	N / A
<b>Power Supply</b>	DC 3.7 V (Li-ion Battery)
<b>Frequency Range</b>	2 402 ~ 2 480 MHz
<b>Modulation Technique</b>	GFSK
<b>Number of Channels</b>	79
<b>Antenna Type</b>	Integral Type (Chip Antenna)
<b>Antenna Gain</b>	1.99 dBi
<b>H/W Version</b>	REV1.0C
<b>S/W Version</b>	BKC-1B1_SW01

### 1.4. Declaration by the manufacturer

- The EUT does not do anything at charging mode
  - H/W Version is changed.
- (Electric parts and PCB layer changed)

*The results shown in this test report refer only to the sample(s) tested unless otherwise stated. This test report cannot be reproduced, except in full, without prior written permission of the Company.*

## 1.5. Information about the FHSS characteristics:

### 1.5.1. Pseudorandom Frequency Hopping Sequence

The channel is represented by a pseudo-random hopping sequence hopping through the 79 RF channels. The hopping sequence is unique for the piconet and is determined by the Bluetooth device address of the master; the phase in the hopping sequence is determined by the Bluetooth clock of the master. The channel is divided into time slots where each slot corresponds to an RF hop frequency. Consecutive hops correspond to different RF hop frequencies. The nominal hop rate is 1 600 hops/s.

### 1.5.2. Equal Hopping Frequency Use

All Bluetooth units participating in the piconet are time and hop-synchronized to the channel.

### 1.5.3. System Receiver Input Bandwidth

Each channel bandwidth is 1 MHz

---

*The results shown in this test report refer only to the sample(s) tested unless otherwise stated. This test report cannot be reproduced, except in full, without prior written permission of the Company.*

### 1.6. Test Equipment List

Equipment	Manufacturer	Model	S/N	Cal Due.
Signal Generator	Agilent	E4438C	MY42082477	Mar. 31, 2012
Signal Generator	R & S	SMR40	100272	Jul. 15, 2011
Spectrum Analyzer	R & S	FSP40	100007	Jul. 15, 2011
Bluetooth Tester	TESOM	TC-3000B	3000B630018	Sep. 17, 2011
Directional Coupler	KRYTAR	152613	122661	May. 16, 2012
High Pass Filter	Wainwright	WHK3.0/18G-10SS	344	Sep. 29, 2011
DC power Supply	Agilent	U8002A	MY49030063	Jan. 05, 2012
Preamplifier	H.P.	8447F	2944A03909	Jul. 05, 2011
Preamplifier	R & S	8449B	3008A01932	Mar. 31, 2012
Test Receiver	R & S	ESU26	100109	Feb. 21, 2012
Bilog Antenna	SCHWARZBECK MESSELEKTRONIK	VULB9163	396	Jul. 22, 2011
Horn Antenna	SCHWARZBECK MESSELEKTRONIK	BBHA9120D	BBHA9170431	Mar. 17, 2012
Horn Antenna	R & S	HF 906	100326	Oct. 08, 2011
Antenna Master	EMCO	1050	N.C.R.	N.C.R.
Turn Table	Daeil EMC	DI-1500	N.C.R.	N.C.R.
Anechoic Chamber	SY Corporation	L x W x H (9.6 m x 6.4 m x 6.6 m)	N.C.R.	N.C.R.
Two-Line V-Network	R & S	ENV216	100190	Jan. 06, 2012
Test Receiver	R & S	ESHS10	863365/018	Apr. 27, 2012
Anechoic Chamber	SY Corporation	L x W x H (6.5 m x 3.5 m x 3.5 m)	N.C.R.	N.C.R.

The results shown in this test report refer only to the sample(s) tested unless otherwise stated. This test report cannot be reproduced, except in full, without prior written permission of the Company.

### 1.7. Summary of Test Results

The EUT has been tested according to the following specifications:

APPLIED STANDARD:FCC Part15, RSS-210,RSS-Gen			
Section in FCC 15	Section in RSS-210 RSS-Gen	Test Item	Result
15.205(a) 15.209 15.247(d)	A8.5	Transmitter Radiated Spurious Emissions Conducted Spurious Emission	Complied
15.109(a)	RSS-Gen 6	Receiver Radiated Spurious Emission	Complied
15.247(a)(1)	A8.1(1)	20 dB Bandwidth and 99% BW	Complied
15.247(b)(1)	A8.4(2)	Maximum Peak Output Power	Complied
15.247(a)(1)	A8.1(2)	Frequency Separation	Complied
15.247(b)(1)	A8.1(4)	Number of Hopping Frequency	Complied
15.247(a)(1)(iii)	A8.1(4)	Time of Occupancy (Dwell Time)	Complied
15.247(i) 1.1307(b)(1)	RSS-Gen 5.5/ RSS-102	Maximum Permissible Exposure (Exposure of Humans to RF Fields)	Complied

### 1.8 Test report revision

Revision	Report number	Description
0	F690501/RF-RTL004762	Initial

*The results shown in this test report refer only to the sample(s) tested unless otherwise stated. This test report cannot be reproduced, except in full, without prior written permission of the Company.*

## 2. Transmitter Radiated Spurious Emissions and Conducted Spurious Emission

### 2.1. Test Setup

#### 2.1.1. Transmitter Radiated Spurious Emissions

The diagram below shows the test setup that is utilized to make the measurements for emission from 30 MHz to 1 GHz Emissions.

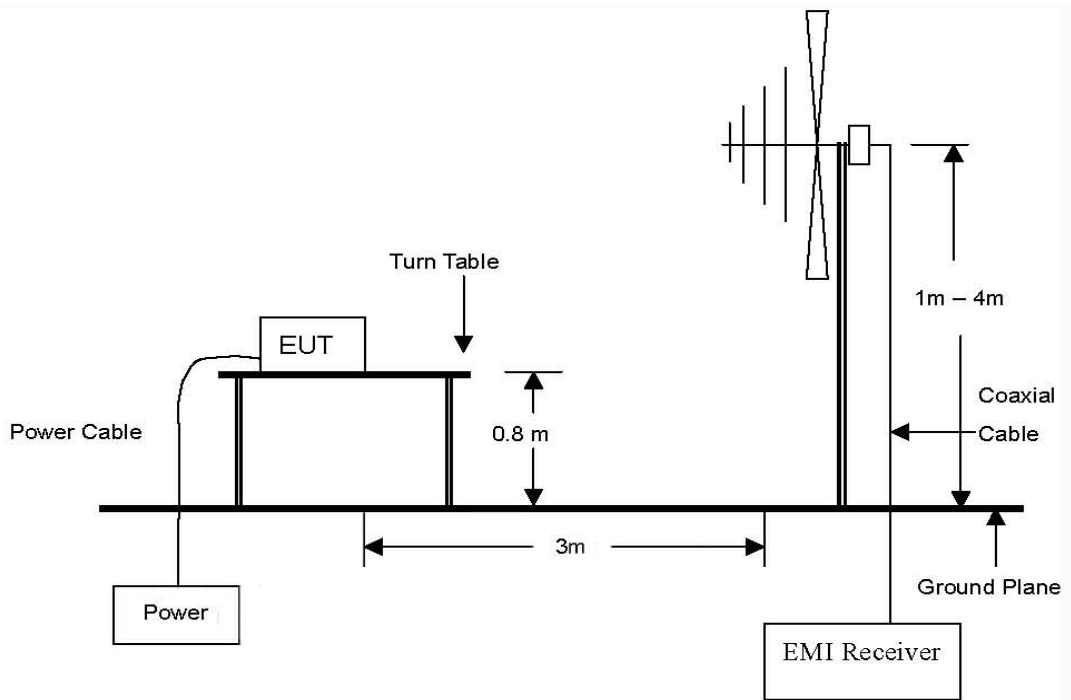

The diagram below shows the test setup that is utilized to make the measurements for emission from 1 GHz to 24 GHz Emissions.

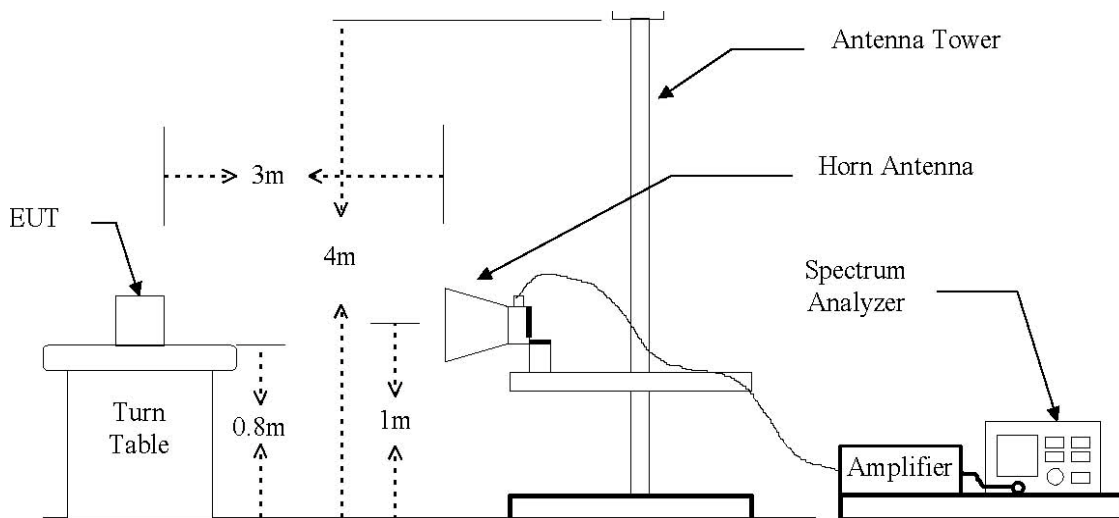

*The results shown in this test report refer only to the sample(s) tested unless otherwise stated. This test report cannot be reproduced, except in full, without prior written permission of the Company.*

### 2.1.2. Conducted Spurious Emissions

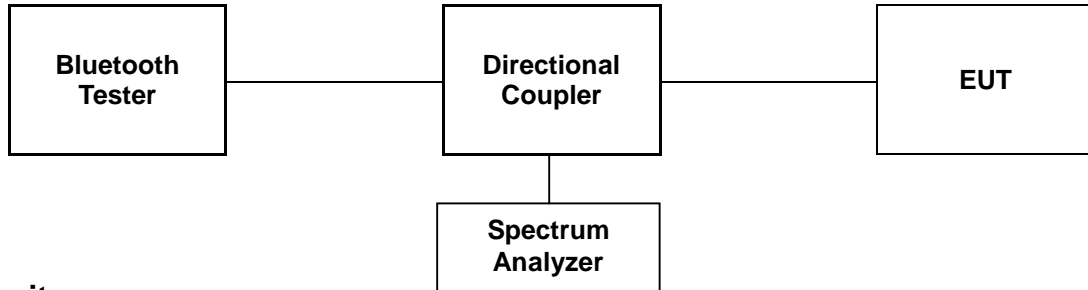

### 2.2. Limit

According to §15.247(d), in any 100 kHz bandwidth outside the frequency band in which the spread spectrum or digitally modulated intentional radiator is operating, the radio frequency power that is produced by the intentional radiator shall be at least 20 dB below that in the 100 kHz bandwidth within the band that contains the highest level of the desired power, based on either an RF conducted or a radiated measurement, provided the transmitter demonstrates compliance with the peak conducted power limits. If the transmitter complies with the conducted power limits based on the use of RMS averaging over a time interval, as permitted under paragraph(b)(3) of this section, the attenuation required under this paragraph shall be 30 dB instead of 20 dB. Attenuation below the general limits specified in section §15.209(a) is not required. In addition, radiated emission which in the restricted band, as define in section §15.205(a), must also comply the radiated emission limits specified in section §15.209(a) (see section §15.205(c))

According to § 15.209(a), Except as provided elsewhere in this Subpart, the emissions from an intentional radiator shall not exceed the field strength levels specified in the following table :

Frequency (MHz)	Distance (Meters)	Field Strength (dB µV/m)	Field Strength (µV/m)
30 - 88	3	40.0	100
88 – 216	3	43.5	150
216 – 960	3	46.0	200
Above 960	3	54.0	500

*The results shown in this test report refer only to the sample(s) tested unless otherwise stated. This test report cannot be reproduced, except in full, without prior written permission of the Company.*

## 2.3. Test Procedures

Radiated emissions from the EUT were measured according to the dictates of ANSI C63.4:2003

### 2.3.1. Test Procedures for Radiated Spurious Emissions

1. The EUT was placed on the top of a rotating table 0.8 meters above the ground at a 3 meter anechoic chamber test site. The table was rotated 360 degrees to determine the position of the highest radiation.
2. During performing radiated emission below 1 GHz, the EUT was set 3 meters away from the interference receiving antenna, which was mounted on the top of a variable-height antenna tower. During performing radiated emission above 1 GHz, the EUT was set 3 meter away from the interference-receiving antenna.
3. The antenna is a broadband antenna, and its height is varied from one meter to four meters above the ground to determine the maximum value of the field strength. Both horizontal and vertical polarizations of the antenna are set to make the measurement.
4. For each suspected emission, the EUT was arranged to its worst case and then the antenna was tuned to heights from 1 meter to 4 meters and the table was turned from 0 degrees to 360 degrees to find the maximum reading.
5. The test-receiver system was set to Peak Detect Function and Specified Bandwidth with Maximum Hold Mode.
6. If the emission level of the EUT in peak mode was 10 dB lower than the limit specified, then testing could be stopped and the peak values of the EUT would be reported. Otherwise the emissions that did not have 10 dB margin would be re-tested one by one using peak, quasi-peak or average method as specified and then reported in a data sheet.

#### NOTE ;

1. The resolution bandwidth and video bandwidth of test receiver/spectrum analyzer is 120 kHz for Peak detection (PK) and Quasi-peak detection (QP) at frequency below 1 GHz.
2. The resolution bandwidth and video bandwidth of test receiver/spectrum analyzer is 1 MHz for Peak detection and frequency above 1 GHz.
3. The resolution bandwidth of test receiver/spectrum analyzer is 1 MHz and the video bandwidth is 10 Hz for Average detection (AV) at frequency above 1 GHz.

### 2.3.2. Test Procedures for Conducted Spurious Emissions

1. The transmitter output was connected to the spectrum analyzer.
2. The bandwidth of the fundamental frequency was measured with the spectrum analyzer using RBW=100 kHz, VBW=100 kHz.

---

*The results shown in this test report refer only to the sample(s) tested unless otherwise stated. This test report cannot be reproduced, except in full, without prior written permission of the Company.*

## 2.4. Test Results

Ambient temperature : (23 ± 2) °C  
 Relative humidity : 47 % R.H.

### 2.4.1. Spurious Radiated Emission

The frequency spectrum from 30 MHz to 1 000 MHz was investigated. Emission levels are not reported much lower than the limits by over 30 dB. All reading values are peak values.

Radiated Emissions			Ant	Correction Factors		Total	FCC Limit	
Frequency (MHz)	Reading (dB $\mu$ V)	Detect Mode	Pol.	AF (dB/m)	AMP + CL (dB)	Actual (dB $\mu$ V/m)	Limit (dB $\mu$ V/m)	Margin (dB)
144.02	42.2	Peak	H	8.17	-26.33	24.04	43.5	19.46
192.03	43.3	Peak	H	9.53	-25.83	27.00	43.5	16.50
216.00	43.4	Peak	H	10.86	-25.62	28.64	43.5	14.86
240.01	50.9	Peak	H	12.17	-25.40	37.67	46.0	8.33
264.01	45.0	Peak	H	12.98	-25.24	32.74	46.0	12.26
Above 300.000	Not Detected	-	-	-	-	-	-	-

#### Remark:

1. All spurious emission at channels are almost the same below 1 GHz, so that middle channel was chosen at representative in final test.
2. Actual = Reading + AF + AMP + CL
3. The field strength of spurious emission was measured in three orthogonal EUT positions(x-axis, y-axis and z-axis). Worst case is x-axis.

*The results shown in this test report refer only to the sample(s) tested unless otherwise stated. This test report cannot be reproduced, except in full, without prior written permission of the Company.*

### 2.4.2. Spurious Radiated Emission

The frequency spectrum above 1 000 MHz was investigated. Emission levels are not reported much lower than the limits by over 30 dB.

#### Operating Mode: GFSK

##### A. Low Channel (2 402 MHz)

Radiated Emissions			Ant	Correction Factors		Total	FCC Limit	
Frequency (MHz)	Reading (dB $\mu$ V)	Detect Mode	Pol.	AF (dB/m)	CL (dB)	Actual (dB $\mu$ V/m)	Limit (dB $\mu$ V/m)	Margin (dB)
2 390.000	22.31	Peak	H	28.09	6.23	56.63	74.00	17.37
2 390.000	11.04	Average	H	28.09	6.23	45.36	54.00	8.64

Radiated Emissions			Ant	Correction Factors		Total	FCC Limit	
Frequency (MHz)	Reading (dB $\mu$ V)	Detect Mode	Pol.	AF (dB/m)	AMP+CL (dB)	Actual (dB $\mu$ V/m)	Limit (dB $\mu$ V/m)	Margin (dB)
4 803.944	45.16	Peak	H	32.59	-25.03	52.72	74.00	21.28
Above 4 900.000	Not Detected	-	-	-	-	-	-	-

##### B. Middle Channel (2 441 MHz)

Radiated Emissions			Ant	Correction Factors		Total	FCC Limit	
Frequency (MHz)	Reading (dB $\mu$ V)	Detect Mode	Pol.	AF (dB/m)	AMP+CL (dB)	Actual (dB $\mu$ V/m)	Limit (dB $\mu$ V/m)	Margin (dB)
4 881.919	44.45	Peak	H	32.90	-25.26	52.09	74.00	21.91
Above 4 900.000	Not Detected	-	-	-	-	-	-	-

The results shown in this test report refer only to the sample(s) tested unless otherwise stated. This test report cannot be reproduced, except in full, without prior written permission of the Company.

## C. High Channel (2 480 MHz)

Radiated Emissions			Ant	Correction Factors		Total	FCC Limit	
Frequency (MHz)	Reading (dB $\mu$ V)	Detect Mode	Pol.	AF (dB/m)	CL (dB)	Actual (dB $\mu$ V/m)	Limit (dB $\mu$ V/m)	Margin (dB)
2 483.500	24.25	Peak	H	28.09	6.36	58.70	74.00	17.37
2 483.500	14.92	Average	H	28.09	6.36	49.37	54.00	4.63

Radiated Emissions			Ant	Correction Factors		Total	FCC Limit	
Frequency (MHz)	Reading (dB $\mu$ V)	Detect Mode	Pol.	AF (dB/m)	AMP+CL (dB)	Actual (dB $\mu$ V/m)	Limit (dB $\mu$ V/m)	Margin (dB)
4 960.024	46.09	Peak	H	33.22	-24.64	54.67	74.00	19.33
4 960.024	31.92	Average	H	33.22	-24.64	40.50	54.00	13.50
Above 5 000.000	Not Detected	-	-	-	-	-	-	-

**Remarks :**

1. "\*" means the restricted band.
2. Measuring frequencies from 1 GHz to the 10<sup>th</sup> harmonic of highest fundamental Frequency.
3. Radiated emissions measured in frequency above 1 000 MHz were made with an instrument using peak/average detector mode.
4. Average test would be performed if the peak result were greater than the average limit.
5. Actual = Reading + AF + AMP + CL
6. The field strength of spurious emission was measured in three orthogonal EUT positions(x-axis, y-axis and z-axis). Worst case is x-axis.

The results shown in this test report refer only to the sample(s) tested unless otherwise stated. This test report cannot be reproduced, except in full, without prior written permission of the Company.

## 2.4.3. Spurious RF Conducted Emissions: Plot of Spurious RF Conducted Emission Operating Mode: GFSK

Low Channel

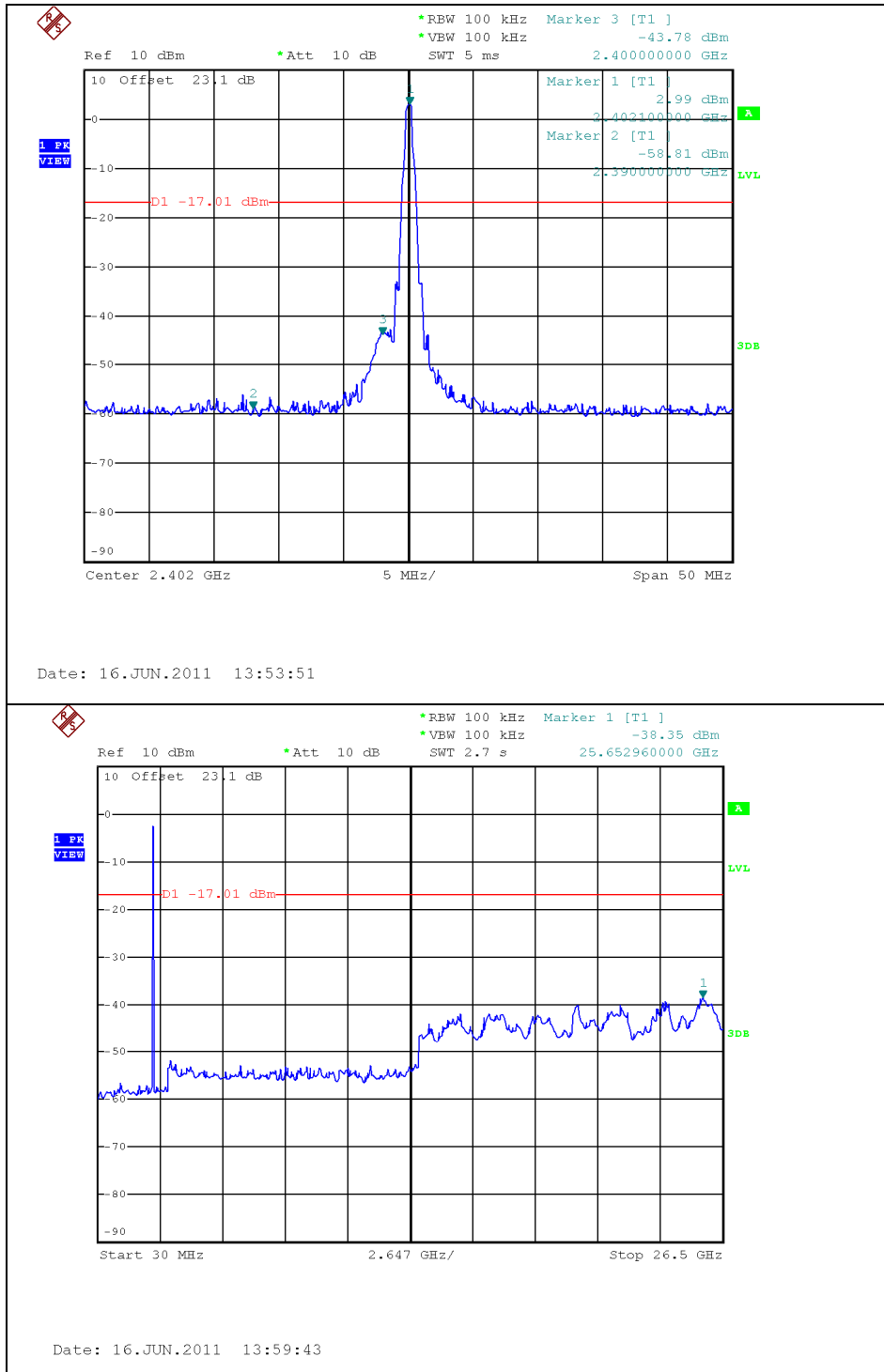

The results shown in this test report refer only to the sample(s) tested unless otherwise stated. This test report cannot be reproduced, except in full, without prior written permission of the Company.

Middle Channel

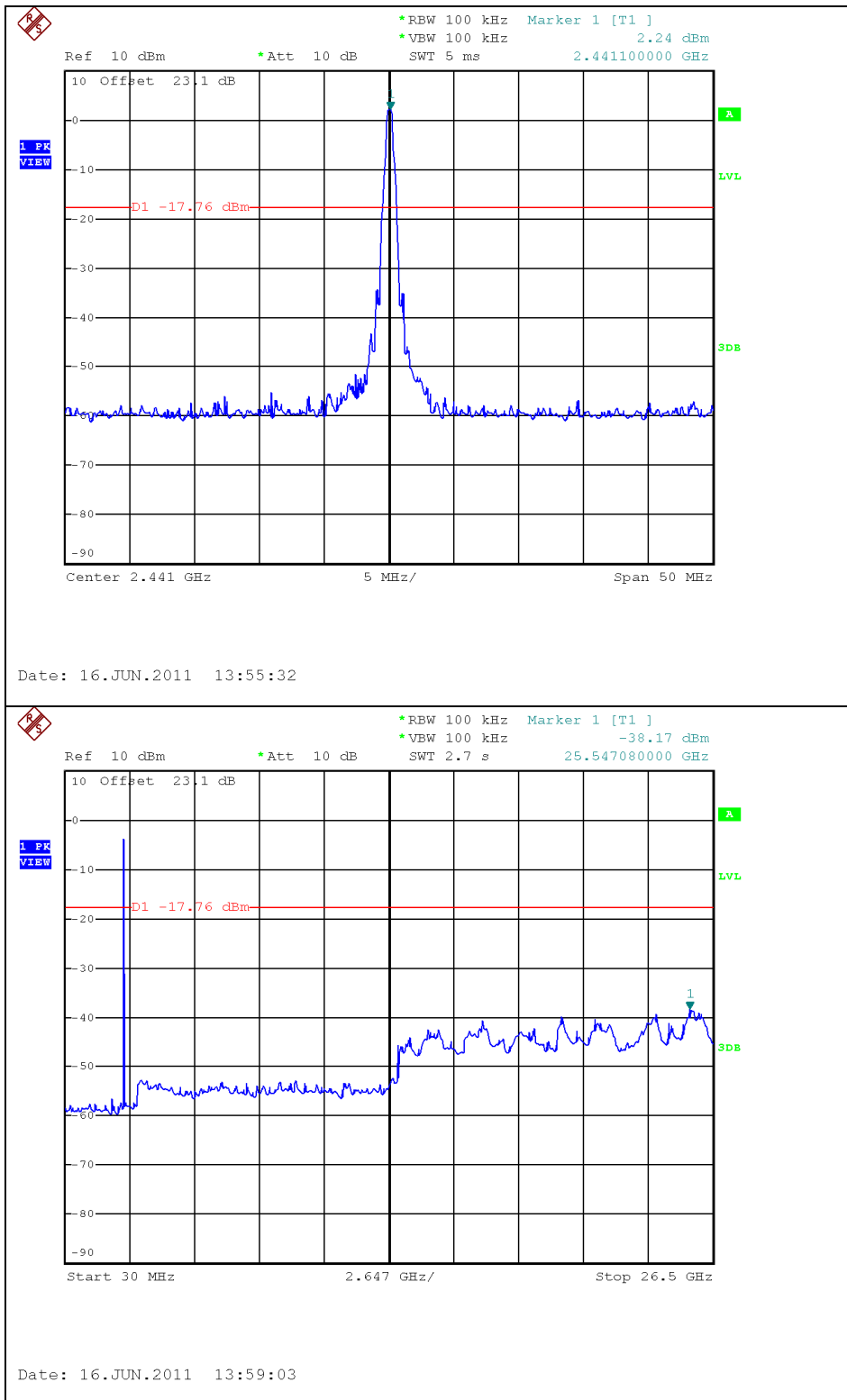

The results shown in this test report refer only to the sample(s) tested unless otherwise stated. This test report cannot be reproduced, except in full, without prior written permission of the Company.

High Channel

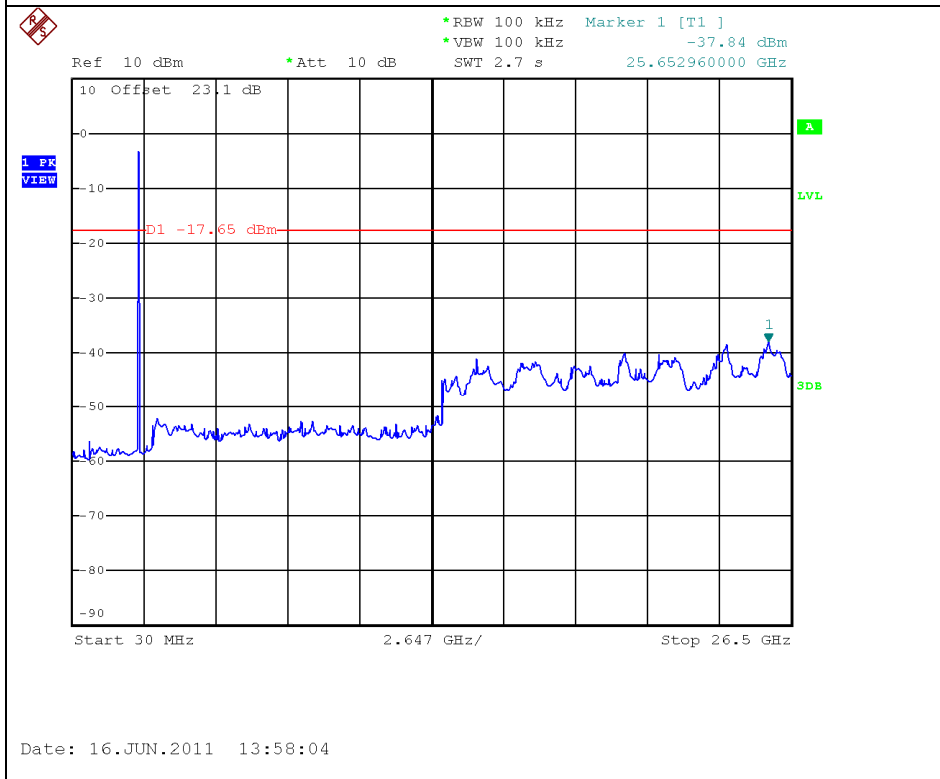
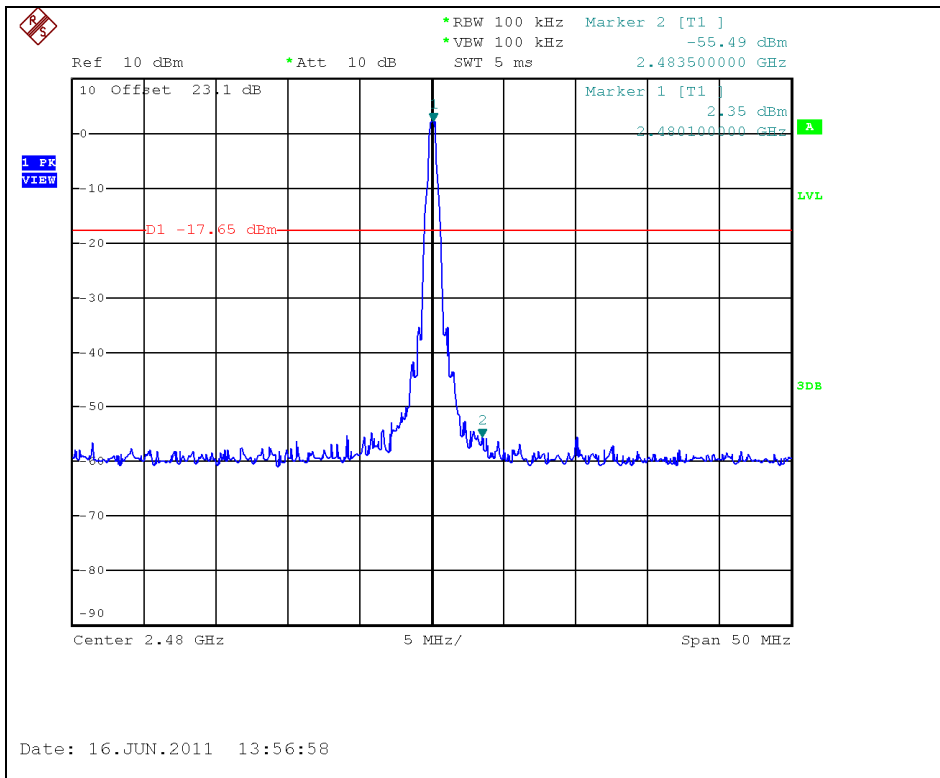

The results shown in this test report refer only to the sample(s) tested unless otherwise stated. This test report cannot be reproduced, except in full, without prior written permission of the Company.

Bandedge at Hopping

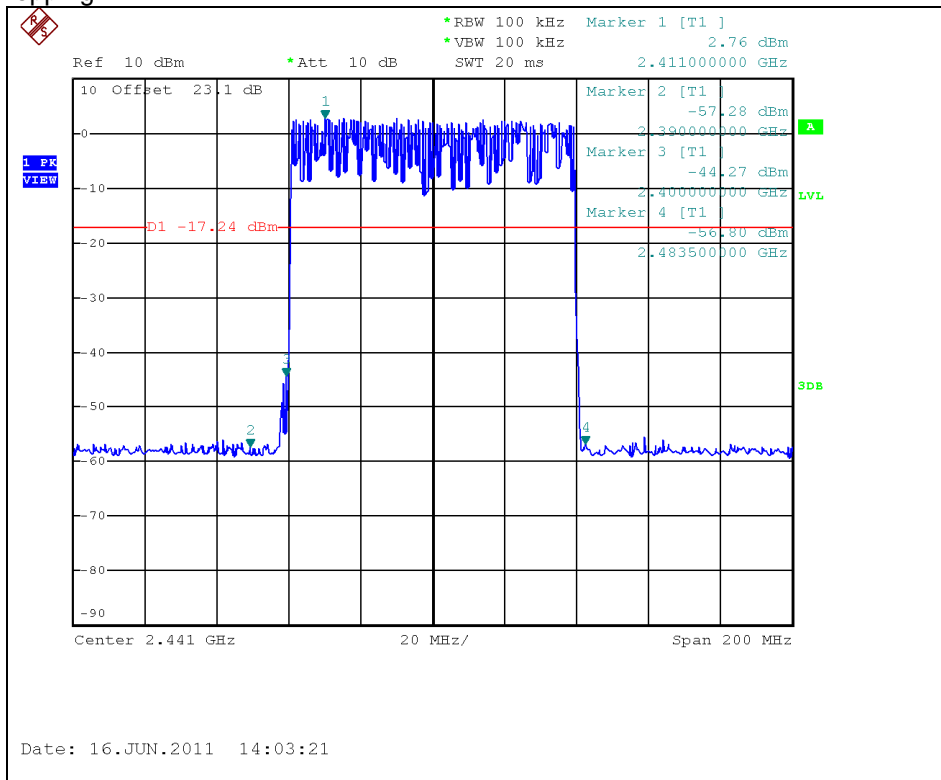

The results shown in this test report refer only to the sample(s) tested unless otherwise stated. This test report cannot be reproduced, except in full, without prior written permission of the Company.

### 3. Receiver Radiated spurious emissions

#### 3.1. Test setup - Same as clause 2.1.

##### 3.1.1. Receiver Radiated Spurious Emissions - Same as clause 2.1.1.

#### 3.2. Limit

According to §15.109(a), Except for Class A digital devices, the field strength of radiated emission from unintentional radiator at a distance of 3 m shall not exceed the following values:

Frequency (MHz)	Distance (Meters)	Radiated (dB $\mu$ V/m)	Radiated ( $\mu$ V/m)
30 - 88	3	40.0	100
88 – 216	3	43.5	150
216 – 960	3	46.0	200
Above 960	3	54.0	500

#### 3.3. Test Procedures - Same as clause 2.3.

Radiated emissions from the EUT were measured according to the dictates of ANSI C63.4:2003

##### 3.3.1. Test Procedures for Radiated Spurious Emissions- Same as clause 2.3.1.

*The results shown in this test report refer only to the sample(s) tested unless otherwise stated. This test report cannot be reproduced, except in full, without prior written permission of the Company.*

### 3.4. Test Results

Ambient temperature : (23 ± 2) °C  
 Relative humidity : 47 % R.H.

#### 3.4.1. Spurious Radiated Emission

The frequency spectrum from 30 MHz to 26.5 GHz was investigated. Emission levels are not reported much lower than the limits by over 30 dB. All reading values are peak values.

Radiated Emissions			Ant	Correction Factors		Total	FCC Limit	
Frequency (MHz)	Reading (dBμV)	Detect Mode	Pol.	AF (dB/m)	AMP + CL (dB)	Actual (dBμV/m)	Limit (dBμV/m)	Margin (dB)
144.02	36.8	Peak	H	8.17	-26.33	18.64	43.5	24.86
240.01	40.1	Peak	H	12.17	-25.40	26.87	46.0	19.13
Above 300.000	Not Detected	-	-	-	-	-	-	-

#### Remark:

1. All spurious emission at channels are almost the same from 30 MHz to 26.5 GHz, so that the middle channel was chosen at representative in final test.
2. Actual = Reading + AF + AMP + CL  
The field strength of spurious emission was measured in three orthogonal EUT positions(x-axis, y-axis and z-axis). Worst case is x-axis.
- 3.

*The results shown in this test report refer only to the sample(s) tested unless otherwise stated. This test report cannot be reproduced, except in full, without prior written permission of the Company.*

## 4. 20 dB Bandwidth Measurement and 99 % BW

### 4.1. Test Setup

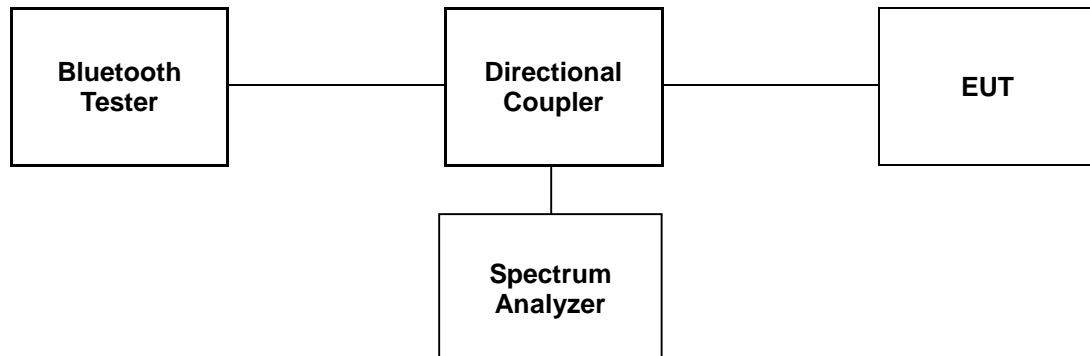

### 4.2. Limit

Limit: Not Applicable

### 4.3. Test Procedure

1. The 20 dB band width was measured with a spectrum analyzer connected to RF antenna connector(conducted measurement) while EUT was operating in transmit mode at the appropriate center frequency. The analyzer center frequency was set to the EUT carrier frequency, using the analyzer. Display Line and Marker Delta functions, the 20 dB band width of the emission was determined.
2. The bandwidth of the fundamental frequency was measured with the spectrum analyzer using RBW = 20 kHz, VBW = 20 kHz, Span = 5 MHz.

*The results shown in this test report refer only to the sample(s) tested unless otherwise stated. This test report cannot be reproduced, except in full, without prior written permission of the Company.*

#### 4.4. Test Results

Ambient temperature : (23 ± 2) °C  
 Relative humidity : 47 % R.H.

Operation Mode	Channel	Channel Frequency (MHz)	20 dB Bandwidth (MHz)	99 % Bandwidth (MHz)
GFSK	Low	2 402	0.85	0.97
	Middle	2 441	0.79	0.97
	High	2 480	0.80	0.96

*The results shown in this test report refer only to the sample(s) tested unless otherwise stated. This test report cannot be reproduced, except in full, without prior written permission of the Company.*

## 20 dB Bandwidth

### Operating Mode: GFSK

#### Low Channel

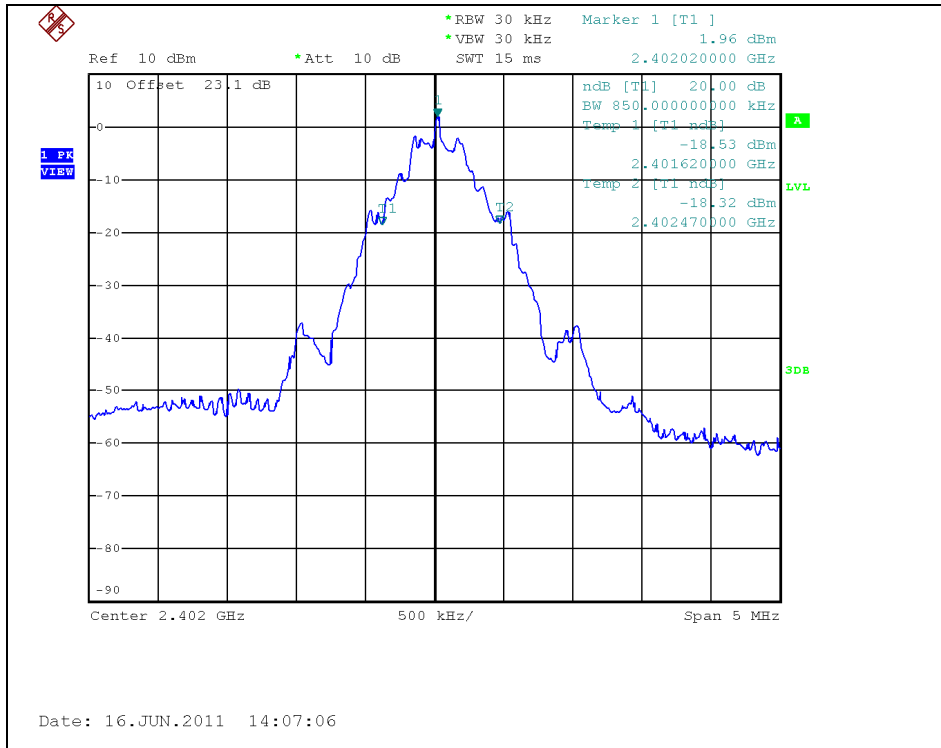

#### Middle Channel

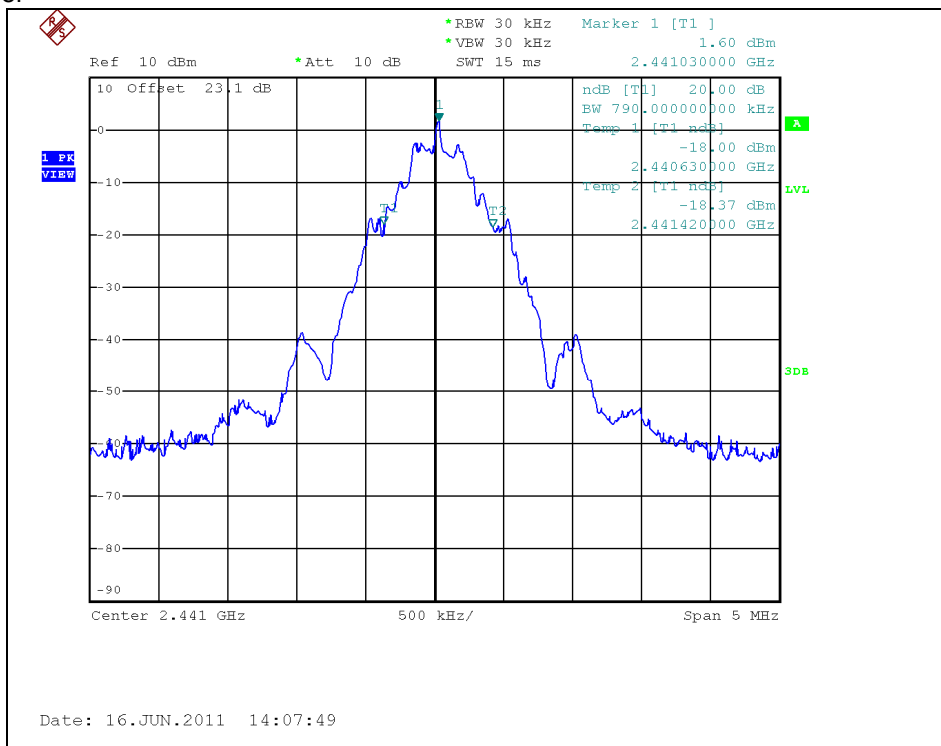

The results shown in this test report refer only to the sample(s) tested unless otherwise stated. This test report cannot be reproduced, except in full, without prior written permission of the Company.

High Channel

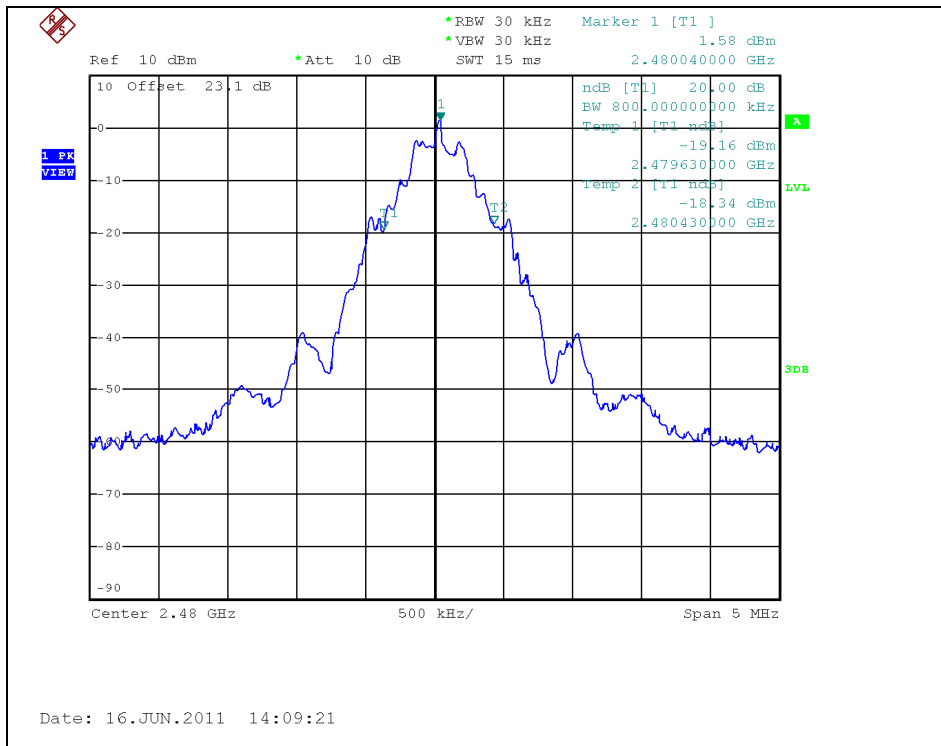

The results shown in this test report refer only to the sample(s) tested unless otherwise stated. This test report cannot be reproduced, except in full, without prior written permission of the Company.

**99 % Bandwidth**

**Operating Mode: GFSK**  
Low Channel

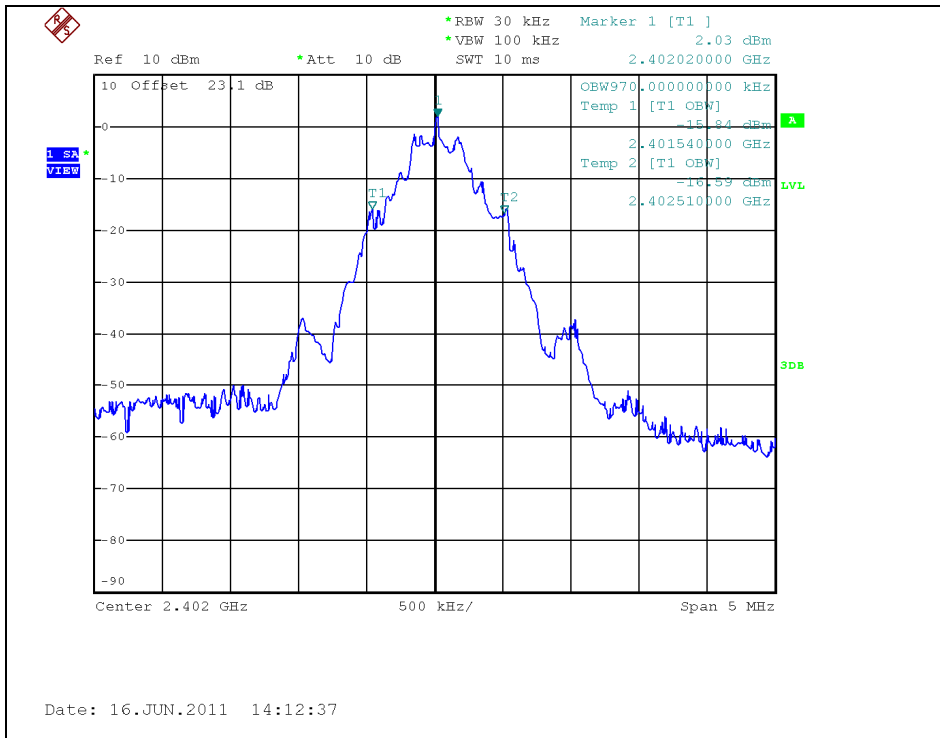

**Middle Channel**

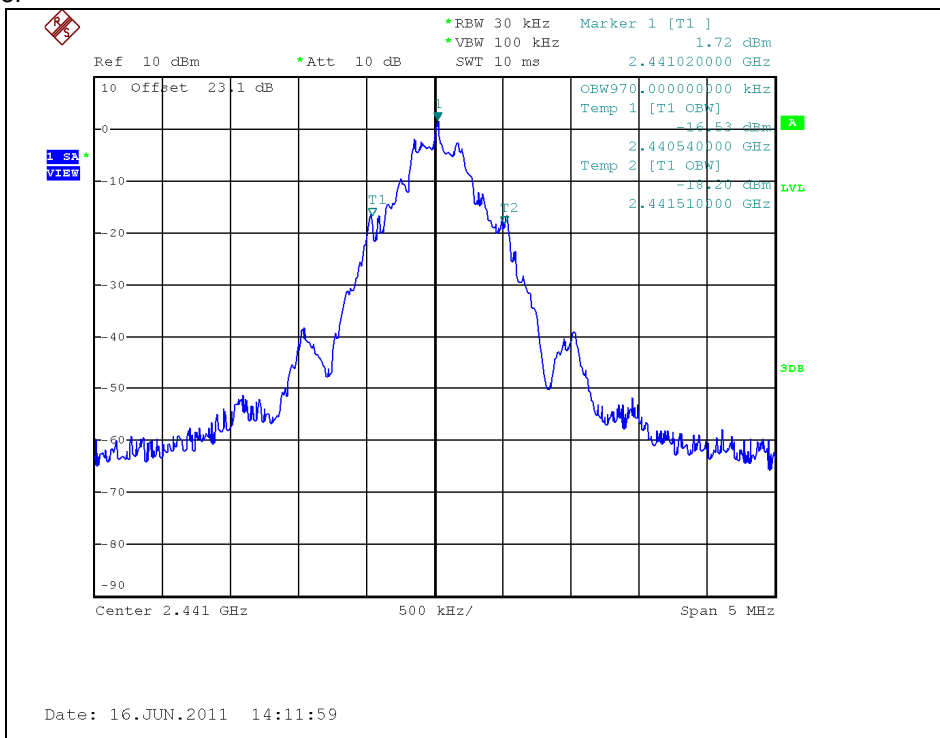

The results shown in this test report refer only to the sample(s) tested unless otherwise stated. This test report cannot be reproduced, except in full, without prior written permission of the Company.

High Channel

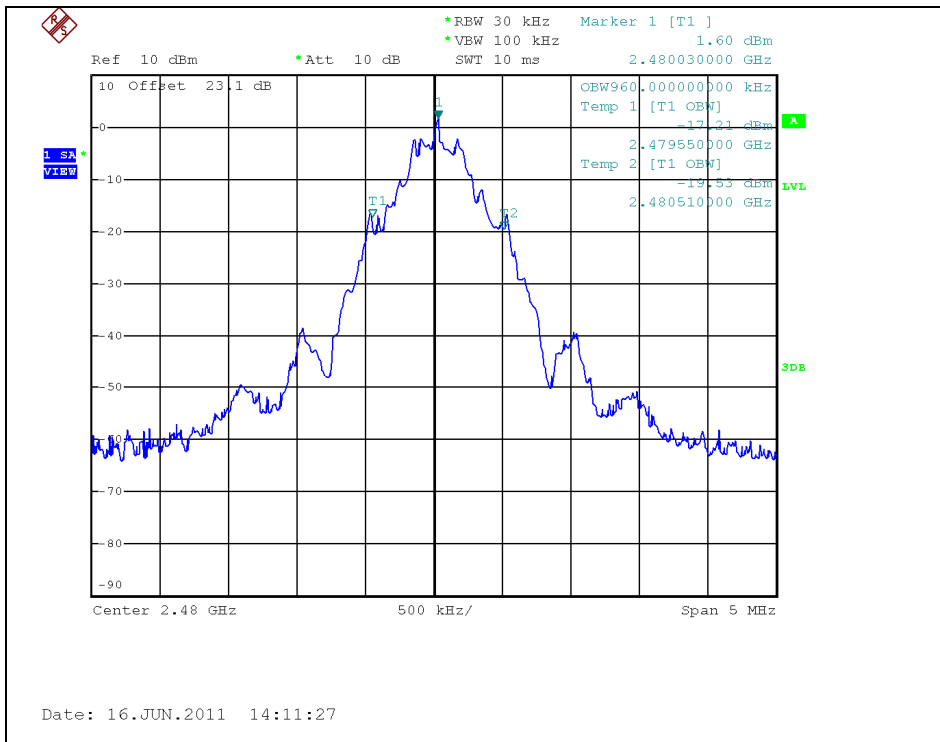

The results shown in this test report refer only to the sample(s) tested unless otherwise stated. This test report cannot be reproduced, except in full, without prior written permission of the Company.

## 5. Maximum Peak Output Power Measurement

### 5.1. Test Setup

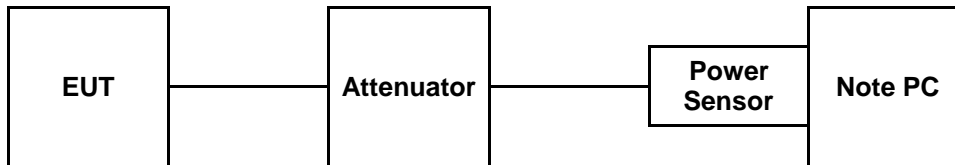

### 5.2. Limit

The maximum peak output power of the intentional radiator shall not exceed the following :

1. §15.247(a)(1), Frequency hopping systems shall have hopping channel carrier frequencies separated by a minimum of 25 kHz or the 20 dB bandwidth of the hopping channel, whichever is greater, provided the systems operate with an output power no greater than 125 mW.
2. §15.247(b)(1), For frequency hopping systems operating in the 2 400 – 2 483.5 MHz employing at least 75 non-overlapping hopping channels, and all frequency hopping systems in the 5 725 – 5 805 MHz band: 1 Watt.

### 5.3. Test Procedure

1. Place the EUT on the table and set it in the transmitting mode.
2. Remove the antenna from the EUT and then connect a low loss RF cable from the antenna port to the Power sensor.

---

*The results shown in this test report refer only to the sample(s) tested unless otherwise stated. This test report cannot be reproduced, except in full, without prior written permission of the Company.*

## 5.4. Test Results

Ambient temperature : (23 ± 2) °C

Relative humidity : 47 % R.H.

Operation Mode	Channel	Channel Frequency (MHz)	Attenuator + Cable offset (dB)	Peak Power Output (dB m)	Peak Power Limit (dB m)
GFSK	Low	2 402	21.30	3.63	30.00
	Middle	2 441	21.30	3.37	30.00
	High	2 480	21.30	3.28	30.00

*The results shown in this test report refer only to the sample(s) tested unless otherwise stated. This test report cannot be reproduced, except in full, without prior written permission of the Company.*

## 6. Hopping Channel Separation

### 6.1. Test Setup

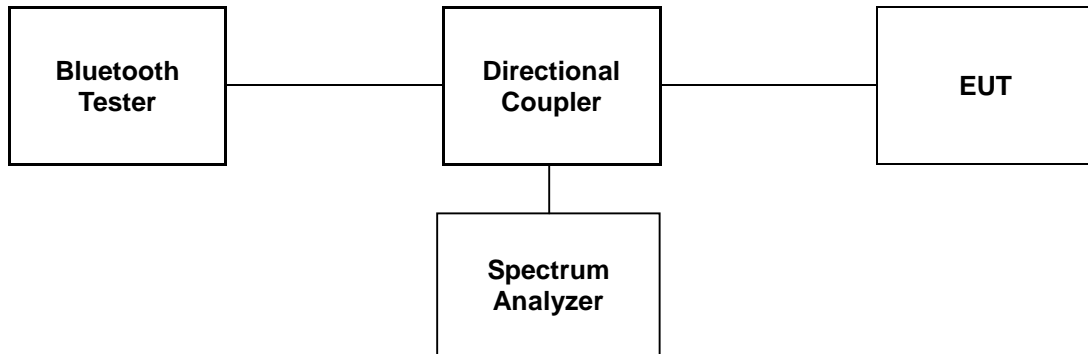

### 6.2. Limit

§15.247(a)(1) Frequency hopping system operating in 2 400 – 2 483.5 MHz. Band may have hopping channel carrier frequencies that are separated by 25 kHz or two-third of 20 dB bandwidth of the hopping channel, whichever is greater, provided the systems operate with an output power no greater than 125 mW.

### 6.3. Test Procedure

1. Check the calibration of the measuring instrument using either an internal calibrator or a known signal from an external generator.
2. Position the EUT as shown in test setup without connection to measurement instrument. Turn on the EUT and connect it to measurement instrument. Then set it to any one convenient frequency within its operating range.
3. By using the MaxHold function record the separation of adjacent channels.
4. Measure the frequency difference of these two adjacent channels by spectrum analyzer MARK function. And then plot the result on spectrum analyzer screen.
5. Repeat above procedures until all frequencies measured were complete.
6. Set center frequency of spectrum analyzer = middle of hopping channel.
7. Set the spectrum analyzer as RBW = 100 kHz, VBW = 100 kHz, Span = 5 MHz and Sweep = auto.

*The results shown in this test report refer only to the sample(s) tested unless otherwise stated. This test report cannot be reproduced, except in full, without prior written permission of the Company.*

## 6.4. Test Results

Ambient temperature : (23 ± 2) °C  
 Relative humidity : 47 % R.H.

Operation Mode	Channel (Middle)	Adjacent Hopping Channel Separation (kHz)	Two-third of 20 dB Bandwidth (kHz)	Minimum Bandwidth (kHz)
GFSK	2 441 MHz	1000	527	25

Note ;

20 dB bandwidth measurement, the measured channel separation should be greater than two-third of 20 dB bandwidth or Minimum bandwidth.

*The results shown in this test report refer only to the sample(s) tested unless otherwise stated. This test report cannot be reproduced, except in full, without prior written permission of the Company.*

**Operating Mode: GFSK**

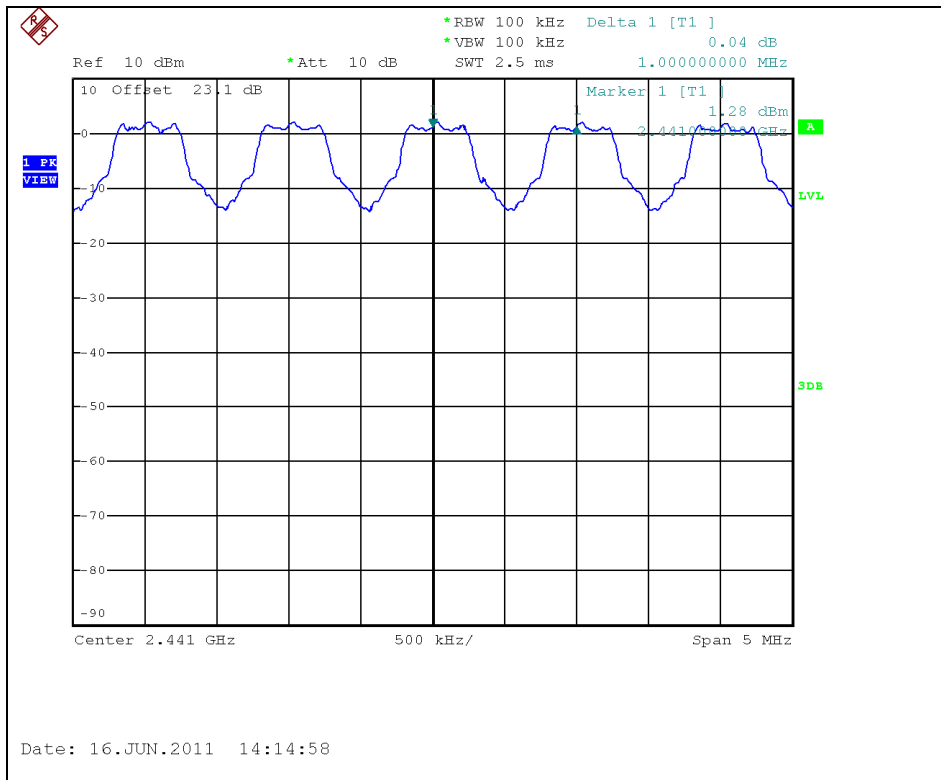

*The results shown in this test report refer only to the sample(s) tested unless otherwise stated. This test report cannot be reproduced, except in full, without prior written permission of the Company.*

## 7. Number of Hopping Frequency

### 7.1. Test Setup

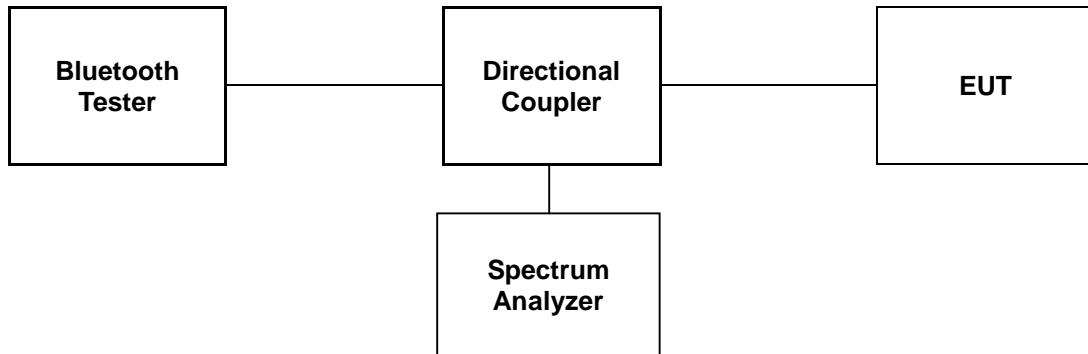

### 7.2. Limit

§15.247(b)(1), For frequency hopping systems operating in the 2 400 – 2 483.5 MHz employing at least 75 non-overlapping hopping channels, and all frequency hopping systems in the 5 725 – 5 805 MHz band: 1 Watt.

### 7.3. Test Procedure

1. Place the EUT on the table and set it in transmitting mode.
2. Remove the antenna from the EUT and then connect a low loss RF cable from the antenna the port to the Spectrum analyzer
3. Set spectrum analyzer Start = 2 400 MHz, Stop = 2 441.5 MHz, Sweep=auto and Start = 2 441.5 MHz, Stop = 2 483.5 MHz, Sweep = auto.
4. Set the spectrum analyzer as RBW, VBW = 100 kHz.
5. Max hold, view and count how many channel in the band.

*The results shown in this test report refer only to the sample(s) tested unless otherwise stated. This test report cannot be reproduced, except in full, without prior written permission of the Company.*

#### 7.4. Test Results

Ambient temperature : (23 ± 2) °C  
Relative humidity : 47 % R.H.

Operation Mode	Number of Hopping Frequency	Limit
GFSK	79	≥ 75

*The results shown in this test report refer only to the sample(s) tested unless otherwise stated. This test report cannot be reproduced, except in full, without prior written permission of the Company.*

**Operating Mode: GFSK**

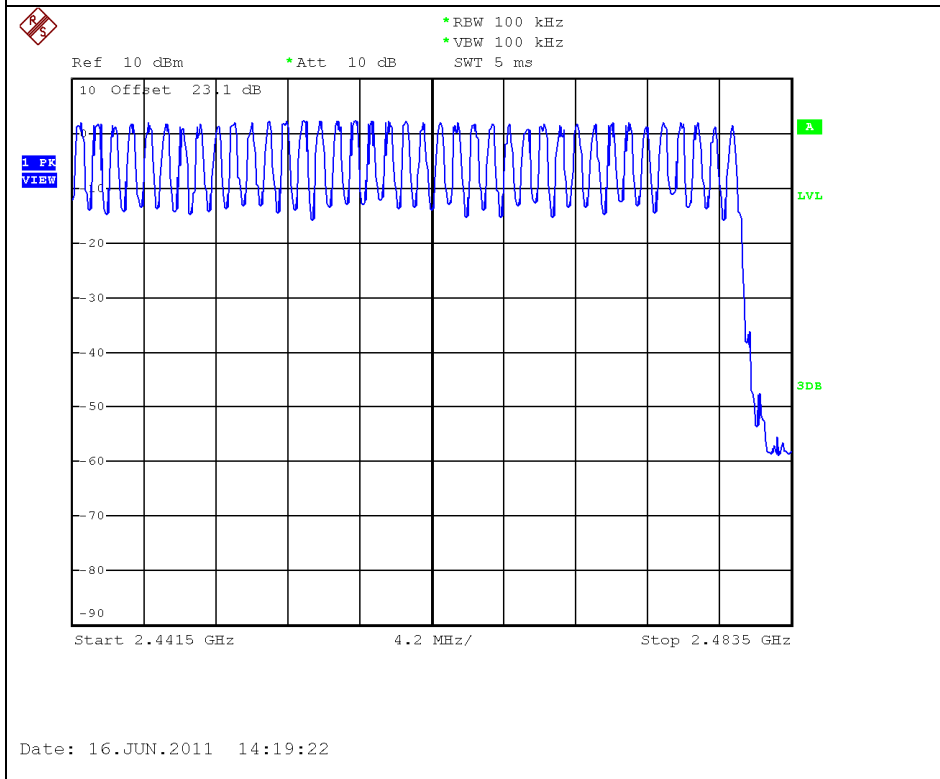
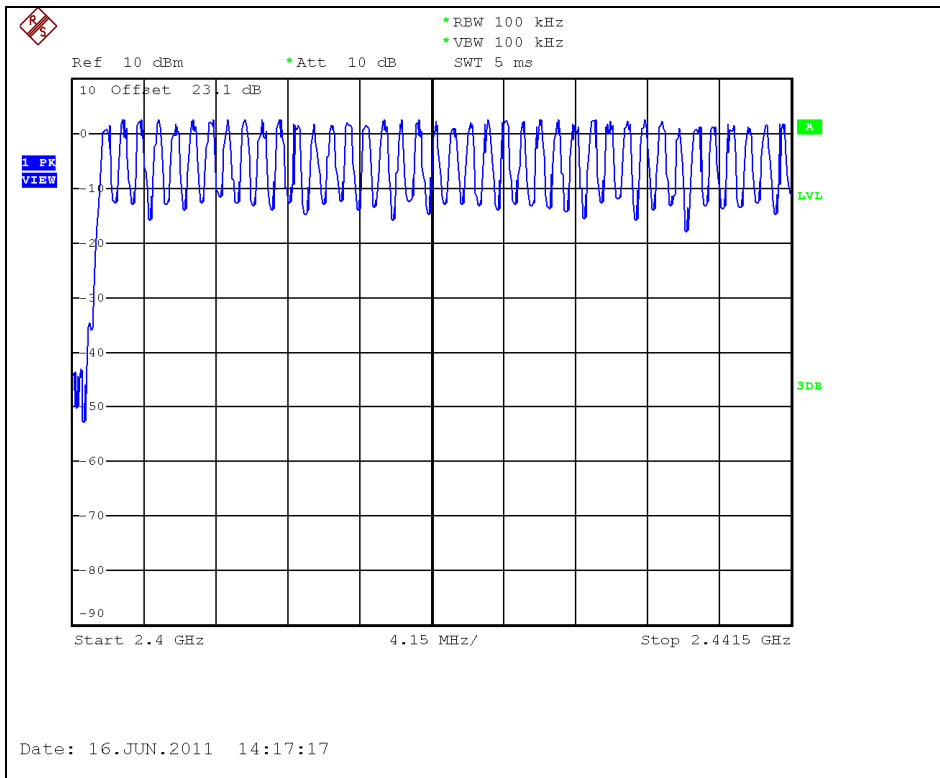

The results shown in this test report refer only to the sample(s) tested unless otherwise stated. This test report cannot be reproduced, except in full, without prior written permission of the Company.

## 8. Time Of Occupancy (Dwell Time)

### 8.1. Test Set up

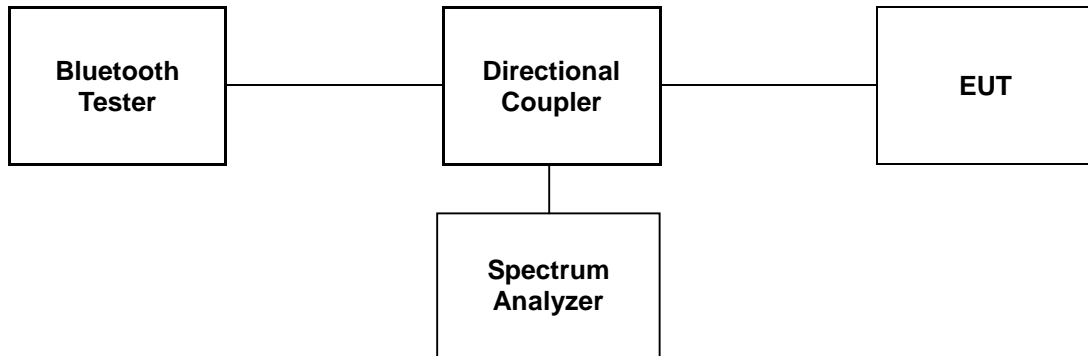

### 8.2. Limit

§15.247(a)(1)(iii) For frequency hopping system operating in the 2 400 – 2 483.5 MHz band, the average time of occupancy on any frequency shall not be greater than 0.4 second within a 31.6 second period.

A period time = 0.4(s) \* 79 = 31.6(s)

### 8.3. Test Procedure

1. Check the calibration of the measuring instrument using either an internal calibrator or a known signal from an external generator.
2. Position the EUT as shown in test setup without connection to measurement instrument. Turn on the EUT and connect its antenna terminal to measurement instrument via a low loss cable.
3. Adjust the center frequency of spectrum analyzer on any frequency be measured and set spectrum analyzer to zero span mode. And then, set RBW and VBW of spectrum analyzer to proper value.
4. Measure the time duration of one transmission on the measured frequency. And then plot the result with time difference of this time duration.
5. Repeat above procedures until all frequencies measured were complete.
6. The Bluetooth has 3 type of payload, DH1, DH3, DH5. The hopping rate is 1 600 per second.

*The results shown in this test report refer only to the sample(s) tested unless otherwise stated. This test report cannot be reproduced, except in full, without prior written permission of the Company.*

### 8.4. Test Results

Ambient temperature : (23 ± 2) °C  
 Relative humidity : 47 % R.H.

Time of occupancy on the TX channel in 31.6sec  
 = time domain slot length × (hop rate ÷ number of hop per channel) × 31.6

#### 8.4.1. Packet Type: DH1

Operation Mode	Frequency	Dwell Time (ms)	Time of occupancy on the Tx Channel in 31.6 sec (ms)	Limit for time of occupancy on the Tx Channel in 31.6 sec (ms)
GFSK	2 441 MHz	0.42	134.4	400

$2\,441\text{ MHz} : 0.42\text{ (ms)} \times [(1\,600 \div 2) \div 79] \times 31.6\text{ (s)} = 134.4\text{ (ms)}$

#### Operating Mode: GFSK

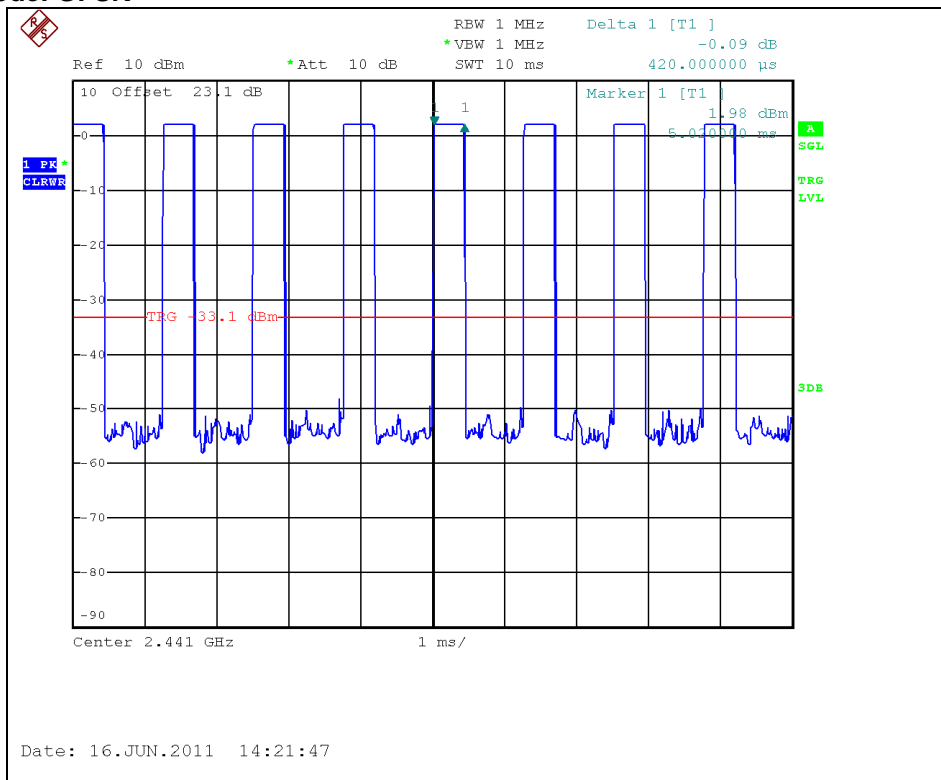

The results shown in this test report refer only to the sample(s) tested unless otherwise stated. This test report cannot be reproduced, except in full, without prior written permission of the Company.

### 8.4.2. Packet Type: DH3

Operation Mode	Frequency	Dwell Time (ms)	Time of occupancy on the Tx Channel in 31.6 sec (ms)	Limit for time of occupancy on the Tx Channel in 31.6 sec (ms)
GFSK	2 441 MHz	1.68	268.8	400

$$2\,441\text{ MHz} : 1.68\text{ (ms)} \times [(1\,600 \div 4) \div 79] \times 31.6\text{(s)} = 268.8\text{ (ms)}$$

#### Operating Mode: GFSK

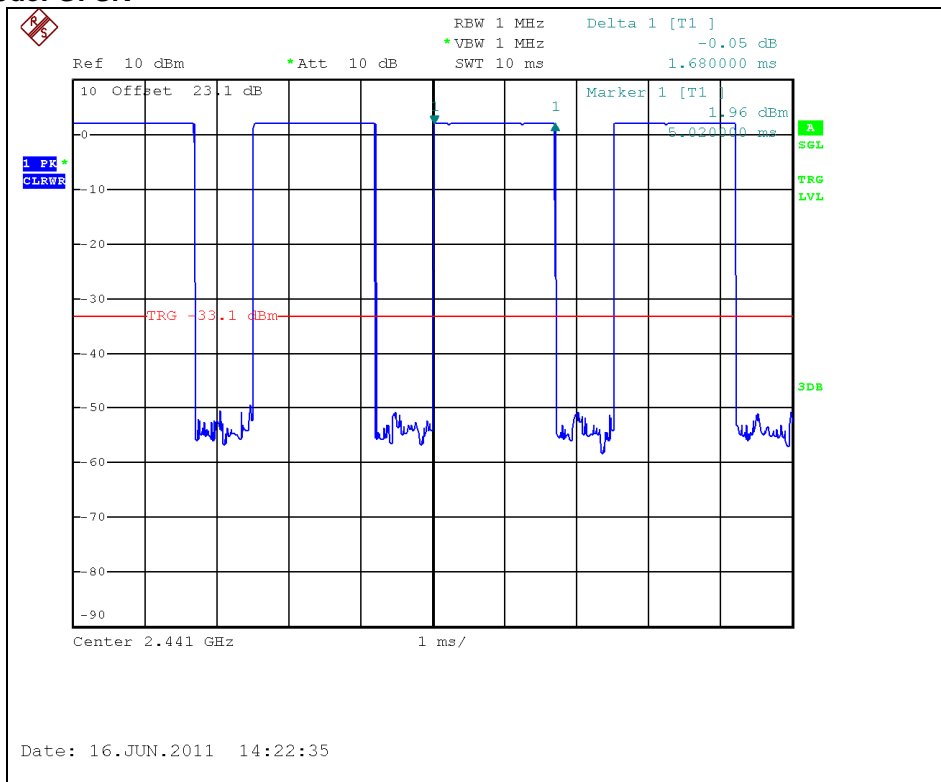

The results shown in this test report refer only to the sample(s) tested unless otherwise stated. This test report cannot be reproduced, except in full, without prior written permission of the Company.

### 8.4.3. Packet Type: DH5

Operation Mode	Frequency	Dwell Time (ms)	Time of occupancy on the Tx Channel in 31.6 sec (ms)	Limit for time of occupancy on the Tx Channel in 31.6 sec (ms)
GFSK	2 441 MHz	2.94	313.6	400

$$2\,441\text{ MHz} : 2.94\text{ (ms)} \times [(1\,600 \div 6) \div 79] \times 31.6\text{(s)} = 313.6\text{ (ms)}$$

#### Operating Mode: GFSK

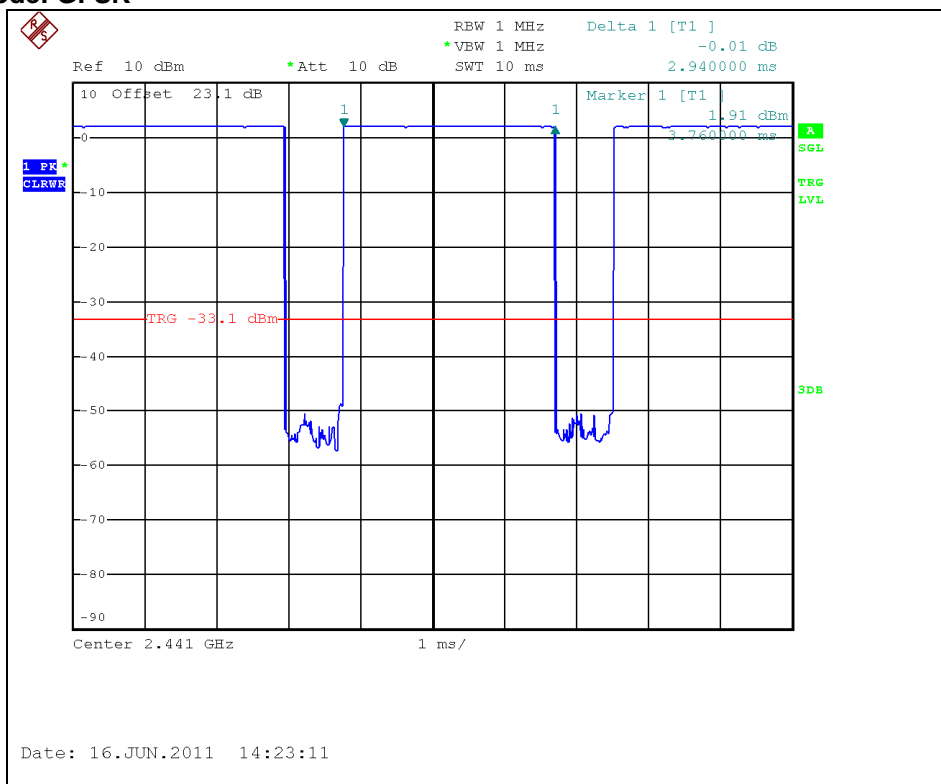

The results shown in this test report refer only to the sample(s) tested unless otherwise stated. This test report cannot be reproduced, except in full, without prior written permission of the Company.

---

## 9. Antenna Requirement

### 9.1. Standard Applicable

For intentional device, according to FCC 47 CFR Section §15.203, an intentional radiator shall be designed to ensure that no antenna other than that furnished by the responsible party shall be used with the device. And according to FCC 47 CFR Section §15.247 (b) if transmitting antennas of directional gain greater than 6 dB i are used, the power shall be reduced by the amount in dB that the gain of the antenna exceeds 6 dB i.

### 9.2. Antenna Connected Construction

Antenna used in this product is Integral type (Chip Antenna ) gain of 1.99 dB i.

---

*The results shown in this test report refer only to the sample(s) tested unless otherwise stated. This test report cannot be reproduced, except in full, without prior written permission of the Company.*

## 10. RF Exposure Evaluation

### 10.1 Environmental evaluation and exposure limit according to FCC CFR 47 part 1, 1.1307(b), 1.1310

According to FCC 1.1310 : The criteria listed in the following table shall be used to evaluate the environment impact of human exposure to radio frequency (RF) radiation as specified in §1.1307(b)

#### LIMITS FOR MAXIMUM PERMISSIBLE EXPOSURE (MPE)

Frequency Range (MHz)	Electric Field Strength(V/m)	Magnetic Field Strength (A/m)	Power Density (mW/cm <sup>2</sup> )	Average Time
(A) Limits for Occupational /Control Exposures				
300 – 1 500	--	--	F/300	6
1 500 – 100 000	--	--	5	6
(B) Limits for General Population/Uncontrol Exposures				
300 – 1 500	--	--	F/1500	6
<b><u>1 500 – 100 000</u></b>	--	--	<b><u>1</u></b>	<b><u>30</u></b>

#### 10.1.1. Friis transmission formula: $Pd = (Pout \cdot G) / (4 \cdot \pi \cdot R^2)$

Where Pd = power density in mW/cm<sup>2</sup>

Pout = output power to antenna in mW

G = gain of antenna in linear scale

Pi = 3.1416

R = distance between observation point and center of the radiator in cm

Pd the limit of MPE, 1 mW/cm<sup>2</sup>. If we know the maximum gain of the antenna and the total power input to the antenna, through the calculation, we will know the distance where the MPE limit is reached.

*The results shown in this test report refer only to the sample(s) tested unless otherwise stated. This test report cannot be reproduced, except in full, without prior written permission of the Company.*

### 10.1.2. Test Result of RF Exposure Evaluation

Test Item : RF Exposure Evaluation Data

Test Mode : Normal Operation

### 10.1.3. Output Power into Antenna & RF Exposure Evaluation Distance

FHSS : GFSK

Channel	Channel Frequency (MHz)	Output Average Power to Antenna (dB m)	Antenna Gain (dB i)	Power Density at 20 cm (mW/cm <sup>2</sup> )	LIMITS (mW/cm <sup>2</sup> )
Low	2 402	-2.59	1.99	0.000 17	1
Middle	2 441	-3.31	1.99	0.000 15	1
High	2 480	-3.46	1.99	0.000 14	1

Note :

1. The power density Pd (5th column) at a distance of 20 cm calculated from the friis transmission formula is far below the limit of 1 mW/cm<sup>2</sup> .

*The results shown in this test report refer only to the sample(s) tested unless otherwise stated. This test report cannot be reproduced, except in full, without prior written permission of the Company.*