

TEST REPORT

FCC Test for AT1K01-A00

APPLICANT

SAMSUNG Electronics Co., Ltd.

REPORT NO.

HCT-RF-1907-FC011-R1

DATE OF ISSUE

06 August 2019

HCT Co., Ltd.

74, Seoicheon-ro 578beon-gil, Majang-myeon, Icheon-si, Gyeonggi-do, 17383 KOREA
Tel. +82 31 634 6300 F ax. +82 31 645 6401



HCT Co., Ltd.

74, Seoicheon-ro 578beon-gil, Majang-myeon, Icheon-si, Gyeonggi-do, 17383 KOREA
Tel. +82 31 634 6300 Fax. +82 31 645 6401

**TEST
REPORT**
FCC Test for
AT1K01-A00

REPORT NO.
HCT-RF-1907-FC011-R1

DATE OF ISSUE
06 August 2019

FCC ID
A3LAT1K01-A00

Applicant	SAMSUNG Electronics Co., Ltd. 129, Samsung-ro, Yeongtong-gu, Suwon-si, Gyeonggi-do, 16677, Rep. of Korea
Product Name	AU(AT1K01)
Model Name	AT1K01-A00
Date of Test	July 11, 2019 ~ July 30, 2019
Test Standard Used	CFR 47 Part 2, Part 30

The result shown in this test report refer only to the sample(s) tested unless otherwise stated.
This test results were applied only to the test methods required by the standard.

Tested by
Kwang Il Yoon

(signature)

Technical Manager
Jong Seok Lee

(signature)

HCT CO., LTD.

Soo Chan Lee
SooChan Lee / CEO

REVISION HISTORY

The revision history for this test report is shown in table.

Revision No.	Date of Issue	Description
0	30 July 2019	Initial Release
1	06 August 2019	We corrected a few typos. We added a note on page 9.

The measurements shown in this report were made in accordance with the procedures indicated, and the emissions from this equipment were found to be within the limits applicable. I assume full responsibility for the accuracy and completeness of these measurements, and for the qualifications of all persons taking them. It is further stated that upon the basis of the measurements made, the equipment tested is capable of operation in accordance with the requirements of the FCC Rules under normal use and maintenance.

CONTENTS

1. GENERAL INFORMATION	5
1.1. APPLICANT INFORMATION	5
1.2. PRODUCT INFORMATION	5
1.3. TEST INFORMATION	6
2. FACILITIES AND ACCREDITATIONS	7
2.1. FACILITIES	7
2.2. EQUIPMENT	7
3. TEST SPECIFICATIONS	8
3.1. STANDARDS	8
3.2. ADDITIONAL DESCRIPTIONS ABOUT TEST	9
3.3. MAXIMUM MEASUREMENT UNCERTAINTY	11
3.4. STANDARDS ENVIRONMENTAL TEST CONDITIONS	11
3.5. TEST DIAGRAMS	12
4. TEST EQUIPMENTS	14
5. TEST RESULT	15
5.1. OCCUPIED BANDWIDTH	15
5.2. EIRP DENSITY	30
5.3. CONDUCTED OUTPUT POWER	73
5.4. BAND EDGE	114
5.5. RADIATED SPURIOUS EMISSIONS	217
5.6. FREQUENCY STABILTY	266
6. Annex A_Test Equipment CERTIFIED DOCUMENTS	269
7. Annex B_EUT AND TEST SETUP PHOTO	270

1. GENERAL INFORMATION

1.1. APPLICANT INFORMATION

Company Name	Samsung Electronics Co., Ltd.
Company Address	129, Samsung-ro, Yeongtong-gu, Suwon-si, Gyeonggi-do, 16677, Rep. of Korea

1.2. PRODUCT INFORMATION

EUT Type	AU(AT1K01)																	
Equipment Class	5GB-Part 30 Fixed Transmitter																	
Power Supply	AC (100 ~ 240) V																	
Output Power	For 1 Path: <table border="1" data-bbox="584 1095 1453 1276"> <thead> <tr> <th>Mode</th> <th>dBm</th> <th>W</th> </tr> </thead> <tbody> <tr> <td>1CC</td> <td>48</td> <td>63.1</td> </tr> <tr> <td>2CC</td> <td>51</td> <td>125.9</td> </tr> <tr> <td>3CC</td> <td>52.77</td> <td>189.2</td> </tr> <tr> <td>4~8CC</td> <td>54</td> <td>251.2</td> </tr> </tbody> </table>			Mode	dBm	W	1CC	48	63.1	2CC	51	125.9	3CC	52.77	189.2	4~8CC	54	251.2
Mode	dBm	W																
1CC	48	63.1																
2CC	51	125.9																
3CC	52.77	189.2																
4~8CC	54	251.2																
	Total (4 Path) MAX: 60 dBm (1 000 W)																	
Frequency Range	27 500 MHz ~ 28 350 MHz																	
Emission Designator	<table border="1" data-bbox="584 1447 1453 1563"> <thead> <tr> <th>Mode</th> <th>QPSK (G7D)</th> <th>16QAM / 64QAM (W7D)</th> </tr> </thead> <tbody> <tr> <td>1CC</td> <td>97M9G7D</td> <td>98M0W7D</td> </tr> <tr> <td>8CC</td> <td>788MG7D</td> <td>788MW7D</td> </tr> </tbody> </table>	Mode	QPSK (G7D)	16QAM / 64QAM (W7D)	1CC	97M9G7D	98M0W7D	8CC	788MG7D	788MW7D								
Mode	QPSK (G7D)	16QAM / 64QAM (W7D)																
1CC	97M9G7D	98M0W7D																
8CC	788MG7D	788MW7D																
Channel Bandwidths	1CC: 100 MHz ~ 8CC: 800 MHz																	
Modulation Type	QPSK, 16QAM, 64QAM																	

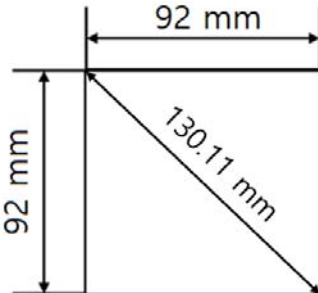
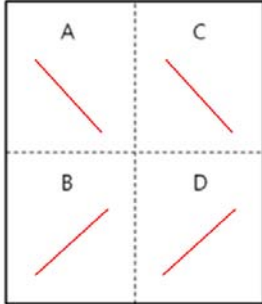
Antenna Specification	<p>Maximum Gain: 28.533 dBi</p> <p>Size: Array:</p> <div style="display: flex; justify-content: space-around; align-items: center;">   </div>
-----------------------	--

1.3. TEST INFORMATION

FCC Rule Parts	CFR 47 Part 2, Part 30
Measurement standards	ANSI C63.26-2015, KDB 971168 D01 v03r01, KDB 662911 D01 v02r01, KDB 662911 D02 v01, KDB 842590 D01 v01
Place of Test	HCT CO., LTD. 74, Seoicheon-ro 578beon-gil, Majang-myeon, Icheon-si, Gyeonggi-do, 17383, Rep. of KOREA

2. FACILITIES AND ACCREDITATIONS

2.1. FACILITIES

The SAC(Semi-Anechoic Chamber) and conducted measurement facility used to collect the radiated data are located at the 74, Seoicheon-ro 578beon-gil, Majang-myeon, Icheon-si, Gyeonggi-do, 17383, Rep. of KOREA. The site is constructed in conformance with the requirements of ANSI C63.4 (Version: 2014) and CISPR Publication 22. Detailed description of test facility was submitted to the Commission and accepted dated April 02, 2018 (Registration Number: KR0032).

2.2. EQUIPMENT

Radiated emissions are measured with one or more of the following types of Linearly polarized antennas: tuned dipole, bi-conical, log periodic, bi-log, and/or ridged waveguide, horn. Spectrum analyzers with pre-selectors and quasi-peak detectors are used to perform radiated measurements.

Calibrated wideband preamplifiers, coaxial cables, and coaxial attenuators are also used for making measurements.

All receiving equipment conforms to CISPR Publication 16-1, "Radio Interference Measuring Apparatus and Measurement Methods."

3. TEST SPECIFICATIONS

3.1. STANDARDS

The following tests were conducted on a sample of the equipment for the purpose of demonstrating compliance with FCC Part 2, Part 30

Description	Reference	Results
Occupied Bandwidth	§ 2.1049	Compliant
EIRP Density	§ 30.202	Compliant
Conducted Output Power	§ 2.1046	Compliant
Band Edge	§ 2.1051, § 30.203	Compliant
Radiated Spurious Emissions	§ 2.1051, § 30.203	Compliant
Frequency Stability	§ 2.1055	Compliant

3.2. ADDITIONAL DESCRIPTIONS ABOUT TEST

- All tests is performed by radiated measurement and applied below conditions.

: Used measurement distance with far field of test such as EIRP, OBW and Band edge are as follow.

$$\text{Wavelength} = \text{Speed of light} / \text{Measurement frequency} = 30 / 2835 = 0.01058$$

$$(2 \times (\text{Max antenna length of EUT})^2) / \text{Wavelength} = (2 \times (0.1301)^2) / 0.01058 = \mathbf{3.199 \text{ m}}$$

So, measurement distance is 3.5 m.

: Spurious emissions measurement distance is shown in table below(Reference : Measurement Antenna Dimension).

Frequency Range (GHz)	Wavelength (cm)	Far Field Distance (m)	Measurement Distance(m)
18 ~ 40	0.75	2.46	3.75
40 ~ 60	0.50	1.354	3.75
60 ~90	0.33	0.856	3.75
90 ~ 100	0.30	0.409	3.75

: Radiated test is performed on various angle of antenna and following location is worst test case.

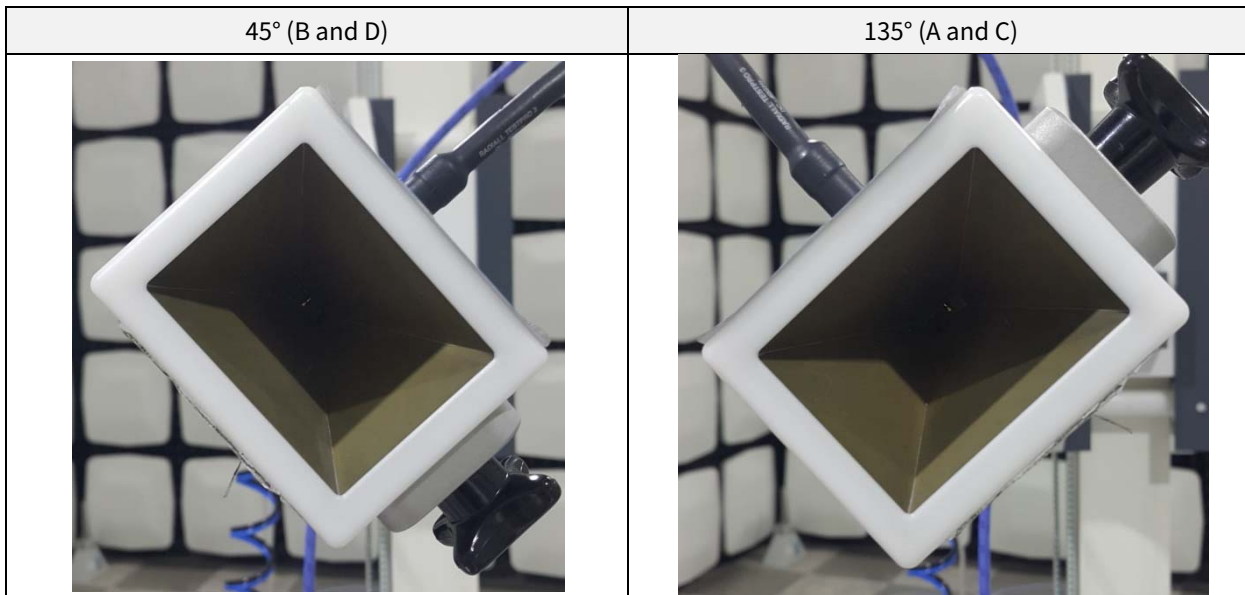

- CC means component carriers and EUT support 1 cc ~ 8 cc.

- Test was performed the carrier 1 and 8 case having maximum output power and maximum PSD(It means the worst case.).

- Unwanted radiated emissions test was performed on state of all EUT antenna path is operated with a maximum output power level.

- Transmitter output signals are correlated.

- Because of the EUT using TDD technology, it cannot be configured to transmit continuously and measurement instrument cannot be configured to measure only during active transmissions. So we perform the measurement using duty cycle method.

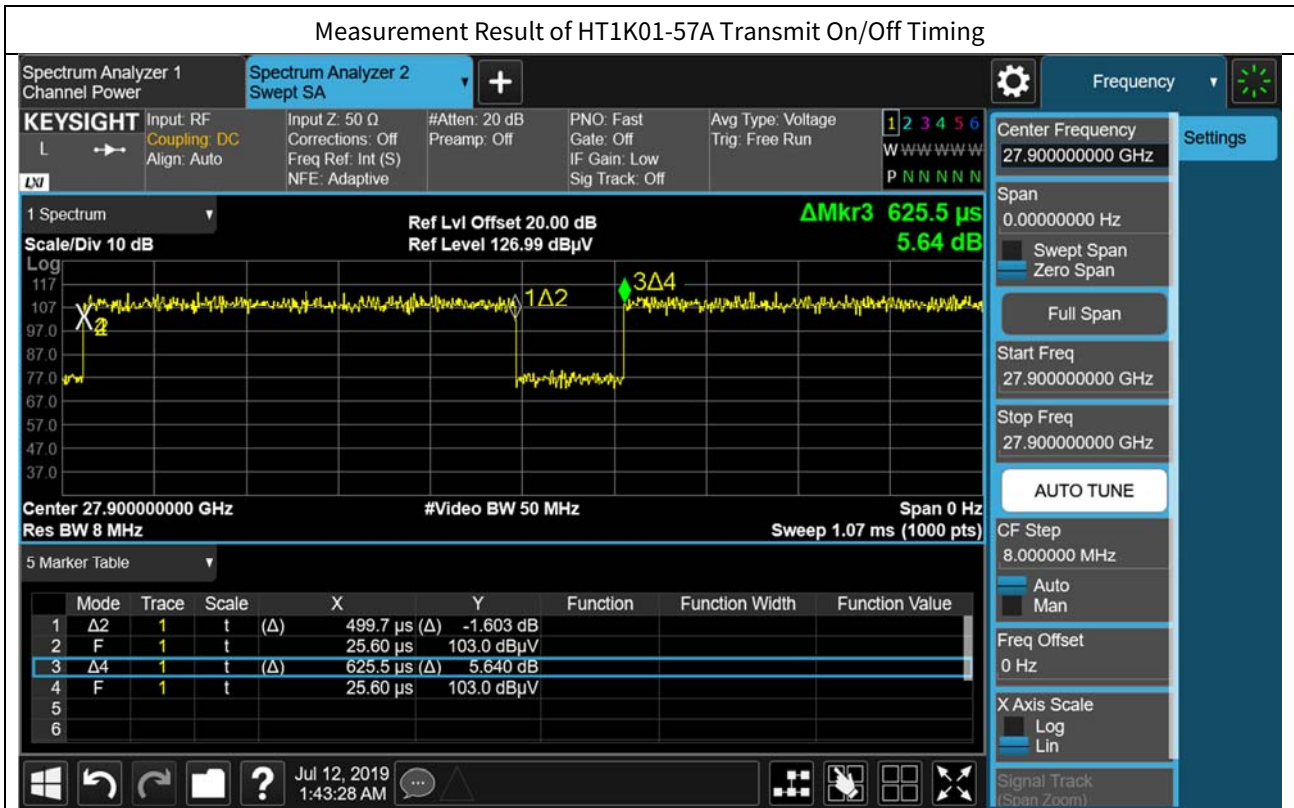

- The EUT duty cycle is calculated according to ANSI C63.26 - 5.2.4.3.4.

$$\text{Duty Cycle} = \text{On-time} / \text{Transmitter period} = 0.4997 \text{ ms} / 0.6255 \text{ ms} = 0.798$$

$$\text{Duty Correction} = 10 \log (1/\text{duty cycle}) = 10 \log (1/0.798) = 0.975 \text{ dB}$$

3.3. MAXIMUM MEASUREMENT UNCERTAINTY

The value of the measurement uncertainty for the measurement of each parameter.

Coverage factor $k=2$, Confidence levels of 95 %

Description	Condition	Uncertainty
Occupied Bandwidth	-	± 0.31 MHz
Conducted Output Power	28 GHz	± 5.05 dB
EIRP Density		
Band Edge		
Radiated Spurious Emissions	9 kHz ~ 30 MHz	± 3.40 dB
	30 MHz ~ 1 GHz	± 4.80 dB
	1 GHz ~ 18 GHz	± 5.70 dB
	18 GHz ~ 40 GHz	± 5.05 dB
	40 GHz ~ 100 GHz	± 4.59 dB
Frequency Stability	-	69.61 kHz

3.4. STANDARDS ENVIRONMENTAL TEST CONDITIONS

Temperature :	+15 °C to +35 °C
Relative humidity:	30 % to 60 %
Air pressure	860 mbar to 1 060 mbar

3.5. TEST DIAGRAMS

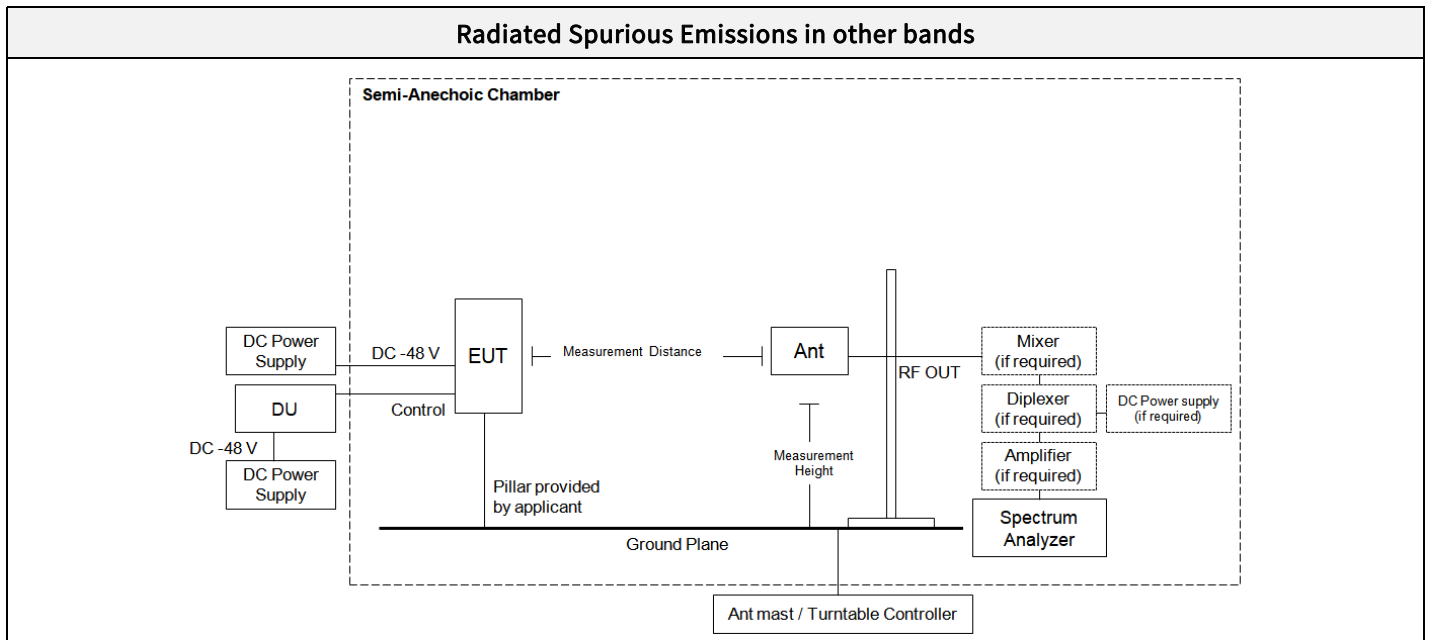
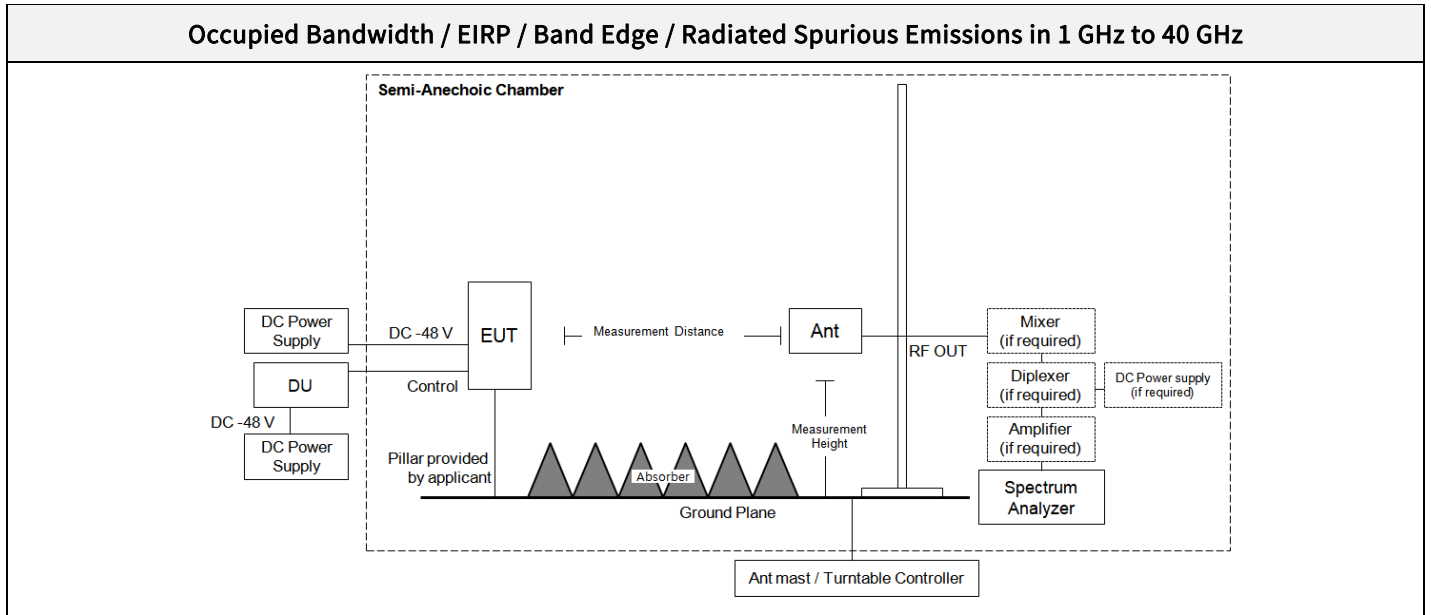

Frequency stability

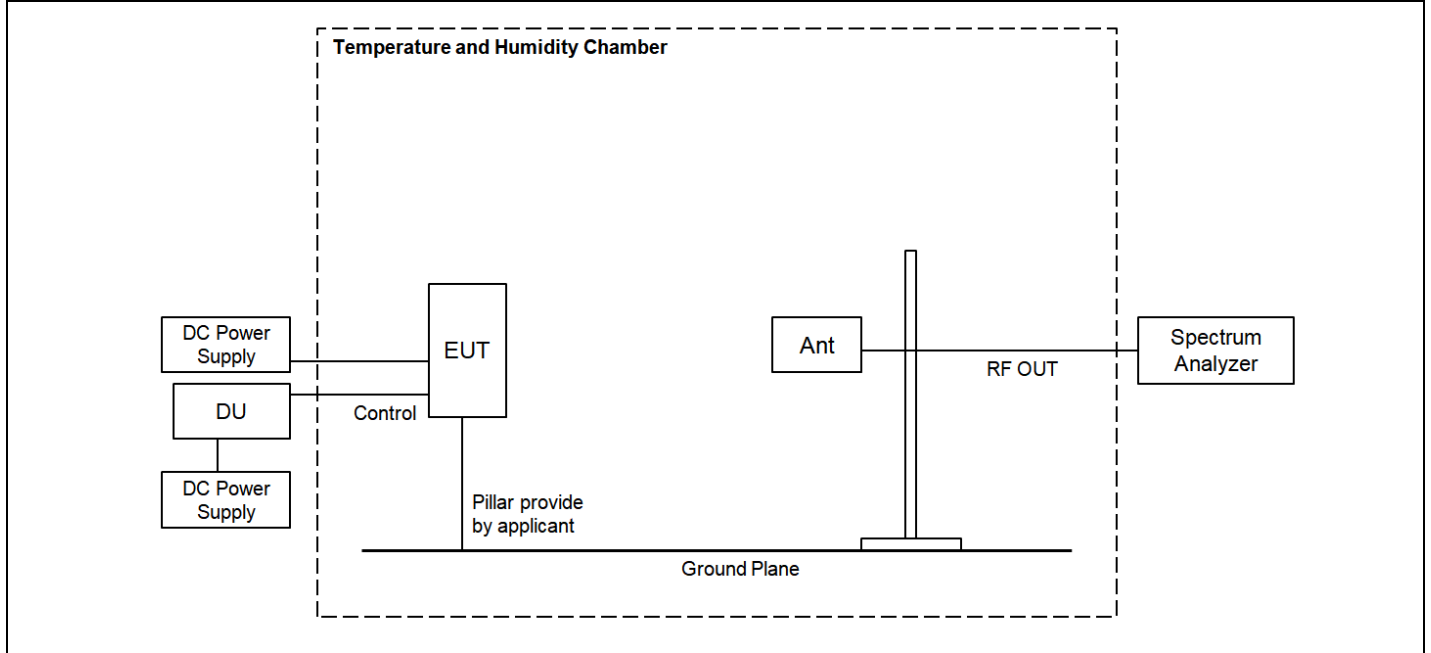

4. TEST EQUIPMENTS

Manufacturer	Model / Equipment	Calibration Date	Calibration Interval	Serial No.
Agilent	N9030B / PXA Signal Analyzer	08/29/2018	Annual	MY55480167
Schwarzbeck	BBHA 9170 / Horn Antenna	12/04/2017	Biennial	BBHA9170541
KIKUSUI	PWR800L / DC Power Supply	07/18/2019	Annual	RE002047
Innco system	CO3000 / Controller(Antenna mast)	N/A	N/A	CO3000-4p
Innco system	MA4640/800-XP-EP / Antenna Position Tower	N/A	N/A	N/A
Rohde&Schwarz	FSW / Spectrum Analyzer	09/27/2018	Annual	101256
Rohde&Schwarz	FSP / Spectrum Analyzer	09/19/2018	Annual	836650/016
Rohde & Schwarz	Loop Antenna	01/18/2019	Biennial	1513-175
Emco	2090 / Controller	N/A	N/A	060520
Ets	Turn Table	N/A	N/A	N/A
Schwarzbeck	VULB 9168 / Hybrid Antenna	08/31/2018	Biennial	00895
Schwarzbeck	BBHA 9120D / Horn Antenna	06/28/2019	Biennial	9120D-1300
OML INC.	WR-19 Horn Antenna / Horn Antenna	04/23/2018	Biennial	18042301
OML INC.	WR-19 Horn Antenna / Horn Antenna	04/23/2018	Biennial	18042302
OML INC.	WR-12 Horn Antenna / Horn Antenna	04/23/2018	Biennial	18042301
OML INC.	WR-12 Horn Antenna / Horn Antenna	04/23/2018	Biennial	18042302
OML INC.	WR-08 Horn Antenna / Horn Antenna	05/01/2018	Biennial	18050101
OML INC.	WR-08 Horn Antenna / Horn Antenna	05/01/2018	Biennial	18050102
OML INC.	OML WR19 / Harmonic Mixer	09/27/2018	Annual	W19HWD
OML INC.	OML WR12 / Harmonic Mixer	09/27/2018	Annual	W12HWD
OML INC.	OML WR08 / Harmonic Mixer	09/27/2018	Annual	W08HWD
OML INC.	WR-19 / Source Module	09/27/2018	Annual	S19MS-A-160516-1
OML INC.	WR-12 / Source Module	09/27/2018	Annual	S12MS-A-160419-1
OML INC.	WR-08 / Source Module	09/27/2018	Annual	S08MS-A-160419-1
NANGYEUL CO., LTD.	NY-THR18750 / Temperature and Humidity Chamber	10/30/2018	Annual	NY-2009012201A
Rohde & Schwarz	SMV100A / Signal Generator	07/15/2019	Annual	177633

Note:

1. Equipment listed above that calibrated during the testing period was set for test after the calibration.
2. Equipment listed above that has a calibration due date during the testing period, the testing is completed before equipment expiration date.

5. TEST RESULT

5.1. OCCUPIED BANDWIDTH

FCC Rules

Test Requirements:

§ 2.1049 Measurements required: Occupied bandwidth.

The occupied bandwidth, that is the frequency bandwidth such that, below its lower and above its upper frequency limits, the mean powers radiated are each equal to 0.5 percent of the total mean power radiated by a given emission shall be measured under the specified conditions of § 2.1049 (a) through (i) as applicable.

Test Procedures:

The measurement is performed in accordance with Section 5.4.3 and 5.4.4 of ANSI C63.26.

5.4.3 Occupied bandwidth—Relative measurement procedure

- a) The spectrum analyzer center frequency is set to the nominal EUT channel center frequency. The span range for the spectrum analyzer shall be wide enough to see sufficient roll off of the signal to make the measurement.
- b) The nominal RBW shall be in the range of 1% to 5% of the anticipated OBW, and the VBW shall be set $\geq 3 \times$ RBW.
- c) Set the reference level of the instrument as required to prevent the signal amplitude from exceeding the maximum spectrum analyzer input mixer level for linear operation. See guidance provided in 4.2.3.

NOTE—Step a), step b), and step c) may require iteration to adjust within the specified tolerances.

- d) The dynamic range of the spectrum analyzer at the selected RBW shall be more than 10 dB below the target “-X dB” requirement, i.e., if the requirement calls for measuring the -26 dB OBW, the spectrum analyzer noise floor at the selected RBW shall be at least 36 dB below the reference level.
- e) Set spectrum analyzer detection mode to peak, and the trace mode to max hold.
- f) Determine the reference value by either of the following:
 - 1) Set the EUT to transmit a modulated signal. Allow the trace to stabilize. Set the spectrum analyzer marker to the highest level of the displayed trace (this is the reference value).
 - 2) Set the EUT to transmit an unmodulated carrier. Set the spectrum analyzer marker to the level of the carrier.
- g) Determine the “-X dB amplitude” as equal to (Reference Value - X). Alternatively, this calculation can be performed on the spectrum analyzer using the delta-marker measurement function.
- h) If the reference value was determined using an unmodulated carrier, turn the EUT modulation on, then either clear the existing trace or start a new trace on the spectrum analyzer and allow the new trace to stabilize. Otherwise the trace from step f) shall be used for step i).
- i) Place two markers, one at the lowest and the other at the highest frequency of the envelope of the spectral display such that each marker is at or slightly below the “-X dB amplitude” determined in step f). If a marker is below this “-X dB amplitude” value it should be as close as possible to this value. The OBW is the positive frequency difference between the two markers. The spectral envelope can cross the “-X dB amplitude” at multiple points. The lowest or highest frequency shall be selected as the frequencies that are the farthest away from the center frequency at which the spectral envelope crosses the “-X dB amplitude.”
- j) The OBW shall be reported by providing plot(s) of the measuring instrument display, to include markers depicting the relevant frequency and amplitude information (e.g., marker table). The frequency and amplitude axis and scale shall be clearly labeled. Tabular data may be reported in addition to the plot(s).

5.4.4 Occupied bandwidth—Power bandwidth (99%) measurement procedure

- a) The spectrum analyzer center frequency is set to the nominal EUT channel center frequency. The frequency span for the spectrum analyzer shall be set wide enough to capture all modulation products including the emission skirts (typically a span of $1.5 \times$ OBW is sufficient).
- b) The nominal IF filter 3 dB bandwidth (RBW) shall be in the range of 1% to 5% of the anticipated OBW, and the VBW shall be

set $\geq 3 \times \text{RBW}$.

c) Set the reference level of the instrument as required to prevent the signal amplitude from exceeding the maximum spectrum analyzer input mixer level for linear operation. See guidance provided in 4.2.3.

NOTE—Step a), step b), and step c) may require iteration to adjust within the specified tolerances.

d) Set the detection mode to peak, and the trace mode to max-hold.

e) If the instrument does not have a 99% OBW function, recover the trace data points and sum directly in linear power terms. Place the recovered amplitude data points, beginning at the lowest frequency, in a running sum until 0.5% of the total is reached. Record that frequency as the lower OBW frequency. Repeat the process until 99.5% of the total is reached and record that frequency as the upper OBW frequency. The 99% power OBW can be determined by computing the difference these two frequencies.

f) The OBW shall be reported and plot(s) of the measuring instrument display shall be provided with the test report. The frequency and amplitude axis and scale shall be clearly labeled. Tabular data can be reported in addition to the plot(s).

Test Results:
Tabular Data of Occupied Bandwidth

Ant.	Ant. Angle	CC	Channel	Freq. (GHz)	Mod.	Measured OBW (MHz)
A	135°	1	Middle	27.925	QPSK	97.851
					16QAM	97.839
					64QAM	97.886
		8			QPSK	787.814
					16QAM	787.527
					64QAM	786.785
B	45°	1			QPSK	97.734
					16QAM	97.767
					64QAM	97.722
		8			QPSK	787.678
					16QAM	785.749
					64QAM	786.059
C	135°	1	QPSK	96.968		
			16QAM	97.079		
			64QAM	96.959		
		8	QPSK	787.620		
			16QAM	786.622		
			64QAM	786.727		
D	45°	1	QPSK	97.565		
			16QAM	97.613		
			64QAM	97.556		
		8	QPSK	786.890		
			16QAM	786.562		
			64QAM	786.458		

Plot Data of RF Occupied Bandwidth

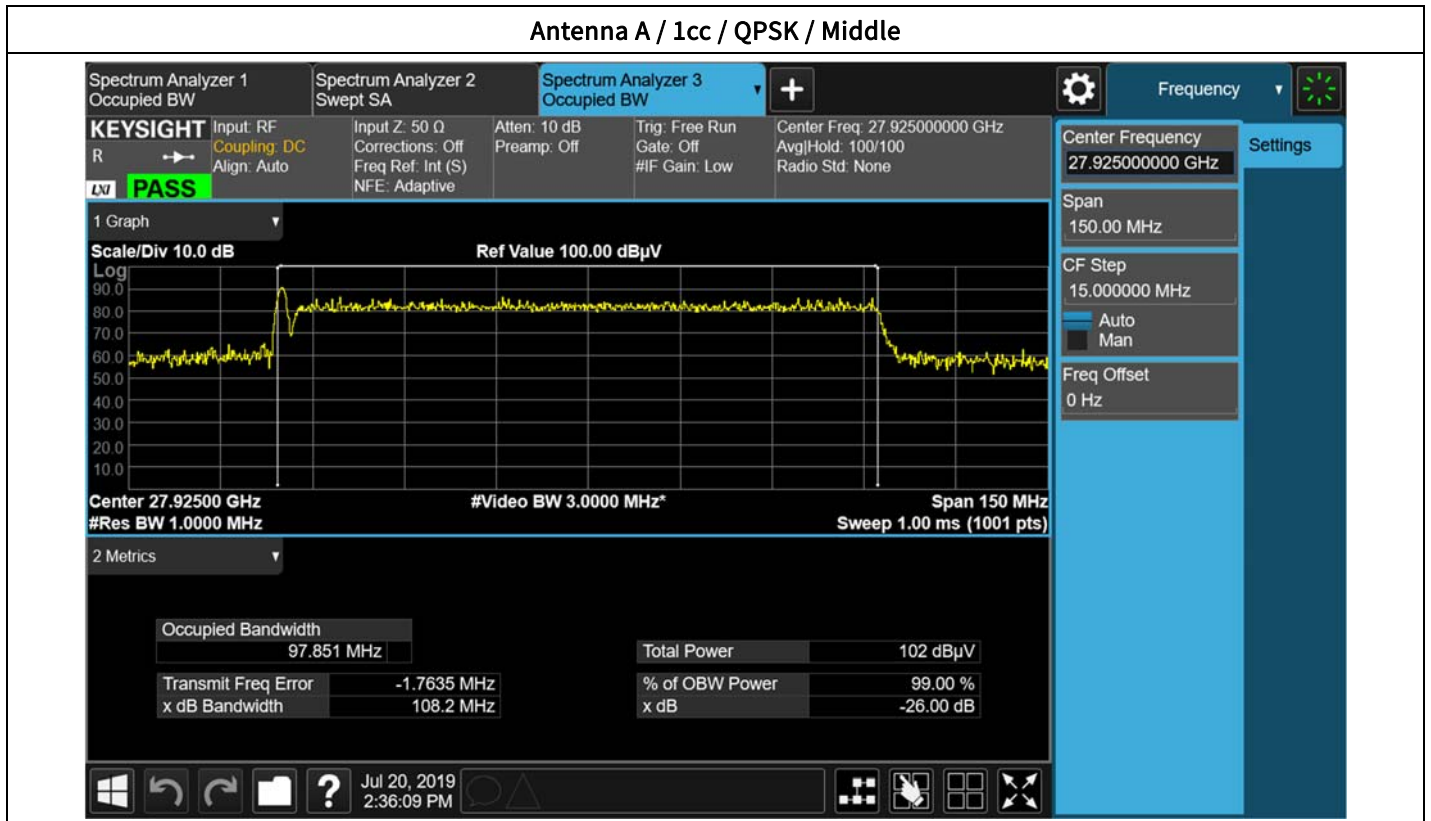

Antenna A / 1cc / 64QAM / Middle

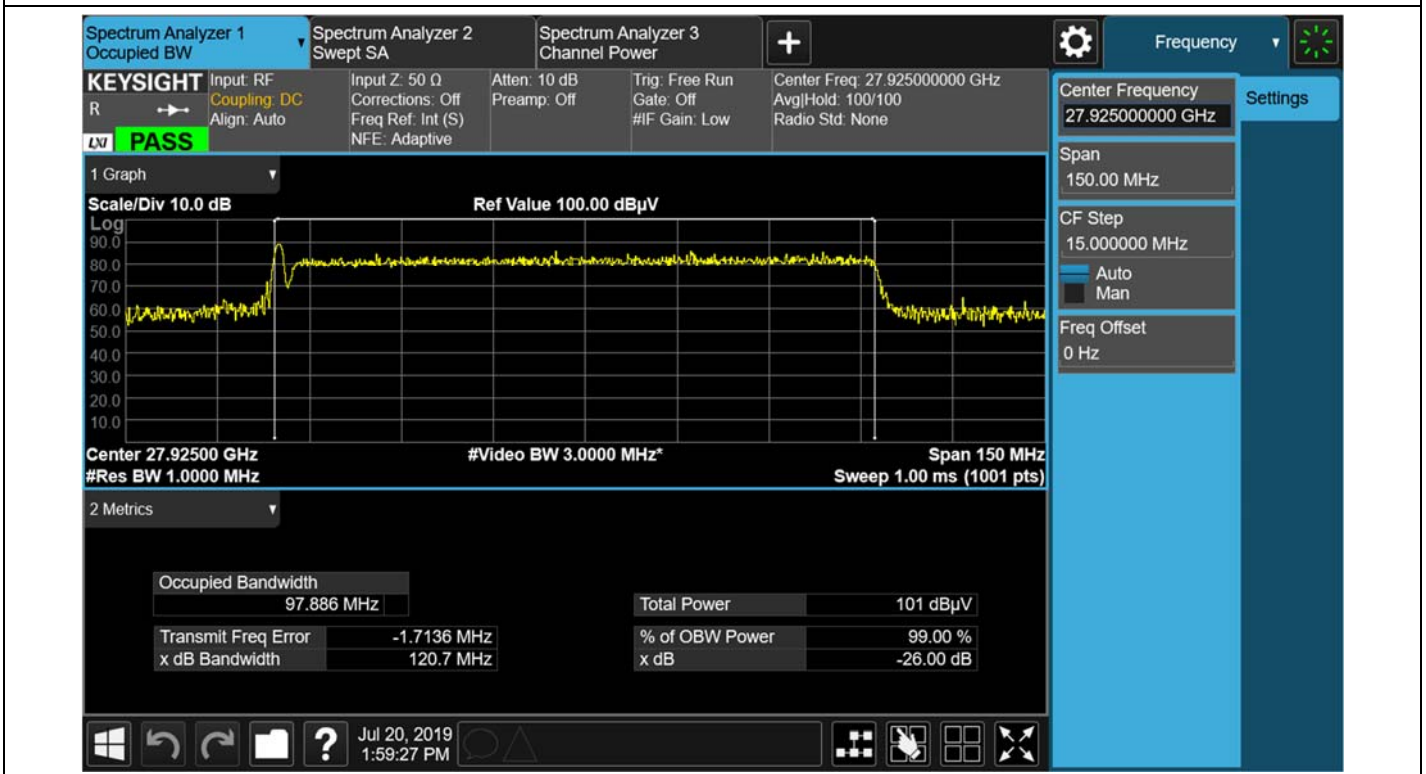

Antenna A / 8cc / QPSK / Middle

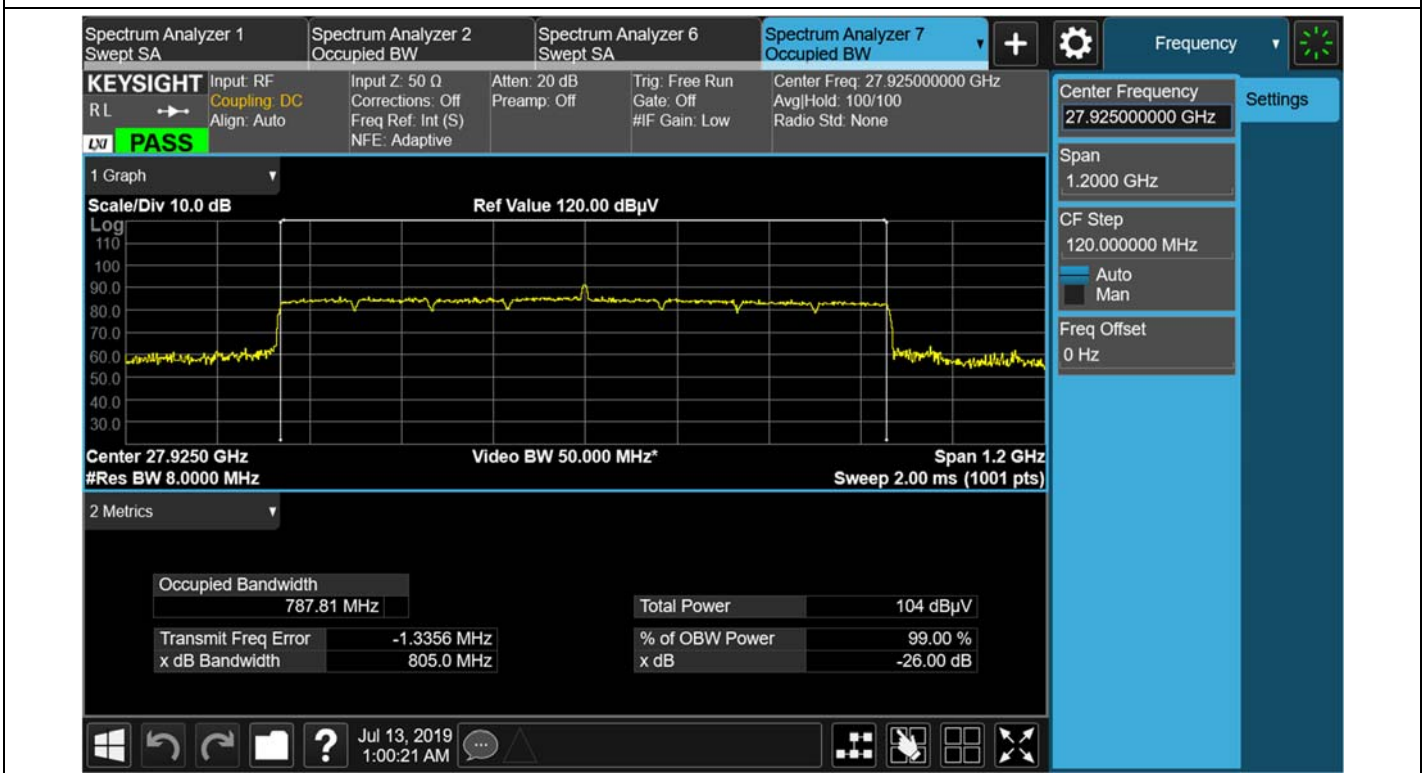

Antenna A / 8cc / 16QAM / Middle

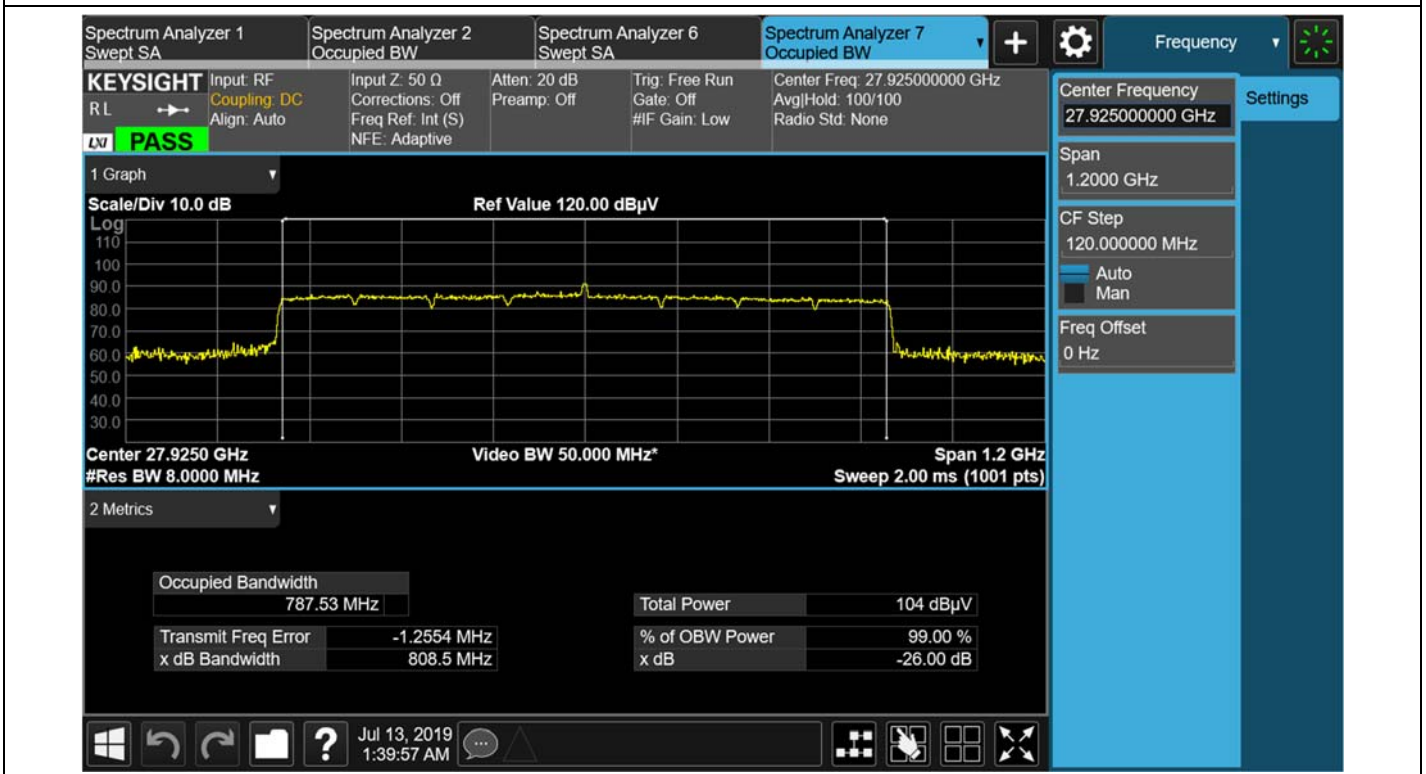

Antenna A / 8cc / 64QAM / Middle

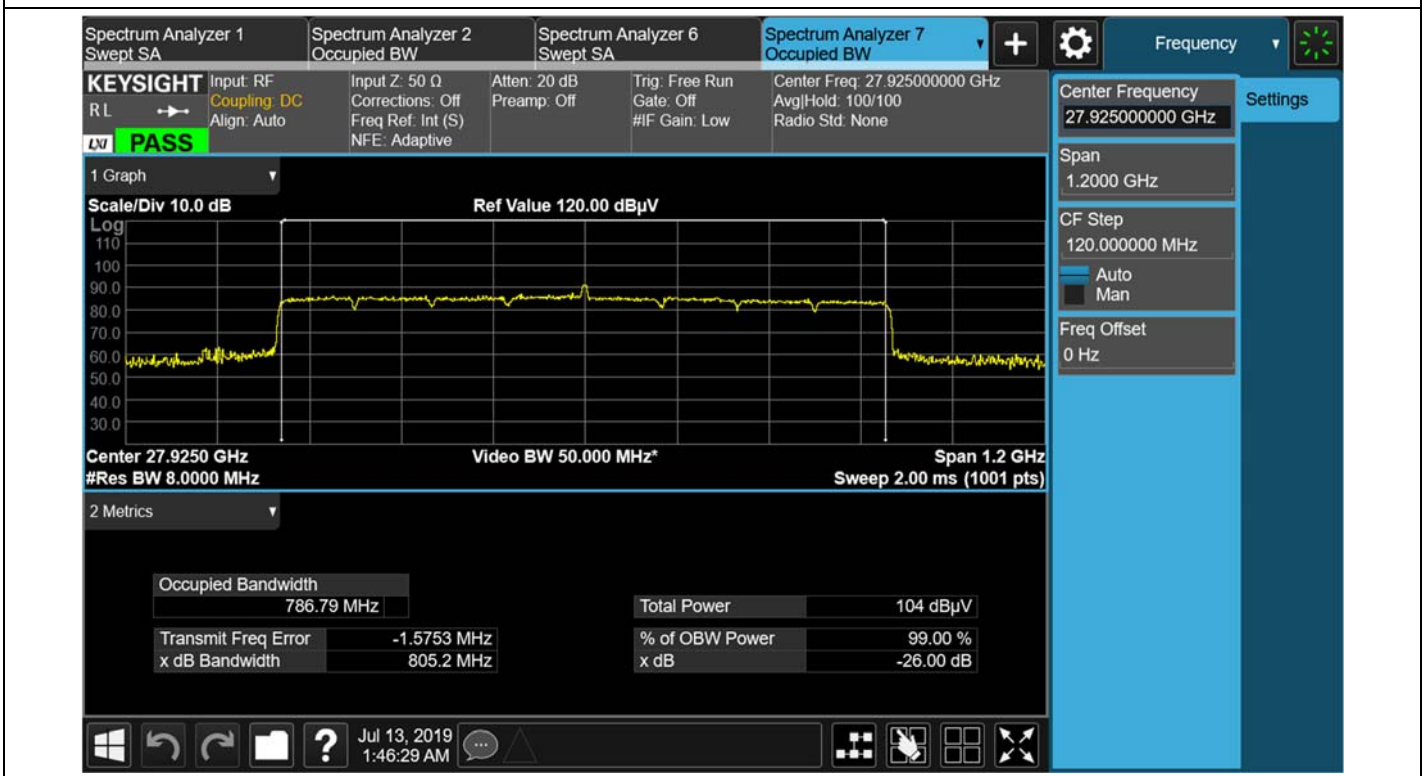

Antenna B / 1cc / QPSK / Middle

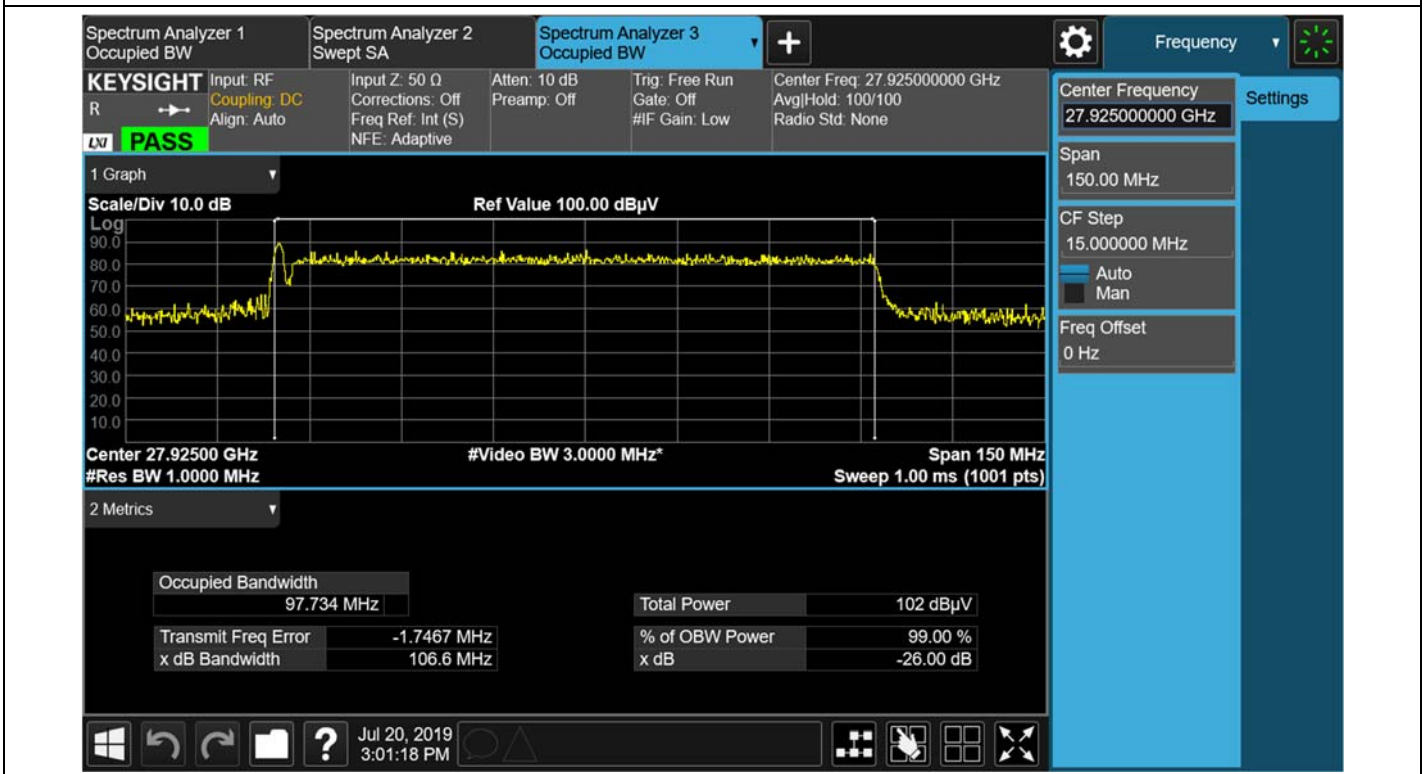

Antenna B / 1cc / 16QAM / Middle

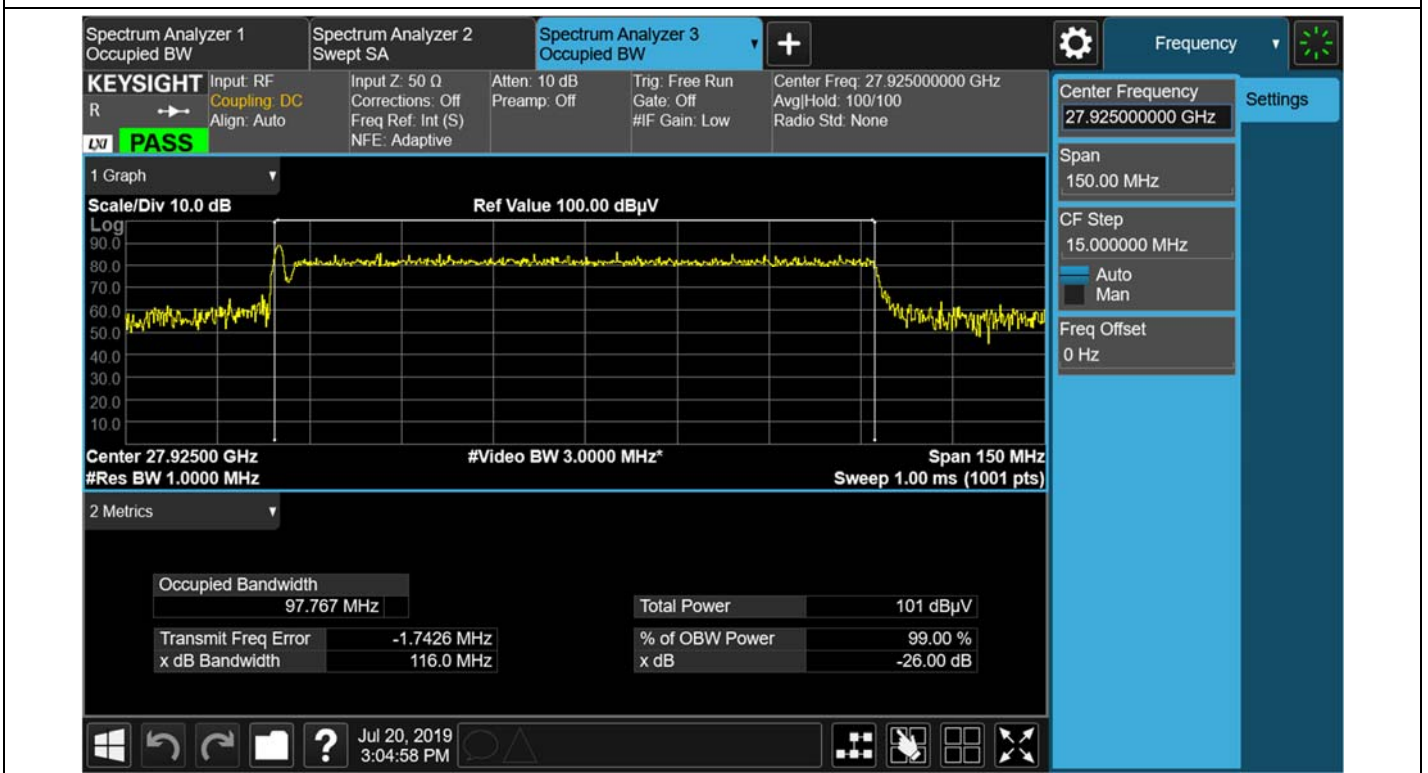

Antenna B / 1cc / 64QAM / Middle

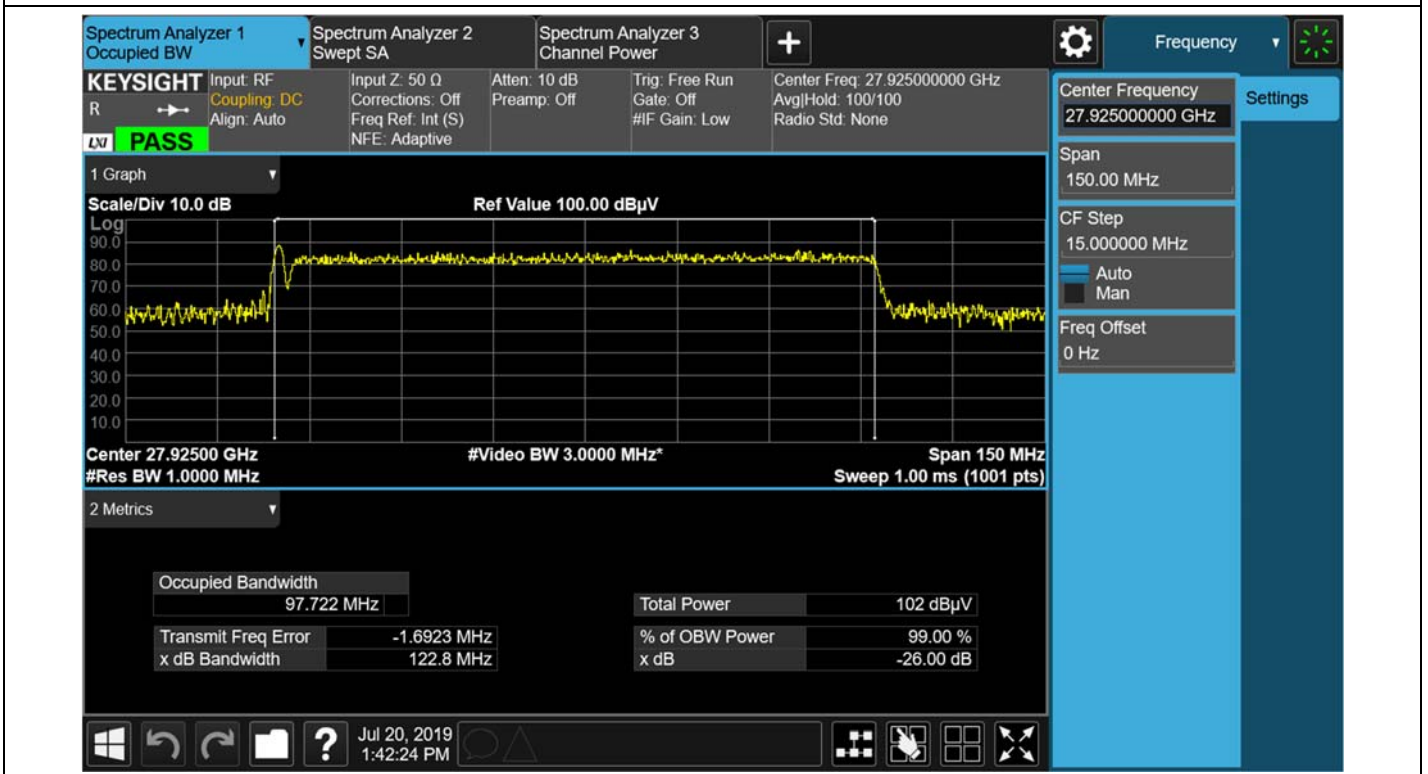

Antenna B / 8cc / QPSK / Middle

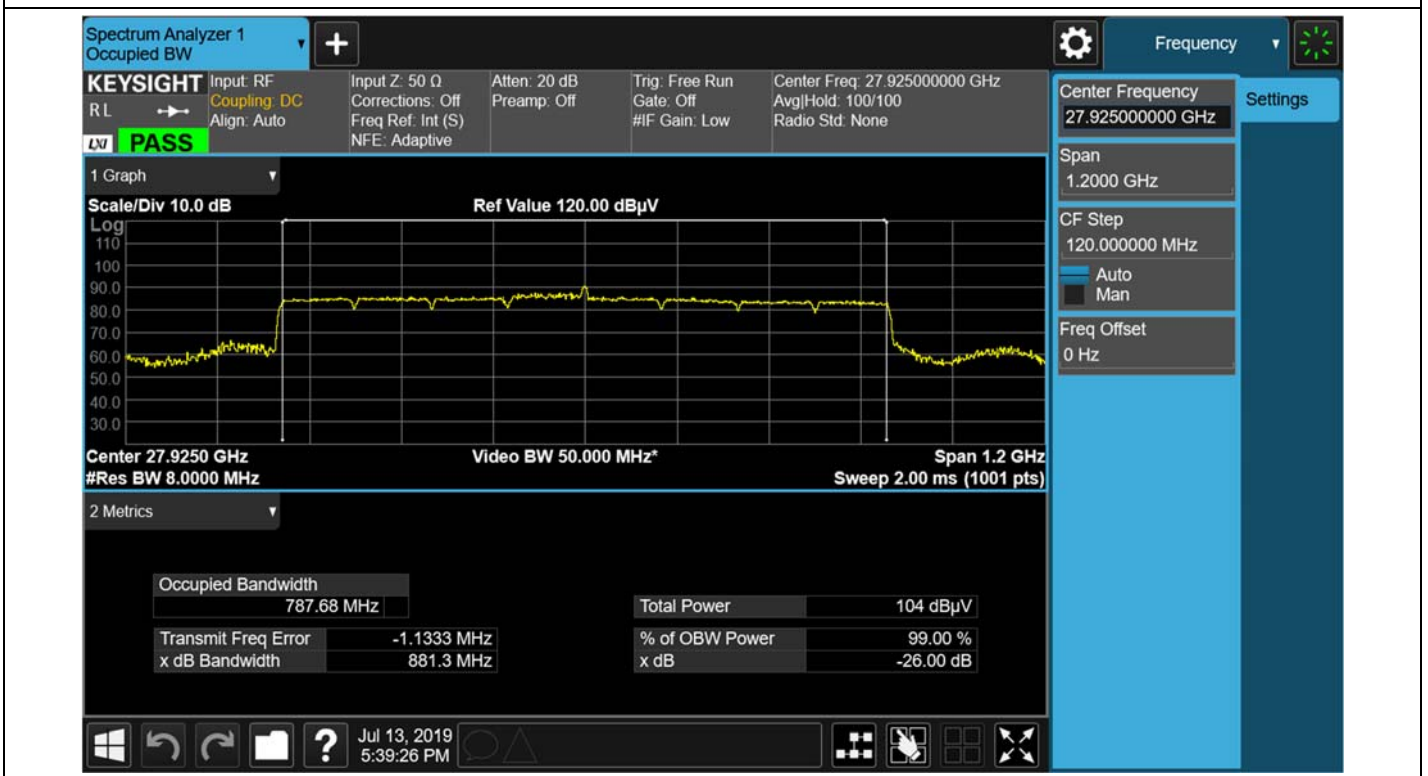

Antenna B / 8cc / 16QAM / Middle

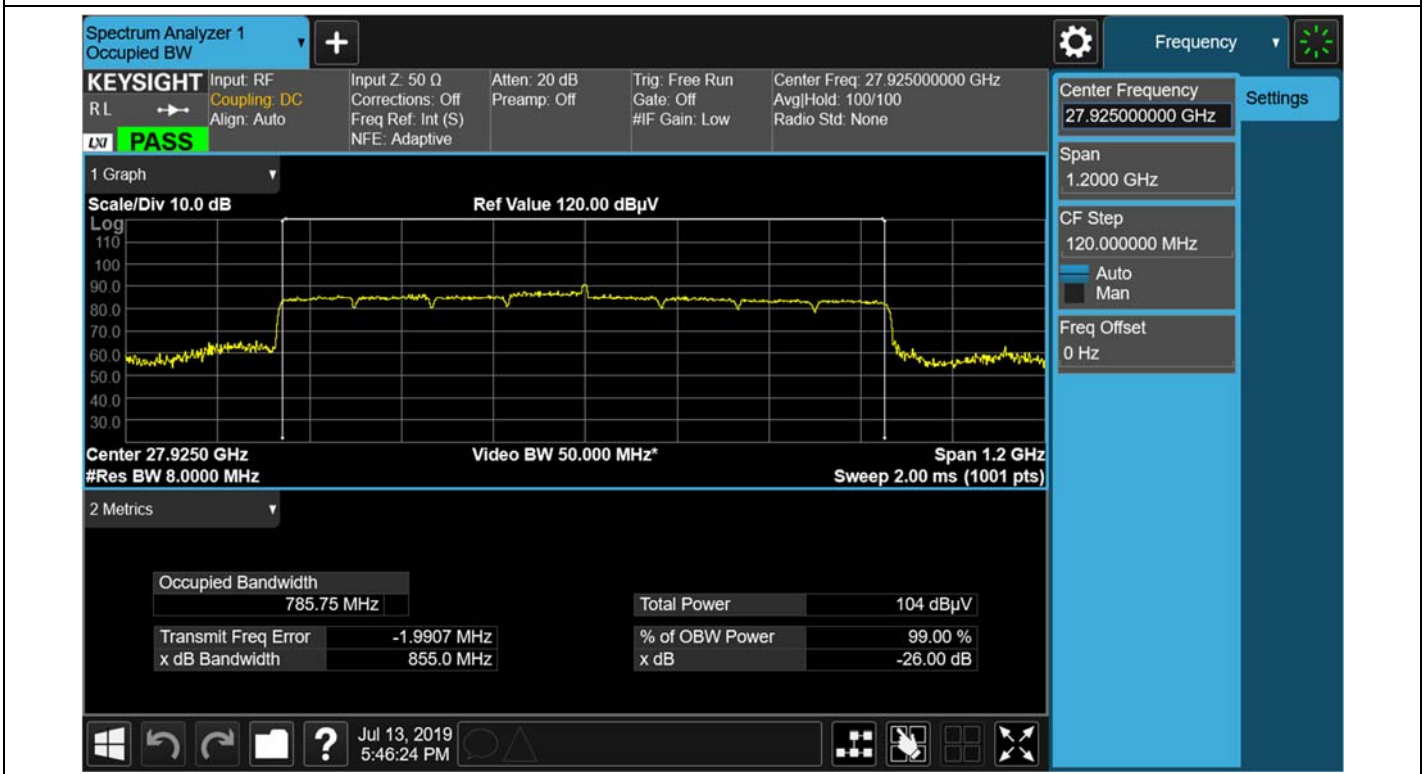

Antenna B / 8cc / 64QAM / Middle

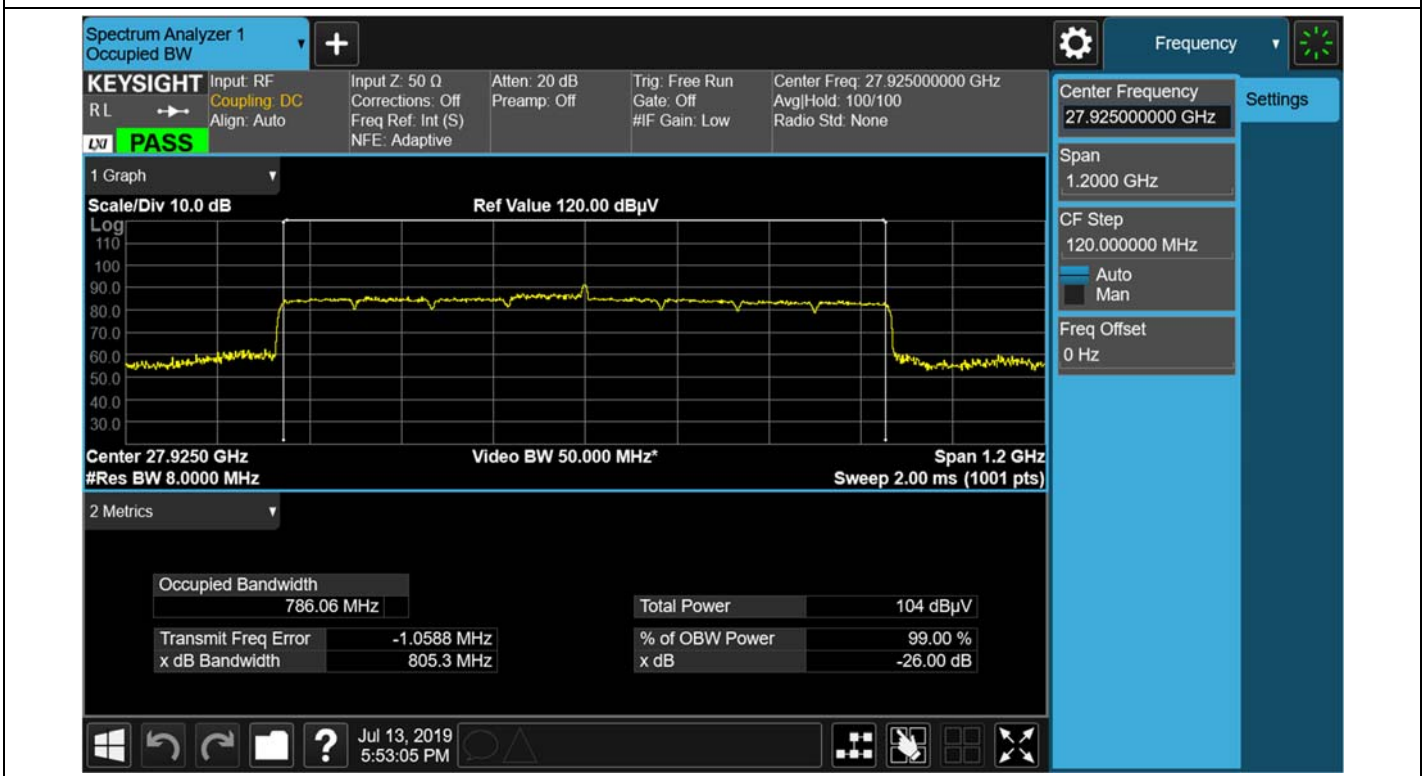

Antenna C / 1cc / QPSK / Middle

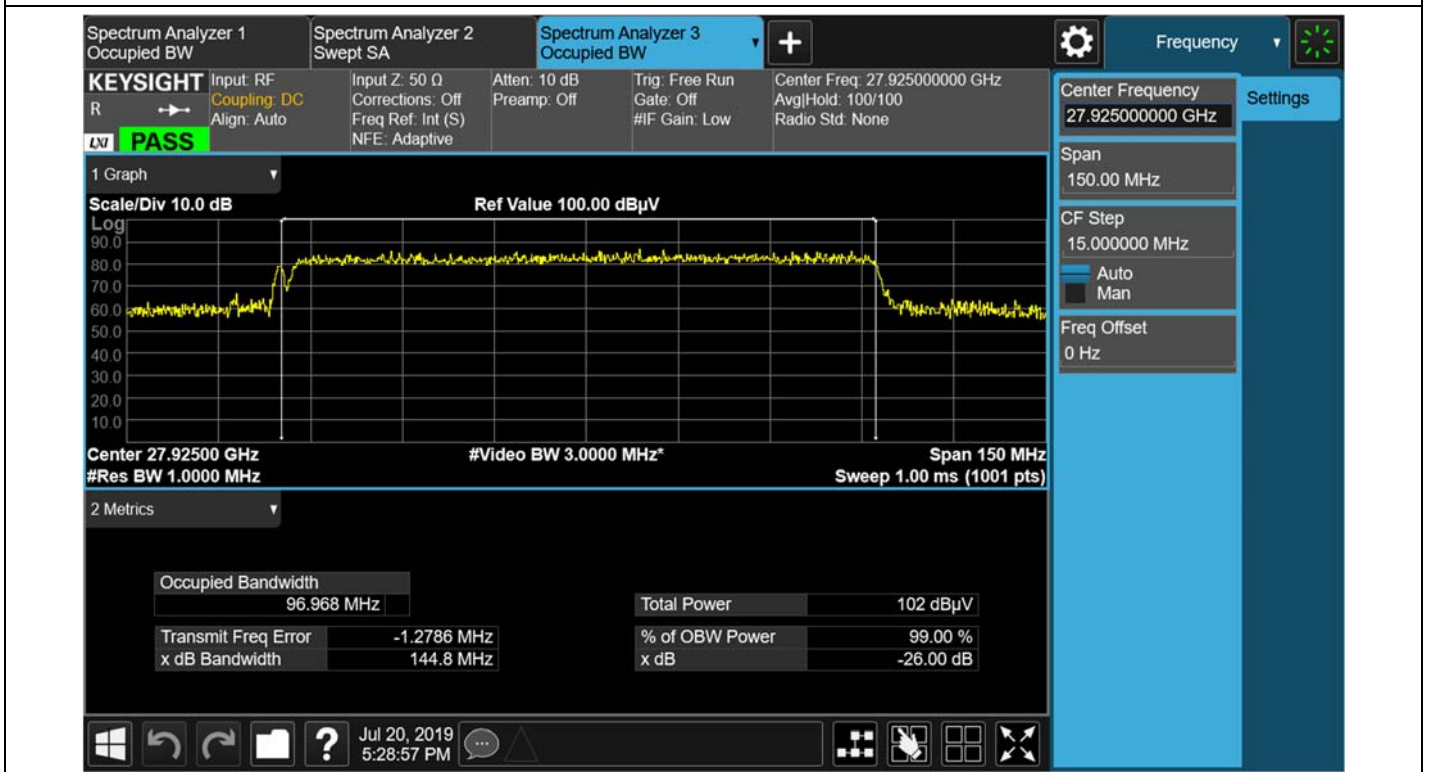

Antenna C / 1cc / 16QAM / Middle

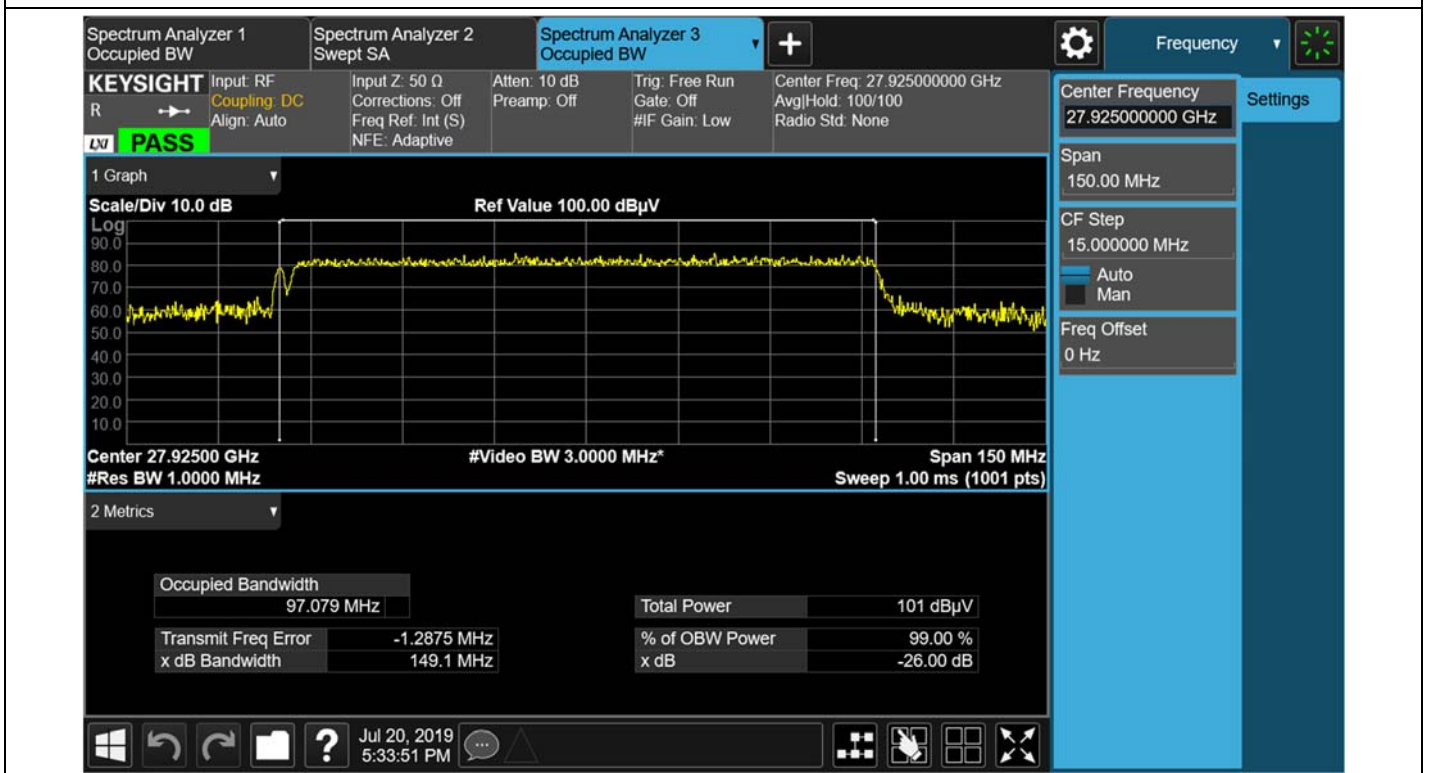

Antenna C / 1cc / 64QAM / Middle

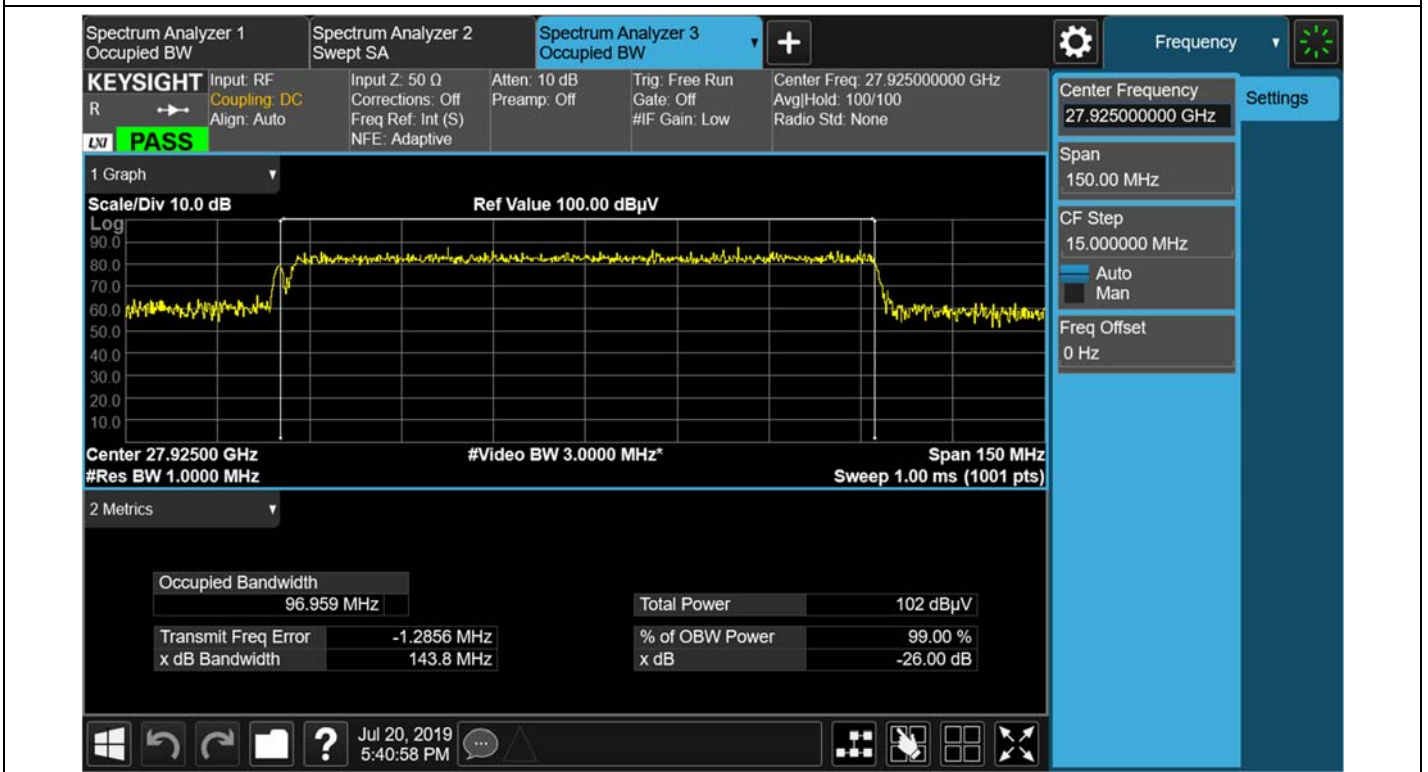

Antenna C / 8cc / QPSK / Middle

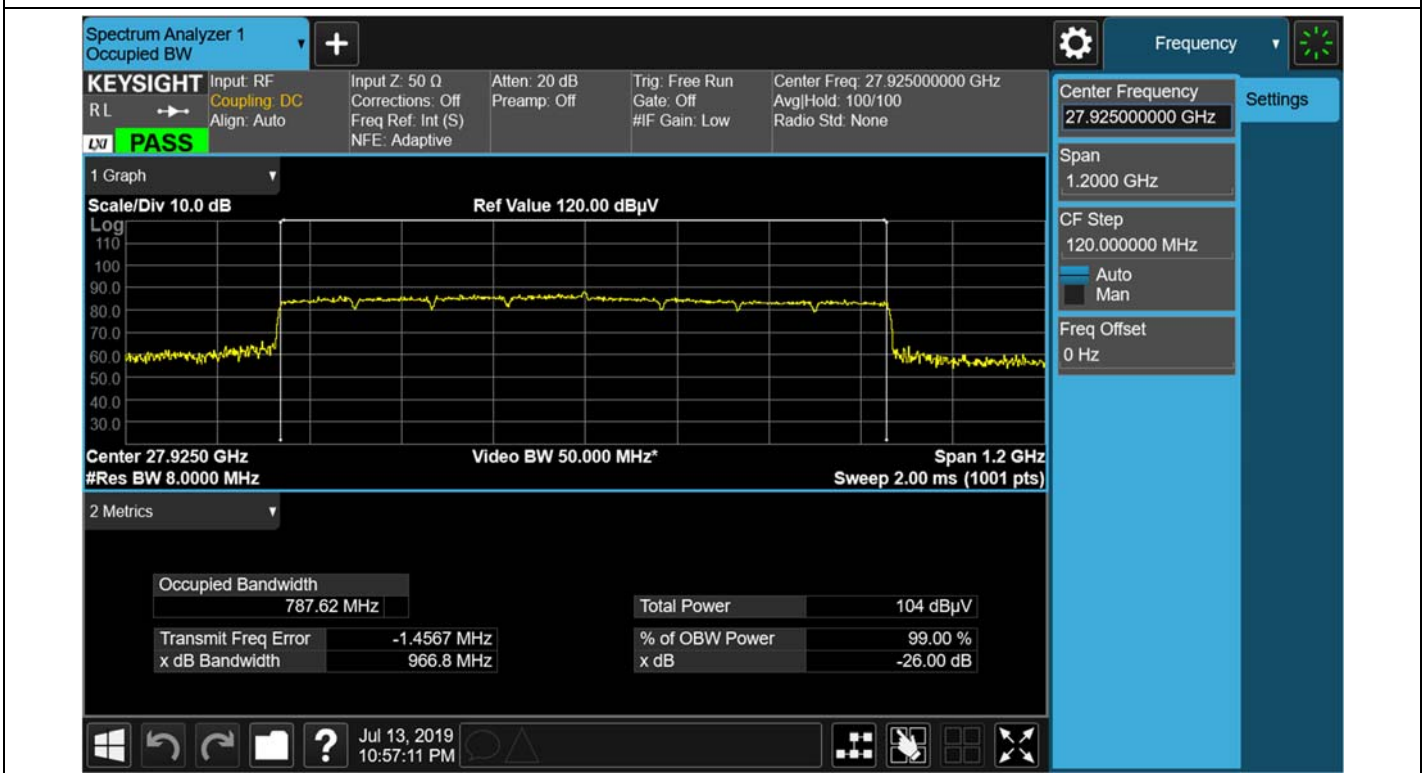

Antenna C / 8cc / 16QAM / Middle

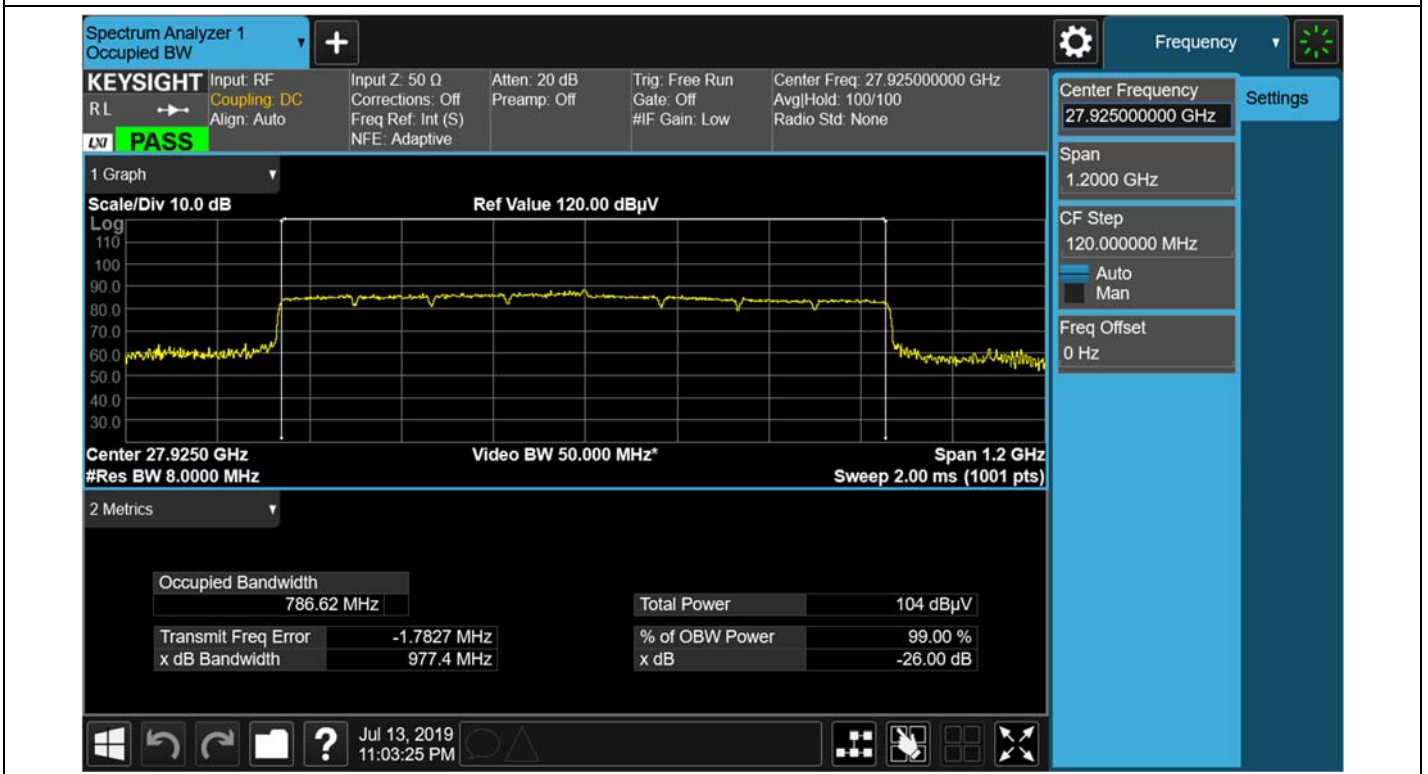

Antenna C / 8cc / 64QAM / Middle

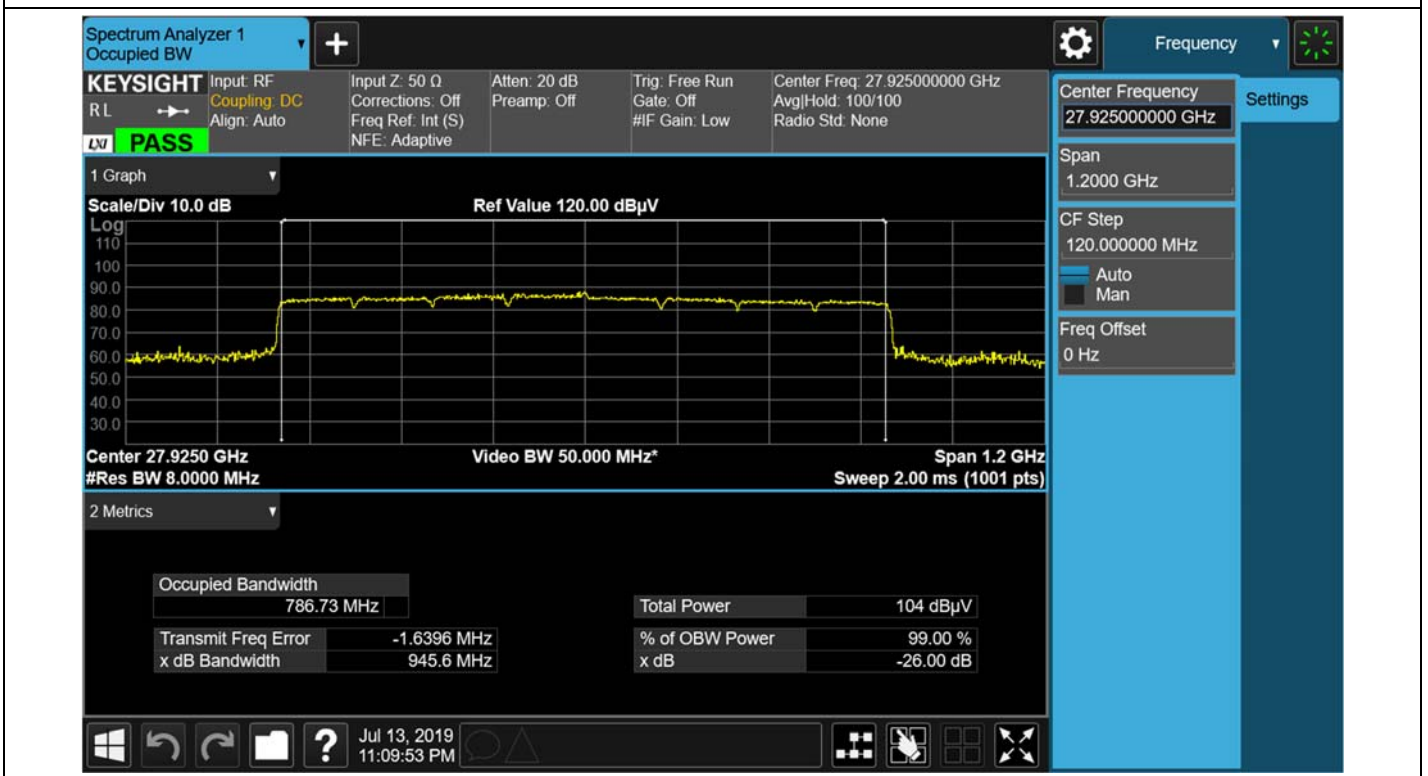

Antenna D / 1cc / QPSK / Middle

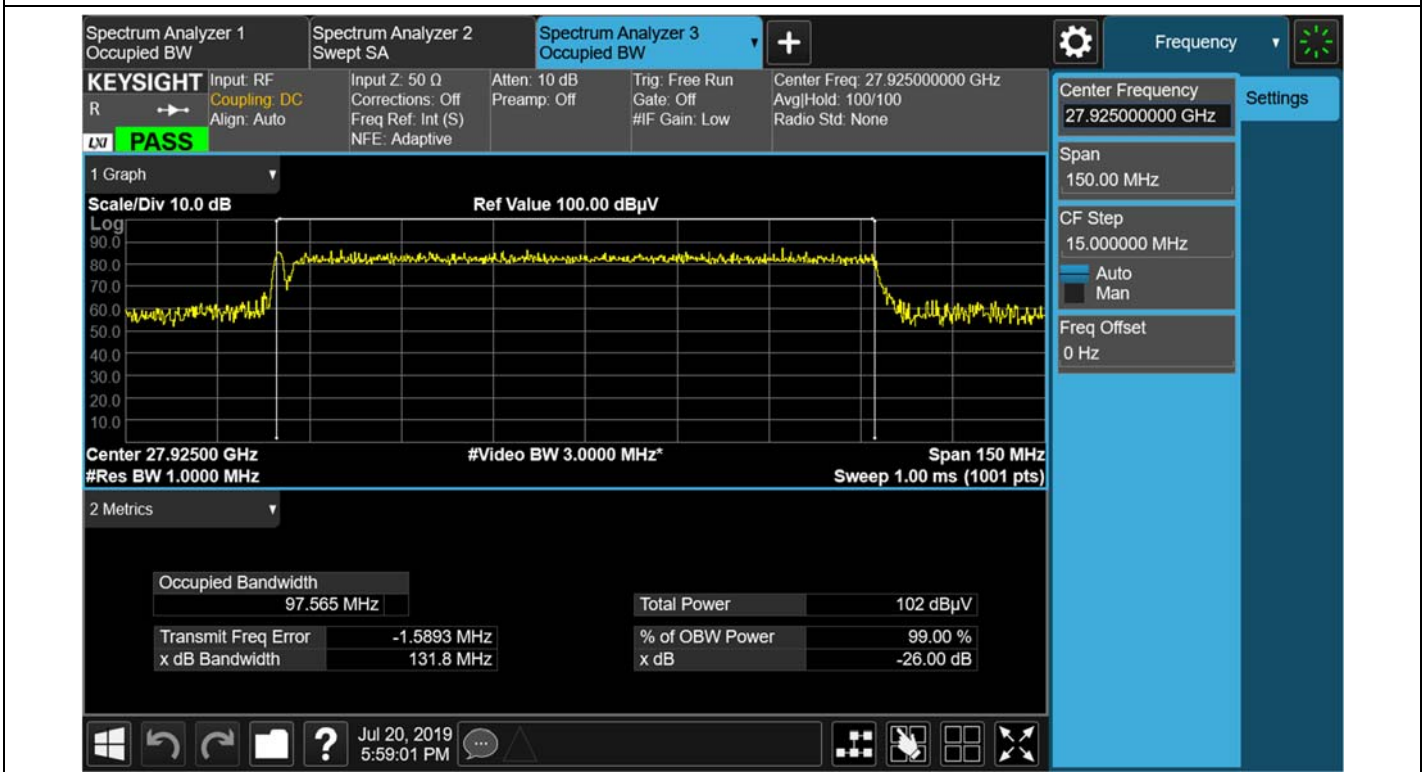

Antenna D / 1cc / 16QAM / Middle

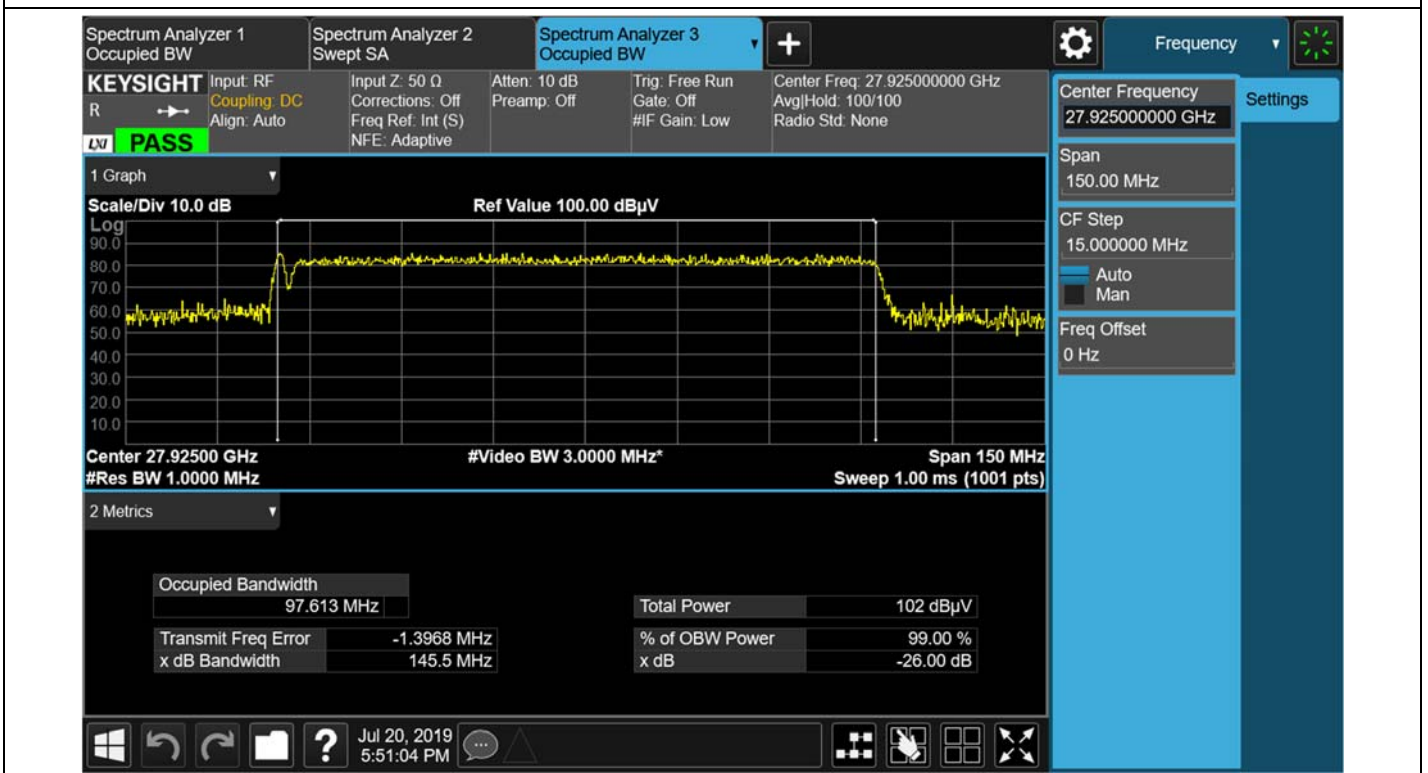

Antenna D / 1cc / 64QAM / Middle

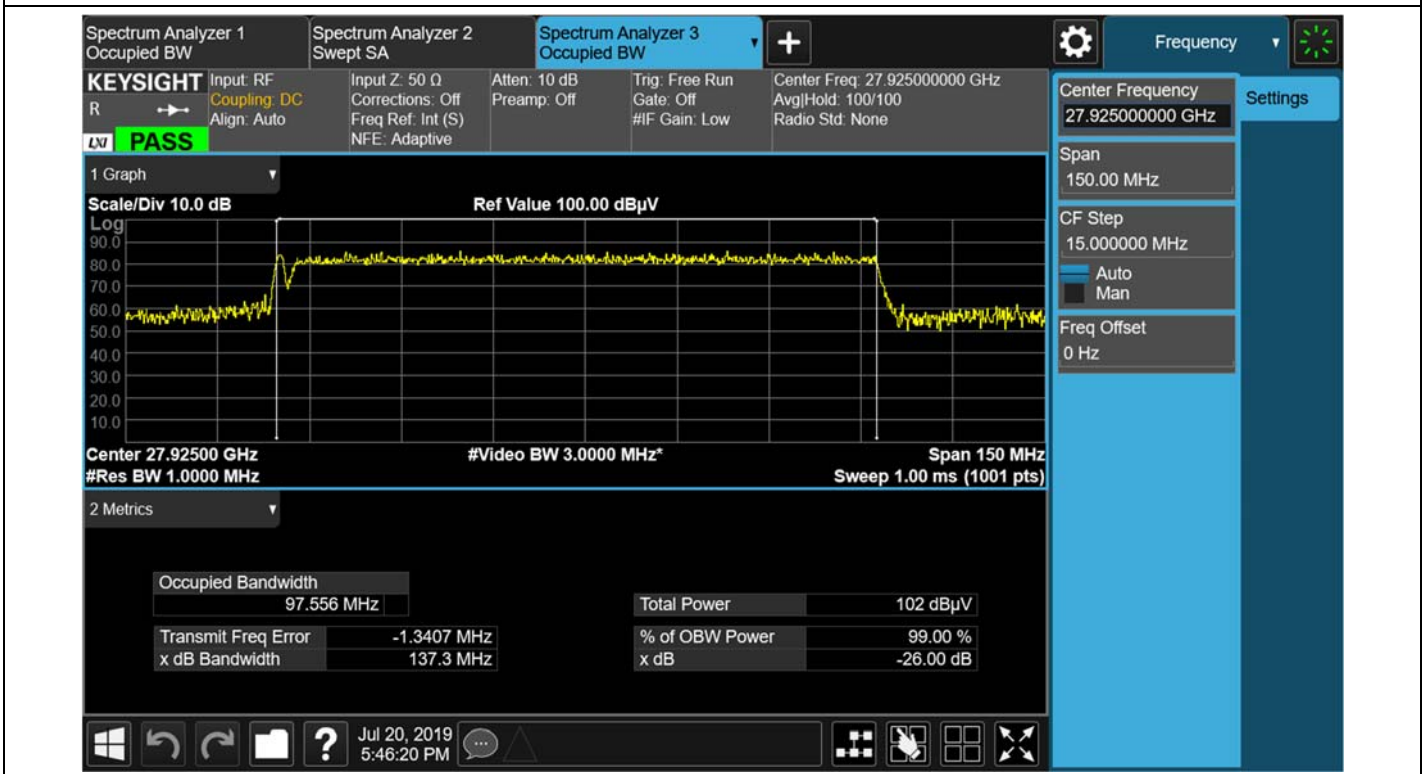

Antenna D / 8cc / QPSK / Middle

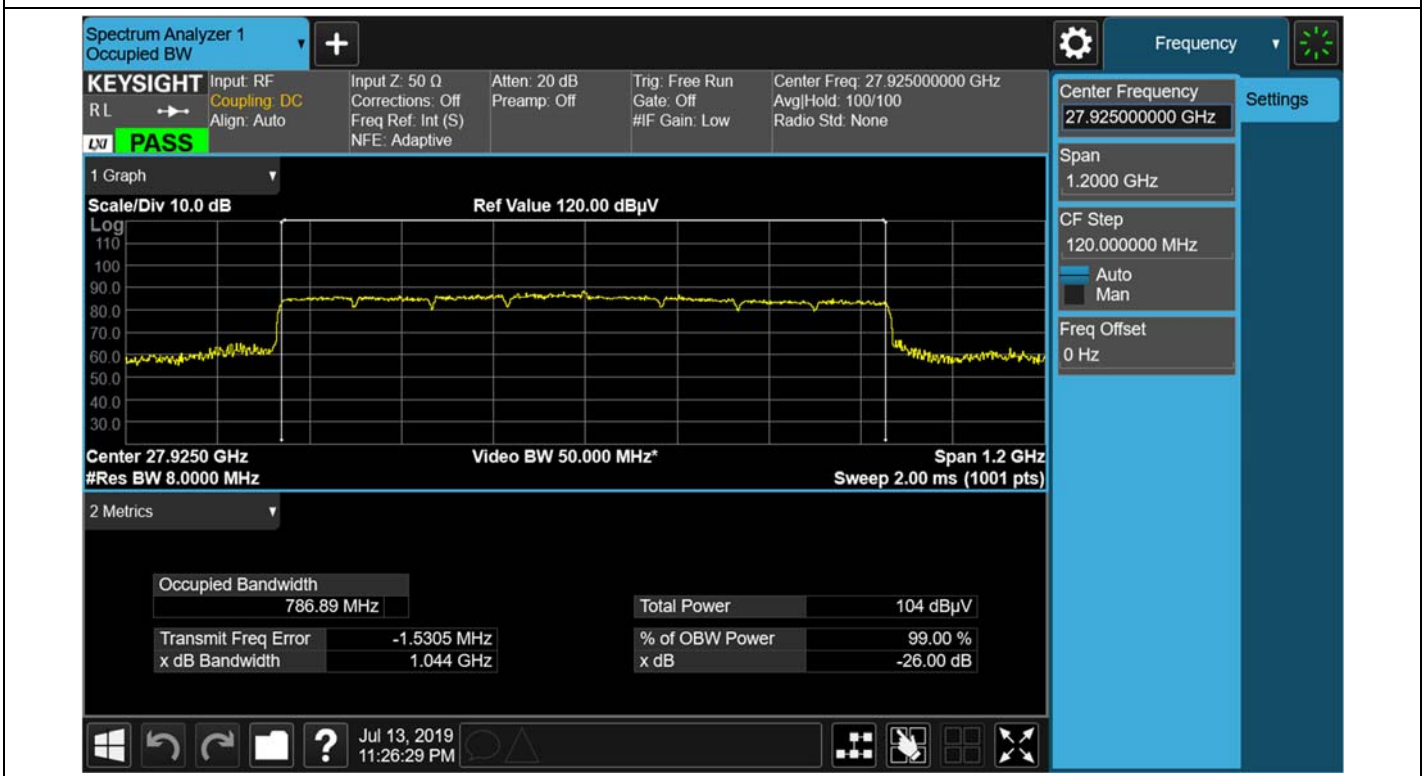

Antenna D / 8cc / 16QAM / Middle

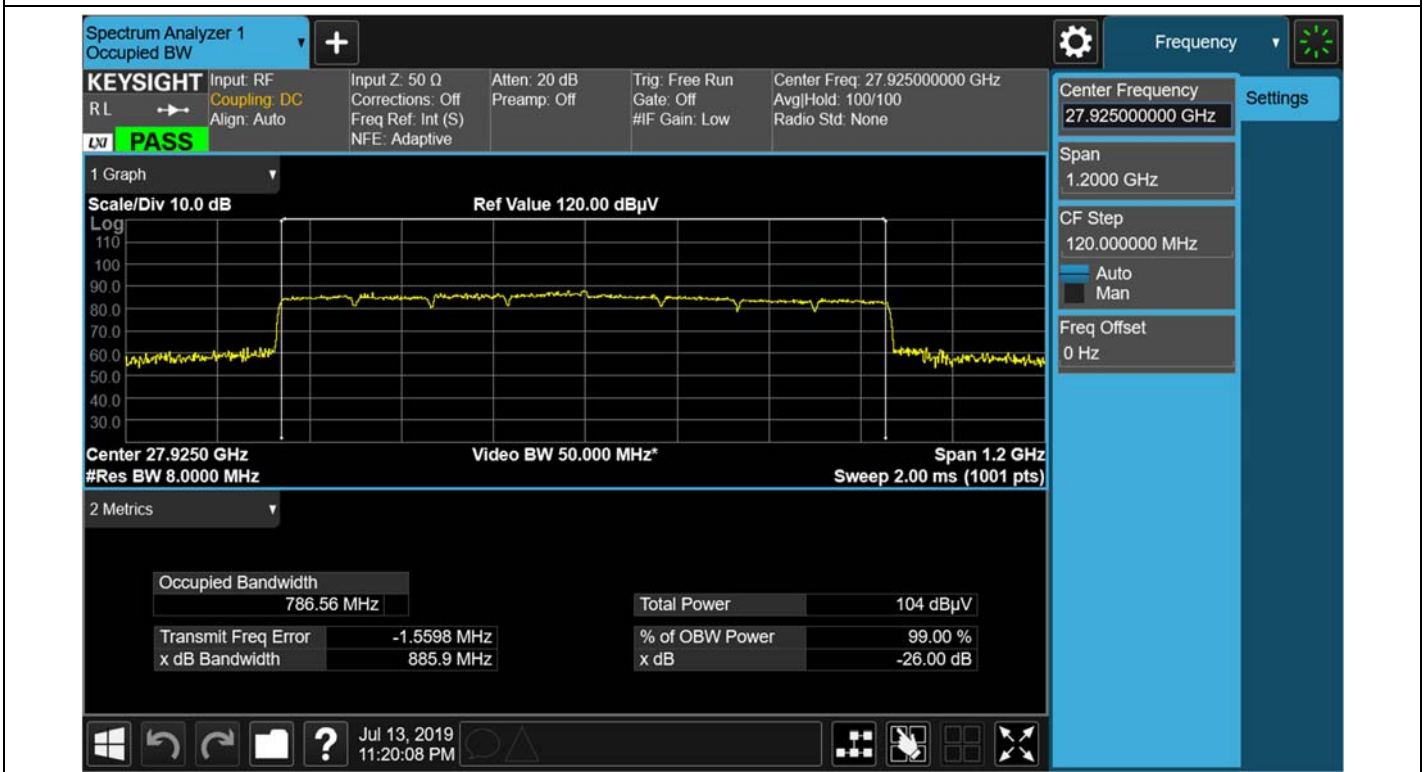

Antenna D / 8cc / 64QAM / Middle

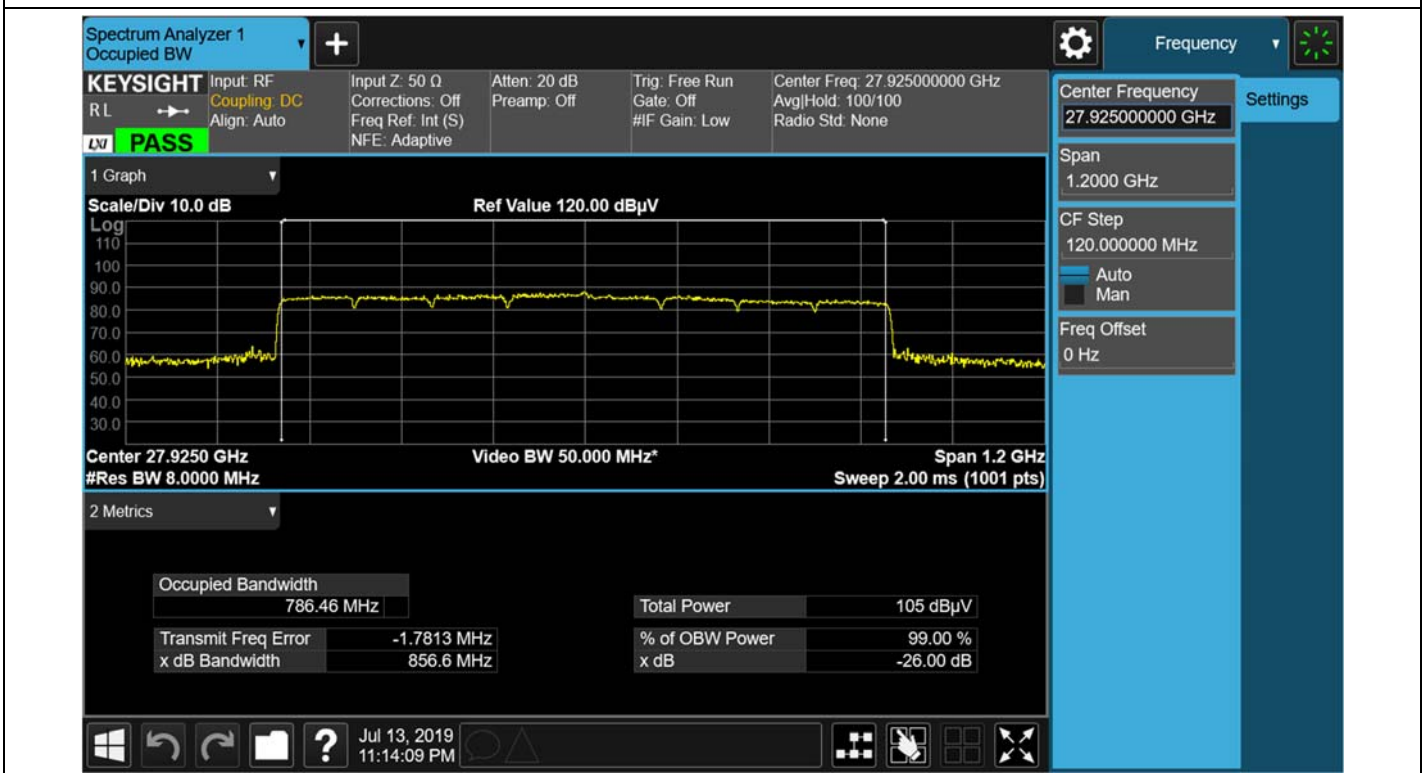

5.2. EIRP DENSITY

FCC Rules

Test Requirements:

§ 30.202 Power limits.

(a) For fixed and base stations operating in connection with mobile systems, the average power of the sum of all antenna elements is limited to an equivalent isotopically radiated power (EIRP) density of +75dBm/100 MHz. For channel bandwidths less than 100 megahertz the EIRP must be reduced proportionally and linearly based on the bandwidth relative to 100 megahertz.

Test Procedures:

The measurement is performed in accordance with Section 5.2.4.4.2 of ANSI C63.26.

- a) Set span to 2 × to 3 × the OBW.
- b) Set RBW = 1% to 5% of the OBW.
- c) Set VBW ≥ 3 × RBW.
- d) Set number of measurement points in sweep ≥ 2 × span / RBW.
- e) Sweep time:
 - 1) Set = auto-couple, or
 - 2) Set ≥ [10 × (number of points in sweep) × (transmission symbol period)] for single sweep (automation-compatible) measurement.
- f) Detector = power averaging (rms).
- g) Set sweep trigger to “free run.”
- h) Trace average at least 100 traces in power averaging (rms) mode if sweep is set to auto-couple. To accurately determine the average power over the on and off time of the transmitter, it can be necessary to increase the number of traces to be averaged above 100, or if using a manually configured sweep time, increase the sweep time.
- i) Compute power by integrating the spectrum across the OBW of the signal using the instrument’s band or channel power measurement function with band/channel limits set equal to the OBW band edges. If the instrument does not have a band or channel power function, sum the spectrum levels (in linear power units) at intervals equal to the RBW extending across the entire OBW of the spectrum.
- j) Add 10 log (1/duty cycle) to the measured power level to compute the average power during continuous transmission.

Note:

- 1) Test distance is determined to 3.5 m by far field condition; see test descriptions on page 8.
- 2) In this test, EUT is operated only measurement path is turned on and path has straight beamforming.
- 3) For 8 cc measurement, test is performed for all carriers of 100 MHz bandwidth, but recorded only maximum output level.
- 4) The angle of antenna is set as maximum radiated power conditions.
- 5) EIRP is calculated from measured value according to section 5.2.7 of ANSI C62.26-2015, and the formula is as follows.

$$\begin{aligned} EIRP (dBm) &= E (dB\mu V/m) + 20\log(3.5 m) - 104.77 \\ &= E (dB\mu V/m) - 93.89 \end{aligned}$$

- 6) E (dB μ V/m) value is considered AFCL and Duty cycle factor and it as follow.

$$\begin{aligned} E \text{ (dB}\mu\text{V/m)} &= \text{measurement value (dB}\mu\text{V)} + \text{AFCL (28 GHz)} + \text{Duty cycle correction (80 \%)} \\ &= \text{measurement value (dB}\mu\text{V)} + 45.44 + 0.975 \end{aligned}$$

- 7) According to section 6.4 of ANSI C63.26-2015, MIMO EIRP is calculated by co-polarized antenna arrays (A and C / B and D). Total MIMO EIRP is calculated by correlated signals(A and C and B and D)
- 8) The output tolerance of the EUT in the specification is ± 3 dB and test result satisfies this condition.
- 9) Sample calculation:

$$\begin{aligned} 95.51 \text{ dB}\mu\text{V (measured Value)} + 10.88 \text{ (distance)} - 104.77 + 45.44 \text{ (AFCL)} + 0.975 \text{ (Duty)} \\ = 48.04 \text{ dBm (Final EIRP)} \end{aligned}$$

Test Results:

Tabular Data of EIRP Density per path

Ant.	Ant.	CC	Channel	Frequency (GHz)	Mod.	Measured Level	Limit (dBm)	Calculated EIRP (dBm)			
	Angle					(dBuV)					
A	135°	1	Low	27.55	QPSK	95.51	75	48.04			
					16QAM	95.60		48.13			
					64QAM	95.38		47.91			
			Middle	27.925	QPSK	95.42		47.95			
					16QAM	95.54		48.07			
					64QAM	94.69		47.22			
			High	28.3	QPSK	95.03		47.56			
					16QAM	95.16		47.69			
					64QAM	95.13		47.66			
		8	Low	27.9	QPSK	94.22		46.75			
					16QAM	94.48		47.01			
					64QAM	94.12		46.65			
			Middle	27.925	QPSK	93.40		45.93			
					16QAM	93.78		46.31			
					64QAM	93.84		46.37			
			High	27.95	QPSK	93.16		45.69			
					16QAM	93.69		46.22			
					64QAM	93.66		46.19			
		B	45°	1	Low	27.55		QPSK	94.58	75	47.12
								16QAM	95.65		48.18
								64QAM	95.66		48.19
					Middle	27.925		QPSK	95.14		47.67
								16QAM	95.11		47.64
								64QAM	95.64		48.17
High	28.3				QPSK	94.83	47.36				
					16QAM	95.58	48.11				
					64QAM	95.25	47.78				
8	Low			27.9	QPSK	93.16	45.69				
					16QAM	92.82	45.35				
					64QAM	93.94	46.47				
	Middle			27.925	QPSK	93.69	46.22				
					16QAM	93.88	46.41				
					64QAM	93.76	46.29				
	High			27.95	QPSK	93.16	45.69				
					16QAM	93.31	45.84				
					64QAM	93.89	46.42				

Ant.	Ant.	CC	Channel	Frequency (GHz)	Mod.	Measured Level	Limit (dBm)	Calculated EIRP (dBm)			
	Angle					(dBuV)					
C	135°	1	Low	27.55	QPSK	95.44	75	47.97			
					16QAM	94.60		47.14			
					64QAM	95.06		47.59			
			Middle	27.925	QPSK	95.17		47.70			
					16QAM	94.80		47.33			
					64QAM	95.27		47.81			
			High	28.3	QPSK	93.99		46.53			
					16QAM	94.22		46.75			
					64QAM	94.31		46.84			
		8	Low	27.9	QPSK	93.60		46.13			
					16QAM	92.81		45.34			
					64QAM	92.90		45.43			
			Middle	27.925	QPSK	93.34		45.87			
					16QAM	93.74		46.27			
					64QAM	93.56		46.09			
			High	27.95	QPSK	92.96		45.49			
					16QAM	93.37		45.90			
					64QAM	93.74		46.27			
		D	45°	1	Low	27.55		QPSK	93.45	75	45.98
								16QAM	94.36		46.90
								64QAM	94.00		46.53
					Middle	27.925		QPSK	95.36		47.89
								16QAM	95.51		48.04
								64QAM	94.99		47.52
High	28.3				QPSK	94.25	46.78				
					16QAM	94.42	46.95				
					64QAM	94.43	46.96				
8	Low			27.9	QPSK	93.44	45.97				
					16QAM	93.35	45.88				
					64QAM	93.33	45.86				
	Middle			27.925	QPSK	93.70	46.23				
					16QAM	93.67	46.20				
					64QAM	93.81	46.35				
	High			27.95	QPSK	92.98	45.51				
					16QAM	93.45	45.98				
					64QAM	93.45	45.98				

Tabular Data of EIRP Density for MIMO

Ant.	CC	Ch.	Mod.	Ant A EIRP (dBm)	Ant C EIRP (dBm)	Limit (dBm)	Calculated EIRP (dBm)	
A+C	1	Low	QPSK	48.04	47.97	75	51.02	
			16QAM	48.13	47.14		50.67	
			64QAM	47.91	47.59		50.76	
		Middle	QPSK	47.95	47.70		50.84	
			16QAM	48.07	47.33		50.73	
			64QAM	47.22	47.81		50.54	
		High	QPSK	47.56	46.53		50.09	
			16QAM	47.69	46.75		50.26	
			64QAM	47.66	46.84		50.28	
		8	Low	QPSK	46.75		46.13	49.46
				16QAM	47.01		45.34	49.27
				64QAM	46.65		45.43	49.09
	Middle		QPSK	45.93	45.87		48.91	
			16QAM	46.31	46.27		49.30	
			64QAM	46.37	46.09		49.24	
	High		QPSK	45.69	45.49		48.60	
			16QAM	46.22	45.90		49.07	
			64QAM	46.19	46.27		49.24	

Ant.	CC	Ch.	Mod.	Ant B EIRP (dBm)	Ant D EIRP (dBm)	Limit (dBm)	Calculated EIRP (dBm)	
B+D	1	Low	QPSK	47.12	45.98	75	49.60	
			16QAM	48.18	46.90		50.60	
			64QAM	48.19	46.53		50.45	
		Middle	QPSK	47.67	47.89		50.79	
			16QAM	47.64	48.04		50.85	
			64QAM	48.17	47.52		50.87	
		High	QPSK	47.36	46.78		50.09	
			16QAM	48.11	46.95		50.58	
			64QAM	47.78	46.96		50.40	
		8	Low	QPSK	45.69		45.97	48.84
				16QAM	45.35		45.88	48.63
				64QAM	46.47		45.86	49.19
	Middle		QPSK	46.22	46.23		49.24	
			16QAM	46.41	46.20		49.32	
			64QAM	46.29	46.35		49.33	
	High		QPSK	45.69	45.51		48.61	
			16QAM	45.84	45.98		48.92	
			64QAM	46.42	45.98		49.22	

Ant.	CC	Ch.	Mod.	Ant. A (dBm)	Ant. B (dBm)	Ant. C (dBm)	Ant. D (dBm)	Limit (dBm)	Calculated EIRP (dBm)	
A+B+C+D	1	Low	QPSK	48.04	47.12	47.97	45.98	75	53.37	
			16QAM	48.13	48.18	47.14	46.9		53.65	
			64QAM	47.91	48.19	47.59	46.53		53.62	
		Middle	QPSK	47.95	47.67	47.7	47.89		53.82	
			16QAM	48.07	47.64	47.33	48.04		53.80	
			64QAM	47.22	48.17	47.81	47.52		53.71	
		High	QPSK	47.56	47.36	46.53	46.78		53.10	
			16QAM	47.69	48.11	46.75	46.95		53.43	
			64QAM	47.66	47.78	46.84	46.96		53.35	
		8	Low	QPSK	46.75	45.69	46.13		45.97	52.17
				16QAM	47.01	45.35	45.34		45.88	51.97
				64QAM	46.65	46.47	45.43		45.86	52.15
	Middle		QPSK	45.93	46.22	45.87	46.23		52.09	
			16QAM	46.31	46.41	46.27	46.2		52.32	
			64QAM	46.37	46.29	46.09	46.35		52.30	
	High		QPSK	45.69	45.69	45.49	45.51		51.62	
			16QAM	46.22	45.84	45.9	45.98		52.01	
			64QAM	46.19	46.42	46.27	45.98		52.24	

Note : A and C / B and D is cross pol. and correlated signals.