

FCC TEST REPORT

Reference No. : G-45-2016-03552
Applicant : Samsung Electronics Co., Ltd.
Equipment Under Test (EUT) :
 Product Name : Wireless Dongle
 Model Name : AA-RR1D9TG

Applied Standards : FCC Part 15 Subpart B
 ANSI C 63.4:2014

FCC ID : A3LAARR1D9TG

Date of Receipt : October 28, 2016
Date of Test : November 14, 2016
Date of Issue : November 23, 2016
Test Results : Complied

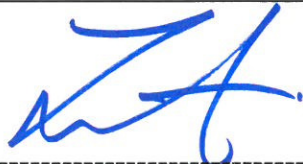
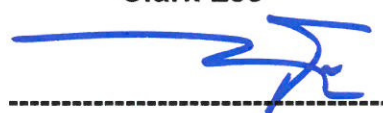
Tested by :	 ----- Clark Lee
Reviewed by :	 ----- Paul Kang

Remarks :

This document is issued by the Company subject to its General Conditions of Service printed overleaf, available on request or accessible at <http://www.sgs.com/en/Terms-and-Conditions.aspx> and, for electronic format documents, subject to Terms and Conditions for Electronic Documents at www.sgs.com/terms_e-document.htm. The results shown in this test report refer only to the sample(s) tested unless otherwise stated. This Test Report cannot be reproduced, except in full

Contents

1. General Information.....	3
1.1 Client Information.....	3
1.2 Test Laboratory.....	3
1.3 General Information of E.U.T.	3
1.4 Operating Modes and Conditions.....	3
1.4.1 Monitoring Method	3
1.5 Auxiliary Equipments	4
1.6 Cable List.....	4
1.7 System Configurations.....	5
1.8 Test System Layout	5
1.9 Modifications.....	5
1.10 Applicable Standards for Testing	5
1.11 Summary of Test Results.....	5
2. Emission Test.....	6
2.1 Test Results.....	6
2.2 Test Method and Limits.....	6
2.2.1 Test Method	6
2.2.2 Test Limits.....	6
2.3 Conducted Emission	7
2.3.1 Test Equipments	7
2.3.2 Test Site.....	7
2.3.3 Environment Conditions and data	7
2.4 Radiated Emission	9
2.4.1 Test Equipments	9
2.4.2 Test Site.....	9
2.4.3 Environment Conditions and data	9
Appendix A : Conducted Emission at Mains Port	12
Appendix B : Radiated Emission	13

1. General Information

1.1 Client Information

Applicant : Samsung Electronics Co., Ltd.
 Address of Applicant : 129, Samsung-ro, Yeongtong-gu, Suwon-si, Gyeonggi-do, Republic of Korea

Manufacturer : Samsung Electronics Co., Ltd.
 Address of Manufacturer : 99.Zhu Yuan Road, New District Suzhou, China

1.2 Test Laboratory

Name and Address : SGS Korea Co., Ltd.
 Giheung 1 Laboratory : 35, Giheungdanji-ro 121beon-gil, Giheung-gu, Yongin-si, Gyeonggi-do, Republic of Korea
 Giheung 2 Laboratory : 23, Giheungdanji-ro 24beon-gil, Giheung-gu, Yongin-si, Gyeonggi-do, Republic of Korea
 Gunpo Laboratory : 4, LS-ro 182beon-gil, Gunpo-si, Gyeonggi-do, 435-040 Republic of Korea

Phone : + 82 31 428 5700
 Fax : + 82 31 427 2370
 e-mail : Paul.Kang@sgs.com

1.3 General Information of E.U.T.

Product Name	Wireless Dongle
Model Name	AA-RR1D9TG
Serial No.	-
EMI Classification	Class B
Internal Clock Frequency	2475 MHz
Test Voltage	120 V~, 60 Hz (for Notebook Computer).
FCC ID	A3LAARR1D9TG

1.4 Operating Modes and Conditions

Operating mode	Operating condition
Communication Mode	Communication Status between a Dongle connected to a notebook and a Wireless Keyboard / Wireless Mouse

1.4.1 Monitoring Method

- Communication Status was monitored by using the notebook computer and EUT's LED.

1.5 Auxiliary Equipments

Description	Model	Serial No.	Manufacturer
Wireless Keyboard	AA-KR1D9TG	CNBA9607124ADX LR69P0189	Samsung Electronics Co., Ltd.
Wireless Mouse	AA-MR1D9TG	CNBA8201010CBI H46AS0109	Samsung Electronics Co., Ltd.
Wireless Dongle	AA-RR1D9TG	-	Samsung Electronics Co., Ltd.
AC/DC ADPATER(LCD)	ADP-40DD B	-	DELTA ELECTRONICS, INC.
LCD MONITOR	S2740Lb	-	DELL INC.
Wireless Router	WG602	1PA11C5000896	NETGEAR
I.T.E. POWER SUPPLY	MU08A9075100- C5	332-10309-01	NETGEAR
Notebook Computer	LGE- DMLGX14(B)	008QTEQ024836	LG Electronics Co., Ltd.
AC/DC ADPATER(NOTEBOOK)	ADP-40PH AD	-	DELTA ELECTRONICS, INC.
USB KEYBOARD	SKS-9000UB	-	MONTEREY INTERNATION CORP.
USB MOUSE	1344	-	Microsoft

1.6 Cable List

Start		END		Cable Spec.		Used core
Name	I/O Port	Name	I/O Port	Length	Shield	
EUT	USB	NOTEBOOK COMPUTER	USB	-	-	-
NOTEBOOK COMPUTER	USB	USB KEYBOARD	USB	1.5	Unshield	No.
	USB	USB MOUSE	USB	0.8	Unshield	No.
	RGB	LCD MONITOR	RGB	1.8	Unshield	No.
	LAN	WIRELESS ROUTER	LAN	3.5	Unshield	No.
	DC IN	AC/DC ADAPTER (NOTEBOOK)	DC OUT	1.2	Unshield	No.
LCD MONITOR	DC IN	AC/DC ADAPTER (LCD)	DC OUT	1.5	Unshield	No.
WIRELESS ROUTER	DC IN	I.T.E. POWER SUPPLY	DC OUT	1.5	Unshield	No.
AC/DC ADAPTER (NOTEBOOK)	AC IN	AC SOURCE	AC OUT	1.2	Unshield	No.
AC/DC ADAPTER (LCD)	AC IN		AC OUT	1.2	Unshield	No.
I.T.E. POWER SUPPLY	AC IN		AC OUT	1.2	Unshield	No.

Note : Our computers have only three types of ports, so we can't connect other type peripherals.

1.7 System Configurations

Description	Model	Serial No.	Manufacturer
MainBoard	AA-RR1D9TG	-	-

1.8 Test System Layout

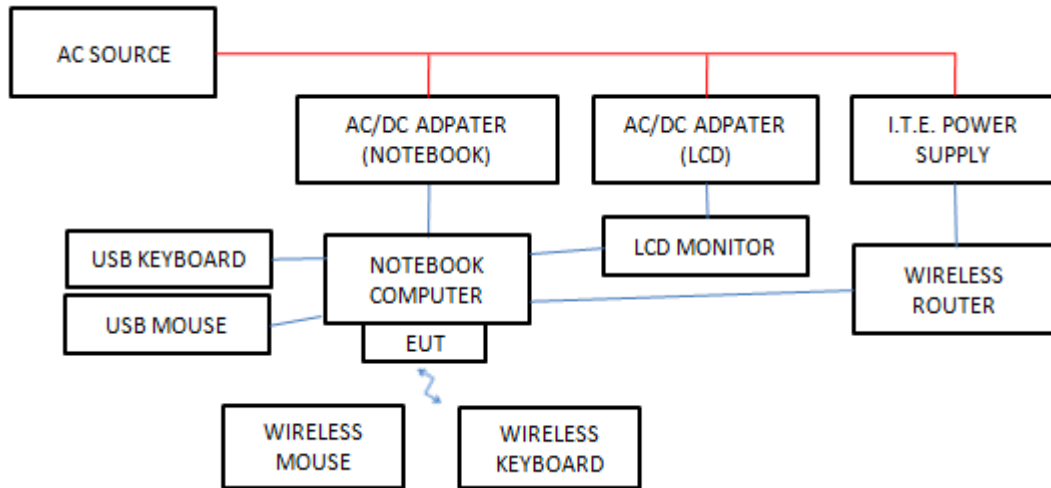

1.9 Modifications

There was no modified item during the test.

1.10 Applicable Standards for Testing

Standards	Status	Deviation
FCC Part 15 Subpart B	Applicable	No Deviation

1.11 Summary of Test Results

Test Item	Basic Standards	Results
Conducted Emission	ANSI C 63.4:2014 FCC Part 15 Subpart B	Complied
Radiated Emission	ANSI C 63.4:2014 FCC Part 15 Subpart B	Complied

Note: Test methods of all test items are performed according to the basic standards in this table.

EMISSION

2.1 Test Results

Test Items	Basic Standards	Test Results
Conducted Emission	ANSI C 63.4:2014 FCC Part 15 Subpart B	Complied
Radiated Emission	ANSI C 63.4:2014 FCC Part 15 Subpart B	Complied

2.2 Test Method and Limits

2.2.1 Test Method

Test Items	Measuring Frequency Range	RBW	Measuring Distance
Conducted Emission	0.15 MHz ~ 30 MHz	9 kHz	-
Radiated Emission	30 MHz ~ 1 GHz	120 kHz	10 m & 3 m
	Above 1 GHz	1 MHz	3 m

2.2.2 Test Limits

-Conducted Emission Limits at Mains Port

Frequency Range	Limits(dB(μ V))		Class
	Quasi-peak	Average	
0.15 MHz ~ 0.5 MHz	79	66	Class A
0.5 MHz ~ 30 MHz	73	60	
0.15 MHz ~ 0.5 MHz	66 to 56	56 to 46	Class B
0.5 MHz ~ 5 MHz	56	46	
5 MHz ~ 30 MHz	60	50	

Note : The lower limit shall apply at the transition frequencies. The limit decreases linearly with the logarithm of the frequency in the range 0.15 MHz to 0.5 MHz.

-Radiated Emission Limits below 1 GHz

Frequency Range	Limits(dB(μ V/m))	Class
	Quasi-peak	
30 MHz ~ 88 MHz	39.1	Class A
88 MHz ~ 216 MHz	43.5	
216 MHz ~ 960 MHz	46.4	
960 MHz ~ 1 GHz	49.5	
30 MHz ~ 88 MHz	40	Class B
88 MHz ~ 216 MHz	43.5	
216 MHz ~ 960 MHz	46	
960 MHz ~ 1 GHz	54	

-Radiated Emission Limits above 1 GHz (3m method)

Frequency Range	Limits(dB(μ V/m))		Class
	Average	Peak	
Above 1 GHz	59.5	79.5	Class A
Above 1 GHz	54	74	Class B

2.3 Conducted Emission

The initial preliminary exploratory scans were performed over the measuring frequency range(0.15 MHz to 30 MHz) using a max hold mode incorporating a Peak detector and Average detector and using the software of ES-K1(Version V1.71 from R&S). The final test data was measured using a Quasi-Peak detector and Average detector.

2.3.1 Test Equipments

Description	Model No.	Manufacturer	S/N	Cal Due. Date
Two-Line V-Network	ENV216	R & S	100190	2016.12.21
Test Receiver	ESCI 7	R & S	100911	2016.12.22

Note : The calibration period of every equipment is 1 year.

2.3.2 Test Site

Shield Room in Gunpo Laboratory

2.3.3 Environment Conditions and data

- Conducted Emission at AC Mains Port

Temp. (Minimum 25.1 °C, Maximum 25.5 °C) ,
 Humidity (Minimum 46.0 % R.H., Maximum 46.0 % R.H.)
 Atmospheric Pressure : (104.3) kPa

Test Date : November 14, 2016

Freq. (MHz)	Line (H/N)	Level (dB μ V)		CL (dB)	LISN (dB)	Result (dB μ V)		Limit (dB μ V)		Margin (dB)	
		Q/P	A/V			Q/P	A/V	Q/P	A/V	Q/P	A/V
0.19	N	29.38	11.08	0.02	9.70	39.10	20.80	63.95	53.95	24.85	33.15
0.19	H	32.78	14.88	0.02	9.60	42.40	24.50	63.93	53.93	21.53	29.43
0.31	N	18.48	11.58	0.02	9.70	28.20	21.30	59.89	49.89	31.69	28.59
0.31	H	23.18	8.38	0.02	9.60	32.80	18.00	59.88	49.88	27.08	31.88
0.48	H	33.49	24.09	0.01	9.60	43.10	33.70	56.30	46.30	13.20	12.60
0.48	N	33.09	23.59	0.01	9.70	42.80	33.30	56.30	46.30	13.50	13.00
1.90	H	15.54	4.24	0.06	9.60	25.20	13.90	56.00	46.00	30.80	32.10
3.72	N	9.29	2.09	0.11	9.70	19.10	11.90	56.00	46.00	36.90	34.10
8.70	H	14.37	7.17	0.17	9.66	24.20	17.00	60.00	50.00	35.80	33.00
8.97	N	13.16	7.96	0.17	9.77	23.10	17.90	60.00	50.00	36.90	32.10
21.36	H	14.19	9.39	0.21	9.70	24.10	19.30	60.00	50.00	35.90	30.70
21.59	N	14.57	9.77	0.21	9.92	24.70	19.90	60.00	50.00	35.30	30.10

Measurement Uncertainty : 2.98 dB (The confidential level is about 95%, $k=2$)

- Note :
- Line (H) : Hot
 - Line (N) : Neutral
 - CL: Cable Loss
 - LISN : LISN Factor
 - Result = Level + CL + LISN
 - Margin = Limit – Result

See Appendix A (Conducted Emission at AC Mains Port)

2.4 Radiated Emission

The initial preliminary exploratory scans were performed at 3 m distance over the measuring frequency range(30 MHz to 26 GHz) using a max hold mode incorporating a Peak detector and using the software of EMC32(Version 8.50.0 from R&S) and EP5RE(Version Ver3.10.20 from TOYO). The final test data was measured using a Quasi-Peak detector below 1 GHz at 10 m distance and a Peak and Average detector above 1 GHz at 3 m distance. Measurements were made with the antenna positioned in both the horizontal and vertical planes of polarization. The antenna height was varied from 1 m to 4 m and the EUT was rotated 360° to find the maximum emitting point for each frequency.

2.4.1 Test Equipments

Description	Model No.	Manufacturer	S/N	Cal Due. Date
Horn Antenna (RRA)	HF906	R & S	100326	2017.04.16
Horn Antenna (RRA)	BBHA9170	SCHWARZBECK MESS- ELEKTRONIK	BBHA9170540	2017.09.04
Signal Conditioning Unit	SCU 18	R & S	10117	2017.04.07
Test Receiver	ESU26	R & S	100109	2017.03.07
Bilog Antenna (RRA)	VULB9163	SCHWARZBECK MESS- ELEKTRONIK	396	2018.06.22
PREAMPLIFIER	JS44-18004000- 35-8P	MITEQINC	1546891	2017.05.12
Amplifier	8447F	HP	2944A03909	2017.08.11

Note : Only the calibration period of Antennas is 2 years but the period of every equipment is 1 year.

2.4.2 Test Site

3m SEMI-ANECHOIC CHAMBER Gunpo Laboratory (Below 1 GHz, Above 1 GHz)

2.4.3 Environment Conditions and data

- Below 1 GHz

Temperature : (minimum 23.3, maximum 23.6) °C

Humidity : (minimum 41.0, maximum 41.0) %R.H.

Atmospheric Pressure : (103.0) kPa

Test Date : November 14, 2016

- Above 1 GHz

Temperature : (minimum 23.3, maximum 23.6) °C
 Humidity : (minimum 41.0, maximum 41.0) %R.H.
 Atmospheric Pressure : (103.0) kPa

Test Date : November 14, 2016

- Below 1 GHz (3 m method)

Freq. (MHz)	Level (dB(μV))	Pol. (H/V)	A (°)	H (cm)	AF (dB/m)	CL (dB)	Amp. (dB)	Result (dB(μV/m))	Limit (dB(μV/m))	Margin (dB)
54.49	20.20	V	267	100	13.35	0.86	27.90	6.51	40.00	33.49
146.20	39.80	V	252	100	8.25	1.41	27.34	22.12	43.50	21.38
164.87	24.20	V	301	200	8.52	1.51	27.60	6.63	43.50	36.87
283.74	27.40	H	229	100	13.54	1.94	27.40	15.48	46.00	30.52
297.28	31.00	H	218	100	13.87	2.05	27.40	19.52	46.00	26.48
303.70	29.00	H	102	400	14.02	2.05	27.20	17.87	46.00	28.13

Measurement Uncertainty (Horizontal) : 4.82 dB (The confidential level is about 95%, k=2)

Measurement Uncertainty (Vertical) : 5.34 dB (The confidential level is about 95%, k=2)

Note 1: • AF = Antenna Factor
 • POL H = Horizontal
 • H : Height

• CL = Cable Loss

• POL V = Vertical

• Margin = Limit – Result

• Amp = Amplifier Gain

• A : Angle

• Result = Level + AF + CL – Amp

- Above 1 GHz (3 m method)

(1 GHz ~18 GHz)

Freq. (MHz)	Level (dB μ V)	Pol. (H/V)	A (°)	H (cm)	AF (dB)	CL (dB)	Amp. (dB)	CF (dB)	F/S (dB μ V/m)	Limit (dB μ V/m)	Margin (dB)
Peak Detector											
1345.67	31.80	H	190	100	24.69	4.04	37.47	0.00	23.06	74.00	50.94
1449.79	33.60	V	215	100	24.92	4.18	37.55	0.00	25.15	74.00	48.85
14875.54	29.00	H	182	100	40.45	16.01	37.39	0.00	48.07	74.00	25.93
16107.33	29.10	V	170	100	40.67	15.60	37.88	0.00	47.49	74.00	26.51
17748.54	32.70	H	107	100	43.00	16.46	39.77	0.00	52.39	74.00	21.61
17948.29	32.70	V	294	100	43.32	16.75	39.87	0.00	52.90	74.00	21.10
Average Detector											
1345.67	23.00	H	190	100	24.69	4.04	37.47	0.00	14.26	54.00	39.74
1449.79	24.80	V	215	100	24.92	4.18	37.55	0.00	16.35	54.00	37.65
14875.54	23.80	H	182	100	40.45	16.01	37.39	0.00	42.87	54.00	11.13
16107.33	20.50	V	170	100	40.67	15.60	37.88	0.00	38.89	54.00	15.11
17748.54	21.10	H	107	100	43.00	16.46	39.77	0.00	40.79	54.00	13.21
17948.29	20.10	V	294	100	43.32	16.75	39.87	0.00	40.30	54.00	13.70

(18 GHz ~26 GHz)

Freq. (MHz)	Level (dB μ V)	Pol. (H/V)	A (°)	H (cm)	AF (dB)	CL (dB)	Amp. (dB)	CF (dB)	F/S (dB μ V/m)	Limit (dB μ V/m)	Margin (dB)
Peak Detector											
23407.66	45.00	V	184	100	39.62	3.71	52.59	0.00	35.74	74.00	38.26
23447.66	44.70	H	134	100	39.60	3.71	52.59	0.00	35.42	74.00	38.58
25342.66	45.20	V	313	100	39.64	3.71	52.17	0.00	36.38	74.00	37.62
25511.33	45.50	H	110	100	39.61	3.71	52.06	0.00	36.76	74.00	37.24
Average Detector											
23407.66	33.10	V	184	100	39.62	3.71	52.59	0.00	23.84	54.00	30.16
23447.66	34.80	H	134	100	39.60	3.71	52.59	0.00	25.52	54.00	28.48
25342.66	34.50	V	313	100	39.64	3.71	52.17	0.00	25.68	54.00	28.32
25511.33	35.10	H	110	100	39.61	3.71	52.06	0.00	26.36	54.00	27.64

Measurement Uncertainty (Horizontal) : 5.78 dB (The confidential level is about 95%, $k=2$)

Measurement Uncertainty (Vertical) : 5.90 dB (The confidential level is about 95%, $k=2$)

Note 1: • AF = Antenna Factor

• CL = Cable Loss

• Amp = Amplifier Gain

• POL H = Horizontal

• POL V = Vertical

• A : Angle

• H : Height

• Margin = Limit – Result

• Result = Level + AF + CL – Amp

See Appendix B (Radiated Emission)

Appendix A : Conducted Emission at Mains Port

Hot

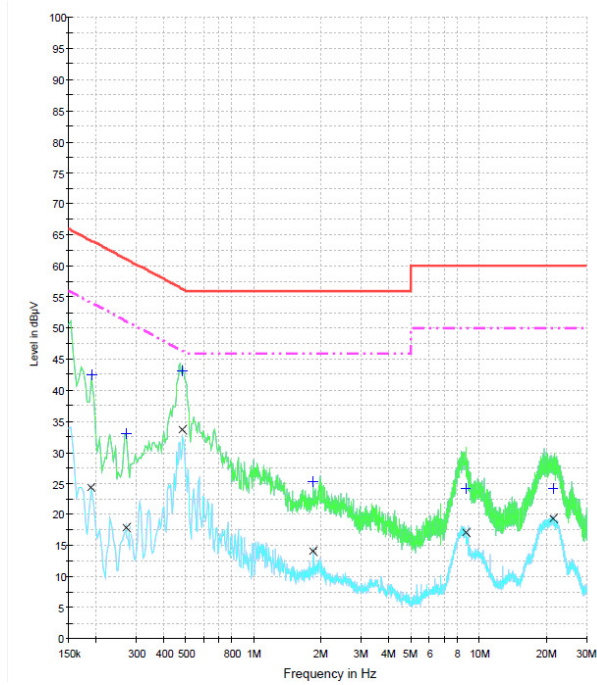

Neutral

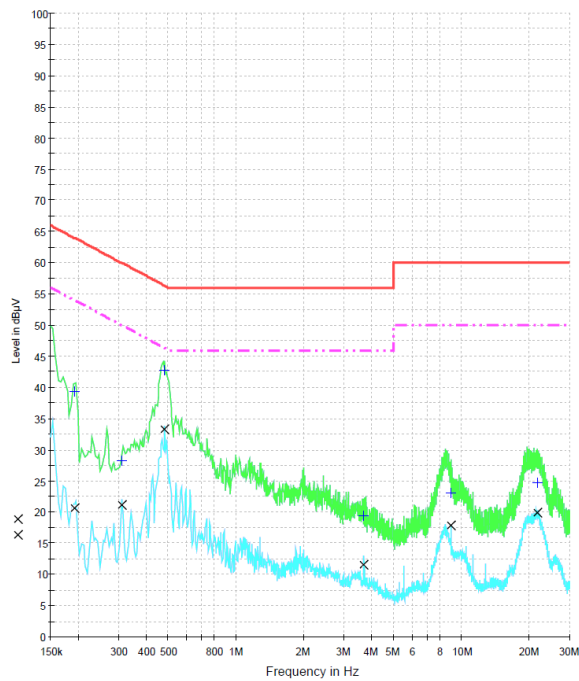

Appendix B : Radiated Emission

Below 1 GHz

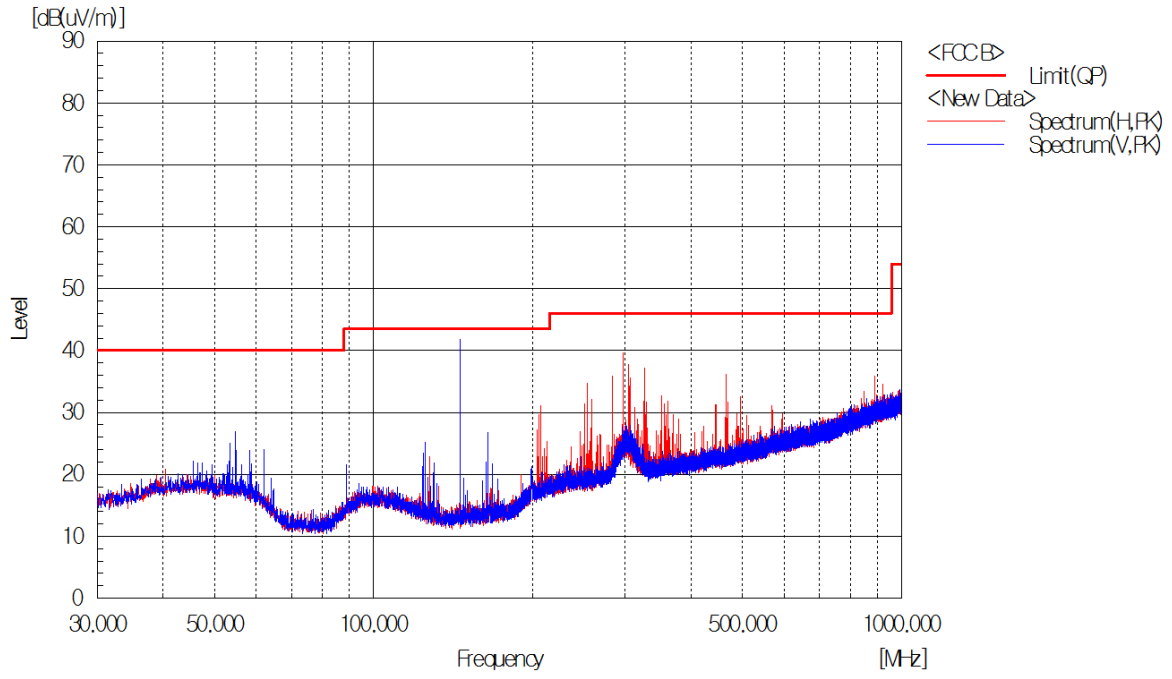

Above 1 GHz
(1 GHz ~18 GHz)

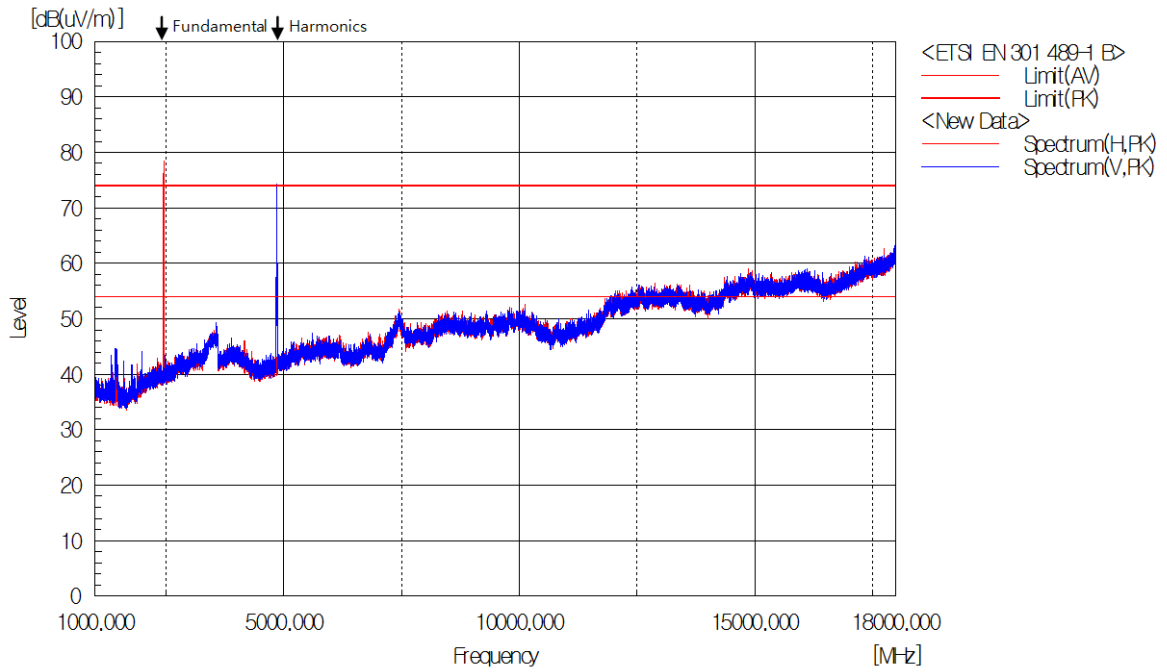

(18 GHz ~26 GHz)

