

TEST REPORT

Report Number: 19071647HKG-003R1

Application for Original Grant of 47 CFR Part 15 Certification

This report contains the data of 5GHz WLAN (WiFi) portion only.

FCC ID: A2HWT9L11

This report supersedes previous report with report number 19071647HKG-003 dated September 20, 2019.
Please refer HEE-S19-0043 Letter issued on November 05, 2019 for amendment/ supersede notification.

Tested, Prepared and Checked by:

Approved by:



Kelvin Liang
Assistant Manager
Shenzhen UnionTrust Quality and
Technology Co., Ltd.

Lee Shui Tim, Tim
Senior Lead Engineer
Intertek Testing Services Hong Kong
Date: November 05, 2019

Intertek's standard Terms and Conditions can be obtained at our website <http://www.intertek.com/terms/>.

The test report only allows to be revised within the retention period unless further standard or the requirement was noticed.

This report is for the exclusive use of Intertek's Client and is provided pursuant to the agreement between Intertek and its Client. Intertek's responsibility and liability are limited to the terms and conditions of the agreement. Intertek assumes no liability to any party, other than to the Client in accordance with the agreement, for any loss, expense or damage occasioned by the use of this report. Only the Client is authorized to permit copying or distribution of this report and then only in its entirety. Any use of the Intertek name or one of its marks for the sale or advertisement of the tested material, product or service must first be approved in writing by Intertek. The observations and test results in this report are relevant only to the sample tested. This report by itself does not imply that the material, product, or service is or has ever been under an Intertek certification program.

© 2017 Intertek

TEST REPORT

GENERAL INFORMATION

Applicant Name:	Alco Electronics Ltd.
Applicant Address:	11/F., Metropole Square, 2 On Yiu Street, Sha Tin, N.T., Hong Kong.
FCC Specification Standard:	FCC Part 15, October 1, 2017 Edition
FCC ID:	A2HWT9L11
FCC Model(s):	WT9L11P44GD51, 100005693
Type of EUT:	Unlicensed National Information Infrastructure Transmitter
Description of EUT:	Tablet
Serial Number:	N/A
Sample Receipt Date:	July 31, 2019
Date of Test:	August 23, 2019 to September 10, 2019
Report Date:	November 05, 2019
Environmental Conditions:	Temperature: +10 to 40°C Humidity: 10 to 90%
Conclusion:	Test was conducted by client submitted sample. The submitted sample as received complied with the 47 CFR Part Certification.

TEST REPORT

TABLE OF CONTENTS

1.0 TEST RESULTS SUMMARY & STATEMENT OF COMPLIANCE 4

 1.1 Summary of Test Results4

 1.2 Statement of Compliance4

2.0 GENERAL DESCRIPTION..... 5

 2.1 Product Description.....5

 2.2 Test Methodology8

 2.3 Test Facility8

 2.4 Related Submittal(s) Grants.....8

3.0 SYSTEM TEST CONFIGURATION..... 9

 3.1 Justification9

 3.2 EUT Exercising Software10

 3.3 Details of EUT and Description of Accessories.....11

 3.4 Measurement Uncertainty11

4.0 TEST RESULTS 12

 4.1 Maximum Conducted Output Power at Antenna Terminals.....12

 4.2 Minimum 6dB RF Bandwidth19

 4.3 26 dB Bandwidth & Occupied Bandwidth21

 4.4 Maximum Power Spectral Density.....23

 4.5 Field Strength Calculation.....29

 4.6 Transmitter Radiated Emissions in Restricted Bands and Spurious Emissions.....30

 4.6.1 Radiated Emission Configuration Photograph30

 4.6.2 Radiated Emission Data30

 4.6.3 Radiated Emission Test Setup151

 4.6.4 Transmitter Duty Cycle Calculation (Ant.1)152

 4.6.5 Transmitter Duty Cycle Calculation (Ant.2)155

 4.7 AC Power Line Conducted Emission.....158

 4.7.1 AC Power Line Conducted Emission Configuration Photograph158

 4.7.2 AC Power Line Conducted Emission Data.....158

 4.7.3 Conducted Emission Test Setup161

 4.8 DFS Channel Shutdown and Non-occupancy period162

5.0 EQUIPMENT LIST 179

TEST REPORT

1.0 TEST RESULTS SUMMARY & STATEMENT OF COMPLIANCE

1.1 Summary of Test Results

Test Items	FCC Part 15 Section	Results	Details See Section
Antenna Requirement	15.407(a)	Pass	2.1
Max. Conducted Output Power (Peak)	15.407(a)	Pass	4.1
Transmit Power Control (TPC)	15.407(h)	N/A	See Remark
Min. 6dB RF Bandwidth	15.407(e)	Pass	4.2
26 dB emission bandwidth	15.407(a)	Pass	4.3
Occupied Bandwidth	N/A	Pass	4.3
Max. Power Density (average)	15.407(a)	Pass	4.4
Radiated Emission in Restricted Bands and Spurious Emissions	15.407(b), 15.209 & 15.109	Pass	4.5
AC Power Line Conducted Emission	15.207 & 15.107	Pass	4.7
Dynamic Frequency Selection(DFS)	15.407	Pass	4.8

Remark: Not applicable if the EUT is <500mW (27dBm)

Note: Pursuant to FCC Part 15 Section 15.215(c), the 20dB bandwidth of the emission was contained within the frequency band designated (mentioned as above) which the EUT operated. The effects, if any, from frequency sweeping, frequency hopping, other modulation techniques and frequency stability over expected variations in temperature and supply voltage were considered.

1.2 Statement of Compliance

The equipment under test is found to be complying with the following standard:

FCC Part 15, October 1, 2017 Edition

TEST REPORT

2.0 GENERAL DESCRIPTION

2.1 Product Description

The Tablet (WT9L11P44GD51) is a Law enforcement recorder. It is the with Wireless Wi-Fi (802.11a/ac/b/g/n) connectivity, Bluetooth connectivity.

For the WLAN (WiFi) module:

For 5.15-5.25GHz:

For 802.11a mode, it operates at frequency range of 5180.00MHz to 5240.000MHz with 4 channels. It transmits via Orthogonal Frequency Division Multiplexing (OFDM) modulation. Maximum bit rate can be up to 54Mbps.

For 802.11n (with 20MHz bandwidth) mode, it operates at frequency range of 5180.00MHz to 5240.000MHz with 4 channels. It transmits via Orthogonal Frequency Division Multiplexing (OFDM) modulation. Maximum bit rate can support up to 65.0Mbps.

For 802.11n (with 40MHz bandwidth) mode, it operates at frequency range of 5190.00MHz to 5230.000MHz with 2 channels. It transmits via Orthogonal Frequency Division Multiplexing (OFDM) modulation. Maximum bit rate can support up to 135.0Mbps.

For 802.11ac (with 20MHz bandwidth) mode, it operates at frequency range of 5180.00MHz to 5240.000MHz with 4 channels. It transmits via Orthogonal Frequency Division Multiplexing (OFDM) modulation. Maximum bit rate can support up to 86.7Mbps.

For 802.11ac (with 40MHz bandwidth) mode, it operates at frequency range of 5190.00MHz to 5230.000MHz with 2 channels. It transmits via Orthogonal Frequency Division Multiplexing (OFDM) modulation. Maximum bit rate can support up to 180Mbps.

For 802.11ac (with 80MHz bandwidth) mode, it operates at frequency 5210MHz. It transmits via Orthogonal Frequency Division Multiplexing (OFDM) modulation. Maximum bit rate can support up to 390Mbps.

For 5.25-5.35GHz:

For 802.11a mode, it operates at frequency range of 5260.00MHz to 5320.000MHz with 4 channels. It transmits via Orthogonal Frequency Division Multiplexing (OFDM) modulation. Maximum bit rate can be up to 54Mbps.

For 802.11n (with 20MHz bandwidth) mode, it operates at frequency range of 5260MHz to 5320MHz with 4 channels. It transmits via Orthogonal Frequency Division Multiplexing (OFDM) modulation. Maximum bit rate can support up to 65Mbps.

For 802.11n (with 40MHz bandwidth) mode, it operates at frequency range of 5270.00MHz to 5310.000MHz with 2 channels. It transmits via Orthogonal Frequency Division Multiplexing (OFDM) modulation. Maximum bit rate can support up to 135Mbps.

For 802.11ac (with 20MHz bandwidth) mode, it operates at frequency range of 5260MHz to 5320MHz with 4 channels. It transmits via Orthogonal Frequency Division Multiplexing (OFDM) modulation. Maximum bit rate can support up to 86.7Mbps.

For 802.11ac (with 40MHz bandwidth) mode, it operates at frequency range of 5270.00MHz to 5310.000MHz with 2 channels. It transmits via Orthogonal Frequency Division Multiplexing (OFDM) modulation. Maximum bit rate can support up to 180Mbps.

TEST REPORT

For 802.11ac (with 80MHz bandwidth) mode, it operates at frequency 5290MHz. It transmits via Orthogonal Frequency Division Multiplexing (OFDM) modulation. Maximum bit rate can support up to 390Mbps.

For 5.47-5.725GHz:

For 802.11a mode, it operates at frequency range of 5500.00MHz to 5700.000MHz with 11 channels. It transmits via Orthogonal Frequency Division Multiplexing (OFDM) modulation. Maximum bit rate can be up to 54Mbps.

For 802.11n (with 20MHz bandwidth) mode, it operates at frequency range of 5500MHz to 5700MHz with 11 channels. It transmits via Orthogonal Frequency Division Multiplexing (OFDM) modulation. Maximum bit rate can support up to 65Mbps.

For 802.11n (with 40MHz bandwidth) mode, it operates at frequency range of 5510.00MHz to 5670.000MHz with 5 channels. It transmits via Orthogonal Frequency Division Multiplexing (OFDM) modulation. Maximum bit rate can support up to 135Mbps.

For 802.11ac (with 20MHz bandwidth) mode, it operates at frequency range of 5500MHz to 5700MHz with 11 channels. It transmits via Orthogonal Frequency Division Multiplexing (OFDM) modulation. Maximum bit rate can support up to 86.7Mbps.

For 802.11ac (with 40MHz bandwidth) mode, it operates at frequency range of 5510.00MHz to 5670.000MHz with 5 channels. It transmits via Orthogonal Frequency Division Multiplexing (OFDM) modulation. Maximum bit rate can support up to 180Mbps.

For 802.11ac (with 80MHz bandwidth) mode, it operates at frequency range of 5530.00MHz to 5610.000MHz with 2 channels. It transmits via Orthogonal Frequency Division Multiplexing (OFDM) modulation. Maximum bit rate can support up to 390Mbps.

For 5.725-5.850GHz:

For 802.11a mode, it operates at frequency range of 5745.00MHz to 5825.000MHz with 5 channels. It transmits via Orthogonal Frequency Division Multiplexing (OFDM) modulation. Maximum bit rate can be up to 54Mbps.

For 802.11n (with 20MHz bandwidth) mode, it operates at frequency range of 5745MHz to 5825MHz with 5 channels. It transmits via Orthogonal Frequency Division Multiplexing (OFDM) modulation. Maximum bit rate can support up to 65Mbps.

For 802.11n (with 40MHz bandwidth) mode, it operates at frequency range of 5755.00MHz to 5795.000MHz with 2 channels. It transmits via Orthogonal Frequency Division Multiplexing (OFDM) modulation. Maximum bit rate can support up to 135Mbps.

For 802.11ac (with 20MHz bandwidth) mode, it operates at frequency range of 5745MHz to 5825MHz with 5 channels. It transmits via Orthogonal Frequency Division Multiplexing (OFDM) modulation. Maximum bit rate can support up to 86.7Mbps.

For 802.11ac (with 40MHz bandwidth) mode, it operates at frequency range of 5755.00MHz to 5795.000MHz with 2 channels. It transmits via Orthogonal Frequency Division Multiplexing (OFDM) modulation. Maximum bit rate can support up to 180Mbps.

For 802.11ac (with 80MHz bandwidth) mode, it operates at frequency 5775MHz. It transmits via Orthogonal Frequency Division Multiplexing (OFDM) modulation. Maximum bit rate can support up to 390Mbps.

TEST REPORT

DFS description for 5250MHz to 5350MHz and 5470MHz to 5725MHz:

The operating mode of this device is Client mode without radar detection function.(IP based system)
The Highest output power of this EUT is 16.36dBm.

This product equipped with double antenna in SISO mode and the antenna gain are stated as below:

Ant.1:

5150-5250 MHz: Antenna Gain = -2.7 dBi

5250-5350 MHz: Antenna Gain = -2.4 dBi

5470-5725 MHz: Antenna Gain = -0.1 dBi

5725-5850 MHz: Antenna Gain = -0.1 dBi

Ant.2:

5150-5250 MHz: Antenna Gain = 2.7 dBi

5250-5350 MHz: Antenna Gain = 4.1 dBi

5470-5725 MHz: Antenna Gain = 4.1 dBi

5725-5850 MHz: Antenna Gain = 4.3 dBi

The EUT is power by a 120VAC adaptor.

The antenna(s) used in the EUT is integral, and the test sample is a prototype.

This report covers 5.0GHz band WiFi portion only.

The Model: 100005693 is the same as the Model: WT9L11P44GD51 in electronics/electrical designs including software & firmware, PCB layout and construction design/physical design/enclosure as declared by client. The only differences between these models are brand name and model number to be sold for marketing purpose as declared by client.

TEST REPORT

2.2 Test Methodology

Both AC power line-conducted and radiated emission measurements were performed according to the procedures in ANSI C63.10 (2013). Preliminary radiated scans and all radiated measurements were performed in radiated emission test sites. All Radiated tests were performed at an antenna to EUT distance of 3 meters, unless stated otherwise in the "**Justification Section**" of this Application. Antenna port conducted measurements were performed according to ANSI C63.10 (2013) and KDB Publication No. 789033 D02 v02r01 .All other measurements were made in accordance with the procedures in 47 CFR Part 2.

2.3 Test Facility

The radiated emission test site and antenna port conducted measurement facility used to collect the radiated data and conductive data are at 16/F, Block A, Building 6, Baoneng Science and Technology Park, Qingxiang Road No.1, Longhua New District, Shenzhen, China. This test facility and site measurement data have been fully placed on file with the FCC.

2.4 Related Submittal(s) Grants

This is a single application for certification of a transceiver (WiFi portion)

TEST REPORT

3.0 SYSTEM TEST CONFIGURATION

3.1 Justification

For radiated emissions testing, the equipment under test (EUT) was setup to transmit / receive continuously to simplify the measurement methodology. Care was taken to ensure proper power supply voltages during testing. During testing, all cables (if any) were manipulated to produce worst case emissions.

The EUT was powered by a battery.

For the measurements, the EUT was attached to a plastic stand if necessary and placed on the wooden turntable. If the base unit attached to peripherals, they were connected and operational (as typical as possible).

The signal was maximized through rotation and placement in the three orthogonal axes. The antenna height and polarization were varied during the search for maximum signal level. The antenna height was varied from 1 to 4 meters. Radiated emissions were taken at three meters unless the signal level was too low for measurement at that distance. If necessary, a pre-amplifier was used and/or the test was conducted at a closer distance.

For any intentional radiator powered by AC power line, measurements of the radiated signal level of the fundamental frequency component of the emission was performed with the supply voltage varied between 85% and 115% of the nominal rated supply voltage.

Radiated emission measurement for transmitter were performed from the lowest radio frequency signal generated in the device which is greater than 9 kHz to the tenth harmonic of the highest fundamental frequency or to 40 GHz, whichever is lower.

Emission that are directly caused by digital circuits in the transmit path and transmitter portion were measured, and the limit are according to FCC Part 15 Section 15.209. Digital circuitries used to control additional functions other than the operation of the transmitter are subject to FCC Part 15 Section 15.109.

TEST REPORT

3.1 Justification – Cont'd

Detector function for radiated emissions was in peak mode. Average readings, when required, were taken by measuring the duty cycle of the equipment under test and subtracting the corresponding amount in dB from the measured peak readings. A detailed description for the calculation of the average factor can be found in section 4.8.3.

Determination of pulse desensitization was made according to *Hewlett Packard Application Note 150-2, Spectrum Analysis... Pulsed RF*. The effective period (Teff) was referred to Exhibit 4.8.3. With the resolution bandwidth 1MHz and spectrum analyzer IF bandwidth 3dB, the pulse desensitization factor was 0dB.

For AC line conducted emission test, the EUT along with its peripherals were placed on a 1.0m(W)x1.5m(L) and 0.8m in height wooden table and the EUT was adjusted to maintain a 0.4 meter space from a vertical reference plane. The EUT was connected to power mains through a line impedance stabilization network (LISN), which provided 50ohm coupling impedance for measuring instrument. The LISN housing, measuring instrument case, reference ground plane, and vertical ground plane were bounded together. The excess power cable between the EUT and the LISN was bundled.

All connecting cables of EUT and peripherals were manipulated to find the maximum emission.

Different data rates have been tested. Worst case is reported only.

All relevant operation modes have been tested, and the worst case data is included in this report.

All data rates were tested under normal mode of WiFi. Only the worst-case data is shown in the report for DSSS and OFDM

3.2 EUT Exercising Software

The EUT exercise program (if any) used during radiated and conducted testing was designed to exercise the various system components in a manner similar to a typical use.

TEST REPORT

3.3 Details of EUT and Description of Accessories

Details of EUT:

AC adaptor (provided with the unit) was used to power the device. Their description are listed below.

- (1) An AC adaptor (100V to 240V, Model: DBS018A-1201500U) (Provided by Applicant)
- (2) An AC adaptor (100V to 240V, Model: DCT18W120150US-A0) (Provided by Applicant)

Description of Accessories:

- (1) Keyboard (Provided by Applicant)

3.4 Measurement Uncertainty

When determining of the test conclusion, the Measurement Uncertainty of test at a level of confidence of 95% has been considered. The values of the Measurement uncertainty:

No.	Item	Measurement Uncertainty
1	Conducted emission 9KHz-150KHz	±3.8 dB
2	Conducted emission 150KHz-30MHz	±3.4 dB
3	Radiated emission 9KHz-30MHz	±4.9 dB
4	Radiated emission 30MHz-1GHz	±4.7 dB
5	Radiated emission 1GHz-18GHz	±5.1 dB
6	Radiated emission 18GHz-26GHz	±5.2 dB
7	Radiated emission 26GHz-40GHz	±5.2 dB

Uncertainty and Compliance - Unless the standard specifically states that measured values are to be extended by the measurement uncertainty in determining compliance, all compliance determinations are based on the actual measured value.

TEST REPORT

4.0 TEST RESULTS

4.1 Maximum Conducted (average) Output Power at Antenna Terminals

RF Conduct Measurement Test Setup

The figure below shows the test setup, which is utilized to make these measurements.

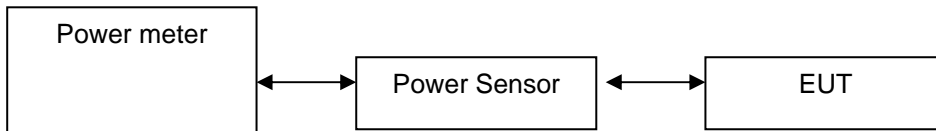

The antenna port of the EUT was connected to the input of a spectrum analyzer.

- The antenna power of the EUT was connected to the input of a power meter. Power was read directly and cable loss correction was added to the reading to the obtain power at the EUT antenna terminals. The measurement procedure E.3.A (789033 D02 V02r01) was used.
- The EUT should be configured to transmit continuously (at a minimum duty cycle of 98%) at full power over the measurement duration. The measurement procedure AVG1 was used.

IEEE 802.11ac (20MHz) (MCS0)

Antenna Gain (Ant. 1) = -2.7 dBi (5150-5250 MHz), -2.4 dBi (5250-5350 MHz), -0.1 dBi (5470-5725 MHz), -0.1 dBi (5725-5850 MHz)

Antenna Gain (Ant. 2) = 2.7 dBi (5150-5250 MHz), 4.1 dBi (5250-5350 MHz), 4.1 dBi (5470-5725 MHz), 4.3 dBi (5725-5850 MHz)

Frequency (MHz)	Conducted output power in dBm		Conducted output power in mWatt	
	Ant. 1	Ant. 2	Ant. 1	Ant. 2
5180	11.89	15.86	15.45	38.55
5220	12.39	16.22	17.34	41.88
5240	12.51	16.15	17.82	41.21
5260	12.96	16.03	19.77	40.09
5300	12.79	16.07	19.01	40.46
5320	12.68	15.84	18.54	38.37
5500	12.93	13.13	19.63	20.56
5580	13.26	13.55	21.18	22.65
5700	13.68	14.87	23.33	30.69
5745	13.91	14.02	24.60	25.23
5785	13.33	13.87	21.53	24.38
5825	12.77	13.51	18.92	22.44

TEST REPORT

4.1 Maximum Conducted Output Power at Antenna Terminals – Cont’d

IEEE 802.11ac (40MHz) (MCS0)

Antenna Gain (Ant. 1) = -2.7 dBi (5150-5250 MHz), -2.4 dBi (5250-5350 MHz), -0.1 dBi (5470-5725 MHz), -0.1 dBi (5725-5850 MHz)

Antenna Gain (Ant. 2) = 2.7 dBi (5150-5250 MHz), 4.1 dBi (5250-5350 MHz), 4.1 dBi (5470-5725 MHz), 4.3 dBi (5725-5850 MHz)

Frequency (MHz)	Conducted output power in dBm		Conducted output power in mWatt	
	Ant. 1	Ant. 2	Ant. 1	Ant. 2
5190	12.29	16.02	16.94	39.99
5230	12.39	16.24	17.34	42.07
5270	12.80	15.96	19.05	39.45
5310	12.71	15.92	18.66	39.08
5510	12.82	13.58	19.14	22.80
5550	12.70	13.24	18.62	21.09
5670	13.48	14.09	22.28	25.64
5755	13.68	13.69	23.33	23.39
5795	13.16	13.45	20.70	22.13

IEEE 802.11ac (80MHz) (MCS0)

Antenna Gain (Ant. 1) = -2.7 dBi (5150-5250 MHz), -2.4 dBi (5250-5350 MHz), -0.1 dBi (5470-5725 MHz), -0.1 dBi (5725-5850 MHz)

Antenna Gain (Ant. 2) = 2.7 dBi (5150-5250 MHz), 4.1 dBi (5250-5350 MHz), 4.1 dBi (5470-5725 MHz), 4.3 dBi (5725-5850 MHz)

Frequency (MHz)	Conducted output power in dBm		Conducted output power in mWatt	
	Ant. 1	Ant. 2	Ant. 1	Ant. 2
5210	12.16	15.73	16.44	37.41
5290	12.76	15.90	18.88	38.90
5530	12.38	13.32	17.30	21.48
5775	13.72	13.69	23.55	23.39

TEST REPORT

4.1 Maximum Conducted Output Power at Antenna Terminals – Cont’d

IEEE 802.11a (20MHz) (OFDM, 6 Mbps)

Antenna Gain (Ant. 1) = -2.7 dBi (5150-5250 MHz), -2.4 dBi (5250-5350 MHz), -0.1 dBi (5470-5725 MHz), -0.1 dBi (5725-5850 MHz)

Antenna Gain (Ant. 2) = 2.7 dBi (5150-5250 MHz), 4.1 dBi (5250-5350 MHz), 4.1 dBi (5470-5725 MHz), 4.3 dBi (5725-5850 MHz)

Frequency (MHz)	Conducted output power in dBm		Conducted output power in mWatt	
	Ant. 1	Ant. 2	Ant. 1	Ant. 2
5180	12.17	15.98	16.48	39.63
5220	12.73	16.36	18.75	43.25
5240	12.81	16.24	19.10	42.07
5260	12.72	16.12	18.71	40.93
5300	13.12	16.13	20.51	41.02
5320	13.15	15.97	20.65	39.54
5500	13.17	13.33	20.75	21.53
5580	13.14	13.69	20.61	23.39
5700	13.89	14.80	24.49	30.20
5745	14.09	14.16	25.64	26.06
5785	13.66	13.93	23.23	24.72
5825	13.01	13.53	20.00	22.54

IEEE 802.11n (20MHz) (OFDM, MCS0)

Antenna Gain (Ant. 1) = -2.7 dBi (5150-5250 MHz), -2.4 dBi (5250-5350 MHz), -0.1 dBi (5470-5725 MHz), -0.1 dBi (5725-5850 MHz)

Antenna Gain (Ant. 2) = 2.7 dBi (5150-5250 MHz), 4.1 dBi (5250-5350 MHz), 4.1 dBi (5470-5725 MHz), 4.3 dBi (5725-5850 MHz)

Frequency (MHz)	Conducted output power in dBm		Conducted output power in mWatt	
	Ant. 1	Ant. 2	Ant. 1	Ant. 2
5180	11.95	15.97	15.67	39.54
5220	12.48	16.25	17.70	42.17
5240	12.56	16.20	18.03	41.69
5260	12.97	16.07	19.82	40.46
5300	12.86	16.13	19.32	41.02
5320	12.78	15.88	18.97	38.73
5500	12.97	13.33	19.82	21.53
5580	13.37	13.55	21.73	22.65
5700	13.66	14.74	23.23	29.79
5745	13.95	14.08	24.83	25.59
5785	13.46	13.83	22.18	24.15
5825	12.86	13.67	19.32	23.28

TEST REPORT

4.1 Maximum Conducted Output Power at Antenna Terminals – Cont’d

IEEE 802.11n (40MHz) (OFDM, MCS0)

Antenna Gain (Ant. 1) = -2.7 dBi (5150-5250 MHz), -2.4 dBi (5250-5350 MHz), -0.1 dBi (5470-5725 MHz), -0.1 dBi (5725-5850 MHz)

Antenna Gain (Ant. 2) = 2.7 dBi (5150-5250 MHz), 4.1 dBi (5250-5350 MHz), 4.1 dBi (5470-5725 MHz), 4.3 dBi (5725-5850 MHz)

Frequency (MHz)	Conducted output power in dBm		Conducted output power in mWatt	
	Ant. 1	Ant. 2	Ant. 1	Ant. 2
5190	12.37	16.05	17.26	40.27
5230	12.45	16.24	17.58	42.07
5270	12.92	16.17	19.59	41.40
5310	12.87	15.95	19.36	39.36
5510	12.89	13.67	19.45	23.28
5550	12.82	13.21	19.14	20.94
5670	13.59	14.00	22.86	25.12
5755	13.80	13.75	23.99	23.71
5795	13.25	13.45	21.13	22.13

TEST REPORT

4.1 Maximum Conducted Output Power at Antenna Terminals – Cont'd

For maximum e.i.r.p.

IEEE 802.11ac (20MHz) (MCS0)

Antenna Gain (Ant. 1) = -2.7 dBi (5150-5250 MHz), Antenna Gain (Ant. 2) = 2.7 dBi (5150-5250 MHz)

Frequency (MHz)	Conducted output power in dBm		EIRP in dBm		EIRP in mWatt	
	Ant. 1	Ant. 2	Ant. 1	Ant. 2	Ant. 1	Ant. 2
5180	11.89	15.86	9.19	18.56	8.30	71.78
5220	12.39	16.22	9.69	18.92	9.31	77.98
5240	12.51	16.15	9.81	18.85	9.57	76.74

IEEE 802.11ac (40MHz) (MCS0)

Antenna Gain (Ant. 1) = -2.7 dBi (5150-5250 MHz), Antenna Gain (Ant. 2) = 2.7 dBi (5150-5250 MHz)

Frequency (MHz)	Conducted output power in dBm		EIRP in dBm		EIRP in mWatt	
	Ant. 1	Ant. 2	Ant. 1	Ant. 2	Ant. 1	Ant. 2
5190	12.29	16.02	9.59	18.72	9.10	74.47
5230	12.39	16.24	9.69	18.94	9.31	78.34

IEEE 802.11ac (80MHz) (MCS0)

Antenna Gain (Ant. 1) = -2.7 dBi (5150-5250 MHz), Antenna Gain (Ant. 2) = 2.7 dBi (5150-5250 MHz)

Frequency (MHz)	Conducted output power in dBm		EIRP in dBm		EIRP in mWatt	
	Ant. 1	Ant. 2	Ant. 1	Ant. 2	Ant. 1	Ant. 2
5210	12.16	15.73	9.46	18.43	8.83	69.66

IEEE 802.11a (20MHz) (OFDM, 6 Mbps)

Antenna Gain (Ant. 1) = -2.7 dBi (5150-5250 MHz), Antenna Gain (Ant. 2) = 2.7 dBi (5150-5250 MHz)

Frequency (MHz)	Conducted output power in dBm		EIRP in dBm		EIRP in mWatt	
	Ant. 1	Ant. 2	Ant. 1	Ant. 2	Ant. 1	Ant. 2
5180	12.17	15.98	9.47	18.68	8.85	73.79
5220	12.73	16.36	10.03	19.06	10.07	80.54
5240	12.81	16.24	10.11	18.94	10.26	78.34

IEEE 802.11n (20MHz) (OFDM, MCS0)

Antenna Gain (Ant. 1) = -2.7 dBi (5150-5250 MHz), Antenna Gain (Ant. 2) = 2.7 dBi (5150-5250 MHz)

Frequency (MHz)	Conducted output power in dBm		EIRP in dBm		EIRP in mWatt	
	Ant. 1	Ant. 2	Ant. 1	Ant. 2	Ant. 1	Ant. 2
5180	11.95	15.97	9.25	18.67	8.41	73.62
5220	12.48	16.25	9.78	18.95	9.51	78.52
5240	12.56	16.20	9.86	18.90	9.68	77.62

TEST REPORT

4.1 Maximum Conducted Output Power at Antenna Terminals – Cont’d

IEEE 802.11n (40MHz) (OFDM, MCS0)

Antenna Gain (Ant. 1) = -2.7 dBi (5150-5250 MHz), Antenna Gain (Ant. 2) = 2.7 dBi (5150-5250 MHz)

Frequency (MHz)	Conducted output power in dBm		EIRP in dBm		EIRP in mWatt	
	Ant. 1	Ant. 2	Ant. 1	Ant. 2	Ant. 1	Ant. 2
5190	12.37	16.05	9.67	18.75	9.27	74.99
5230	12.45	16.24	9.75	18.94	9.44	78.34

Cable loss : 0.5 dB External Attenuation : 0 dB

Cable loss, external attenuation: included in OFFSET function
 added to SA raw reading

Ant. 1:

IEEE 802.11ac (20MHz) (OFDM, MCS0)

max. conducted output level = 13.91 dBm

IEEE 802.11ac (40MHz) (OFDM, MCS0)

max. conducted output level = 13.68 dBm

IEEE 802.11ac (80MHz) (OFDM, MCS0)

max. conducted output level = 13.72 dBm

IEEE 802.11a (20MHz) (OFDM, 6 Mbps)

max. conducted output level = 14.09 dBm

IEEE 802.11n (20MHz) (OFDM, MCS0)

max. conducted output level = 13.95 dBm

IEEE 802.11n (40MHz) (OFDM, MCS0)

max. conducted output level = 13.80 dBm

Ant. 2:

IEEE 802.11ac (20MHz) (OFDM, MCS0)

max. conducted output level = 16.22 dBm

IEEE 802.11ac (40MHz) (OFDM, MCS0)

max. conducted output level = 16.24 dBm

IEEE 802.11ac (80MHz) (OFDM, MCS0)

max. conducted output level = 15.90 dBm

IEEE 802.11a (20MHz) (OFDM, 6 Mbps)

max. conducted output level = 16.36 dBm

IEEE 802.11n (20MHz) (OFDM, MCS0)

max. conducted output level = 16.25 dBm

TEST REPORT

4.1 Maximum Conducted Output Power at Antenna Terminals – Cont'd

IEEE 802.11n (40MHz) (OFDM, MCS0)

max. conducted output level = 16.24 dBm

Remark:

1. Maximum e.i.r.p = Maximum conducted output power + Duty Cycle Factor + Antenna Gain
2. Maximum conducted output power = Conducted output power + Duty Cycle Factor
3. Duty cycle= On Time/ Period;
Duty Cycle factor = $10 * \log(1/ \text{Duty cycle})$;
Average factor = $20 \log_{10} \text{Duty Cycle}$.

Limits:

5150-5250MHz:

250mW (24dBm) for antennas with gains of 6dBi or less.(Client device)

5250-5350MHz:

250mW (24dBm)

5470-5725MHz:

250mW (24dBm)

5725-5850MHz:

1W (30dBm) for antennas with gains of 6dBi or less.

The plots of conducted output power are saved as below.

TEST REPORT

4.2 Minimum 6dB RF Bandwidth

The antenna port of the EUT was connected to the input of a spectrum analyzer. The EBW measurement procedure was used. A PEAK output reading was taken, a DISPLAY line was drawn 6dB lower than PEAK level. The 6dB bandwidth was determined from where the channel output spectrum intersected the display line.

IEEE 802.11ac (20MHz) (MCS0)

Frequency (MHz)	6dB Bandwidth (MHz)		99% Bandwidth (MHz)	
	Ant. 1	Ant. 2	Ant. 1	Ant. 2
5745	15.17	15.35	17.592	17.587
5785	15.10	15.35	17.588	17.584
5825	15.34	15.48	17.613	17.607

IEEE 802.11ac (40MHz) (MCS0)

Frequency (MHz)	6dB Bandwidth (MHz)		99% Bandwidth (MHz)	
	Ant. 1	Ant. 2	Ant. 1	Ant. 2
5755	35.21	35.20	35.918	35.942
5795	35.21	35.22	35.917	35.916

IEEE 802.11ac (80MHz) (MCS0)

Frequency (MHz)	6dB Bandwidth (MHz)		99% Bandwidth (MHz)	
	Ant. 1	Ant. 2	Ant. 1	Ant. 2
5775	75.22	75.40	75.245	75.401

IEEE 802.11a (20MHz) (OFDM, 6Mbps)

Frequency (MHz)	6dB Bandwidth (MHz)		99% Bandwidth (MHz)	
	Ant. 1	Ant. 2	Ant. 1	Ant. 2
5745	15.17	15.15	16.413	16.389
5785	15.16	15.17	16.414	16.427
5825	15.17	15.48	16.409	16.396

IEEE 802.11n (40MHz) (OFDM, MCS0)

Frequency (MHz)	6dB Bandwidth (MHz)		99% Bandwidth (MHz)	
	Ant. 1	Ant. 2	Ant. 1	Ant. 2
5755	35.16	35.19	35.932	35.922
5795	35.20	35.19	35.951	35.894

TEST REPORT

IEEE 802.11n (20MHz) (OFDM, MCS0)

Frequency (MHz)	6dB Bandwidth (MHz)		99% Bandwidth (MHz)	
	Ant. 1	Ant. 2	Ant. 1	Ant. 2
5745	15.15	15.14	17.601	17.584
5785	15.18	15.17	17.618	17.587
5825	15.14	15.17	17.619	17.597

Limits:

6 dB bandwidth shall be at least 500kHz

The plots of 6dB RF bandwidth and occupied bandwidth are saved with filename : ANTA UNII-1.pdf, ANTB UNII-1.pdf, ANTA UNII-3.pdf, ANTB UNII-3.pdf

TEST REPORT

4.3 26 dB Bandwidth & Occupied Bandwidth

The antenna port of the EUT was connected to the input of a spectrum analyzer. The EBW measurement procedure was used. A PEAK output reading was taken, a DISPLAY line was drawn 26dB lower than PEAK level. The 26dB bandwidth was determined from where the channel output spectrum intersected the display line.

IEEE 802.11ac (20MHz) (MCS0)

Frequency (MHz)	26dB Bandwidth (MHz)		99% Bandwidth (MHz)	
	Ant. 1	Ant. 2	Ant. 1	Ant. 2
5180	23.05	22.76	17.772	17.731
5220	23.72	22.56	17.722	17.749
5240	22.65	25.16	17.737	17.782
5260	22.92	23.73	17.736	17.796
5300	23.86	24.83	17.781	17.828
5320	24.29	24.63	17.774	17.888
5500	24.45	25.10	17.805	17.877
5580	23.63	23.45	17.742	17.758
5700	23.72	22.25	17.764	17.711

IEEE 802.11ac (40MHz) (MCS0)

Frequency (MHz)	26dB Bandwidth (MHz)		99% Bandwidth (MHz)	
	Ant. 1	Ant. 2	Ant. 1	Ant. 2
5190	42.45	41.95	36.150	36.090
5230	42.16	42.54	36.097	36.069
5270	42.22	42.24	36.124	36.146
5310	42.54	45.12	36.134	36.242
5510	43.10	43.70	36.164	36.174
5550	42.38	42.64	36.145	36.119
5670	42.01	43.07	36.045	36.086

IEEE 802.11ac (80MHz) (MCS0)

Frequency (MHz)	26dB Bandwidth (MHz)		99% Bandwidth (MHz)	
	Ant. 1	Ant. 2	Ant. 1	Ant. 2
5210	81.86	126.3	75.196	75.782
5290	81.77	117.8	75.290	75.632
5530	81.52	81.91	75.330	75.298

TEST REPORT

IEEE 802.11a (20MHz) (OFDM, 6Mbps)

Frequency (MHz)	26dB Bandwidth (MHz)		99% Bandwidth (MHz)	
	Ant. 1	Ant. 2	Ant. 1	Ant. 2
5180	22.23	23.20	16.565	16.563
5220	22.41	22.17	16.648	16.579
5240	23.00	24.48	16.623	16.646
5260	22.77	23.34	16.683	16.628
5300	23.81	24.89	16.711	16.685
5320	23.49	24.45	16.710	16.703
5500	23.48	23.79	16.664	16.687
5580	24.08	23.84	16.618	16.617
5700	23.54	21.12	16.623	16.535

IEEE 802.11n (20MHz) (OFDM, MCS0)

Frequency (MHz)	26dB Bandwidth (MHz)		99% Bandwidth (MHz)	
	Ant. 1	Ant. 2	Ant. 1	Ant. 2
5180	23.18	22.35	17.750	17.726
5220	23.09	24.16	17.727	17.751
5240	22.53	23.54	17.739	17.775
5260	23.35	24.21	17.739	17.805
5300	24.02	24.59	17.777	17.801
5320	23.59	25.73	17.754	17.839
5500	23.72	24.30	17.748	17.822
5580	23.20	23.66	17.721	17.734
5700	22.94	22.50	17.694	17.728

IEEE 802.11N (40MHz) (OFDM, MCS0)

Frequency (MHz)	26dB Bandwidth (MHz)		99% Bandwidth (MHz)	
	Ant. 1	Ant. 2	Ant. 1	Ant. 2
5190	41.76	41.70	36.121	36.117
5230	42.26	41.72	36.085	36.095
5270	41.24	44.43	36.081	36.134
5310	43.51	44.16	36.127	36.156
5510	42.44	44.53	36.144	36.146
5550	43.39	43.68	36.120	36.106
5670	42.53	42.68	36.101	36.090

TEST REPORT

4.4 Maximum Power Spectral Density

The output from the transmitter was connected to an attenuator and then to the input of the RF Spectrum Analyzer.

Spectrum 23nalyser according to the following Settings:

1. For U-NII-1, U-NII-2A, U-NII-2C band:

Using method SA-2

- a) Set span to encompass the entire emission bandwidth (EBW) of the signal.
- b) Set RBW = 1 MHz, Set VBW \geq 3 RBW, Detector = RMS
- c) Sweep time = auto, trigger set to "free run".
- d) Trace average at least 100 traces in power averaging mode.
- e) Record the max value and add 10 log (1/duty cycle)

2. For U-NII-3 band:

- a) Set span to encompass the entire emission bandwidth (EBW) of the signal.
- b) Set RBW = 500 kHz, Set VBW \geq 3 RBW, Detector = RMS
- c) Use the peak marker function to determine the maximum power level in any 500 kHz band segment within the fundamental EBW.
- d) Sweep time = auto, trigger set to "free run".
- e) Trace average at least 100 traces in power averaging mode.
- f) Record the max value and add 10 log (1/duty cycle)

Note: The cable loss and attenuator loss were offset into measure device as an amplitude offset.

IEEE 802.11a (20MHz) (OFDM, 6 Mbps)

Frequency (MHz)	Conducted PSD in 1MHz (dBm)	
	Ant. 1	Ant. 2
5180	2.14	5.25
5220	1.86	5.21
5240	1.77	5.32
5260	1.95	5.31
5300	1.97	4.75
5320	2.00	4.36
5500	2.77	2.94
5580	3.06	3.30
5700	3.93	4.38

Frequency (MHz)	Conducted PSD in 500kHz (dBm)	
	Ant. 1	Ant. 2
5745	0.34	0.47
5785	-0.63	-0.15
5825	-0.79	-0.47

TEST REPORT

IEEE 802.11ac (20MHz) (MCS0)

Frequency (MHz)	Conducted PSD in 1MHz (dBm)	
	Ant. 1	Ant. 2
5180	1.51	4.65
5220	1.60	4.80
5240	1.81	4.93
5260	1.73	5.16
5300	1.35	4.55
5320	1.60	4.17
5500	2.06	2.54
5580	2.34	2.29
5700	3.33	3.94

Frequency (MHz)	Conducted PSD in 500kHz (dBm)	
	Ant. 1	Ant. 2
5745	0.14	-0.52
5785	-0.53	0.03
5825	-1.28	-0.79

IEEE 802.11ac (40MHz) (MCS0)

Frequency (MHz)	Conducted PSD in 1MHz (dBm)	
	Ant. 1	Ant. 2
5190	-2.12	2.08
5230	-1.55	1.74
5270	-1.69	1.15
5310	-1.23	1.31
5510	-1.19	-1.07
5550	-0.74	-0.51
5670	0.03	0.50

Frequency (MHz)	Conducted PSD in 500kHz (dBm)	
	Ant. 1	Ant. 2
5755	-2.97	-4.07
5795	-3.73	-3.84

TEST REPORT

IEEE 802.11ac (80MHz) (MCS0)

Frequency (MHz)	Conducted PSD in 1MHz (dBm)	
	Ant. 1	Ant. 2
5210	-5.16	-4.56
5290	-4.43	-4.44
5530	-4.55	-7.00

Frequency (MHz)	Conducted PSD in 500kHz (dBm)	
	Ant. 1	Ant. 2
5775	-5.84	-6.34

IEEE 802.11n (20MHz) (OFDM, MCS0)

Frequency (MHz)	Conducted PSD in 1MHz (dBm)	
	Ant. 1	Ant. 2
5180	1.22	5.08
5220	2.02	4.68
5240	1.81	4.47
5260	1.44	5.04
5300	1.24	4.70
5320	1.40	4.34
5500	2.26	2.64
5580	2.61	3.07
5700	3.48	4.09

Frequency (MHz)	Conducted PSD in 500kHz (dBm)	
	Ant. 1	Ant. 2
5745	0.25	0.06
5785	-0.60	-0.30
5825	-0.80	-0.50

TEST REPORT

IEEE 802.11n (40MHz) (OFDM, MCS0)

Frequency (MHz)	Conducted PSD in 1MHz (dBm)	
	Ant. 1	Ant. 2
5190	-2.22	1.21
5230	-1.50	1.89
5270	-1.63	1.40
5310	-0.84	0.90
5510	-0.92	-0.97
5550	-0.99	-0.54
5670	0.05	-0.23

Frequency (MHz)	Conducted PSD in 500kHz (dBm)	
	Ant. 1	Ant. 2
5755	-3.43	-3.56
5795	-3.51	-3.32

TEST REPORT

For maximum e.i.r.p.

IEEE 802.11a (20MHz) (OFDM, 6 Mbps)

Frequency (MHz)	EIRP PSD in 1MHz (dBm)	
	Ant. 1	Ant. 2
5180	-0.56	7.95
5220	-0.84	7.91
5240	-0.93	8.02

IEEE 802.11ac (20MHz) (MCS0)

Frequency (MHz)	EIRP PSD in 1MHz (dBm)	
	Ant. 1	Ant. 2
5180	-1.19	7.35
5220	-1.10	7.50
5240	-0.89	7.63

IEEE 802.11ac (40MHz) (MCS0)

Frequency (MHz)	EIRP PSD in 1MHz (dBm)	
	Ant. 1	Ant. 2
5190	-4.82	4.78
5230	-4.25	4.44

IEEE 802.11ac (80MHz) (MCS0)

Frequency (MHz)	EIRP PSD in 1MHz (dBm)	
	Ant. 1	Ant. 2
5210	-7.86	-1.86

IEEE 802.11n (20MHz) (OFDM, MCS0)

Frequency (MHz)	EIRP PSD in 1MHz (dBm)	
	Ant. 1	Ant. 2
5180	-1.48	7.78
5220	-0.69	7.38
5240	-0.90	7.17

TEST REPORT

IEEE 802.11n (40MHz) (OFDM, MCS0)

Frequency (MHz)	EIRP	
	PSD in 1MHz (dBm)	
	Ant. 1	Ant. 2
5190	-4.92	3.91
5230	-4.20	4.59

Remark:

1. Cable Loss: 0.5 dB
2. **Error! Reference source not found.**e.i.r.p. spectral density = Power spectral density + Duty Cycle Factor + Antenna Gain
3. Power spectral density = Conducted power spectral density + Duty Cycle Factor
4. Duty cycle= On Time/ Period;
Duty Cycle factor = $10 * \log(1/ \text{Duty cycle})$;
Average factor = $20 \log_{10} \text{Duty Cycle}$.

Limit:

For U-NII-1:

FCC: 11dBm/MHz for mobile/portable device.

For U-NII-2:

FCC: 11dBm/MHz

For U-NII-3:

FCC: 30dBm/500kHz

The test data are saved with filename: PSD DATA.pdf

TEST REPORT

4.5 Field Strength Calculation

The field strength is calculated by adding the reading on the Spectrum Analyzer to the factors associated with preamplifiers (if any), antennas, cables, pulse desensitization and average factors (when specified limit is in average and measurements are made with peak detectors). A sample calculation is included below.

$$FS = RA + AF + CF - AG + PD + AV$$

Where FS = Field Strength in dB μ V/m

RA = Receiver Amplitude (including preamplifier) in dB μ V

CF = Cable Attenuation Factor in dB

AF = Antenna Factor in dB

AG = Amplifier Gain in dB

PD = Pulse Desensitization in dB

AV = Average Factor in -dB

In the radiated emission table which follows, the reading shown on the data table may reflect the preamplifier gain. An example of the calculations, where the reading does not reflect the preamplifier gain, follows:

$$FS = RA + AF + CF - AG + PD + AV$$

Example

Assume a receiver reading of 62.0 dB μ V is obtained. The antenna factor of 7.4 dB and cable factor of 1.6 dB is added. The amplifier gain of 29.0 dB is subtracted. The pulse desensitization factor of the spectrum analyzer is 0.0 dB, and the resultant average factor is -10.0 dB. The net field strength for comparison to the appropriate emission limit is 32.0 dB μ V/m. This value in dB μ V/m is converted to its corresponding level in μ V/m.

$$RA = 62.0 \text{ dB}\mu\text{V}$$

$$AF = 7.4 \text{ dB}$$

$$CF = 1.6 \text{ dB}$$

$$AG = 29.0 \text{ dB}$$

$$PD = 0.0 \text{ dB}$$

$$AV = -10 \text{ dB}$$

$$FS = 62.0 + 7.4 + 1.6 - 29.0 + 0.0 + (-10.0) = 32.0 \text{ dB}\mu\text{V/m}$$

$$\text{Level in } \mu\text{V/m} = \text{Common Antilogarithm } [(32.0 \text{ dB}\mu\text{V/m})/20] = 39.8 \mu\text{V/m}$$

TEST REPORT

4.6 Transmitter Radiated Emissions in Restricted Bands and Spurious Emissions

Data is included of the worst case configuration (the configuration which resulted in the highest emission levels). A sample calculation, configuration photographs and data tables of the emissions are included.

The data on the following pages list the significant emission frequencies, the limit and the margin of compliance.

4.6.1 Radiated Emission Configuration Photograph

Worst Case Restricted Band Radiated Emission
at

5470 MHz

The worst case radiated emission configuration photographs are saved with filename: config photos.pdf

4.6.2 Radiated Emission Data

The data in tables list the significant emission frequencies, the limit and the margin of compliance.

Judgement -

Passed by 0.94 dB margin

TEST REPORT

RADIATED EMISSION DATA

Ant. 1_ IEEE 802.11A (20MHz) (OFDM,6MBs)

Radiated Emission Test Data (Above 1GHz):

IEEE 802.11a_Channel 36

No.	Frequency (MHz)	Reading (dBuV/m)	Correction factor (dB)	Result (dBuV/m)	Limit (dBuV/m)	Margin (dB)	Detector	Antenna Polaxis
1	10360.00	38.47	11.11	49.58	74.00	24.42	Peak	Horizontal
2	10360.00	26.90	11.11	38.01	54.00	15.99	Average	Horizontal
3	15540.00	45.99	10.76	56.75	74.00	17.25	Peak	Horizontal
4	15540.00	29.29	10.76	40.05	54.00	13.95	Average	Horizontal
5	10360.00	35.91	9.39	45.30	74.00	28.70	Peak	Vertical
6	10360.00	24.09	9.39	33.48	54.00	20.52	Average	Vertical
7	15540.00	47.99	11.59	59.58	74.00	14.42	Peak	Vertical
8	15540.00	30.33	11.59	41.92	54.00	12.08	Average	Vertical

IEEE 802.11a_Channel 44

No.	Frequency (MHz)	Reading (dBuV/m)	Correction factor (dB)	Result (dBuV/m)	Limit (dBuV/m)	Margin (dB)	Detector	Antenna Polaxis
1	10440.00	37.58	11.31	48.89	74.00	25.11	Peak	Horizontal
2	10440.00	26.02	11.31	37.33	54.00	16.67	Average	Horizontal
3	15660.00	44.63	11.00	55.63	74.00	18.37	Peak	Horizontal
4	15660.00	29.15	11.00	40.15	54.00	13.85	Average	Horizontal
5	10440.00	36.23	9.43	45.66	74.00	28.34	Peak	Vertical
6	10440.00	24.86	9.43	34.29	54.00	19.71	Average	Vertical
7	15660.00	48.29	11.93	60.22	74.00	13.78	Peak	Vertical
8	15660.00	31.78	11.93	43.71	54.00	10.29	Average	Vertical

IEEE 802.11a_Channel 48

No.	Frequency (MHz)	Reading (dBuV/m)	Correction factor (dB)	Result (dBuV/m)	Limit (dBuV/m)	Margin (dB)	Detector	Antenna Polaxis
1	10480.00	37.28	11.41	48.69	74.00	25.31	Peak	Horizontal
2	10480.00	25.69	11.41	37.10	54.00	16.90	Average	Horizontal
3	15720.00	46.67	11.08	57.75	74.00	16.25	Peak	Horizontal
4	15720.00	28.71	11.08	39.79	54.00	14.21	Average	Horizontal
5	10480.00	35.56	9.45	45.01	74.00	28.99	Peak	Vertical
6	10480.00	23.99	9.45	33.44	54.00	20.56	Average	Vertical
7	15720.00	47.05	12.05	59.10	74.00	14.90	Peak	Vertical
8	15720.00	28.83	12.05	40.88	54.00	13.12	Average	Vertical

TEST REPORT

IEEE 802.11a_Channel 52

No.	Frequency (MHz)	Reading (dBuV/m)	Correction factor (dB)	Result (dBuV/m)	Limit (dBuV/m)	Margin (dB)	Detector	Antenna Polaxis
1	10520.00	37.43	11.42	48.85	74.00	25.15	Peak	Horizontal
2	10520.00	25.97	11.42	37.39	54.00	16.61	Average	Horizontal
3	15780.00	46.09	11.16	57.25	74.00	16.75	Peak	Horizontal
4	15780.00	26.41	11.16	37.57	54.00	16.43	Average	Horizontal
5	10520.00	36.90	9.43	46.33	74.00	27.67	Peak	Vertical
6	10520.00	24.28	9.43	33.71	54.00	20.29	Average	Vertical
7	15780.00	46.99	12.19	59.18	74.00	14.82	Peak	Vertical
8	15780.00	25.81	12.19	38.00	54.00	16.00	Average	Vertical

IEEE 802.11a_Channel 60

No.	Frequency (MHz)	Reading (dBuV/m)	Correction factor (dB)	Result (dBuV/m)	Limit (dBuV/m)	Margin (dB)	Detector	Antenna Polaxis
1	10600.00	36.85	11.33	48.18	74.00	25.82	Peak	Horizontal
2	10600.00	25.99	11.33	37.32	54.00	16.68	Average	Horizontal
3	15900.00	43.86	11.33	55.19	74.00	18.81	Peak	Horizontal
4	15900.00	27.22	11.33	38.55	54.00	15.45	Average	Horizontal
5	10600.00	35.99	9.37	45.36	74.00	28.64	Peak	Vertical
6	10600.00	24.59	9.37	33.96	54.00	20.04	Average	Vertical
7	15900.00	46.93	12.45	59.38	74.00	14.62	Peak	Vertical
8	15900.00	28.07	12.45	40.52	54.00	13.48	Average	Vertical

IEEE 802.11a_Channel 64

No.	Frequency (MHz)	Reading (dBuV/m)	Correction factor (dB)	Result (dBuV/m)	Limit (dBuV/m)	Margin (dB)	Detector	Antenna Polaxis
1	10640.00	37.61	11.29	48.90	74.00	25.10	Peak	Horizontal
2	10640.00	26.24	11.29	37.53	54.00	16.47	Average	Horizontal
3	15960.00	44.92	11.49	56.41	74.00	17.59	Peak	Horizontal
4	15960.00	26.24	11.49	37.73	54.00	16.27	Average	Horizontal
5	10640.00	36.11	9.34	45.45	74.00	28.55	Peak	Vertical
6	10640.00	24.79	9.34	34.13	54.00	19.87	Average	Vertical
7	15960.00	44.37	12.66	57.03	74.00	16.97	Peak	Vertical
8	15960.00	25.57	12.66	38.23	54.00	15.77	Average	Vertical

TEST REPORT

IEEE 802.11a_Channel 100

No.	Frequency (MHz)	Reading (dBuV/m)	Correction factor (dB)	Result (dBuV/m)	Limit (dBuV/m)	Margin (dB)	Detector	Antenna Polaxis
1	11000.00	39.01	10.30	49.31	74.00	24.69	Peak	Horizontal
2	11000.00	26.64	10.30	36.94	54.00	17.06	Average	Horizontal
3	16500.00	45.09	13.35	58.44	74.00	15.56	Peak	Horizontal
4	16500.00	28.05	13.35	41.40	54.00	12.60	Average	Horizontal
5	11000.00	37.69	8.50	46.19	74.00	27.81	Peak	Vertical
6	11000.00	26.71	8.50	35.21	54.00	18.79	Average	Vertical
7	16500.00	46.61	13.45	60.06	74.00	13.94	Peak	Vertical
8	16500.00	28.48	13.45	41.93	54.00	12.07	Average	Vertical

IEEE 802.11a_Channel 116

No.	Frequency (MHz)	Reading (dBuV/m)	Correction factor (dB)	Result (dBuV/m)	Limit (dBuV/m)	Margin (dB)	Detector	Antenna Polaxis
1	11160.00	38.10	9.97	48.07	74.00	25.93	Peak	Horizontal
2	11160.00	26.11	9.97	36.08	54.00	17.92	Average	Horizontal
3	16740.00	42.38	13.24	55.62	74.00	18.38	Peak	Horizontal
4	16740.00	24.47	13.24	37.71	54.00	16.29	Average	Horizontal
5	11160.00	38.07	8.27	46.34	74.00	27.66	Peak	Vertical
6	11160.00	26.02	8.27	34.29	54.00	19.71	Average	Vertical
7	16740.00	40.44	13.01	53.45	74.00	20.55	Peak	Vertical
8	16740.00	25.19	13.01	38.20	54.00	15.80	Average	Vertical

IEEE 802.11a_Channel 140

No.	Frequency (MHz)	Reading (dBuV/m)	Correction factor (dB)	Result (dBuV/m)	Limit (dBuV/m)	Margin (dB)	Detector	Antenna Polaxis
1	11400.00	37.94	9.86	47.80	74.00	26.20	Peak	Horizontal
2	11400.00	26.85	9.86	36.71	54.00	17.29	Average	Horizontal
3	17100.00	41.51	13.42	54.93	74.00	19.07	Peak	Horizontal
4	17100.00	24.39	13.42	37.81	54.00	16.19	Average	Horizontal
5	11400.00	38.52	8.30	46.82	74.00	27.18	Peak	Vertical
6	11400.00	27.23	8.30	35.53	54.00	18.47	Average	Vertical
7	17100.00	39.55	12.76	52.31	74.00	21.69	Peak	Vertical
8	17100.00	22.35	12.76	35.11	54.00	18.89	Average	Vertical

TEST REPORT

IEEE 802.11a_Channel 149

No.	Frequency (MHz)	Reading (dBuV/m)	Correction factor (dB)	Result (dBuV/m)	Limit (dBuV/m)	Margin (dB)	Detector	Antenna Polaxis
1	11490.00	38.27	9.78	48.05	74.00	25.95	Peak	Horizontal
2	11490.00	26.80	9.78	36.58	54.00	17.42	Average	Horizontal
3	17235.00	36.22	13.98	50.20	74.00	23.80	Peak	Horizontal
4	17235.00	24.47	13.98	38.45	54.00	15.55	Average	Horizontal
5	11490.00	38.58	8.27	46.85	74.00	27.15	Peak	Vertical
6	11490.00	27.04	8.27	35.31	54.00	18.69	Average	Vertical
7	17235.00	37.61	13.24	50.85	74.00	23.15	Peak	Vertical
8	17235.00	23.99	13.24	37.23	54.00	16.77	Average	Vertical

IEEE 802.11a_Channel 157

No.	Frequency (MHz)	Reading (dBuV/m)	Correction factor (dB)	Result (dBuV/m)	Limit (dBuV/m)	Margin (dB)	Detector	Antenna Polaxis
1	11570.00	38.04	9.86	47.90	74.00	26.10	Peak	Horizontal
2	11570.00	26.25	9.86	36.11	54.00	17.89	Average	Horizontal
3	17355.00	42.97	14.49	57.46	74.00	16.54	Peak	Horizontal
4	17355.00	25.85	14.49	40.34	54.00	13.66	Average	Horizontal
5	11570.00	38.43	8.47	46.90	74.00	27.10	Peak	Vertical
6	11570.00	26.50	8.47	34.97	54.00	19.03	Average	Vertical
7	17355.00	41.92	13.68	55.60	74.00	18.40	Peak	Vertical
8	17355.00	25.53	13.68	39.21	54.00	14.79	Average	Vertical

IEEE 802.11a_Channel 165

No.	Frequency (MHz)	Reading (dBuV/m)	Correction factor (dB)	Result (dBuV/m)	Limit (dBuV/m)	Margin (dB)	Detector	Antenna Polaxis
1	11650.00	37.85	9.95	47.80	74.00	26.20	Peak	Horizontal
2	11650.00	26.32	9.95	36.27	54.00	17.73	Average	Horizontal
3	17475.00	44.89	14.89	59.78	74.00	14.22	Peak	Horizontal
4	17475.00	25.75	14.89	40.64	54.00	13.36	Average	Horizontal
5	11650.00	37.96	8.69	46.65	74.00	27.35	Peak	Vertical
6	11650.00	26.53	8.69	35.22	54.00	18.78	Average	Vertical
7	17475.00	46.51	14.00	60.51	74.00	13.49	Peak	Vertical
8	17475.00	29.47	14.00	43.47	54.00	10.53	Average	Vertical

TEST REPORT

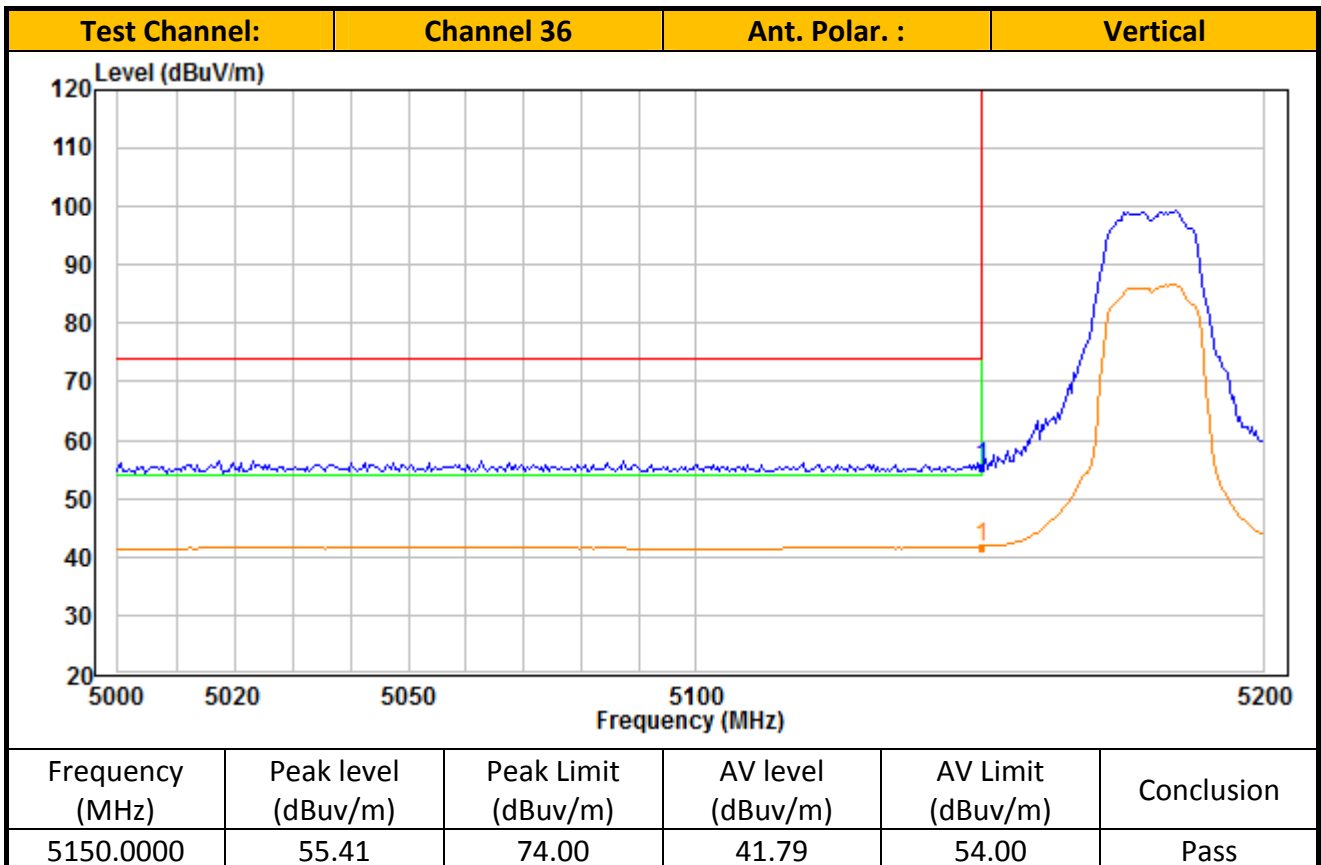
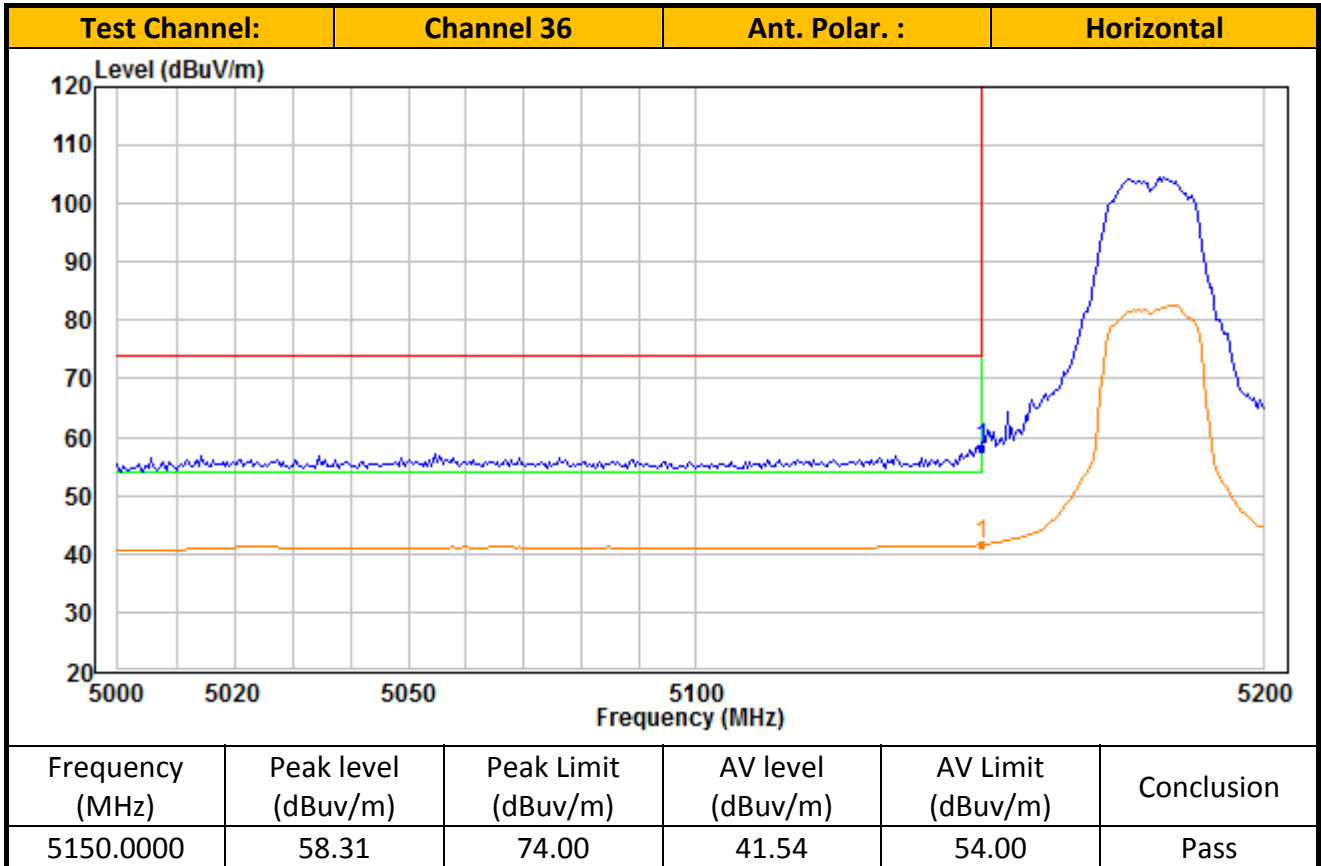

TEST REPORT

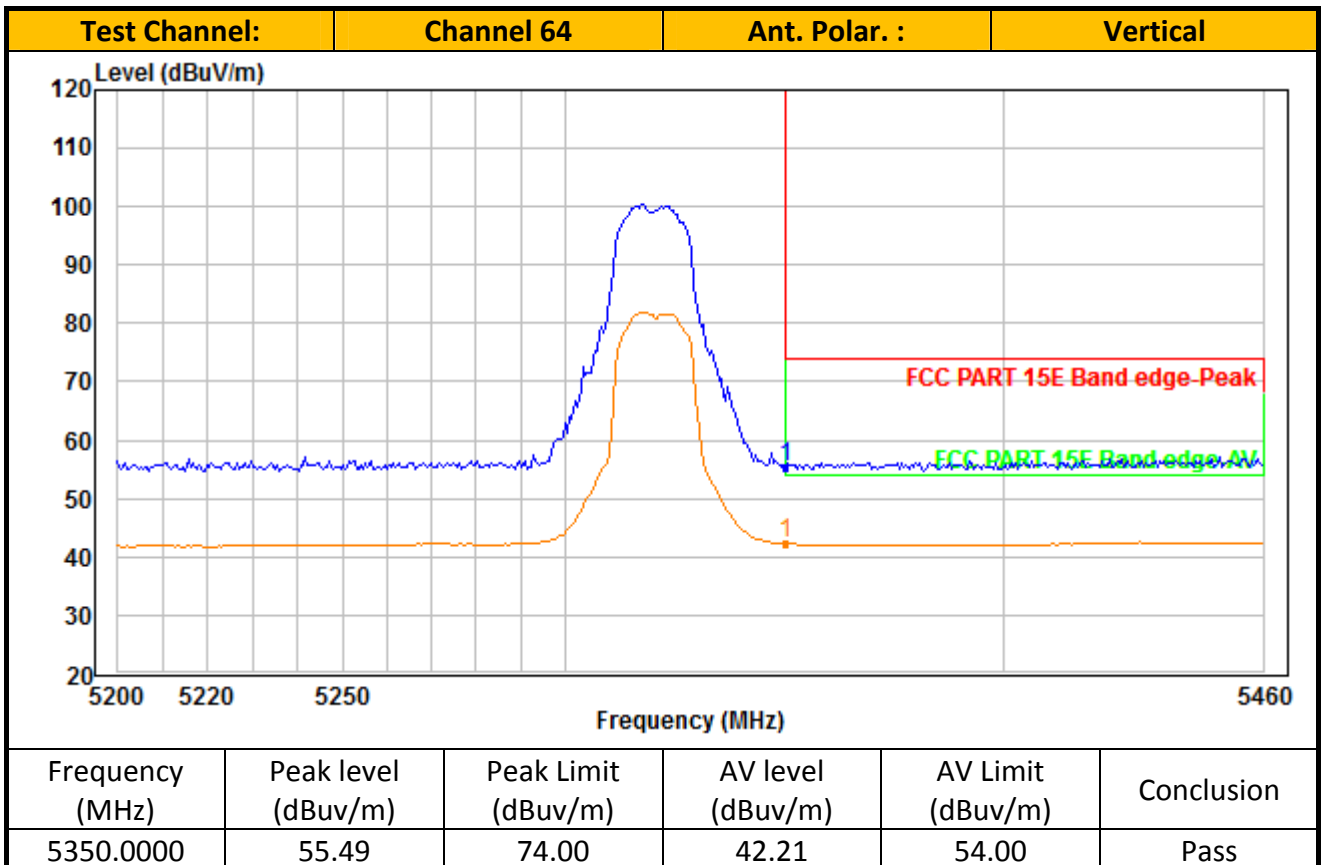
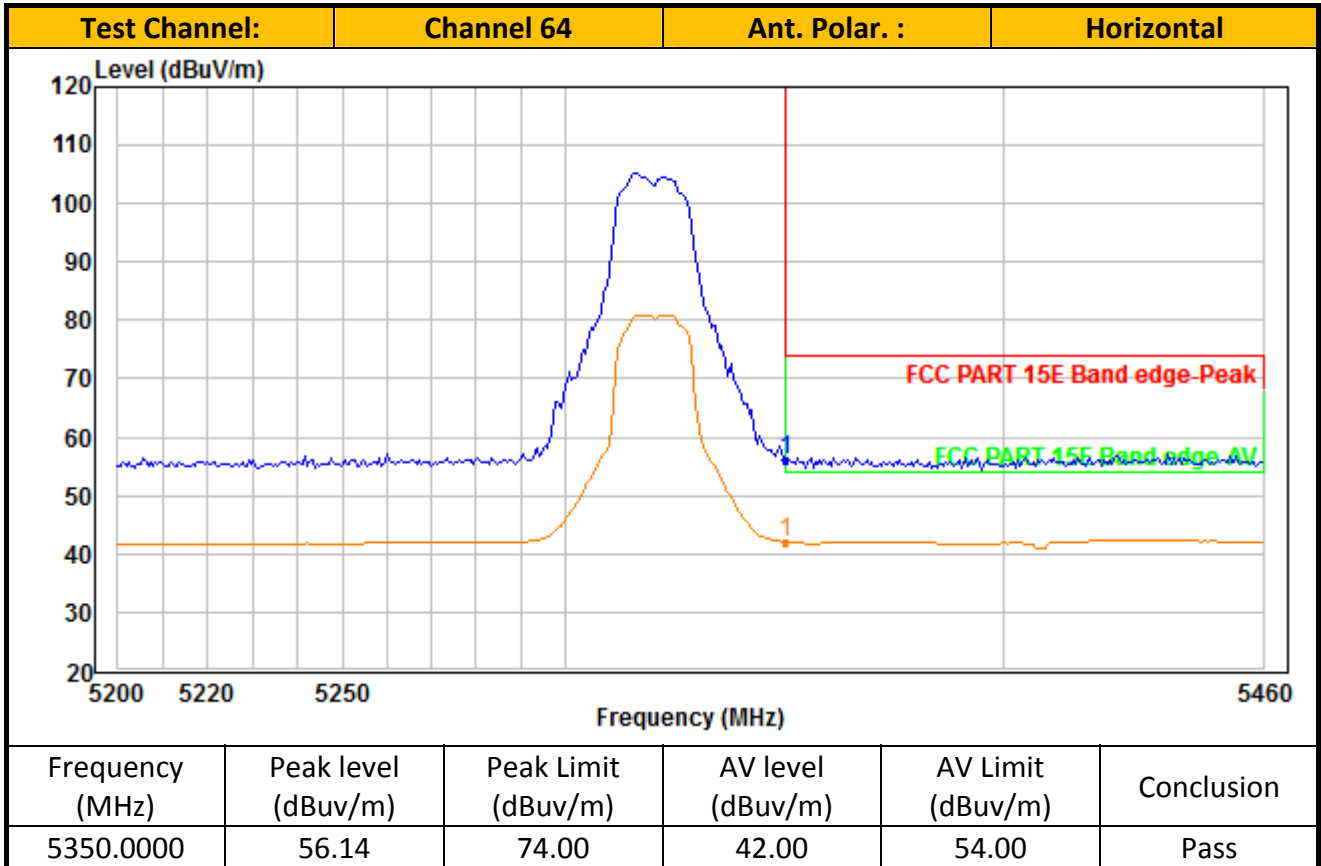

TEST REPORT

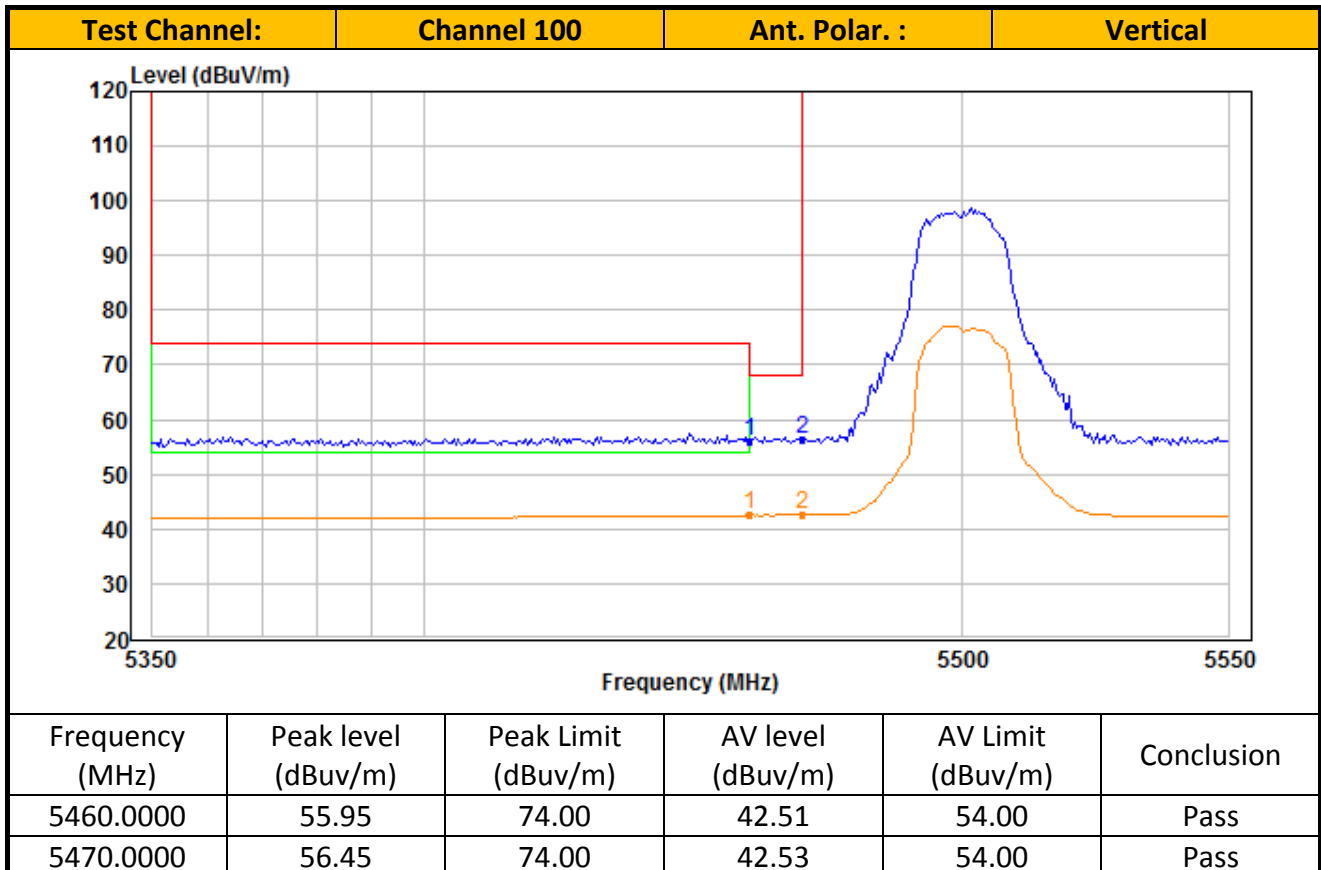
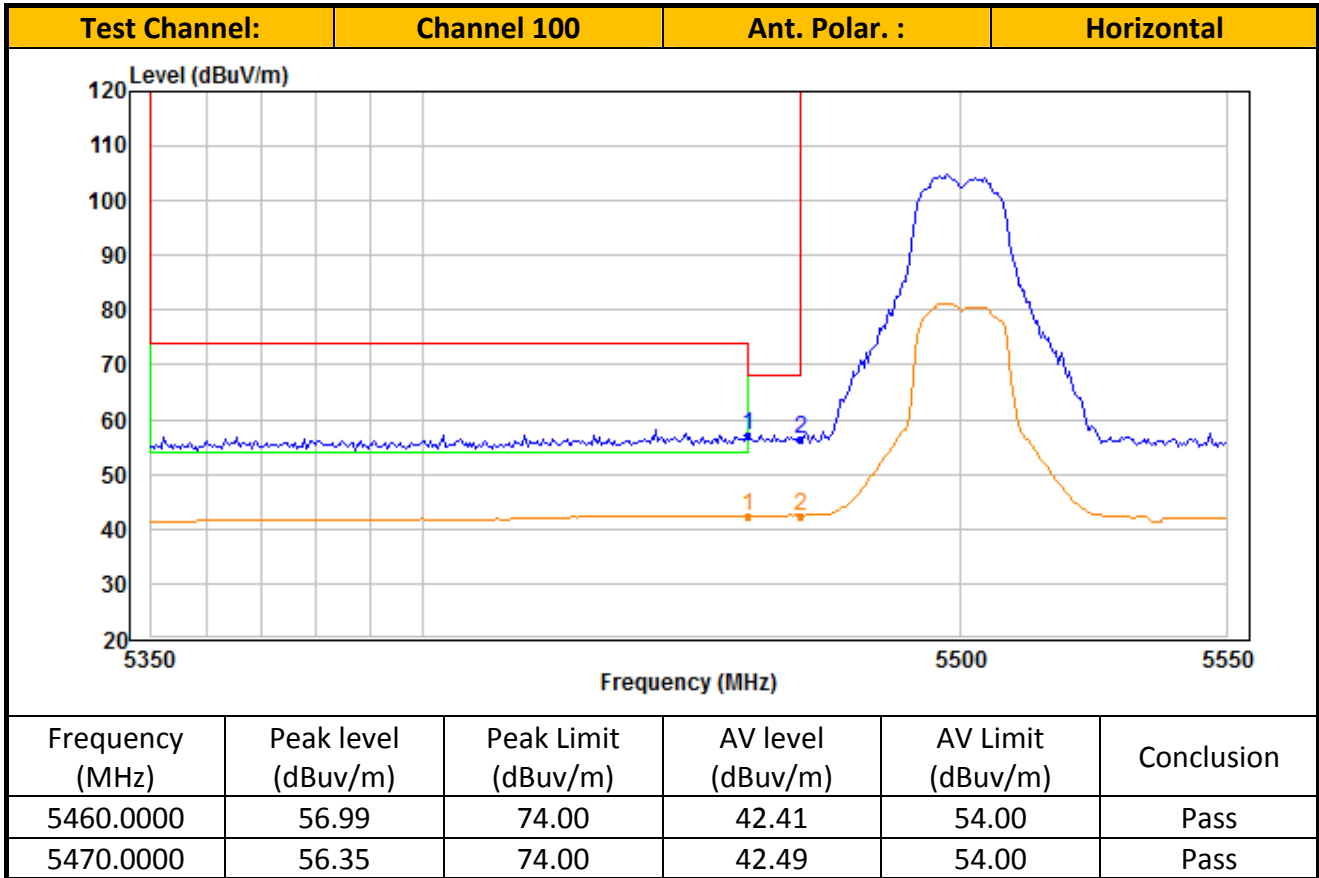

TEST REPORT

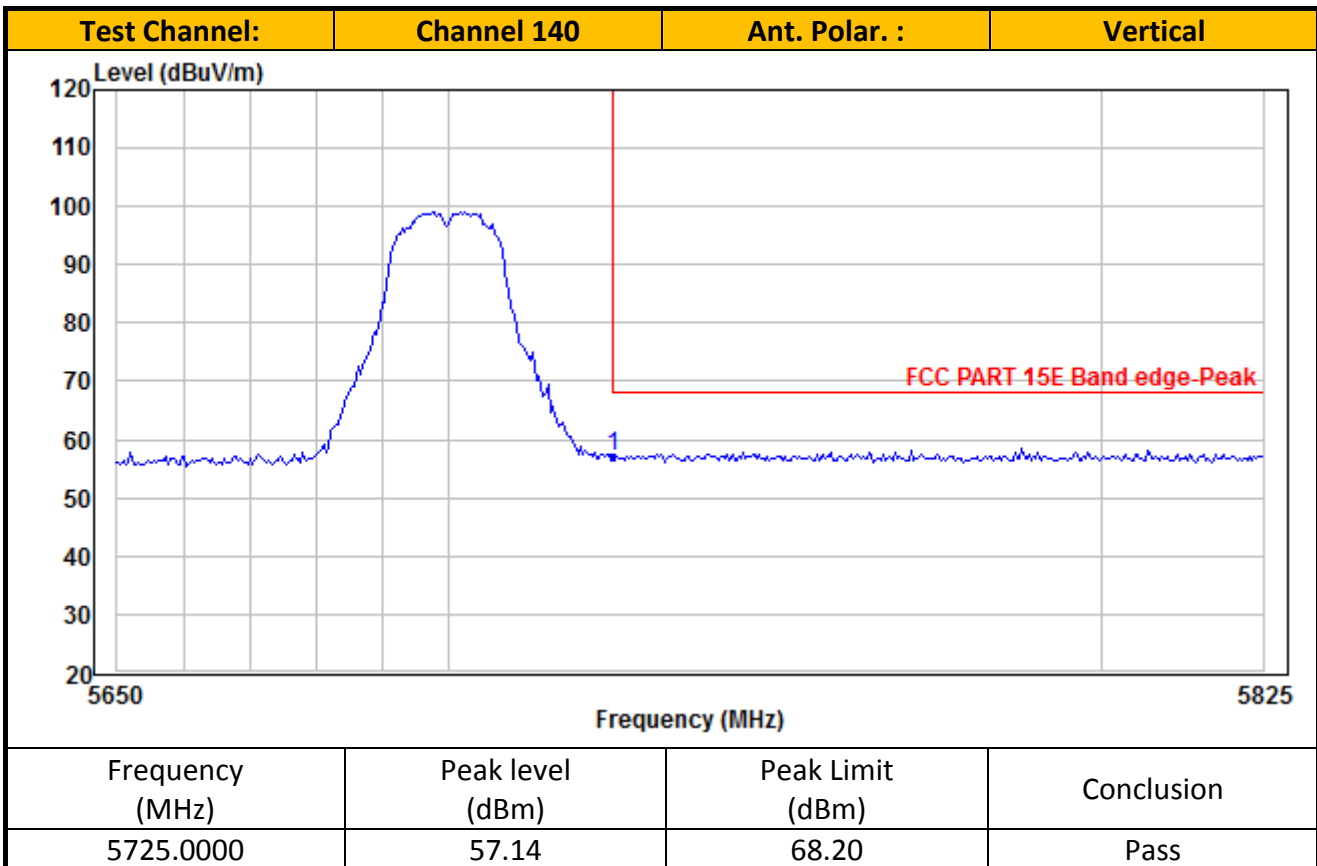
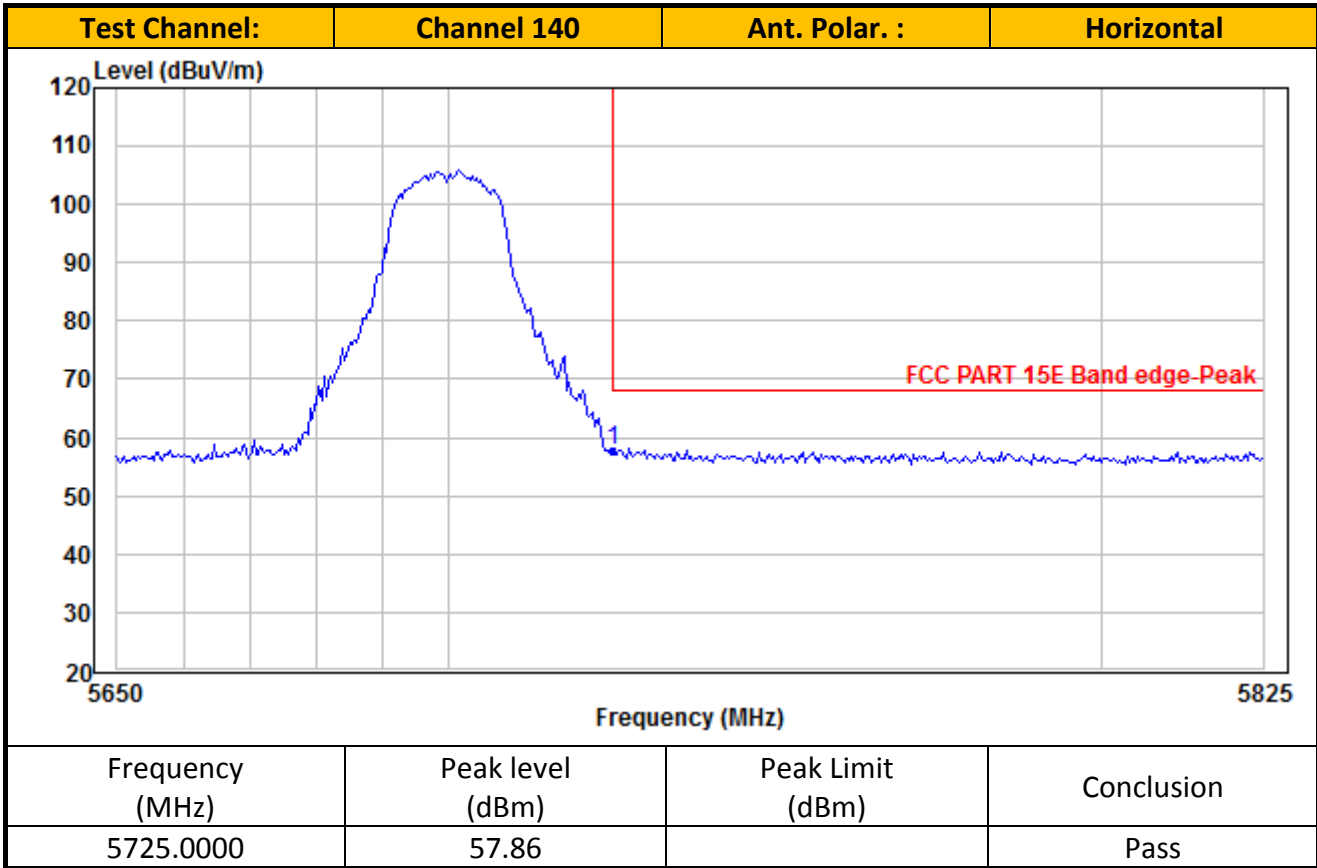

TEST REPORT

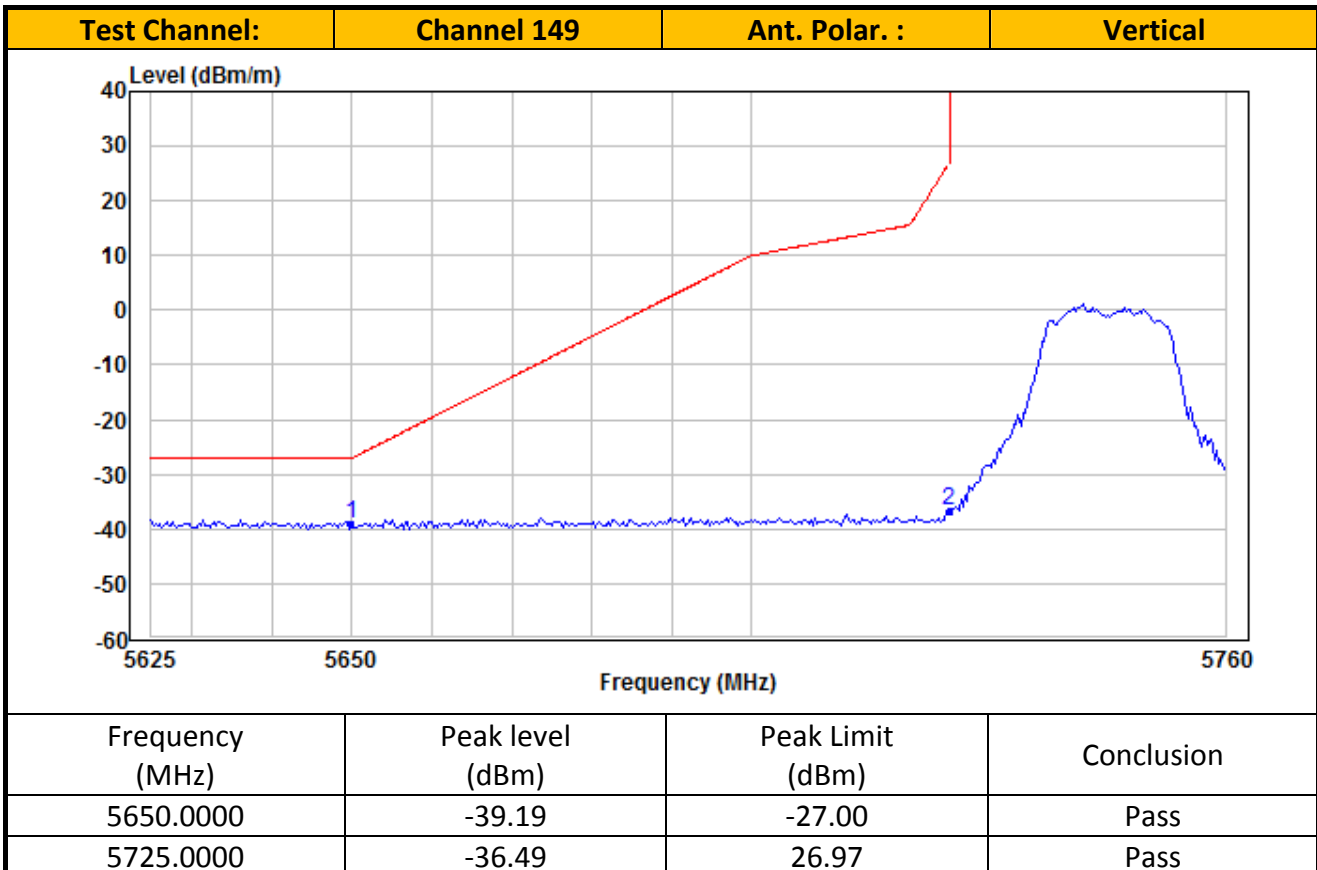
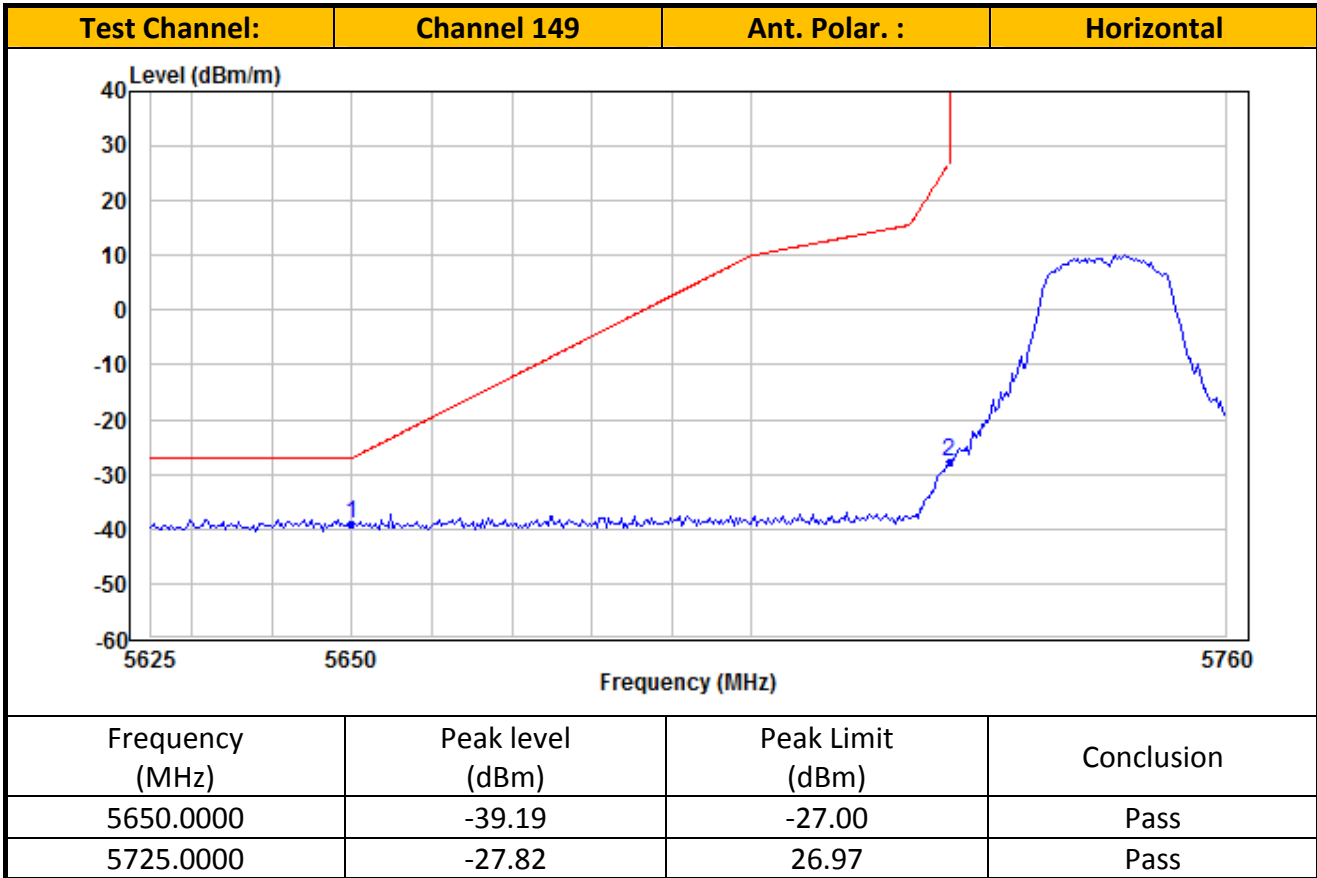

TEST REPORT

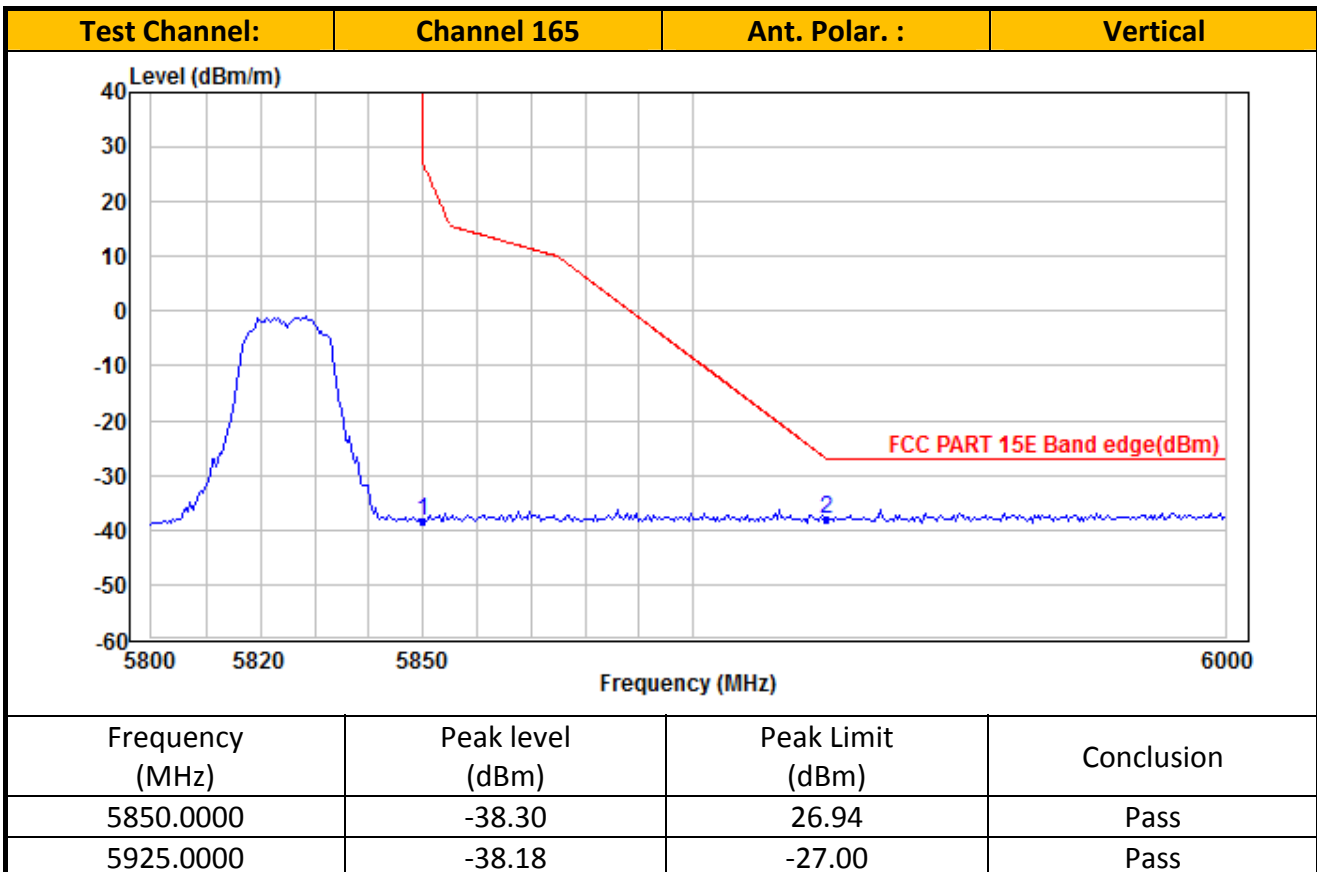
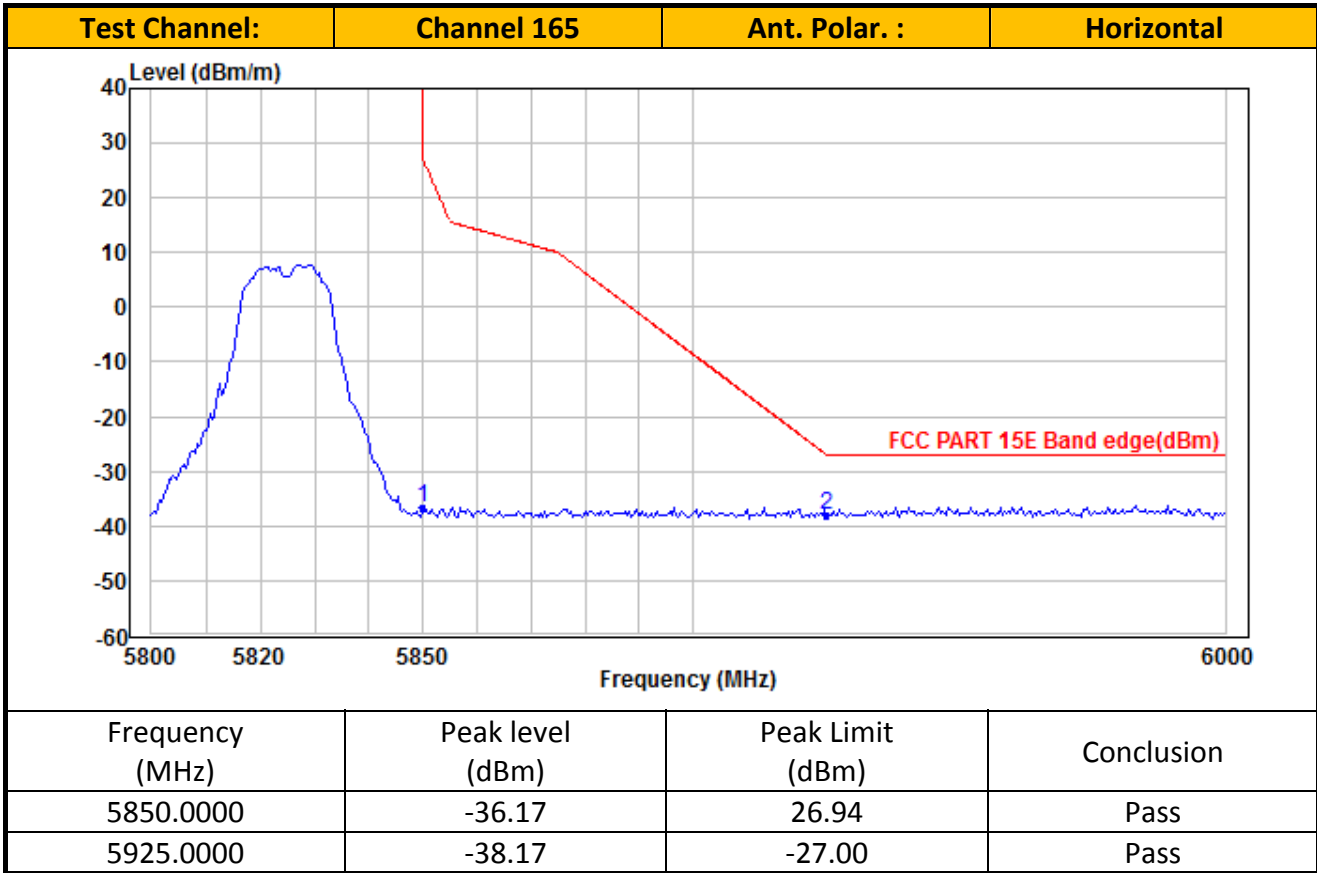

TEST REPORT

Ant. 2_ IEEE 802.11A (20MHz) (OFDM,6MBs)

Radiated Emission Test Data (Above 1GHz):

IEEE 802.11a_Channel 36

No.	Frequency (MHz)	Reading (dBuV/m)	Correction factor (dB)	Result (dBuV/m)	Limit (dBuV/m)	Margin (dB)	Detector	Antenna Polaxis
1	10360.00	39.39	11.11	50.50	74.00	23.50	Peak	Horizontal
2	10360.00	27.60	11.11	38.71	54.00	15.29	Average	Horizontal
3	15540.00	47.02	10.76	57.78	74.00	16.22	Peak	Horizontal
4	15540.00	29.96	10.76	40.72	54.00	13.28	Average	Horizontal
5	10360.00	37.98	9.39	47.37	74.00	26.63	Peak	Vertical
6	10360.00	25.74	9.39	35.13	54.00	18.87	Average	Vertical
7	15540.00	41.52	11.59	53.11	74.00	20.89	Peak	Vertical
8	15540.00	26.56	11.59	38.15	54.00	15.85	Average	Vertical

IEEE 802.11a_Channel 44

No.	Frequency (MHz)	Reading (dBuV/m)	Correction factor (dB)	Result (dBuV/m)	Limit (dBuV/m)	Margin (dB)	Detector	Antenna Polaxis
1	10440.00	40.07	11.31	51.38	74.00	22.62	Peak	Horizontal
2	10440.00	27.78	11.31	39.09	54.00	14.91	Average	Horizontal
3	15660.00	47.76	11.00	58.76	74.00	15.24	Peak	Horizontal
4	15660.00	31.13	11.00	42.13	54.00	11.87	Average	Horizontal
5	10440.00	37.57	9.43	47.00	74.00	27.00	Peak	Vertical
6	10440.00	26.30	9.43	35.73	54.00	18.27	Average	Vertical
7	15660.00	37.77	11.93	49.70	74.00	24.30	Peak	Vertical
8	15660.00	26.38	11.93	38.31	54.00	15.69	Average	Vertical

IEEE 802.11a_Channel 48

No.	Frequency (MHz)	Reading (dBuV/m)	Correction factor (dB)	Result (dBuV/m)	Limit (dBuV/m)	Margin (dB)	Detector	Antenna Polaxis
1	10480.00	38.99	11.41	50.40	74.00	23.60	Peak	Horizontal
2	10480.00	27.27	11.41	38.68	54.00	15.32	Average	Horizontal
3	15720.00	47.38	11.08	58.46	74.00	15.54	Peak	Horizontal
4	15720.00	30.33	11.08	41.41	54.00	12.59	Average	Horizontal
5	10480.00	37.84	9.45	47.29	74.00	26.71	Peak	Vertical
6	10480.00	26.02	9.45	35.47	54.00	18.53	Average	Vertical
7	15720.00	43.32	12.05	55.37	74.00	18.63	Peak	Vertical
8	15720.00	25.81	12.05	37.86	54.00	16.14	Average	Vertical

TEST REPORT

IEEE 802.11a_Channel 52

No.	Frequency (MHz)	Reading (dBuV/m)	Correction factor (dB)	Result (dBuV/m)	Limit (dBuV/m)	Margin (dB)	Detector	Antenna Polaxis
1	10520.00	40.50	11.42	51.92	74.00	22.08	Peak	Horizontal
2	10520.00	27.98	11.42	39.40	54.00	14.60	Average	Horizontal
3	15780.00	46.87	11.16	58.03	74.00	15.97	Peak	Horizontal
4	15780.00	27.63	11.16	38.79	54.00	15.21	Average	Horizontal
5	10520.00	37.90	9.43	47.33	74.00	26.67	Peak	Vertical
6	10520.00	25.89	9.43	35.32	54.00	18.68	Average	Vertical
7	15780.00	42.93	12.19	55.12	74.00	18.88	Peak	Vertical
8	15780.00	26.10	12.19	38.29	54.00	15.71	Average	Vertical

IEEE 802.11a_Channel 60

No.	Frequency (MHz)	Reading (dBuV/m)	Correction factor (dB)	Result (dBuV/m)	Limit (dBuV/m)	Margin (dB)	Detector	Antenna Polaxis
1	10600.00	41.06	11.33	52.39	74.00	21.61	Peak	Horizontal
2	10600.00	28.32	11.33	39.65	54.00	14.35	Average	Horizontal
3	15900.00	42.83	11.33	54.16	74.00	19.84	Peak	Horizontal
4	15900.00	26.19	11.33	37.52	54.00	16.48	Average	Horizontal
5	10600.00	38.69	9.37	48.06	74.00	25.94	Peak	Vertical
6	10600.00	26.56	9.37	35.93	54.00	18.07	Average	Vertical
7	15900.00	37.65	12.45	50.10	74.00	23.90	Peak	Vertical
8	15900.00	25.63	12.45	38.08	54.00	15.92	Average	Vertical

IEEE 802.11a_Channel 64

No.	Frequency (MHz)	Reading (dBuV/m)	Correction factor (dB)	Result (dBuV/m)	Limit (dBuV/m)	Margin (dB)	Detector	Antenna Polaxis
1	10640.00	40.29	11.29	51.58	74.00	22.42	Peak	Horizontal
2	10640.00	28.14	11.29	39.43	54.00	14.57	Average	Horizontal
3	15960.00	42.43	11.49	53.92	74.00	20.08	Peak	Horizontal
4	15960.00	26.72	11.49	38.21	54.00	15.79	Average	Horizontal
5	10640.00	38.02	9.34	47.36	74.00	26.64	Peak	Vertical
6	10640.00	26.59	9.34	35.93	54.00	18.07	Average	Vertical
7	15960.00	37.13	12.66	49.79	74.00	24.21	Peak	Vertical
8	15960.00	25.18	12.66	37.84	54.00	16.16	Average	Vertical

TEST REPORT

IEEE 802.11a_Channel 100

No.	Frequency (MHz)	Reading (dBuV/m)	Correction factor (dB)	Result (dBuV/m)	Limit (dBuV/m)	Margin (dB)	Detector	Antenna Polaxis
1	11000.00	40.39	10.30	50.69	74.00	23.31	Peak	Horizontal
2	11000.00	28.83	10.30	39.13	54.00	14.87	Average	Horizontal
3	16500.00	42.40	13.35	55.75	74.00	18.25	Peak	Horizontal
4	16500.00	26.44	13.35	39.79	54.00	14.21	Average	Horizontal
5	11000.00	40.76	8.50	49.26	74.00	24.74	Peak	Vertical
6	11000.00	28.35	8.50	36.85	54.00	17.15	Average	Vertical
7	16500.00	43.82	13.45	57.27	74.00	16.73	Peak	Vertical
8	16500.00	24.43	13.45	37.88	54.00	16.12	Average	Vertical

IEEE 802.11a_Channel 116

No.	Frequency (MHz)	Reading (dBuV/m)	Correction factor (dB)	Result (dBuV/m)	Limit (dBuV/m)	Margin (dB)	Detector	Antenna Polaxis
1	11160.00	40.90	9.97	50.87	74.00	23.13	Peak	Horizontal
2	11160.00	28.26	9.97	38.23	54.00	15.77	Average	Horizontal
3	16740.00	44.96	13.24	58.20	74.00	15.80	Peak	Horizontal
4	16740.00	28.16	13.24	41.40	54.00	12.60	Average	Horizontal
5	11160.00	40.19	8.27	48.46	74.00	25.54	Peak	Vertical
6	11160.00	27.35	8.27	35.62	54.00	18.38	Average	Vertical
7	16740.00	38.92	13.01	51.93	74.00	22.07	Peak	Vertical
8	16740.00	25.66	13.01	38.67	54.00	15.33	Average	Vertical

IEEE 802.11a_Channel 140

No.	Frequency (MHz)	Reading (dBuV/m)	Correction factor (dB)	Result (dBuV/m)	Limit (dBuV/m)	Margin (dB)	Detector	Antenna Polaxis
1	11400.00	41.34	9.86	51.20	74.00	22.80	Peak	Horizontal
2	11400.00	29.40	9.86	39.26	54.00	14.74	Average	Horizontal
3	17100.00	38.98	13.42	52.40	74.00	21.60	Peak	Horizontal
4	17100.00	26.26	13.42	39.68	54.00	14.32	Average	Horizontal
5	11400.00	41.86	8.30	50.16	74.00	23.84	Peak	Vertical
6	11400.00	28.89	8.30	37.19	54.00	16.81	Average	Vertical
7	17100.00	36.40	12.76	49.16	74.00	24.84	Peak	Vertical
8	17100.00	24.05	12.76	36.81	54.00	17.19	Average	Vertical

TEST REPORT

IEEE 802.11a_Channel 149

No.	Frequency (MHz)	Reading (dBuV/m)	Correction factor (dB)	Result (dBuV/m)	Limit (dBuV/m)	Margin (dB)	Detector	Antenna Polaxis
1	11490.00	41.72	9.78	51.50	74.00	22.50	Peak	Horizontal
2	11490.00	28.80	9.78	38.58	54.00	15.42	Average	Horizontal
3	17235.00	38.95	13.98	52.93	74.00	21.07	Peak	Horizontal
4	17235.00	26.16	13.98	40.14	54.00	13.86	Average	Horizontal
5	11490.00	41.89	8.27	50.16	74.00	23.84	Peak	Vertical
6	11490.00	28.63	8.27	36.90	54.00	17.10	Average	Vertical
7	17235.00	37.99	13.24	51.23	74.00	22.77	Peak	Vertical
8	17235.00	25.76	13.24	39.00	54.00	15.00	Average	Vertical

IEEE 802.11a_Channel 157

No.	Frequency (MHz)	Reading (dBuV/m)	Correction factor (dB)	Result (dBuV/m)	Limit (dBuV/m)	Margin (dB)	Detector	Antenna Polaxis
1	11570.00	41.21	9.86	51.07	74.00	22.93	Peak	Horizontal
2	11570.00	28.59	9.86	38.45	54.00	15.55	Average	Horizontal
3	17355.00	39.88	14.49	54.37	74.00	19.63	Peak	Horizontal
4	17355.00	27.48	14.49	41.97	54.00	12.03	Average	Horizontal
5	11570.00	41.45	8.47	49.92	74.00	24.08	Peak	Vertical
6	11570.00	28.07	8.47	36.54	54.00	17.46	Average	Vertical
7	17355.00	39.11	13.68	52.79	74.00	21.21	Peak	Vertical
8	17355.00	27.15	13.68	40.83	54.00	13.17	Average	Vertical

IEEE 802.11a_Channel 165

No.	Frequency (MHz)	Reading (dBuV/m)	Correction factor (dB)	Result (dBuV/m)	Limit (dBuV/m)	Margin (dB)	Detector	Antenna Polaxis
1	11650.00	40.54	9.95	50.49	74.00	23.51	Peak	Horizontal
2	11650.00	28.53	9.95	38.48	54.00	15.52	Average	Horizontal
3	17475.00	39.53	14.89	54.42	74.00	19.58	Peak	Horizontal
4	17475.00	27.38	14.89	42.27	54.00	11.73	Average	Horizontal
5	11650.00	40.60	8.69	49.29	74.00	24.71	Peak	Vertical
6	11650.00	28.38	8.69	37.07	54.00	16.93	Average	Vertical
7	17475.00	38.28	14.00	52.28	74.00	21.72	Peak	Vertical
8	17475.00	26.47	14.00	40.47	54.00	13.53	Average	Vertical

TEST REPORT

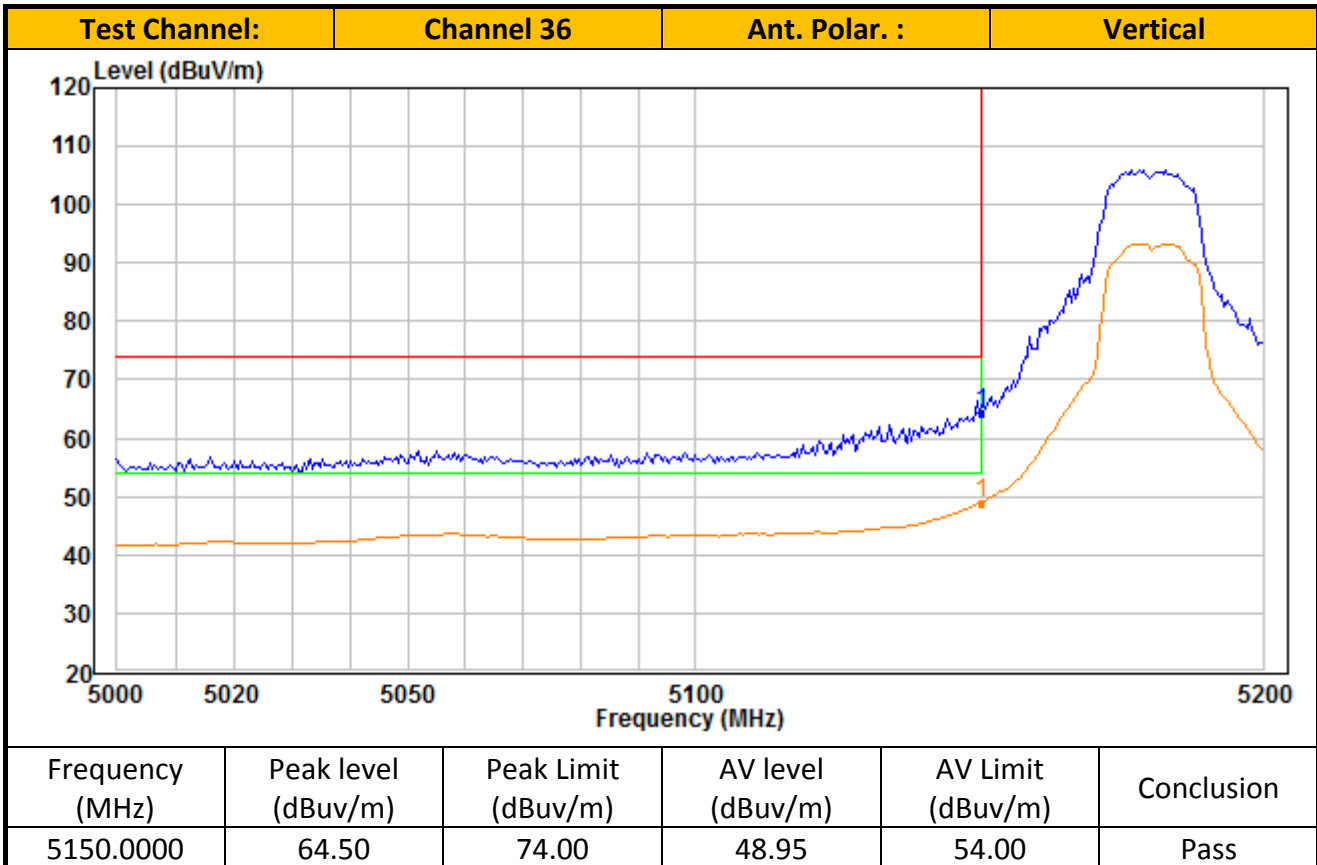
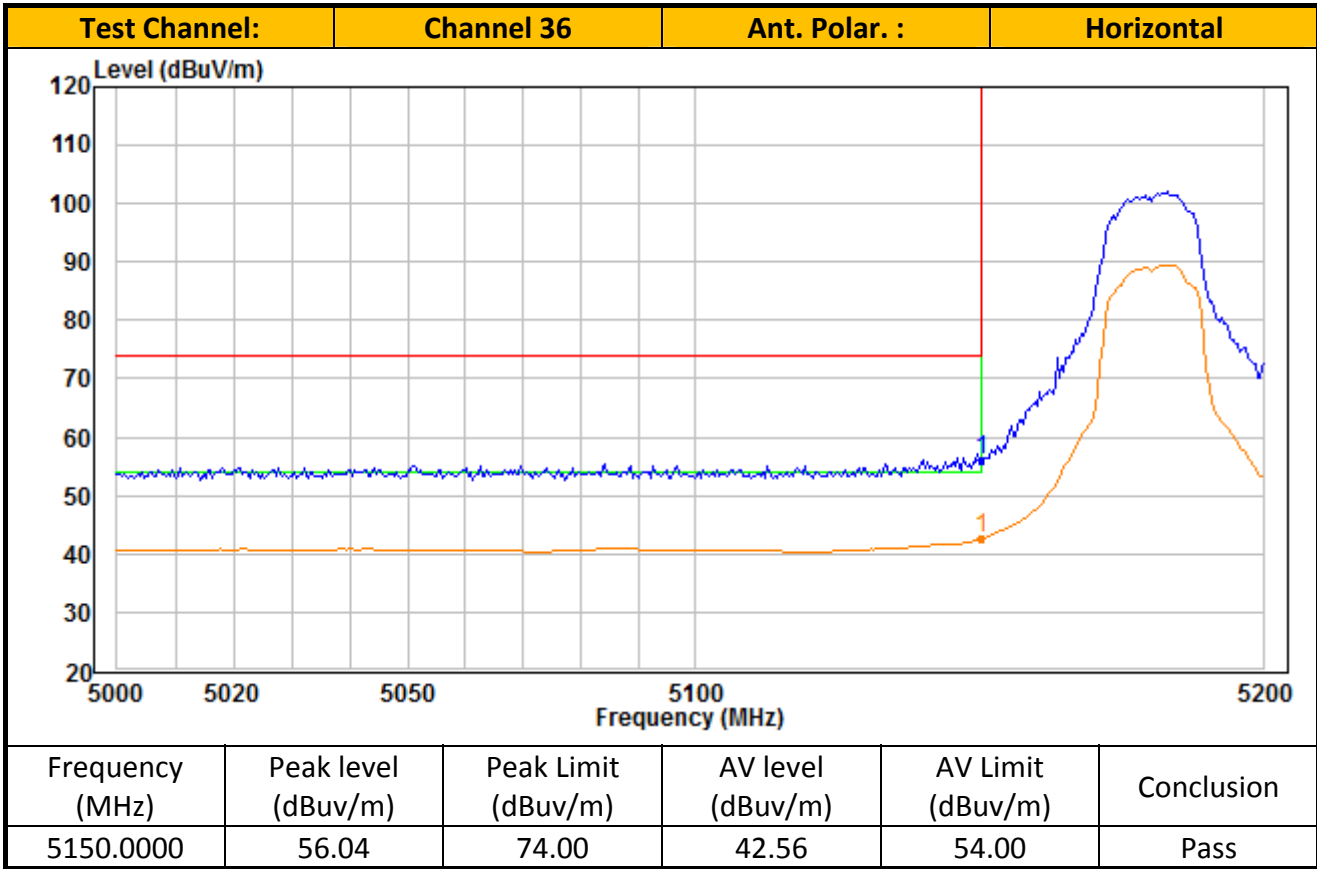

TEST REPORT

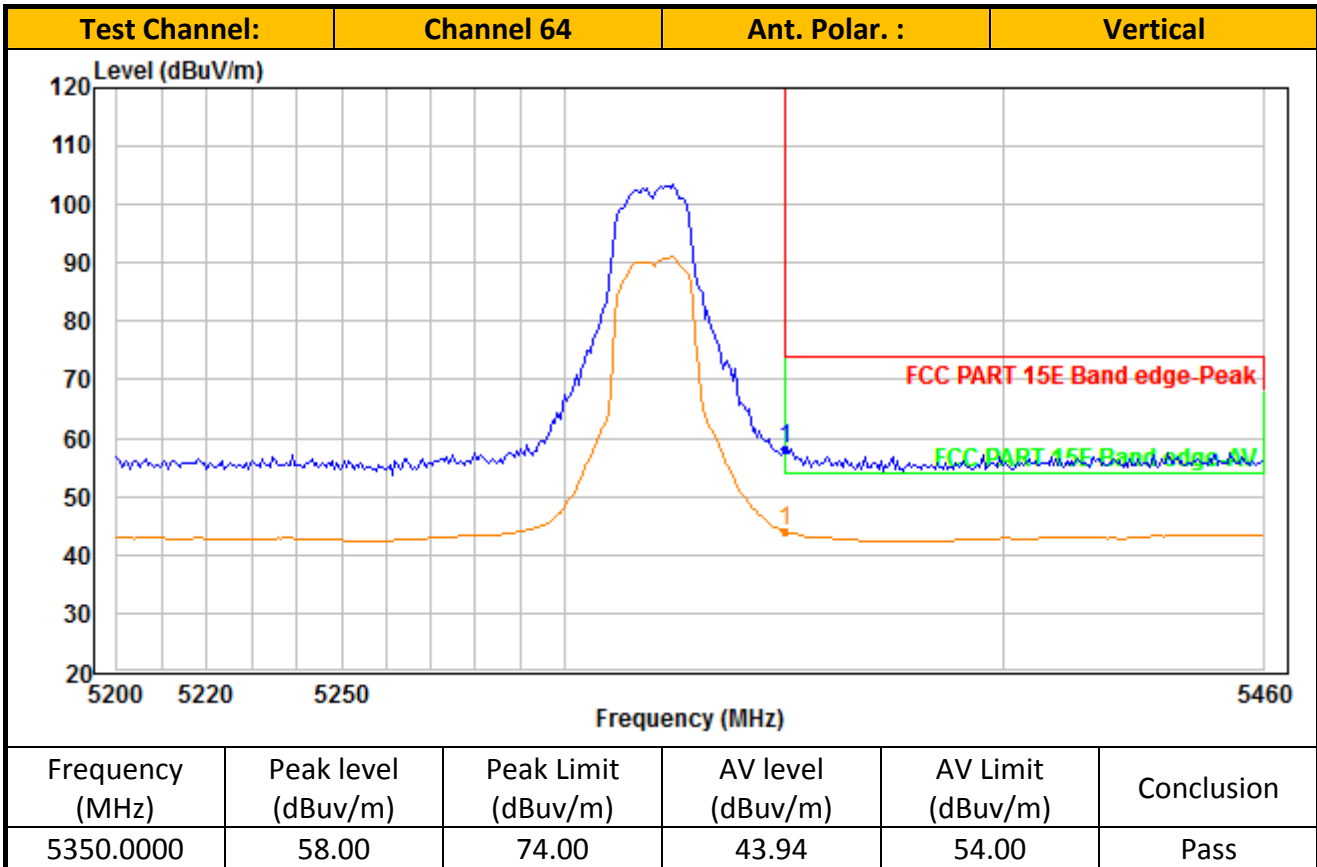
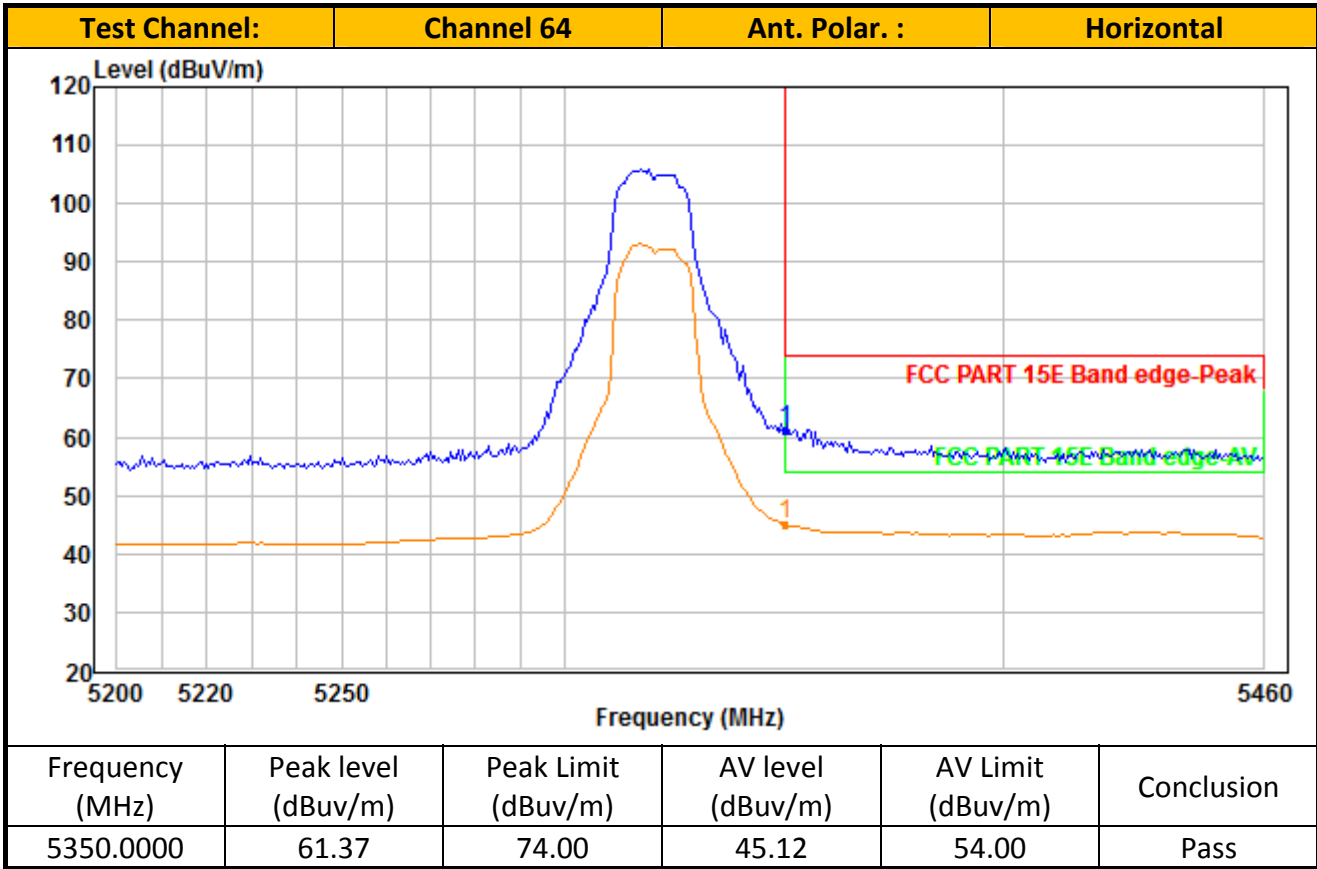

TEST REPORT

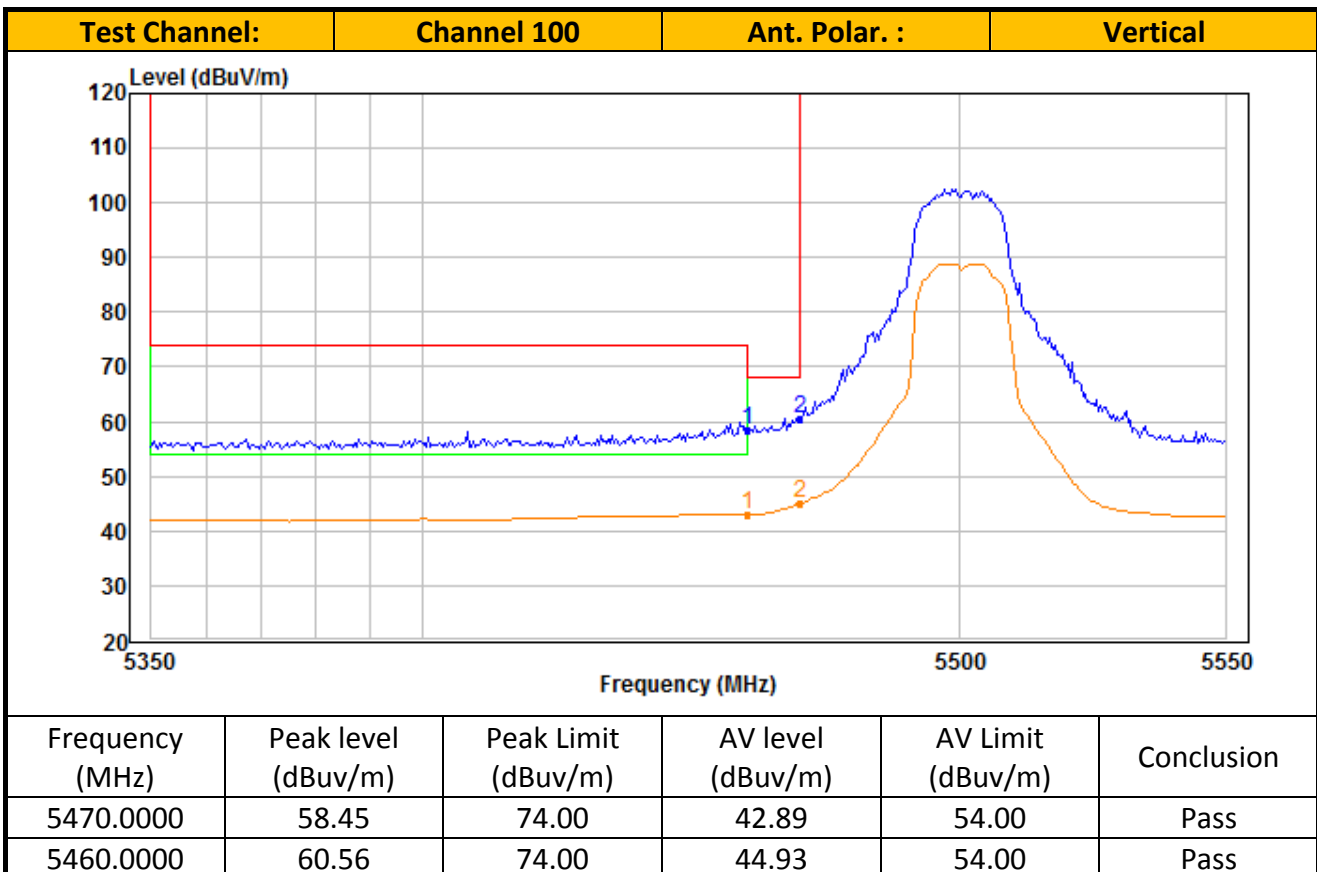
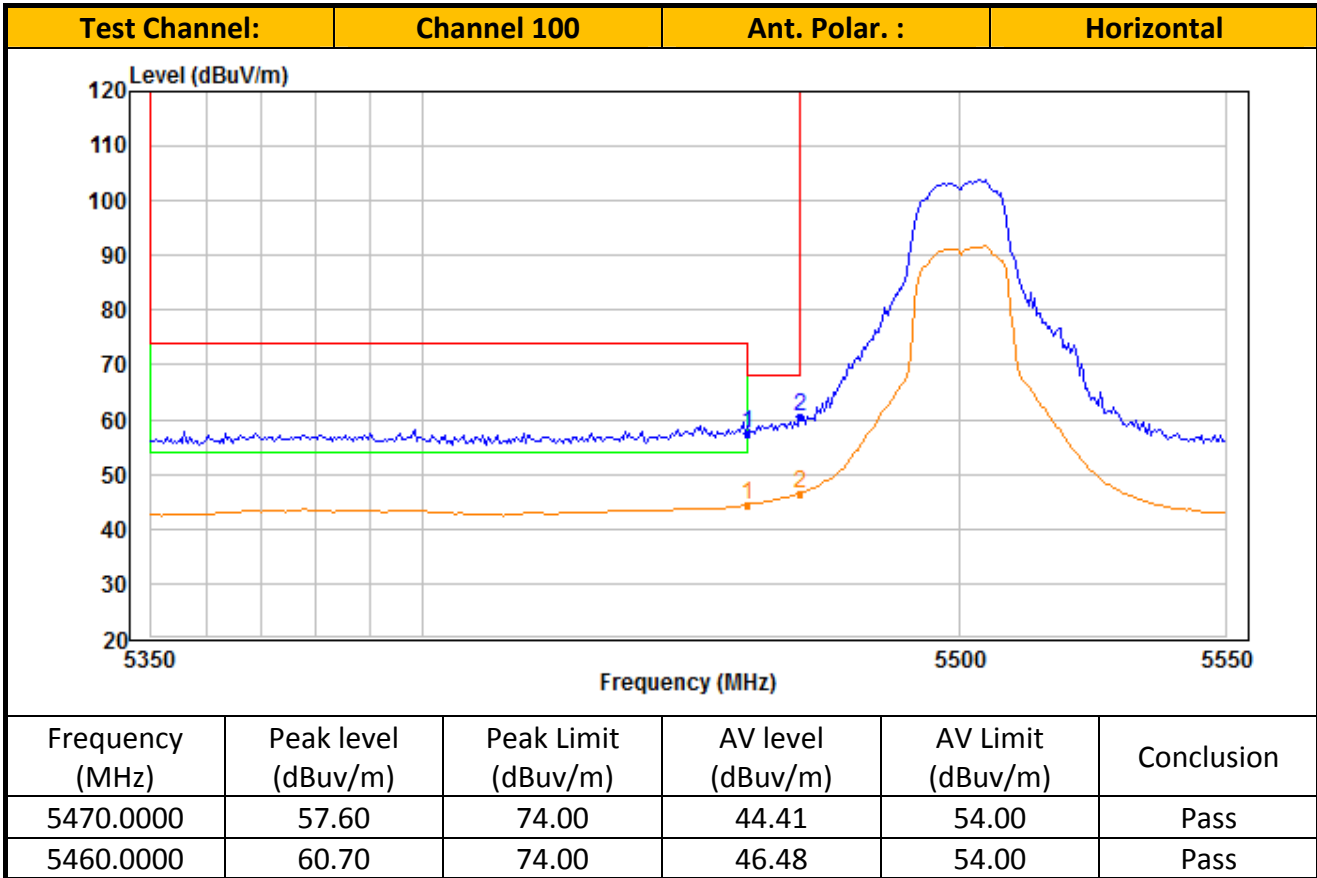

TEST REPORT

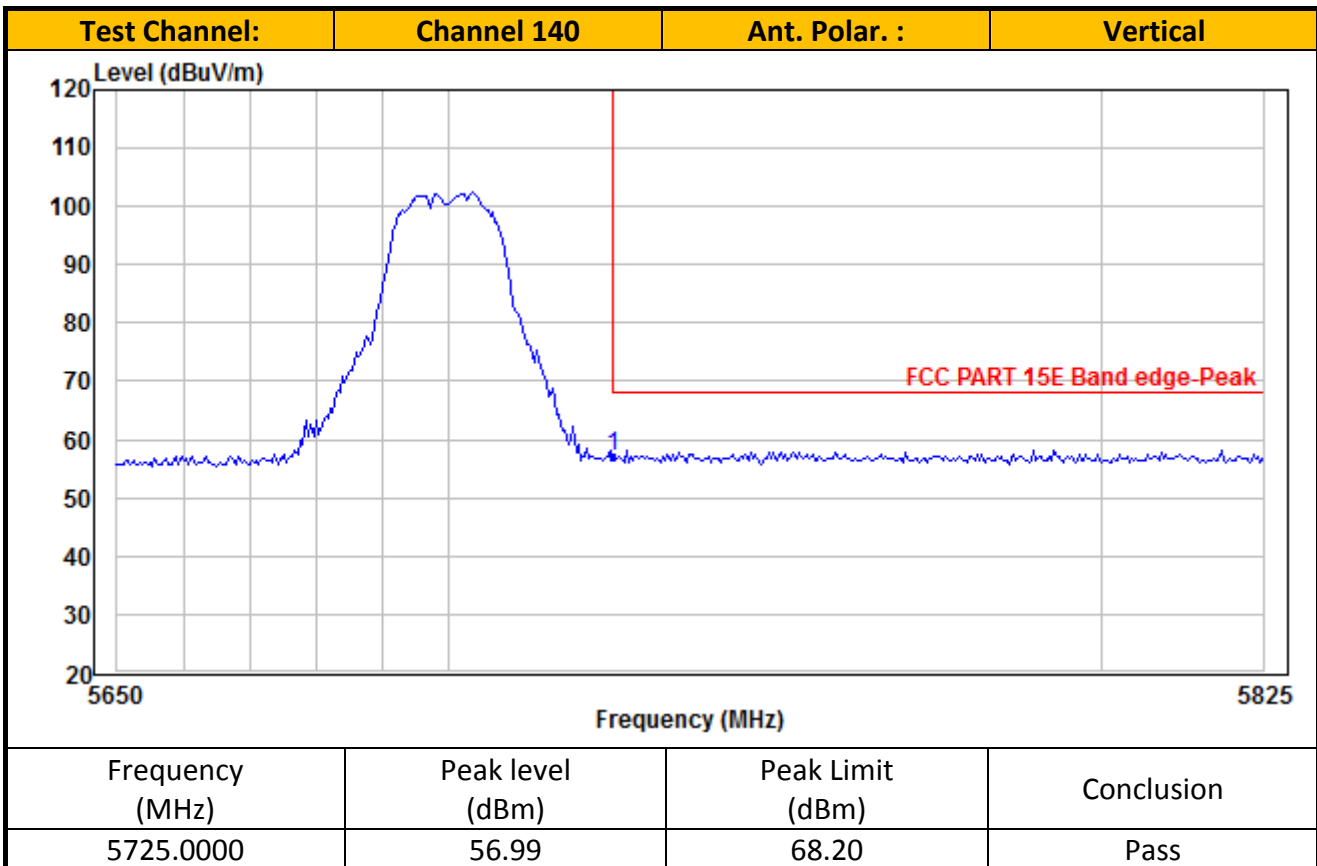
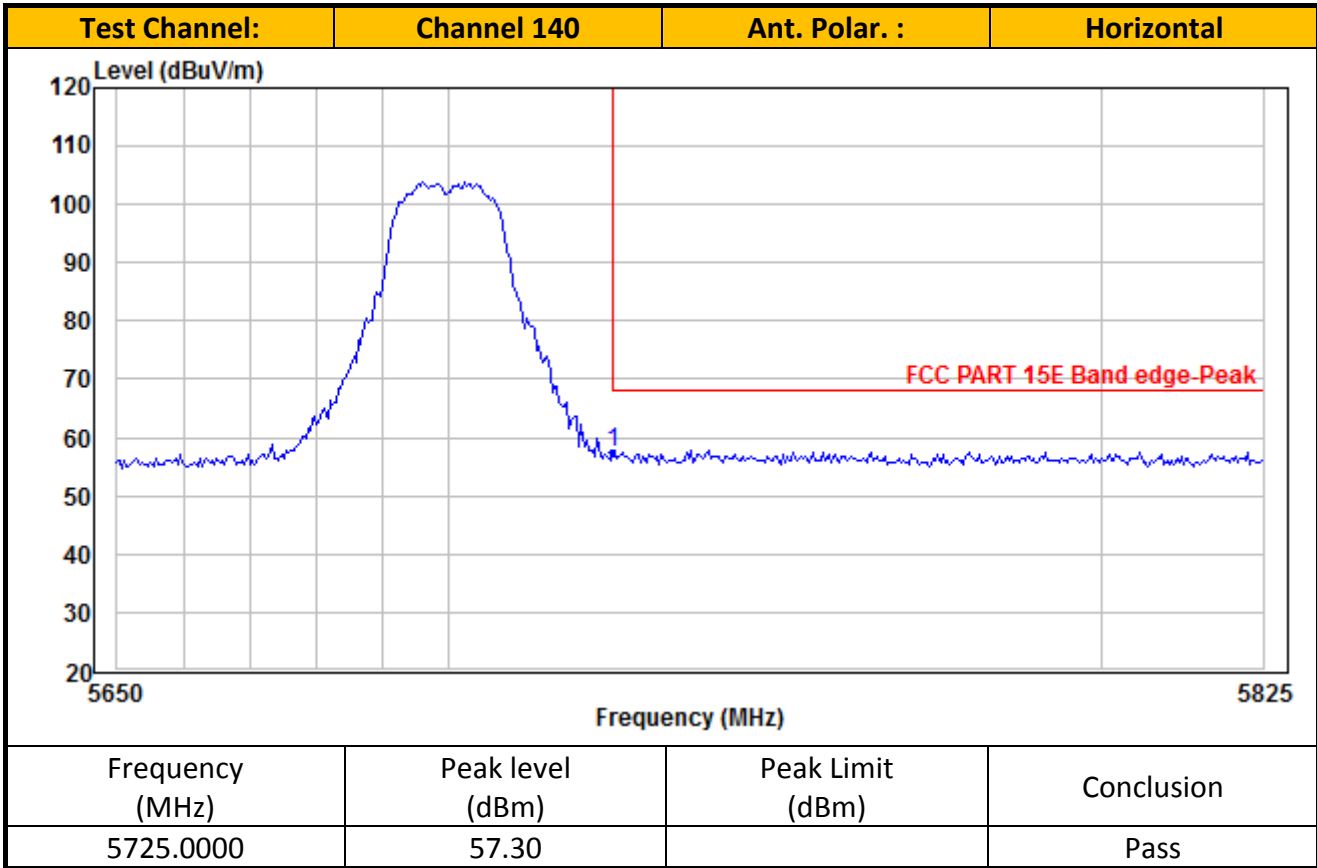

TEST REPORT

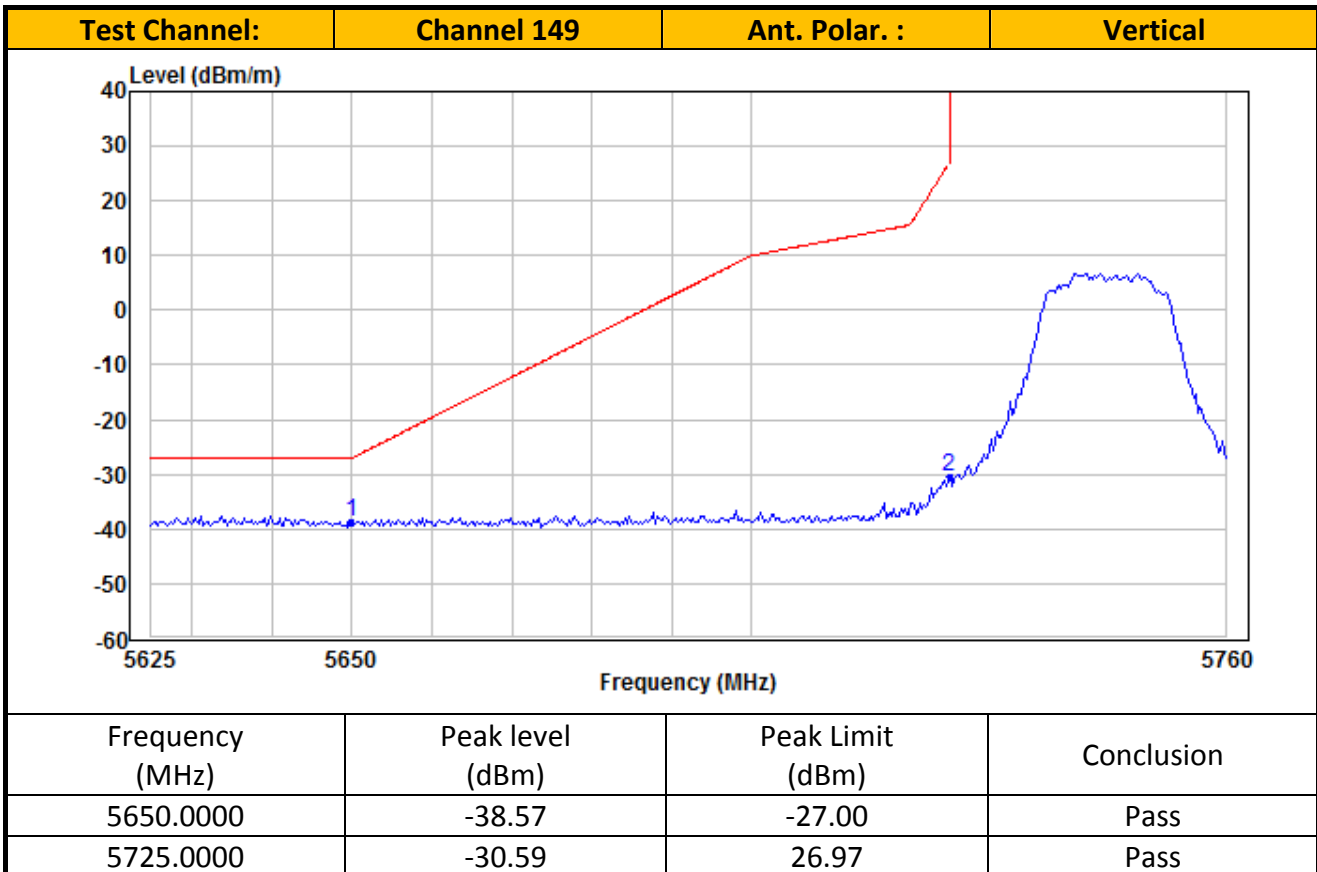
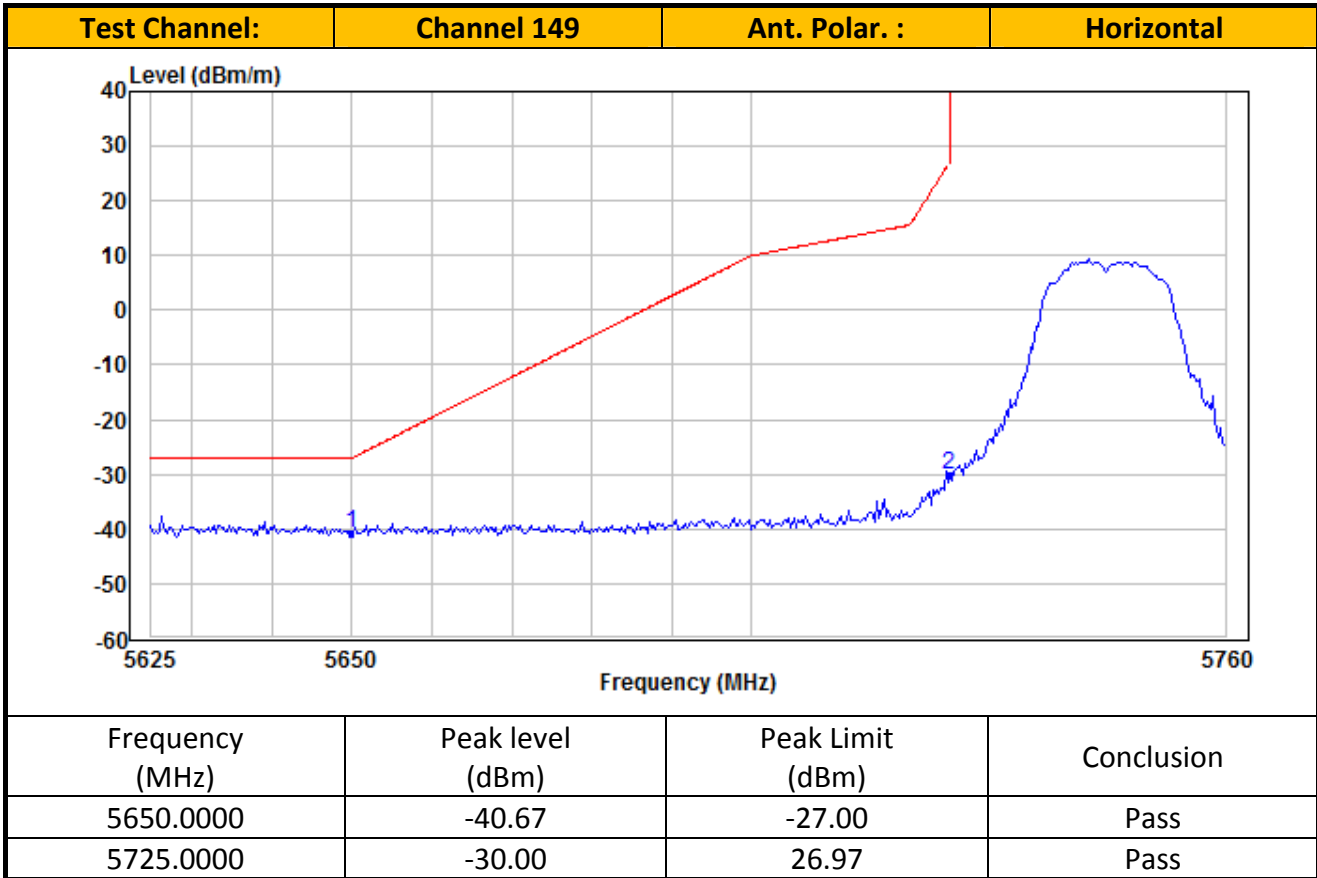

TEST REPORT

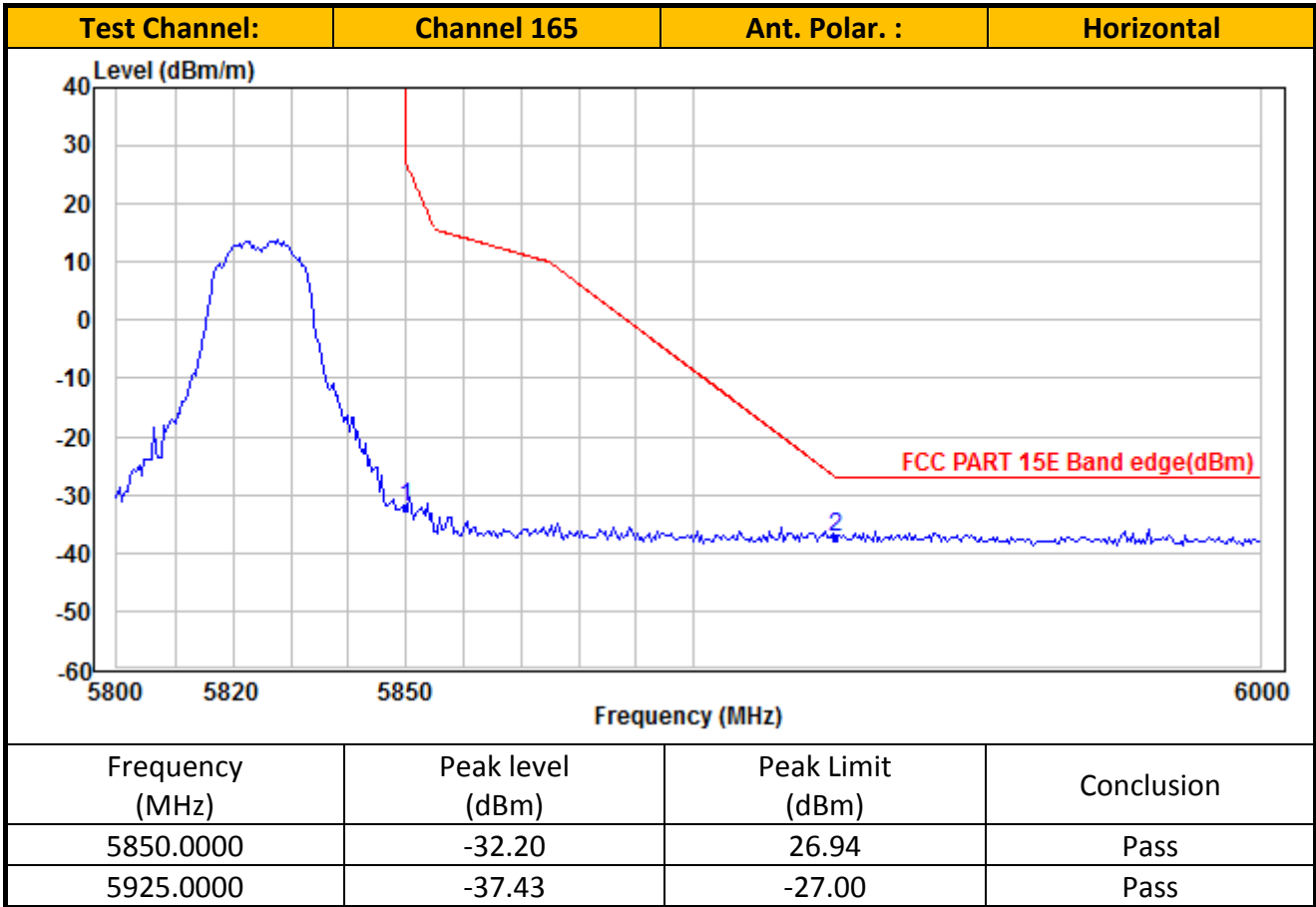

TEST REPORT

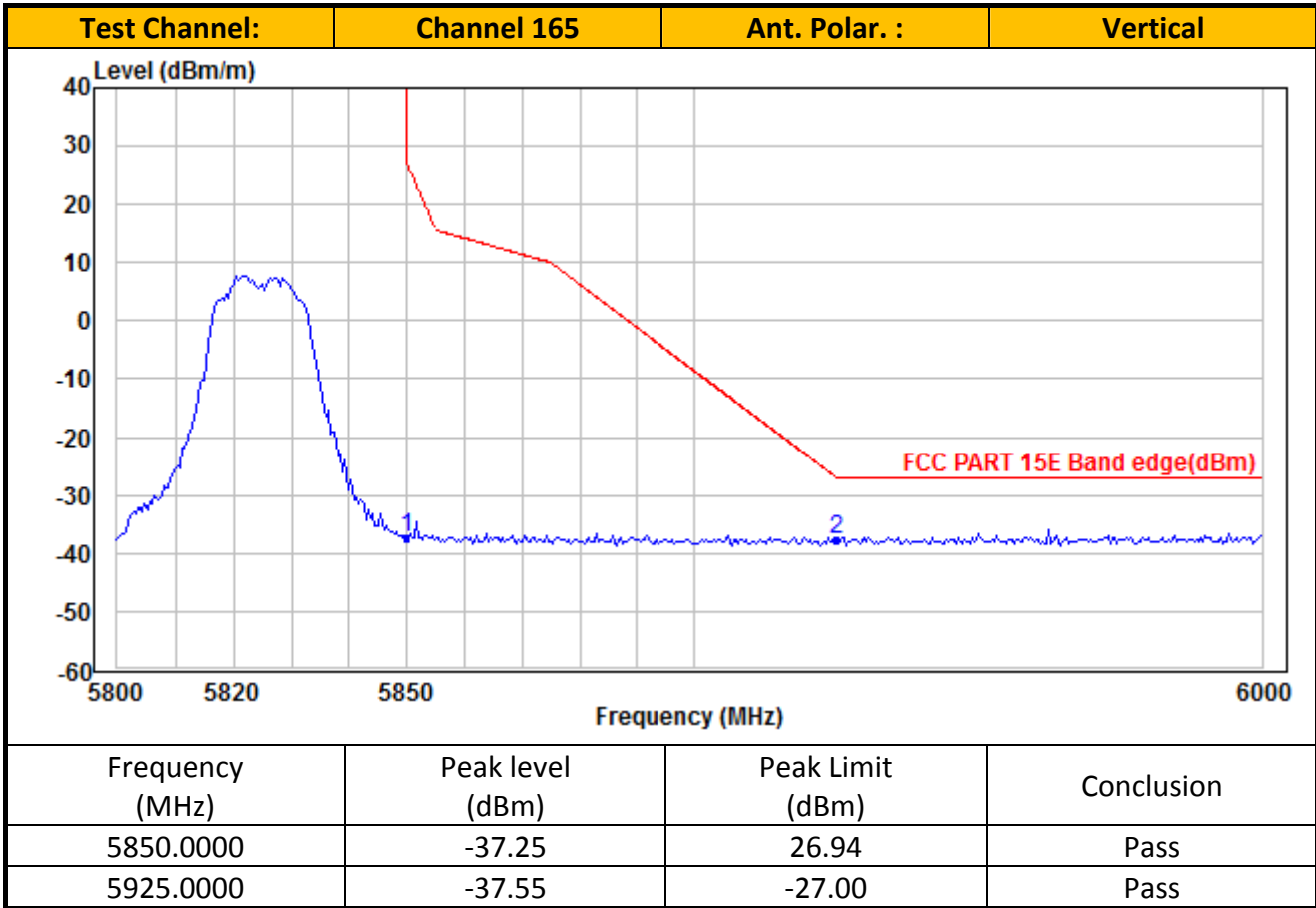

- NOTES:
1. Peak detector is used for the emission measurement.
 1. Average detector is used for the average data of emission measurement
 2. All measurements were made at 3 meters. Radiated emissions not detected at the 3-meter distance were measured at 0.3-meter and an inverse proportional extrapolation was performed to compare the signal level to the 3-meter limit. No other radiated emissions than those reported were detected at a test distance of 0.3-meter.
 3. Value in the margin column shows emission below limit.
 4. Horn antenna is used for the emission over 1000MHz.
 6. Emission (the row indicated by ***bold italic***) within the restricted band meets the requirement of FCC Part 15 Section 15.205.
 7. For the measurement of radiated emission, summation method was used which numerical integrating (in terms of linear power) over the transmitter occupied bandwidth.
 8. For the linear power measurement, data in 1MHz spacing was collected by spectrum analyzer with 1MHz resolution bandwidth.

TEST REPORT

Ant. 1_ IEEE 802.11N (20MHz) (MCS0)

Radiated Emission Test Data (Above 1GHz):

IEEE 802.11n-HT20_Channel 36

No.	Frequency (MHz)	Reading (dBuV/m)	Correction factor (dB)	Result (dBuV/m)	Limit (dBuV/m)	Margin (dB)	Detector	Antenna Polaxis
1	10360.00	40.58	11.11	51.69	74.00	22.31	Peak	Horizontal
2	10360.00	28.68	11.11	39.79	54.00	14.21	Average	Horizontal
3	15540.00	41.45	10.76	52.21	74.00	21.79	Peak	Horizontal
4	15540.00	25.96	10.76	36.72	54.00	17.28	Average	Horizontal
5	10360.00	39.18	9.39	48.57	74.00	25.43	Peak	Vertical
6	10360.00	27.53	9.39	36.92	54.00	17.08	Average	Vertical
7	15540.00	45.62	11.59	57.21	74.00	16.79	Peak	Vertical
8	15540.00	28.21	11.59	39.80	54.00	14.20	Average	Vertical

IEEE 802.11n-HT20_Channel 44

No.	Frequency (MHz)	Reading (dBuV/m)	Correction factor (dB)	Result (dBuV/m)	Limit (dBuV/m)	Margin (dB)	Detector	Antenna Polaxis
1	10440.00	40.14	11.31	51.45	74.00	22.55	Peak	Horizontal
2	10440.00	28.68	11.31	39.99	54.00	14.01	Average	Horizontal
3	15660.00	43.91	11.00	54.91	74.00	19.09	Peak	Horizontal
4	15660.00	29.02	11.00	40.02	54.00	13.98	Average	Horizontal
5	10440.00	38.55	9.43	47.98	74.00	26.02	Peak	Vertical
6	10440.00	26.67	9.43	36.10	54.00	17.90	Average	Vertical
7	15660.00	44.45	11.93	56.38	74.00	17.62	Peak	Vertical
8	15660.00	28.45	11.93	40.38	54.00	13.62	Average	Vertical

IEEE 802.11n-HT20_Channel 48

No.	Frequency (MHz)	Reading (dBuV/m)	Correction factor (dB)	Result (dBuV/m)	Limit (dBuV/m)	Margin (dB)	Detector	Antenna Polaxis
1	10480.00	40.77	11.41	52.18	74.00	21.82	Peak	Horizontal
2	10480.00	28.05	11.41	39.46	54.00	14.54	Average	Horizontal
3	15720.00	41.89	11.08	52.97	74.00	21.03	Peak	Horizontal
4	15720.00	25.62	11.08	36.70	54.00	17.30	Average	Horizontal
5	10480.00	38.47	9.45	47.92	74.00	26.08	Peak	Vertical
6	10480.00	26.71	9.45	36.16	54.00	17.84	Average	Vertical
7	15720.00	45.48	12.05	57.53	74.00	16.47	Peak	Vertical
8	15720.00	28.50	12.05	40.55	54.00	13.45	Average	Vertical

TEST REPORT

IEEE 802.11n-HT20_Channel 52

No.	Frequency (MHz)	Reading (dBuV/m)	Correction factor (dB)	Result (dBuV/m)	Limit (dBuV/m)	Margin (dB)	Detector	Antenna Polaxis
1	10520.00	40.31	11.42	51.73	74.00	22.27	Peak	Horizontal
2	10520.00	28.04	11.42	39.46	54.00	14.54	Average	Horizontal
3	15780.00	45.77	11.16	56.93	74.00	17.07	Peak	Horizontal
4	15780.00	26.41	11.16	37.57	54.00	16.43	Average	Horizontal
5	10520.00	39.53	9.43	48.96	74.00	25.04	Peak	Vertical
6	10520.00	26.87	9.43	36.30	54.00	17.70	Average	Vertical
7	15780.00	41.14	12.19	53.33	74.00	20.67	Peak	Vertical
8	15780.00	26.38	12.19	38.57	54.00	15.43	Average	Vertical

IEEE 802.11n-HT20_Channel 60

No.	Frequency (MHz)	Reading (dBuV/m)	Correction factor (dB)	Result (dBuV/m)	Limit (dBuV/m)	Margin (dB)	Detector	Antenna Polaxis
1	10600.00	39.34	11.33	50.67	74.00	23.33	Peak	Horizontal
2	10600.00	28.04	11.33	39.37	54.00	14.63	Average	Horizontal
3	15900.00	41.71	11.33	53.04	74.00	20.96	Peak	Horizontal
4	15900.00	24.96	11.33	36.29	54.00	17.71	Average	Horizontal
5	10600.00	38.87	9.37	48.24	74.00	25.76	Peak	Vertical
6	10600.00	26.83	9.37	36.20	54.00	17.80	Average	Vertical
7	15900.00	43.84	12.45	56.29	74.00	17.71	Peak	Vertical
8	15900.00	25.78	12.45	38.23	54.00	15.77	Average	Vertical

IEEE 802.11n-HT20_Channel 64

No.	Frequency (MHz)	Reading (dBuV/m)	Correction factor (dB)	Result (dBuV/m)	Limit (dBuV/m)	Margin (dB)	Detector	Antenna Polaxis
1	4924.00	40.07	11.29	51.36	74.00	22.64	Peak	Horizontal
2	4924.00	28.03	11.29	39.32	54.00	14.68	Average	Horizontal
3	7386.00	41.68	11.49	53.17	74.00	20.83	Peak	Horizontal
4	7386.00	25.81	11.49	37.30	54.00	16.70	Average	Horizontal
5	4924.00	39.99	9.34	49.33	74.00	24.67	Peak	Vertical
6	4924.00	26.99	9.34	36.33	54.00	17.67	Average	Vertical
7	7386.00	43.87	12.66	56.53	74.00	17.47	Peak	Vertical
8	7386.00	26.64	12.66	39.30	54.00	14.70	Average	Vertical

TEST REPORT

IEEE 802.11n-HT20_Channel 100

No.	Frequency (MHz)	Reading (dBuV/m)	Correction factor (dB)	Result (dBuV/m)	Limit (dBuV/m)	Margin (dB)	Detector	Antenna Polaxis
1	11000.00	40.65	10.30	50.95	74.00	23.05	Peak	Horizontal
2	11000.00	28.88	10.30	39.18	54.00	14.82	Average	Horizontal
3	16500.00	43.27	13.35	56.62	74.00	17.38	Peak	Horizontal
4	16500.00	26.44	13.35	39.79	54.00	14.21	Average	Horizontal
5	11000.00	40.18	8.50	48.68	74.00	25.32	Peak	Vertical
6	11000.00	28.29	8.50	36.79	54.00	17.21	Average	Vertical
7	16500.00	43.54	13.45	56.99	74.00	17.01	Peak	Vertical
8	16500.00	24.43	13.45	37.88	54.00	16.12	Average	Vertical

IEEE 802.11n-HT20_Channel 116

No.	Frequency (MHz)	Reading (dBuV/m)	Correction factor (dB)	Result (dBuV/m)	Limit (dBuV/m)	Margin (dB)	Detector	Antenna Polaxis
1	11160.00	40.69	9.97	50.66	74.00	23.34	Peak	Horizontal
2	11160.00	28.20	9.97	38.17	54.00	15.83	Average	Horizontal
3	16740.00	41.98	13.24	55.22	74.00	18.78	Peak	Horizontal
4	16740.00	27.63	13.24	40.87	54.00	13.13	Average	Horizontal
5	11160.00	39.21	8.27	47.48	74.00	26.52	Peak	Vertical
6	11160.00	27.48	8.27	35.75	54.00	18.25	Average	Vertical
7	16740.00	38.32	13.01	51.33	74.00	22.67	Peak	Vertical
8	16740.00	25.66	13.01	38.67	54.00	15.33	Average	Vertical

IEEE 802.11n-HT20_Channel 140

No.	Frequency (MHz)	Reading (dBuV/m)	Correction factor (dB)	Result (dBuV/m)	Limit (dBuV/m)	Margin (dB)	Detector	Antenna Polaxis
1	11400.00	40.59	9.86	50.45	74.00	23.55	Peak	Horizontal
2	11400.00	29.00	9.86	38.86	54.00	15.14	Average	Horizontal
3	17100.00	38.29	13.42	51.71	74.00	22.29	Peak	Horizontal
4	17100.00	26.26	13.42	39.68	54.00	14.32	Average	Horizontal
5	11400.00	40.28	8.30	48.58	74.00	25.42	Peak	Vertical
6	11400.00	28.84	8.30	37.14	54.00	16.86	Average	Vertical
7	17100.00	37.19	12.76	49.95	74.00	24.05	Peak	Vertical
8	17100.00	25.23	12.76	37.99	54.00	16.01	Average	Vertical

TEST REPORT

IEEE 802.11n-HT20_Channel 149

No.	Frequency (MHz)	Reading (dBuV/m)	Correction factor (dB)	Result (dBuV/m)	Limit (dBuV/m)	Margin (dB)	Detector	Antenna Polaxis
1	11490.00	40.67	9.78	50.45	74.00	23.55	Peak	Horizontal
2	11490.00	28.75	9.78	38.53	54.00	15.47	Average	Horizontal
3	17235.00	43.54	13.98	57.52	74.00	16.48	Peak	Horizontal
4	17235.00	25.63	13.98	39.61	54.00	14.39	Average	Horizontal
5	11490.00	40.18	8.27	48.45	74.00	25.55	Peak	Vertical
6	11490.00	28.74	8.27	37.01	54.00	16.99	Average	Vertical
7	17235.00	38.26	13.24	51.50	74.00	22.50	Peak	Vertical
8	17235.00	24.35	13.24	37.59	54.00	16.41	Average	Vertical

IEEE 802.11n-HT20_Channel 157

No.	Frequency (MHz)	Reading (dBuV/m)	Correction factor (dB)	Result (dBuV/m)	Limit (dBuV/m)	Margin (dB)	Detector	Antenna Polaxis
1	11570.00	40.56	9.86	50.42	74.00	23.58	Peak	Horizontal
2	11570.00	28.26	9.86	38.12	54.00	15.88	Average	Horizontal
3	17355.00	44.71	14.49	59.20	74.00	14.80	Peak	Horizontal
4	17355.00	27.61	14.49	42.10	54.00	11.90	Average	Horizontal
5	11570.00	40.28	8.47	48.75	74.00	25.25	Peak	Vertical
6	11570.00	27.89	8.47	36.36	54.00	17.64	Average	Vertical
7	17355.00	39.40	13.68	53.08	74.00	20.92	Peak	Vertical
8	17355.00	27.34	13.68	41.02	54.00	12.98	Average	Vertical

IEEE 802.11n-HT20_Channel 165

No.	Frequency (MHz)	Reading (dBuV/m)	Correction factor (dB)	Result (dBuV/m)	Limit (dBuV/m)	Margin (dB)	Detector	Antenna Polaxis
1	11650.00	41.19	9.95	51.14	74.00	22.86	Peak	Horizontal
2	11650.00	28.25	9.95	38.20	54.00	15.80	Average	Horizontal
3	17475.00	45.85	14.89	60.74	74.00	13.26	Peak	Horizontal
4	17475.00	29.38	14.89	44.27	54.00	9.73	Average	Horizontal
5	11650.00	39.74	8.69	48.43	74.00	25.57	Peak	Vertical
6	11650.00	27.98	8.69	36.67	54.00	17.33	Average	Vertical
7	17475.00	41.60	14.00	55.60	74.00	18.40	Peak	Vertical
8	17475.00	25.75	14.00	39.75	54.00	14.25	Average	Vertical

TEST REPORT

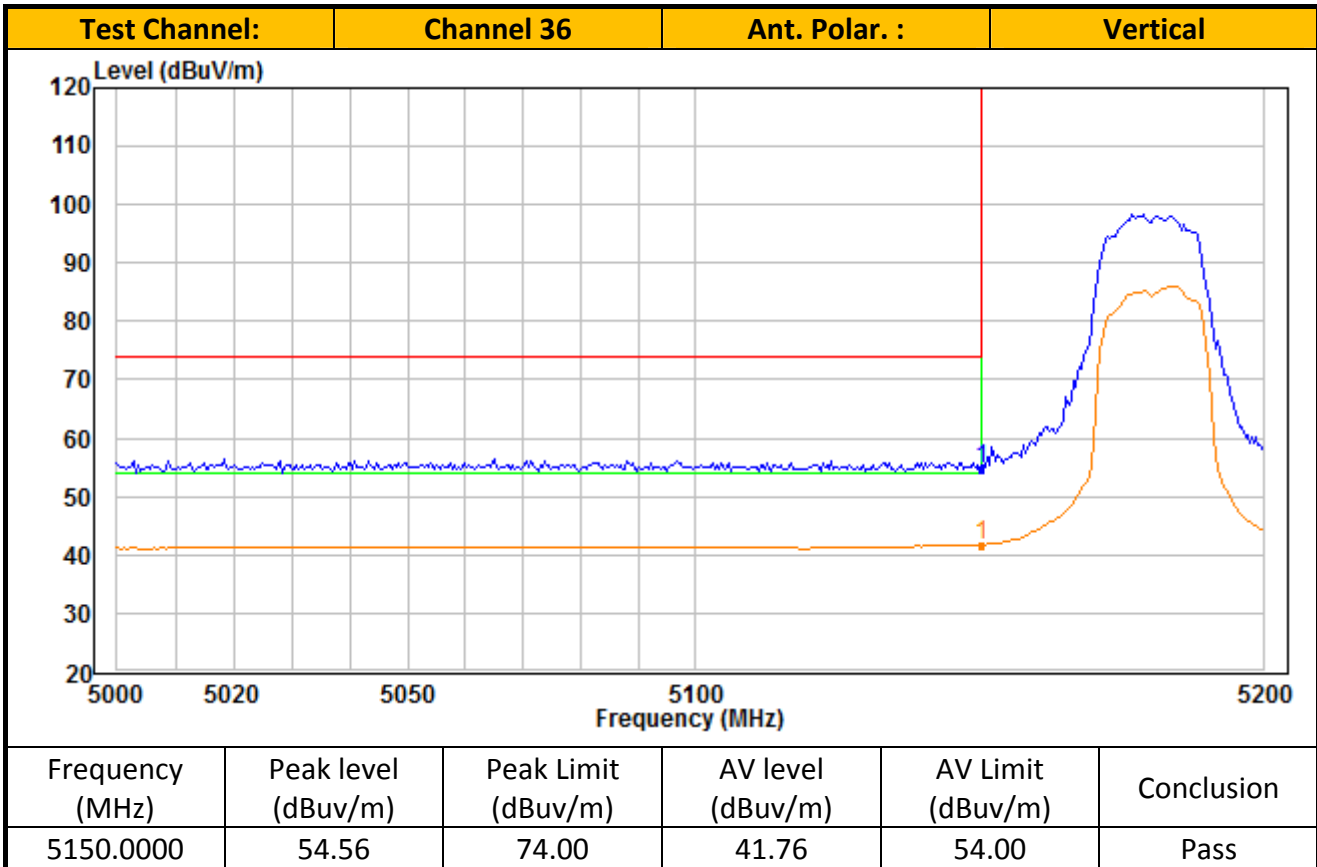
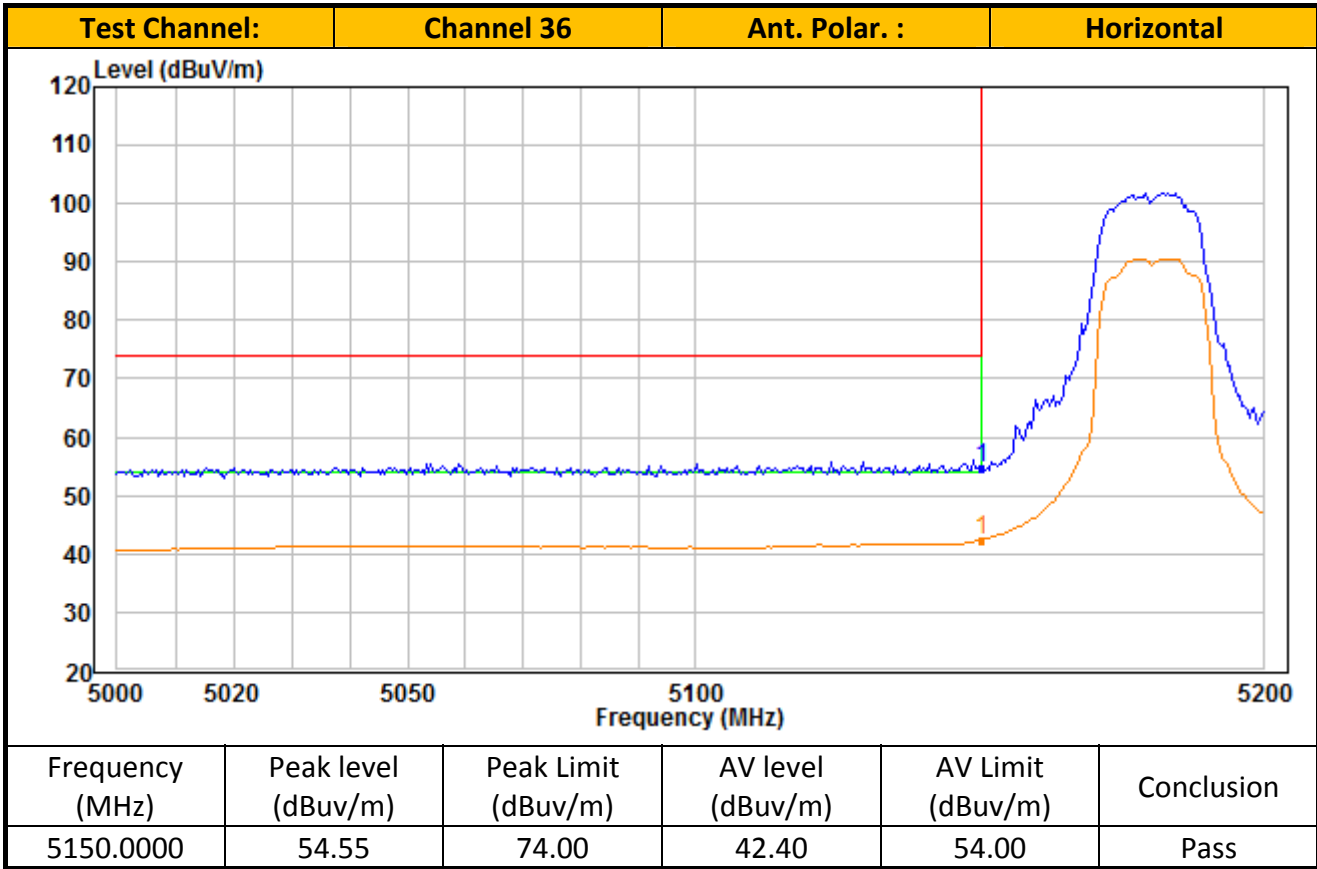

TEST REPORT

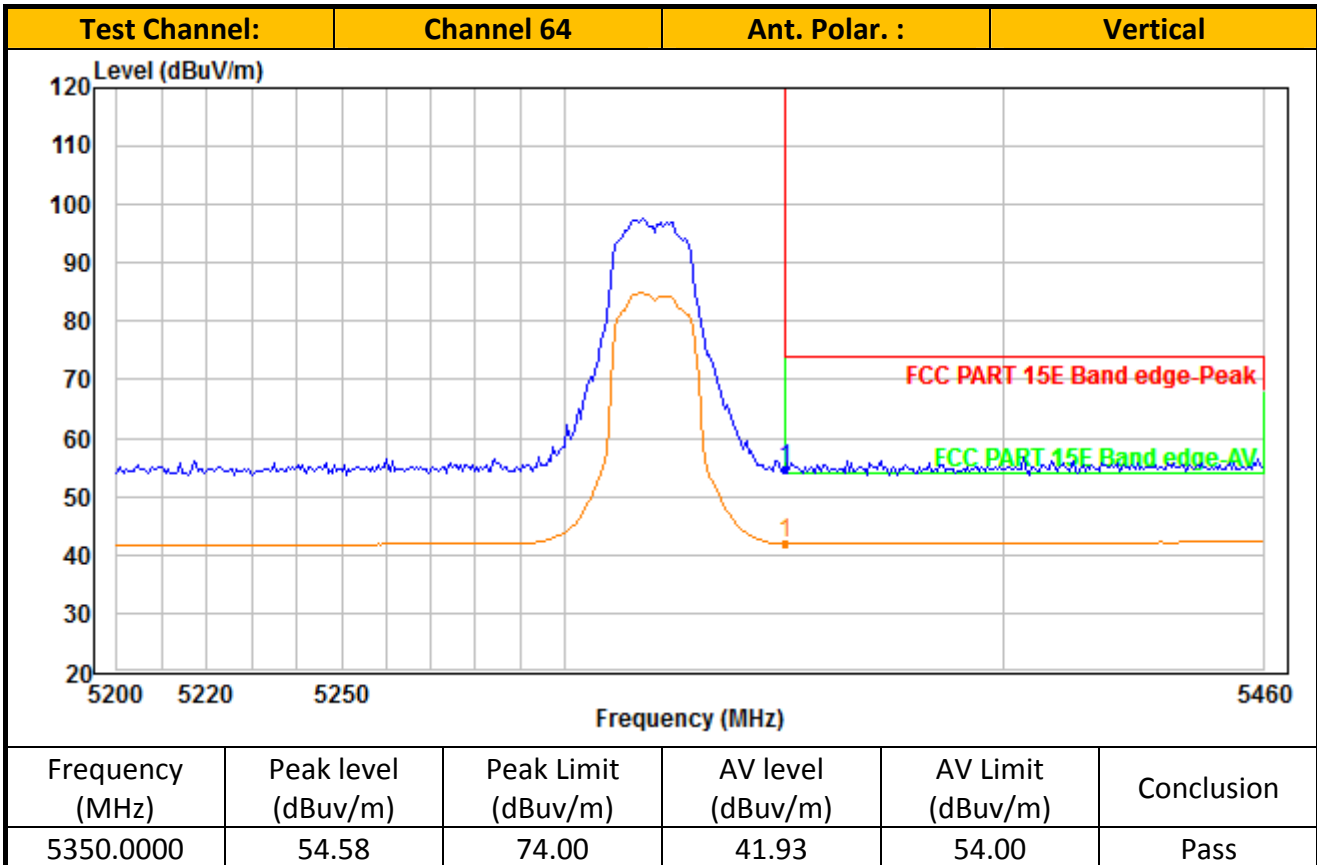
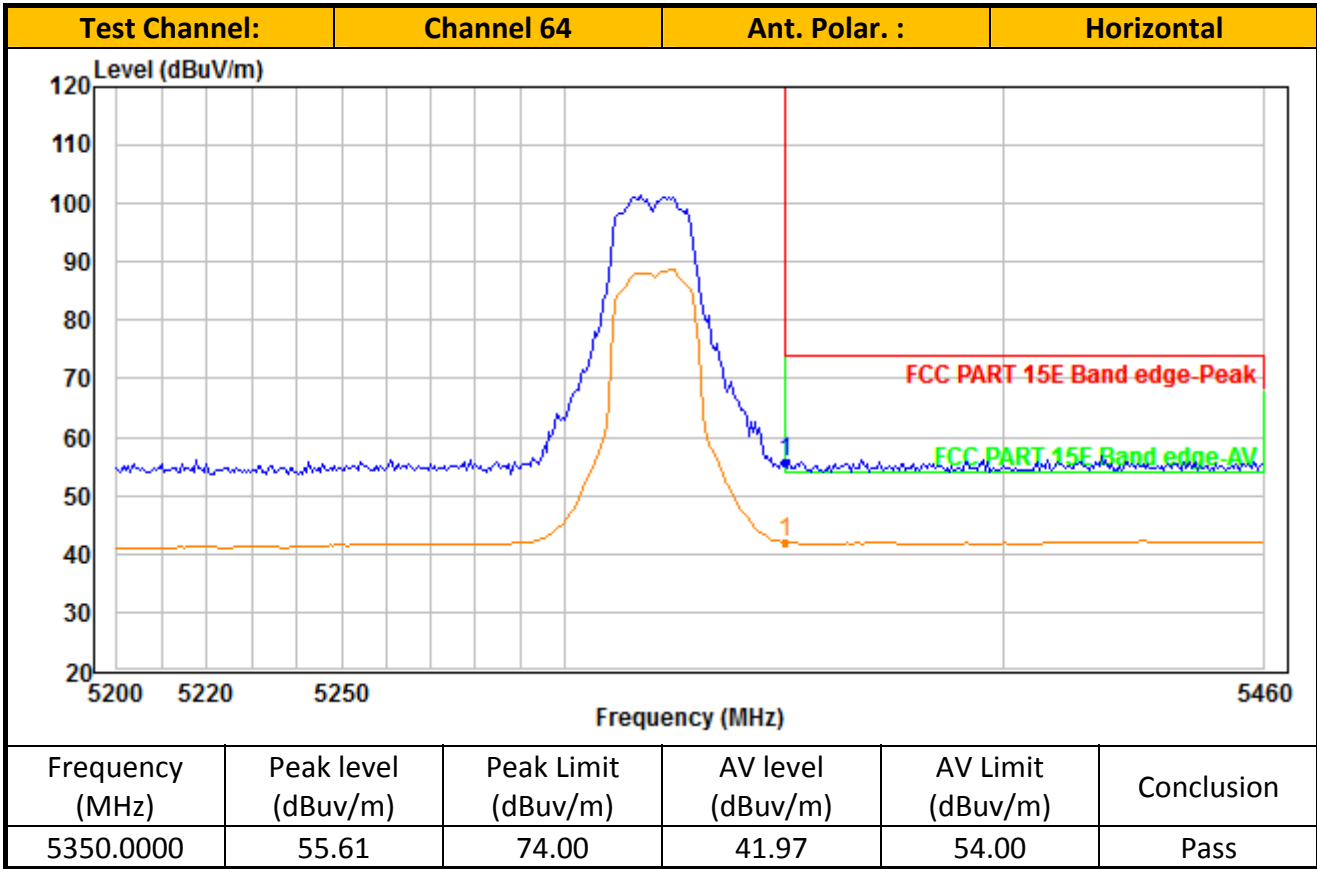

TEST REPORT

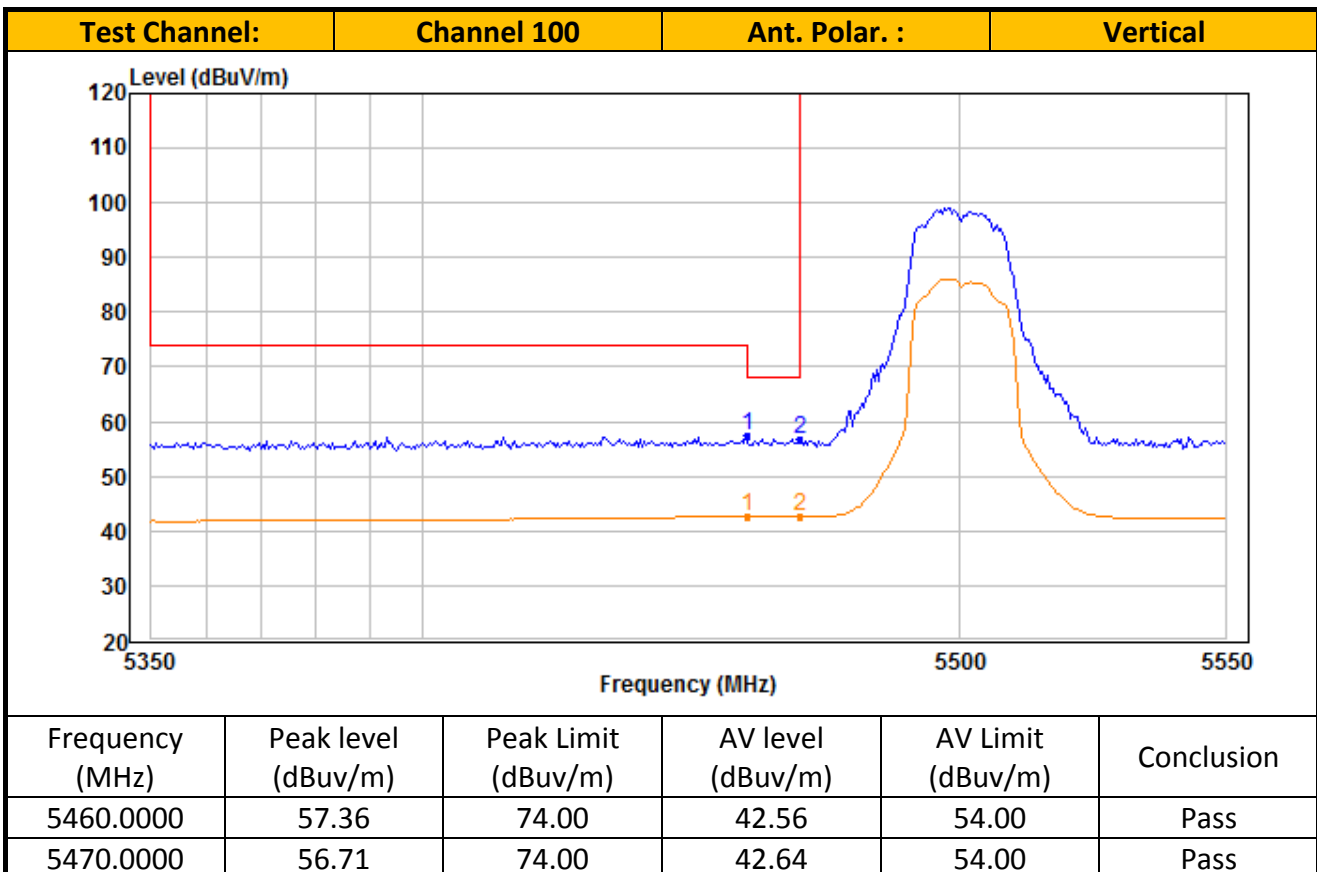
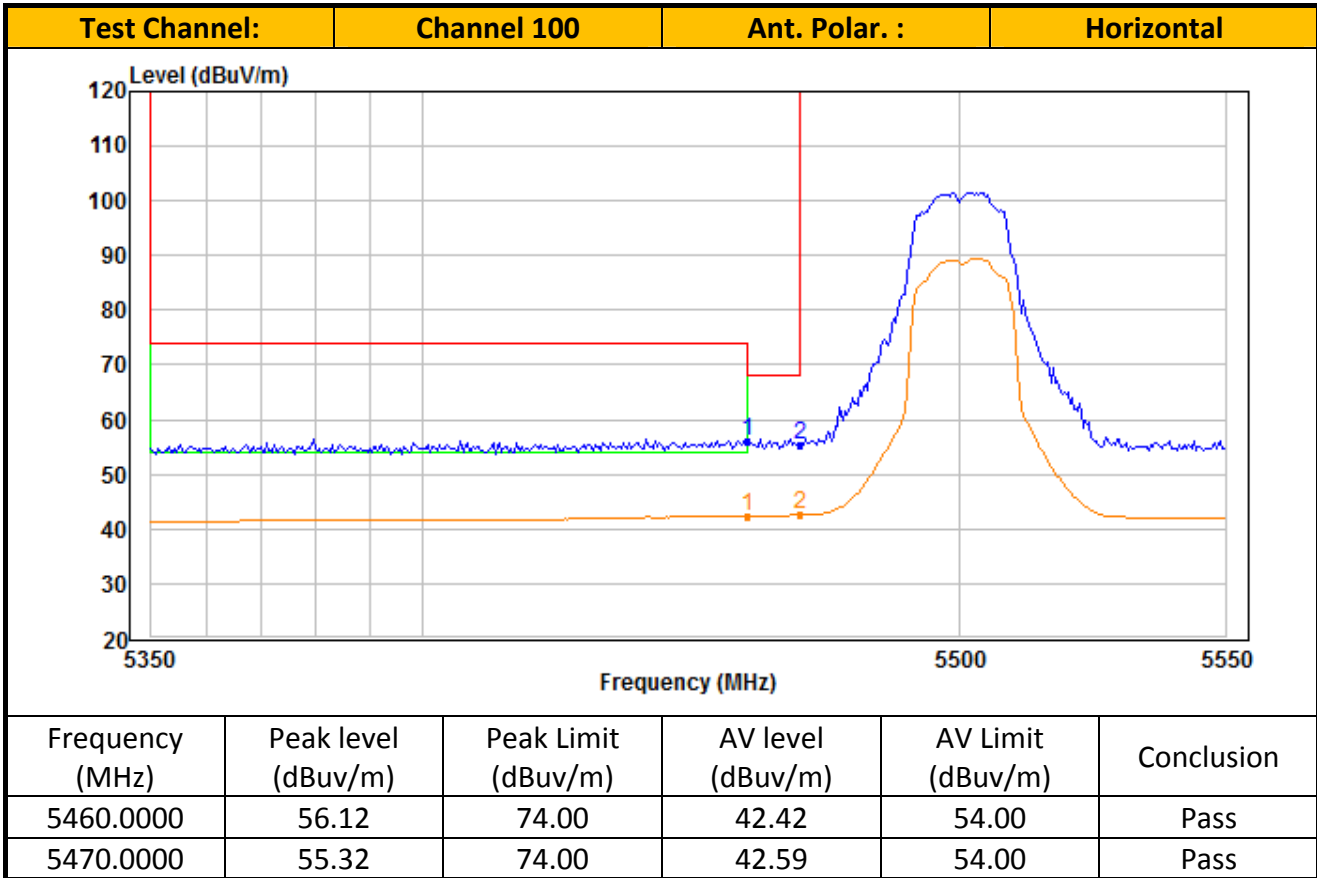

TEST REPORT

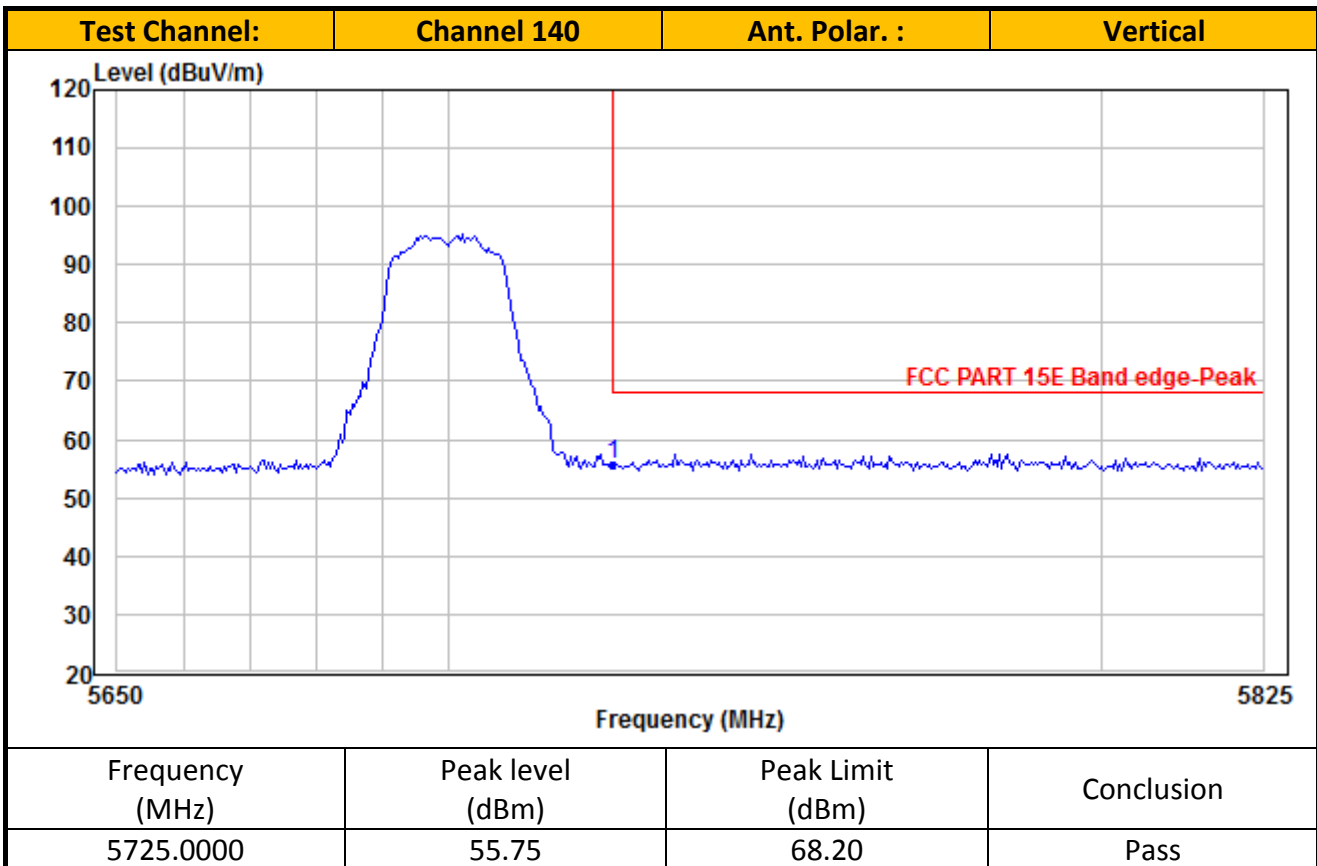
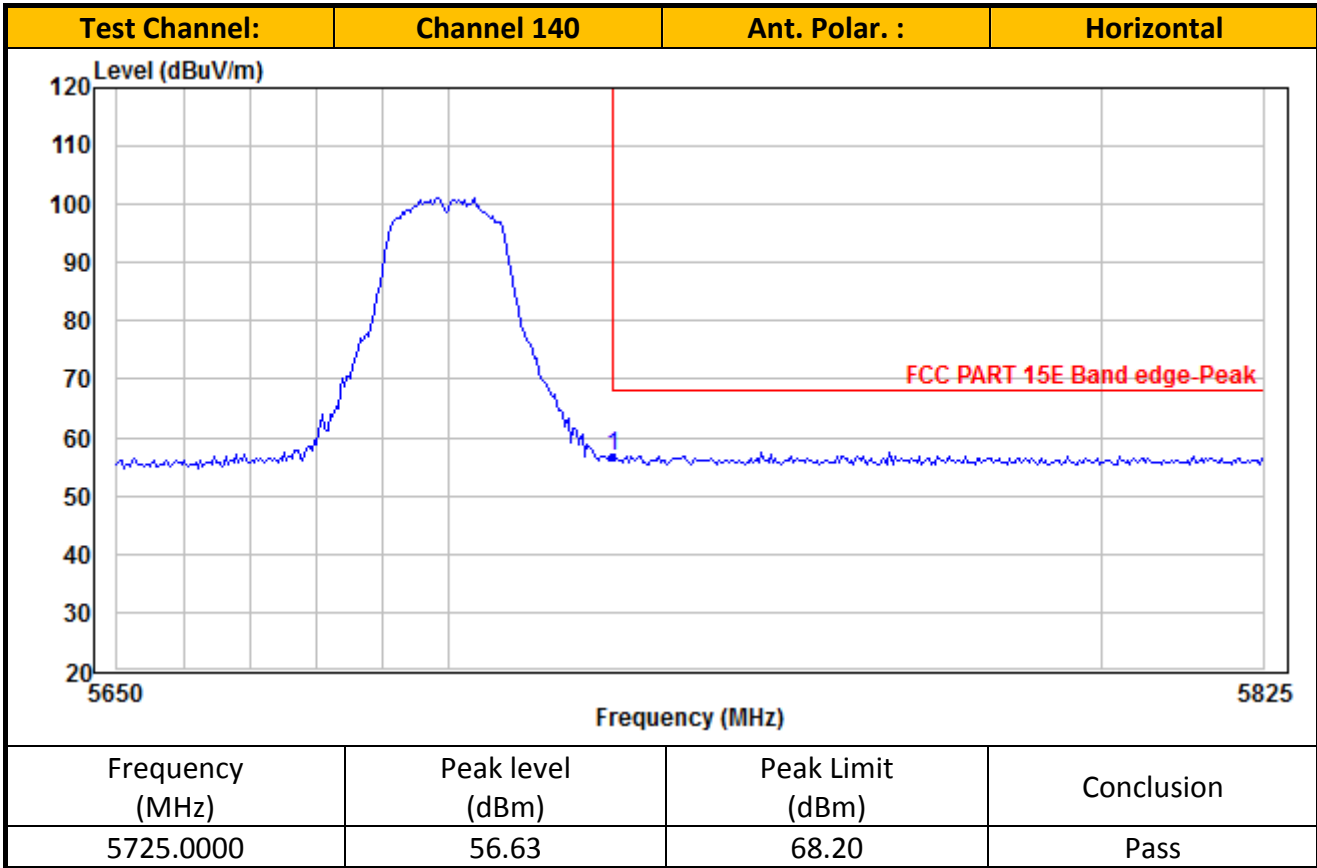

TEST REPORT

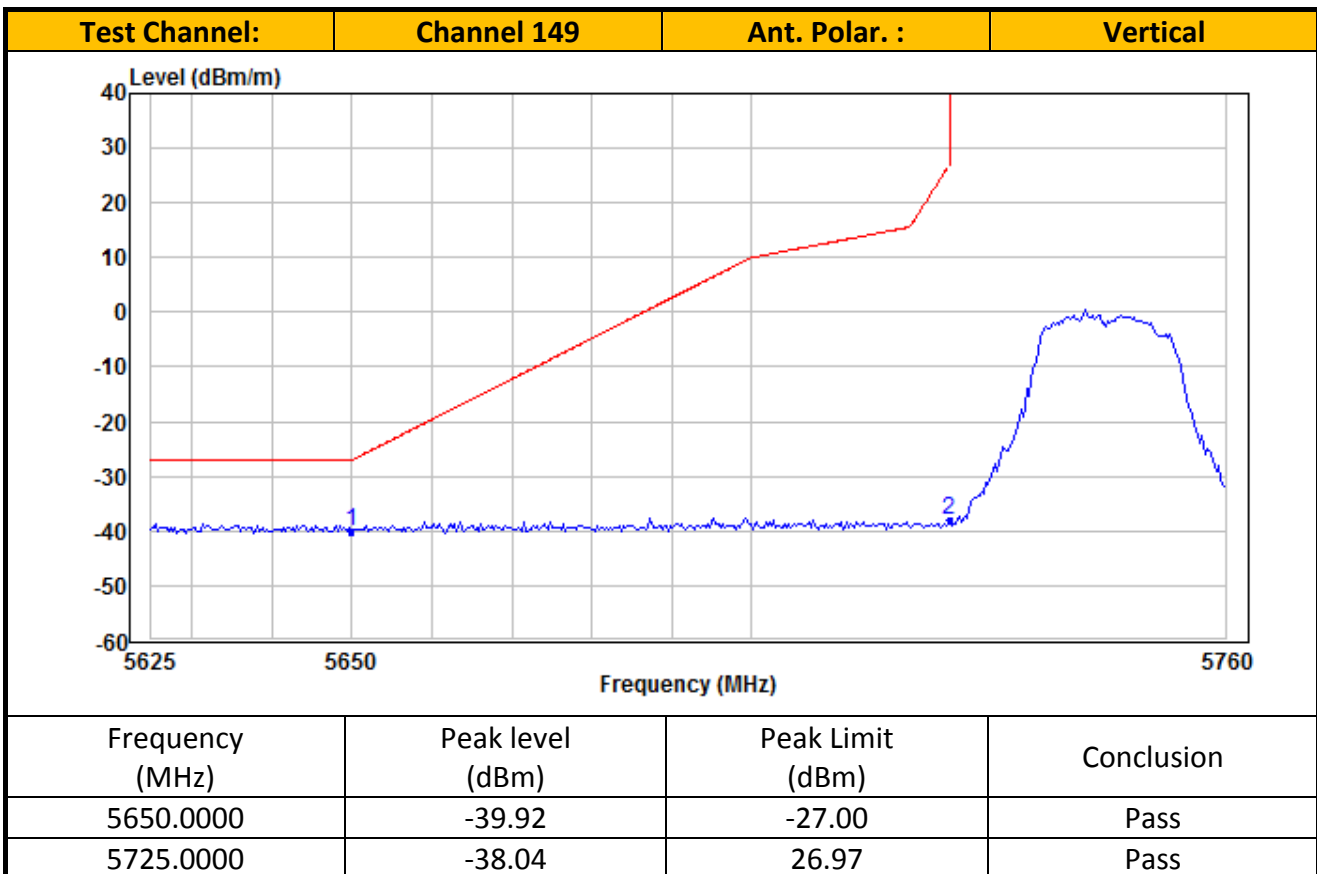
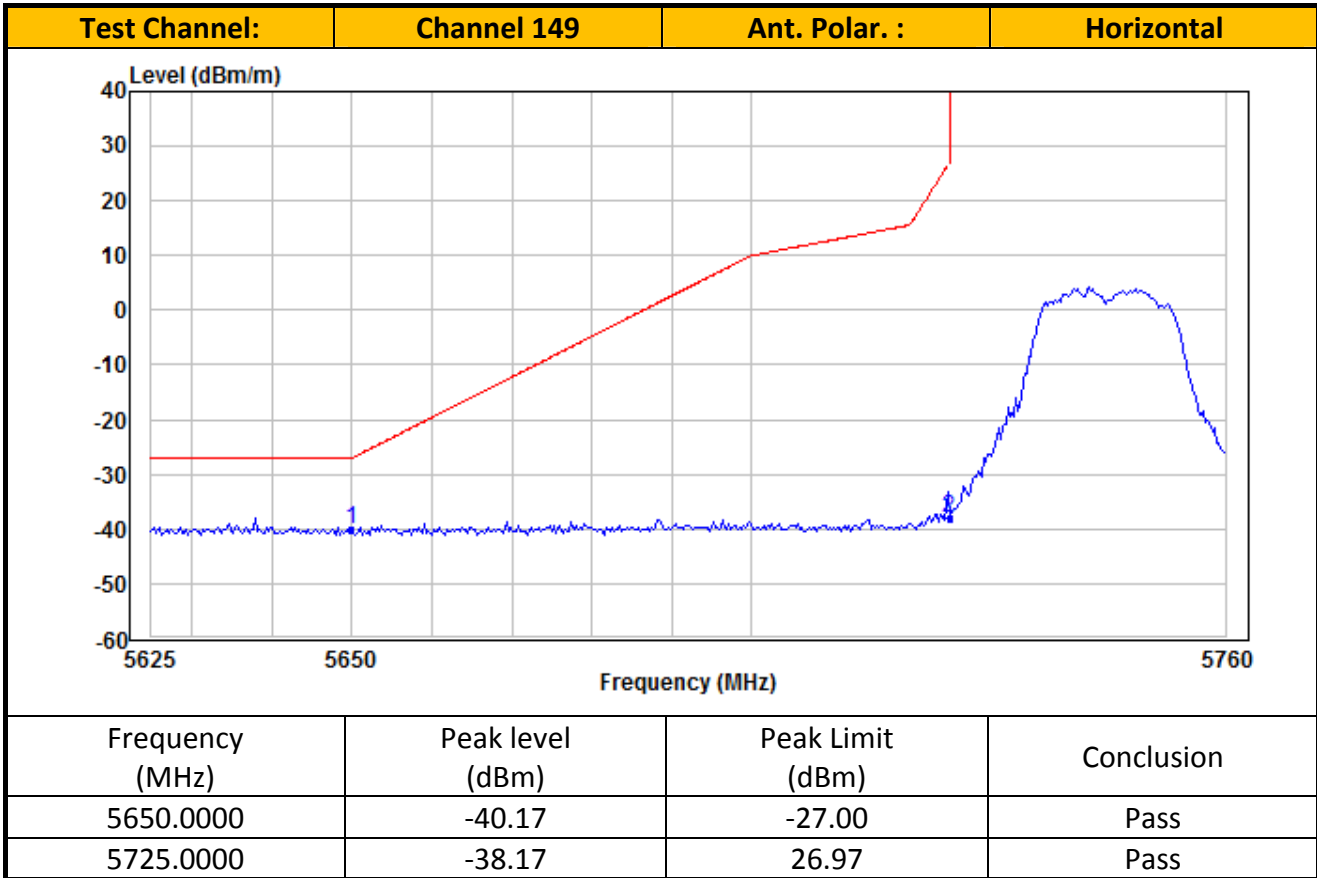

TEST REPORT

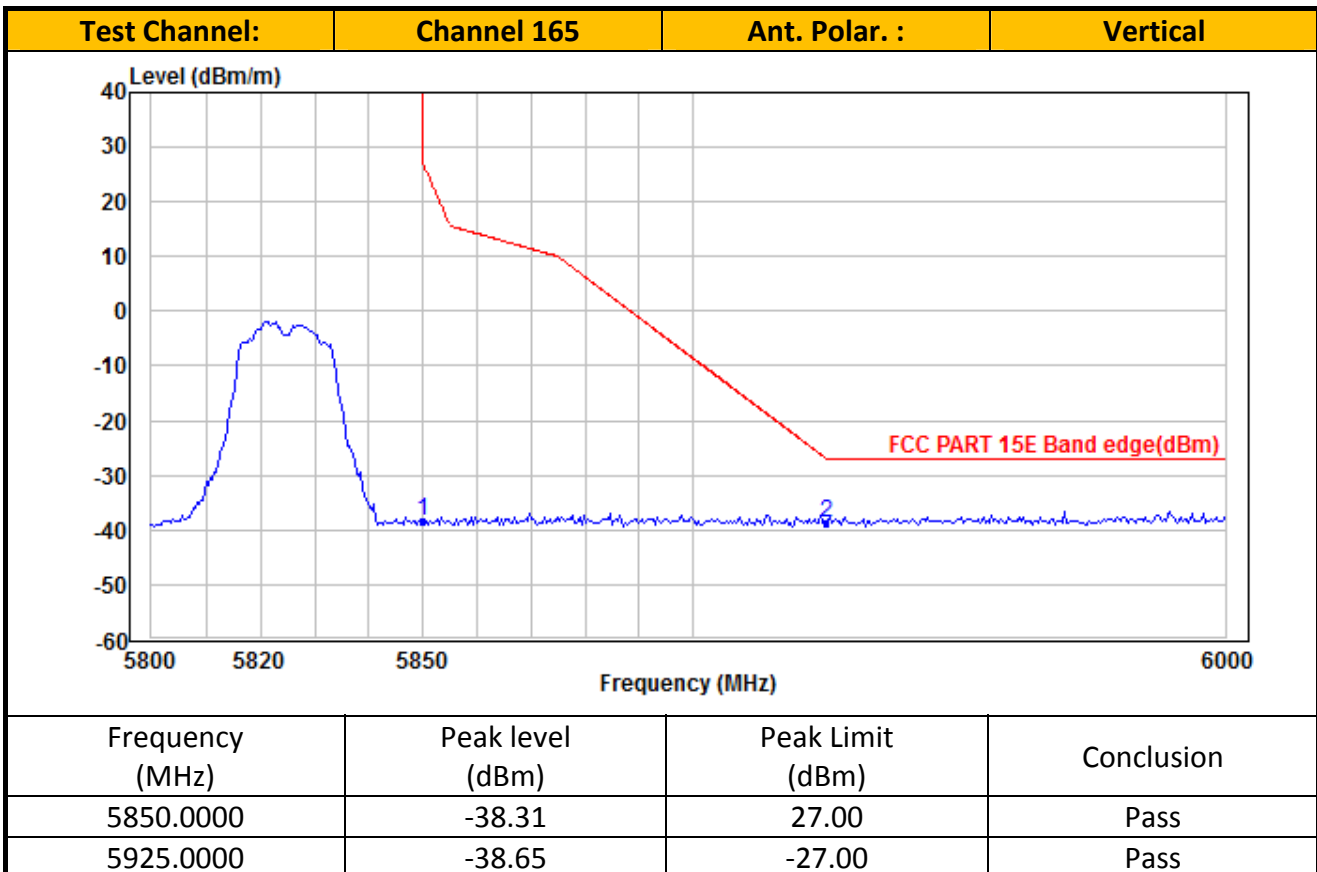
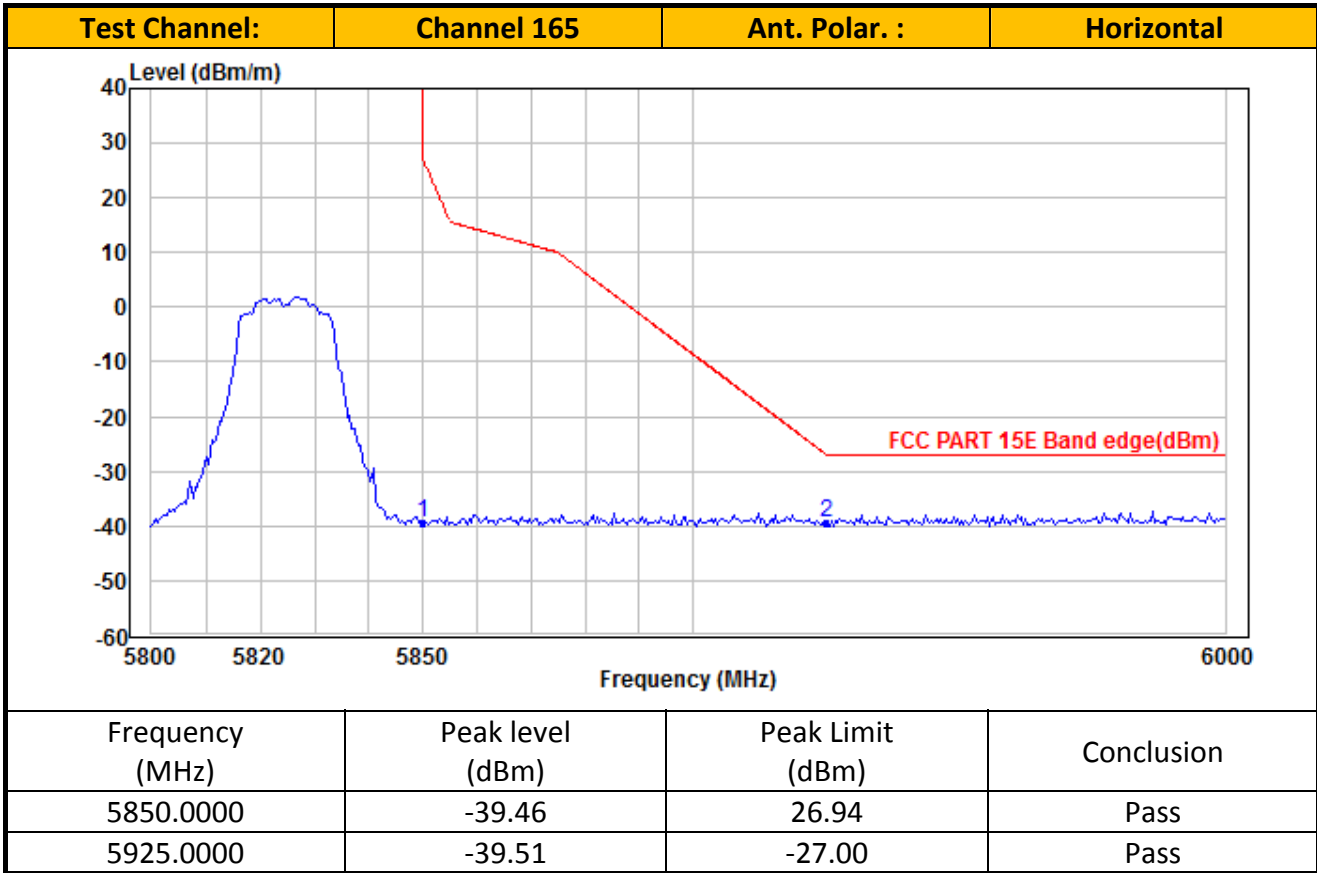

TEST REPORT

Ant. 2_ IEEE 802.11N (20MHz) (MCS0)

Radiated Emission Test Data (Above 1GHz):

IEEE 802.11n-HT20_Channel 36

No.	Frequency (MHz)	Reading (dBuV/m)	Correction factor (dB)	Result (dBuV/m)	Limit (dBuV/m)	Margin (dB)	Detector	Antenna Polaxis
1	10360.00	43.50	11.11	54.61	74.00	19.39	Peak	Horizontal
2	10360.00	30.02	11.11	41.13	54.00	12.87	Average	Horizontal
3	15540.00	49.56	10.76	60.32	74.00	13.68	Peak	Horizontal
4	15540.00	30.87	10.76	41.63	54.00	12.37	Average	Horizontal
5	10360.00	41.57	9.39	50.96	74.00	23.04	Peak	Vertical
6	10360.00	27.79	9.39	37.18	54.00	16.82	Average	Vertical
7	15540.00	39.47	11.59	51.06	74.00	22.94	Peak	Vertical
8	15540.00	26.83	11.59	38.42	54.00	15.58	Average	Vertical

IEEE 802.11n-HT20_Channel 44

No.	Frequency (MHz)	Reading (dBuV/m)	Correction factor (dB)	Result (dBuV/m)	Limit (dBuV/m)	Margin (dB)	Detector	Antenna Polaxis
1	10440.00	41.51	11.31	52.82	74.00	21.18	Peak	Horizontal
2	10440.00	29.69	11.31	41.00	54.00	13.00	Average	Horizontal
3	15660.00	49.40	12.00	61.40	74.00	12.60	Peak	Horizontal
4	15660.00	30.25	12.00	42.25	54.00	11.75	Average	Horizontal
5	10440.00	40.80	9.43	50.23	74.00	23.77	Peak	Vertical
6	10440.00	28.18	9.43	37.61	54.00	16.39	Average	Vertical
7	15660.00	43.29	11.93	55.22	74.00	18.78	Peak	Vertical
8	15660.00	26.72	11.93	38.65	54.00	15.35	Average	Vertical

IEEE 802.11n-HT20_Channel 48

No.	Frequency (MHz)	Reading (dBuV/m)	Correction factor (dB)	Result (dBuV/m)	Limit (dBuV/m)	Margin (dB)	Detector	Antenna Polaxis
1	10480.00	41.58	11.41	52.99	74.00	21.01	Peak	Horizontal
2	10480.00	29.18	11.41	40.59	54.00	13.41	Average	Horizontal
3	15720.00	50.25	11.08	61.33	74.00	12.67	Peak	Horizontal
4	15720.00	31.40	11.08	42.48	54.00	11.52	Average	Horizontal
5	10480.00	40.18	9.45	49.63	74.00	24.37	Peak	Vertical
6	10480.00	27.04	9.45	36.49	54.00	17.51	Average	Vertical
7	15720.00	44.47	12.05	56.52	74.00	17.48	Peak	Vertical
8	15720.00	26.17	12.05	38.22	54.00	15.78	Average	Vertical

TEST REPORT

IEEE 802.11n-HT20_Channel 52

No.	Frequency (MHz)	Reading (dBuV/m)	Correction factor (dB)	Result (dBuV/m)	Limit (dBuV/m)	Margin (dB)	Detector	Antenna Polaxis
1	10520.00	42.50	11.42	53.92	74.00	20.08	Peak	Horizontal
2	10520.00	29.17	11.42	40.59	54.00	-13.41	Average	Horizontal
3	15780.00	47.26	11.16	58.42	74.00	-15.58	Peak	Horizontal
4	15780.00	28.10	11.16	39.26	54.00	-14.74	Average	Horizontal
5	10520.00	39.84	9.43	49.27	74.00	-24.73	Peak	Vertical
6	10520.00	27.12	9.43	36.55	54.00	-17.45	Average	Vertical
7	15780.00	41.83	12.19	54.02	74.00	-19.98	Peak	Vertical
8	15780.00	26.59	12.19	38.78	54.00	-15.22	Average	Vertical

IEEE 802.11n-HT20_Channel 60

No.	Frequency (MHz)	Reading (dBuV/m)	Correction factor (dB)	Result (dBuV/m)	Limit (dBuV/m)	Margin (dB)	Detector	Antenna Polaxis
1	10600.00	41.30	11.33	52.63	74.00	21.37	Peak	Horizontal
2	10600.00	29.17	11.33	40.50	54.00	13.50	Average	Horizontal
3	15900.00	42.42	11.33	53.75	74.00	20.25	Peak	Horizontal
4	15900.00	26.81	11.33	38.14	54.00	15.86	Average	Horizontal
5	10600.00	40.24	9.37	49.61	74.00	24.39	Peak	Vertical
6	10600.00	27.28	9.37	36.65	54.00	17.35	Average	Vertical
7	15900.00	38.61	12.45	51.06	74.00	22.94	Peak	Vertical
8	15900.00	26.00	12.45	38.45	54.00	15.55	Average	Vertical

IEEE 802.11n-HT20_Channel 64

No.	Frequency (MHz)	Reading (dBuV/m)	Correction factor (dB)	Result (dBuV/m)	Limit (dBuV/m)	Margin (dB)	Detector	Antenna Polaxis
1	4924.00	41.80	11.29	53.09	74.00	20.91	Peak	Horizontal
2	4924.00	29.16	11.29	40.45	54.00	13.55	Average	Horizontal
3	7386.00	44.52	11.59	56.11	74.00	17.89	Peak	Horizontal
4	7386.00	27.44	11.59	39.03	54.00	14.97	Average	Horizontal
5	4924.00	38.93	9.34	48.27	74.00	25.73	Peak	Vertical
6	4924.00	27.18	9.34	36.52	54.00	17.48	Average	Vertical
7	7386.00	39.88	12.66	52.54	74.00	21.46	Peak	Vertical
8	7386.00	26.29	12.66	38.95	54.00	15.05	Average	Vertical

TEST REPORT

IEEE 802.11n-HT20_Channel 100

No.	Frequency (MHz)	Reading (dBuV/m)	Correction factor (dB)	Result (dBuV/m)	Limit (dBuV/m)	Margin (dB)	Detector	Antenna Polaxis
1	11000.00	42.13	10.30	52.43	74.00	21.57	Peak	Horizontal
2	11000.00	29.58	10.30	39.88	54.00	14.12	Average	Horizontal
3	16500.00	43.57	13.35	56.92	74.00	17.08	Peak	Horizontal
4	16500.00	28.65	13.35	42.00	54.00	12.00	Average	Horizontal
5	11000.00	41.37	8.50	49.87	74.00	24.13	Peak	Vertical
6	11000.00	28.83	8.50	37.33	54.00	16.67	Average	Vertical
7	16500.00	36.30	13.45	49.75	74.00	24.25	Peak	Vertical
8	16500.00	24.34	13.45	37.79	54.00	16.21	Average	Vertical

IEEE 802.11n-HT20_Channel 116

No.	Frequency (MHz)	Reading (dBuV/m)	Correction factor (dB)	Result (dBuV/m)	Limit (dBuV/m)	Margin (dB)	Detector	Antenna Polaxis
1	11160.00	41.73	9.97	51.70	74.00	22.30	Peak	Horizontal
2	11160.00	28.80	9.97	38.77	54.00	-15.23	Average	Horizontal
3	16740.00	44.93	13.24	58.17	74.00	-15.83	Peak	Horizontal
4	16740.00	28.65	13.24	41.89	54.00	-12.11	Average	Horizontal
5	11160.00	40.14	8.27	48.41	74.00	-25.59	Peak	Vertical
6	11160.00	27.90	8.27	36.17	54.00	-17.83	Average	Vertical
7	16740.00	39.59	13.01	52.60	74.00	-21.40	Peak	Vertical
8	16740.00	25.73	13.01	38.74	54.00	-15.26	Average	Vertical

IEEE 802.11n-HT20_Channel 140

No.	Frequency (MHz)	Reading (dBuV/m)	Correction factor (dB)	Result (dBuV/m)	Limit (dBuV/m)	Margin (dB)	Detector	Antenna Polaxis
1	11400.00	43.59	9.86	53.45	74.00	20.55	Peak	Horizontal
2	11400.00	29.79	9.86	39.65	54.00	14.35	Average	Horizontal
3	17100.00	38.29	13.42	51.71	74.00	22.29	Peak	Horizontal
4	17100.00	26.26	13.42	39.68	54.00	14.32	Average	Horizontal
5	11400.00	41.86	8.30	50.16	74.00	23.84	Peak	Vertical
6	11400.00	29.35	8.30	37.65	54.00	16.35	Average	Vertical
7	17100.00	36.29	12.76	49.05	74.00	24.95	Peak	Vertical
8	17100.00	24.23	12.76	36.99	54.00	17.01	Average	Vertical

TEST REPORT

IEEE 802.11n-HT20_Channel 149

No.	Frequency (MHz)	Reading (dBuV/m)	Correction factor (dB)	Result (dBuV/m)	Limit (dBuV/m)	Margin (dB)	Detector	Antenna Polaxis
1	11490.00	41.63	9.78	51.41	74.00	22.59	Peak	Horizontal
2	11490.00	29.21	9.78	38.99	54.00	15.01	Average	Horizontal
3	17235.00	38.85	13.98	52.83	74.00	21.17	Peak	Horizontal
4	17235.00	25.86	13.98	39.84	54.00	14.16	Average	Horizontal
5	11490.00	41.53	8.27	49.80	74.00	24.20	Peak	Vertical
6	11490.00	29.11	8.27	37.38	54.00	16.62	Average	Vertical
7	17235.00	38.06	13.24	51.30	74.00	22.70	Peak	Vertical
8	17235.00	25.29	13.24	38.53	54.00	15.47	Average	Vertical

IEEE 802.11n-HT20_Channel 157

No.	Frequency (MHz)	Reading (dBuV/m)	Correction factor (dB)	Result (dBuV/m)	Limit (dBuV/m)	Margin (dB)	Detector	Antenna Polaxis
1	11570.00	41.05	9.86	50.91	74.00	23.09	Peak	Horizontal
2	11570.00	28.64	9.86	38.50	54.00	15.50	Average	Horizontal
3	17355.00	39.35	14.49	53.84	74.00	20.16	Peak	Horizontal
4	17355.00	27.61	14.49	42.10	54.00	11.90	Average	Horizontal
5	11570.00	40.34	8.47	48.81	74.00	25.19	Peak	Vertical
6	11570.00	28.29	8.47	36.76	54.00	17.24	Average	Vertical
7	17355.00	39.73	13.68	53.41	74.00	20.59	Peak	Vertical
8	17355.00	27.21	13.68	40.89	54.00	13.11	Average	Vertical

IEEE 802.11n-HT20_Channel 165

No.	Frequency (MHz)	Reading (dBuV/m)	Correction factor (dB)	Result (dBuV/m)	Limit (dBuV/m)	Margin (dB)	Detector	Antenna Polaxis
1	11650.00	40.67	9.95	50.62	74.00	23.38	Peak	Horizontal
2	11650.00	28.64	9.95	38.59	54.00	15.41	Average	Horizontal
3	17475.00	40.04	14.89	54.93	74.00	19.07	Peak	Horizontal
4	17475.00	27.45	14.89	42.34	54.00	11.66	Average	Horizontal
5	11650.00	40.89	8.69	49.58	74.00	24.42	Peak	Vertical
6	11650.00	28.43	8.69	37.12	54.00	16.88	Average	Vertical
7	17475.00	38.07	14.00	52.07	74.00	21.93	Peak	Vertical
8	17475.00	26.54	14.00	40.54	54.00	13.46	Average	Vertical

TEST REPORT

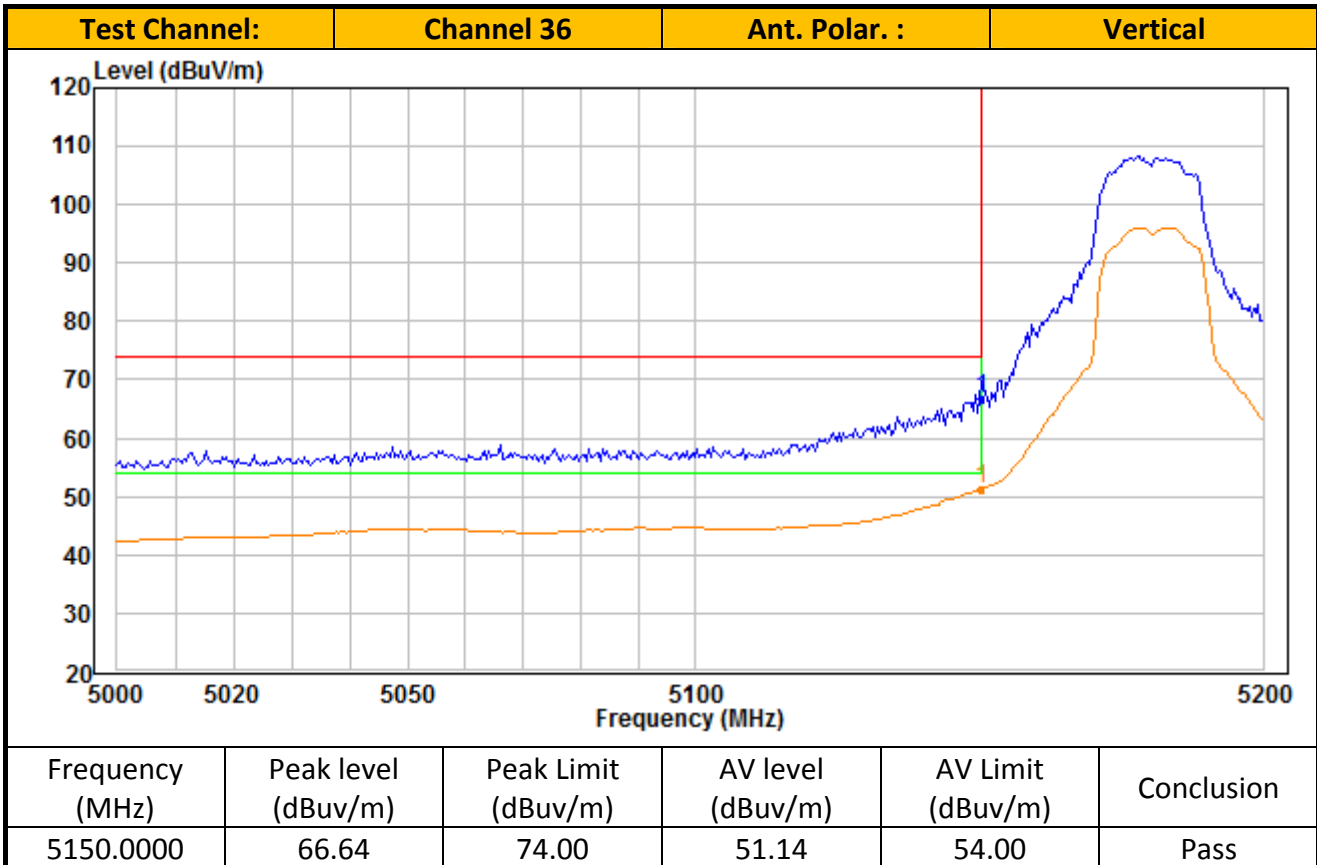
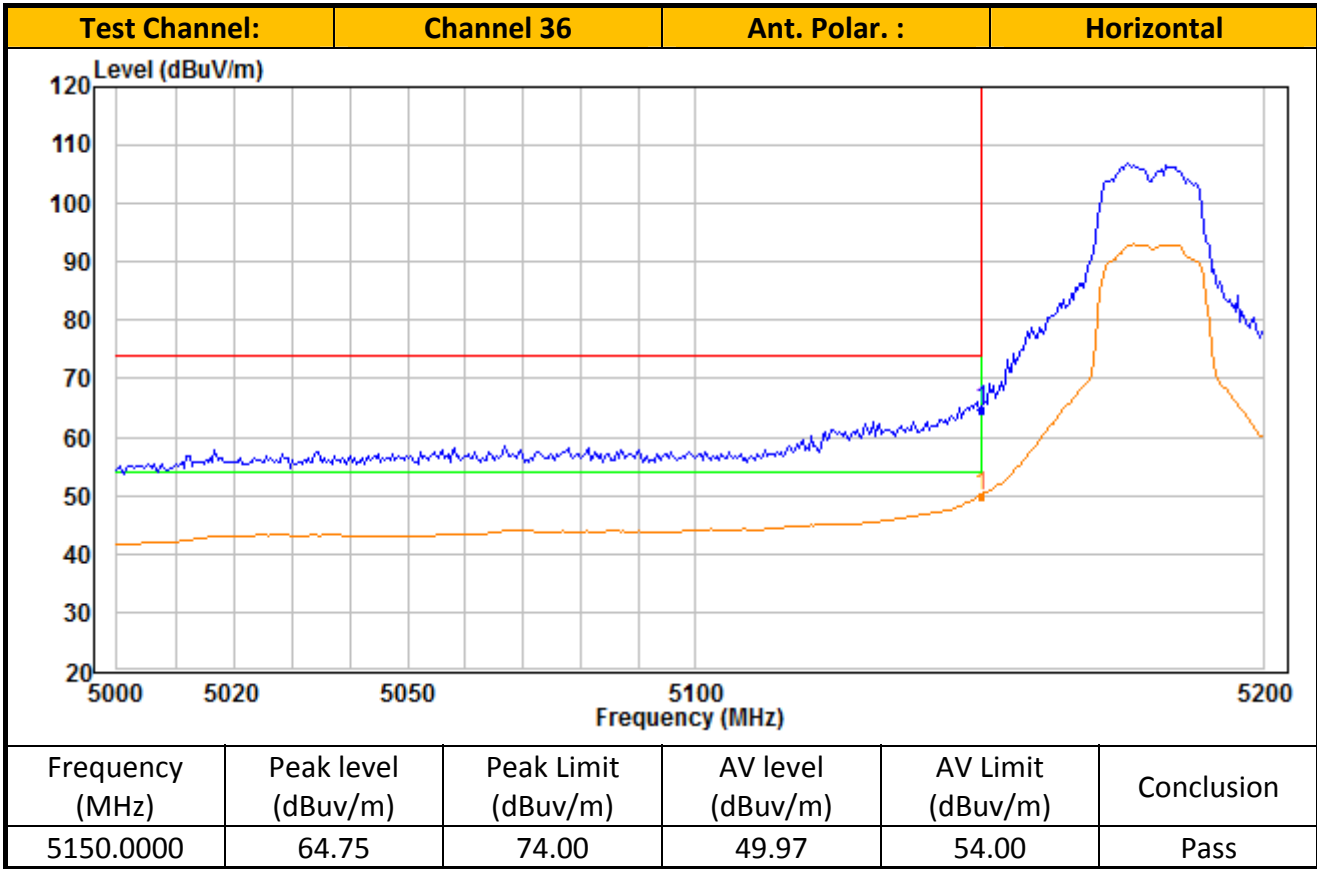

TEST REPORT

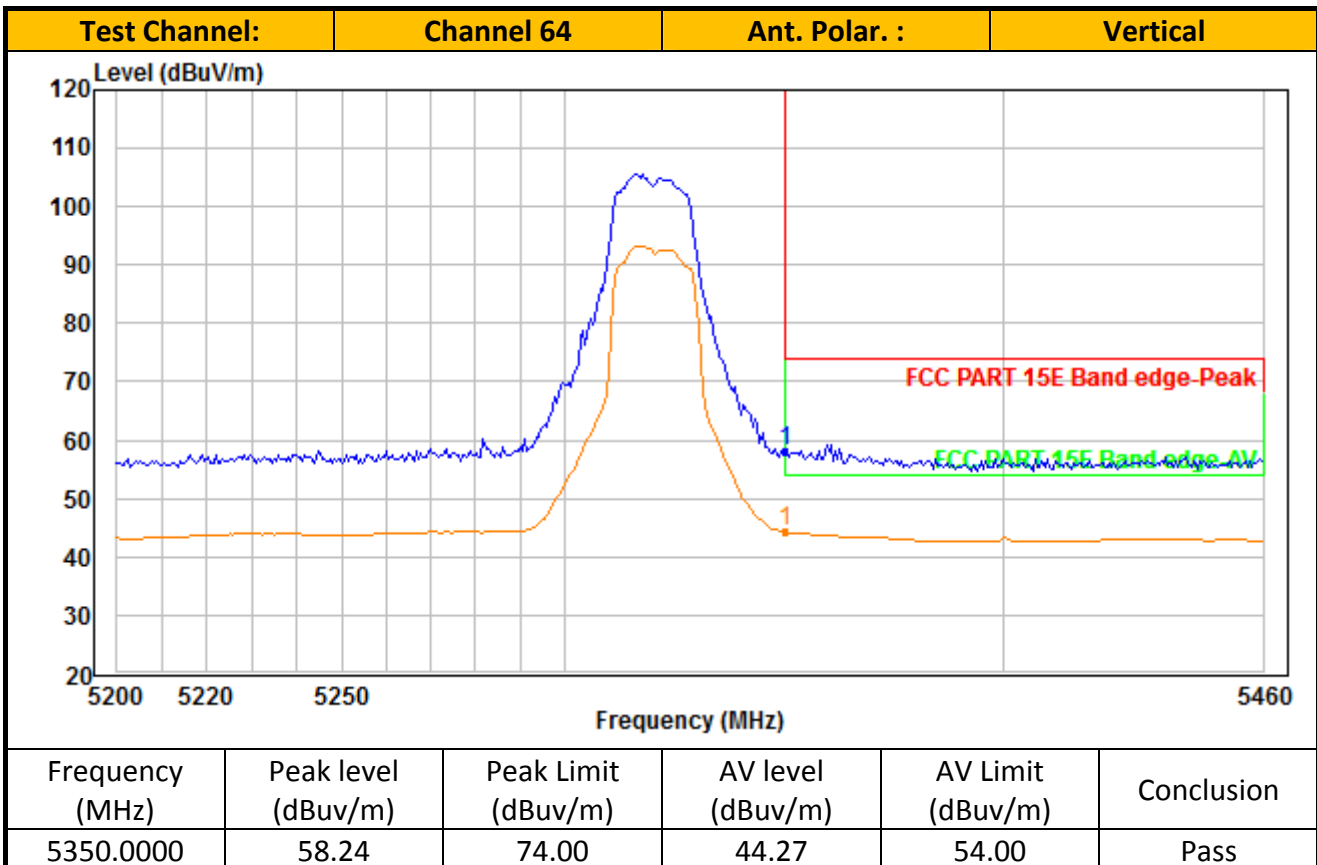
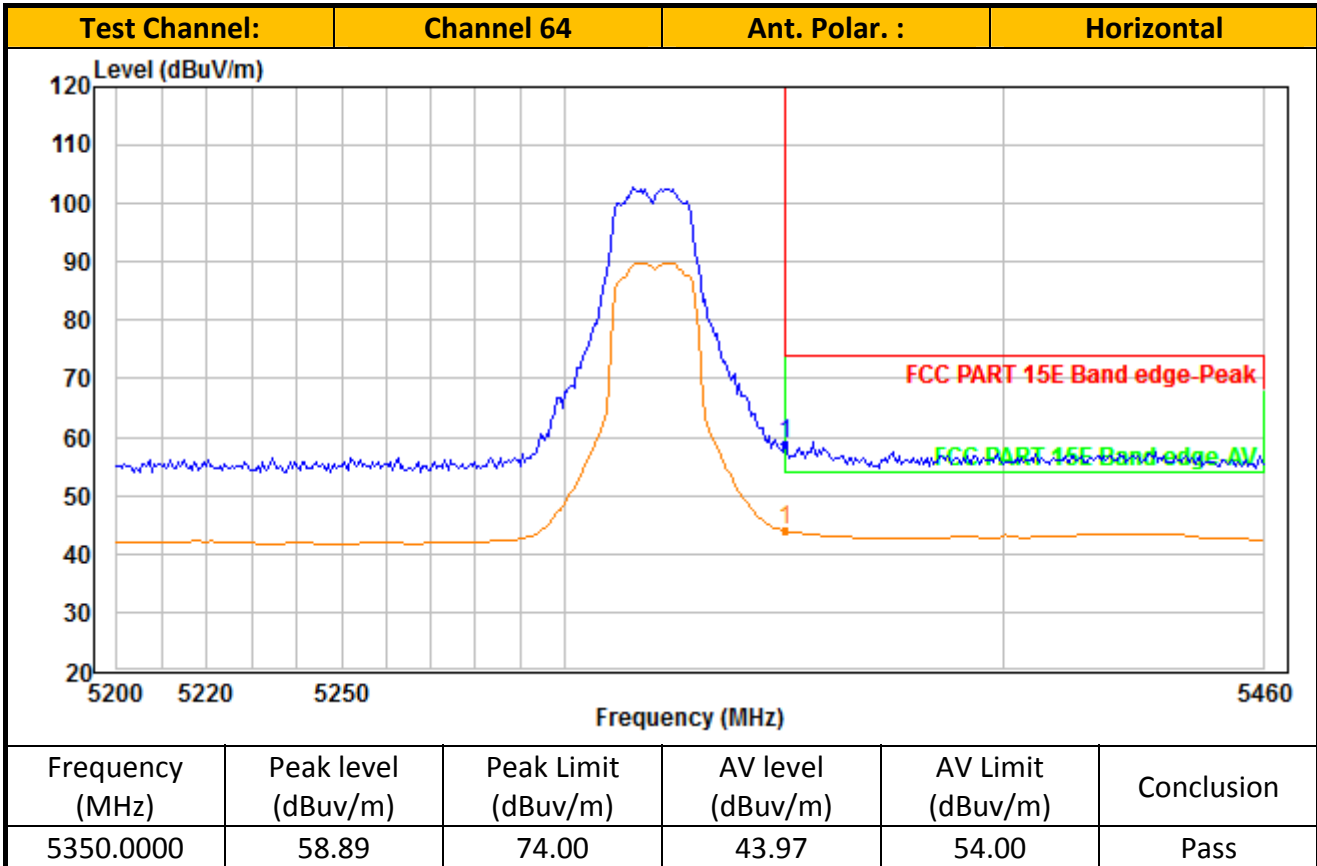

TEST REPORT

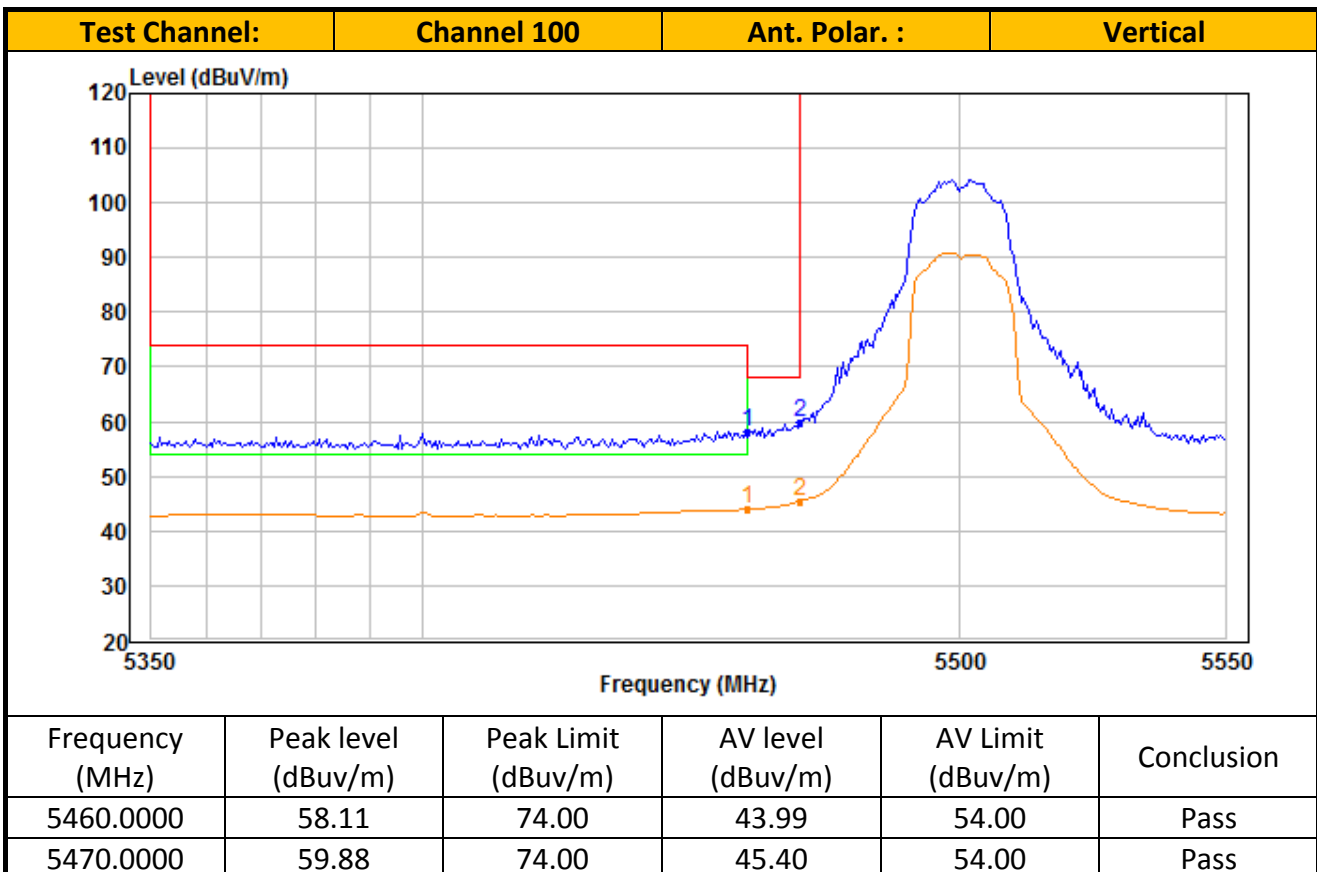
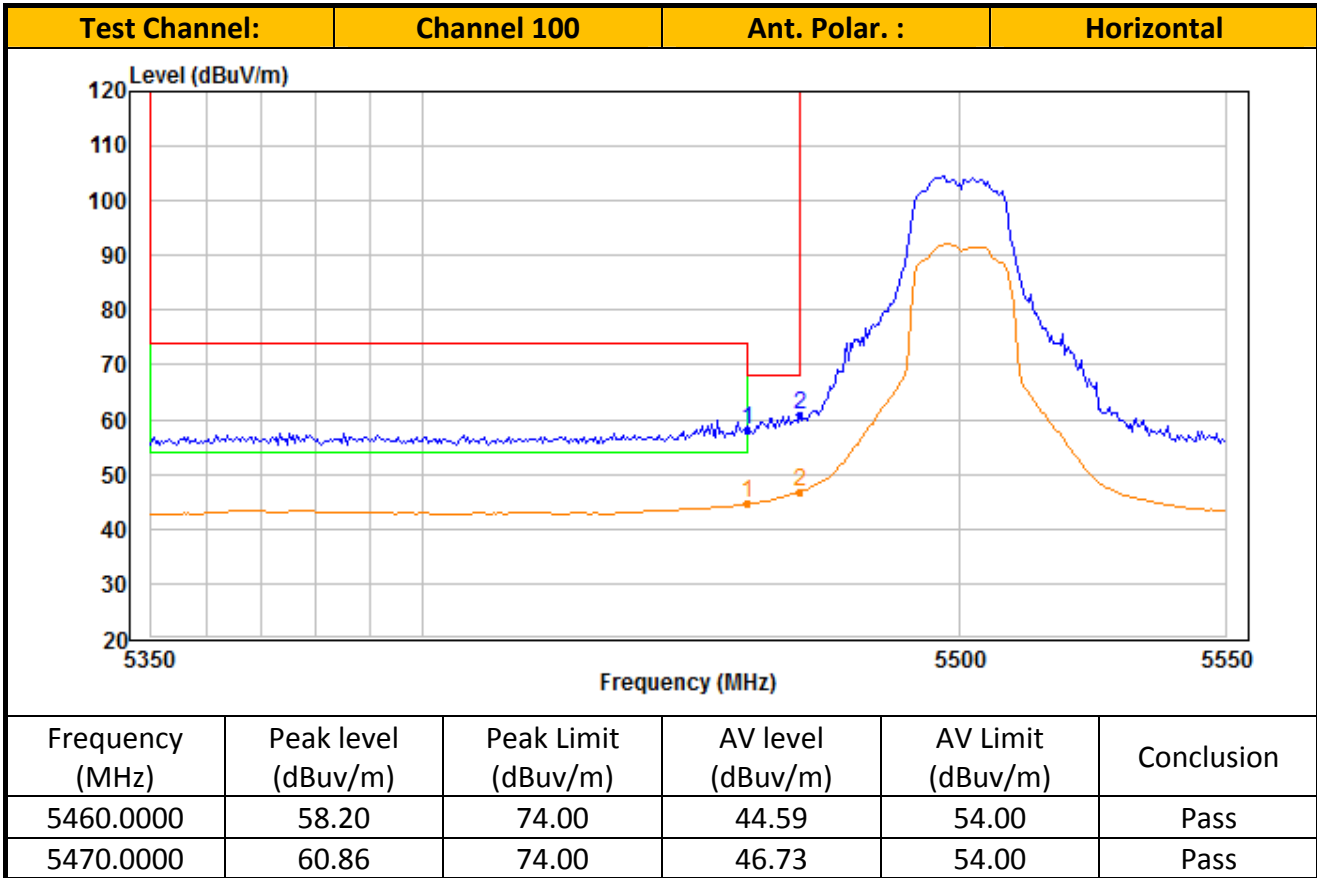

TEST REPORT

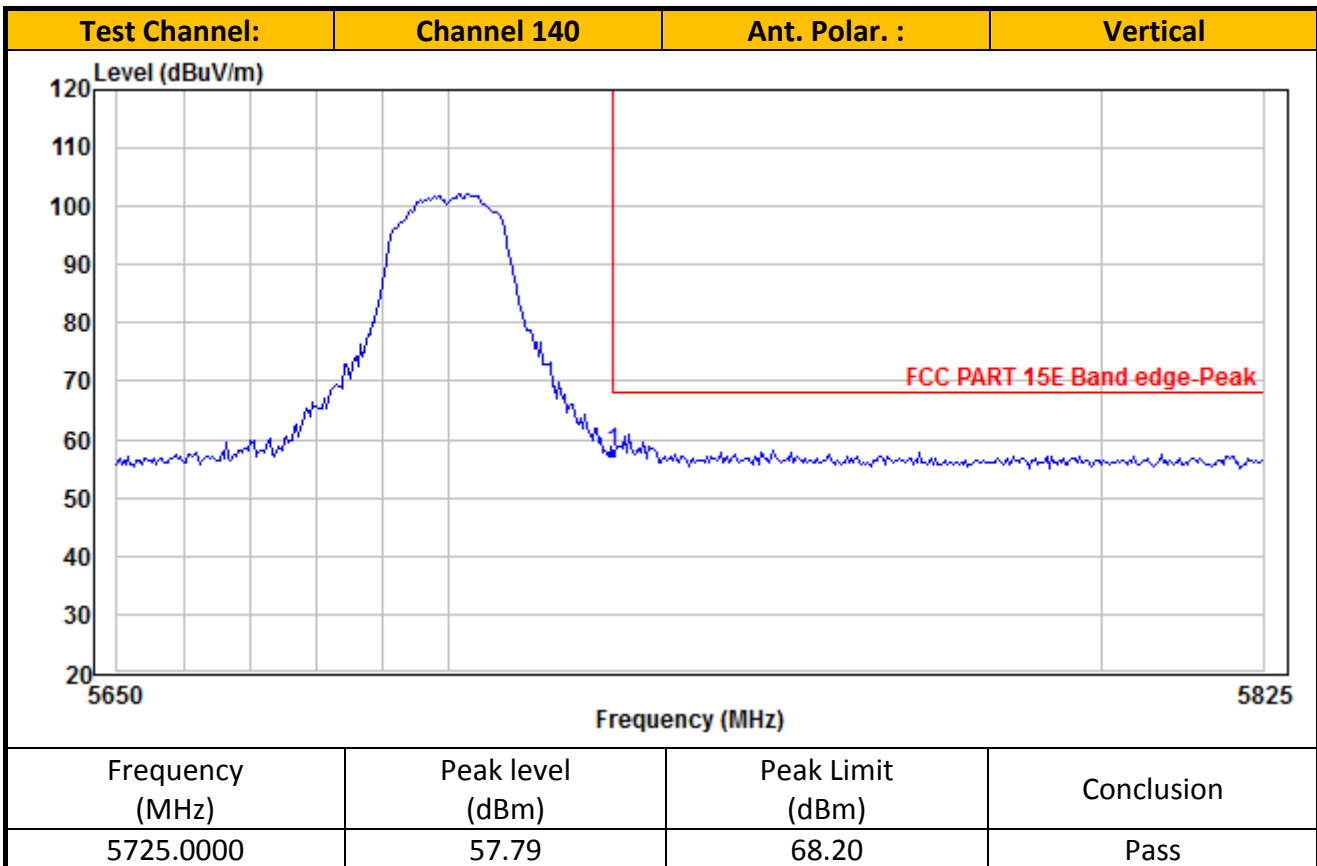
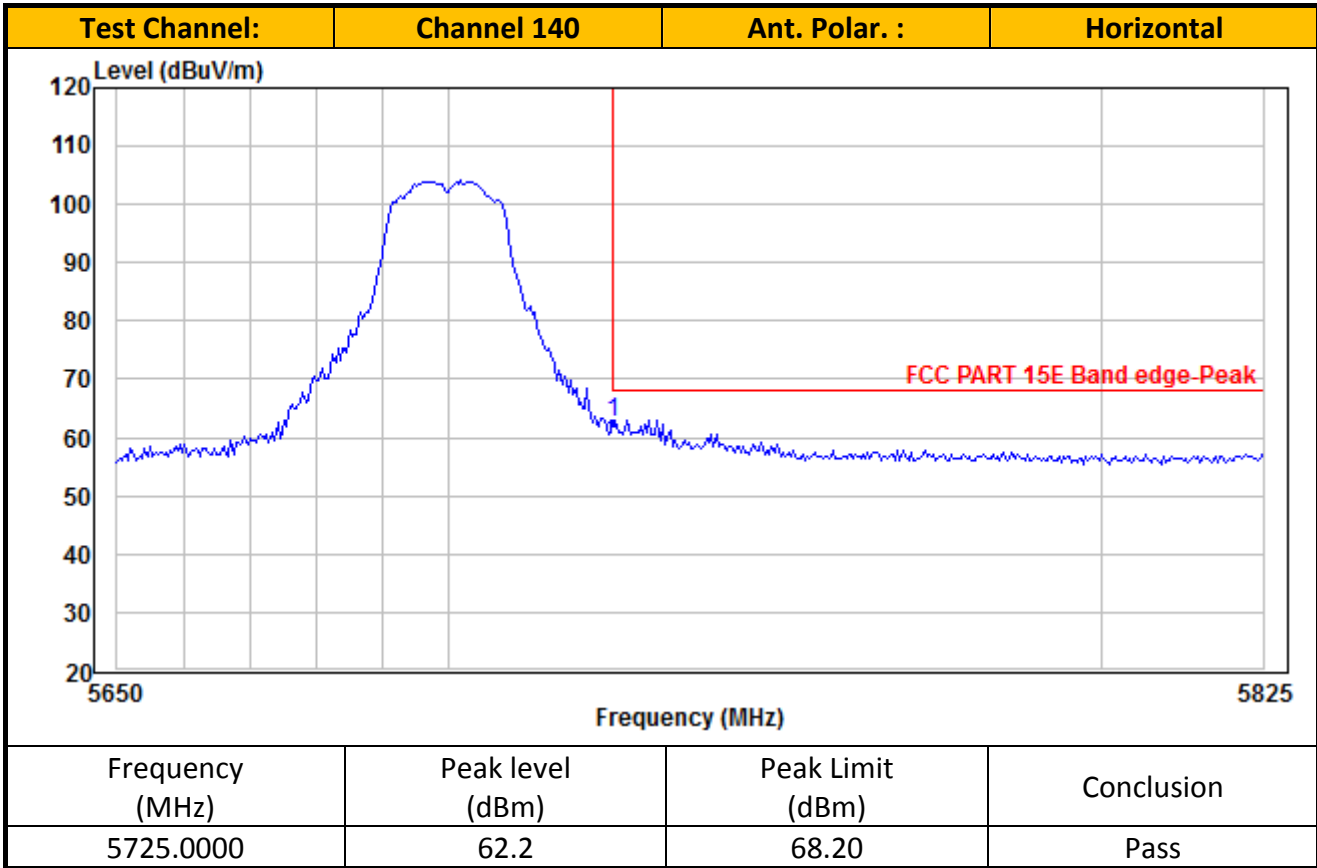

TEST REPORT

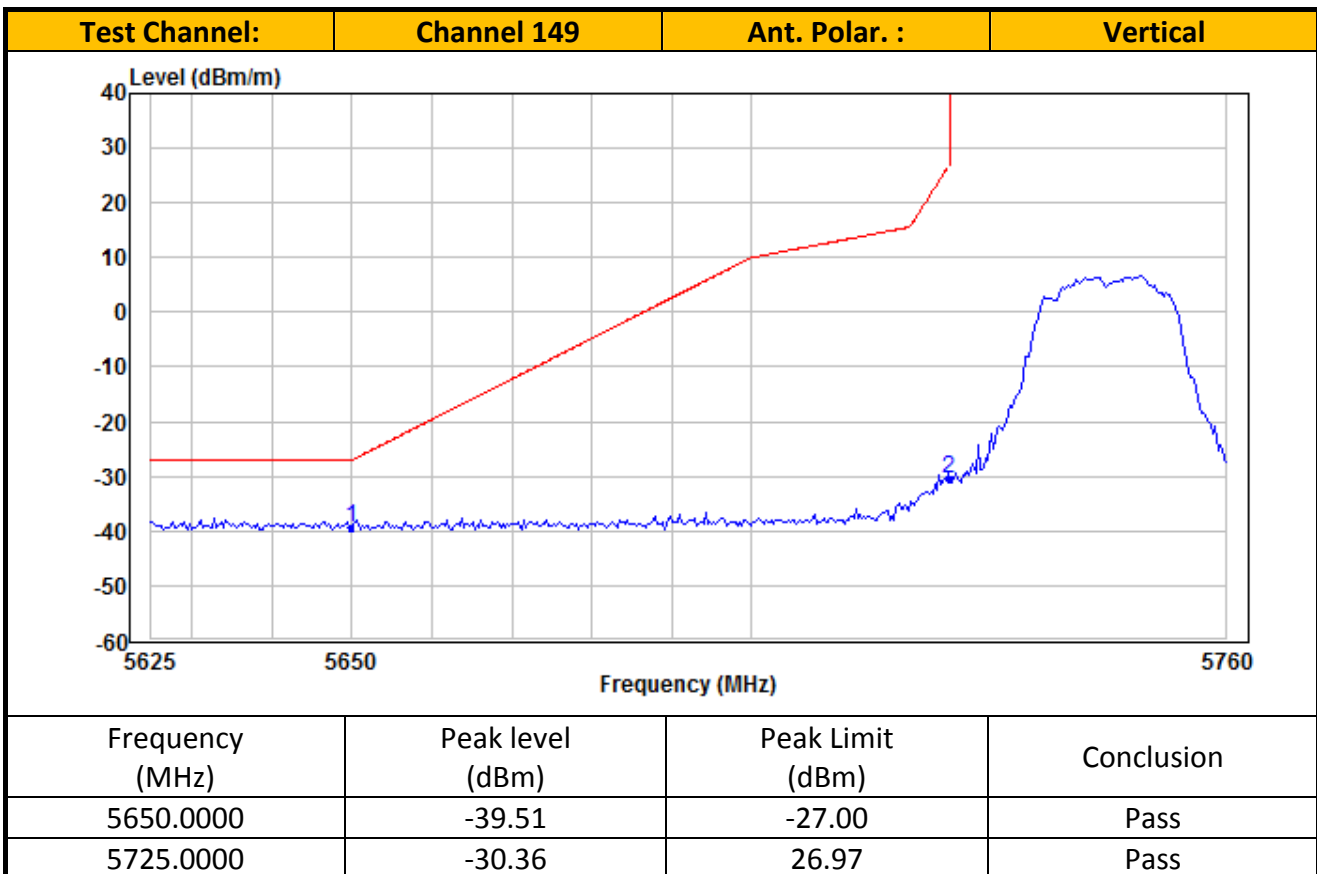
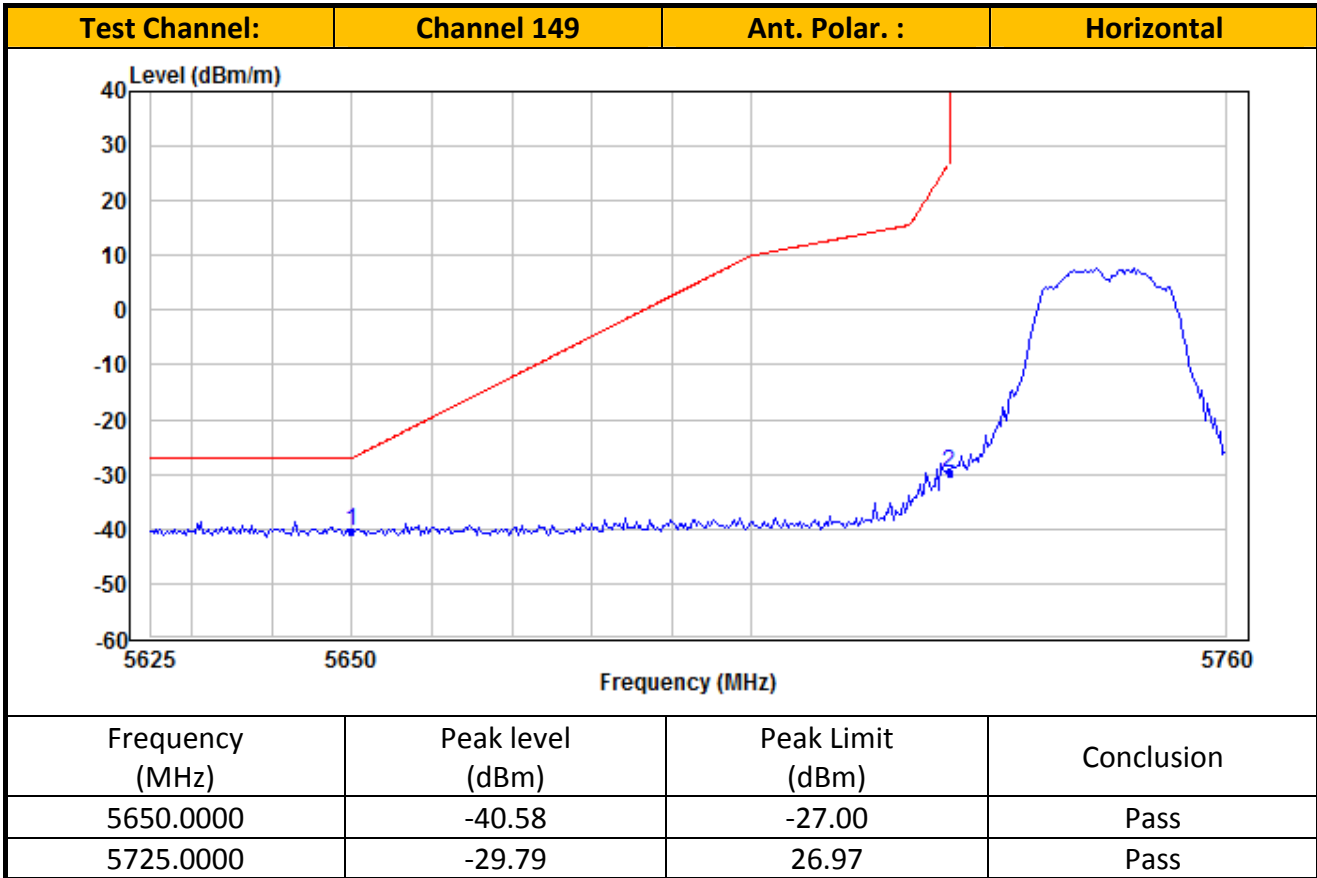

TEST REPORT

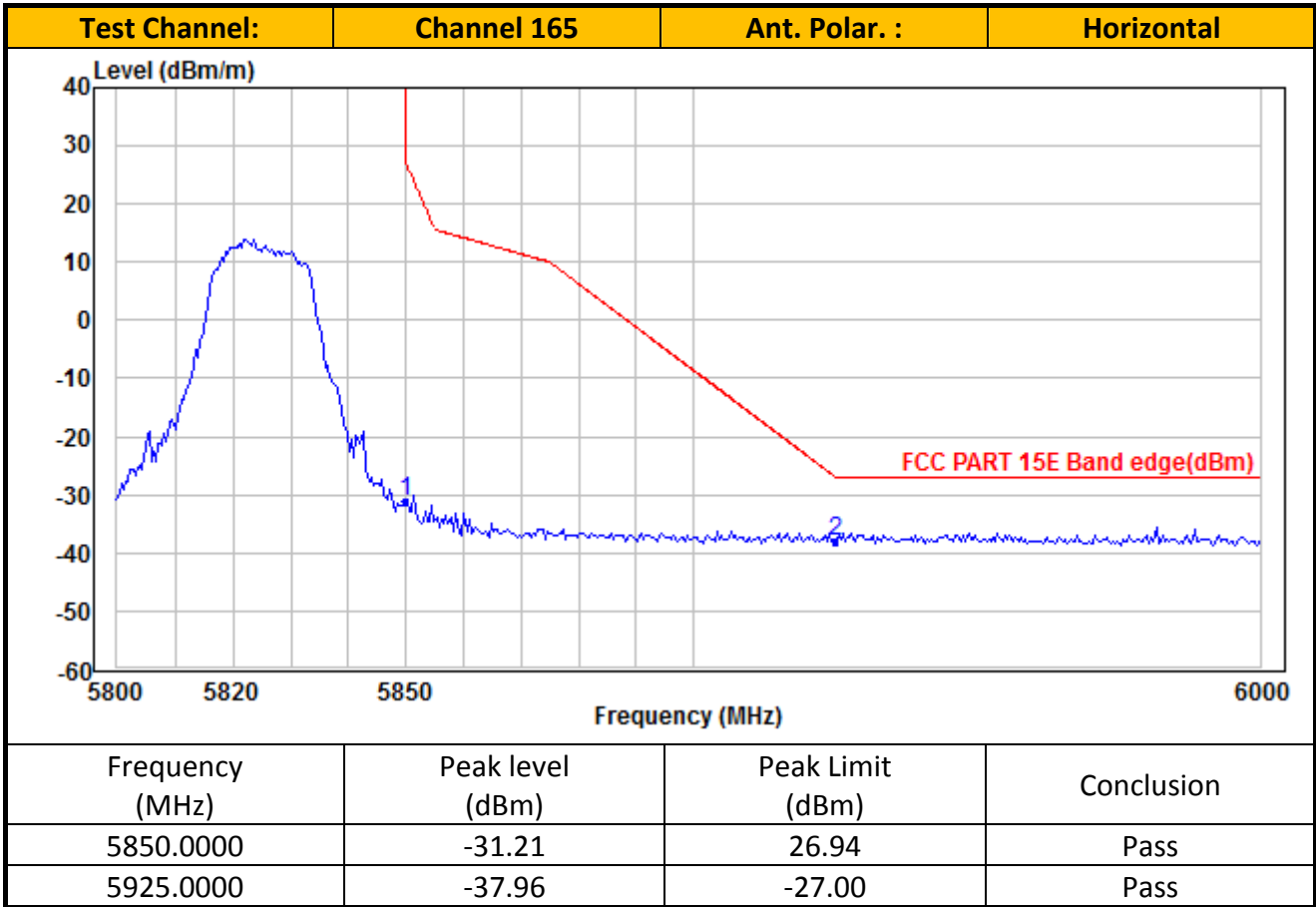

TEST REPORT

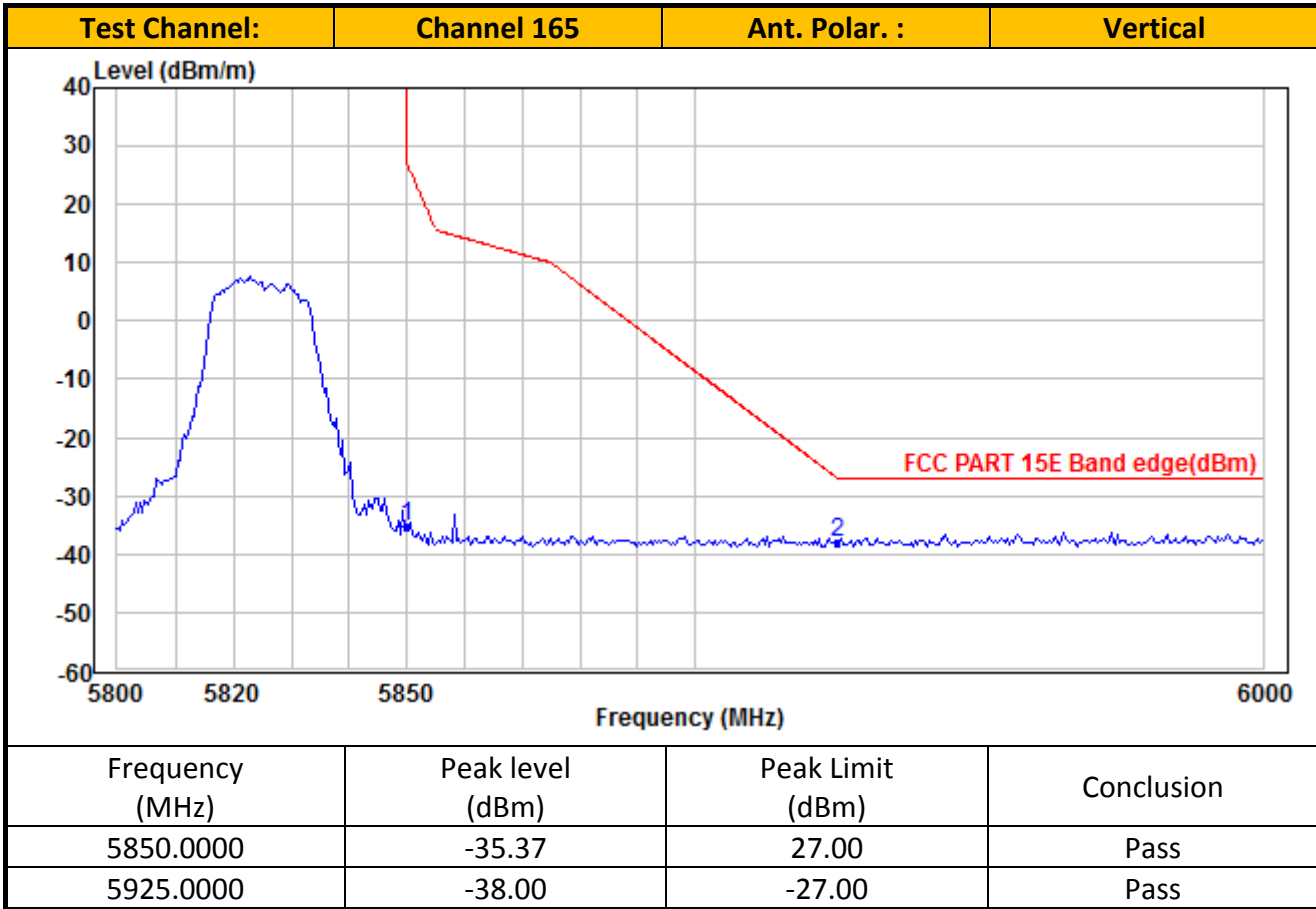

- NOTES:
1. Peak detector is used for the emission measurement.
 2. Average detector is used for the average data of emission measurement
 3. All measurements were made at 3 meters. Radiated emissions not detected at the 3-meter distance were measured at 0.3-meter and an inverse proportional extrapolation was performed to compare the signal level to the 3-meter limit. No other radiated emissions than those reported were detected at a test distance of 0.3-meter.
 4. Value in the margin column shows emission below limit.
 5. Horn antenna is used for the emission over 1000MHz.
 6. Emission (the row indicated by ***bold italic***) within the restricted band meets the requirement of FCC Part 15 Section 15.205.
 7. For the measurement of radiated emission, summation method was used which numerical integrating (in terms of linear power) over the transmitter occupied bandwidth.
 8. For the linear power measurement, data in 1MHz spacing was collected by spectrum analyzer with 1MHz resolution bandwidth.

TEST REPORT

Frequency: 5190MHz
Ant. 1_IIEEE 802.11n (40MHz) (MCS0)

IEEE 802.11n-HT40_Channel 38

No.	Frequency (MHz)	Reading (dBuV/m)	Correction factor (dB)	Result (dBuV/m)	Limit (dBuV/m)	Margin (dB)	Detector	Antenna Polaxis
1	10380.00	40.89	11.17	52.06	74.00	21.94	Peak	Horizontal
2	10380.00	28.73	11.17	39.90	54.00	14.10	Average	Horizontal
3	15570.00	38.60	10.84	49.44	74.00	24.56	Peak	Horizontal
4	15570.00	25.81	10.84	36.65	54.00	17.35	Average	Horizontal
5	10380.00	38.53	9.41	47.94	74.00	26.06	Peak	Vertical
6	10380.00	27.29	9.41	36.70	54.00	17.30	Average	Vertical
7	15570.00	39.07	11.69	50.76	74.00	23.24	Peak	Vertical
8	15570.00	26.39	11.69	38.08	54.00	15.92	Average	Vertical

IEEE 802.11n-HT40_Channel 46

No.	Frequency (MHz)	Reading (dBuV/m)	Correction factor (dB)	Result (dBuV/m)	Limit (dBuV/m)	Margin (dB)	Detector	Antenna Polaxis
1	10460.00	39.90	11.35	51.25	74.00	22.75	Peak	Horizontal
2	10460.00	28.69	11.35	40.04	54.00	13.96	Average	Horizontal
3	15690.00	42.17	11.03	53.20	74.00	20.80	Peak	Horizontal
4	15690.00	28.04	11.03	39.07	54.00	14.93	Average	Horizontal
5	10460.00	39.46	9.43	48.89	74.00	25.11	Peak	Vertical
6	10460.00	27.60	9.43	37.03	54.00	16.97	Average	Vertical
7	15690.00	40.86	11.98	52.84	74.00	21.16	Peak	Vertical
8	15690.00	27.62	11.98	39.60	54.00	14.40	Average	Vertical

IEEE 802.11n-HT40_Channel 54

No.	Frequency (MHz)	Reading (dBuV/m)	Correction factor (dB)	Result (dBuV/m)	Limit (dBuV/m)	Margin (dB)	Detector	Antenna Polaxis
1	10540.00	39.98	11.41	51.39	74.00	22.61	Peak	Horizontal
2	10540.00	28.15	11.41	39.56	54.00	14.44	Average	Horizontal
3	15810.00	37.21	11.21	48.42	74.00	25.58	Peak	Horizontal
4	15810.00	24.48	11.21	35.69	54.00	18.31	Average	Horizontal
5	10540.00	39.47	9.42	48.89	74.00	25.11	Peak	Vertical
6	10540.00	27.09	9.42	36.51	54.00	17.49	Average	Vertical
7	15810.00	39.85	12.26	52.11	74.00	21.89	Peak	Vertical
8	15810.00	27.33	12.26	39.59	54.00	14.41	Average	Vertical

TEST REPORT

IEEE 802.11n-HT40_Channel 62

No.	Frequency (MHz)	Reading (dBuV/m)	Correction factor (dB)	Result (dBuV/m)	Limit (dBuV/m)	Margin (dB)	Detector	Antenna Polaxis
1	10620.00	39.66	11.30	50.96	74.00	23.04	Peak	Horizontal
2	10620.00	28.15	11.30	39.45	54.00	14.55	Average	Horizontal
3	15930.00	38.60	11.41	50.01	74.00	23.99	Peak	Horizontal
4	15930.00	25.79	11.41	37.20	54.00	16.80	Average	Horizontal
5	10620.00	38.79	9.35	48.14	74.00	25.86	Peak	Vertical
6	10620.00	26.98	9.35	36.33	54.00	17.67	Average	Vertical
7	15930.00	38.68	12.56	51.24	74.00	22.76	Peak	Vertical
8	15930.00	25.52	12.56	38.08	54.00	15.92	Average	Vertical

IEEE 802.11n-HT40_Channel 102

No.	Frequency (MHz)	Reading (dBuV/m)	Correction factor (dB)	Result (dBuV/m)	Limit (dBuV/m)	Margin (dB)	Detector	Antenna Polaxis
1	11020.00	40.97	10.24	51.21	74.00	22.79	Peak	Horizontal
2	11020.00	28.73	10.24	38.97	54.00	15.03	Average	Horizontal
3	16530.00	38.98	13.34	52.32	74.00	21.68	Peak	Horizontal
4	16530.00	26.31	13.34	39.65	54.00	14.35	Average	Horizontal
5	11020.00	40.34	8.45	48.79	74.00	25.21	Peak	Vertical
6	11020.00	28.40	8.45	36.85	54.00	17.15	Average	Vertical
7	16530.00	37.94	13.40	51.34	74.00	22.66	Peak	Vertical
8	16530.00	25.23	13.40	38.63	54.00	15.37	Average	Vertical

IEEE 802.11n-HT40_Channel 110

No.	Frequency (MHz)	Reading (dBuV/m)	Correction factor (dB)	Result (dBuV/m)	Limit (dBuV/m)	Margin (dB)	Detector	Antenna Polaxis
1	11100.00	41.00	10.30	51.30	74.00	22.70	Peak	Horizontal
2	11100.00	28.99	10.30	39.29	54.00	14.71	Average	Horizontal
3	16650.00	37.28	13.29	50.57	74.00	23.43	Peak	Horizontal
4	16650.00	25.63	13.29	38.92	54.00	15.08	Average	Horizontal
5	11100.00	40.04	8.50	48.54	74.00	25.46	Peak	Vertical
6	11100.00	28.29	8.50	36.79	54.00	17.21	Average	Vertical
7	16650.00	37.34	13.18	50.52	74.00	23.48	Peak	Vertical
8	16650.00	25.41	13.18	38.59	54.00	15.41	Average	Vertical

TEST REPORT

IEEE 802.11n-HT40_Channel 134

No.	Frequency (MHz)	Reading (dBuV/m)	Correction factor (dB)	Result (dBuV/m)	Limit (dBuV/m)	Margin (dB)	Detector	Antenna Polaxis
1	11340.00	40.44	9.89	50.33	74.00	23.67	Peak	Horizontal
2	11340.00	40.44	9.89	38.63	54.00	15.37	Average	Horizontal
3	17010.00	40.44	9.82	50.26	74.00	23.74	Peak	Horizontal
4	17010.00	40.44	9.82	38.34	54.00	15.66	Average	Horizontal
5	11340.00	40.44	9.11	49.55	74.00	24.45	Peak	Vertical
6	11340.00	40.44	9.11	37.34	54.00	16.66	Average	Vertical
7	17010.00	40.44	12.87	53.31	74.00	20.69	Peak	Vertical
8	17010.00	40.44	12.87	37.99	54.00	16.01	Average	Vertical

IEEE 802.11n-HT40_Channel 151

No.	Frequency (MHz)	Reading (dBuV/m)	Correction factor (dB)	Result (dBuV/m)	Limit (dBuV/m)	Margin (dB)	Detector	Antenna Polaxis
1	11510.00	41.40	9.79	51.19	74.00	22.81	Peak	Horizontal
2	11510.00	28.79	9.79	38.58	54.00	15.42	Average	Horizontal
3	17265.00	41.46	14.11	55.57	74.00	18.43	Peak	Horizontal
4	17265.00	28.73	14.11	42.84	54.00	11.16	Average	Horizontal
5	11510.00	41.76	8.30	50.06	74.00	23.94	Peak	Vertical
6	11510.00	28.82	8.30	37.12	54.00	16.88	Average	Vertical
7	17265.00	39.14	13.35	52.49	74.00	21.51	Peak	Vertical
8	17265.00	25.87	13.35	39.22	54.00	14.78	Average	Vertical

IEEE 802.11n-HT40_Channel 159

No.	Frequency (MHz)	Reading (dBuV/m)	Correction factor (dB)	Result (dBuV/m)	Limit (dBuV/m)	Margin (dB)	Detector	Antenna Polaxis
1	11590.00	40.78	9.87	50.65	74.00	23.35	Peak	Horizontal
2	11590.00	28.25	9.87	38.12	54.00	15.88	Average	Horizontal
3	17385.00	38.75	14.62	53.37	74.00	20.63	Peak	Horizontal
4	17385.00	27.23	14.62	41.85	54.00	12.15	Average	Horizontal
5	11590.00	40.17	8.52	48.69	74.00	25.31	Peak	Vertical
6	11590.00	28.07	8.52	36.59	54.00	17.41	Average	Vertical
7	17385.00	39.95	13.79	53.74	74.00	20.26	Peak	Vertical
8	17385.00	27.54	13.79	41.33	54.00	12.67	Average	Vertical

TEST REPORT

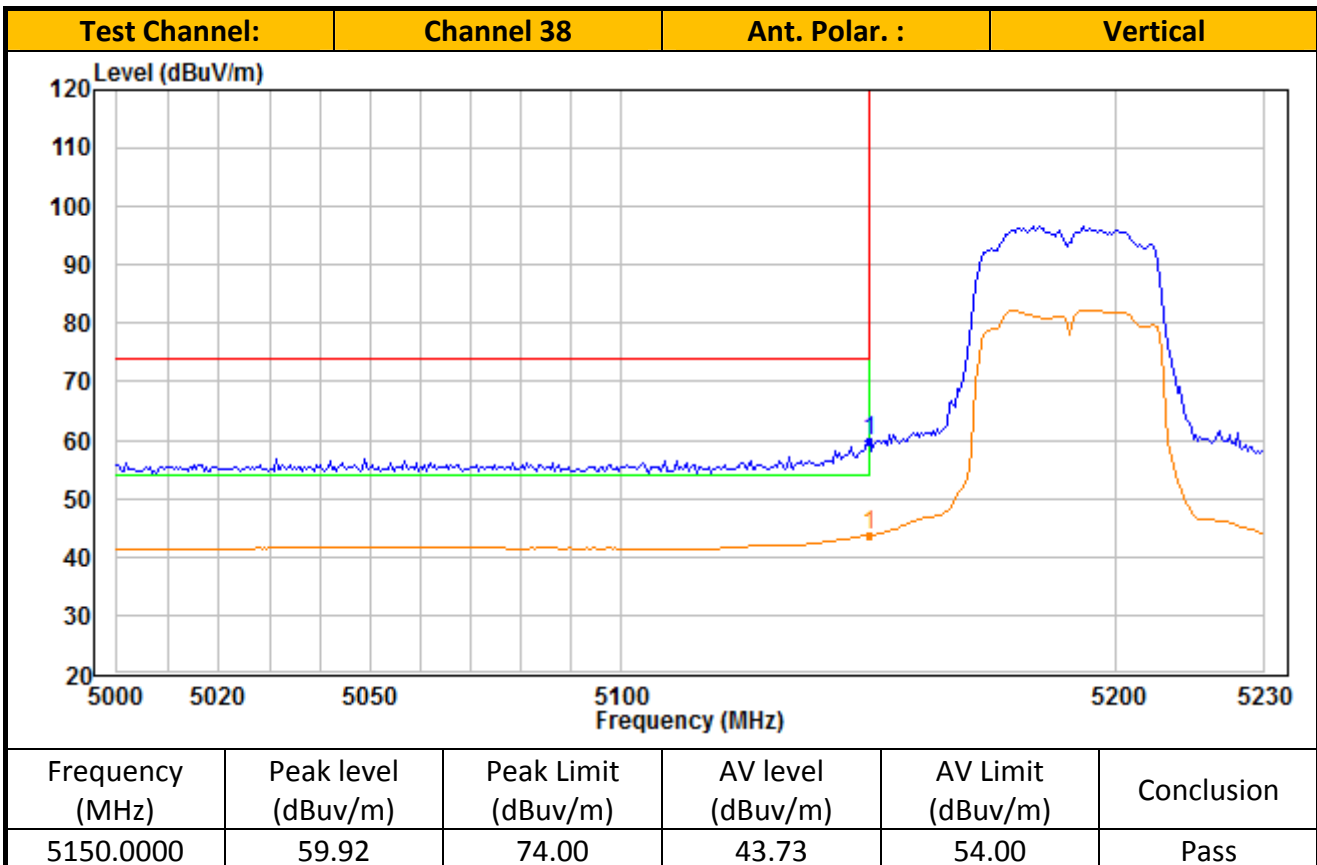
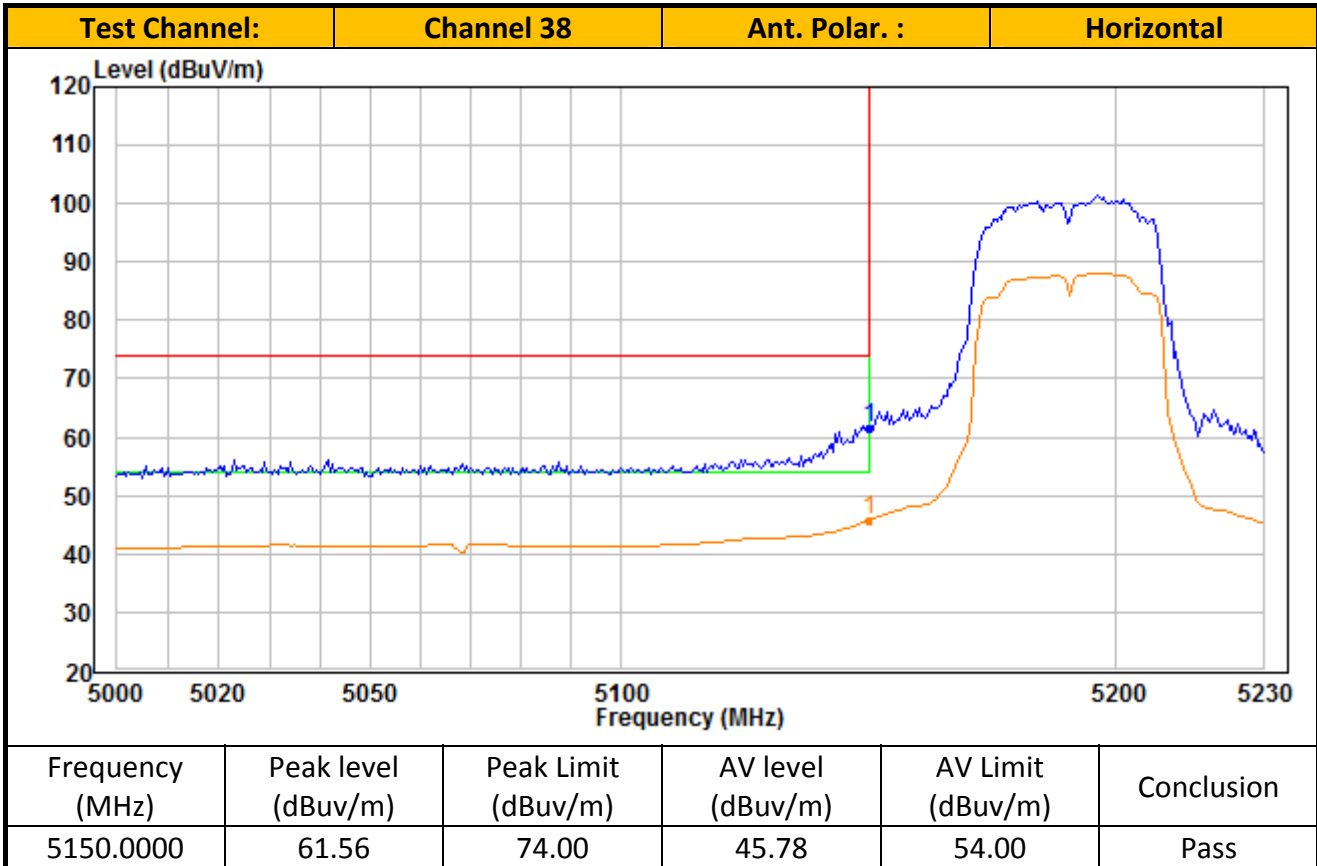

TEST REPORT

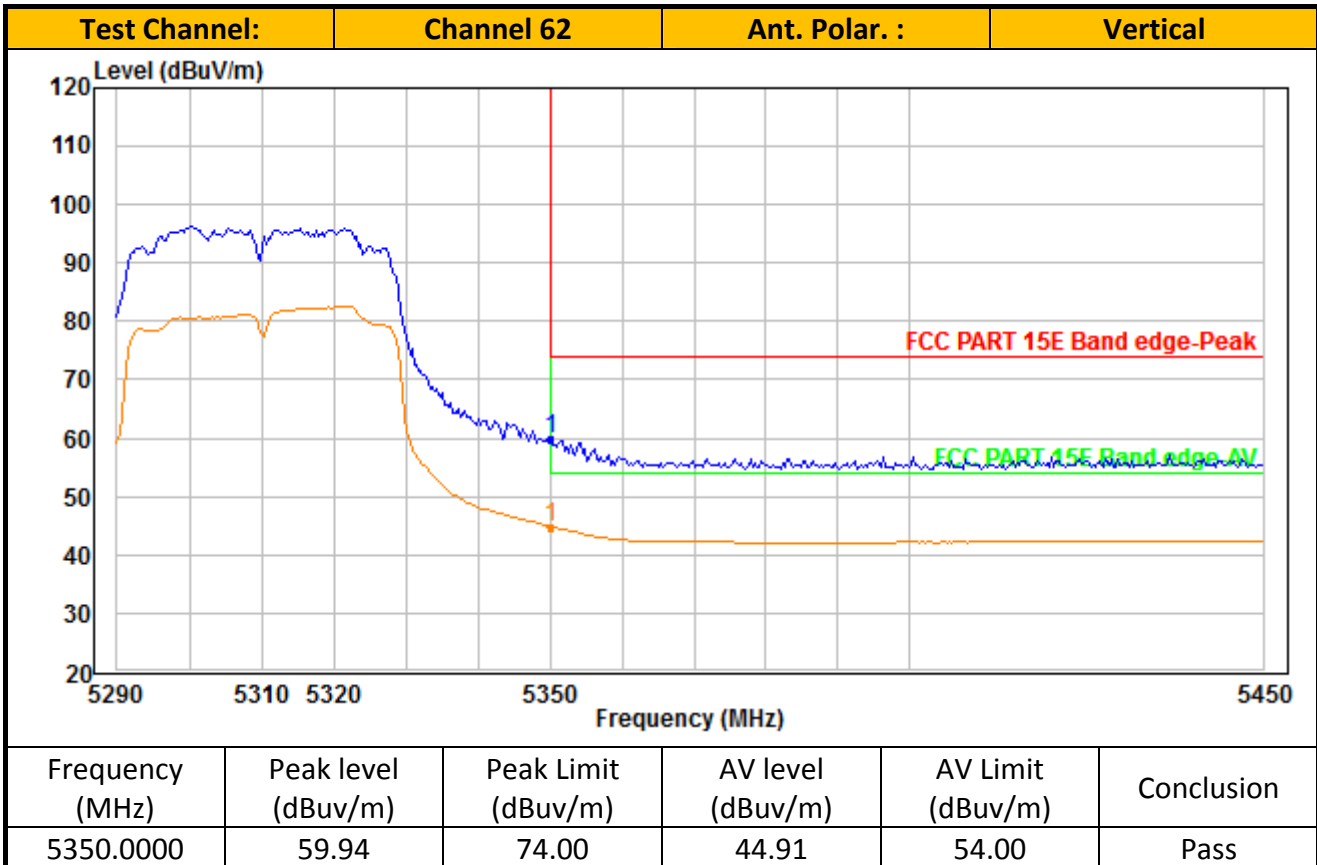
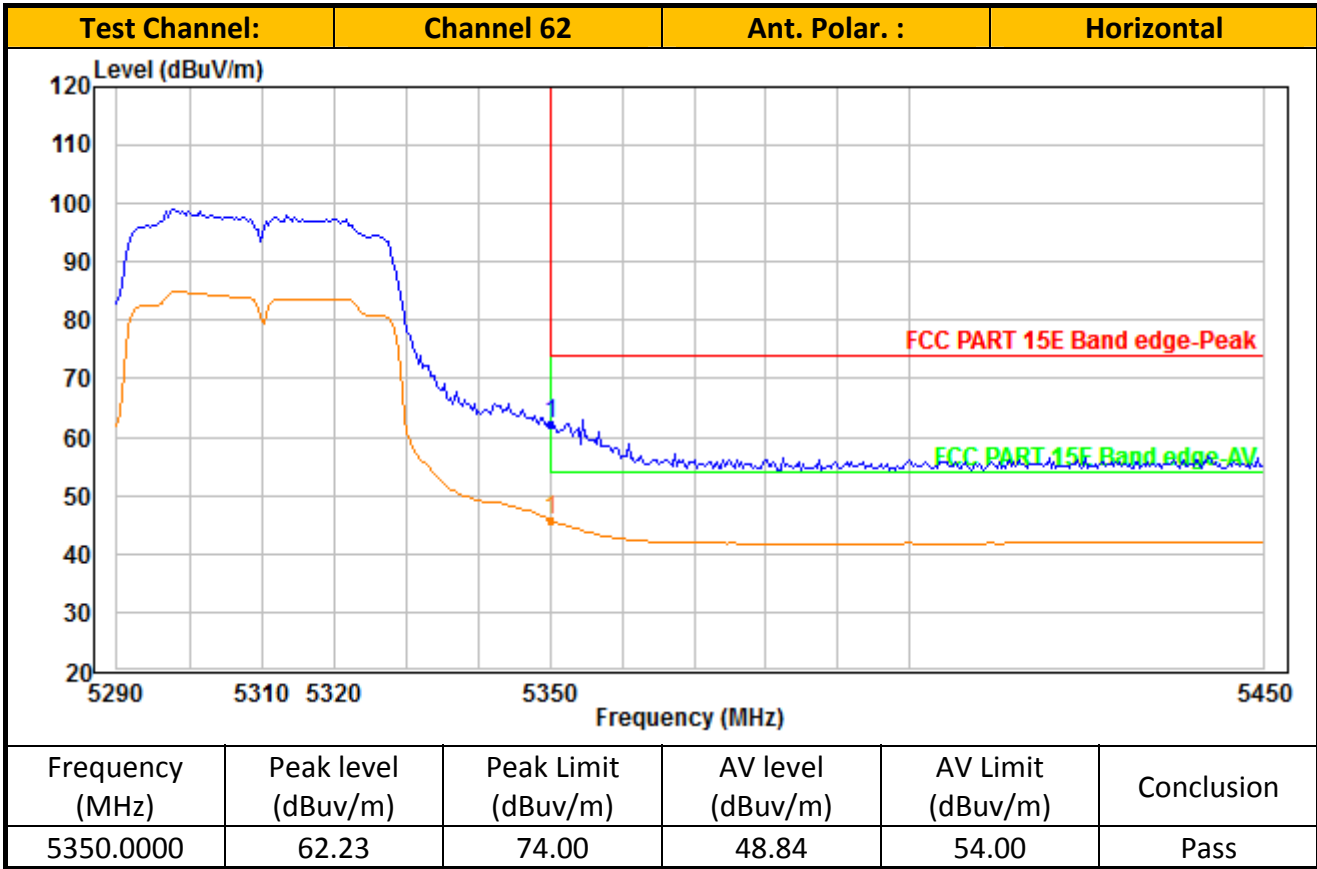

TEST REPORT

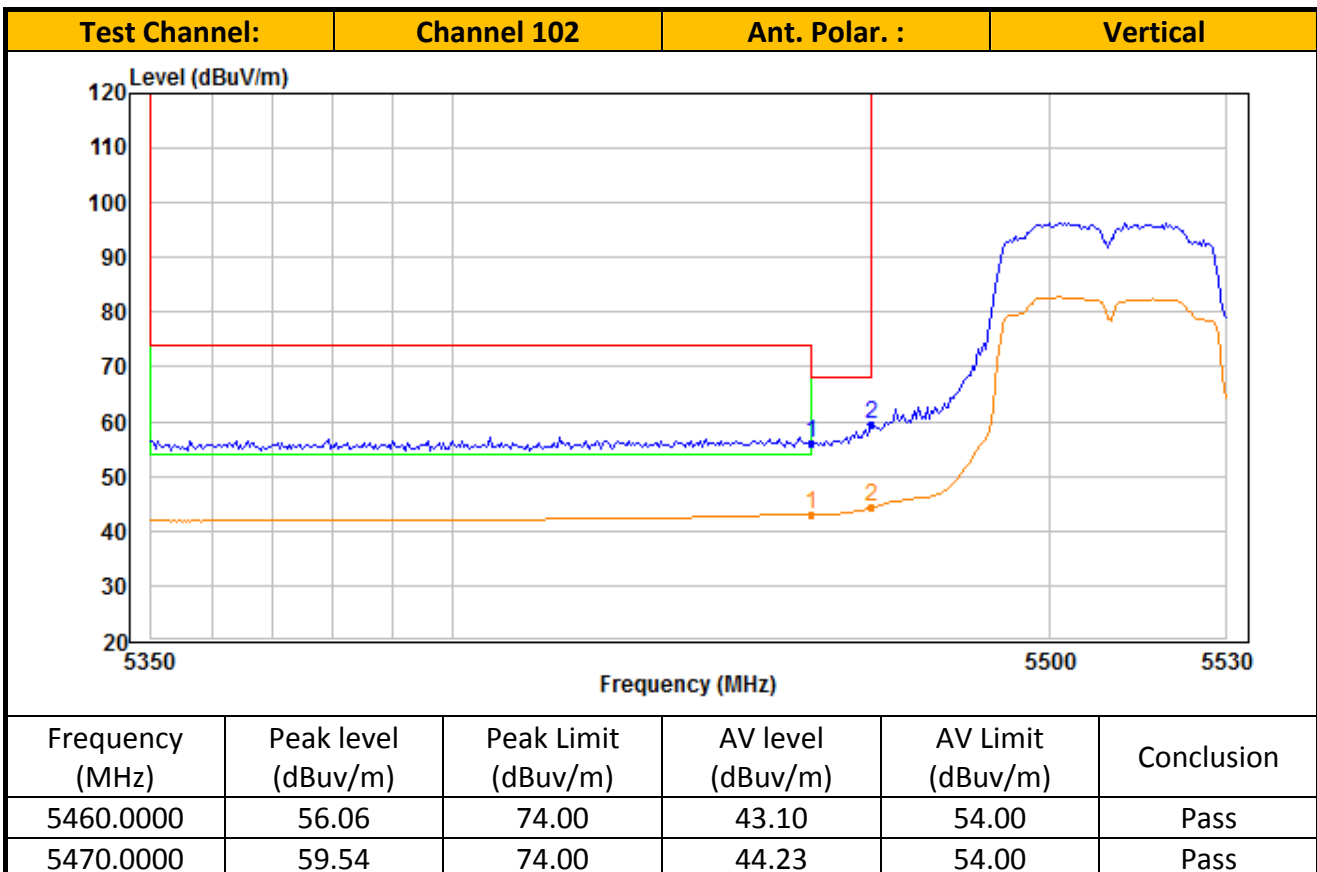
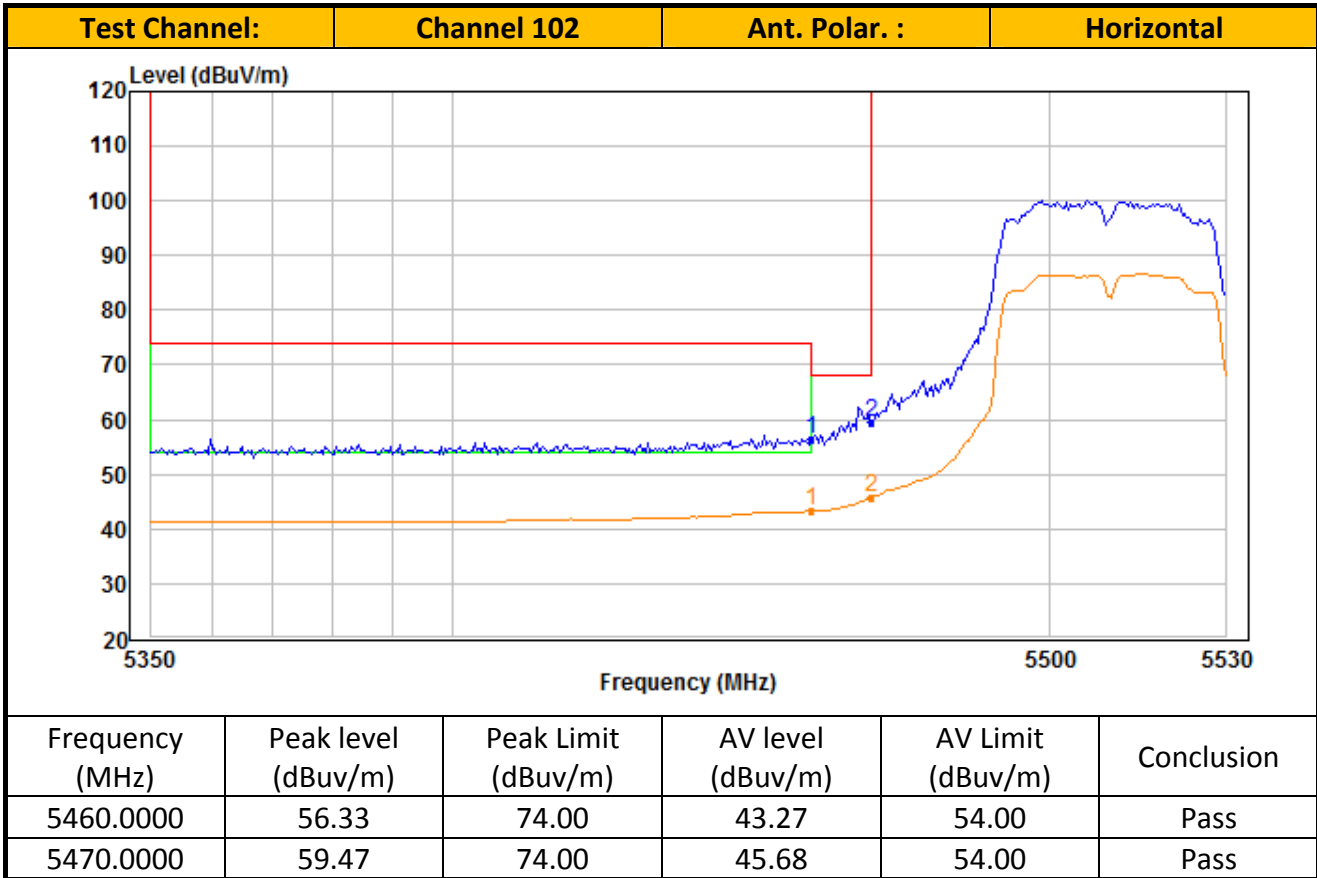

TEST REPORT

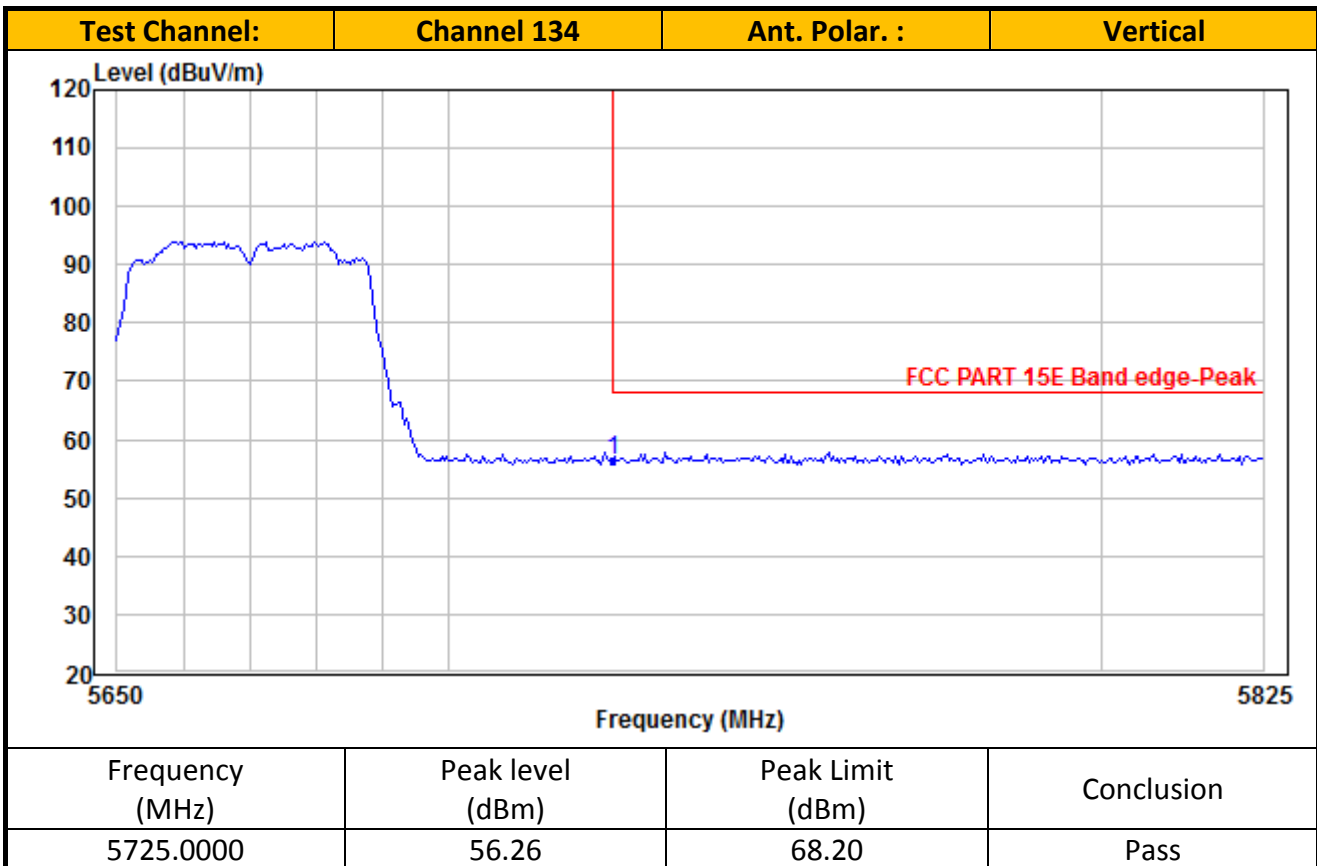
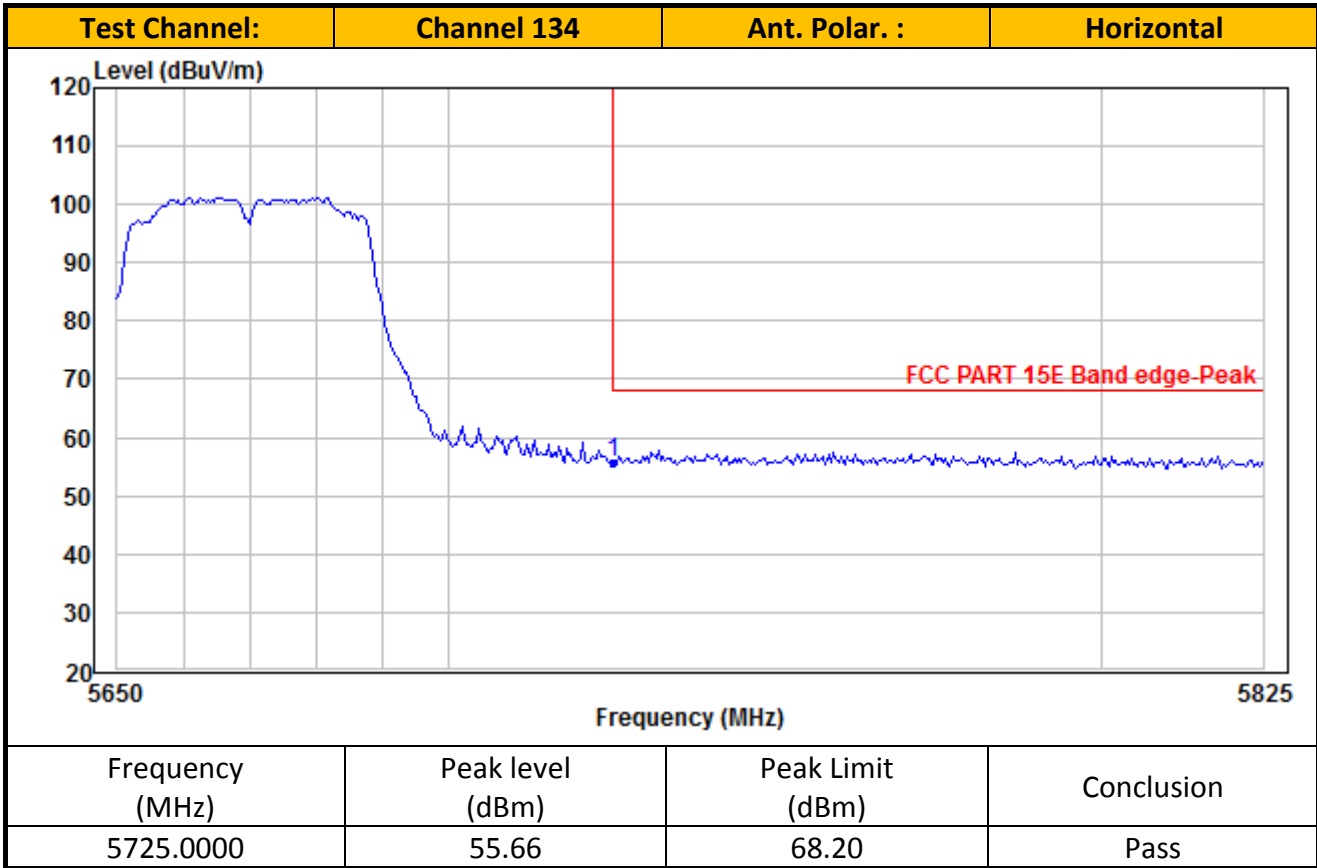

TEST REPORT

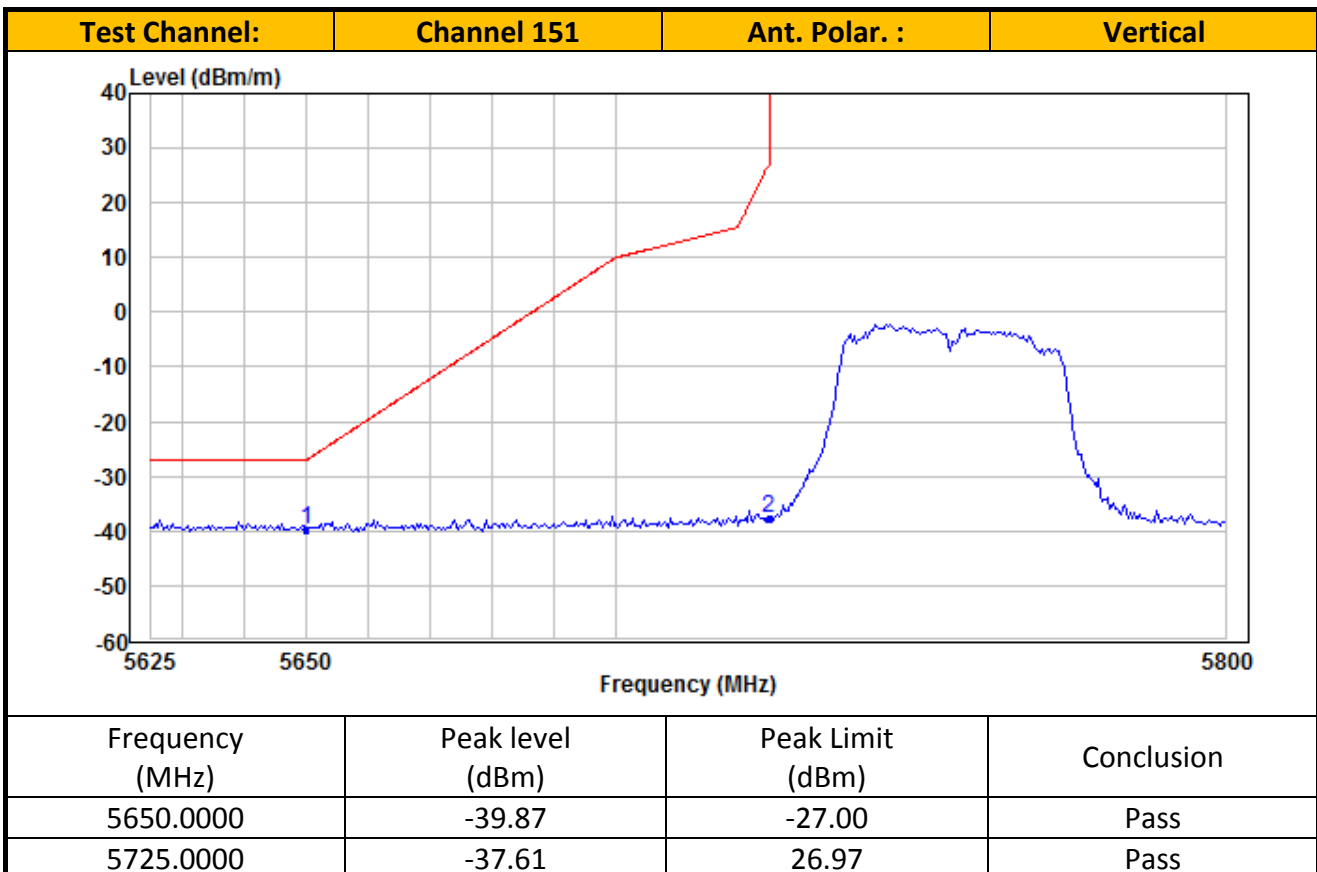
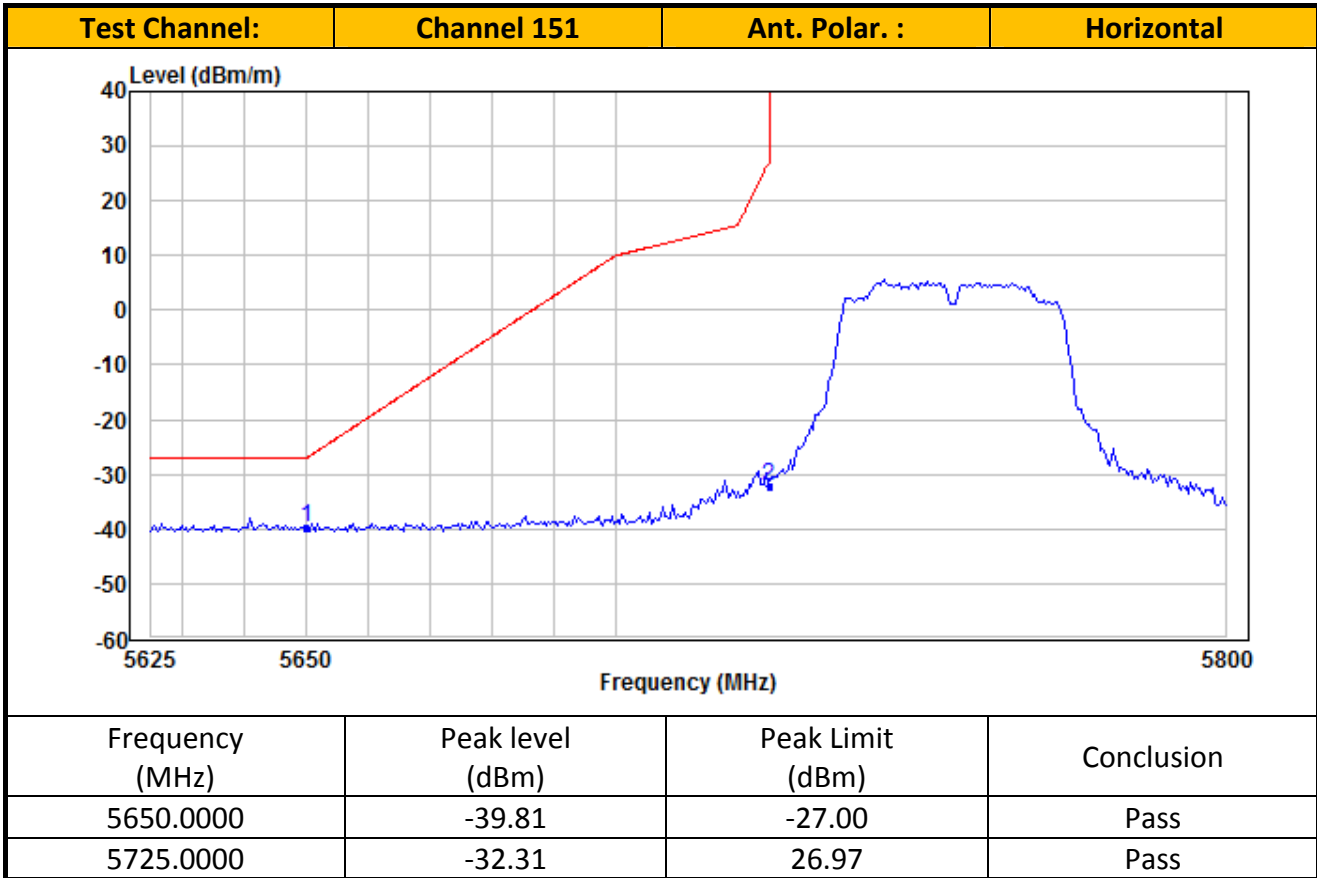

TEST REPORT

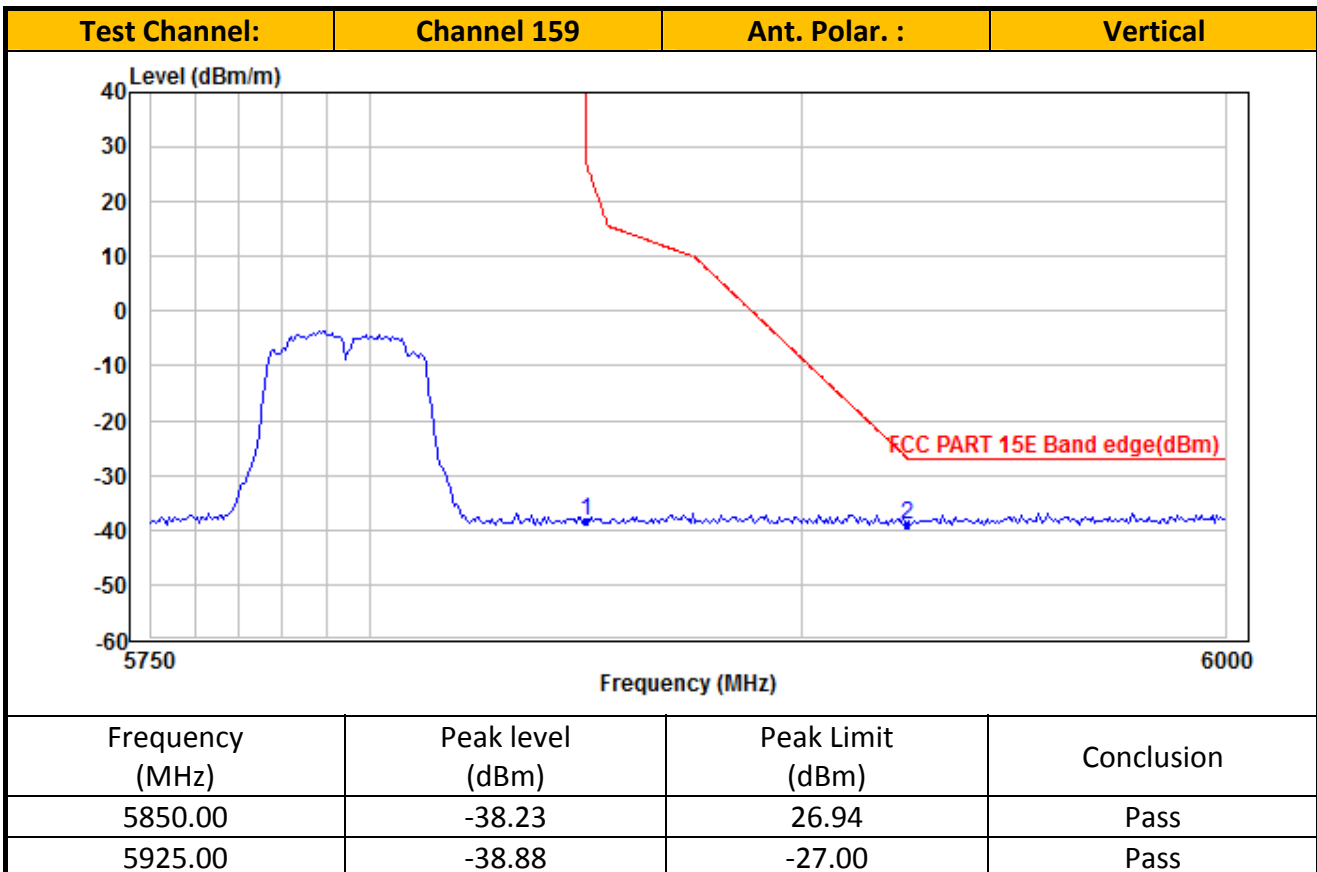
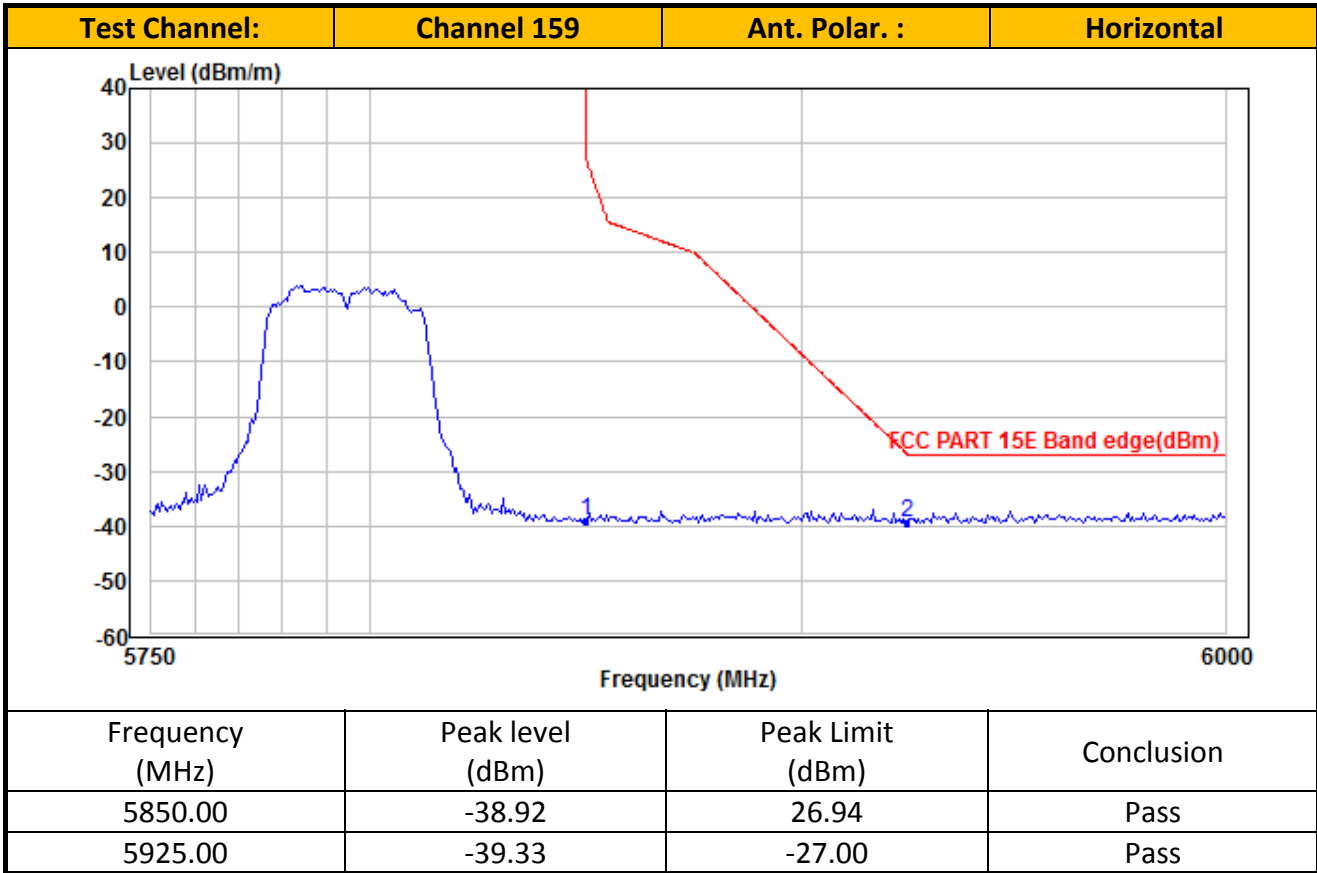

TEST REPORT

Ant. 2_ IEEE 802.11n (40MHz) (MCS0)

IEEE 802.11n-HT40_Channel 38

No.	Frequency (MHz)	Reading (dBuV/m)	Correction factor (dB)	Result (dBuV/m)	Limit (dBuV/m)	Margin (dB)	Detector	Antenna Polaxis
1	10380.00	41.79	11.17	52.96	74.00	21.04	Peak	Horizontal
2	10380.00	29.44	11.17	40.61	54.00	13.39	Average	Horizontal
3	15570.00	39.19	10.84	50.03	74.00	23.97	Peak	Horizontal
4	15570.00	27.24	10.84	38.08	54.00	15.92	Average	Horizontal
5	10380.00	39.56	9.41	48.97	74.00	25.03	Peak	Vertical
6	10380.00	27.66	9.41	37.07	54.00	16.93	Average	Vertical
7	15570.00	39.34	11.69	51.03	74.00	22.97	Peak	Vertical
8	15570.00	26.87	11.69	38.56	54.00	15.44	Average	Vertical

IEEE 802.11n-HT40_Channel 46

No.	Frequency (MHz)	Reading (dBuV/m)	Correction factor (dB)	Result (dBuV/m)	Limit (dBuV/m)	Margin (dB)	Detector	Antenna Polaxis
1	10460.00	41.75	11.35	53.10	74.00	20.90	Peak	Horizontal
2	10460.00	29.06	11.35	40.41	54.00	13.59	Average	Horizontal
3	15690.00	41.71	11.03	52.74	74.00	21.26	Peak	Horizontal
4	15690.00	27.87	11.03	38.90	54.00	15.10	Average	Horizontal
5	10460.00	41.71	9.43	51.14	74.00	22.86	Peak	Vertical
6	10460.00	28.13	9.43	37.56	54.00	16.44	Average	Vertical
7	15690.00	43.00	11.98	54.98	74.00	19.02	Peak	Vertical
8	15690.00	29.35	11.98	41.33	54.00	12.67	Average	Vertical

IEEE 802.11n-HT40_Channel 54

No.	Frequency (MHz)	Reading (dBuV/m)	Correction factor (dB)	Result (dBuV/m)	Limit (dBuV/m)	Margin (dB)	Detector	Antenna Polaxis
1	10540.00	41.55	11.41	52.96	74.00	21.04	Peak	Horizontal
2	10540.00	28.59	11.41	40.00	54.00	14.00	Average	Horizontal
3	15810.00	38.16	11.21	49.37	74.00	24.63	Peak	Horizontal
4	15810.00	24.65	11.21	35.86	54.00	18.14	Average	Horizontal
5	10540.00	39.53	9.42	48.95	74.00	25.05	Peak	Vertical
6	10540.00	27.46	9.42	36.88	54.00	17.12	Average	Vertical
7	15810.00	44.29	12.26	56.55	74.00	17.45	Peak	Vertical
8	15810.00	25.33	12.26	37.59	54.00	16.41	Average	Vertical

TEST REPORT

IEEE 802.11n-HT40_Channel 62

No.	Frequency (MHz)	Reading (dBuV/m)	Correction factor (dB)	Result (dBuV/m)	Limit (dBuV/m)	Margin (dB)	Detector	Antenna Polaxis
1	10620.00	40.53	11.30	51.83	74.00	22.17	Peak	Horizontal
2	10620.00	28.84	11.30	40.14	54.00	13.86	Average	Horizontal
3	15930.00	39.20	12.03	51.23	74.00	22.77	Peak	Horizontal
4	15930.00	25.05	12.03	37.08	54.00	16.92	Average	Horizontal
5	10620.00	39.88	9.35	49.23	74.00	24.77	Peak	Vertical
6	10620.00	27.17	9.35	36.52	54.00	17.48	Average	Vertical
7	15930.00	41.38	12.56	53.94	74.00	20.06	Peak	Vertical
8	15930.00	26.32	12.56	38.88	54.00	15.12	Average	Vertical

IEEE 802.11n-HT40_Channel 102

No.	Frequency (MHz)	Reading (dBuV/m)	Correction factor (dB)	Result (dBuV/m)	Limit (dBuV/m)	Margin (dB)	Detector	Antenna Polaxis
1	11020.00	41.56	10.24	51.80	74.00	22.20	Peak	Horizontal
2	11020.00	29.25	10.24	39.49	54.00	14.51	Average	Horizontal
3	16530.00	40.21	13.34	53.55	74.00	20.45	Peak	Horizontal
4	16530.00	25.73	13.34	39.07	54.00	14.93	Average	Horizontal
5	11020.00	40.69	8.45	49.14	74.00	24.86	Peak	Vertical
6	11020.00	28.62	8.45	37.07	54.00	16.93	Average	Vertical
7	16530.00	42.10	13.40	55.50	74.00	18.50	Peak	Vertical
8	16530.00	26.21	13.40	39.61	54.00	14.39	Average	Vertical

IEEE 802.11n-HT40_Channel 110

No.	Frequency (MHz)	Reading (dBuV/m)	Correction factor (dB)	Result (dBuV/m)	Limit (dBuV/m)	Margin (dB)	Detector	Antenna Polaxis
1	11100.00	41.25	10.00	51.25	74.00	22.75	Peak	Horizontal
2	11100.00	28.51	10.00	38.51	54.00	15.49	Average	Horizontal
3	16650.00	39.01	13.29	52.30	74.00	21.70	Peak	Horizontal
4	16650.00	26.00	13.29	39.29	54.00	14.71	Average	Horizontal
5	11100.00	40.19	8.26	48.45	74.00	25.55	Peak	Vertical
6	11100.00	28.02	8.26	36.28	54.00	17.72	Average	Vertical
7	16650.00	40.55	13.18	53.73	74.00	20.27	Peak	Vertical
8	16650.00	25.49	13.18	38.67	54.00	15.33	Average	Vertical

TEST REPORT

IEEE 802.11n-HT40_Channel 134

No.	Frequency (MHz)	Reading (dBuV/m)	Correction factor (dB)	Result (dBuV/m)	Limit (dBuV/m)	Margin (dB)	Detector	Antenna Polaxis
1	11340.00	41.13	9.89	51.02	74.00	22.98	Peak	Horizontal
2	11340.00	29.10	9.89	38.99	54.00	15.01	Average	Horizontal
3	17010.00	38.18	13.18	51.36	74.00	22.64	Peak	Horizontal
4	17010.00	25.55	13.18	38.73	54.00	15.27	Average	Horizontal
5	11340.00	40.44	8.29	48.73	74.00	25.27	Peak	Vertical
6	11340.00	28.84	8.29	37.13	54.00	16.87	Average	Vertical
7	17010.00	36.48	12.57	49.05	74.00	24.95	Peak	Vertical
8	17010.00	24.35	12.57	36.92	54.00	17.08	Average	Vertical

IEEE 802.11n-HT40_Channel 151

No.	Frequency (MHz)	Reading (dBuV/m)	Correction factor (dB)	Result (dBuV/m)	Limit (dBuV/m)	Margin (dB)	Detector	Antenna Polaxis
1	11510.00	42.52	9.79	52.31	74.00	21.69	Peak	Horizontal
2	11510.00	29.35	9.79	39.14	54.00	14.86	Average	Horizontal
3	17265.00	39.25	14.11	53.36	74.00	20.64	Peak	Horizontal
4	17265.00	26.60	14.11	40.71	54.00	13.29	Average	Horizontal
5	11510.00	43.00	8.50	51.50	74.00	22.50	Peak	Vertical
6	11510.00	29.13	8.50	37.63	54.00	16.37	Average	Vertical
7	17265.00	39.27	13.35	52.62	74.00	21.38	Peak	Vertical
8	17265.00	26.16	13.35	39.51	54.00	14.49	Average	Vertical

IEEE 802.11n-HT40_Channel 159

No.	Frequency (MHz)	Reading (dBuV/m)	Correction factor (dB)	Result (dBuV/m)	Limit (dBuV/m)	Margin (dB)	Detector	Antenna Polaxis
1	11590.00	41.08	9.87	50.95	74.00	23.05	Peak	Horizontal
2	11590.00	28.69	9.87	38.56	54.00	15.44	Average	Horizontal
3	17385.00	38.93	14.62	53.55	74.00	20.45	Peak	Horizontal
4	17385.00	27.66	14.62	42.28	54.00	11.72	Average	Horizontal
5	11590.00	41.52	8.52	50.04	74.00	23.96	Peak	Vertical
6	11590.00	28.63	8.52	37.15	54.00	16.85	Average	Vertical
7	17385.00	39.98	13.79	53.77	74.00	20.23	Peak	Vertical
8	17385.00	27.66	13.79	41.45	54.00	12.55	Average	Vertical

TEST REPORT

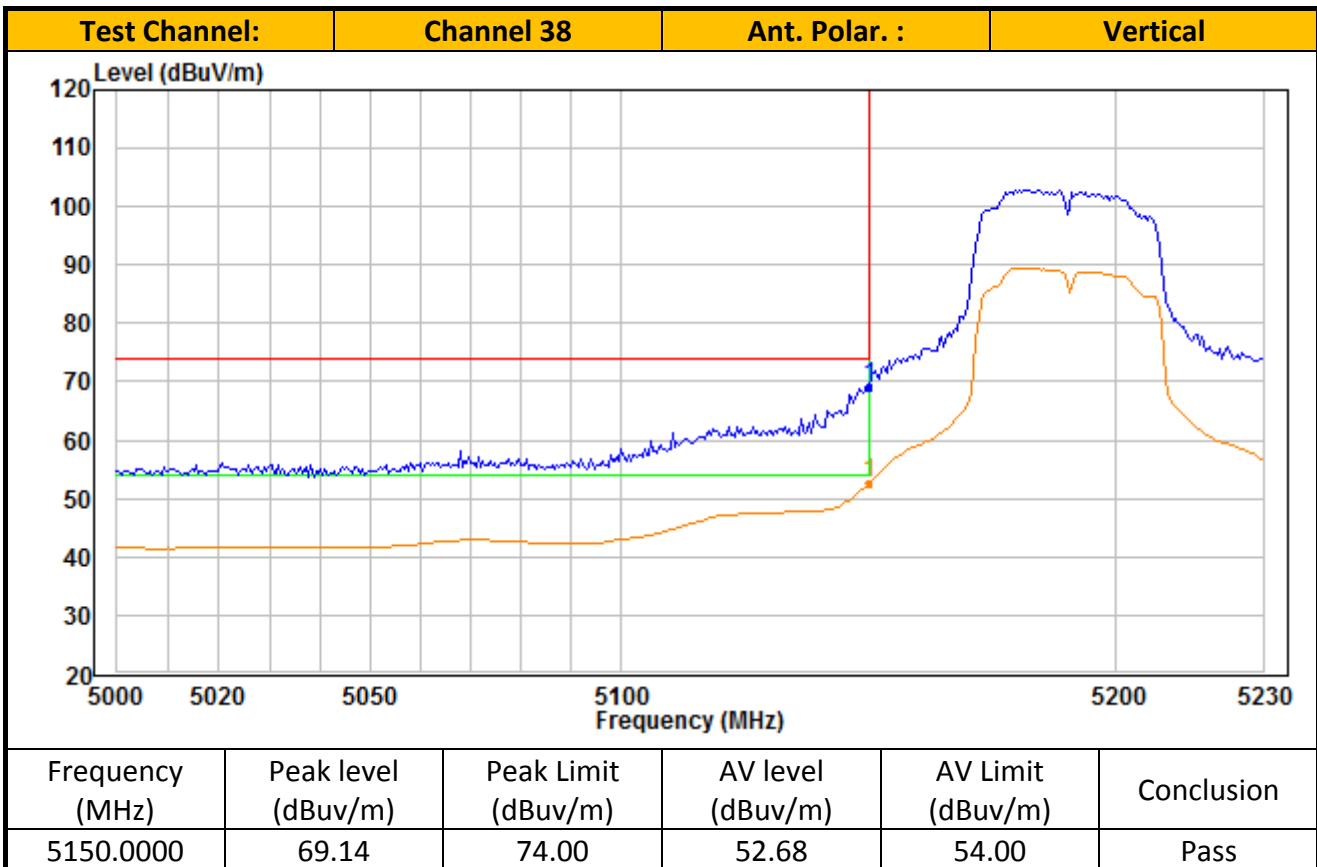
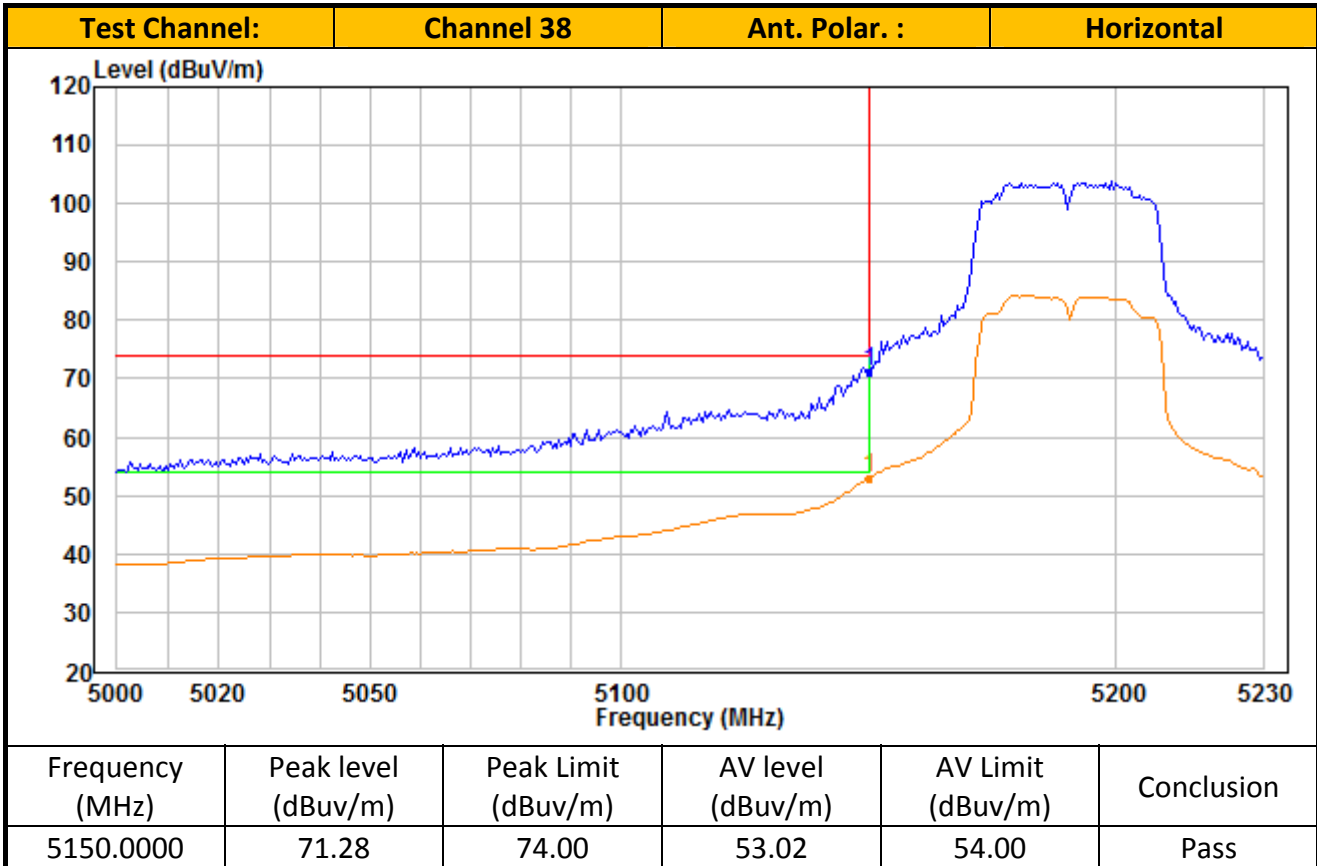

TEST REPORT

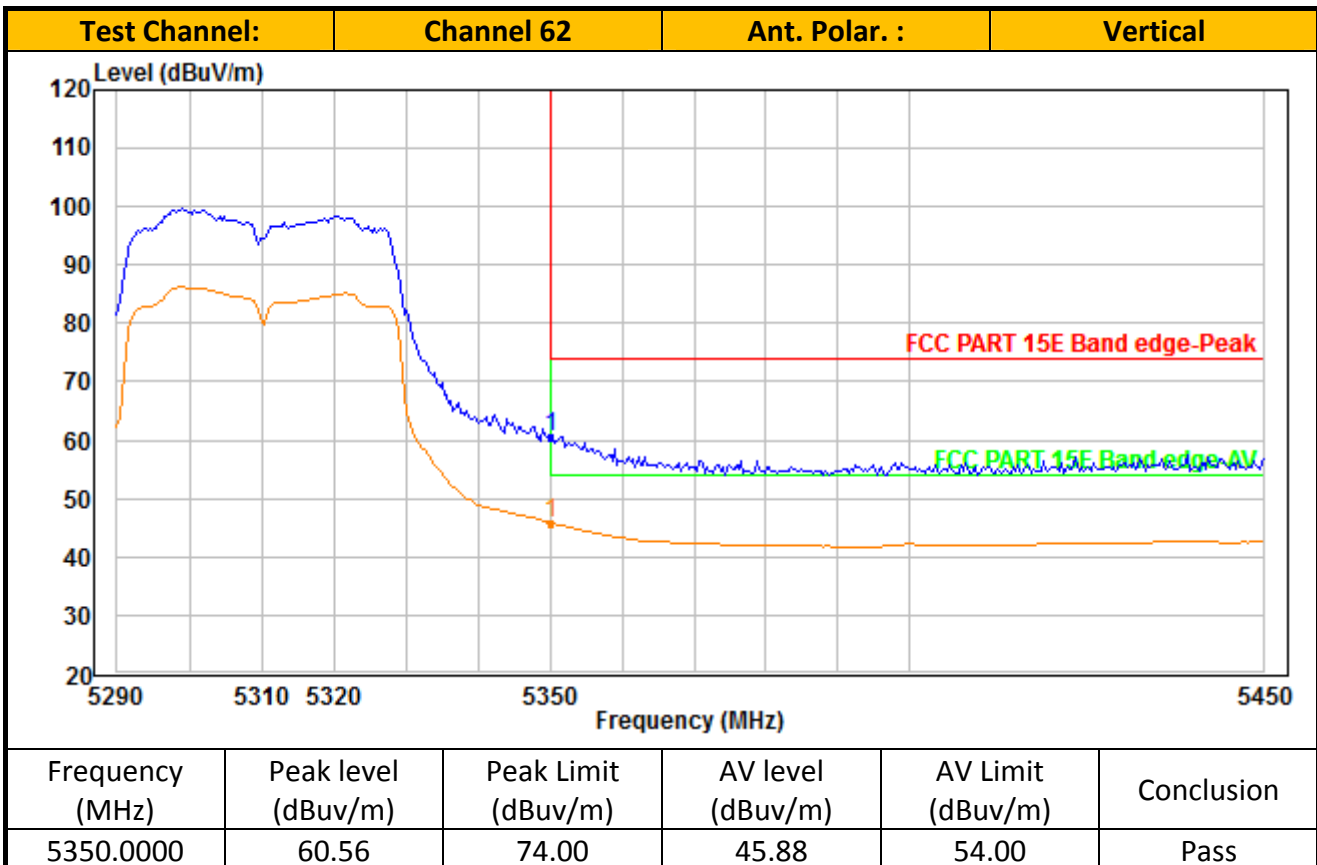
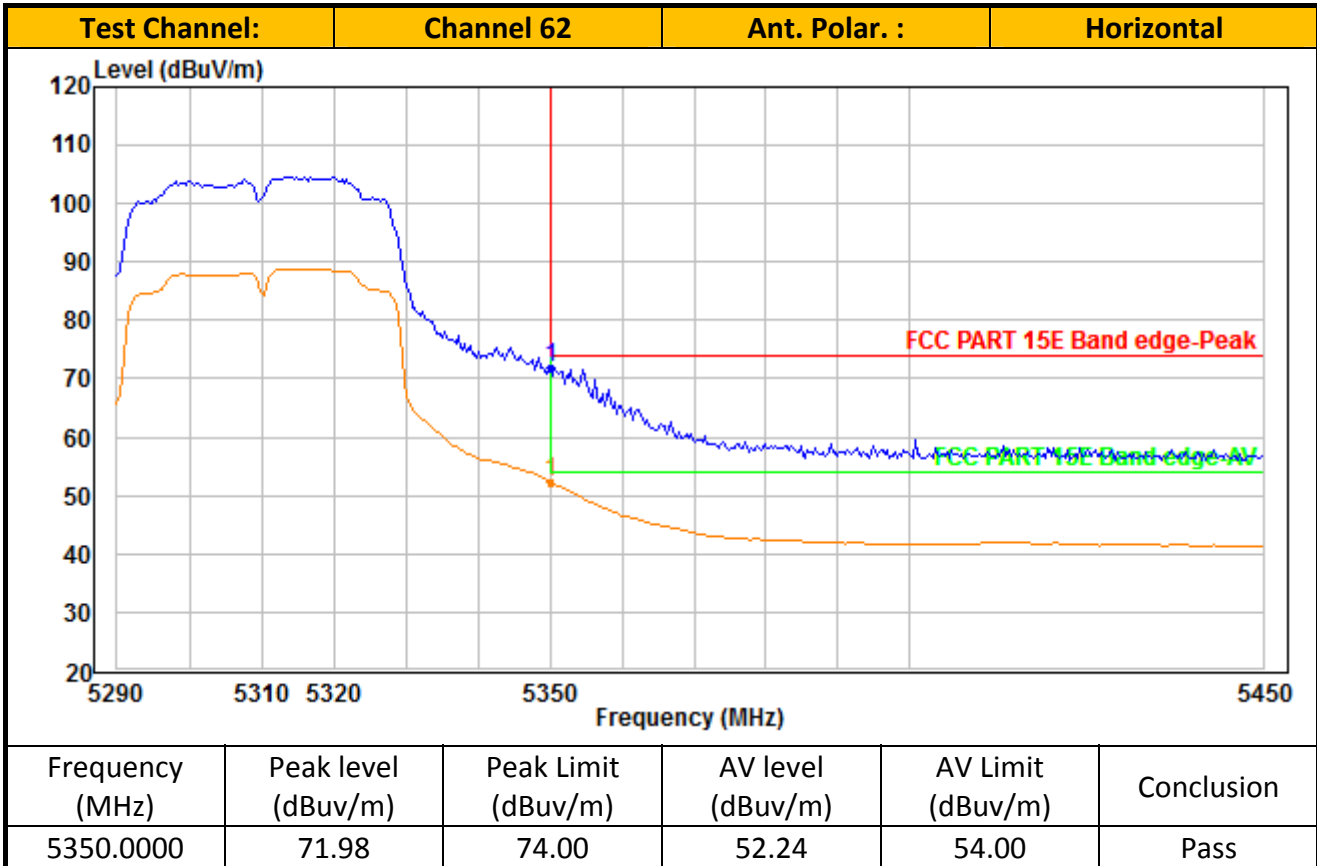

TEST REPORT

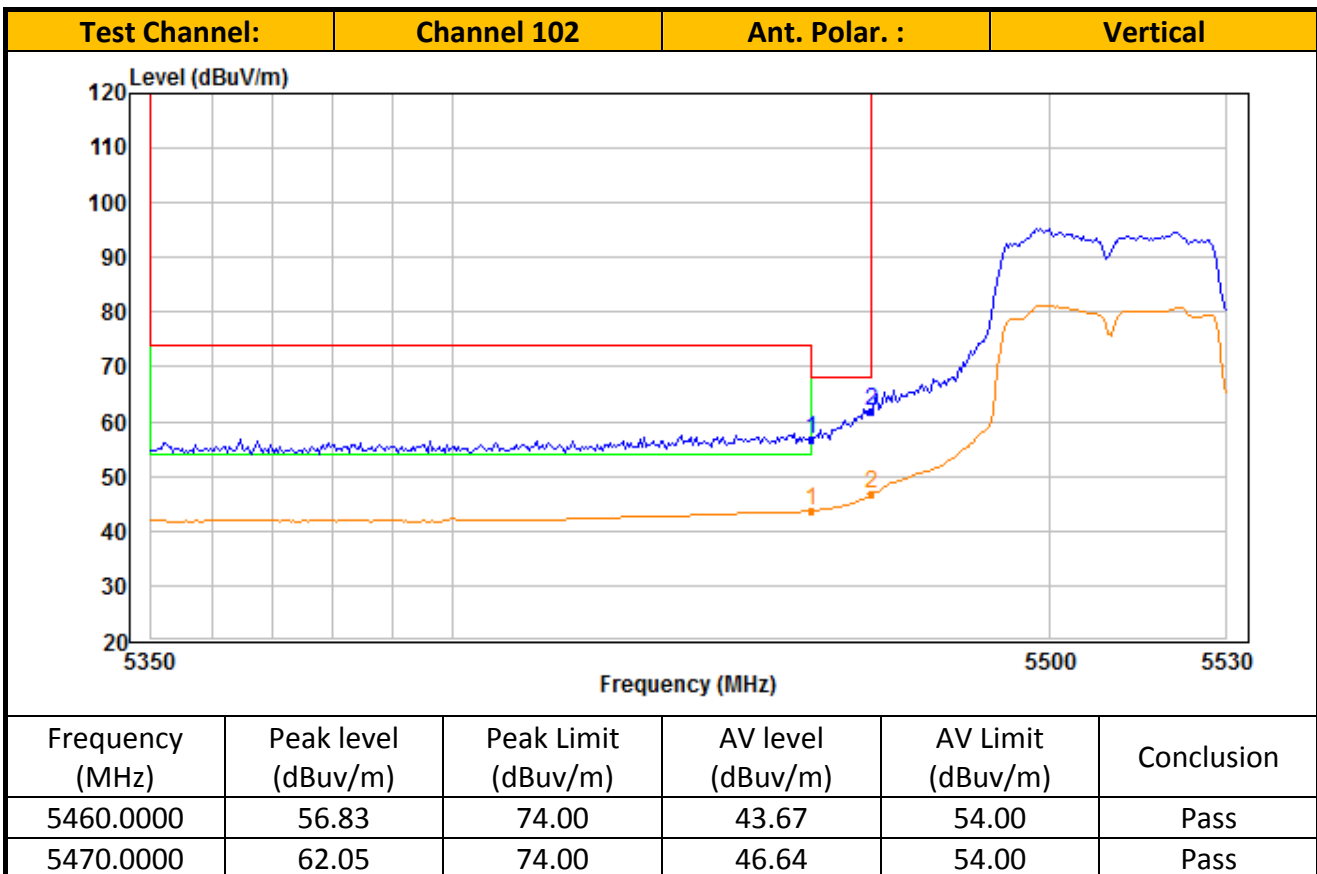
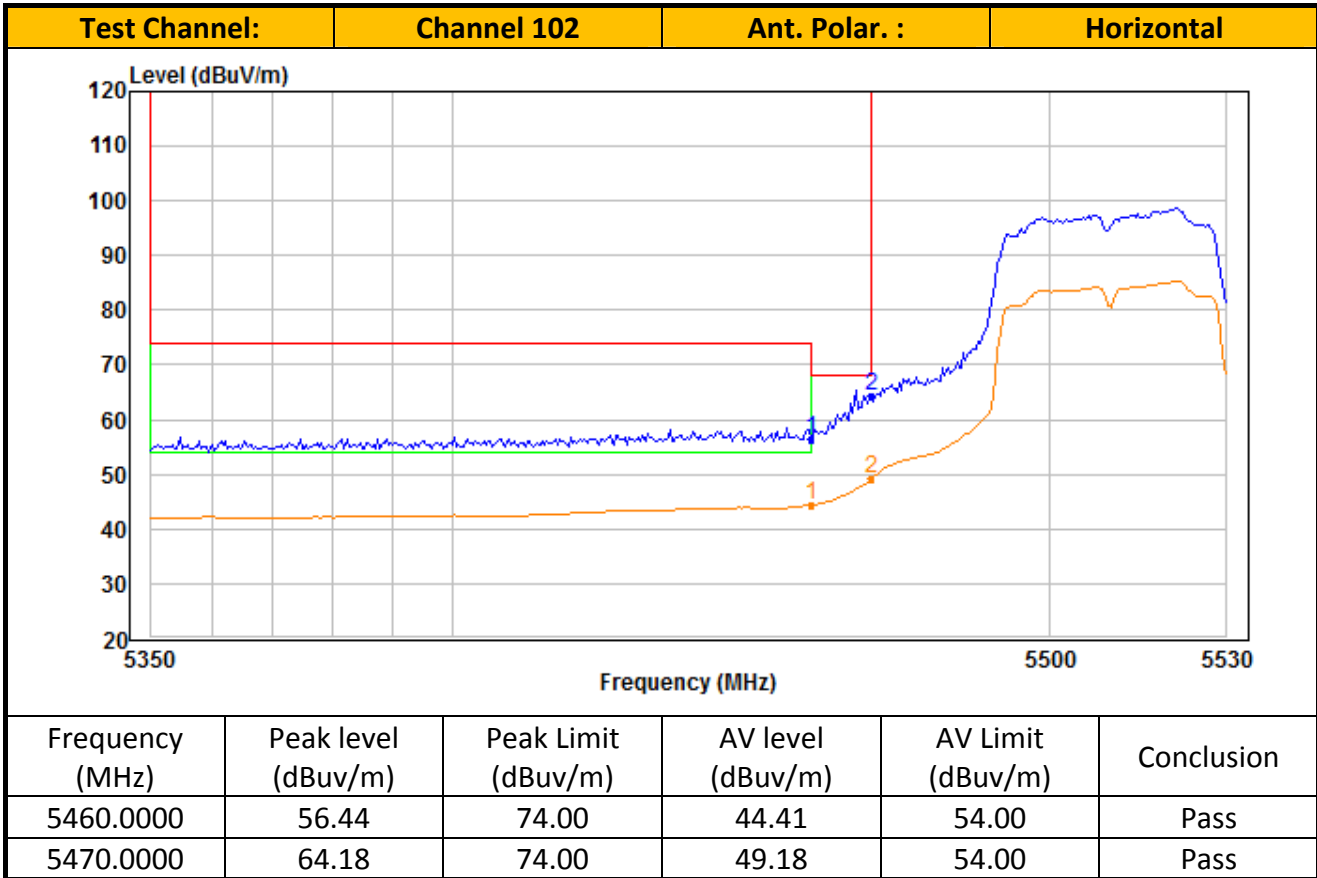

TEST REPORT

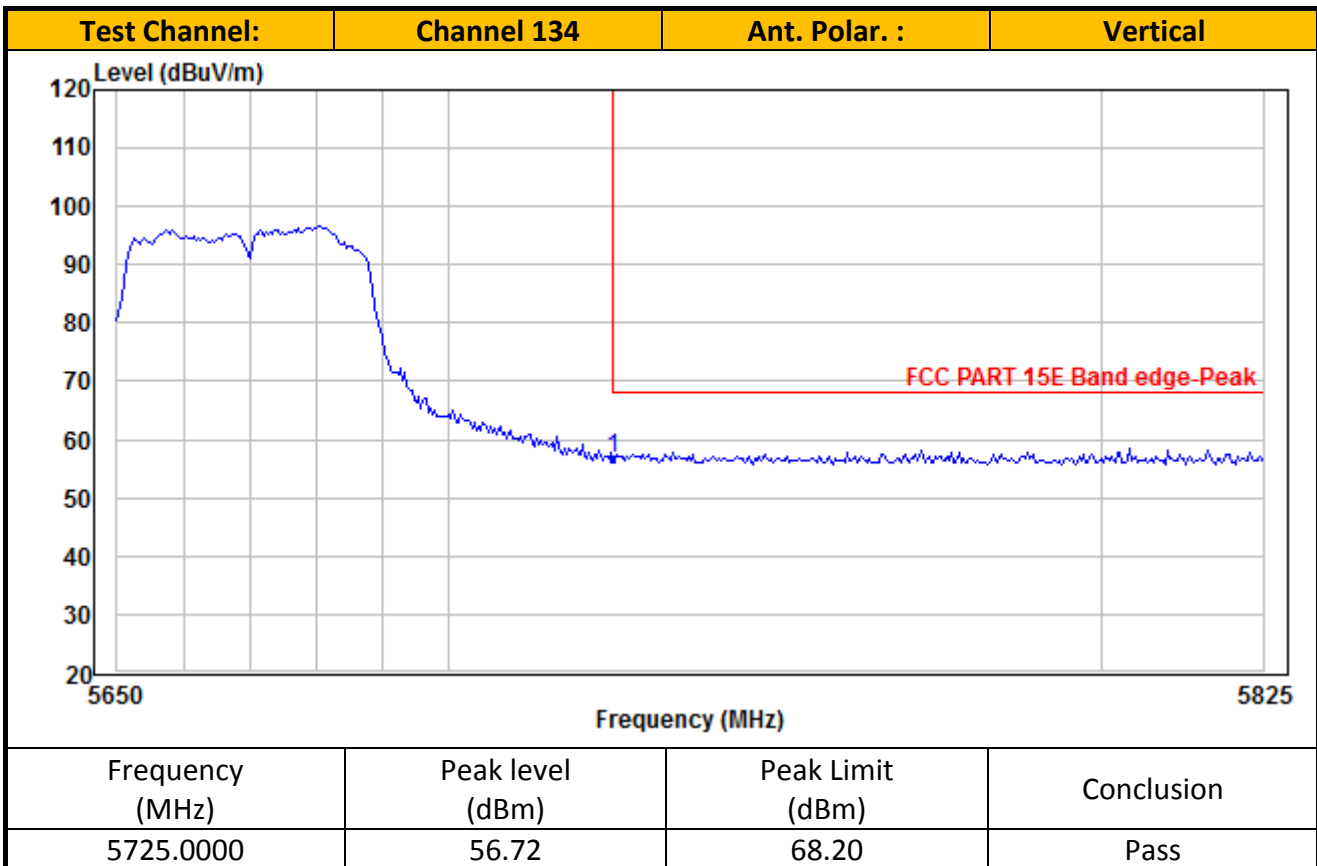
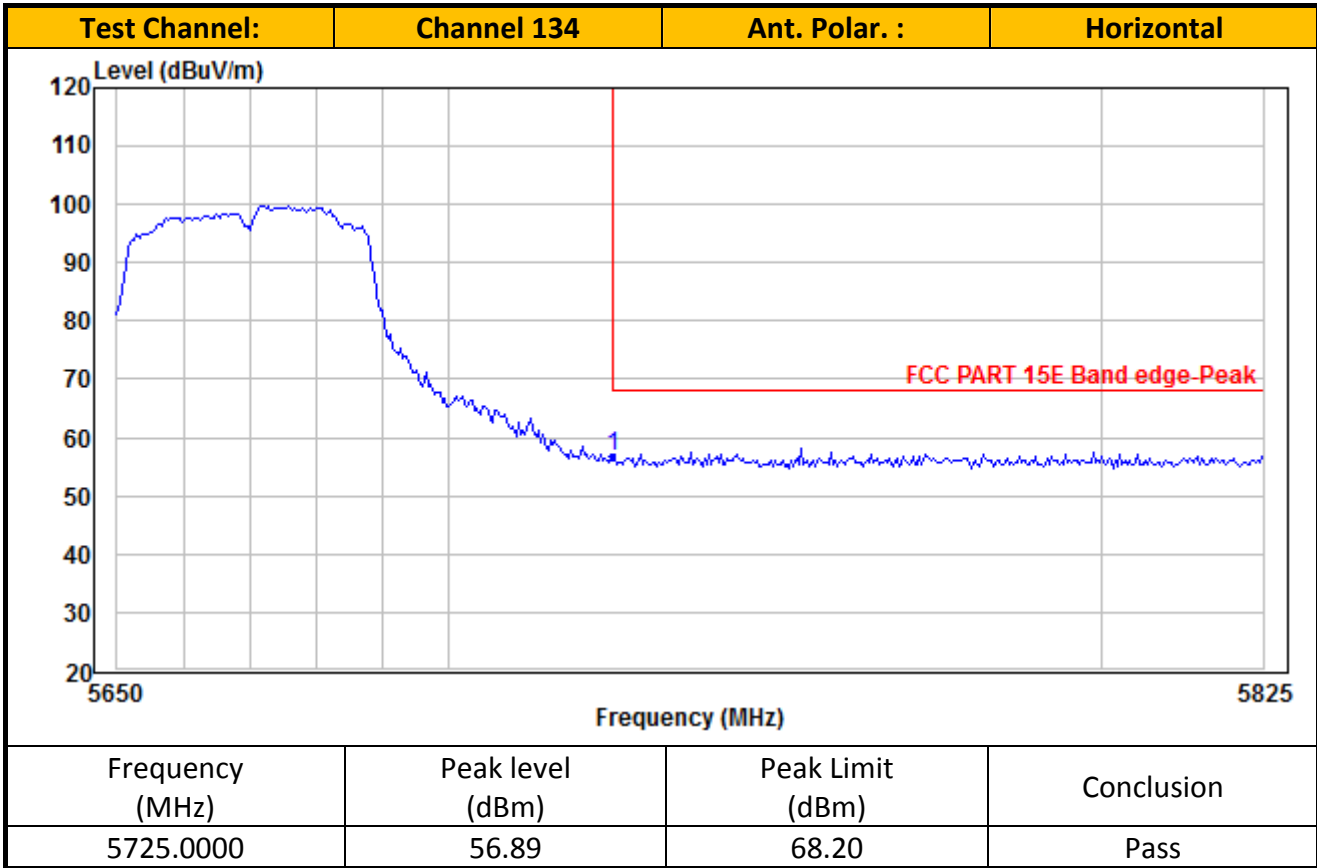

TEST REPORT

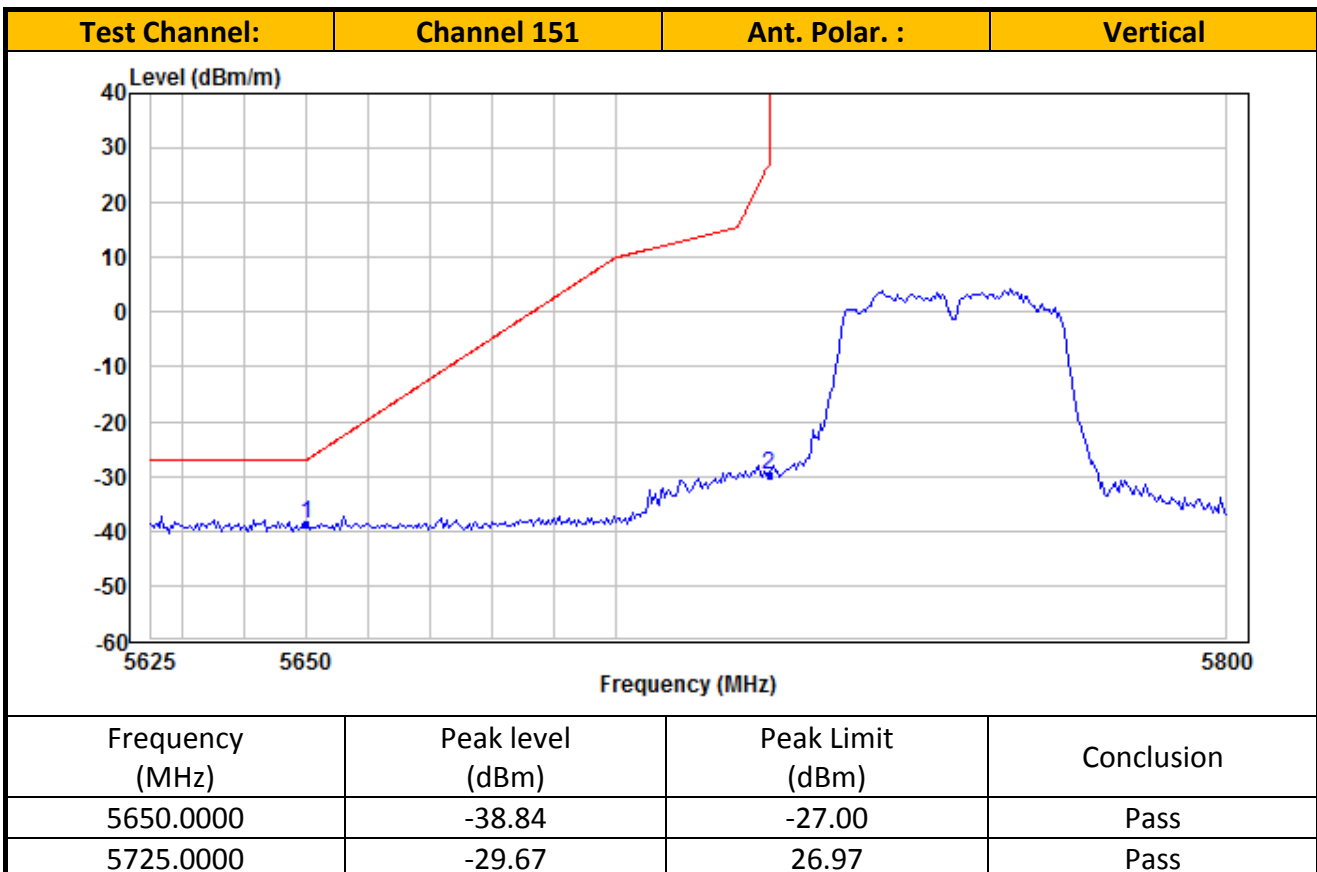
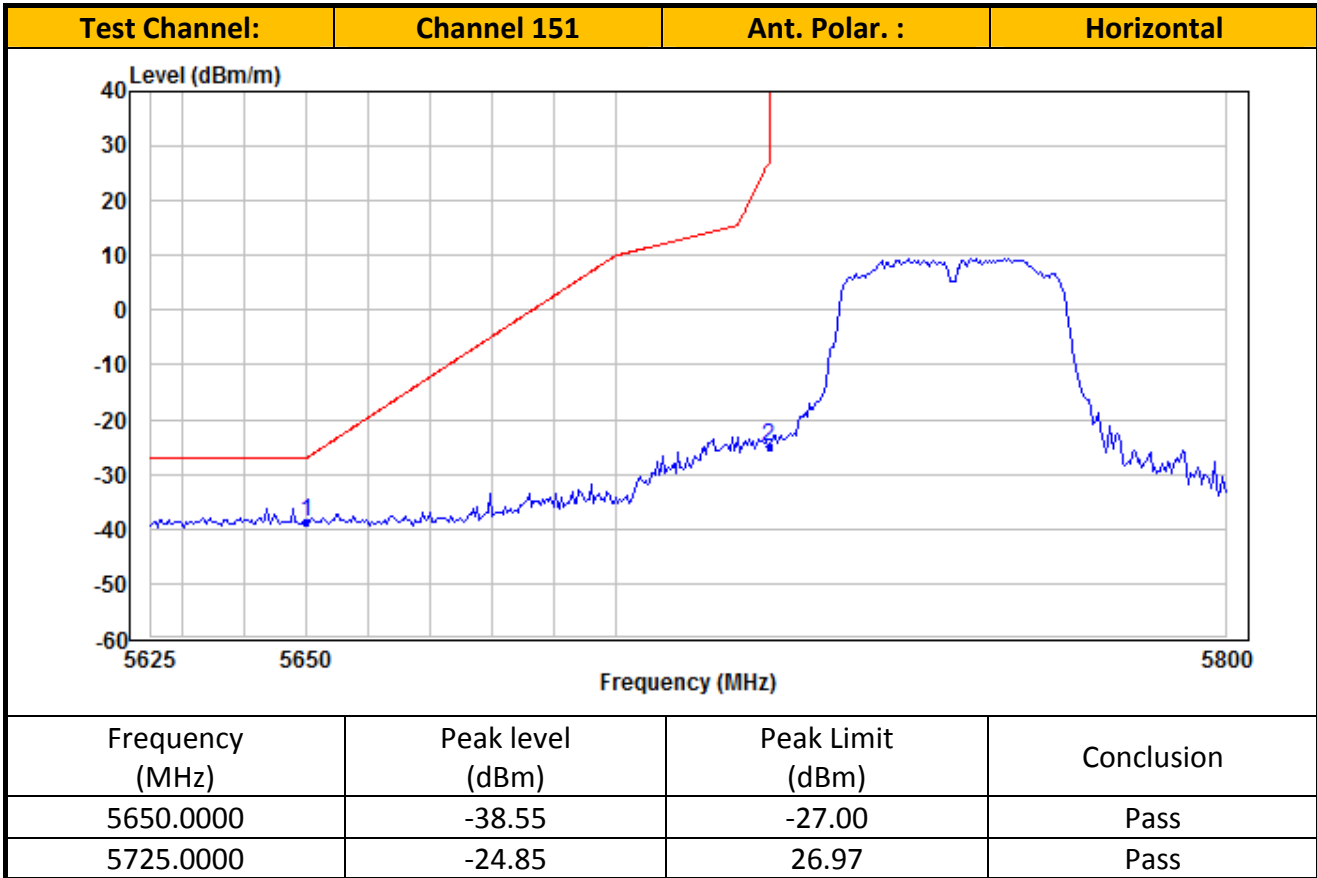

TEST REPORT

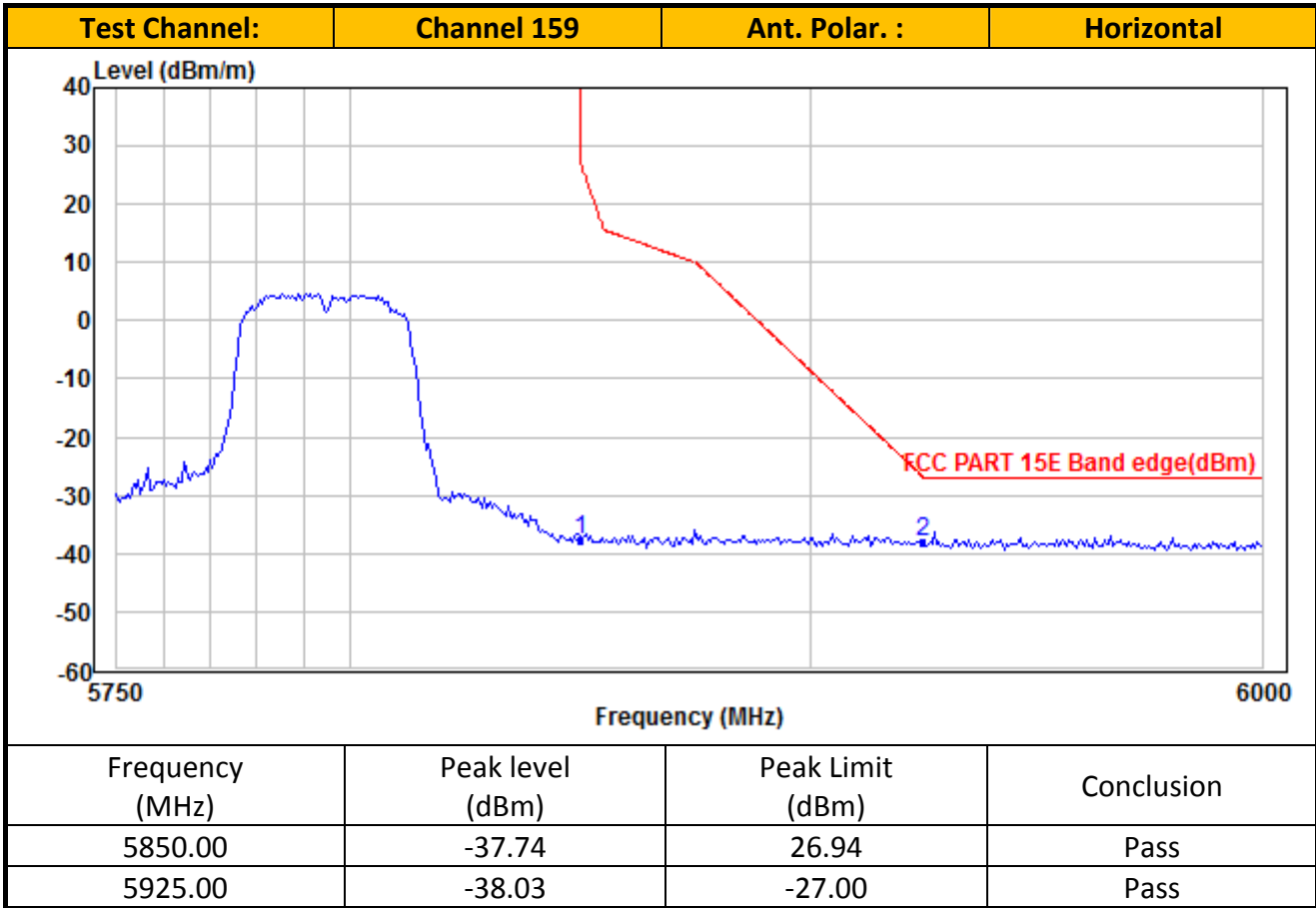

TEST REPORT

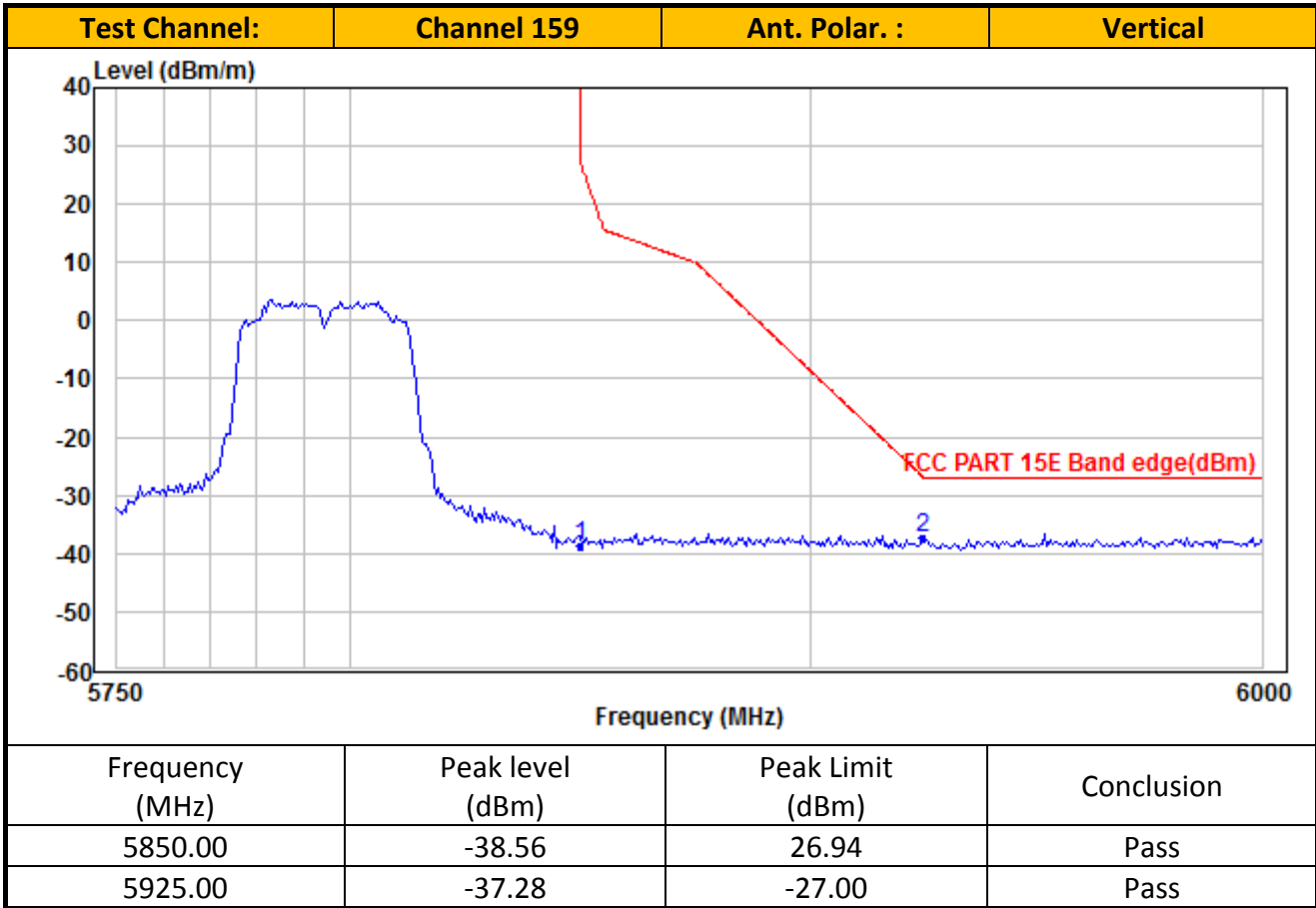

- NOTES:
1. Peak detector is used for the emission measurement.
 2. Average detector is used for the average data of emission measurement
 3. All measurements were made at 3 meters. Radiated emissions not detected at the 3-meter distance were measured at 0.3-meter and an inverse proportional extrapolation was performed to compare the signal level to the 3-meter limit. No other radiated emissions than those reported were detected at a test distance of 0.3-meter.
 4. Value in the margin column shows emission below limit.
 5. Horn antenna is used for the emission over 1000MHz.
 6. Emission (the row indicated by ***bold italic***) within the restricted band meets the requirement of FCC Part 15 Section 15.205.
 7. For the measurement of radiated emission, summation method was used which numerical integrating (in terms of linear power) over the transmitter occupied bandwidth.
 8. For the linear power measurement, data in 1MHz spacing was collected by spectrum analyzer with 1MHz resolution bandwidth.

TEST REPORT

Ant. 1_ IEEE 802.11 ac (20MHz) (MCS0)

Radiated Emission Test Data (Above 1GHz):

IEEE 802.11 ac-VHT20_Channel 36

No.	Frequency (MHz)	Reading (dBuV/m)	Correction factor (dB)	Result (dBuV/m)	Limit (dBuV/m)	Margin (dB)	Detector	Antenna Polaxis
1	10360.00	38.44	11.11	49.55	74.00	24.45	Peak	Horizontal
2	10360.00	26.77	11.11	37.88	54.00	16.12	Average	Horizontal
3	15540.00	48.10	10.76	58.86	74.00	15.14	Peak	Horizontal
4	15540.00	30.18	10.76	40.94	54.00	13.06	Average	Horizontal
5	10360.00	38.14	9.39	47.53	74.00	26.47	Peak	Vertical
6	10360.00	26.03	9.39	35.42	54.00	18.58	Average	Vertical
7	15540.00	48.55	11.59	60.14	74.00	13.86	Peak	Vertical
8	15540.00	31.56	11.59	43.15	54.00	10.85	Average	Vertical

IEEE 802.11ac-VHT20_Channel 44

No.	Frequency (MHz)	Reading (dBuV/m)	Correction factor (dB)	Result (dBuV/m)	Limit (dBuV/m)	Margin (dB)	Detector	Antenna Polaxis
1	10440.00	39.65	11.31	50.96	74.00	23.04	Peak	Horizontal
2	10440.00	27.73	11.31	39.04	54.00	14.96	Average	Horizontal
3	15660.00	42.69	11.00	53.69	74.00	20.31	Peak	Horizontal
4	15660.00	26.72	11.00	37.72	54.00	16.28	Average	Horizontal
5	10440.00	38.70	9.43	48.13	74.00	25.87	Peak	Vertical
6	10440.00	26.98	9.43	36.41	54.00	17.59	Average	Vertical
7	15660.00	39.31	11.93	51.24	74.00	22.76	Peak	Vertical
8	15660.00	26.31	11.93	38.24	54.00	15.76	Average	Vertical

IEEE 802.11ac-VHT20_Channel 48

No.	Frequency (MHz)	Reading (dBuV/m)	Correction factor (dB)	Result (dBuV/m)	Limit (dBuV/m)	Margin (dB)	Detector	Antenna Polaxis
1	10480.00	39.07	11.41	50.48	74.00	23.52	Peak	Horizontal
2	10480.00	27.33	11.41	38.74	54.00	15.26	Average	Horizontal
3	15720.00	45.09	11.08	56.17	74.00	17.83	Peak	Horizontal
4	15720.00	28.35	11.08	39.43	54.00	14.57	Average	Horizontal
5	10480.00	37.82	9.45	47.27	74.00	26.73	Peak	Vertical
6	10480.00	26.02	9.45	35.47	54.00	18.53	Average	Vertical
7	15720.00	44.90	12.05	56.95	74.00	17.05	Peak	Vertical
8	15720.00	27.73	12.05	39.78	54.00	14.22	Average	Vertical

TEST REPORT

IEEE 802.11ac-VHT20_Channel 52

No.	Frequency (MHz)	Reading (dBuV/m)	Correction factor (dB)	Result (dBuV/m)	Limit (dBuV/m)	Margin (dB)	Detector	Antenna Polaxis
1	10520.00	39.85	11.42	51.27	74.00	22.73	Peak	Horizontal
2	10520.00	27.32	11.42	38.74	54.00	15.26	Average	Horizontal
3	15780.00	44.10	11.16	55.26	74.00	18.74	Peak	Horizontal
4	15780.00	26.81	11.16	37.97	54.00	16.03	Average	Horizontal
5	10520.00	38.49	9.43	47.92	74.00	26.08	Peak	Vertical
6	10520.00	26.18	9.43	35.61	54.00	18.39	Average	Vertical
7	15780.00	42.12	12.19	54.31	74.00	19.69	Peak	Vertical
8	15780.00	26.38	12.19	38.57	54.00	15.43	Average	Vertical

IEEE 802.11ac-VHT20_Channel 60

No.	Frequency (MHz)	Reading (dBuV/m)	Correction factor (dB)	Result (dBuV/m)	Limit (dBuV/m)	Margin (dB)	Detector	Antenna Polaxis
1	10600.00	39.32	11.33	50.65	74.00	23.35	Peak	Horizontal
2	10600.00	27.39	11.33	38.72	54.00	15.28	Average	Horizontal
3	15900.00	43.83	11.33	55.16	74.00	18.84	Peak	Horizontal
4	15900.00	26.12	11.33	37.45	54.00	16.55	Average	Horizontal
5	10600.00	37.95	9.37	47.32	74.00	26.68	Peak	Vertical
6	10600.00	26.35	9.37	35.72	54.00	18.28	Average	Vertical
7	15900.00	44.15	12.45	56.60	74.00	17.40	Peak	Vertical
8	15900.00	25.63	12.45	38.08	54.00	15.92	Average	Vertical

IEEE 802.11ac-VHT20_Channel 64

No.	Frequency (MHz)	Reading (dBuV/m)	Correction factor (dB)	Result (dBuV/m)	Limit (dBuV/m)	Margin (dB)	Detector	Antenna Polaxis
1	10640.00	38.87	11.29	50.16	74.00	23.84	Peak	Horizontal
2	10640.00	27.61	11.29	38.90	54.00	15.10	Average	Horizontal
3	15960.00	44.13	11.49	55.62	74.00	18.38	Peak	Horizontal
4	15960.00	27.05	11.49	38.54	54.00	15.46	Average	Horizontal
5	10640.00	39.17	9.34	48.51	74.00	25.49	Peak	Vertical
6	10640.00	26.66	9.34	36.00	54.00	18.00	Average	Vertical
7	15960.00	46.02	12.66	58.68	74.00	15.32	Peak	Vertical
8	15960.00	26.70	12.66	39.36	54.00	14.64	Average	Vertical

TEST REPORT

IEEE 802.11ac-VHT20_Channel 100

No.	Frequency (MHz)	Reading (dBuV/m)	Correction factor (dB)	Result (dBuV/m)	Limit (dBuV/m)	Margin (dB)	Detector	Antenna Polaxis
1	11000.00	40.04	10.30	50.34	74.00	23.66	Peak	Horizontal
2	11000.00	28.40	10.30	38.70	54.00	15.30	Average	Horizontal
3	16500.00	43.56	13.35	56.91	74.00	17.09	Peak	Horizontal
4	16500.00	26.16	13.35	39.51	54.00	14.49	Average	Horizontal
5	11000.00	40.14	8.50	48.64	74.00	25.36	Peak	Vertical
6	11000.00	27.95	8.50	36.45	54.00	17.55	Average	Vertical
7	16500.00	37.18	13.45	50.63	74.00	23.37	Peak	Vertical
8	16500.00	24.69	13.45	38.14	54.00	15.86	Average	Vertical

IEEE 802.11ac-VHT20_Channel 116

No.	Frequency (MHz)	Reading (dBuV/m)	Correction factor (dB)	Result (dBuV/m)	Limit (dBuV/m)	Margin (dB)	Detector	Antenna Polaxis
1	11160.00	38.91	9.97	48.88	74.00	25.12	Peak	Horizontal
2	11160.00	27.50	9.97	37.47	54.00	16.53	Average	Horizontal
3	16740.00	39.22	13.24	52.46	74.00	21.54	Peak	Horizontal
4	16740.00	26.87	13.24	40.11	54.00	13.89	Average	Horizontal
5	11160.00	39.59	8.27	47.86	74.00	26.14	Peak	Vertical
6	11160.00	27.10	8.27	35.37	54.00	18.63	Average	Vertical
7	16740.00	38.67	13.01	51.68	74.00	22.32	Peak	Vertical
8	16740.00	25.35	13.01	38.36	54.00	15.64	Average	Vertical

IEEE 802.11ac-VHT20_Channel 140

No.	Frequency (MHz)	Reading (dBuV/m)	Correction factor (dB)	Result (dBuV/m)	Limit (dBuV/m)	Margin (dB)	Detector	Antenna Polaxis
1	11400.00	40.79	9.86	50.65	74.00	23.35	Peak	Horizontal
2	11400.00	28.79	9.86	38.65	54.00	15.35	Average	Horizontal
3	17100.00	43.44	13.42	56.86	74.00	17.14	Peak	Horizontal
4	17100.00	26.05	13.42	39.47	54.00	14.53	Average	Horizontal
5	11400.00	41.04	8.30	49.34	74.00	24.66	Peak	Vertical
6	11400.00	28.63	8.30	36.93	54.00	17.07	Average	Vertical
7	17100.00	38.80	12.76	51.56	74.00	22.44	Peak	Vertical
8	17100.00	25.35	12.76	38.11	54.00	15.89	Average	Vertical

TEST REPORT

IEEE 802.11ac-VHT20_Channel 149

No.	Frequency (MHz)	Reading (dBuV/m)	Correction factor (dB)	Result (dBuV/m)	Limit (dBuV/m)	Margin (dB)	Detector	Antenna Polaxis
1	11490.00	40.28	9.78	50.06	74.00	23.94	Peak	Horizontal
2	11490.00	28.59	9.78	38.37	54.00	15.63	Average	Horizontal
3	17235.00	46.05	13.98	60.03	74.00	13.97	Peak	Horizontal
4	17235.00	25.32	13.98	39.30	54.00	14.70	Average	Horizontal
5	11490.00	40.89	8.27	49.16	74.00	24.84	Peak	Vertical
6	11490.00	28.47	8.27	36.74	54.00	17.26	Average	Vertical
7	17235.00	38.56	13.24	51.80	74.00	22.20	Peak	Vertical
8	17235.00	25.45	13.24	38.69	54.00	15.31	Average	Vertical

IEEE 802.11ac-VHT20_Channel 157

No.	Frequency (MHz)	Reading (dBuV/m)	Correction factor (dB)	Result (dBuV/m)	Limit (dBuV/m)	Margin (dB)	Detector	Antenna Polaxis
1	11570.00	40.15	9.86	50.01	74.00	23.99	Peak	Horizontal
2	11570.00	28.03	9.86	37.89	54.00	16.11	Average	Horizontal
3	17355.00	45.62	14.49	60.11	74.00	13.89	Peak	Horizontal
4	17355.00	27.23	14.49	41.72	54.00	12.28	Average	Horizontal
5	11570.00	40.07	8.47	48.54	74.00	25.46	Peak	Vertical
6	11570.00	27.95	8.47	36.42	54.00	17.58	Average	Vertical
7	17355.00	38.11	13.68	51.79	74.00	22.21	Peak	Vertical
8	17355.00	26.48	13.68	40.16	54.00	13.84	Average	Vertical

IEEE 802.11ac-VHT20_Channel 165

No.	Frequency (MHz)	Reading (dBuV/m)	Correction factor (dB)	Result (dBuV/m)	Limit (dBuV/m)	Margin (dB)	Detector	Antenna Polaxis
1	11650.00	40.60	9.95	50.55	74.00	23.45	Peak	Horizontal
2	11650.00	28.03	9.95	37.98	54.00	16.02	Average	Horizontal
3	17475.00	47.75	14.89	62.64	74.00	11.36	Peak	Horizontal
4	17475.00	27.20	14.89	42.09	54.00	11.91	Average	Horizontal
5	11650.00	41.03	8.69	49.72	74.00	24.28	Peak	Vertical
6	11650.00	27.92	8.69	36.61	54.00	17.39	Average	Vertical
7	17475.00	43.26	14.00	57.26	74.00	16.74	Peak	Vertical
8	17475.00	26.60	14.00	40.60	54.00	13.40	Average	Vertical

TEST REPORT

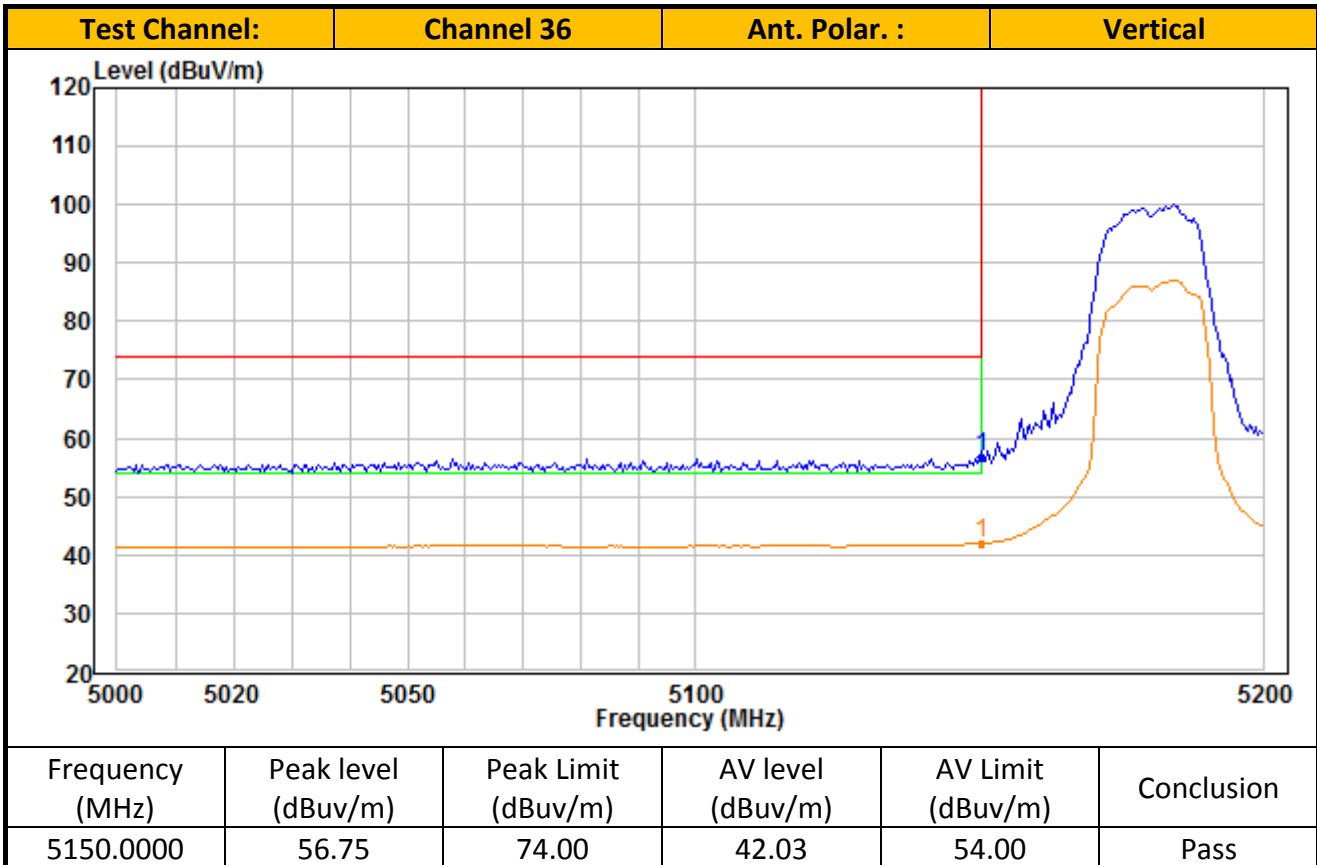
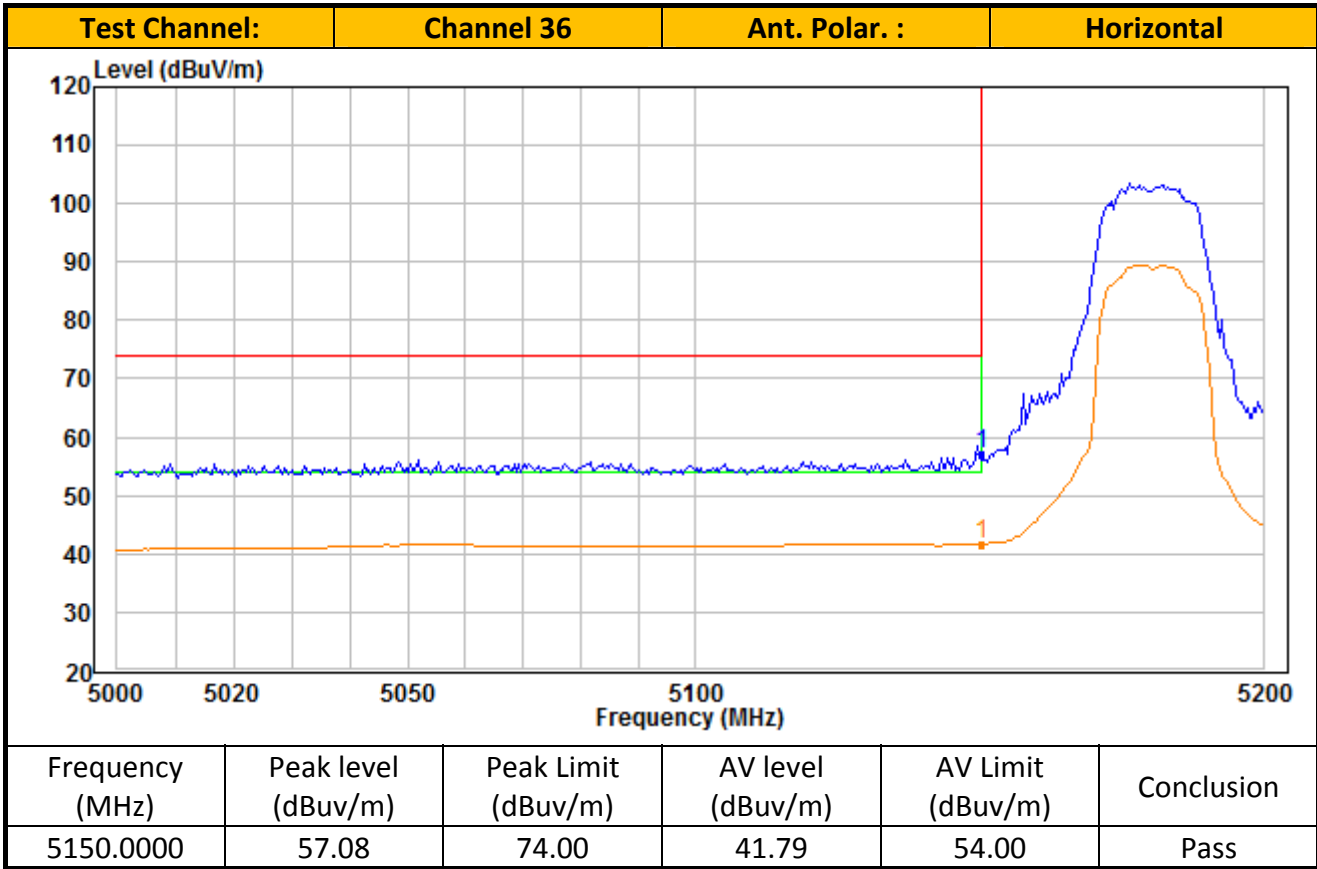

TEST REPORT

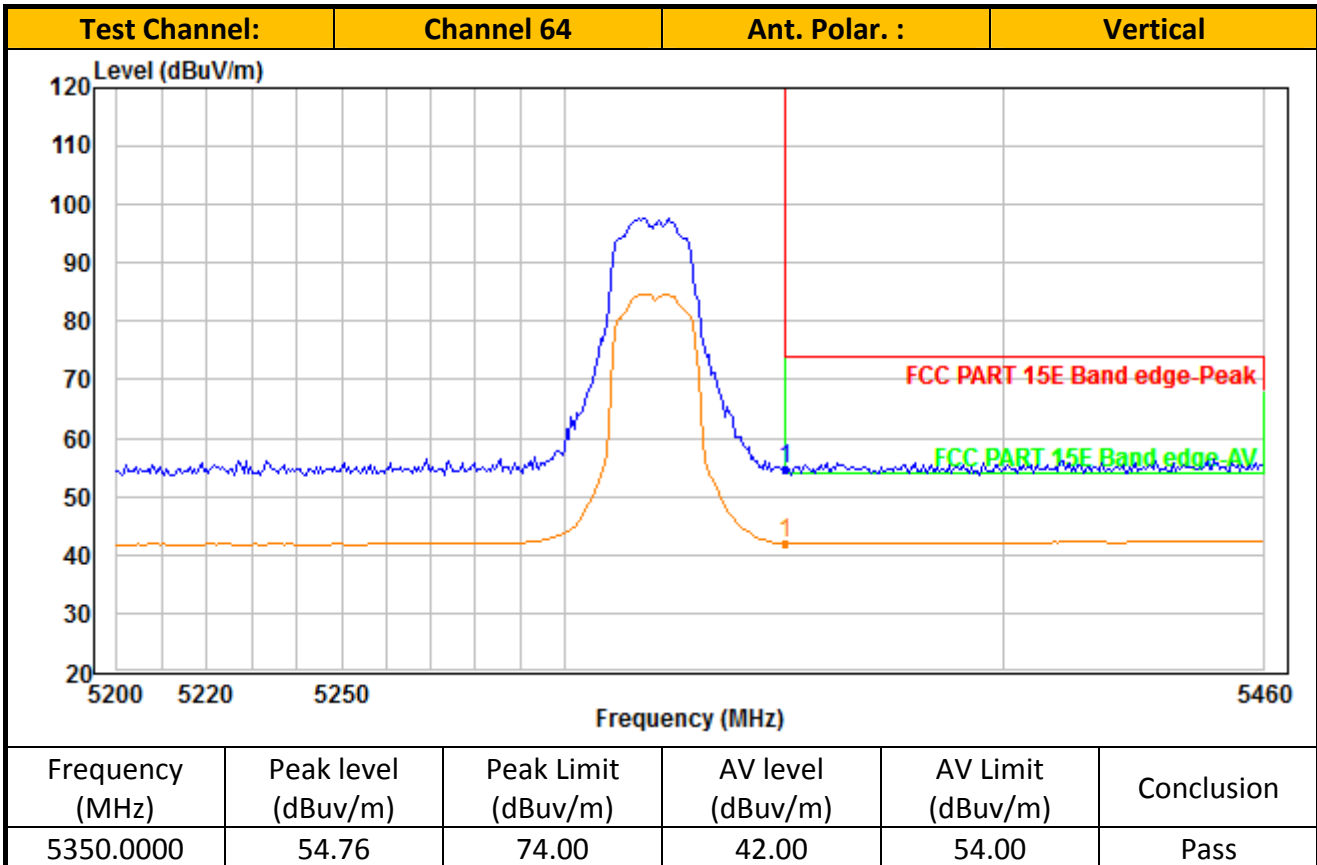
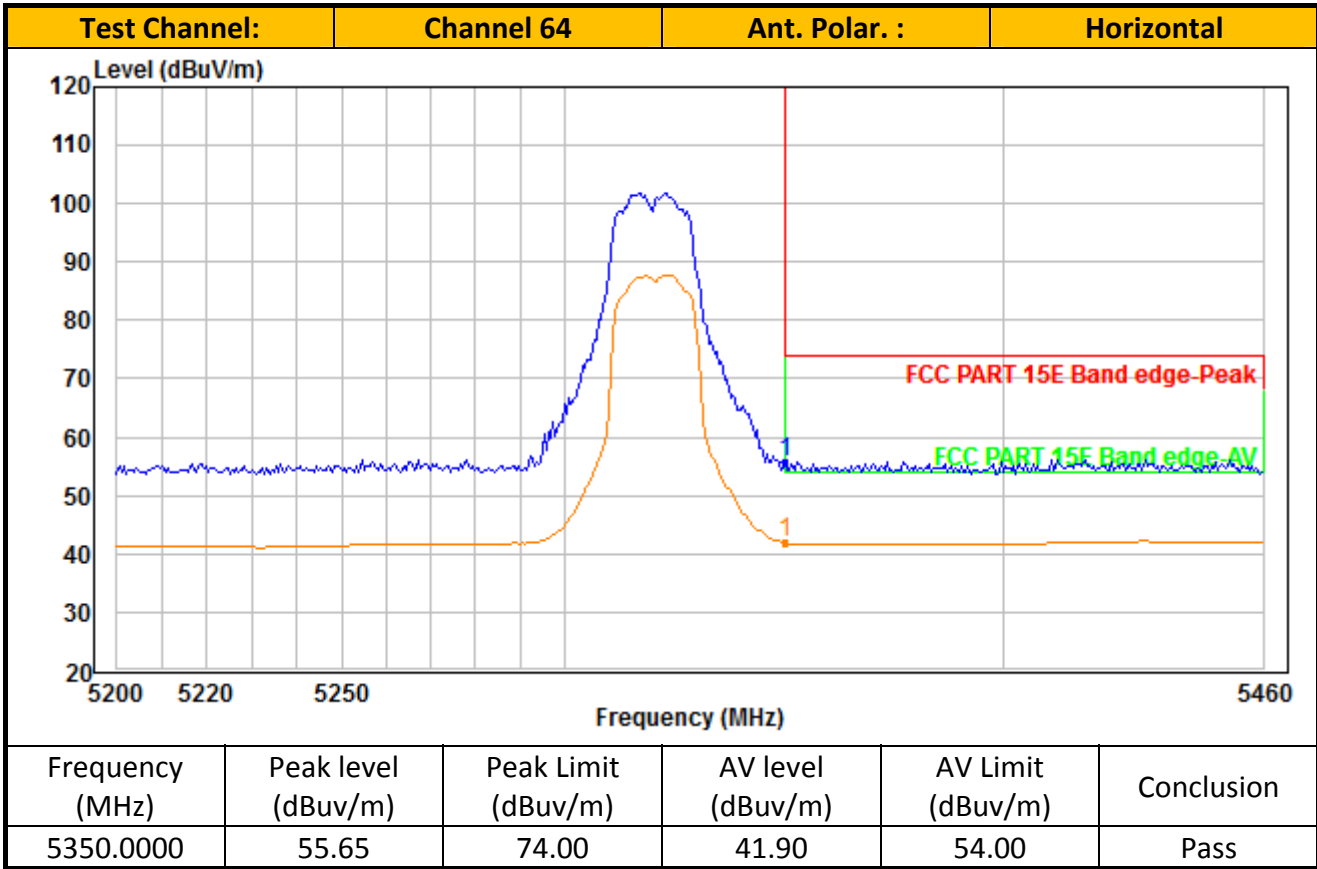

TEST REPORT

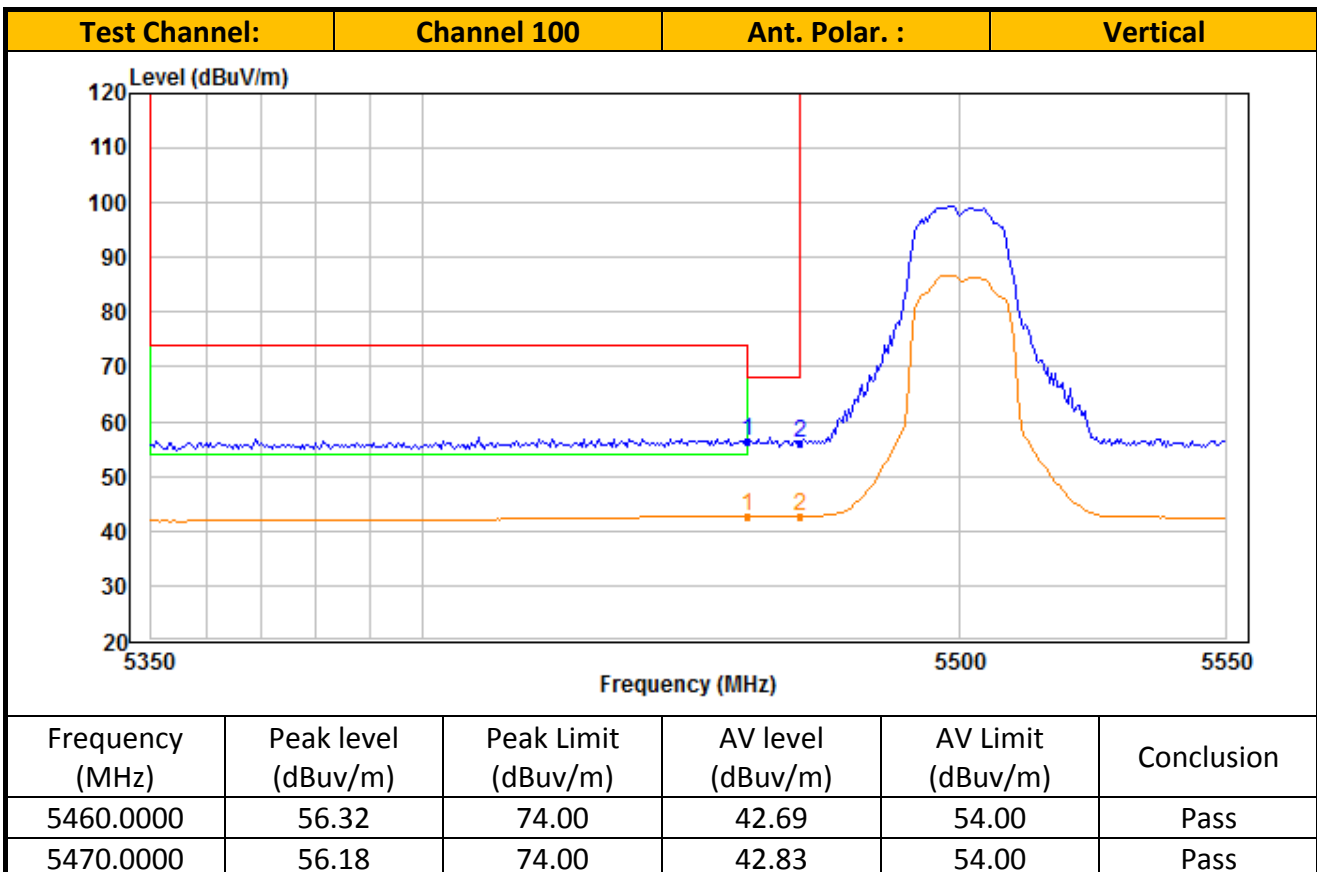
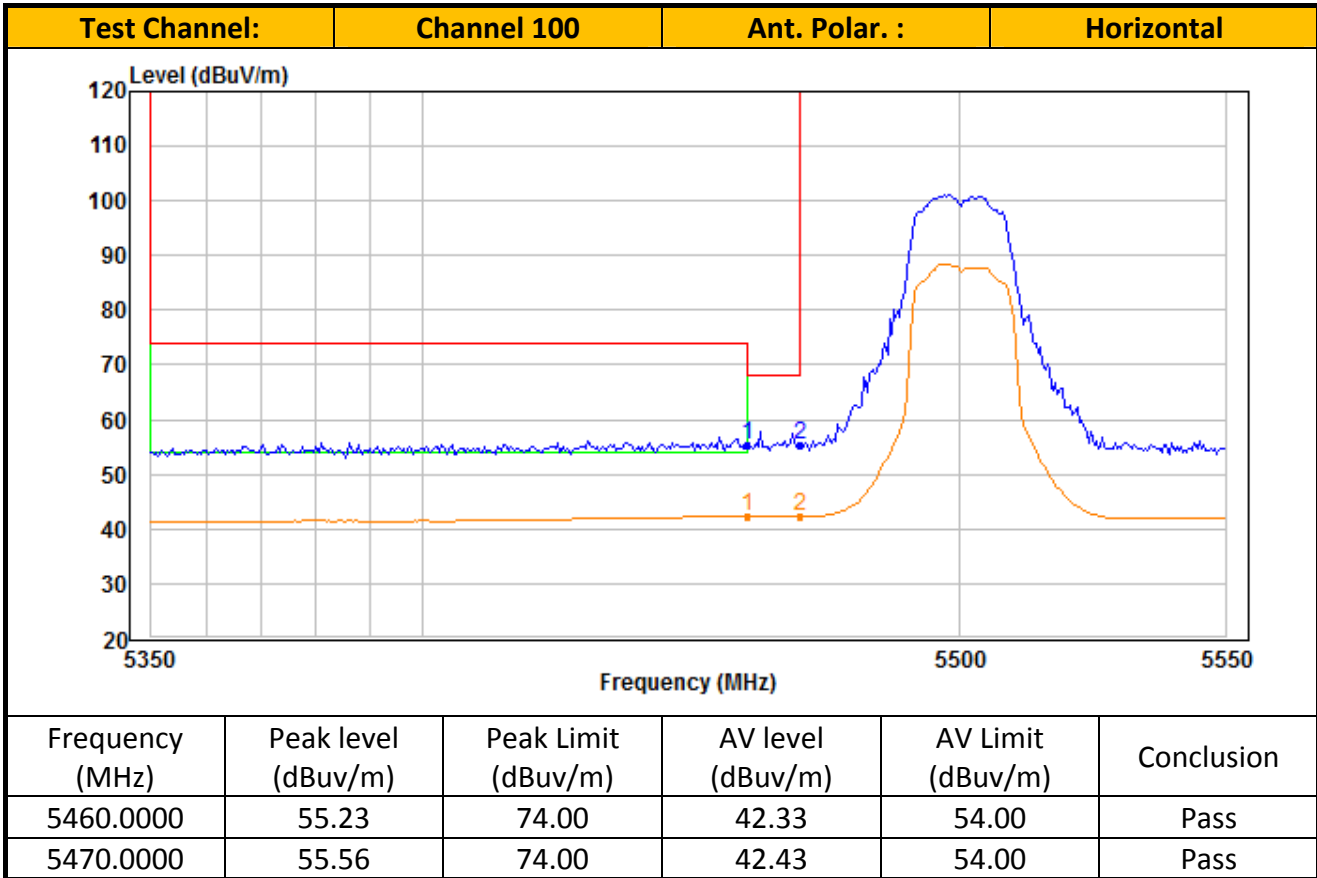

TEST REPORT

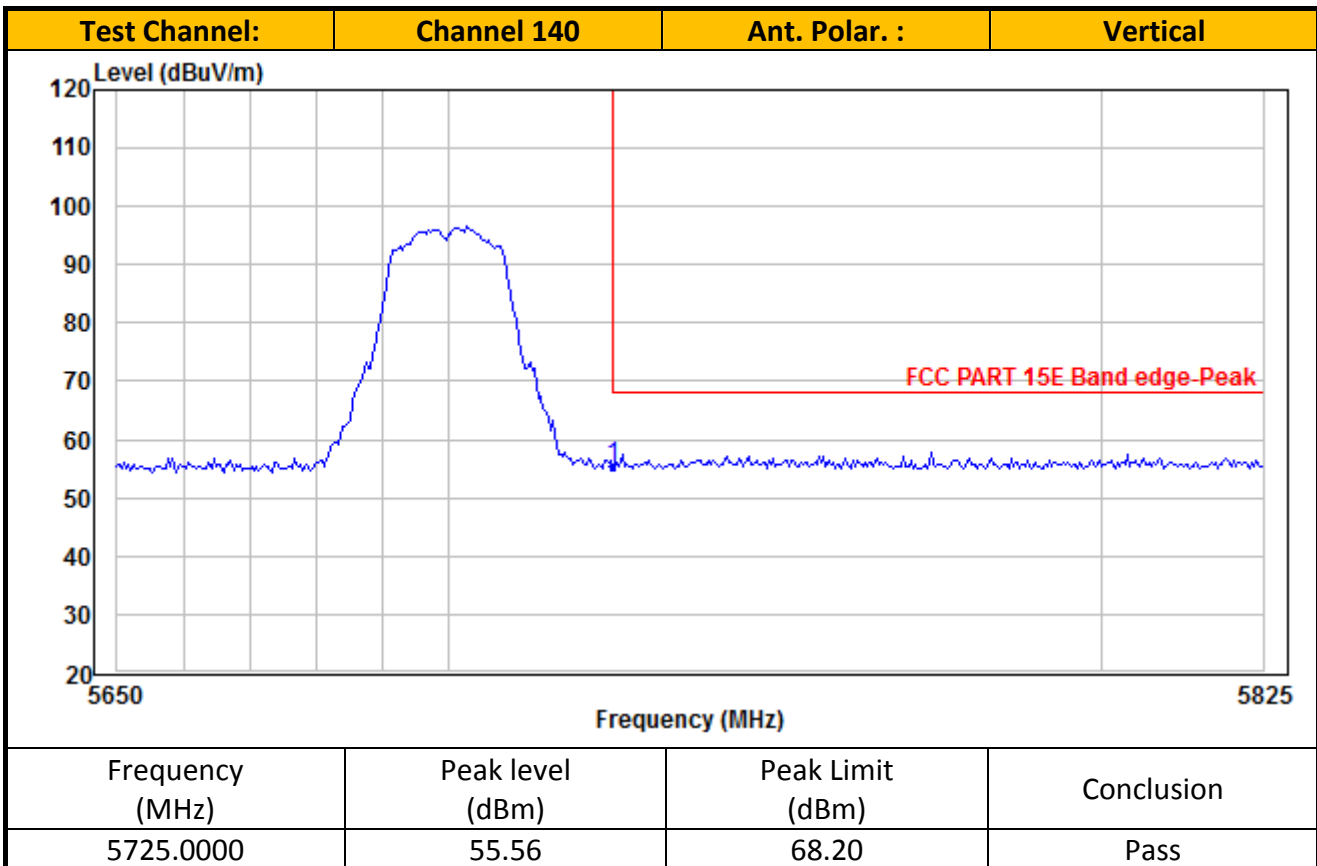
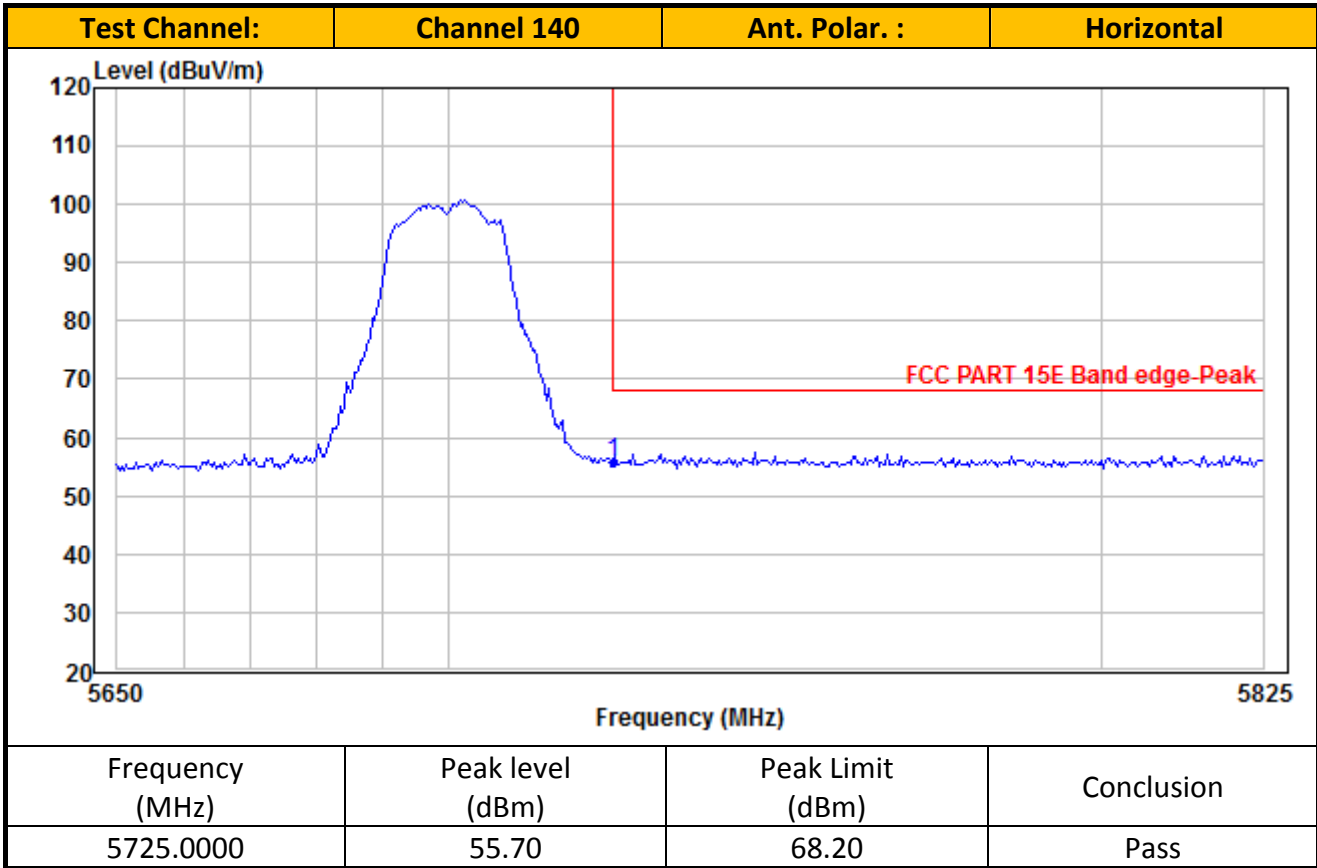

TEST REPORT

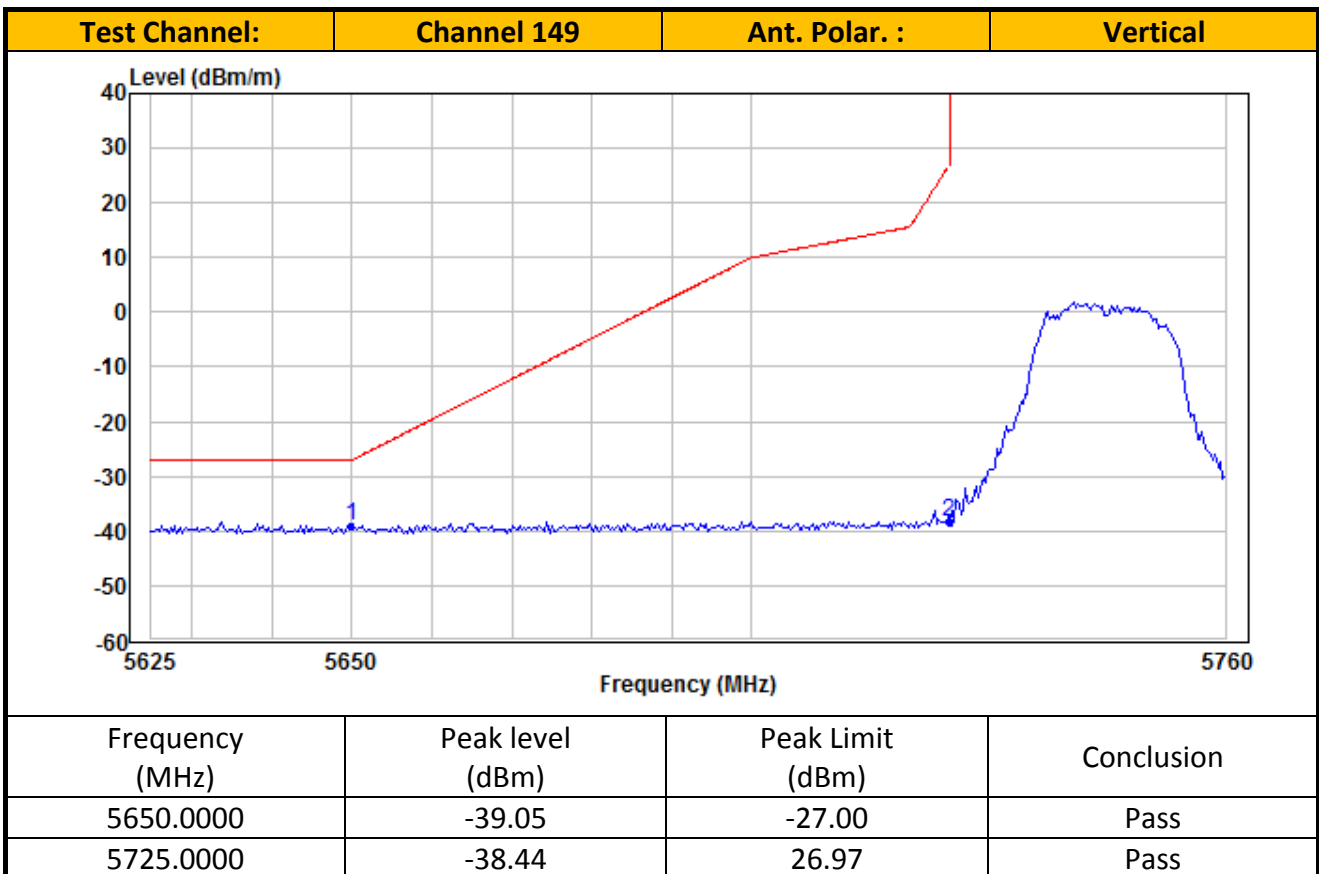
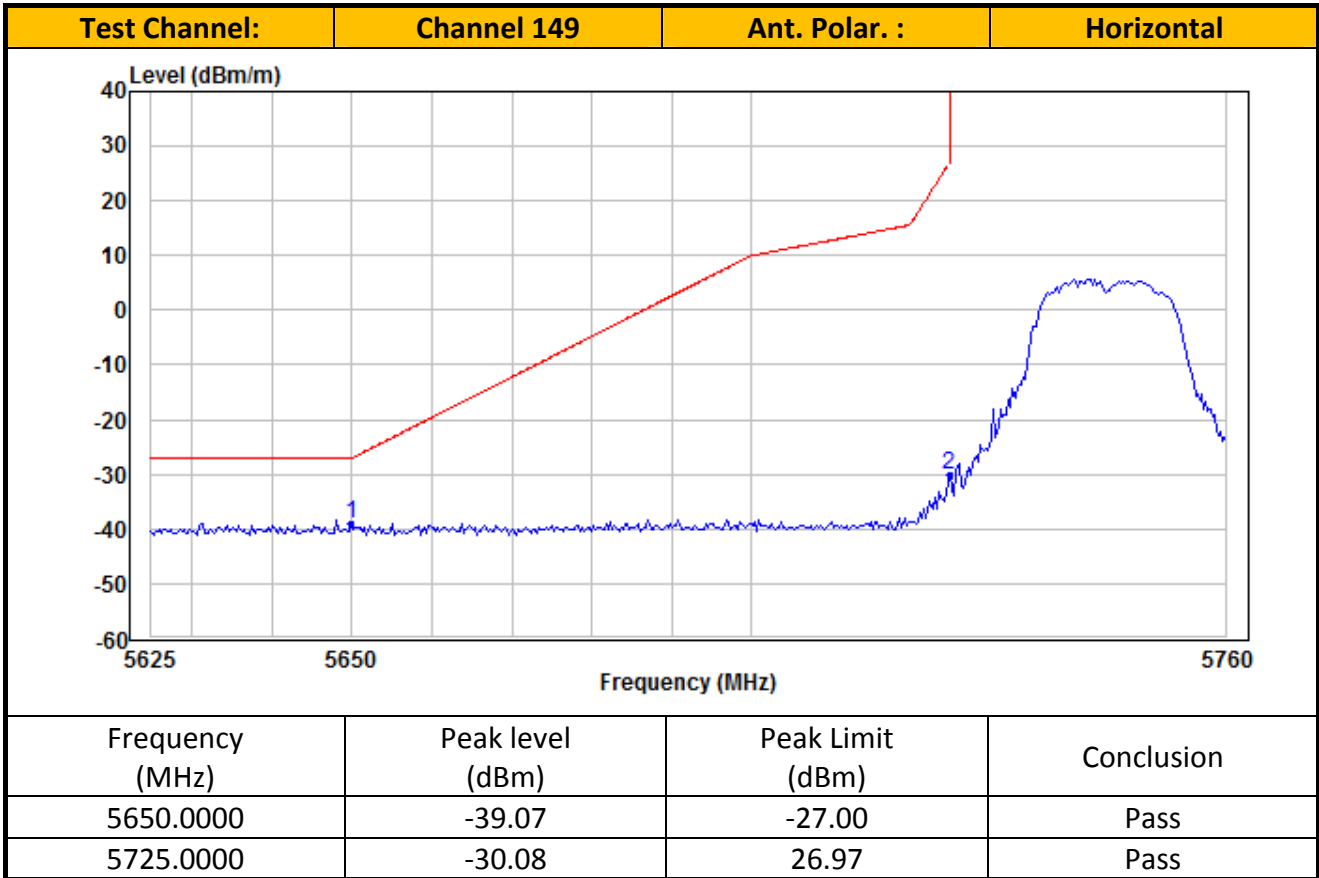

TEST REPORT

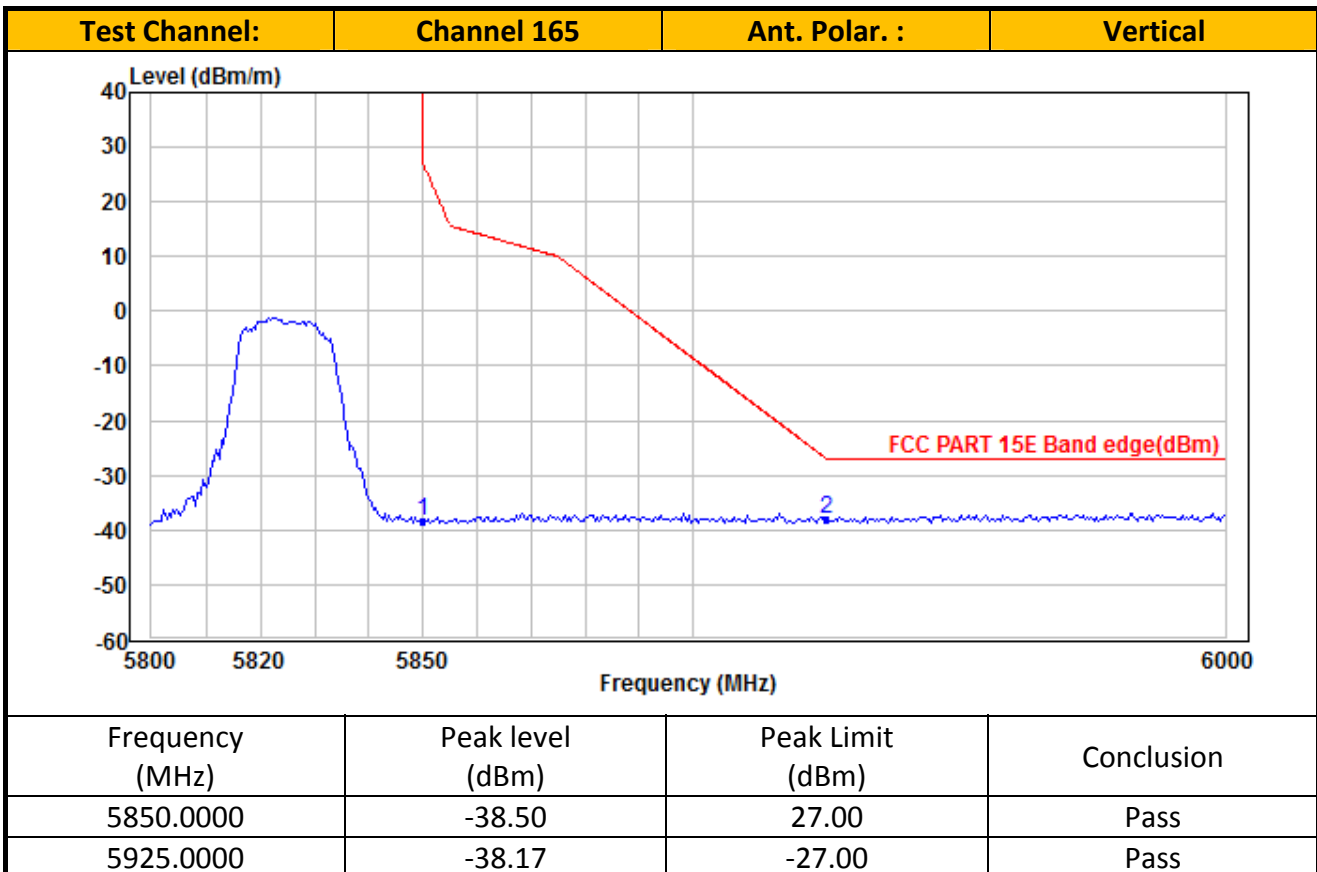
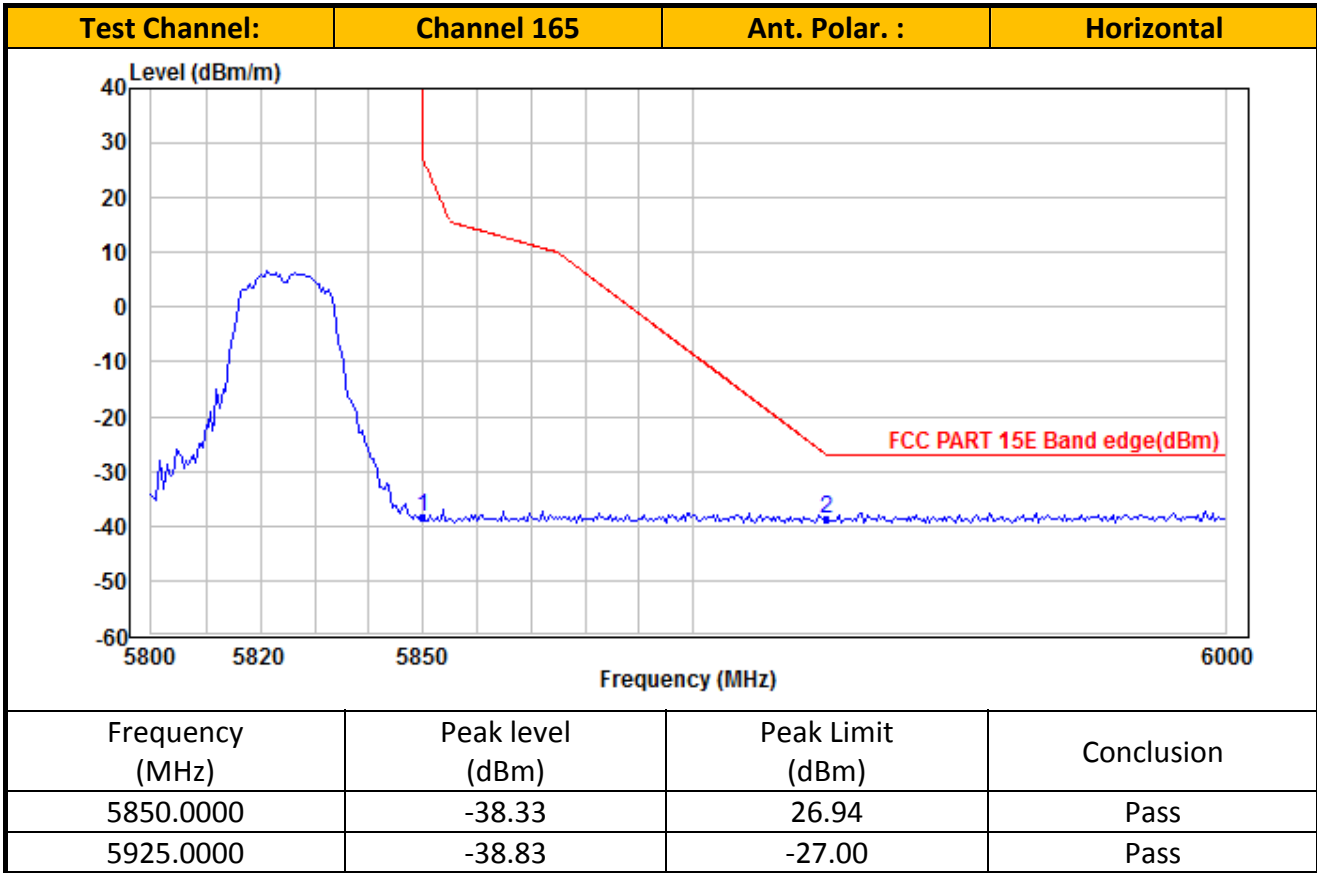

TEST REPORT

Ant. 2_ IEEE 802.11ac (20MHz) (MCS0)

Radiated Emission Test Data (Above 1GHz):

IEEE 802.11ac-VHT20_Channel 36

No.	Frequency (MHz)	Reading (dBuV/m)	Correction factor (dB)	Result (dBuV/m)	Limit (dBuV/m)	Margin (dB)	Detector	Antenna Polaxis
1	10360.00	40.63	11.11	51.74	74.00	22.26	Peak	Horizontal
2	10360.00	28.89	11.11	40.00	54.00	14.00	Average	Horizontal
3	15540.00	45.72	10.76	56.48	74.00	17.52	Peak	Horizontal
4	15540.00	27.57	10.76	38.33	54.00	15.67	Average	Horizontal
5	10360.00	38.47	9.39	47.86	74.00	26.14	Peak	Vertical
6	10360.00	26.29	9.39	35.68	54.00	18.32	Average	Vertical
7	15540.00	45.01	11.59	56.60	74.00	17.40	Peak	Vertical
8	15540.00	26.94	11.59	38.53	54.00	15.47	Average	Vertical

IEEE 802.11ac-VHT20_Channel 44

No.	Frequency (MHz)	Reading (dBuV/m)	Correction factor (dB)	Result (dBuV/m)	Limit (dBuV/m)	Margin (dB)	Detector	Antenna Polaxis
1	10440.00	40.26	11.31	51.57	74.00	22.43	Peak	Horizontal
2	10440.00	28.24	11.31	39.55	54.00	14.45	Average	Horizontal
3	15660.00	42.67	11.00	53.67	74.00	20.33	Peak	Horizontal
4	15660.00	26.98	11.00	37.98	54.00	16.02	Average	Horizontal
5	10440.00	39.11	9.43	48.54	74.00	25.46	Peak	Vertical
6	10440.00	26.78	9.43	36.21	54.00	17.79	Average	Vertical
7	15660.00	41.17	11.93	53.10	74.00	20.90	Peak	Vertical
8	15660.00	26.78	11.93	38.71	54.00	15.29	Average	Vertical

IEEE 802.11ac-VHT20_Channel 48

No.	Frequency (MHz)	Reading (dBuV/m)	Correction factor (dB)	Result (dBuV/m)	Limit (dBuV/m)	Margin (dB)	Detector	Antenna Polaxis
1	10480.00	39.36	11.41	50.77	74.00	23.23	Peak	Horizontal
2	10480.00	27.70	11.41	39.11	54.00	14.89	Average	Horizontal
3	15720.00	44.65	11.08	55.73	74.00	18.27	Peak	Horizontal
4	15720.00	26.70	11.08	37.78	54.00	16.22	Average	Horizontal
5	10480.00	38.02	9.45	47.47	74.00	26.53	Peak	Vertical
6	10480.00	25.80	9.45	35.25	54.00	18.75	Average	Vertical
7	15720.00	45.34	12.05	57.39	74.00	16.61	Peak	Vertical
8	15720.00	29.24	12.05	41.29	54.00	12.71	Average	Vertical

TEST REPORT

IEEE 802.11ac-VHT20_Channel 52

No.	Frequency (MHz)	Reading (dBuV/m)	Correction factor (dB)	Result (dBuV/m)	Limit (dBuV/m)	Margin (dB)	Detector	Antenna Polaxis
1	10520.00	40.16	11.42	51.58	74.00	22.42	Peak	Horizontal
2	10520.00	27.87	11.42	39.29	54.00	14.71	Average	Horizontal
3	15780.00	44.23	11.16	55.39	74.00	18.61	Peak	Horizontal
4	15780.00	27.45	11.16	38.61	54.00	15.39	Average	Horizontal
5	10520.00	37.97	9.43	47.40	74.00	26.60	Peak	Vertical
6	10520.00	25.89	9.43	35.32	54.00	18.68	Average	Vertical
7	15780.00	45.60	12.19	57.79	74.00	16.21	Peak	Vertical
8	15780.00	27.36	12.19	39.55	54.00	14.45	Average	Vertical

IEEE 802.11ac-VHT20_Channel 60

No.	Frequency (MHz)	Reading (dBuV/m)	Correction factor (dB)	Result (dBuV/m)	Limit (dBuV/m)	Margin (dB)	Detector	Antenna Polaxis
1	10600.00	40.16	11.33	51.49	74.00	22.51	Peak	Horizontal
2	10600.00	27.81	11.33	39.14	54.00	14.86	Average	Horizontal
3	15900.00	43.65	11.33	54.98	74.00	19.02	Peak	Horizontal
4	15900.00	26.68	11.33	38.01	54.00	15.99	Average	Horizontal
5	10600.00	38.52	9.37	47.89	74.00	26.11	Peak	Vertical
6	10600.00	26.07	9.37	35.44	54.00	18.56	Average	Vertical
7	15900.00	47.35	12.45	59.80	74.00	14.20	Peak	Vertical
8	15900.00	29.22	12.45	41.67	54.00	12.33	Average	Vertical

IEEE 802.11ac-VHT20_Channel 64

No.	Frequency (MHz)	Reading (dBuV/m)	Correction factor (dB)	Result (dBuV/m)	Limit (dBuV/m)	Margin (dB)	Detector	Antenna Polaxis
1	4924.00	39.53	11.29	50.82	74.00	23.18	Peak	Horizontal
2	4924.00	27.91	11.29	39.20	54.00	14.80	Average	Horizontal
3	7386.00	42.86	11.49	54.35	74.00	19.65	Peak	Horizontal
4	7386.00	26.98	11.49	38.47	54.00	15.53	Average	Horizontal
5	4924.00	38.41	9.34	47.75	74.00	26.25	Peak	Vertical
6	4924.00	26.24	9.34	35.58	54.00	18.42	Average	Vertical
7	7386.00	49.11	12.66	61.77	74.00	12.23	Peak	Vertical
8	7386.00	27.58	12.66	40.24	54.00	13.76	Average	Vertical

TEST REPORT

IEEE 802.11ac-VHT20_Channel 100

No.	Frequency (MHz)	Reading (dBuV/m)	Correction factor (dB)	Result (dBuV/m)	Limit (dBuV/m)	Margin (dB)	Detector	Antenna Polaxis
1	11000.00	41.03	10.30	51.33	74.00	22.67	Peak	Horizontal
2	11000.00	28.57	10.30	38.87	54.00	15.13	Average	Horizontal
3	16500.00	45.41	13.35	58.76	74.00	15.24	Peak	Horizontal
4	16500.00	26.58	13.35	39.93	54.00	14.07	Average	Horizontal
5	11000.00	40.26	8.50	48.76	74.00	25.24	Peak	Vertical
6	11000.00	27.78	8.50	36.28	54.00	17.72	Average	Vertical
7	16500.00	45.92	13.45	59.37	74.00	14.63	Peak	Vertical
8	16500.00	24.43	13.45	37.88	54.00	16.12	Average	Vertical

IEEE 802.11ac-VHT20_Channel 116

No.	Frequency (MHz)	Reading (dBuV/m)	Correction factor (dB)	Result (dBuV/m)	Limit (dBuV/m)	Margin (dB)	Detector	Antenna Polaxis
1	11160.00	40.75	9.97	50.72	74.00	23.28	Peak	Horizontal
2	11160.00	27.98	9.97	37.95	54.00	16.05	Average	Horizontal
3	16740.00	42.85	13.24	56.09	74.00	17.91	Peak	Horizontal
4	16740.00	27.45	13.24	40.69	54.00	13.31	Average	Horizontal
5	11160.00	40.36	8.27	48.63	74.00	25.37	Peak	Vertical
6	11160.00	27.23	8.27	35.50	54.00	18.50	Average	Vertical
7	16740.00	46.25	13.01	59.26	74.00	14.74	Peak	Vertical
8	16740.00	27.25	13.01	40.26	54.00	13.74	Average	Vertical

IEEE 802.11ac-VHT20_Channel 140

No.	Frequency (MHz)	Reading (dBuV/m)	Correction factor (dB)	Result (dBuV/m)	Limit (dBuV/m)	Margin (dB)	Detector	Antenna Polaxis
1	11400.00	42.16	9.86	52.02	74.00	21.98	Peak	Horizontal
2	11400.00	28.95	9.86	38.81	54.00	15.19	Average	Horizontal
3	17100.00	38.60	13.42	52.02	74.00	21.98	Peak	Horizontal
4	17100.00	26.40	13.42	39.82	54.00	14.18	Average	Horizontal
5	11400.00	40.89	8.30	49.19	74.00	24.81	Peak	Vertical
6	11400.00	28.52	8.30	36.82	54.00	17.18	Average	Vertical
7	17100.00	42.33	12.76	55.09	74.00	18.91	Peak	Vertical
8	17100.00	23.77	12.76	36.53	54.00	17.47	Average	Vertical

TEST REPORT

IEEE 802.11ac-VHT20_Channel 149

No.	Frequency (MHz)	Reading (dBuV/m)	Correction factor (dB)	Result (dBuV/m)	Limit (dBuV/m)	Margin (dB)	Detector	Antenna Polaxis
1	11490.00	41.20	9.78	50.98	74.00	23.02	Peak	Horizontal
2	11490.00	28.53	9.78	38.31	54.00	15.69	Average	Horizontal
3	17235.00	42.87	13.98	56.85	74.00	17.15	Peak	Horizontal
4	17235.00	25.86	13.98	39.84	54.00	14.16	Average	Horizontal
5	11490.00	42.54	8.27	50.81	74.00	23.19	Peak	Vertical
6	11490.00	28.53	8.27	36.80	54.00	17.20	Average	Vertical
7	17235.00	42.70	13.24	55.94	74.00	18.06	Peak	Vertical
8	17235.00	25.60	13.24	38.84	54.00	15.16	Average	Vertical

IEEE 802.11ac-VHT20_Channel 157

No.	Frequency (MHz)	Reading (dBuV/m)	Correction factor (dB)	Result (dBuV/m)	Limit (dBuV/m)	Margin (dB)	Detector	Antenna Polaxis
1	11570.00	40.03	9.86	49.89	74.00	24.11	Peak	Horizontal
2	11570.00	28.09	9.86	37.95	54.00	16.05	Average	Horizontal
3	17355.00	39.56	14.49	54.05	74.00	19.95	Peak	Horizontal
4	17355.00	27.55	14.49	42.04	54.00	11.96	Average	Horizontal
5	11570.00	39.57	8.47	48.04	74.00	25.96	Peak	Vertical
6	11570.00	27.83	8.47	36.30	54.00	17.70	Average	Vertical
7	17355.00	39.74	13.41	53.15	74.00	20.85	Peak	Vertical
8	17355.00	27.48	13.41	40.89	54.00	13.11	Average	Vertical

IEEE 802.11ac-VHT20_Channel 165

No.	Frequency (MHz)	Reading (dBuV/m)	Correction factor (dB)	Result (dBuV/m)	Limit (dBuV/m)	Margin (dB)	Detector	Antenna Polaxis
1	11650.00	41.29	9.95	51.24	74.00	22.76	Peak	Horizontal
2	11650.00	28.42	9.95	38.37	54.00	15.63	Average	Horizontal
3	17475.00	46.04	14.89	60.93	74.00	13.07	Peak	Horizontal
4	17475.00	27.57	14.89	42.46	54.00	11.54	Average	Horizontal
5	11650.00	40.80	8.69	49.49	74.00	24.51	Peak	Vertical
6	11650.00	28.10	8.69	36.79	54.00	17.21	Average	Vertical
7	17475.00	39.48	14.00	53.48	74.00	20.52	Peak	Vertical
8	17475.00	26.60	14.00	40.60	54.00	13.40	Average	Vertical

TEST REPORT

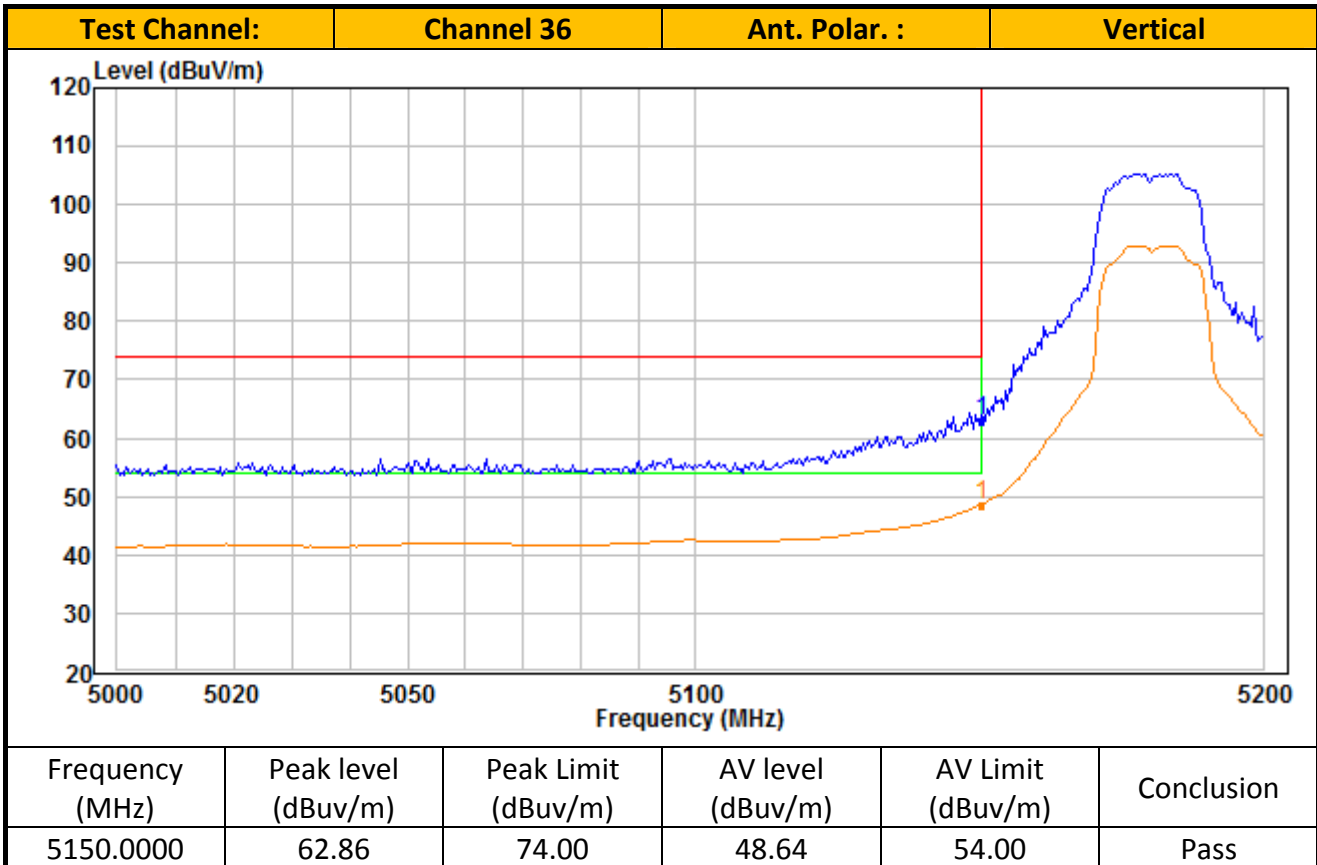
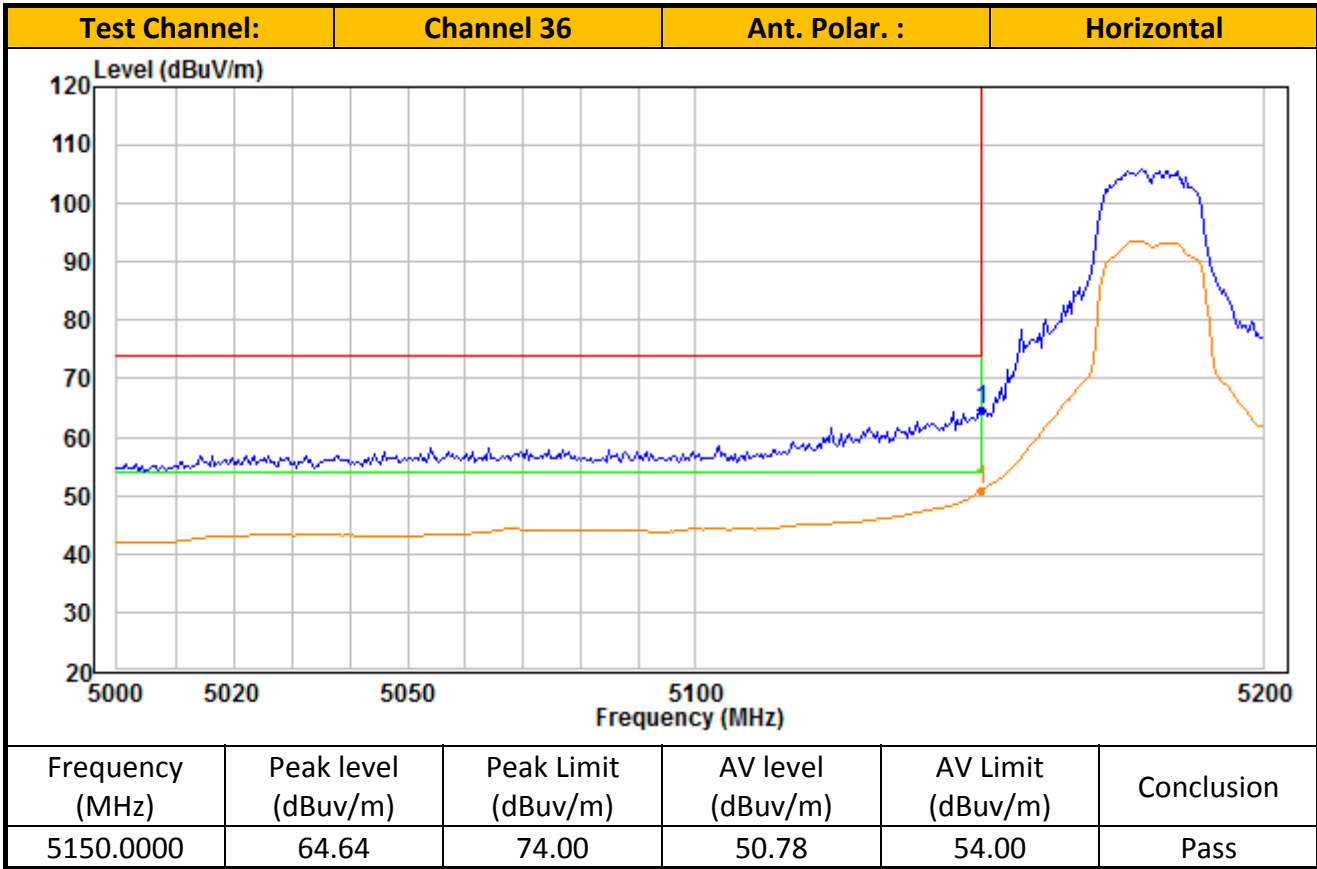

TEST REPORT

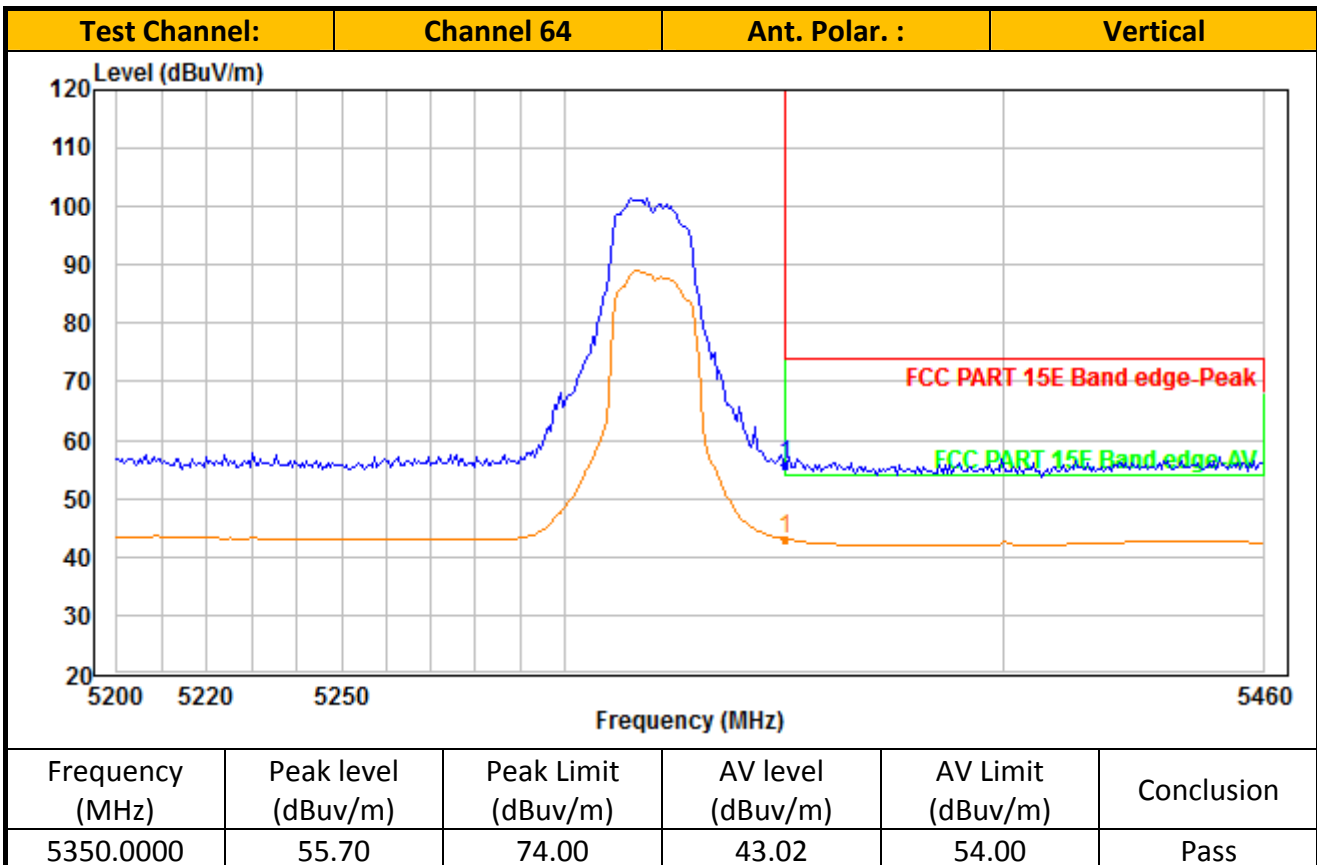
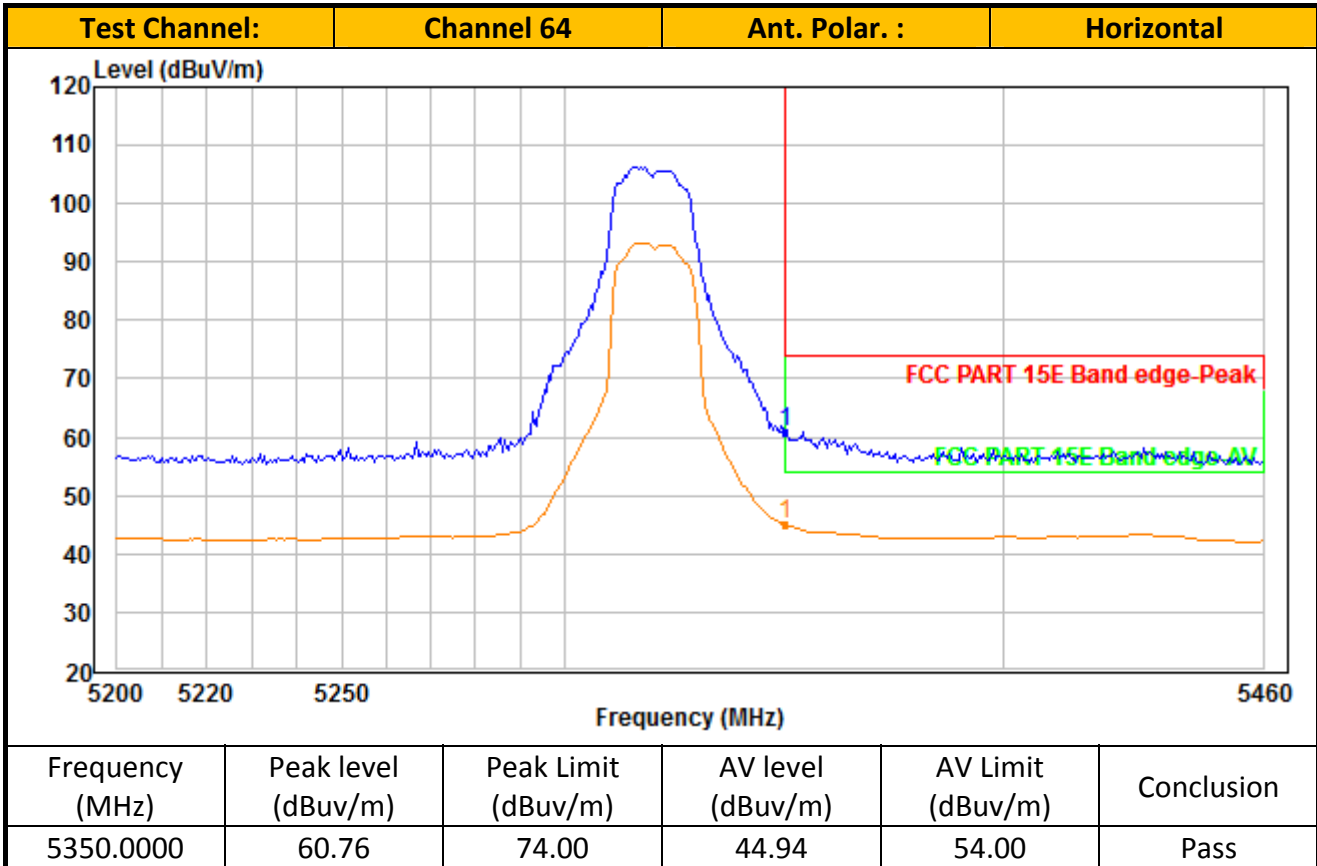

TEST REPORT

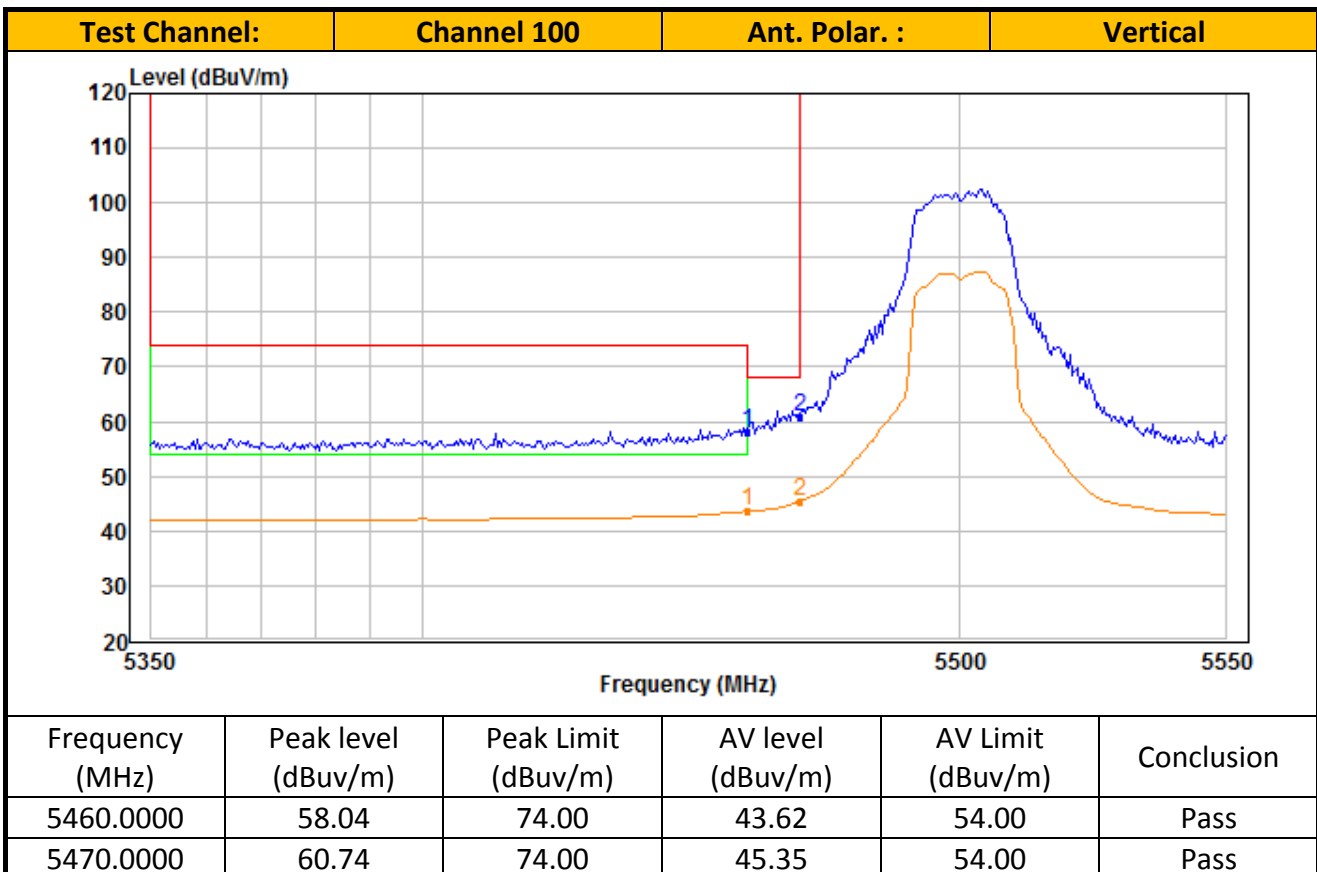
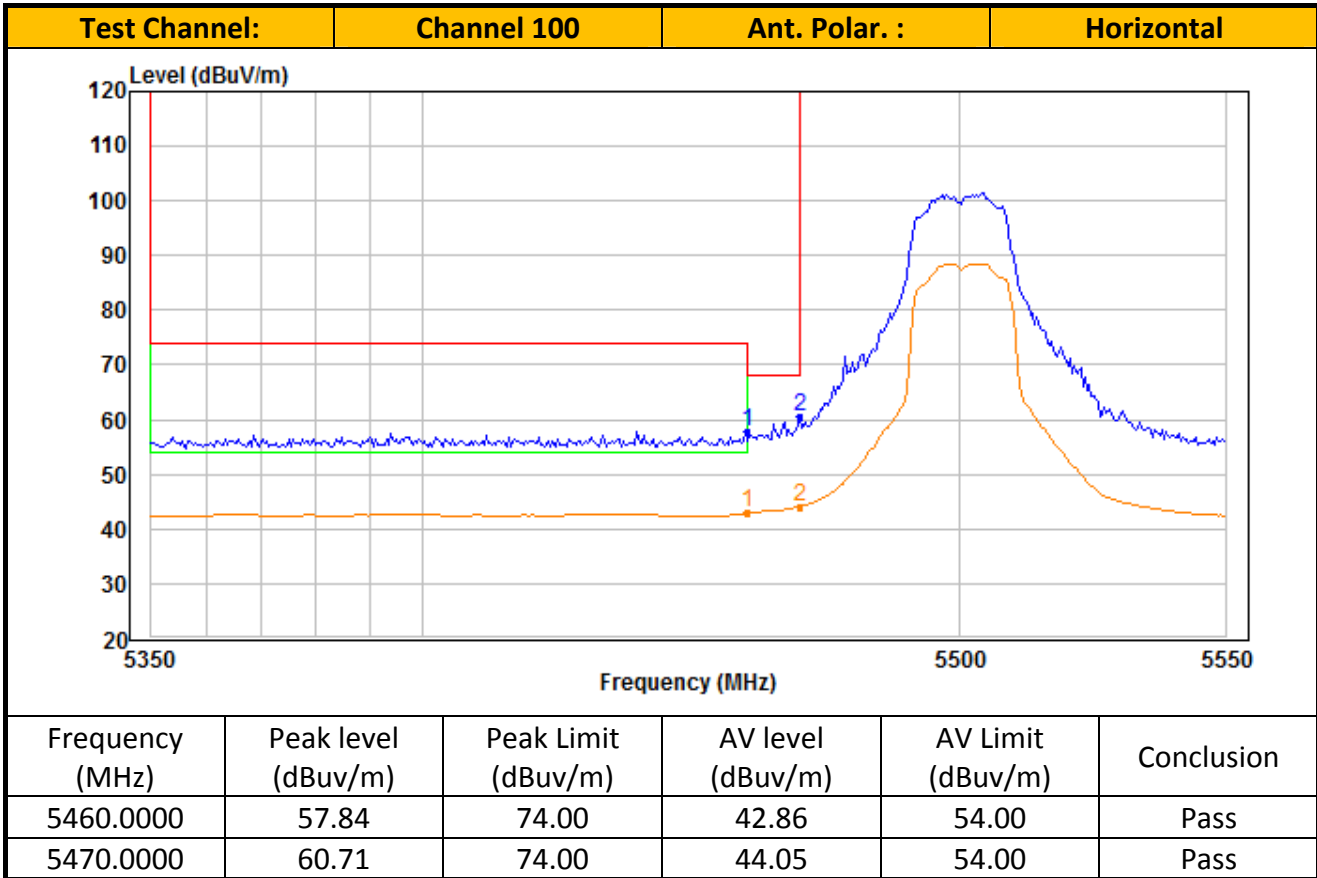

TEST REPORT

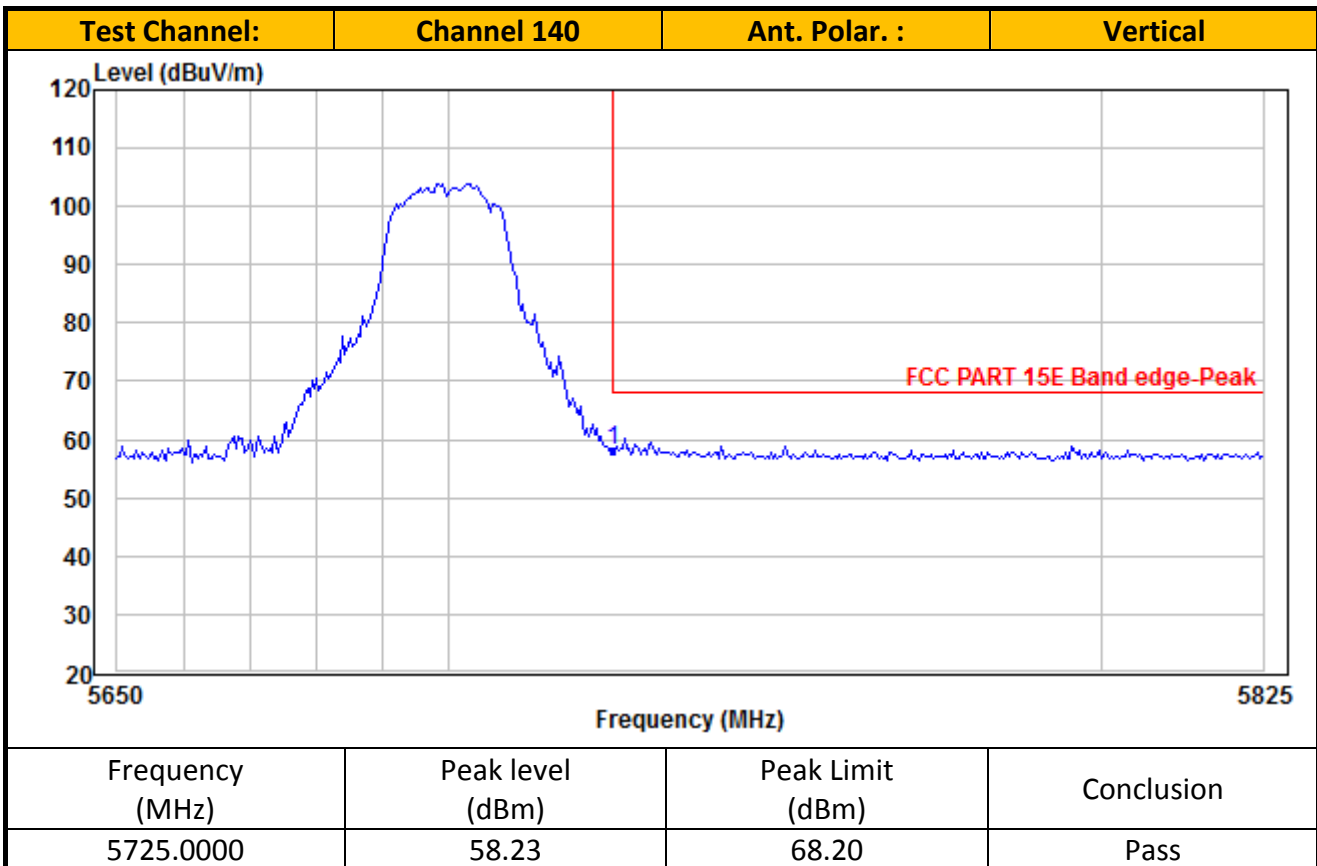
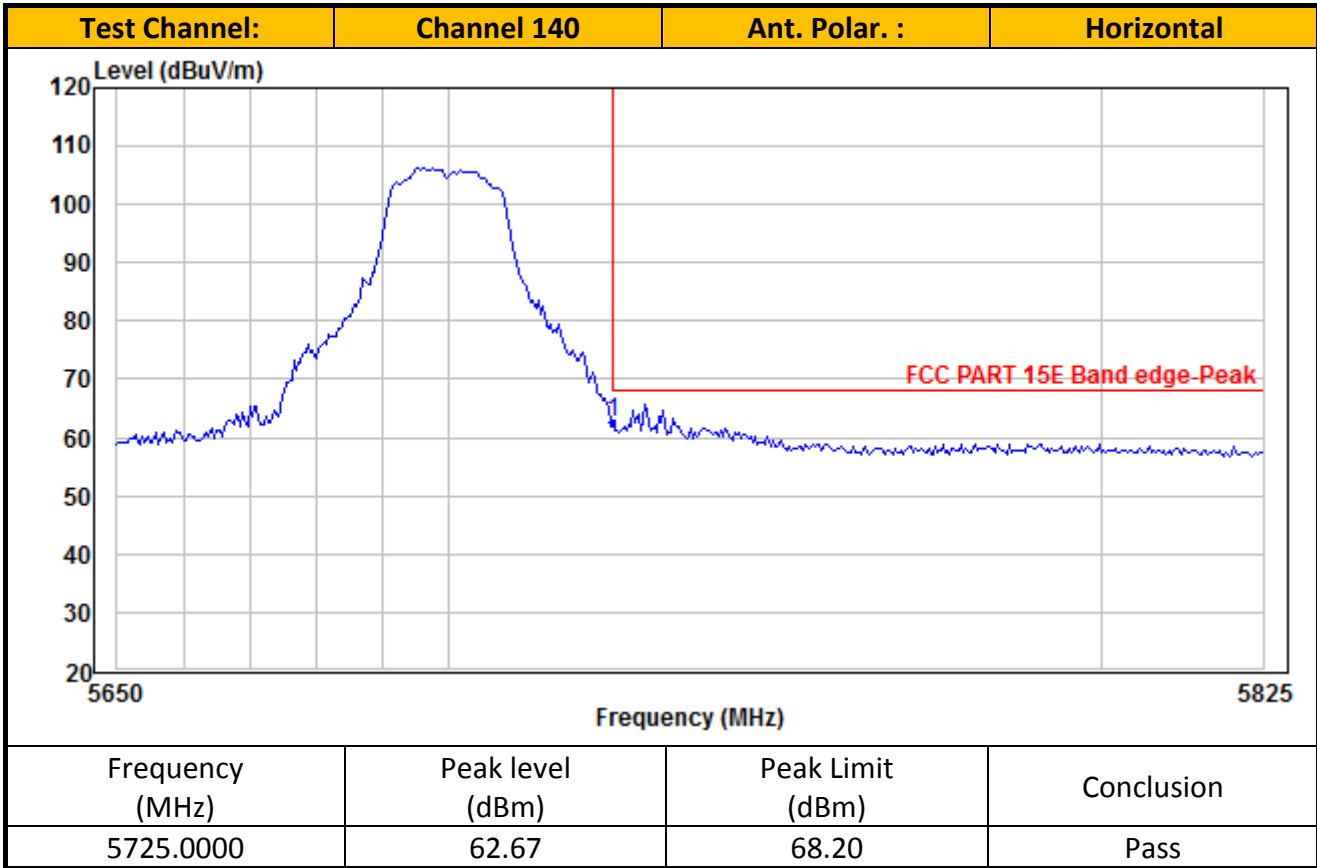

TEST REPORT

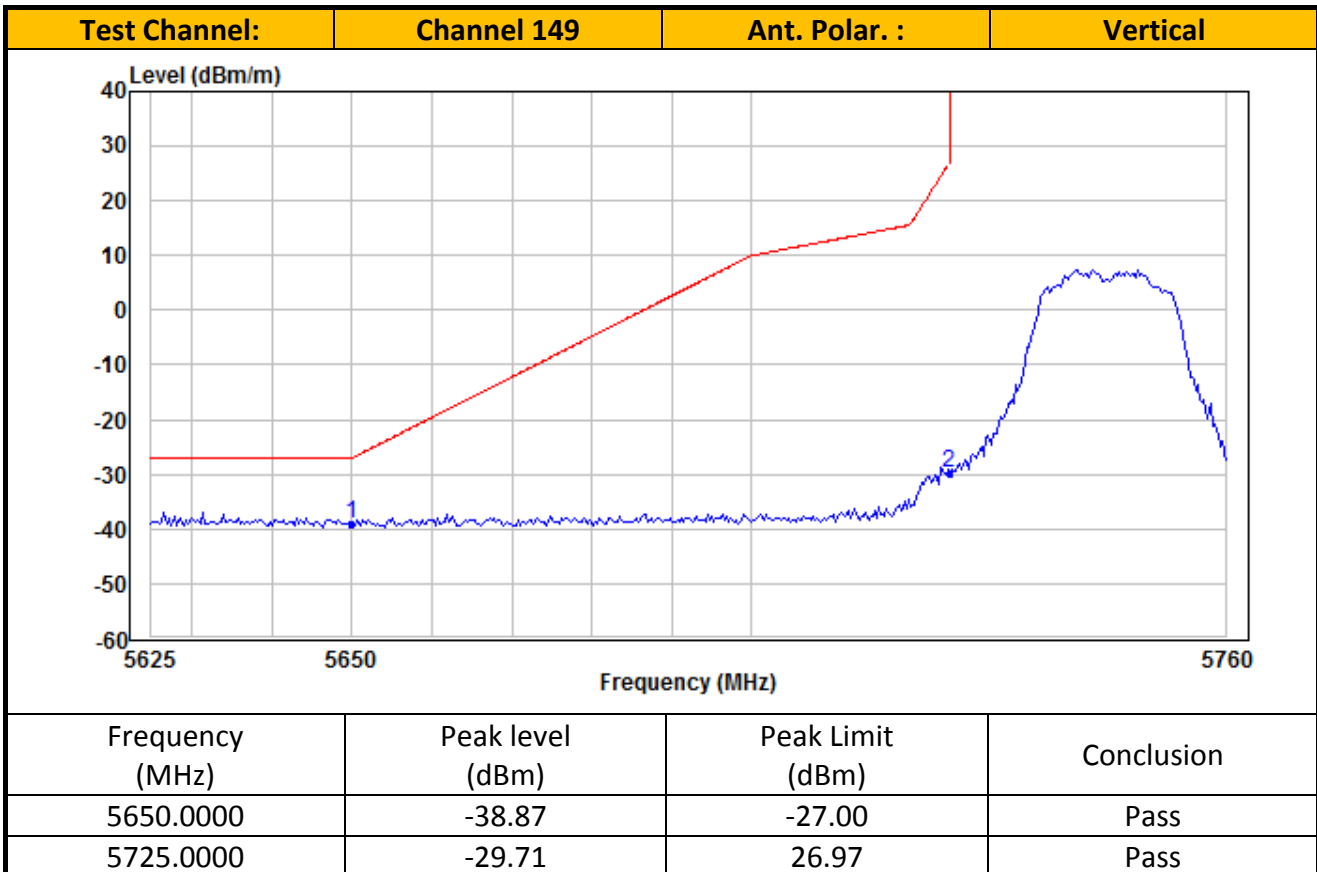
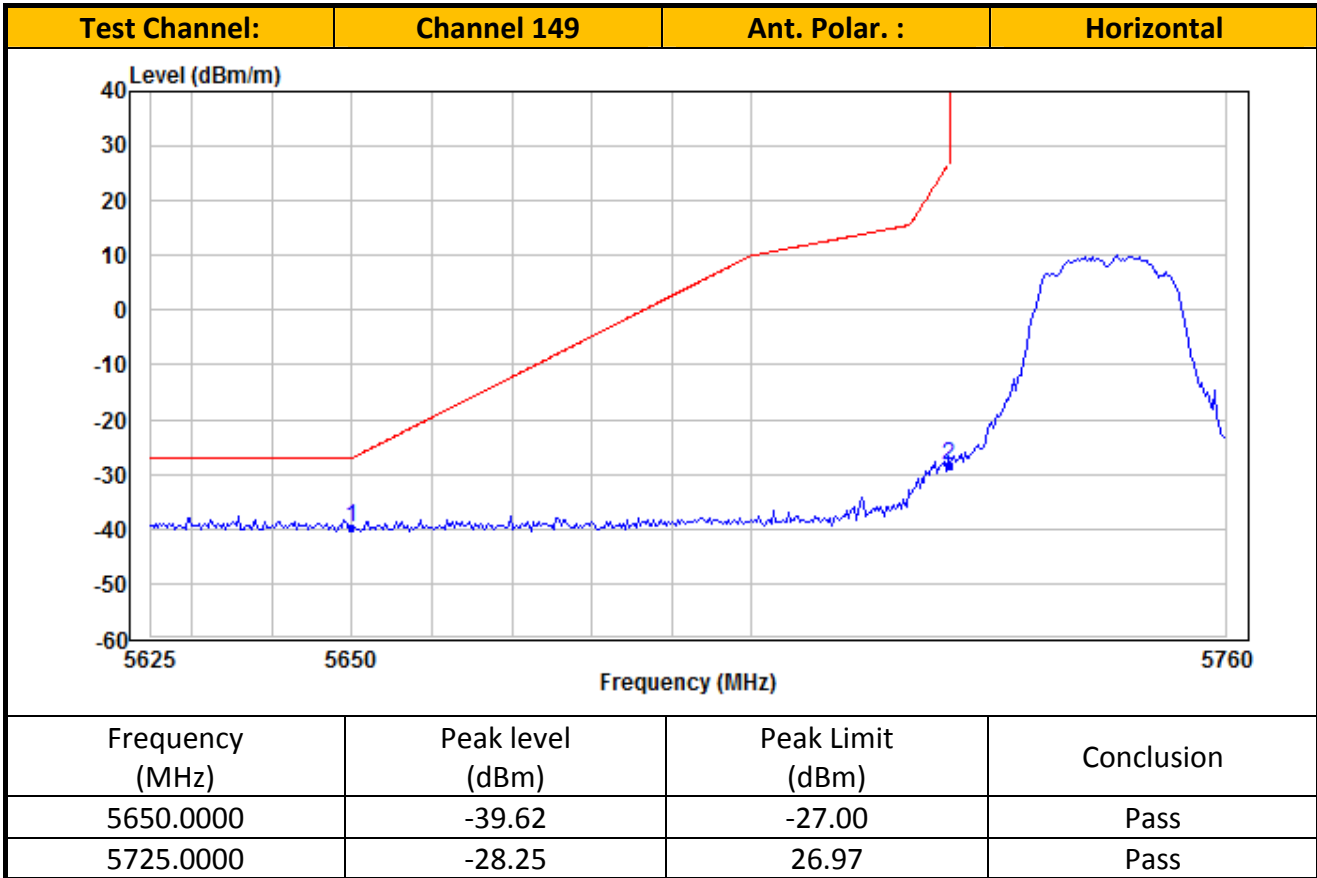

TEST REPORT

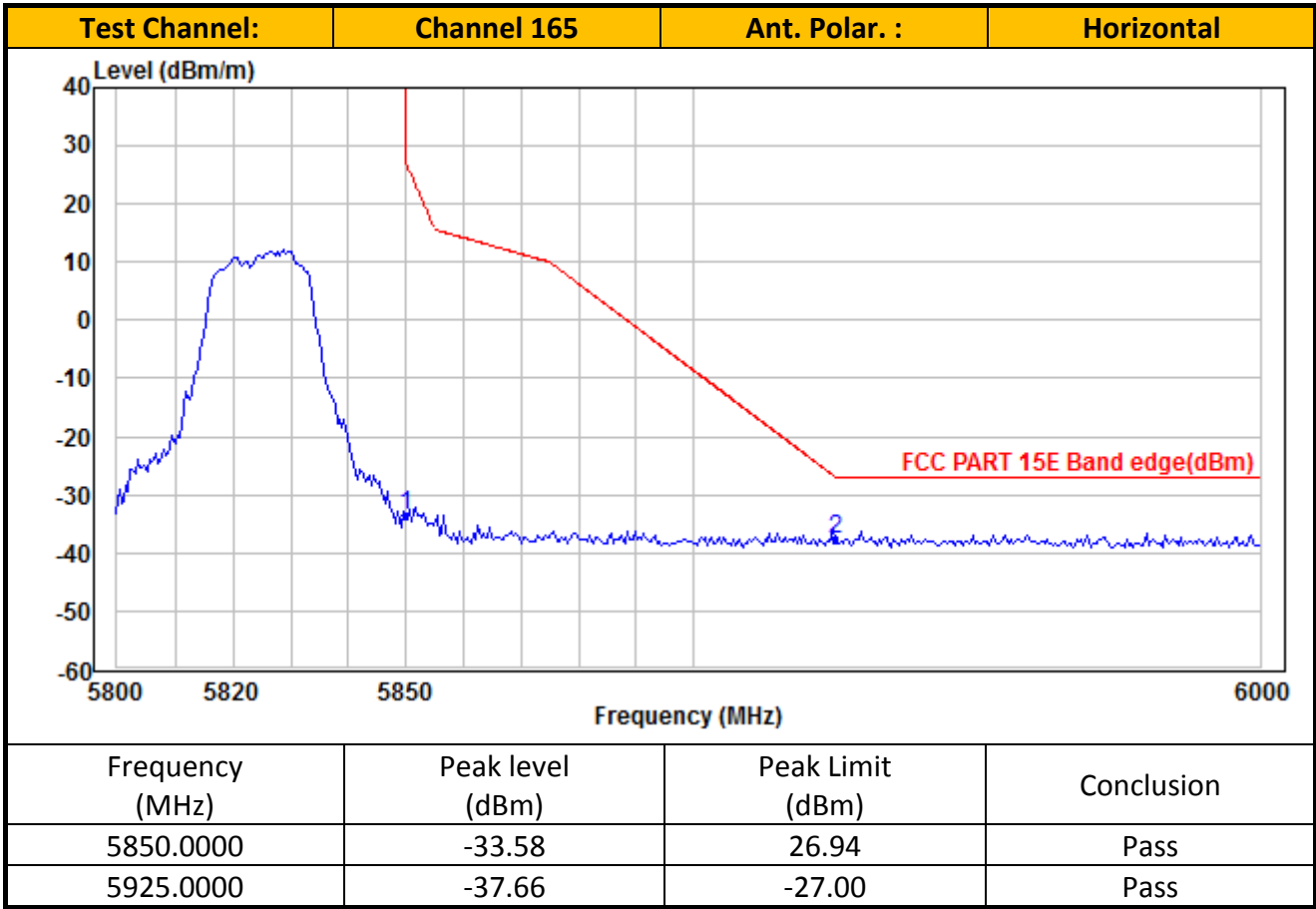

TEST REPORT

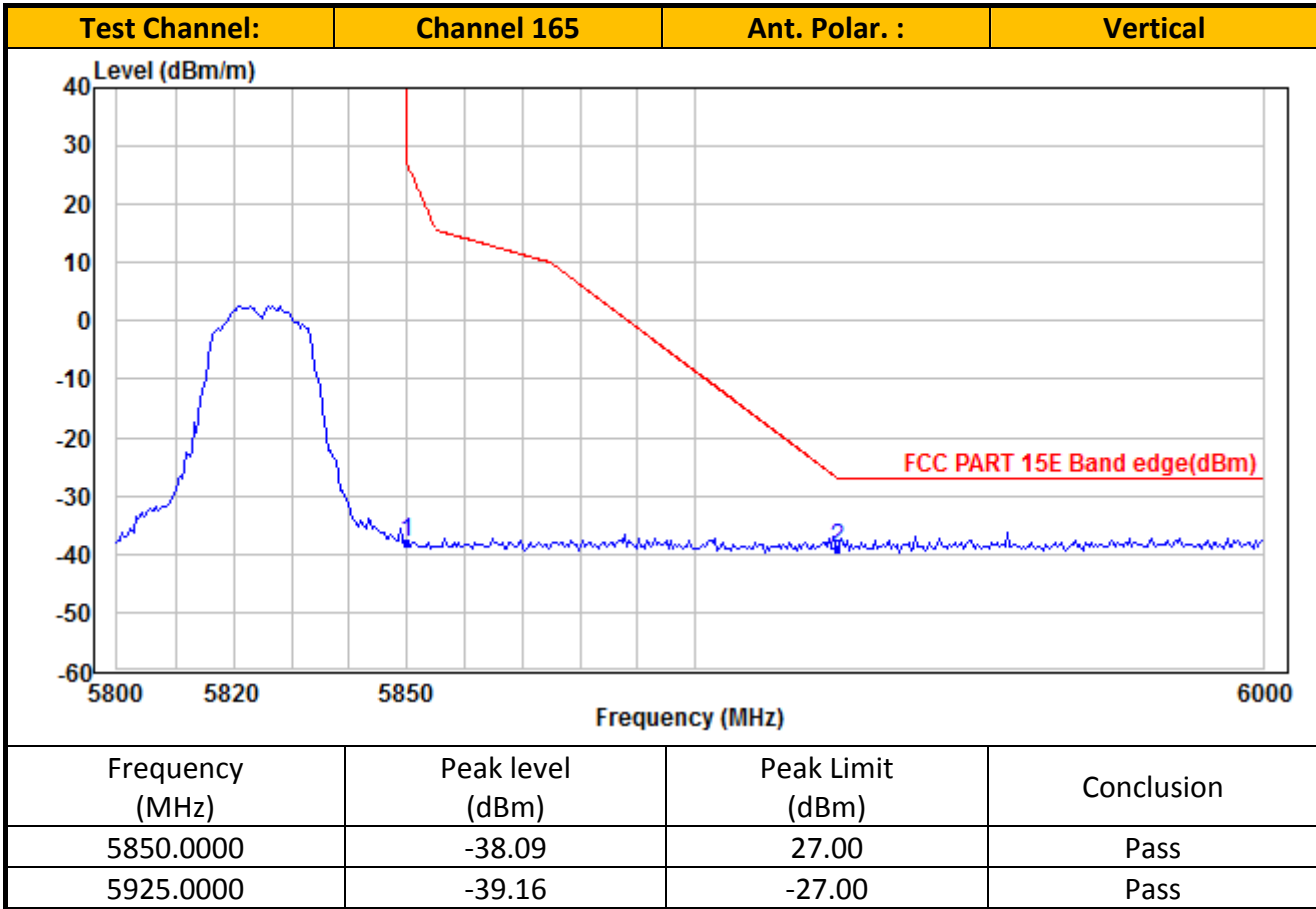

- NOTES:
1. Peak detector is used for the emission measurement.
 2. Average detector is used for the average data of emission measurement
 3. All measurements were made at 3 meters. Radiated emissions not detected at the 3-meter distance were measured at 0.3-meter and an inverse proportional extrapolation was performed to compare the signal level to the 3-meter limit. No other radiated emissions than those reported were detected at a test distance of 0.3-meter.
 4. Value in the margin column shows emission below limit.
 5. Horn antenna is used for the emission over 1000MHz.
 6. Emission (the row indicated by ***bold italic***) within the restricted band meets the requirement of FCC Part 15 Section 15.205.
 7. For the measurement of radiated emission, summation method was used which numerical integrating (in terms of linear power) over the transmitter occupied bandwidth.
 8. For the linear power measurement, data in 1MHz spacing was collected by spectrum analyzer with 1MHz resolution bandwidth.

TEST REPORT

Frequency: 5190MHz
Ant. 1_ IEEE 802.11ac (40MHz) (MCS0)

IEEE 802.11ac-VHT40_Channel 38

No.	Frequency (MHz)	Reading (dBuV/m)	Correction factor (dB)	Result (dBuV/m)	Limit (dBuV/m)	Margin (dB)	Detector	Antenna Polaxis
1	10380.00	41.42	11.17	52.59	74.00	21.41	Peak	Horizontal
2	10380.00	29.04	11.17	40.21	54.00	13.79	Average	Horizontal
3	15570.00	37.74	10.84	48.58	74.00	25.42	Peak	Horizontal
4	15570.00	25.81	10.84	36.65	54.00	17.35	Average	Horizontal
5	10380.00	39.87	9.41	49.28	74.00	24.72	Peak	Vertical
6	10380.00	27.35	9.41	36.76	54.00	17.24	Average	Vertical
7	15570.00	41.04	11.69	52.73	74.00	21.27	Peak	Vertical
8	15570.00	26.32	11.69	38.01	54.00	15.99	Average	Vertical

IEEE 802.11ac-VHT40_Channel 46

No.	Frequency (MHz)	Reading (dBuV/m)	Correction factor (dB)	Result (dBuV/m)	Limit (dBuV/m)	Margin (dB)	Detector	Antenna Polaxis
1	10460.00	40.37	11.35	51.72	74.00	22.28	Peak	Horizontal
2	10460.00	29.06	11.35	40.41	54.00	13.59	Average	Horizontal
3	15690.00	41.47	11.03	52.50	74.00	21.50	Peak	Horizontal
4	15690.00	27.27	11.03	38.30	54.00	15.70	Average	Horizontal
5	10460.00	39.38	9.43	48.81	74.00	25.19	Peak	Vertical
6	10460.00	27.90	9.43	37.33	54.00	16.67	Average	Vertical
7	15690.00	41.00	11.98	52.98	74.00	21.02	Peak	Vertical
8	15690.00	27.62	11.98	39.60	54.00	14.40	Average	Vertical

IEEE 802.11ac-VHT40_Channel 54

No.	Frequency (MHz)	Reading (dBuV/m)	Correction factor (dB)	Result (dBuV/m)	Limit (dBuV/m)	Margin (dB)	Detector	Antenna Polaxis
1	10540.00	40.18	11.41	51.59	74.00	22.41	Peak	Horizontal
2	10540.00	28.09	11.41	39.50	54.00	14.50	Average	Horizontal
3	15810.00	41.41	11.21	52.62	74.00	21.38	Peak	Horizontal
4	15810.00	24.48	11.21	35.69	54.00	18.31	Average	Horizontal
5	10540.00	39.21	9.42	48.63	74.00	25.37	Peak	Vertical
6	10540.00	27.46	9.42	36.88	54.00	17.12	Average	Vertical
7	15810.00	40.61	12.26	52.87	74.00	21.13	Peak	Vertical
8	15810.00	27.93	12.26	40.19	54.00	13.81	Average	Vertical

TEST REPORT

IEEE 802.11ac-VHT40_Channel 62

No.	Frequency (MHz)	Reading (dBuV/m)	Correction factor (dB)	Result (dBuV/m)	Limit (dBuV/m)	Margin (dB)	Detector	Antenna Polaxis
1	10620.00	39.75	11.30	51.05	74.00	22.95	Peak	Horizontal
2	10620.00	28.30	11.30	39.60	54.00	14.40	Average	Horizontal
3	15930.00	38.47	11.41	49.88	74.00	24.12	Peak	Horizontal
4	15930.00	25.74	11.41	37.15	54.00	16.85	Average	Horizontal
5	10620.00	39.23	9.35	48.58	74.00	25.42	Peak	Vertical
6	10620.00	27.17	9.35	36.52	54.00	17.48	Average	Vertical
7	15930.00	37.67	12.56	50.23	74.00	23.77	Peak	Vertical
8	15930.00	25.89	12.56	38.45	54.00	15.55	Average	Vertical

IEEE 802.11ac-VHT40_Channel 102

No.	Frequency (MHz)	Reading (dBuV/m)	Correction factor (dB)	Result (dBuV/m)	Limit (dBuV/m)	Margin (dB)	Detector	Antenna Polaxis
1	11020.00	41.08	10.24	51.32	74.00	22.68	Peak	Horizontal
2	11020.00	29.20	10.24	39.44	54.00	14.56	Average	Horizontal
3	16530.00	39.27	13.34	52.61	74.00	21.39	Peak	Horizontal
4	16530.00	25.95	13.34	39.29	54.00	14.71	Average	Horizontal
5	11020.00	40.36	8.45	48.81	74.00	25.19	Peak	Vertical
6	11020.00	28.56	8.45	37.01	54.00	16.99	Average	Vertical
7	16530.00	39.90	13.40	53.30	74.00	20.70	Peak	Vertical
8	16530.00	25.47	13.40	38.87	54.00	15.13	Average	Vertical

IEEE 802.11ac-VHT40_Channel 110

No.	Frequency (MHz)	Reading (dBuV/m)	Correction factor (dB)	Result (dBuV/m)	Limit (dBuV/m)	Margin (dB)	Detector	Antenna Polaxis
1	11100.00	40.63	10.30	50.93	74.00	23.07	Peak	Horizontal
2	11100.00	29.14	10.30	39.44	54.00	14.56	Average	Horizontal
3	16650.00	37.71	13.29	51.00	74.00	23.00	Peak	Horizontal
4	16650.00	25.85	13.29	39.14	54.00	14.86	Average	Horizontal
5	11100.00	40.01	8.50	48.51	74.00	25.49	Peak	Vertical
6	11100.00	28.40	8.50	36.90	54.00	17.10	Average	Vertical
7	16650.00	38.57	13.18	51.75	74.00	22.25	Peak	Vertical
8	16650.00	25.79	13.18	38.97	54.00	15.03	Average	Vertical

TEST REPORT

IEEE 802.11ac-VHT40_Channel 134

No.	Frequency (MHz)	Reading (dBuV/m)	Correction factor (dB)	Result (dBuV/m)	Limit (dBuV/m)	Margin (dB)	Detector	Antenna Polaxis
1	11340.00	41.49	9.89	51.38	74.00	22.62	Peak	Horizontal
2	11340.00	29.10	9.89	38.99	54.00	15.01	Average	Horizontal
3	17010.00	37.84	13.18	51.02	74.00	22.98	Peak	Horizontal
4	17010.00	25.32	13.18	38.50	54.00	15.50	Average	Horizontal
5	11340.00	40.29	8.29	48.58	74.00	25.42	Peak	Vertical
6	11340.00	28.47	8.29	36.76	54.00	17.24	Average	Vertical
7	17010.00	37.25	12.57	49.82	74.00	24.18	Peak	Vertical
8	17010.00	25.35	12.57	37.92	54.00	16.08	Average	Vertical

IEEE 802.11ac-VHT40_Channel 151

No.	Frequency (MHz)	Reading (dBuV/m)	Correction factor (dB)	Result (dBuV/m)	Limit (dBuV/m)	Margin (dB)	Detector	Antenna Polaxis
1	11510.00	40.94	9.79	50.73	74.00	23.27	Peak	Horizontal
2	11510.00	29.30	9.79	39.09	54.00	14.91	Average	Horizontal
3	17265.00	41.97	-35.89	6.08	74.00	67.92	Peak	Horizontal
4	17265.00	77.66	-35.89	41.77	54.00	12.23	Average	Horizontal
5	11510.00	41.19	8.30	49.49	74.00	24.51	Peak	Vertical
6	11510.00	28.92	8.30	37.22	54.00	16.78	Average	Vertical
7	17265.00	38.98	13.35	52.33	74.00	21.67	Peak	Vertical
8	17265.00	25.95	13.35	39.30	54.00	14.70	Average	Vertical

IEEE 802.11ac-VHT40_Channel 159

No.	Frequency (MHz)	Reading (dBuV/m)	Correction factor (dB)	Result (dBuV/m)	Limit (dBuV/m)	Margin (dB)	Detector	Antenna Polaxis
1	11590.00	41.31	9.87	51.18	74.00	22.82	Peak	Horizontal
2	11590.00	28.19	9.87	38.06	54.00	15.94	Average	Horizontal
3	17385.00	39.00	14.62	53.62	74.00	20.38	Peak	Horizontal
4	17385.00	27.35	14.62	41.97	54.00	12.03	Average	Horizontal
5	11590.00	40.14	8.52	48.66	74.00	25.34	Peak	Vertical
6	11590.00	28.19	8.52	36.71	54.00	17.29	Average	Vertical
7	17385.00	40.01	13.79	53.80	74.00	20.20	Peak	Vertical
8	17385.00	27.54	13.79	41.33	54.00	12.67	Average	Vertical

TEST REPORT

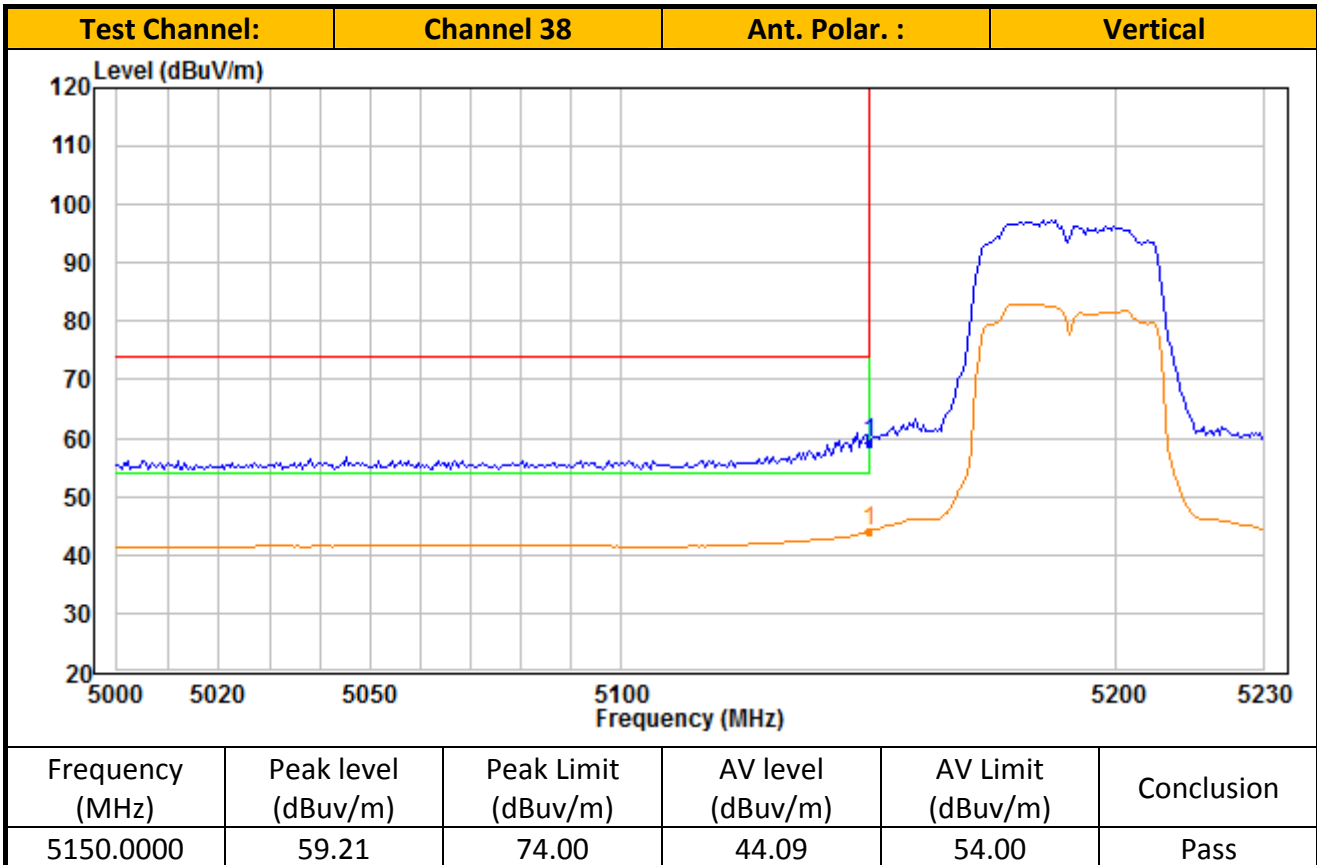
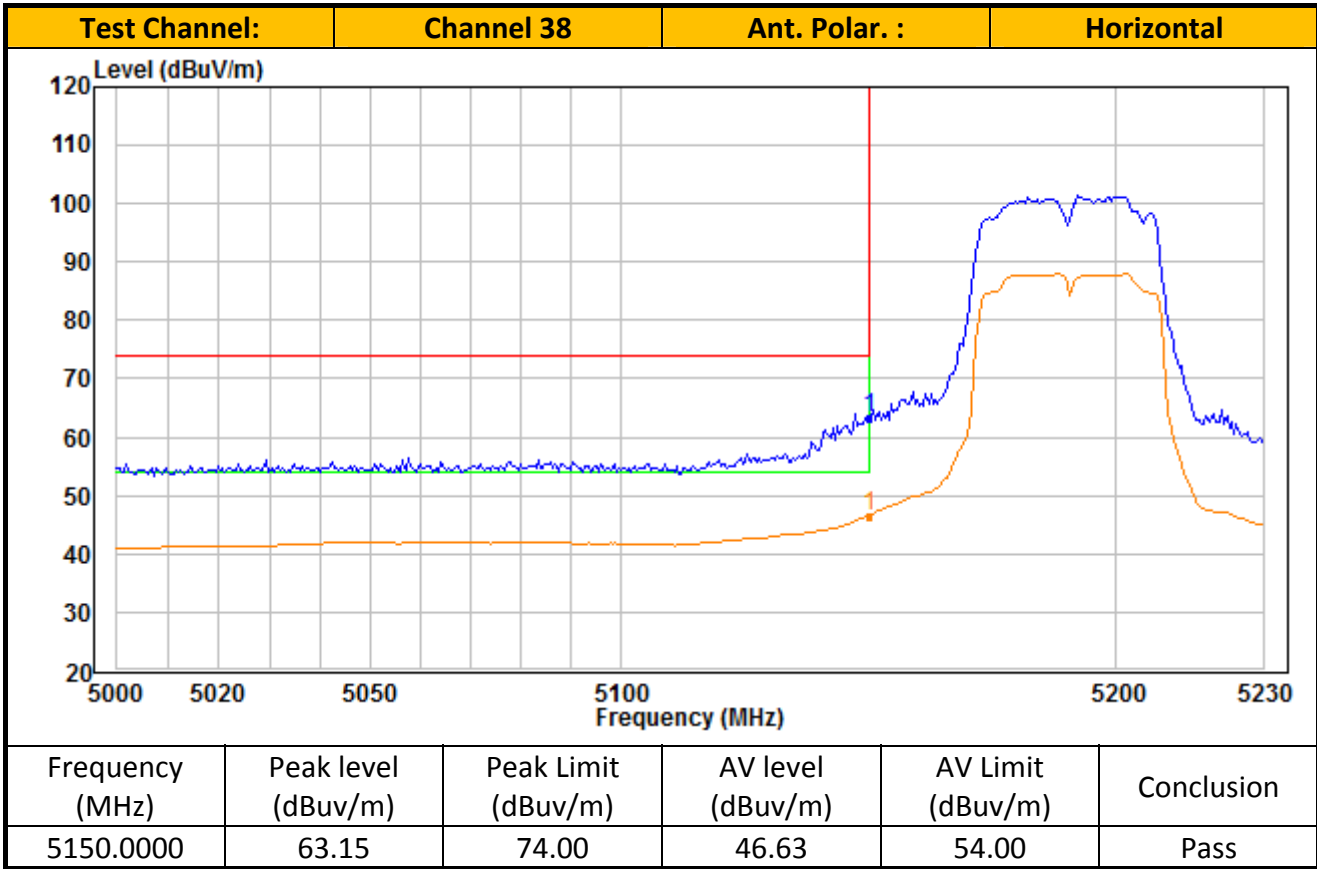

TEST REPORT

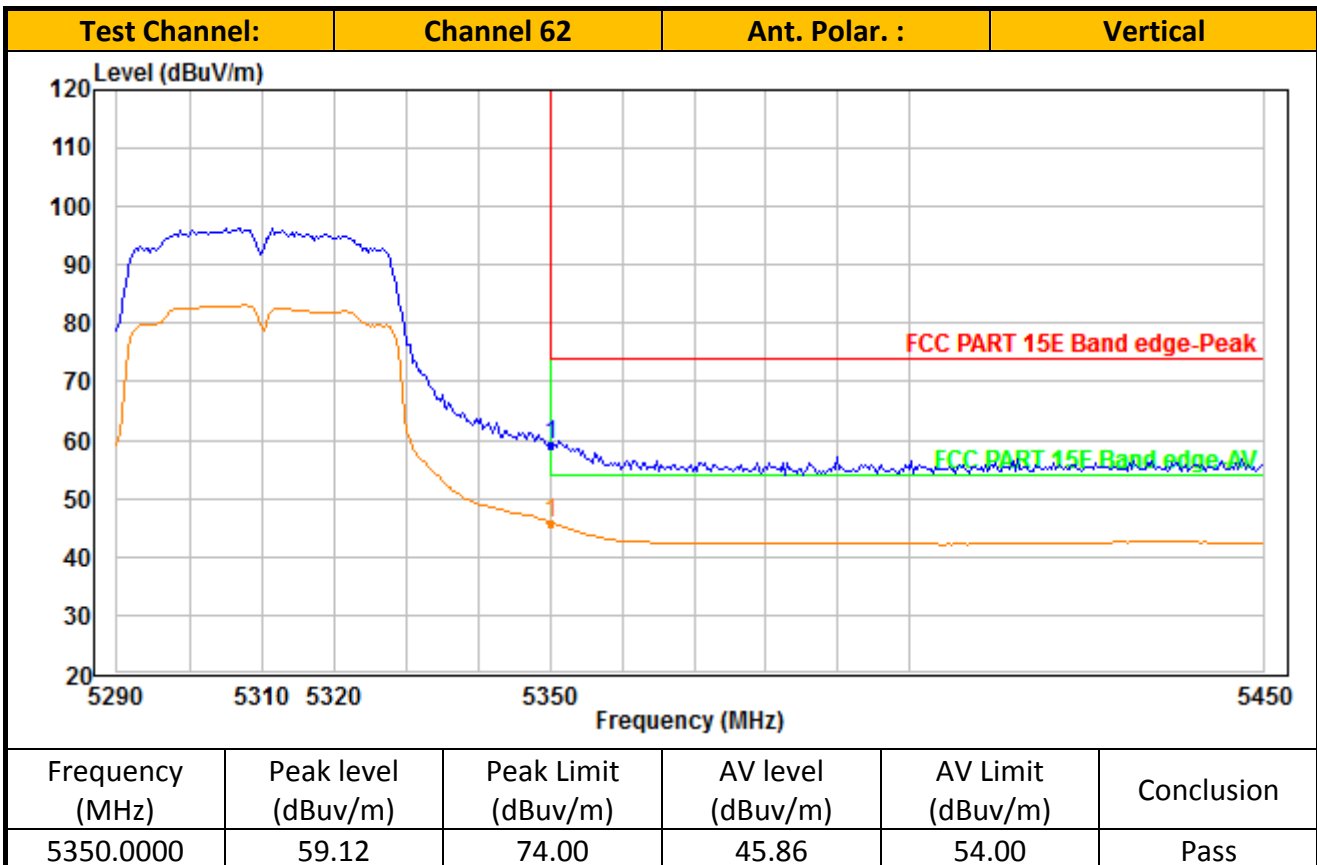
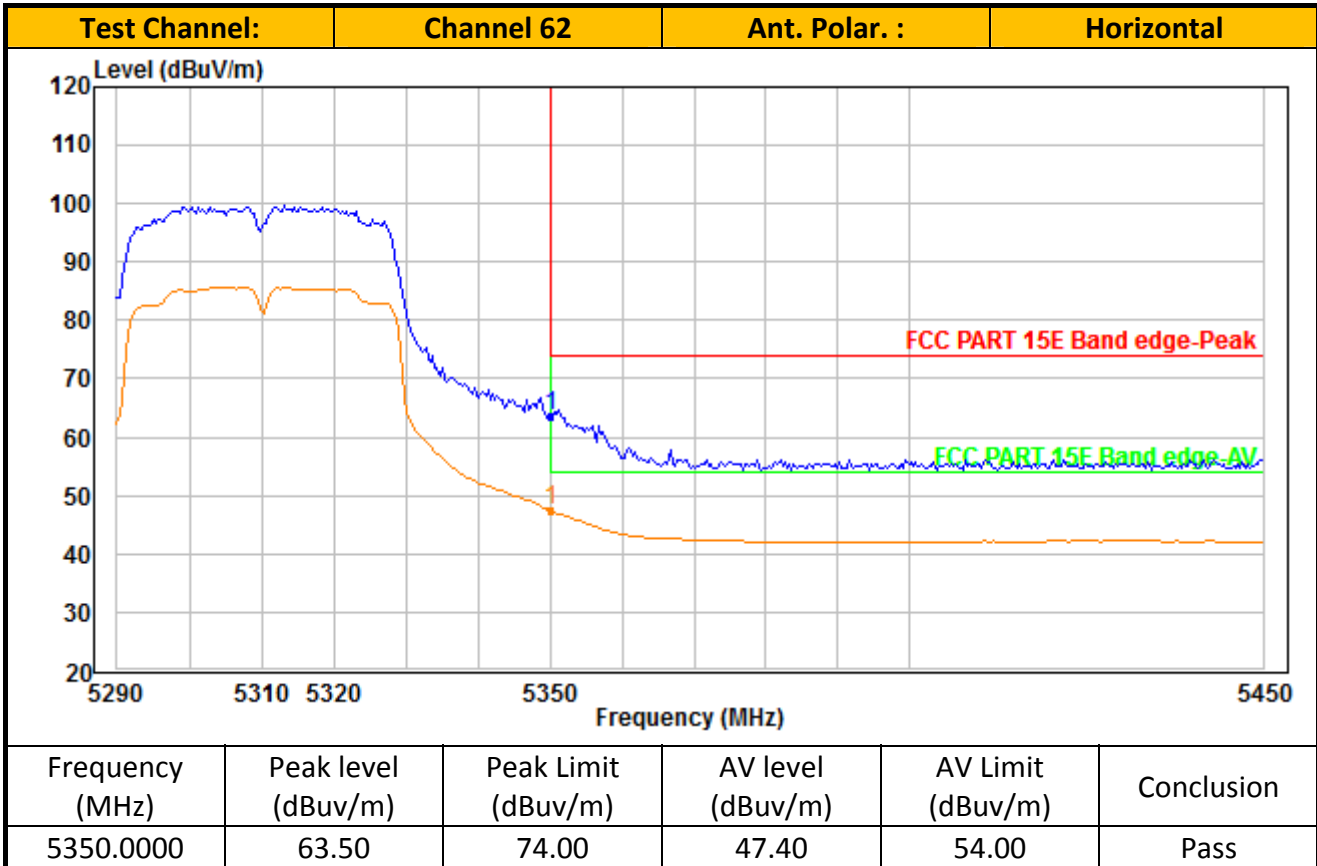

TEST REPORT

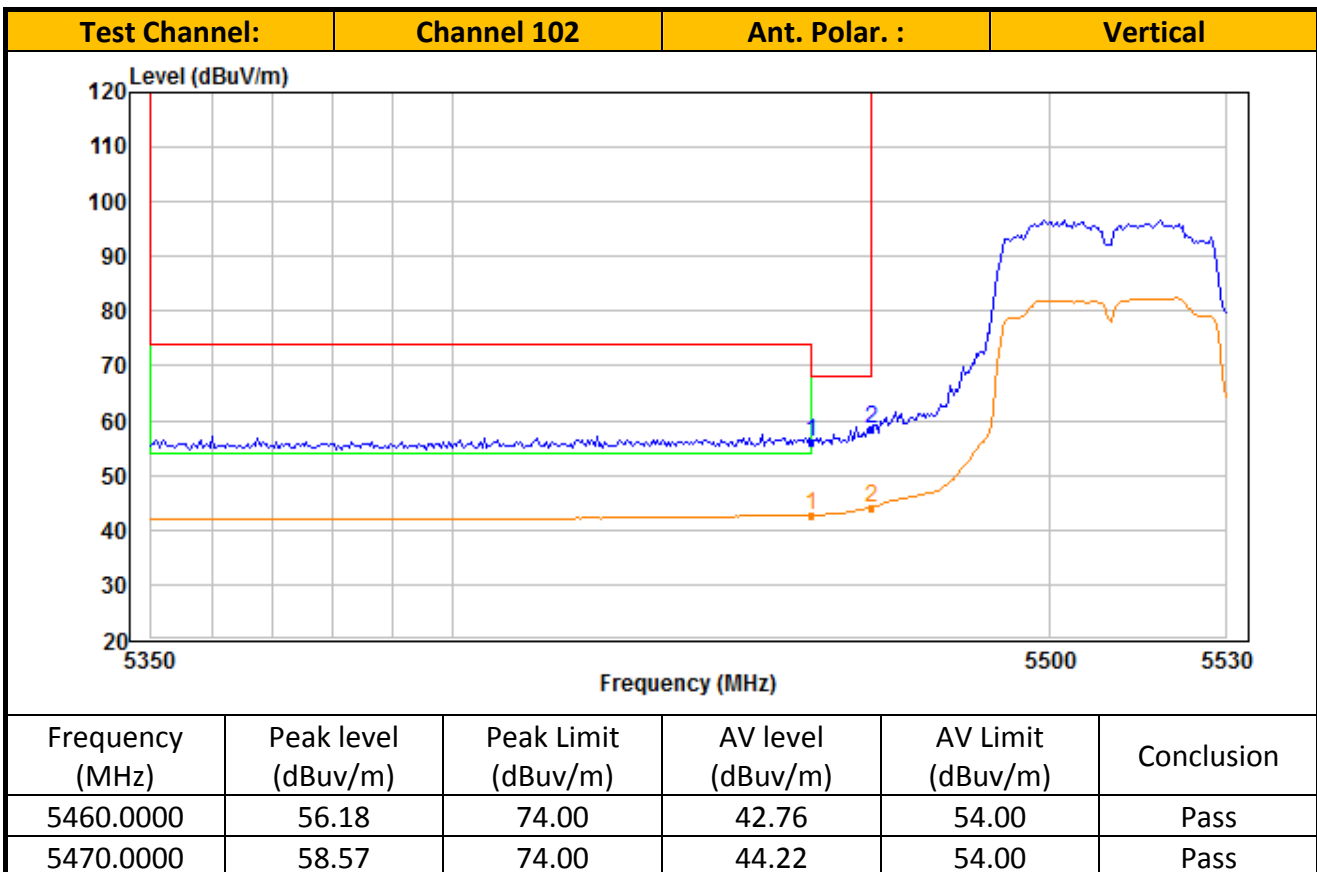
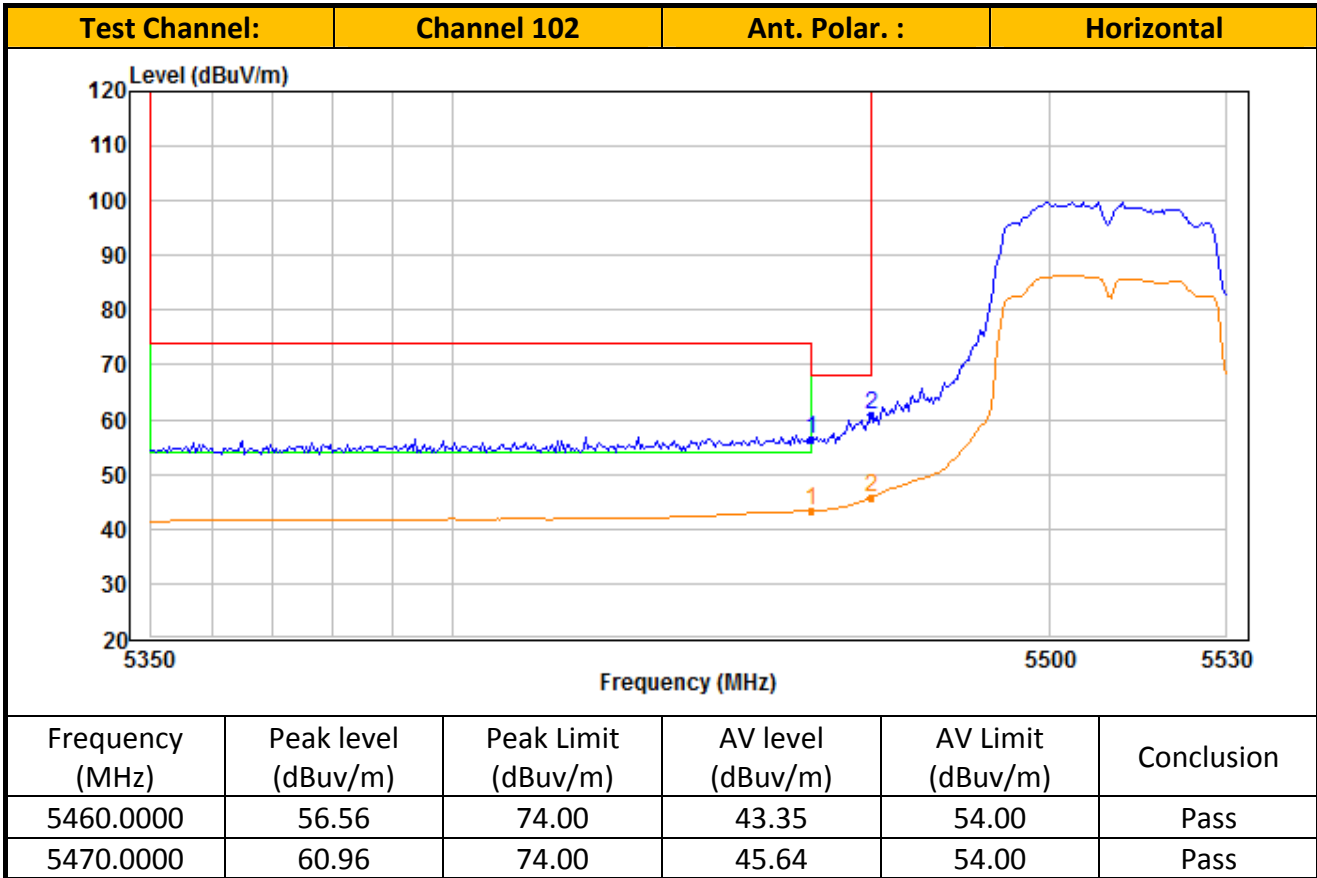

TEST REPORT

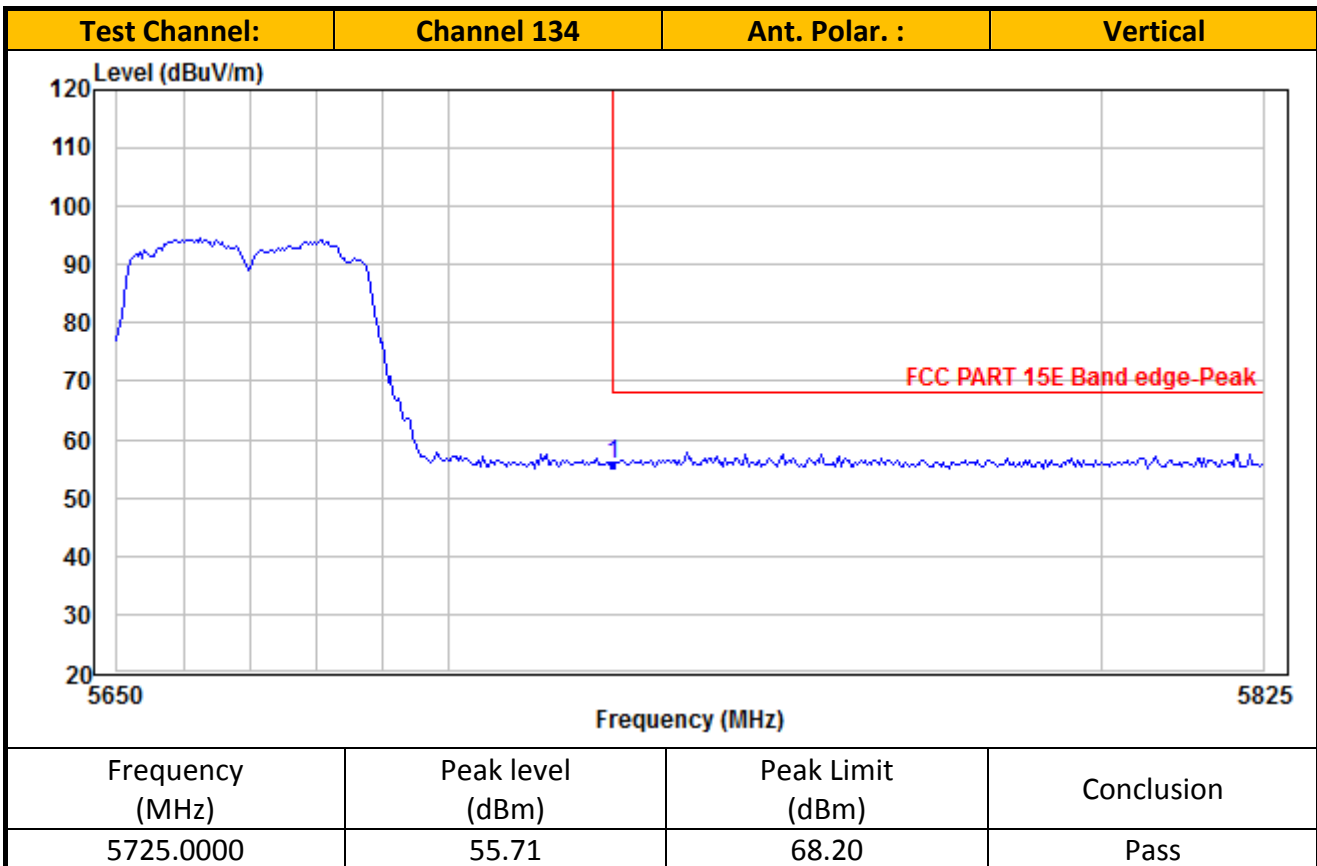
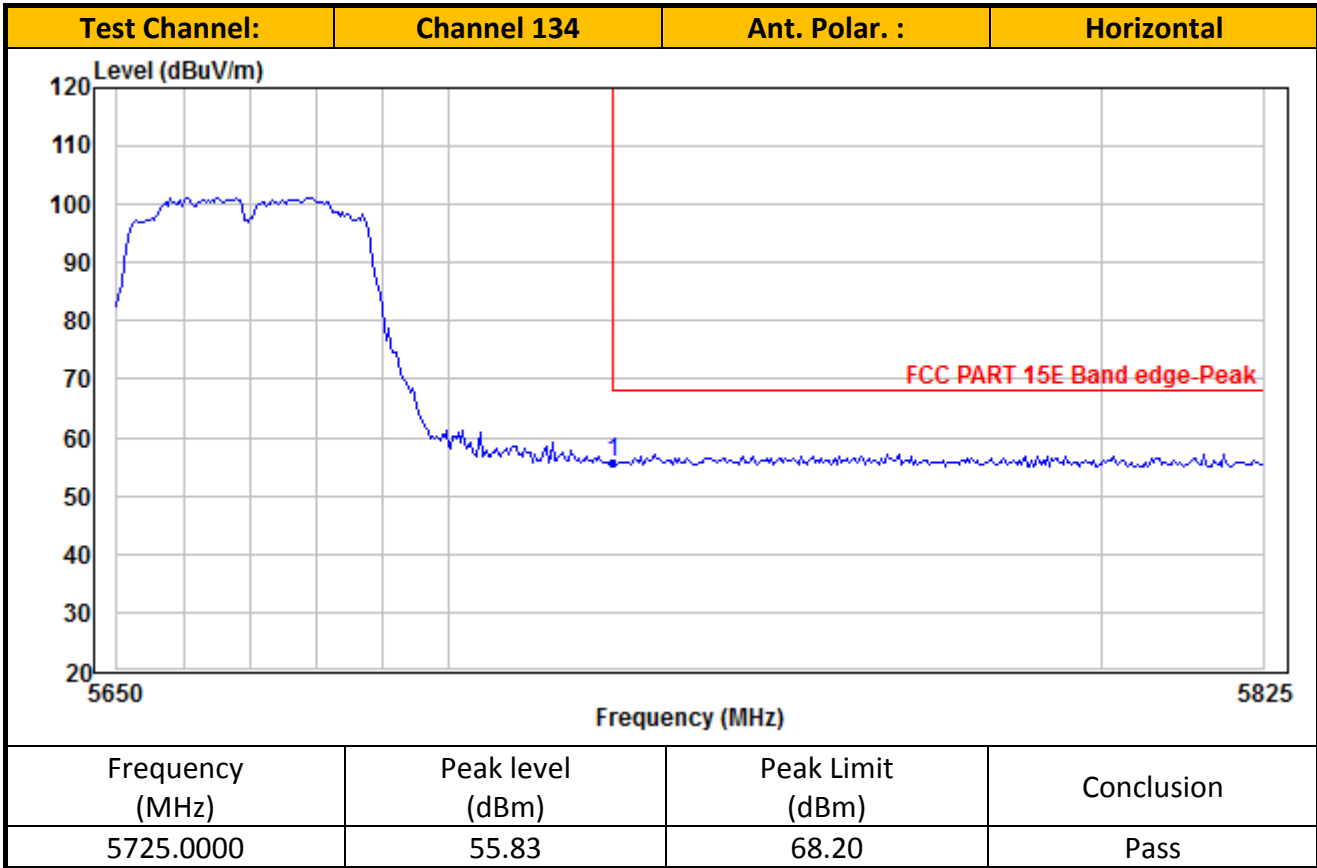

TEST REPORT

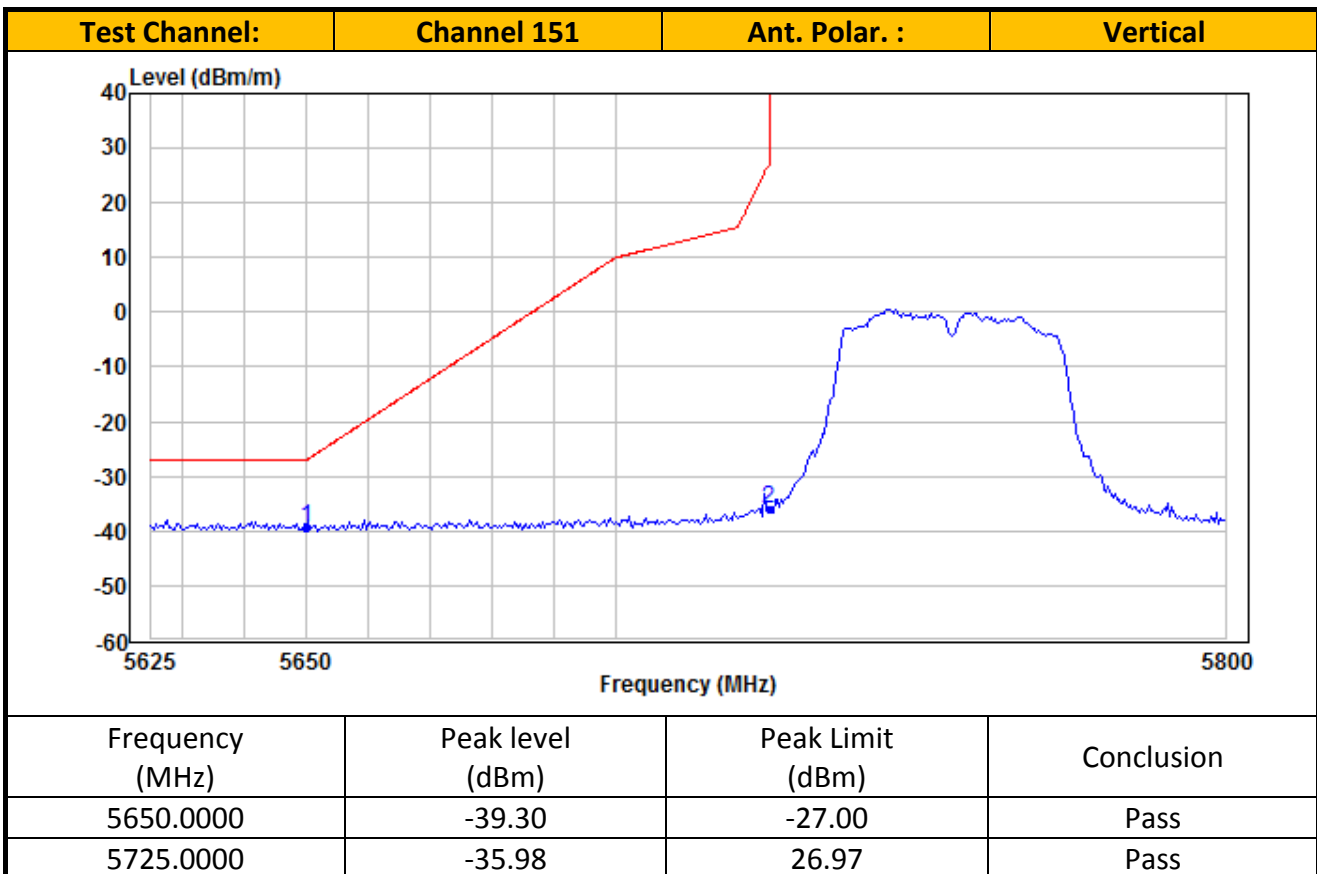
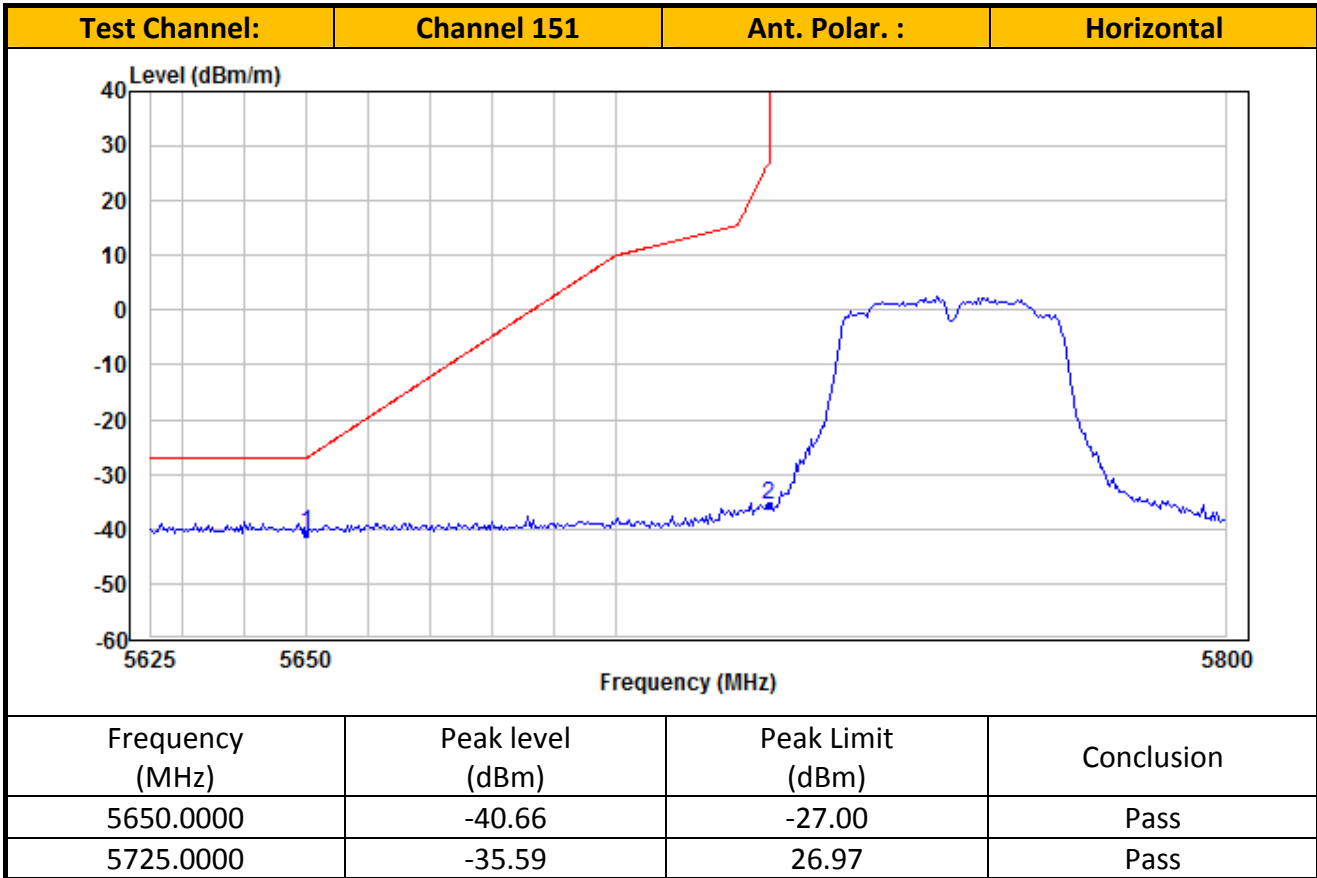

TEST REPORT

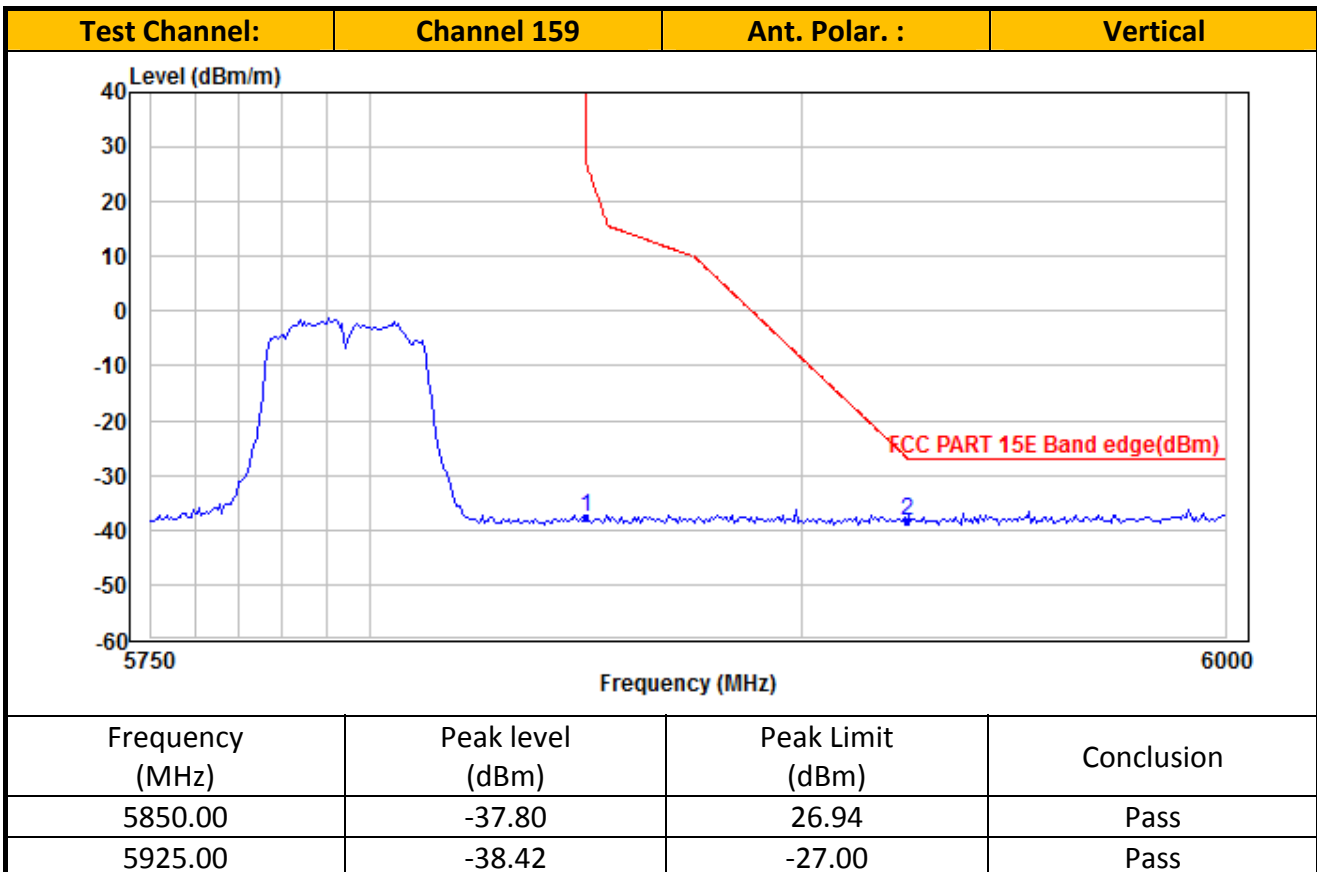
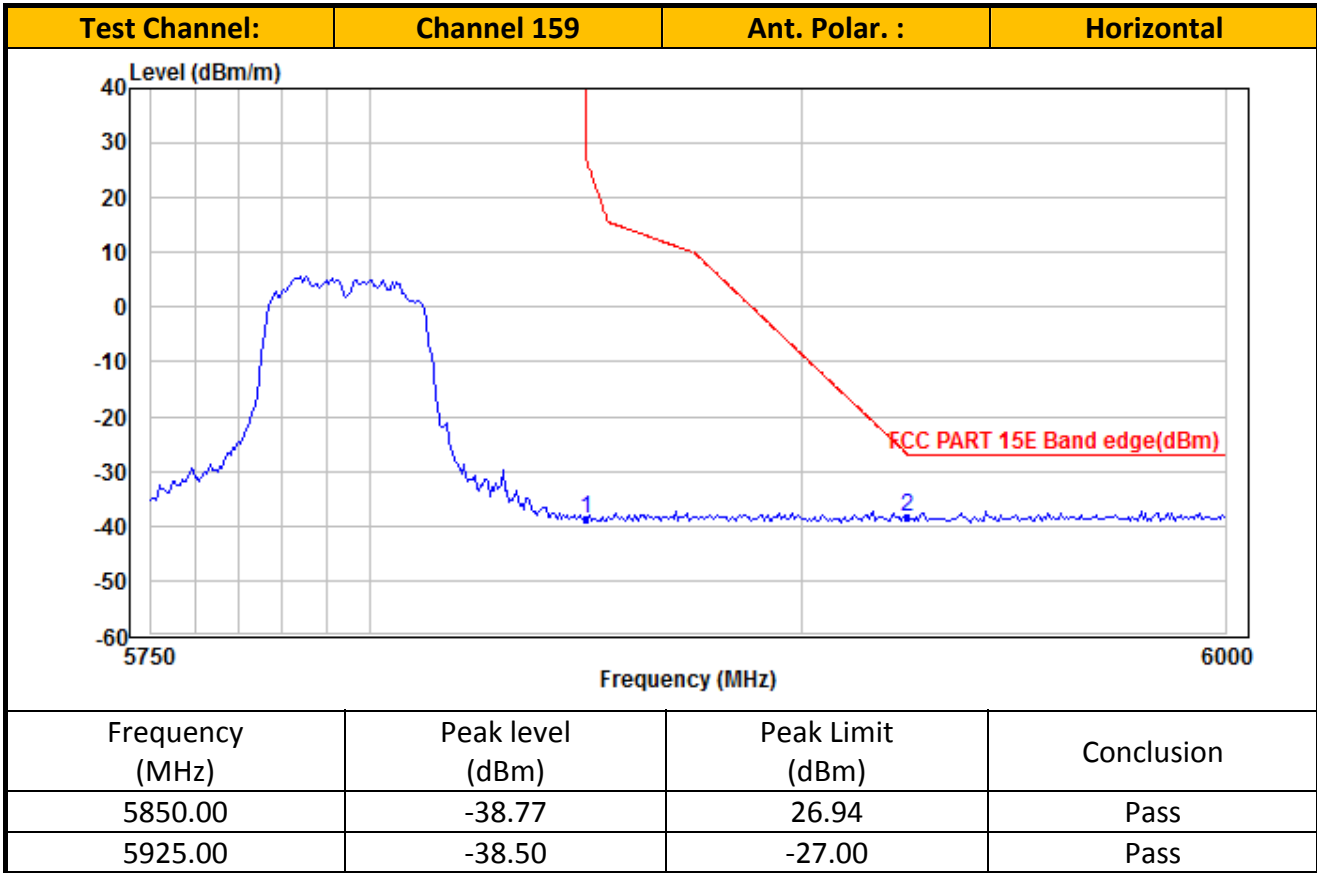

TEST REPORT

Ant. 2_ IEEE 802.11ac (40MHz) (MCS0)

IEEE 802.11ac-VHT40_Channel 38

No.	Frequency (MHz)	Reading (dBuV/m)	Correction factor (dB)	Result (dBuV/m)	Limit (dBuV/m)	Margin (dB)	Detector	Antenna Polaxis
1	10380.00	41.49	11.17	52.66	74.00	21.34	Peak	Horizontal
2	10380.00	29.09	11.17	40.26	54.00	13.74	Average	Horizontal
3	15570.00	40.01	10.84	50.85	74.00	23.15	Peak	Horizontal
4	15570.00	27.18	10.84	38.02	54.00	15.98	Average	Horizontal
5	10380.00	38.55	9.41	47.96	74.00	26.04	Peak	Vertical
6	10380.00	27.10	9.41	36.51	54.00	17.49	Average	Vertical
7	15570.00	42.48	11.69	54.17	74.00	19.83	Peak	Vertical
8	15570.00	26.80	11.69	38.49	54.00	15.51	Average	Vertical

IEEE 802.11ac-VHT40_Channel 46

No.	Frequency (MHz)	Reading (dBuV/m)	Correction factor (dB)	Result (dBuV/m)	Limit (dBuV/m)	Margin (dB)	Detector	Antenna Polaxis
1	10460.00	40.97	11.35	52.32	74.00	21.68	Peak	Horizontal
2	10460.00	28.73	11.35	40.08	54.00	13.92	Average	Horizontal
3	15690.00	43.26	11.03	54.29	74.00	19.71	Peak	Horizontal
4	15690.00	29.15	11.03	40.18	54.00	13.82	Average	Horizontal
5	10460.00	39.00	9.43	48.43	74.00	25.57	Peak	Vertical
6	10460.00	27.54	9.43	36.97	54.00	17.03	Average	Vertical
7	15690.00	43.16	11.98	55.14	74.00	18.86	Peak	Vertical
8	15690.00	28.25	11.98	40.23	54.00	13.77	Average	Vertical

IEEE 802.11ac-VHT40_Channel 54

No.	Frequency (MHz)	Reading (dBuV/m)	Correction factor (dB)	Result (dBuV/m)	Limit (dBuV/m)	Margin (dB)	Detector	Antenna Polaxis
1	10540.00	40.90	11.41	52.31	74.00	21.69	Peak	Horizontal
2	10540.00	28.59	11.41	40.00	54.00	14.00	Average	Horizontal
3	15810.00	41.61	11.21	52.82	74.00	21.18	Peak	Horizontal
4	15810.00	25.92	11.21	37.13	54.00	16.87	Average	Horizontal
5	10540.00	39.22	9.42	48.64	74.00	25.36	Peak	Vertical
6	10540.00	27.09	9.42	36.51	54.00	17.49	Average	Vertical
7	15810.00	44.47	12.26	56.73	74.00	17.27	Peak	Vertical
8	15810.00	30.01	12.26	42.27	54.00	11.73	Average	Vertical

TEST REPORT

IEEE 802.11ac-VHT40_Channel 62

No.	Frequency (MHz)	Reading (dBuV/m)	Correction factor (dB)	Result (dBuV/m)	Limit (dBuV/m)	Margin (dB)	Detector	Antenna Polaxis
1	10620.00	40.77	11.30	52.07	74.00	21.93	Peak	Horizontal
2	10620.00	28.46	11.30	39.76	54.00	14.24	Average	Horizontal
3	15930.00	38.49	11.41	49.90	74.00	24.10	Peak	Horizontal
4	15930.00	25.44	11.41	36.85	54.00	17.15	Average	Horizontal
5	10620.00	39.91	9.35	49.26	74.00	24.74	Peak	Vertical
6	10620.00	26.85	9.35	36.20	54.00	17.80	Average	Vertical
7	15930.00	41.04	12.56	53.60	74.00	20.40	Peak	Vertical
8	15930.00	25.75	12.56	38.31	54.00	15.69	Average	Vertical

IEEE 802.11ac-VHT40_Channel 102

No.	Frequency (MHz)	Reading (dBuV/m)	Correction factor (dB)	Result (dBuV/m)	Limit (dBuV/m)	Margin (dB)	Detector	Antenna Polaxis
1	11020.00	41.10	10.24	51.34	74.00	22.66	Peak	Horizontal
2	11020.00	28.84	10.24	39.08	54.00	14.92	Average	Horizontal
3	16530.00	37.29	13.34	50.63	74.00	23.37	Peak	Horizontal
4	16530.00	25.19	13.34	38.53	54.00	15.47	Average	Horizontal
5	11020.00	41.27	8.45	49.72	74.00	24.28	Peak	Vertical
6	11020.00	28.40	8.45	36.85	54.00	17.15	Average	Vertical
7	16530.00	42.40	13.40	55.80	74.00	18.20	Peak	Vertical
8	16530.00	25.92	13.40	39.32	54.00	14.68	Average	Vertical

IEEE 802.11ac-VHT40_Channel 110

No.	Frequency (MHz)	Reading (dBuV/m)	Correction factor (dB)	Result (dBuV/m)	Limit (dBuV/m)	Margin (dB)	Detector	Antenna Polaxis
1	11100.00	41.59	10.00	51.59	74.00	22.41	Peak	Horizontal
2	11100.00	28.29	10.00	38.29	54.00	15.71	Average	Horizontal
3	16650.00	38.60	13.29	51.89	74.00	22.11	Peak	Horizontal
4	16650.00	25.92	13.29	39.21	54.00	14.79	Average	Horizontal
5	11100.00	39.36	8.26	47.62	74.00	26.38	Peak	Vertical
6	11100.00	27.61	8.26	35.87	54.00	18.13	Average	Vertical
7	16650.00	36.77	13.18	49.95	74.00	24.05	Peak	Vertical
8	16650.00	25.10	13.18	38.28	54.00	15.72	Average	Vertical

TEST REPORT

IEEE 802.11ac-VHT40_Channel 134

No.	Frequency (MHz)	Reading (dBuV/m)	Correction factor (dB)	Result (dBuV/m)	Limit (dBuV/m)	Margin (dB)	Detector	Antenna Polaxis
1	11340.00	40.35	9.89	50.24	74.00	23.76	Peak	Horizontal
2	11340.00	28.63	9.89	38.52	54.00	15.48	Average	Horizontal
3	17010.00	37.30	13.18	50.48	74.00	23.52	Peak	Horizontal
4	17010.00	25.32	13.18	38.50	54.00	15.50	Average	Horizontal
5	11340.00	40.60	8.29	48.89	74.00	25.11	Peak	Vertical
6	11340.00	28.52	8.29	36.81	54.00	17.19	Average	Vertical
7	17010.00	41.46	12.57	54.03	74.00	19.97	Peak	Vertical
8	17010.00	23.99	12.57	36.56	54.00	17.44	Average	Vertical

IEEE 802.11ac-VHT40_Channel 151

No.	Frequency (MHz)	Reading (dBuV/m)	Correction factor (dB)	Result (dBuV/m)	Limit (dBuV/m)	Margin (dB)	Detector	Antenna Polaxis
1	11510.00	40.52	9.79	50.31	74.00	23.69	Peak	Horizontal
2	11510.00	28.89	9.79	38.68	54.00	15.32	Average	Horizontal
3	17265.00	38.31	14.11	52.42	74.00	21.58	Peak	Horizontal
4	17265.00	25.43	14.11	39.54	54.00	14.46	Average	Horizontal
5	11510.00	40.37	8.30	48.67	74.00	25.33	Peak	Vertical
6	11510.00	29.03	8.30	37.33	54.00	16.67	Average	Vertical
7	17265.00	37.34	13.35	50.69	74.00	23.31	Peak	Vertical
8	17265.00	25.01	13.35	38.36	54.00	15.64	Average	Vertical

IEEE 802.11ac-VHT40_Channel 159

No.	Frequency (MHz)	Reading (dBuV/m)	Correction factor (dB)	Result (dBuV/m)	Limit (dBuV/m)	Margin (dB)	Detector	Antenna Polaxis
1	11590.00	41.80	9.87	51.67	74.00	22.33	Peak	Horizontal
2	11590.00	28.31	9.87	38.18	54.00	15.82	Average	Horizontal
3	17385.00	40.04	14.62	54.66	74.00	19.34	Peak	Horizontal
4	17385.00	27.35	14.62	41.97	54.00	12.03	Average	Horizontal
5	11590.00	40.67	8.52	49.19	74.00	24.81	Peak	Vertical
6	11590.00	28.19	8.52	36.71	54.00	17.29	Average	Vertical
7	17385.00	40.32	13.79	54.11	74.00	19.89	Peak	Vertical
8	17385.00	27.23	13.79	41.02	54.00	12.98	Average	Vertical

TEST REPORT

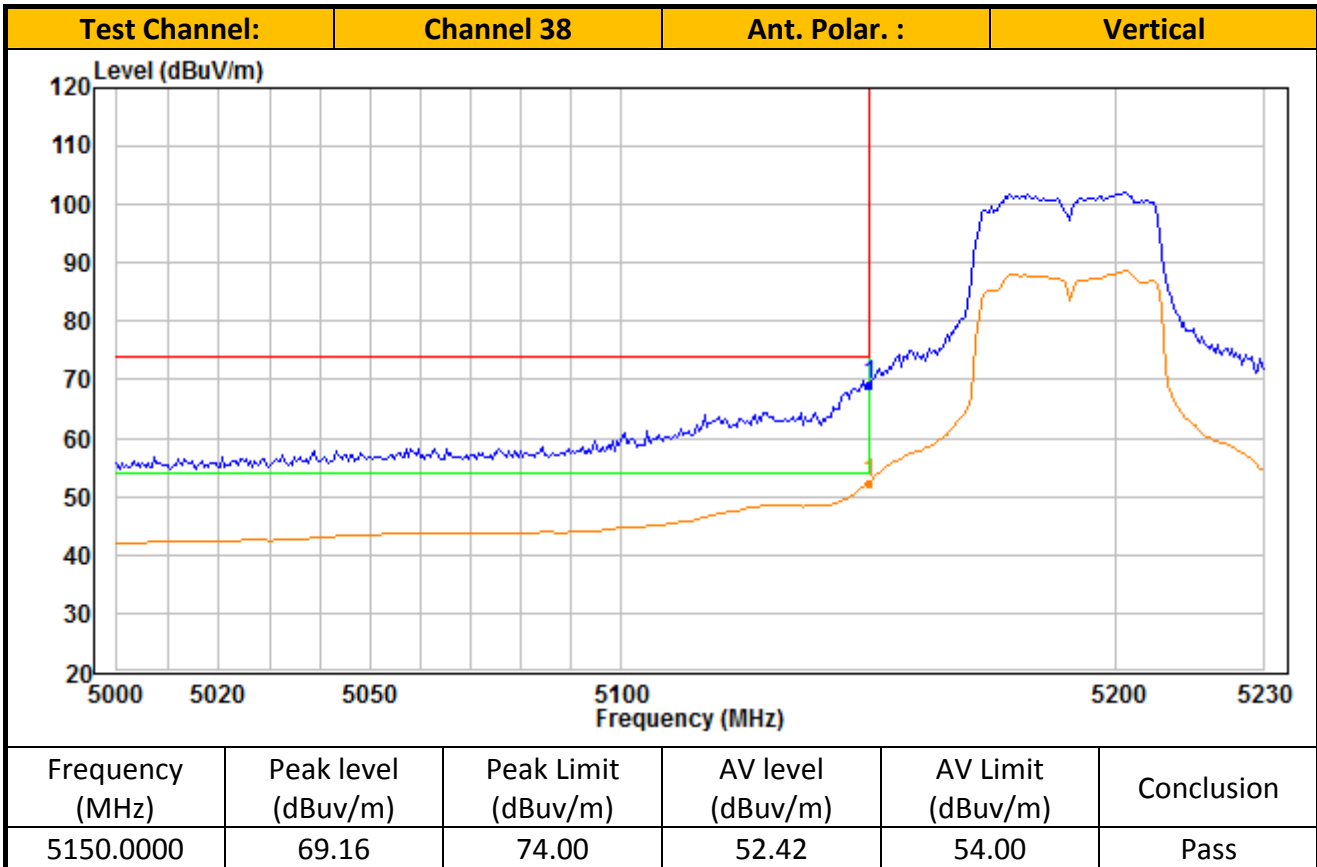
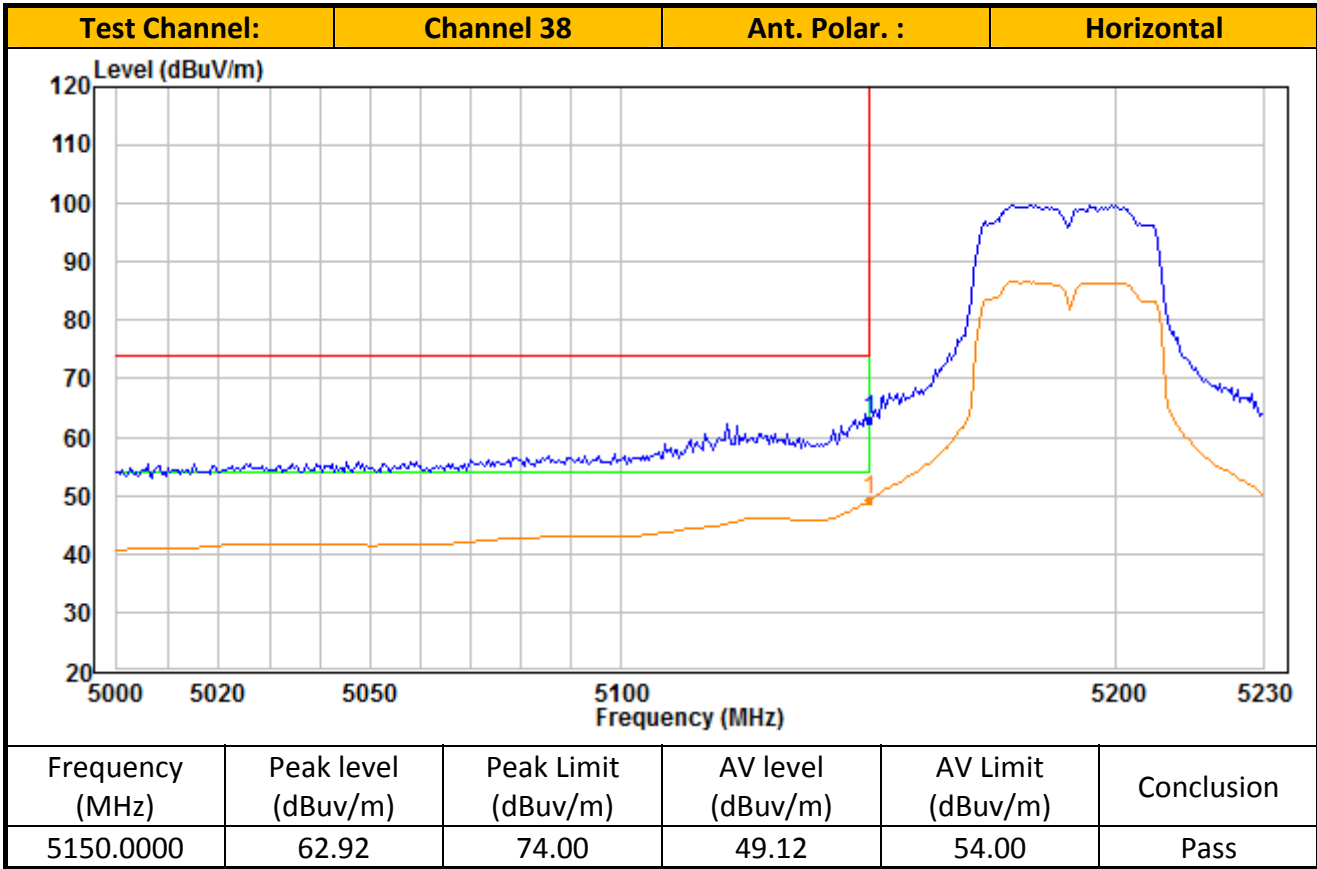

TEST REPORT

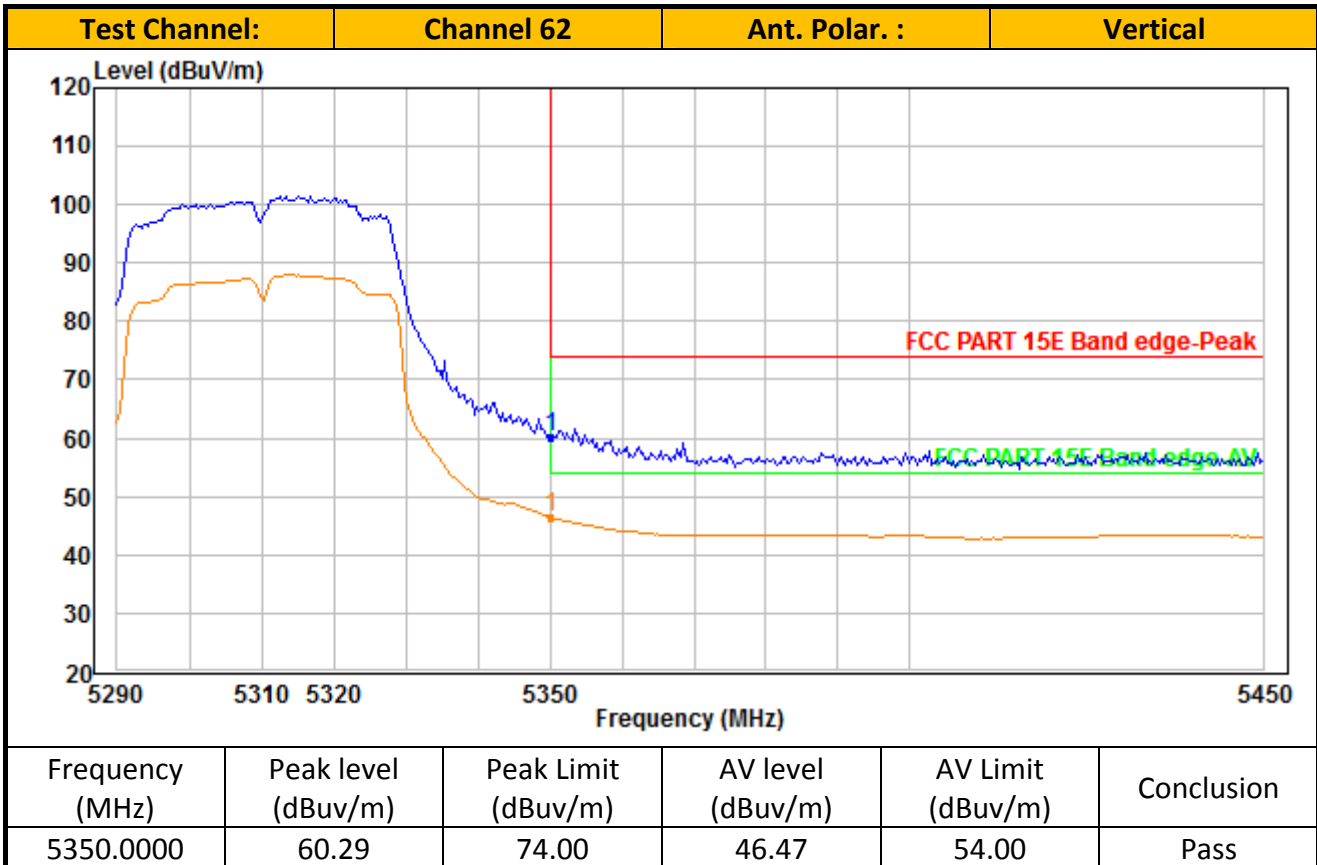
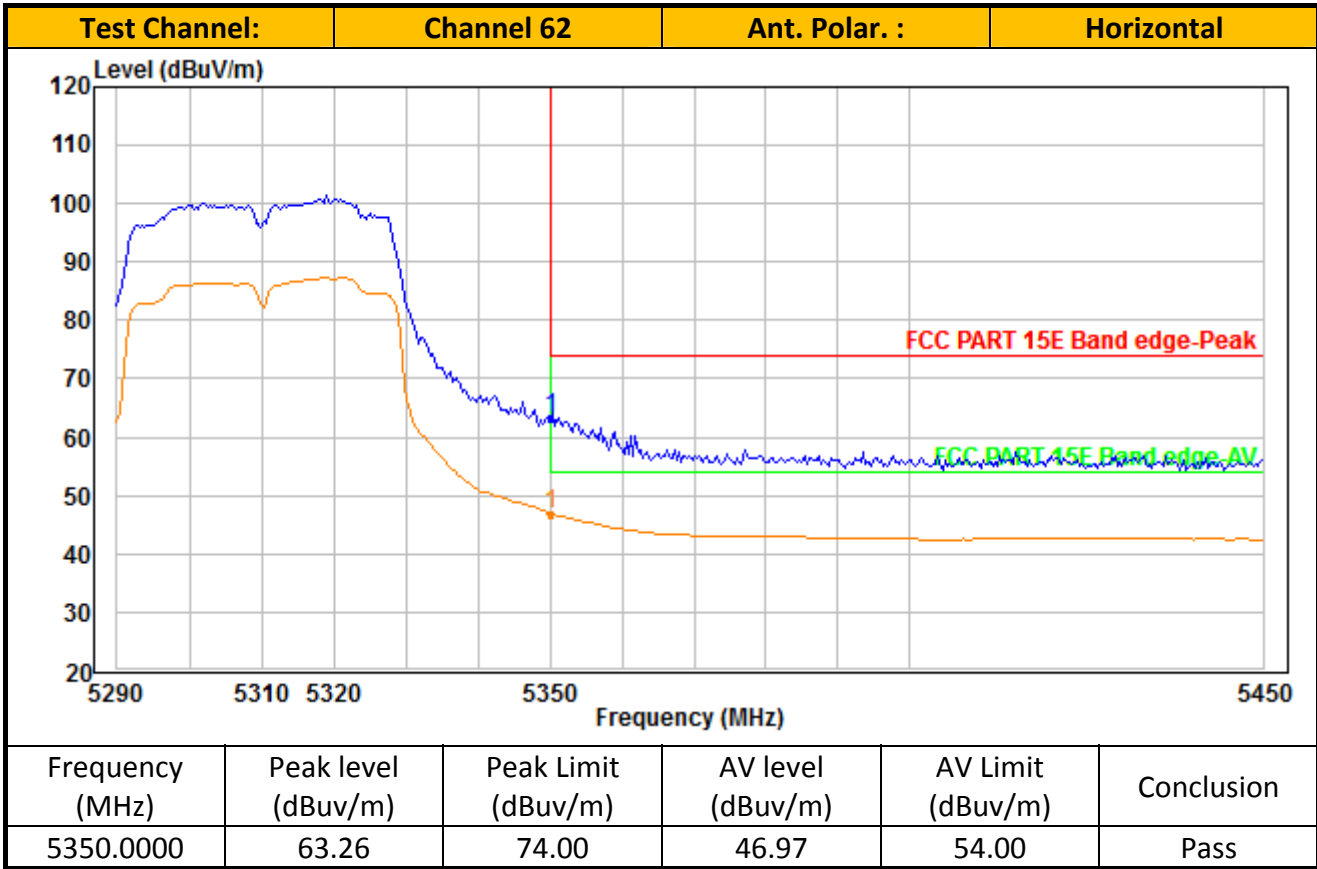

TEST REPORT

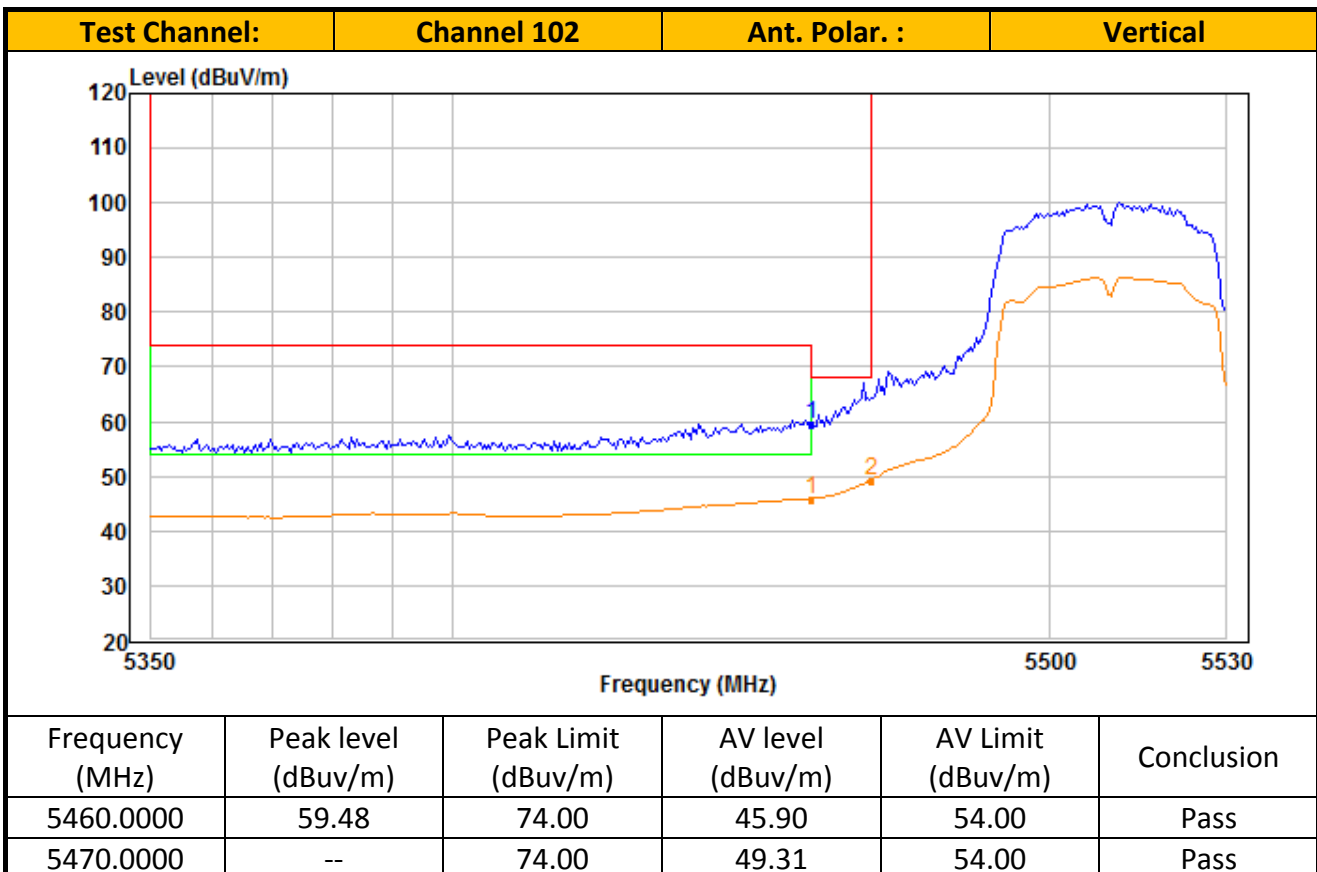
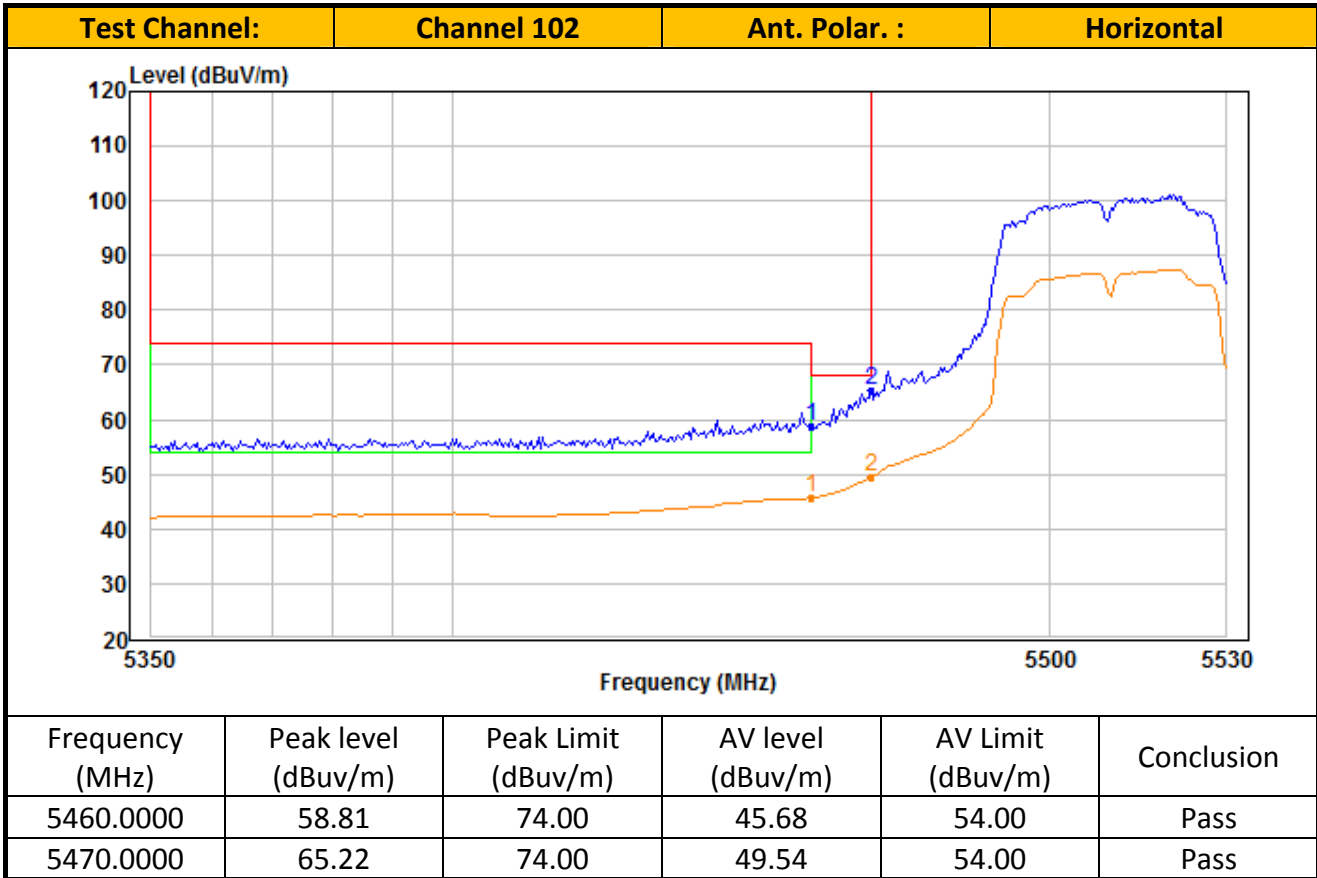

TEST REPORT

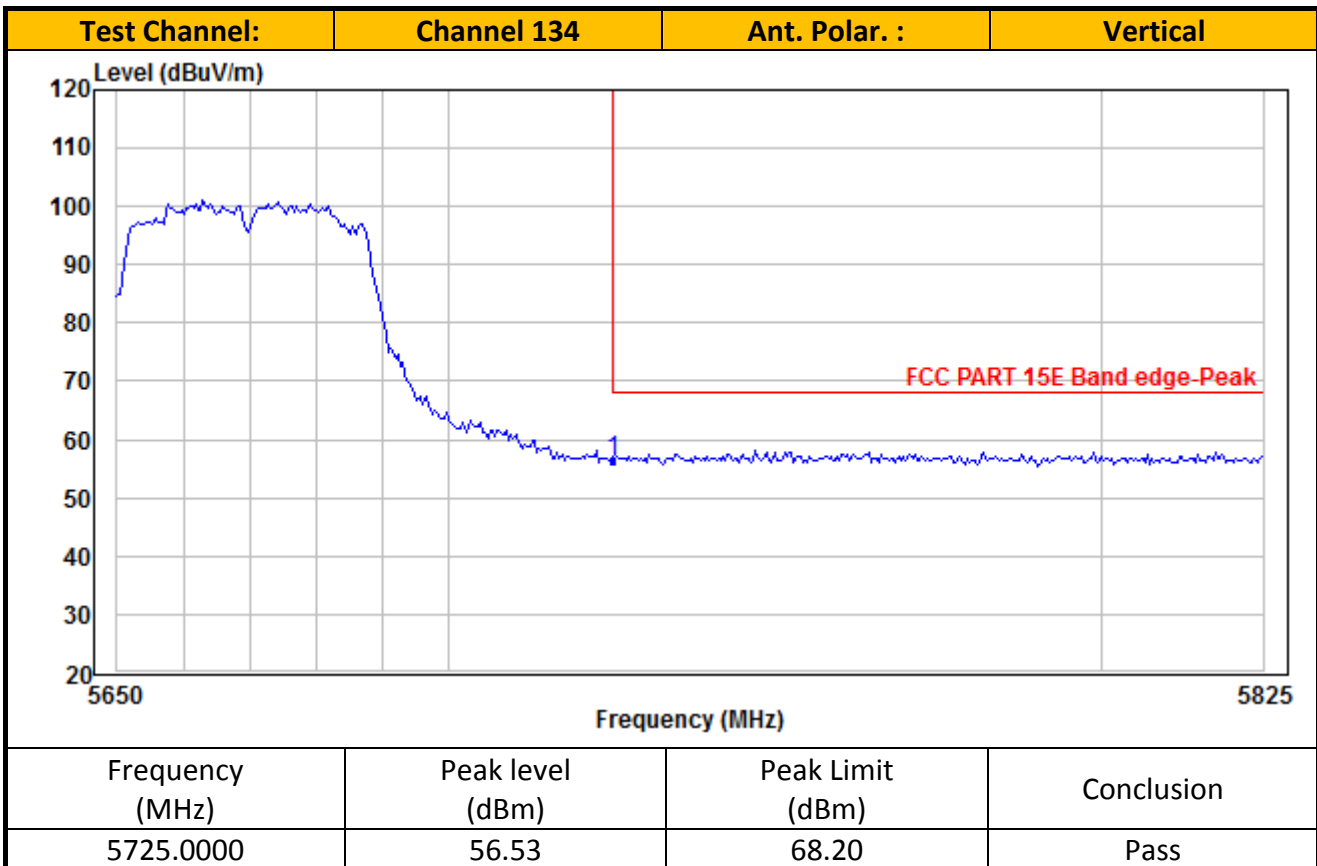
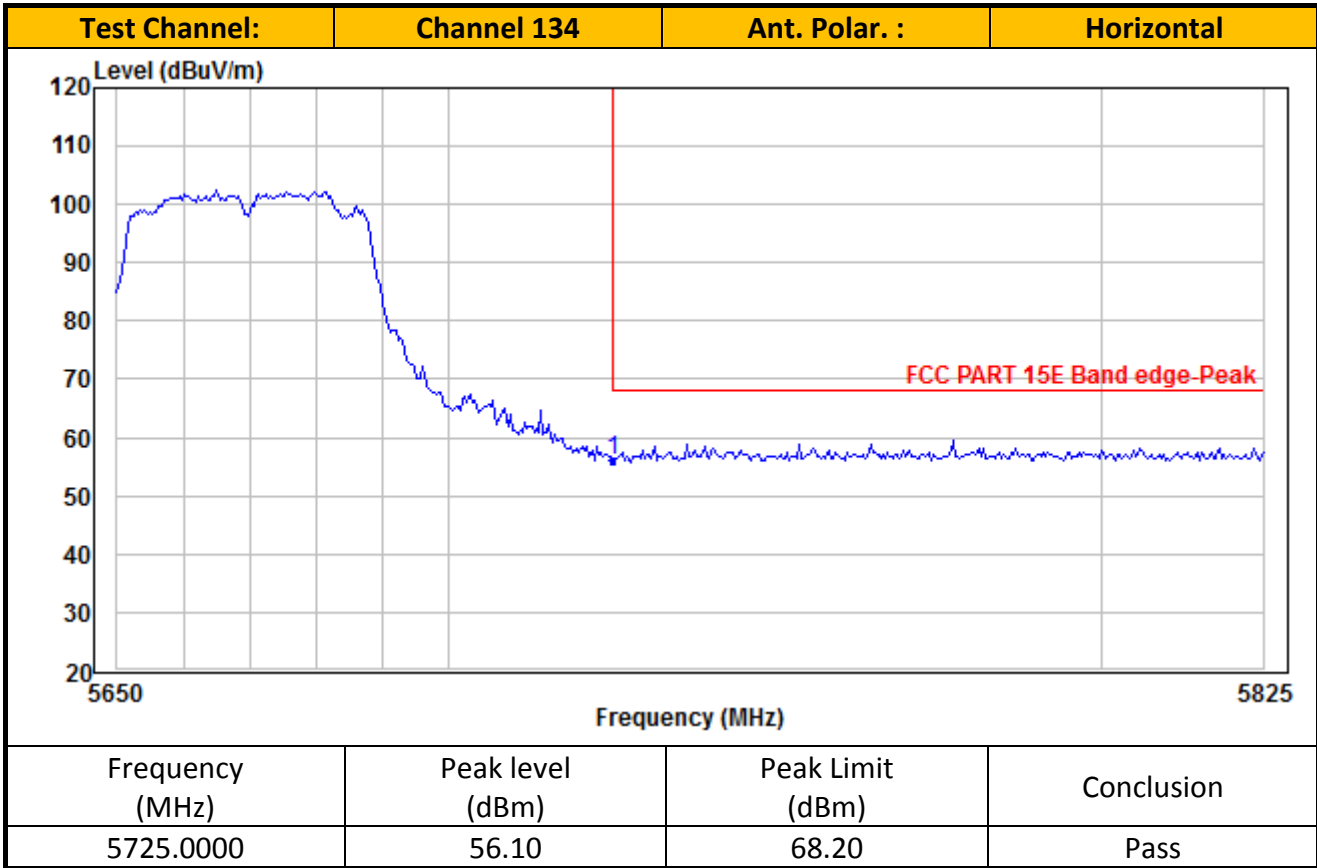

TEST REPORT

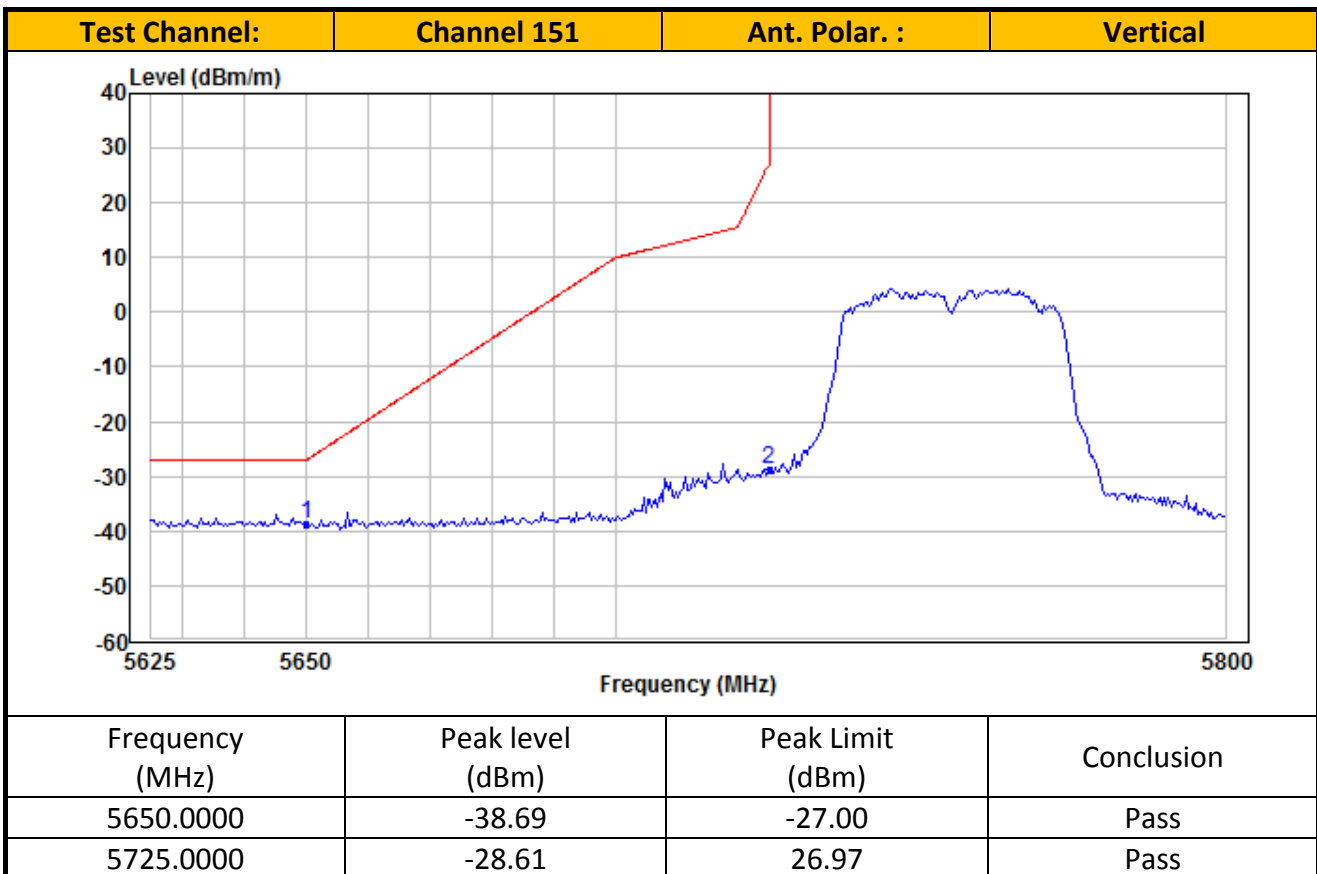
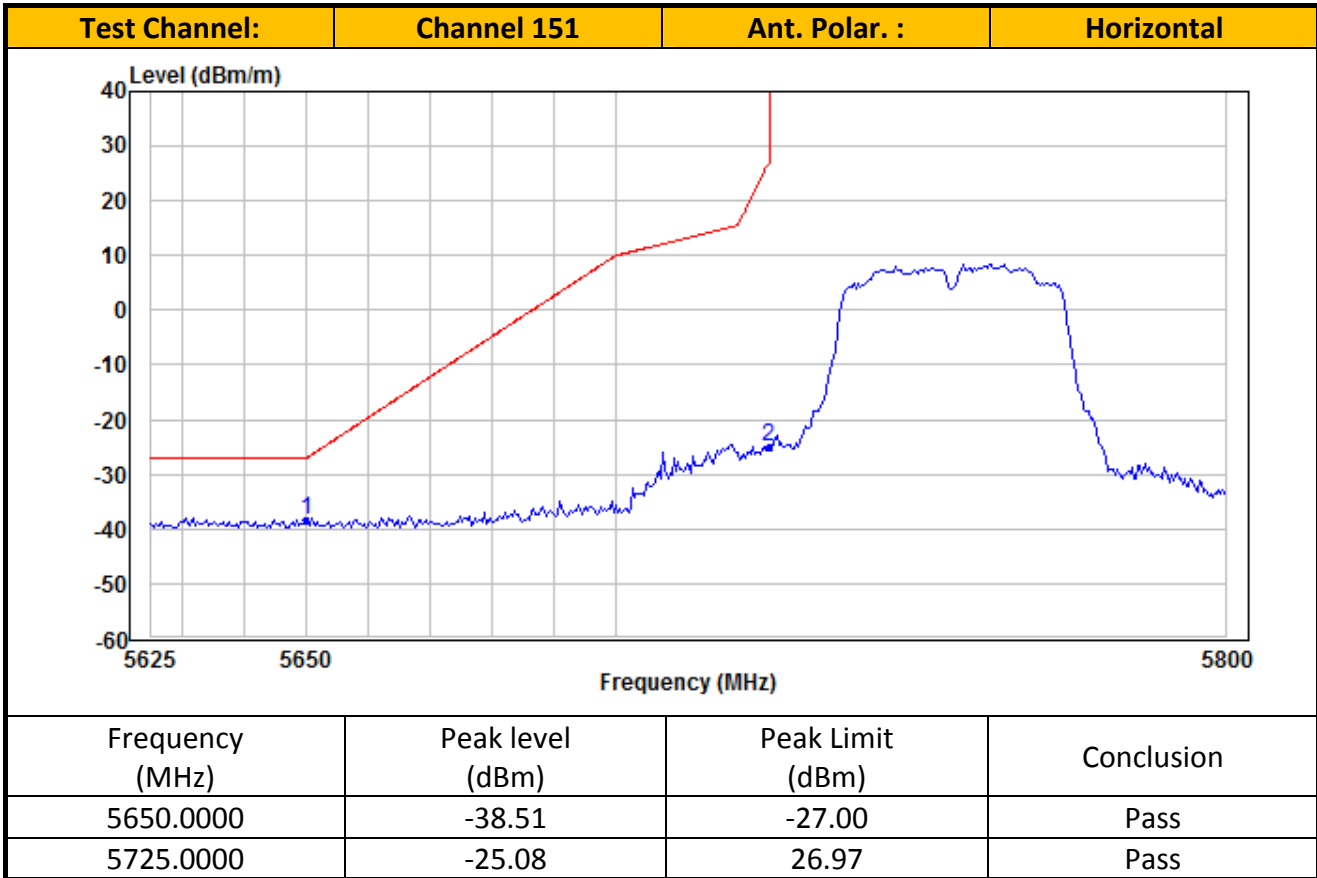

TEST REPORT

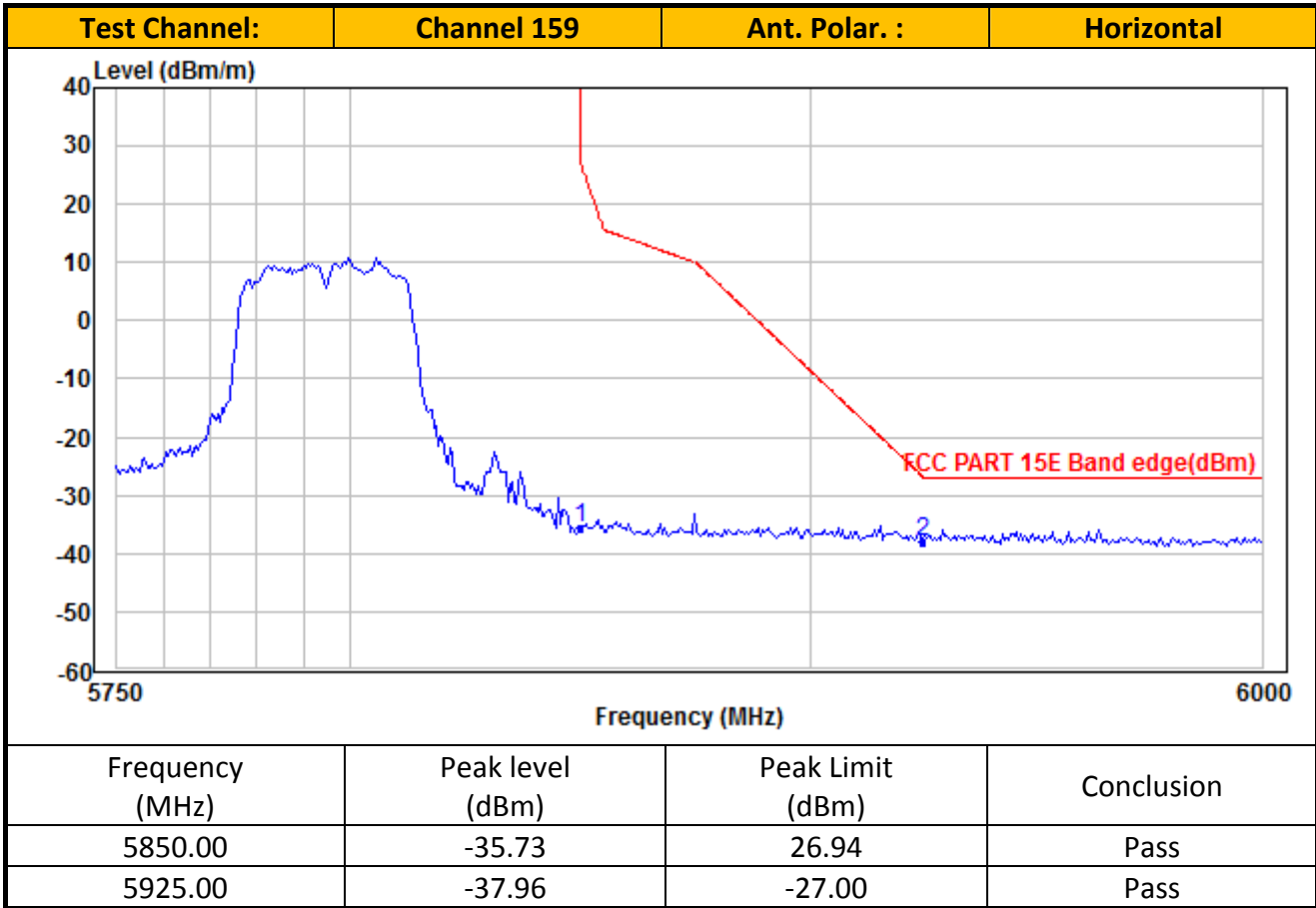

TEST REPORT

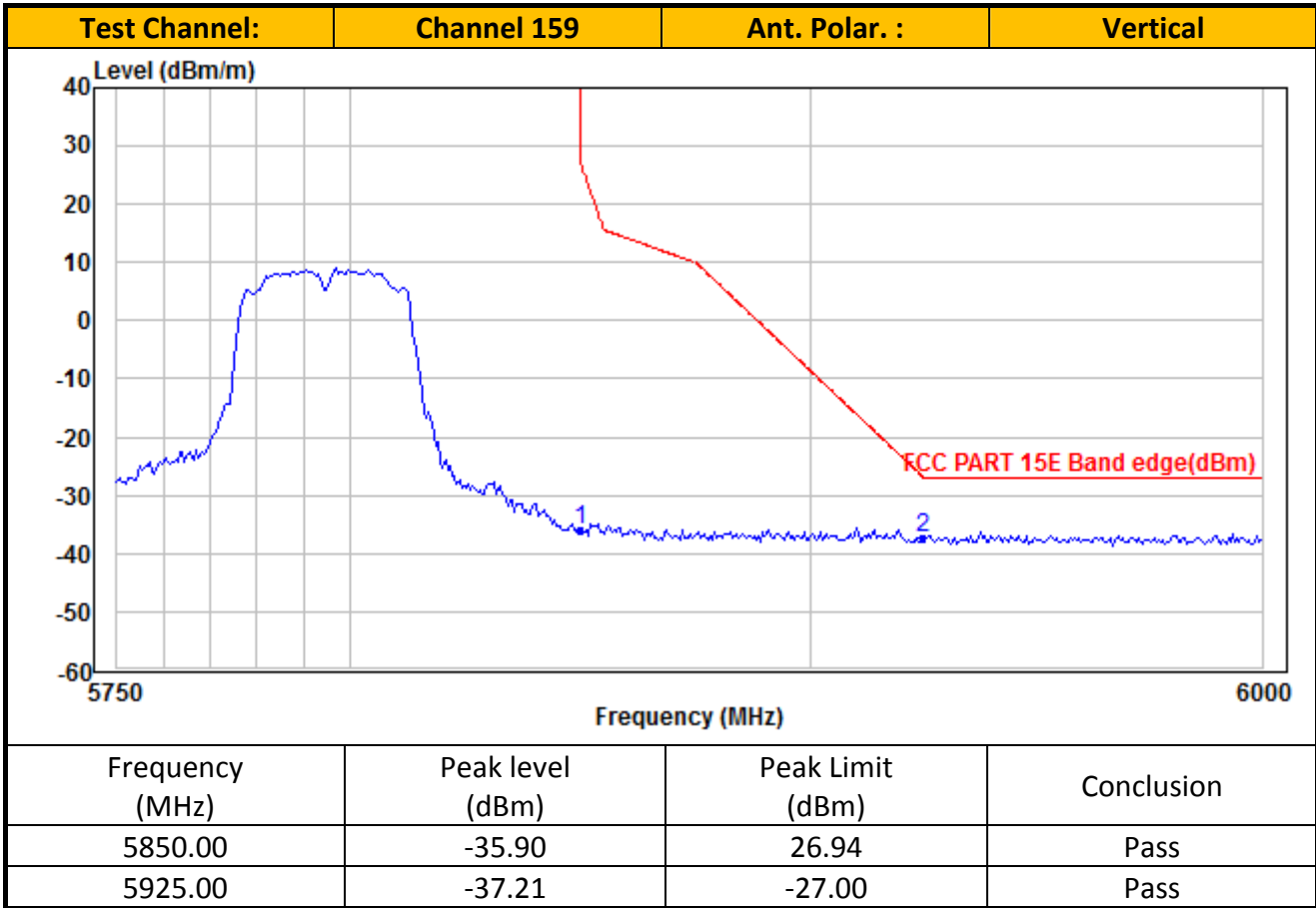

- NOTES:
1. Peak detector is used for the emission measurement.
 2. Average detector is used for the average data of emission measurement
 3. All measurements were made at 3 meters. Radiated emissions not detected at the 3-meter distance were measured at 0.3-meter and an inverse proportional extrapolation was performed to compare the signal level to the 3-meter limit. No other radiated emissions than those reported were detected at a test distance of 0.3-meter.
 4. Value in the margin column shows emission below limit.
 5. Horn antenna is used for the emission over 1000MHz.
 6. Emission (the row indicated by ***bold italic***) within the restricted band meets the requirement of FCC Part 15 Section 15.205.
 7. For the measurement of radiated emission, summation method was used which numerical integrating (in terms of linear power) over the transmitter occupied bandwidth.
 8. For the linear power measurement, data in 1MHz spacing was collected by spectrum analyzer with 1MHz resolution bandwidth.

TEST REPORT

Frequency: 5210MHz
Ant. 1_ IEEE 802.11ac (80MHz) (MCS0)

IEEE 802.11ac-VHT80_Channel 42

No.	Frequency (MHz)	Reading (dBuV/m)	Correction factor (dB)	Result (dBuV/m)	Limit (dBuV/m)	Margin (dB)	Detector	Antenna Polaxis
1	10460.00	40.96	11.35	52.31	74.00	21.69	Peak	Horizontal
2	10460.00	29.01	11.35	40.36	54.00	13.64	Average	Horizontal
3	15690.00	37.94	11.03	48.97	74.00	25.03	Peak	Horizontal
4	15690.00	26.13	11.03	37.16	54.00	16.84	Average	Horizontal
5	10460.00	39.79	9.43	49.22	74.00	24.78	Peak	Vertical
6	10460.00	27.95	9.43	37.38	54.00	16.62	Average	Vertical
7	15690.00	38.83	11.98	50.81	74.00	23.19	Peak	Vertical
8	15690.00	26.40	11.98	38.38	54.00	15.62	Average	Vertical

IEEE 802.11ac-VHT80_Channel 58

No.	Frequency (MHz)	Reading (dBuV/m)	Correction factor (dB)	Result (dBuV/m)	Limit (dBuV/m)	Margin (dB)	Detector	Antenna Polaxis
1	10580.00	40.45	11.36	51.81	74.00	22.19	Peak	Horizontal
2	10580.00	28.53	11.36	39.89	54.00	14.11	Average	Horizontal
3	15870.00	41.79	11.29	53.08	74.00	20.92	Peak	Horizontal
4	15870.00	26.13	11.29	37.42	54.00	16.58	Average	Horizontal
5	10580.00	39.86	9.39	49.25	74.00	24.75	Peak	Vertical
6	10580.00	27.43	9.39	36.82	54.00	17.18	Average	Vertical
7	15870.00	38.87	12.38	51.25	74.00	22.75	Peak	Vertical
8	15870.00	25.90	12.38	38.28	54.00	15.72	Average	Vertical

IEEE 802.11ac-VHT80_Channel 106

No.	Frequency (MHz)	Reading (dBuV/m)	Correction factor (dB)	Result (dBuV/m)	Limit (dBuV/m)	Margin (dB)	Detector	Antenna Polaxis
1	11060.00	40.54	10.12	50.66	74.00	23.34	Peak	Horizontal
2	11060.00	28.77	10.12	38.89	54.00	15.11	Average	Horizontal
3	16590.00	36.28	13.31	49.59	74.00	24.41	Peak	Horizontal
4	16590.00	25.18	13.31	38.49	54.00	15.51	Average	Horizontal
5	11060.00	40.17	8.36	48.53	74.00	25.47	Peak	Vertical
6	11060.00	28.17	8.36	36.53	54.00	17.47	Average	Vertical
7	16590.00	37.80	13.29	51.09	74.00	22.91	Peak	Vertical
8	16590.00	24.42	13.29	37.71	54.00	16.29	Average	Vertical

TEST REPORT

IEEE 802.11ac-VHT80_Channel 122

No.	Frequency (MHz)	Reading (dBuV/m)	Correction factor (dB)	Result (dBuV/m)	Limit (dBuV/m)	Margin (dB)	Detector	Antenna Polaxis
1	11220.00	41.65	9.94	51.59	74.00	22.41	Peak	Horizontal
2	11220.00	28.43	9.94	38.37	54.00	15.63	Average	Horizontal
3	16830.00	39.60	13.21	52.81	74.00	21.19	Peak	Horizontal
4	16830.00	27.50	13.21	40.71	54.00	13.29	Average	Horizontal
5	11220.00	39.53	8.27	47.80	74.00	26.20	Peak	Vertical
6	11220.00	27.79	8.27	36.06	54.00	17.94	Average	Vertical
7	16830.00	41.54	12.85	54.39	74.00	19.61	Peak	Vertical
8	16830.00	27.85	12.85	40.70	54.00	13.30	Average	Vertical

IEEE 802.11ac-VHT80_Channel 155

No.	Frequency (MHz)	Reading (dBuV/m)	Correction factor (dB)	Result (dBuV/m)	Limit (dBuV/m)	Margin (dB)	Detector	Antenna Polaxis
1	11550.00	41.96	9.83	51.79	74.00	22.21	Peak	Horizontal
2	11550.00	29.26	9.83	39.09	54.00	14.91	Average	Horizontal
3	17325.00	39.14	14.36	53.50	74.00	20.50	Peak	Horizontal
4	17325.00	27.00	14.36	41.36	54.00	12.64	Average	Horizontal
5	11550.00	41.55	8.41	49.96	74.00	24.04	Peak	Vertical
6	11550.00	29.07	8.41	37.48	54.00	16.52	Average	Vertical
7	17325.00	38.04	13.57	51.61	74.00	22.39	Peak	Vertical
8	17325.00	26.36	13.57	39.93	54.00	14.07	Average	Vertical

TEST REPORT

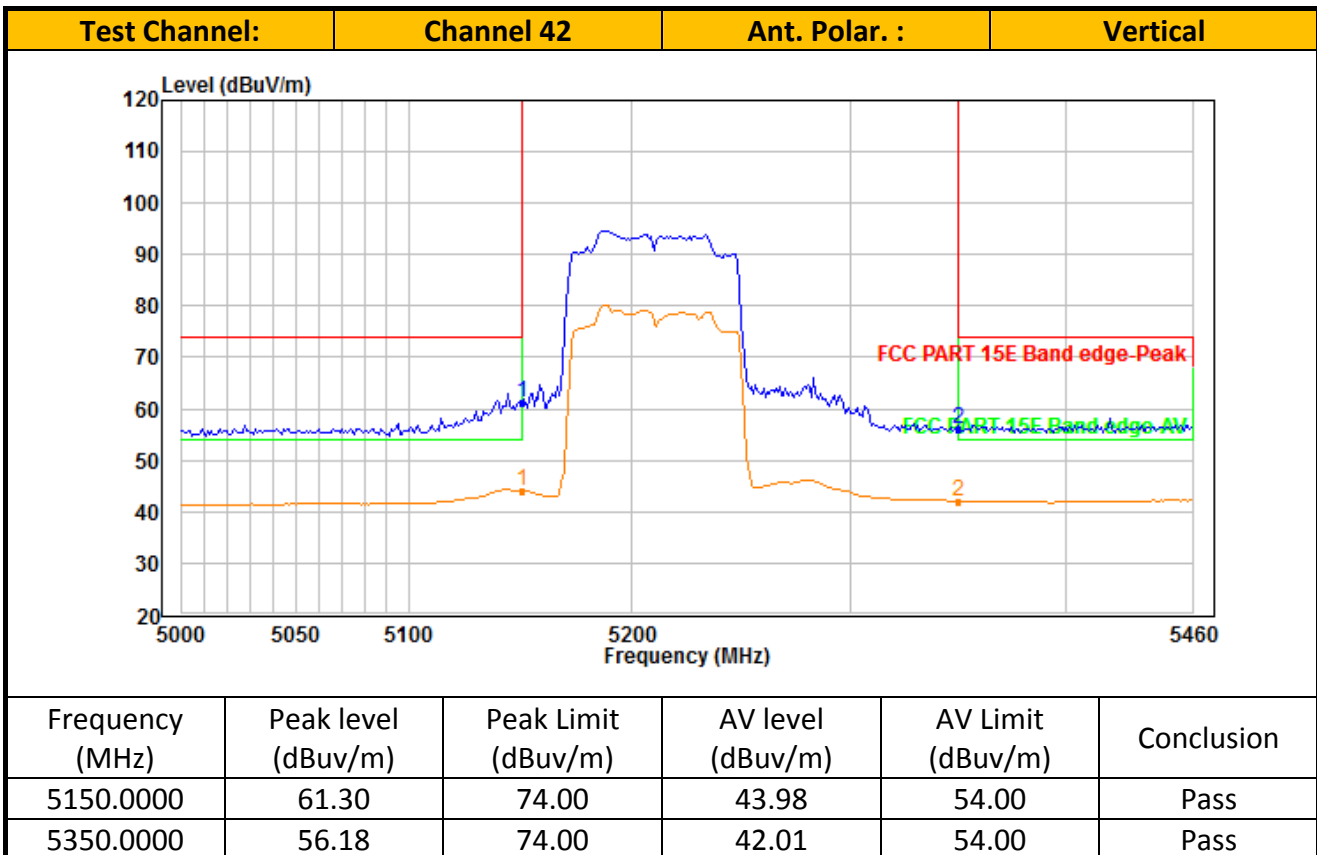
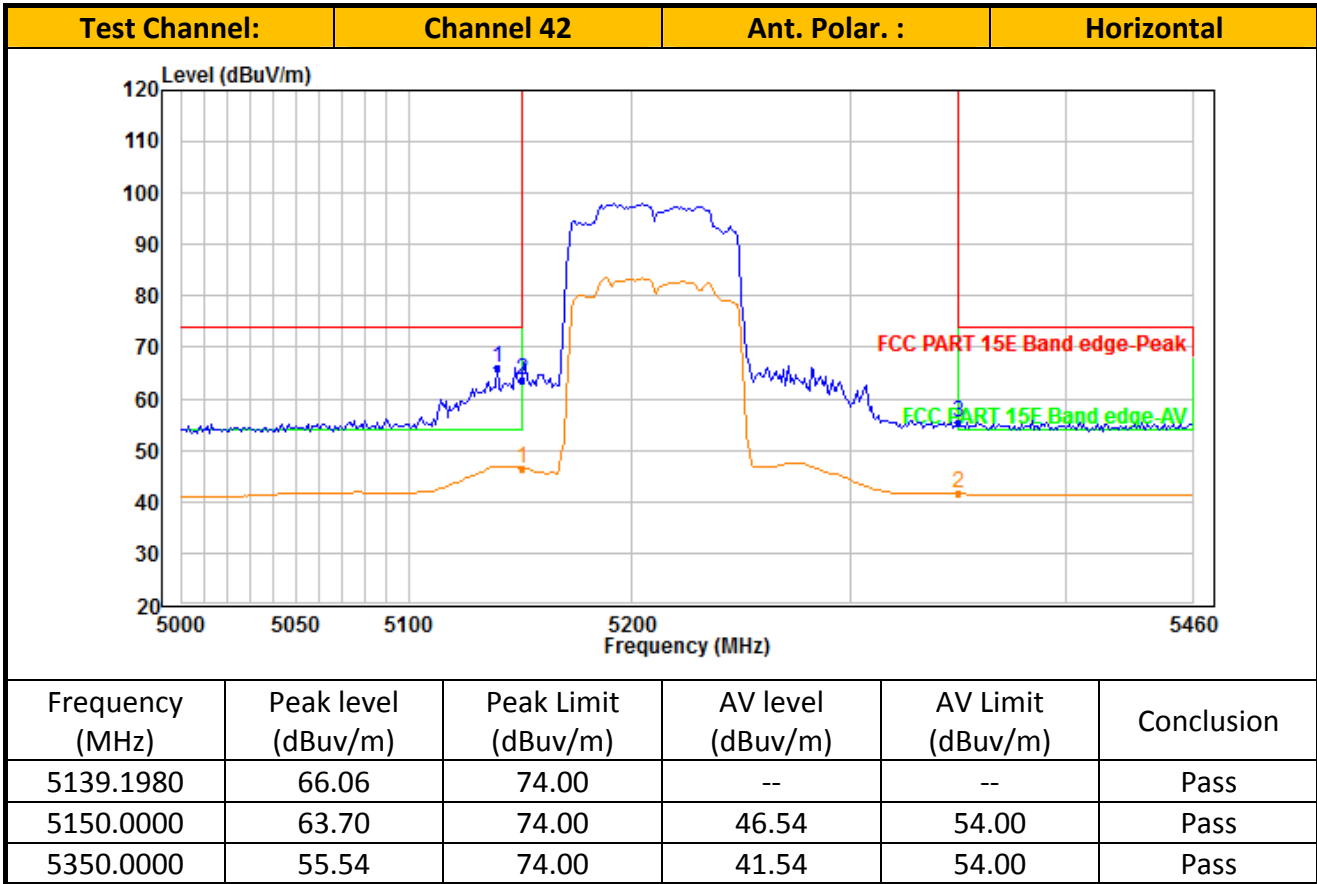

TEST REPORT

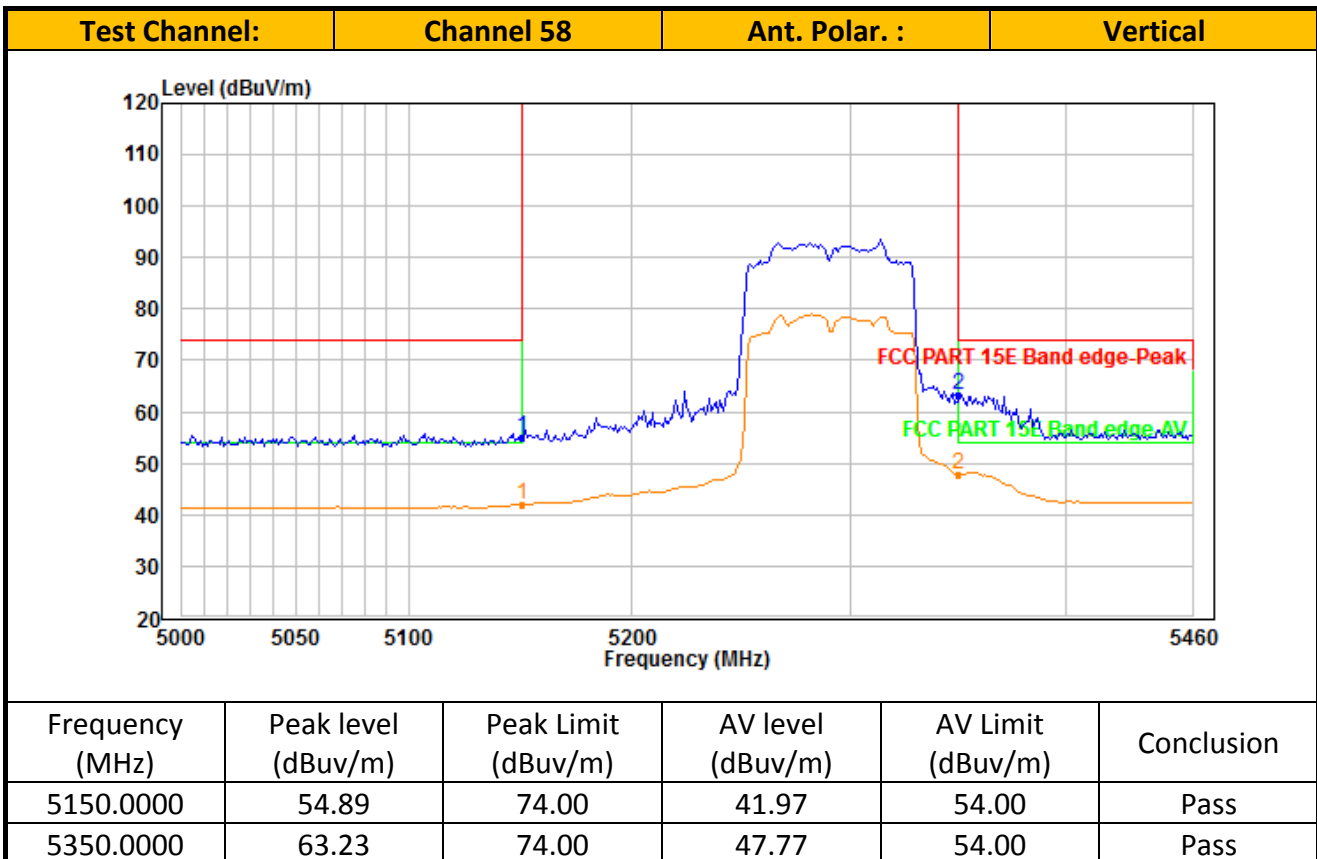
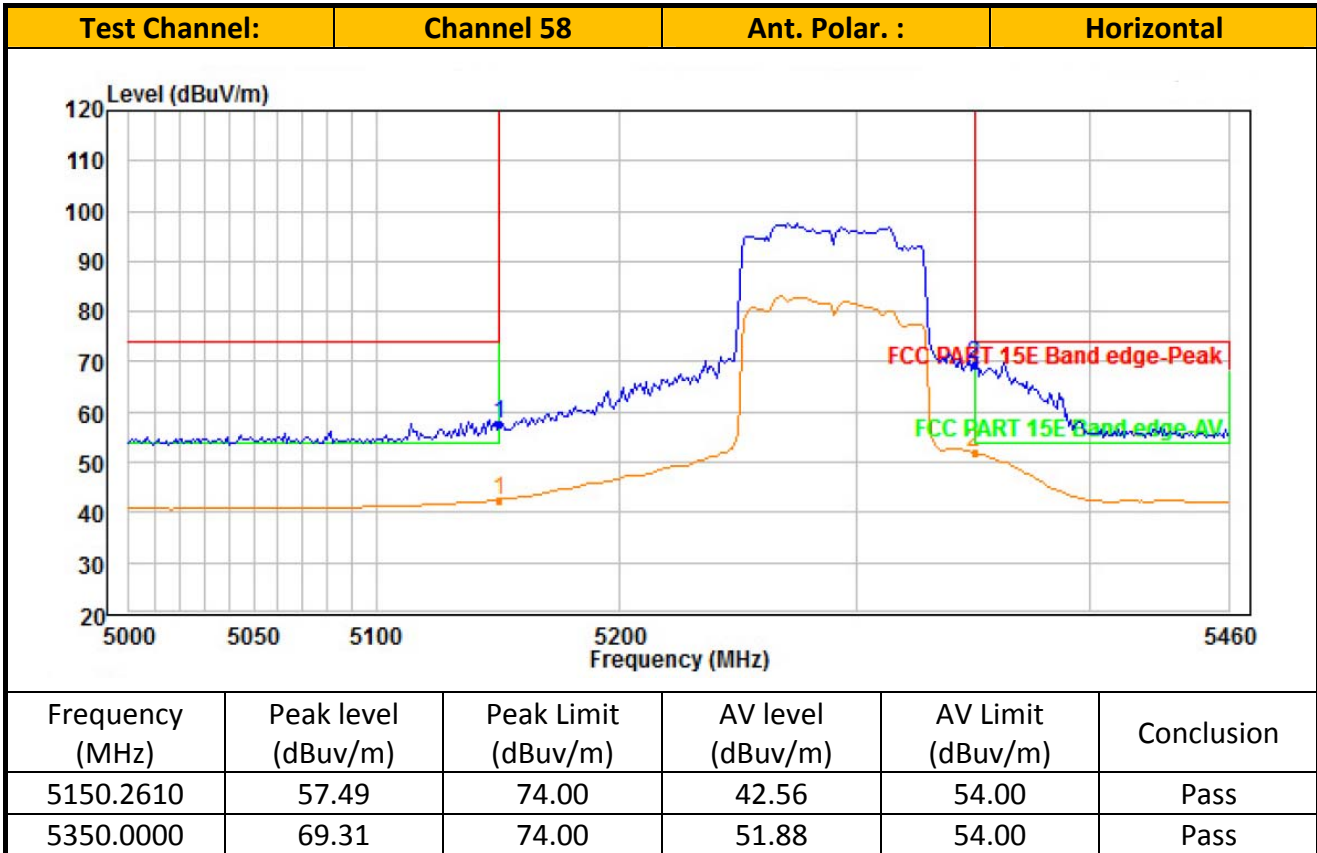

TEST REPORT

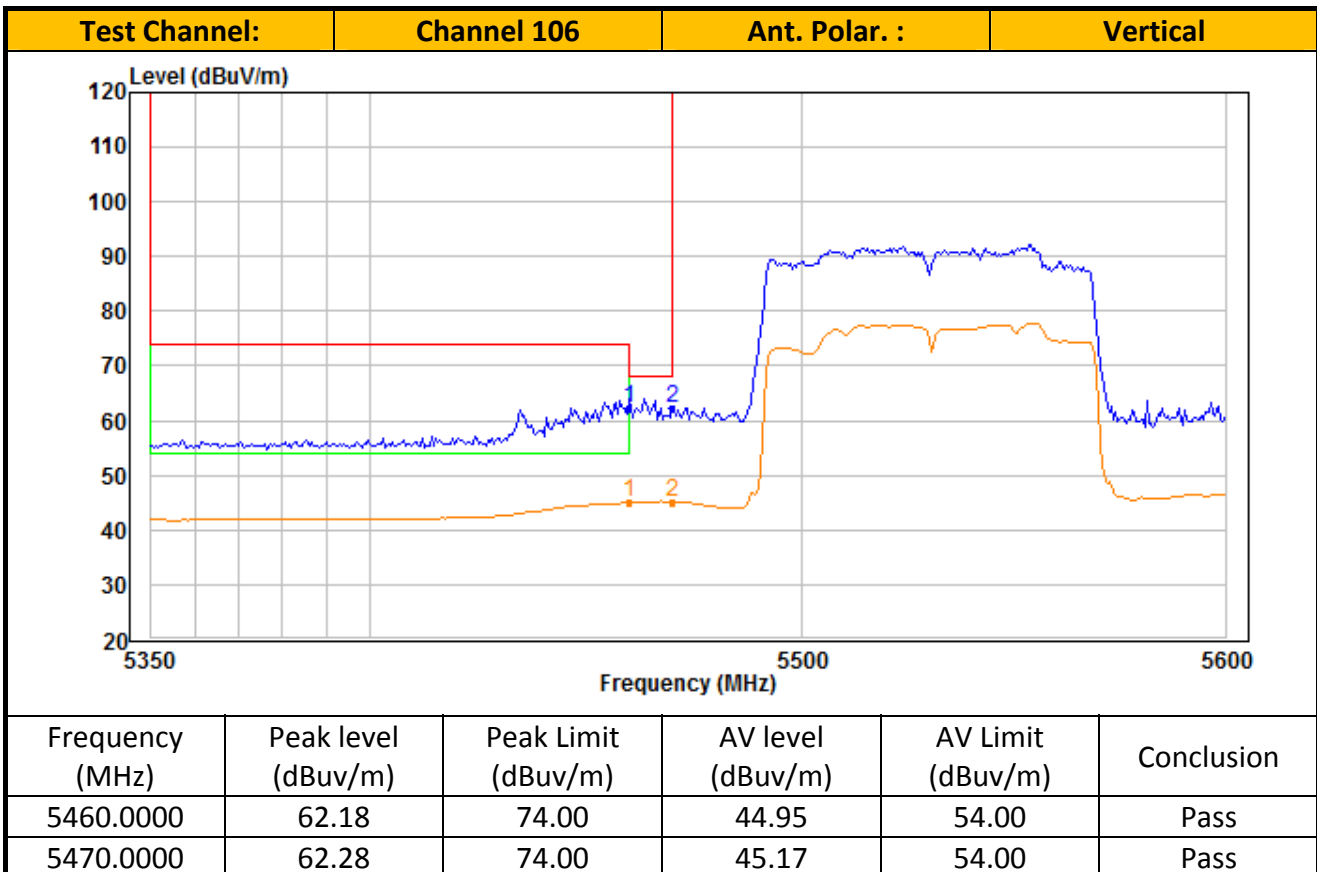
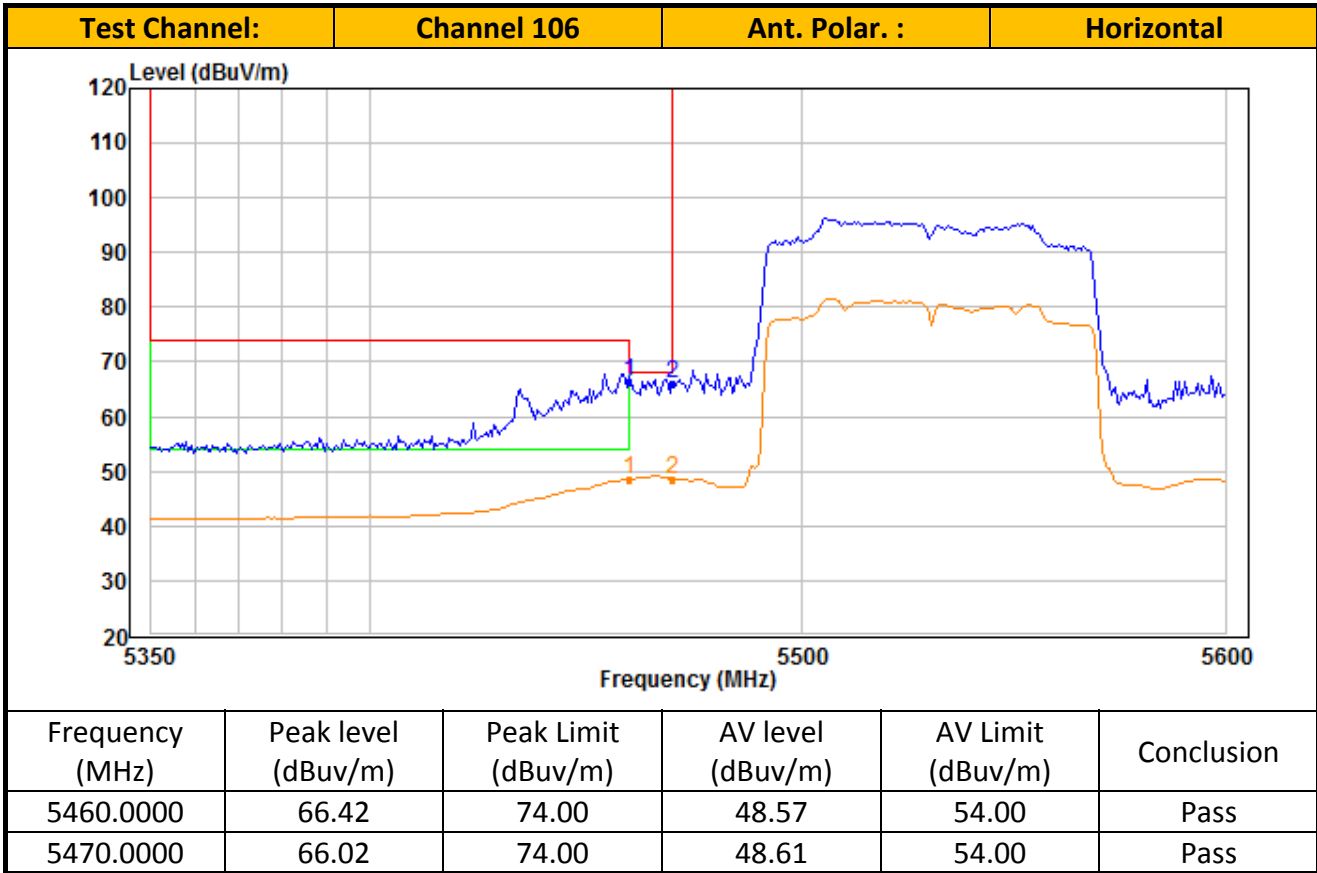

TEST REPORT

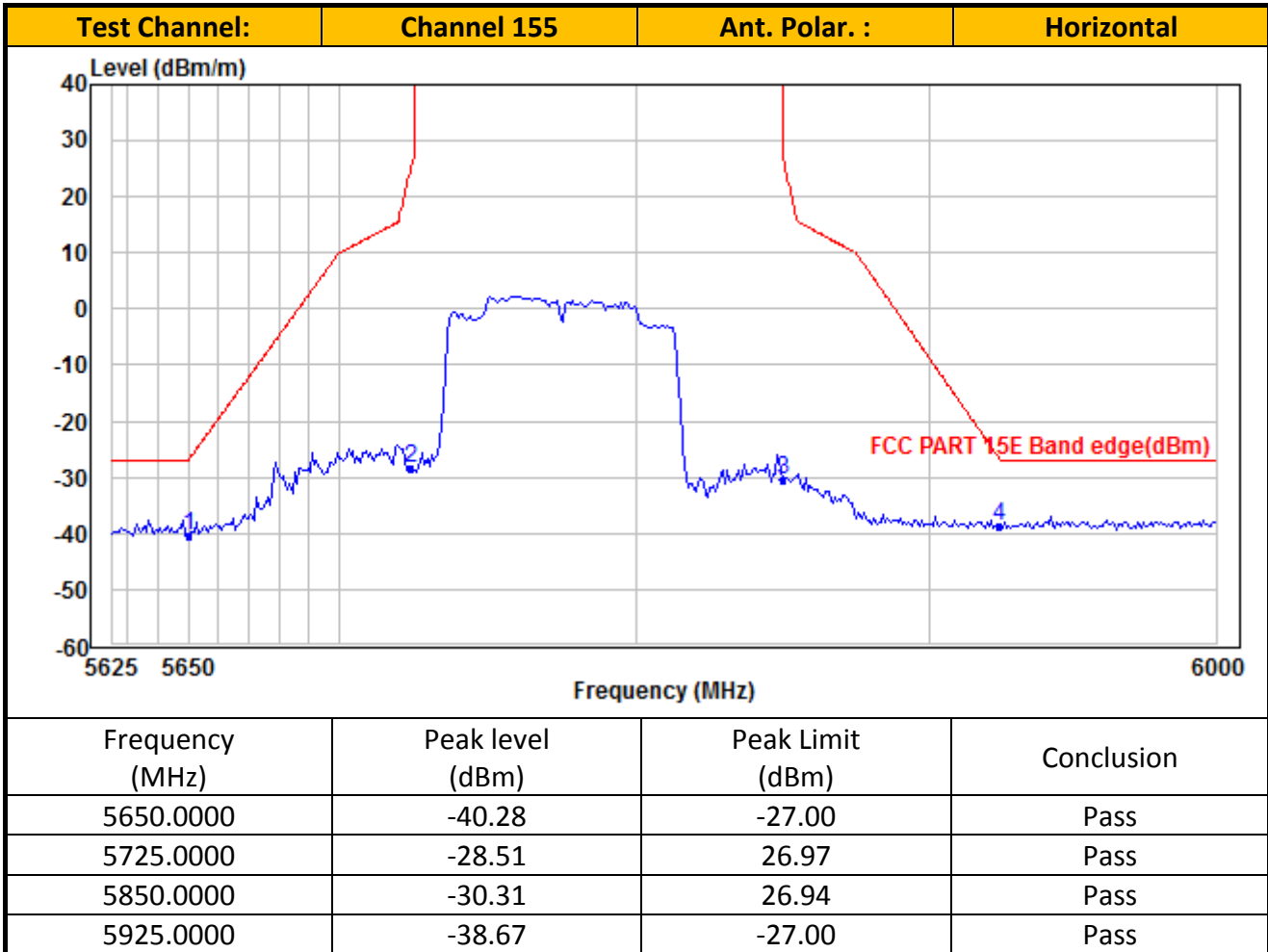

TEST REPORT

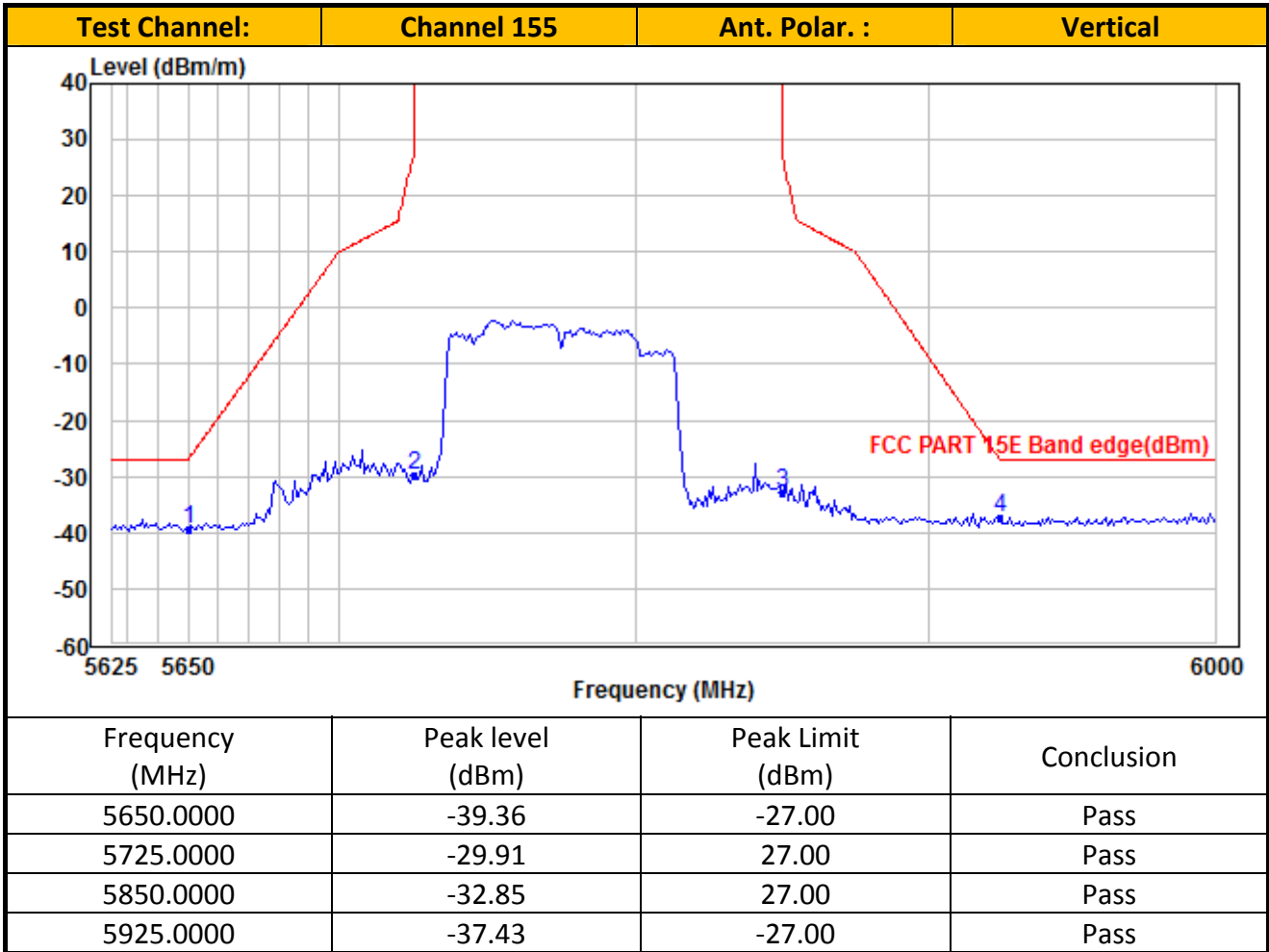

TEST REPORT

Ant. 2_ IEEE 802.11ac (80MHz) (MCS0)

IEEE 802.11ac-VHT80_Channel 42

No.	Frequency (MHz)	Reading (dBuV/m)	Correction factor (dB)	Result (dBuV/m)	Limit (dBuV/m)	Margin (dB)	Detector	Antenna Polaxis
1	10460.00	41.65	11.35	53.00	74.00	21.00	Peak	Horizontal
2	10460.00	29.50	11.35	40.85	54.00	13.15	Average	Horizontal
3	15690.00	38.40	11.03	49.43	74.00	24.57	Peak	Horizontal
4	15690.00	26.42	11.03	37.45	54.00	16.55	Average	Horizontal
5	10460.00	39.46	9.43	48.89	74.00	25.11	Peak	Vertical
6	10460.00	28.07	9.43	37.50	54.00	16.50	Average	Vertical
7	15690.00	38.91	11.98	50.89	74.00	23.11	Peak	Vertical
8	15690.00	27.00	11.98	38.98	54.00	15.02	Average	Vertical

IEEE 802.11ac-VHT80_Channel 58

No.	Frequency (MHz)	Reading (dBuV/m)	Correction factor (dB)	Result (dBuV/m)	Limit (dBuV/m)	Margin (dB)	Detector	Antenna Polaxis
1	10580.00	41.76	11.36	53.12	74.00	20.88	Peak	Horizontal
2	10580.00	28.90	11.36	40.26	54.00	13.74	Average	Horizontal
3	15870.00	39.50	11.29	50.79	74.00	23.21	Peak	Horizontal
4	15870.00	25.69	11.29	36.98	54.00	17.02	Average	Horizontal
5	10580.00	39.03	9.39	48.42	74.00	25.58	Peak	Vertical
6	10580.00	27.61	9.39	37.00	54.00	17.00	Average	Vertical
7	15870.00	39.70	12.38	52.08	74.00	21.92	Peak	Vertical
8	15870.00	26.73	12.38	39.11	54.00	14.89	Average	Vertical

IEEE 802.11ac-VHT80_Channel 106

No.	Frequency (MHz)	Reading (dBuV/m)	Correction factor (dB)	Result (dBuV/m)	Limit (dBuV/m)	Margin (dB)	Detector	Antenna Polaxis
1	11060.00	41.33	10.12	51.45	74.00	22.55	Peak	Horizontal
2	11060.00	28.93	10.12	39.05	54.00	14.95	Average	Horizontal
3	16590.00	36.30	13.31	49.61	74.00	24.39	Peak	Horizontal
4	16590.00	24.86	13.31	38.17	54.00	15.83	Average	Horizontal
5	11060.00	40.52	8.36	48.88	74.00	25.12	Peak	Vertical
6	11060.00	28.34	8.36	36.70	54.00	17.30	Average	Vertical
7	16590.00	37.58	13.29	50.87	74.00	23.13	Peak	Vertical
8	16590.00	25.24	13.29	38.53	54.00	15.47	Average	Vertical

TEST REPORT

IEEE 802.11ac-VHT80_Channel 122

No.	Frequency (MHz)	Reading (dBuV/m)	Correction factor (dB)	Result (dBuV/m)	Limit (dBuV/m)	Margin (dB)	Detector	Antenna Polaxis
1	11220.00	41.44	9.94	51.38	74.00	22.62	Peak	Horizontal
2	11220.00	28.80	9.94	38.74	54.00	15.26	Average	Horizontal
3	16830.00	39.79	13.21	53.00	74.00	21.00	Peak	Horizontal
4	16830.00	27.62	13.21	40.83	54.00	13.17	Average	Horizontal
5	11220.00	39.78	8.27	48.05	74.00	25.95	Peak	Vertical
6	11220.00	28.19	8.27	36.46	54.00	17.54	Average	Vertical
7	16830.00	41.33	12.85	54.18	74.00	19.82	Peak	Vertical
8	16830.00	27.85	12.85	40.70	54.00	13.30	Average	Vertical

IEEE 802.11ac-VHT80_Channel 155

No.	Frequency (MHz)	Reading (dBuV/m)	Correction factor (dB)	Result (dBuV/m)	Limit (dBuV/m)	Margin (dB)	Detector	Antenna Polaxis
1	11550.00	41.31	9.83	51.14	74.00	22.86	Peak	Horizontal
2	11550.00	29.36	9.83	39.19	54.00	14.81	Average	Horizontal
3	17325.00	38.76	14.36	53.12	74.00	20.88	Peak	Horizontal
4	17325.00	27.92	14.36	42.28	54.00	11.72	Average	Horizontal
5	11550.00	41.89	8.41	50.30	74.00	23.70	Peak	Vertical
6	11550.00	29.32	8.41	37.73	54.00	16.27	Average	Vertical
7	17325.00	39.54	13.57	53.11	74.00	20.89	Peak	Vertical
8	17325.00	26.63	13.57	40.20	54.00	13.80	Average	Vertical

TEST REPORT

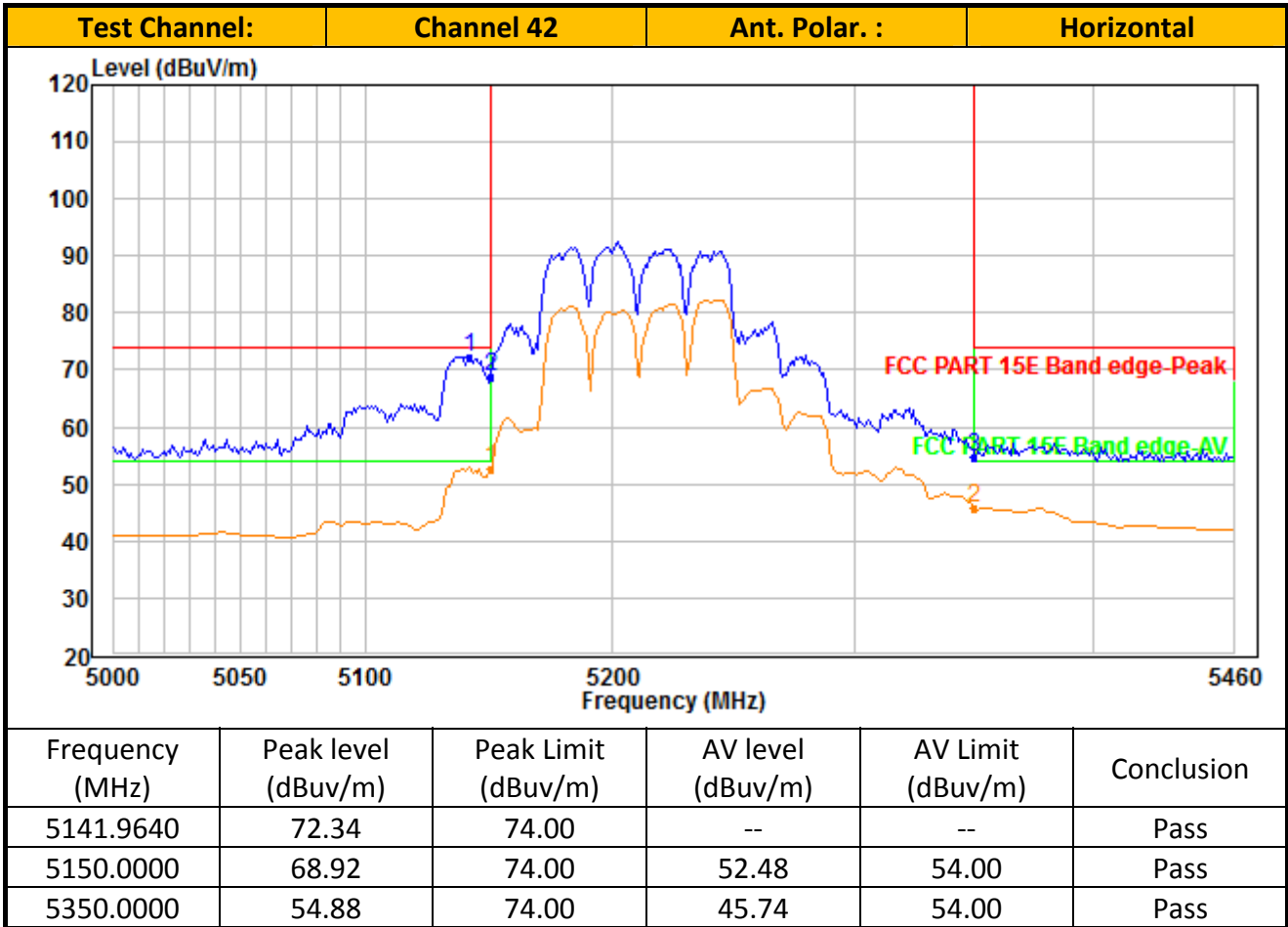

TEST REPORT

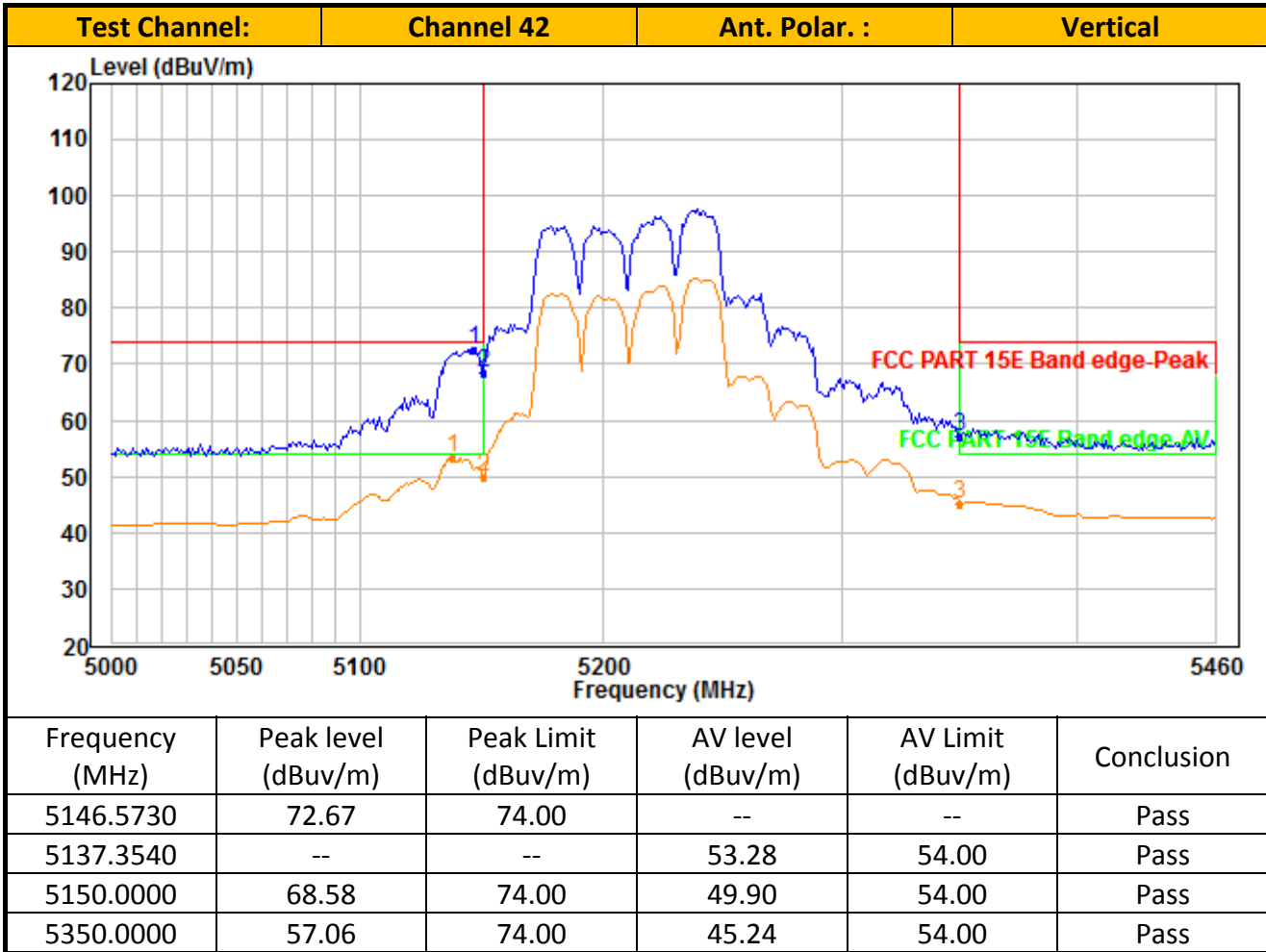

TEST REPORT

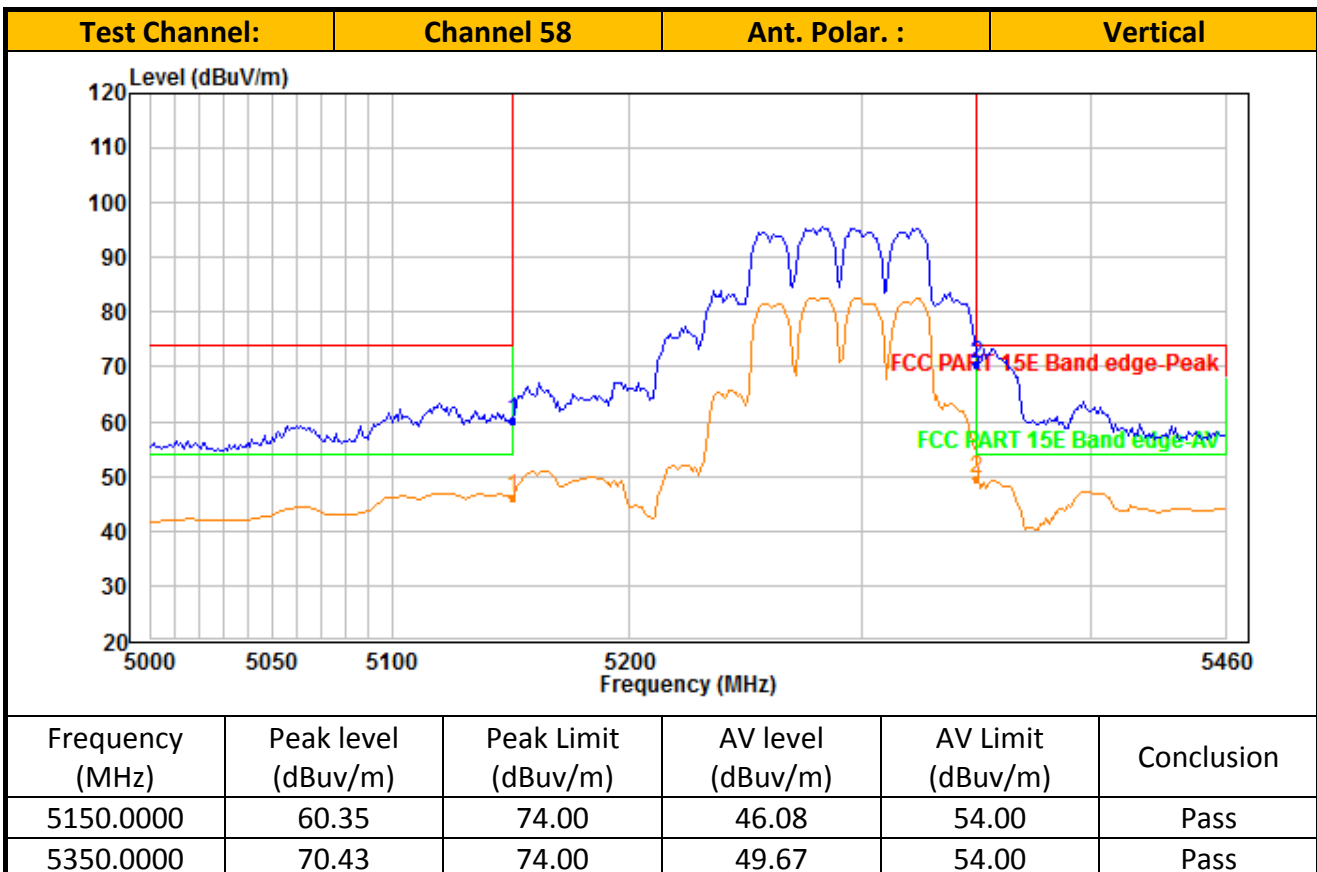
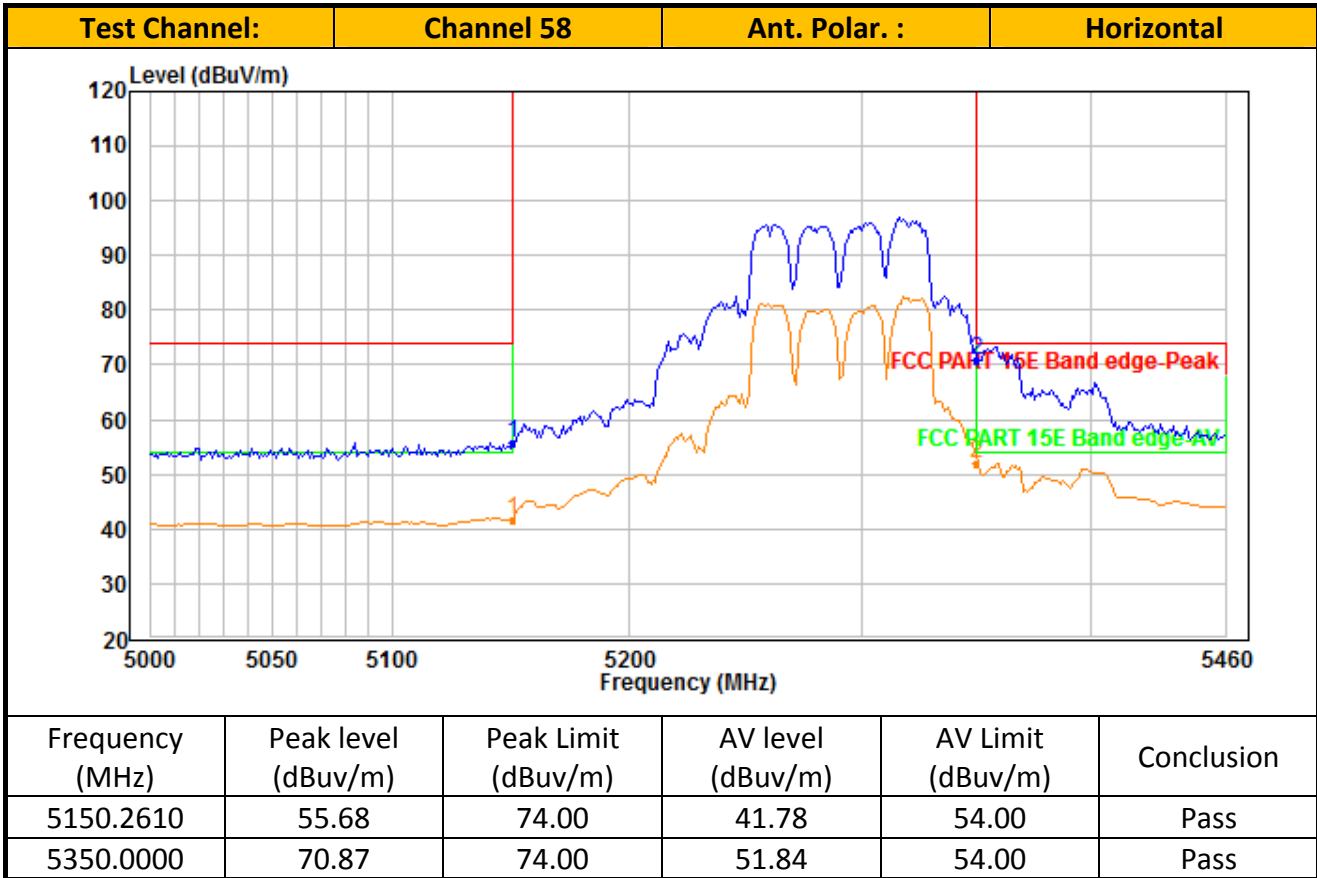

TEST REPORT

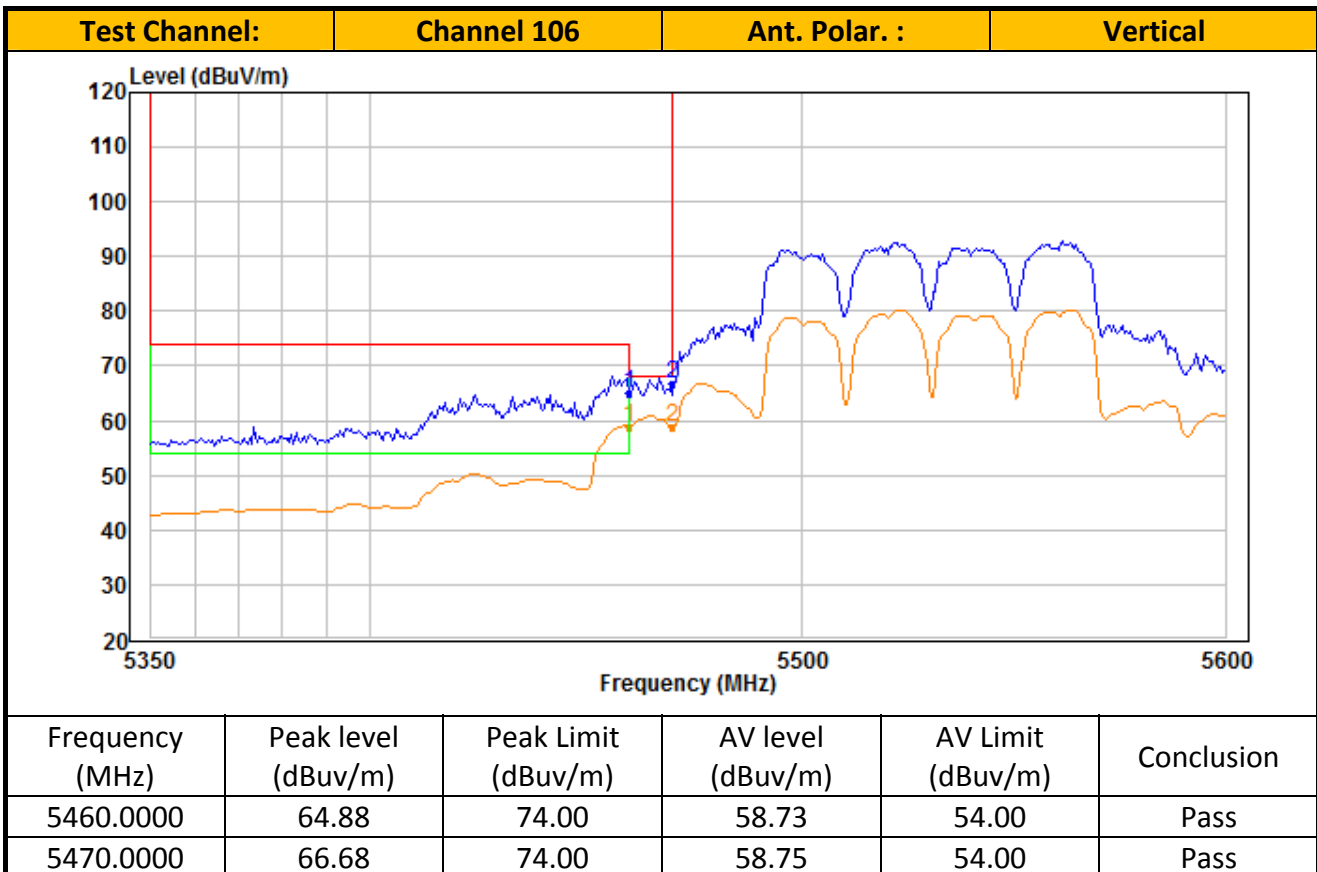
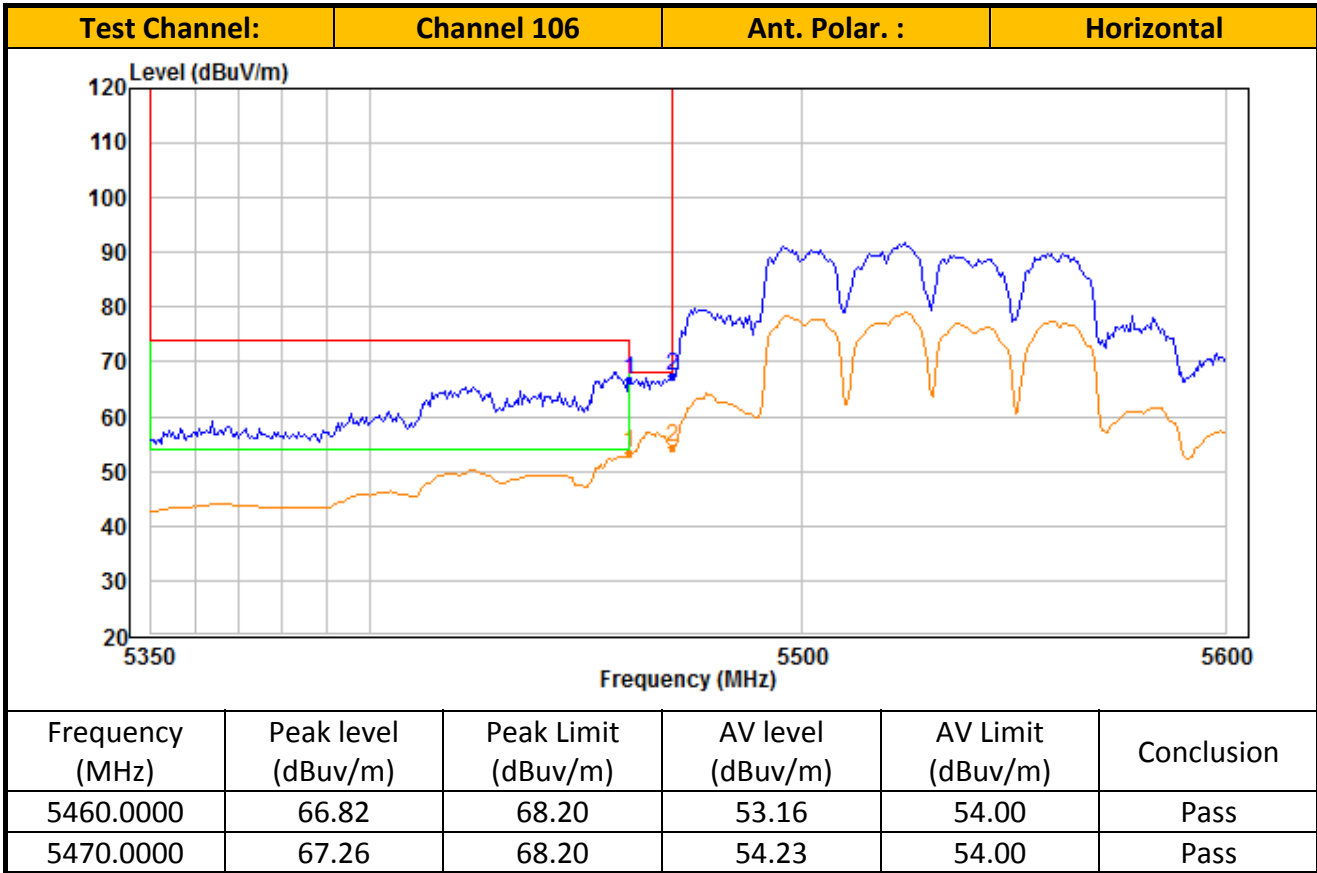

TEST REPORT

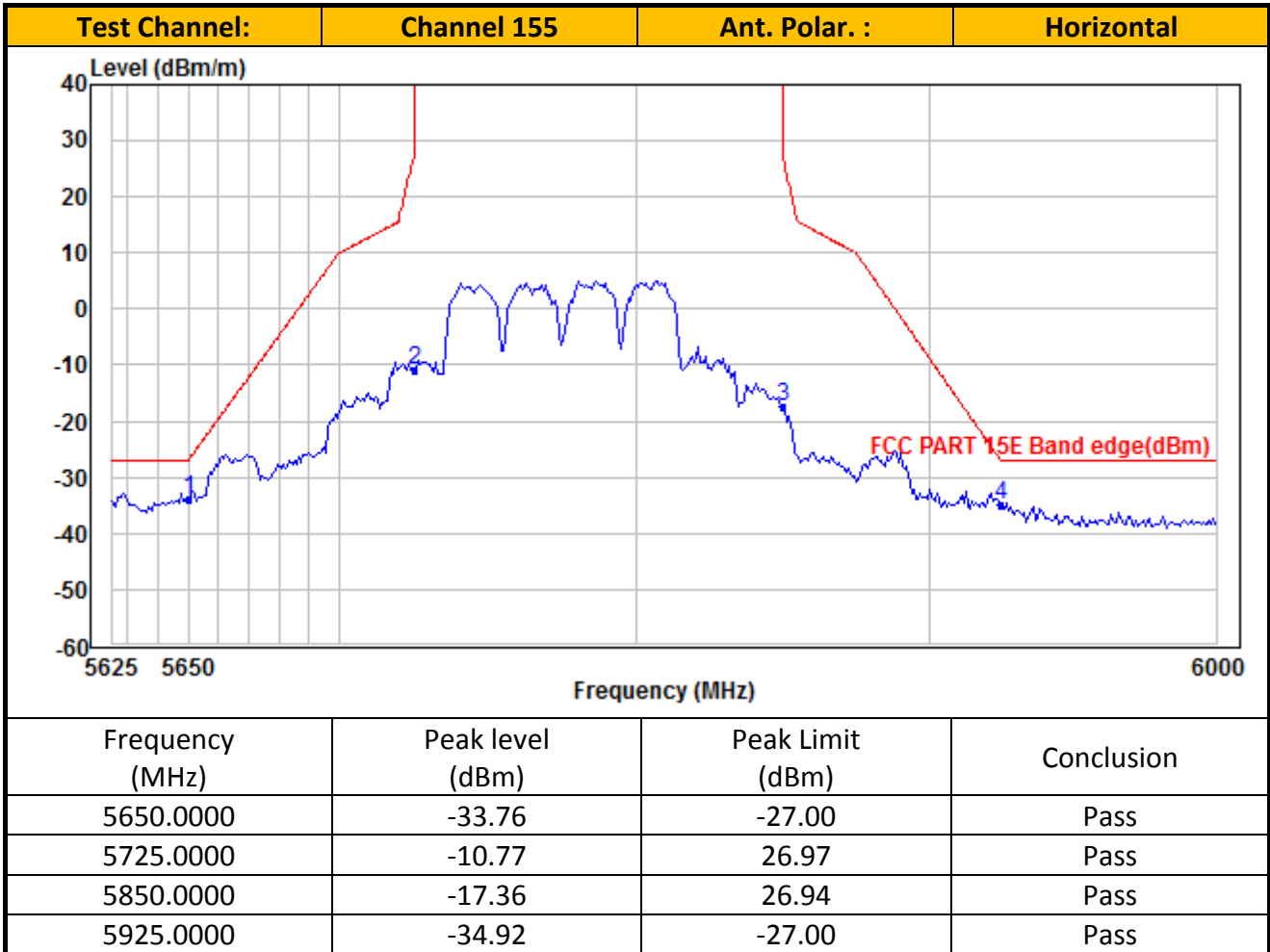

TEST REPORT

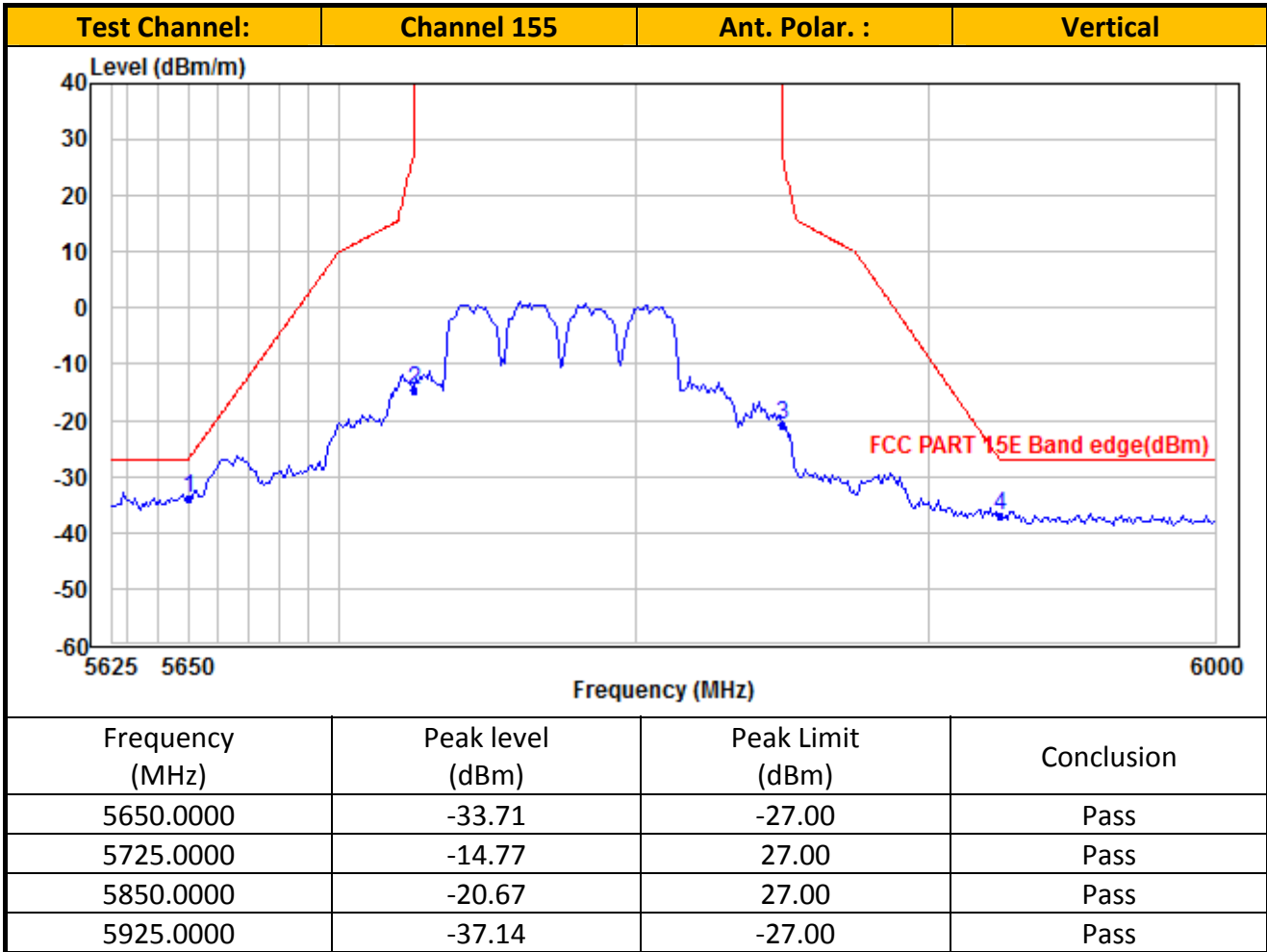

- NOTES:
1. Peak detector is used for the emission measurement.
 2. Average detector is used for the average data of emission measurement
 3. All measurements were made at 3 meters. Radiated emissions not detected at the 3-meter distance were measured at 0.3-meter and an inverse proportional extrapolation was performed to compare the signal level to the 3-meter limit. No other radiated emissions than those reported were detected at a test distance of 0.3-meter.
 4. Value in the margin column shows emission below limit.
 5. Horn antenna is used for the emission over 1000MHz.
 6. Emission (the row indicated by ***bold italic***) within the restricted band meets the requirement of FCC Part 15 Section 15.205 / RSS-Gen Section 8.10.
 7. For the measurement of radiated emission, summation method was used which numerical integrating (in terms of linear power) over the transmitter occupied bandwidth.
 8. For the linear power measurement, data in 1MHz spacing was collected by spectrum analyzer with 1MHz resolution bandwidth.

TEST REPORT

Mode: WIFI Connected

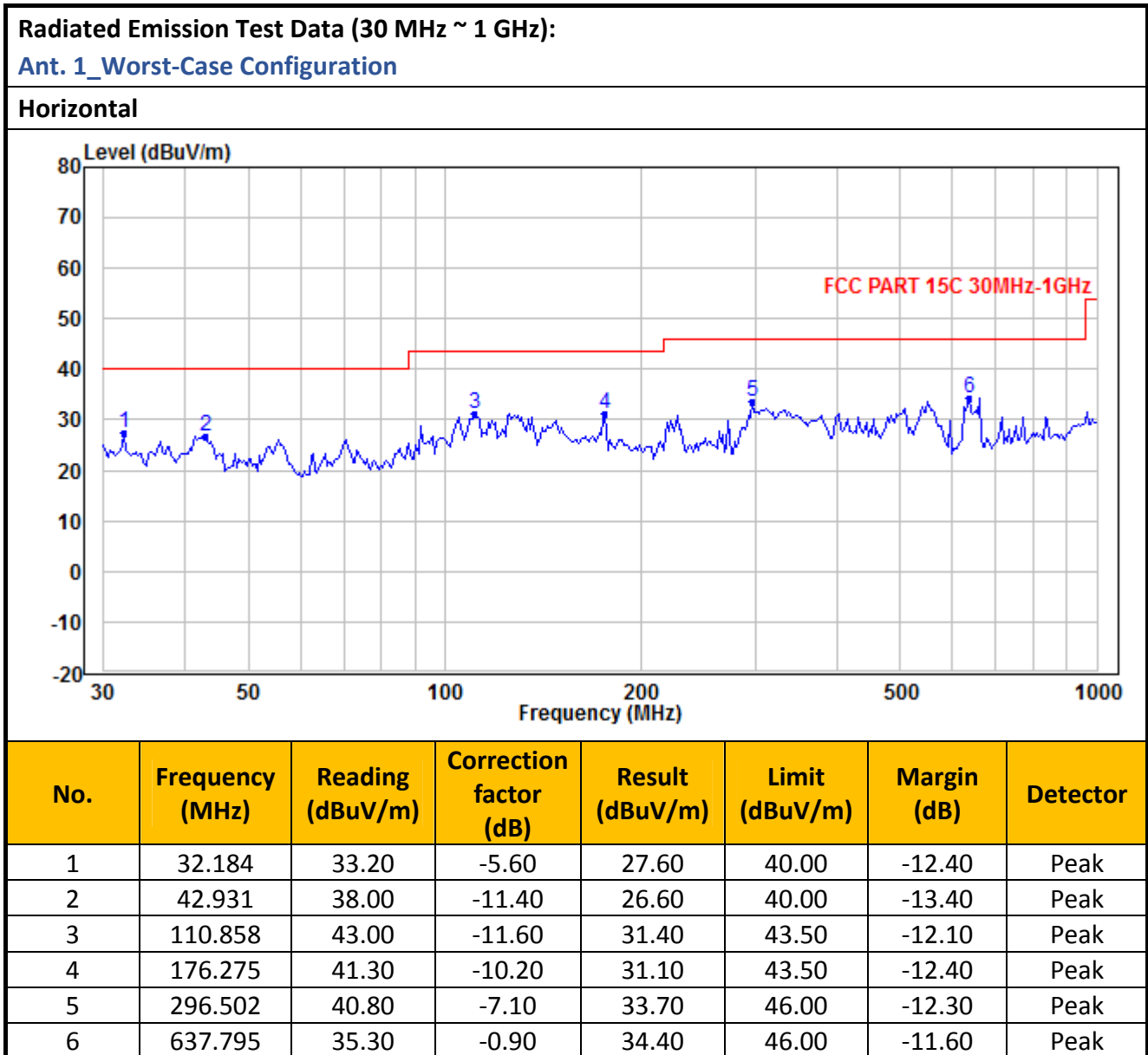

TEST REPORT

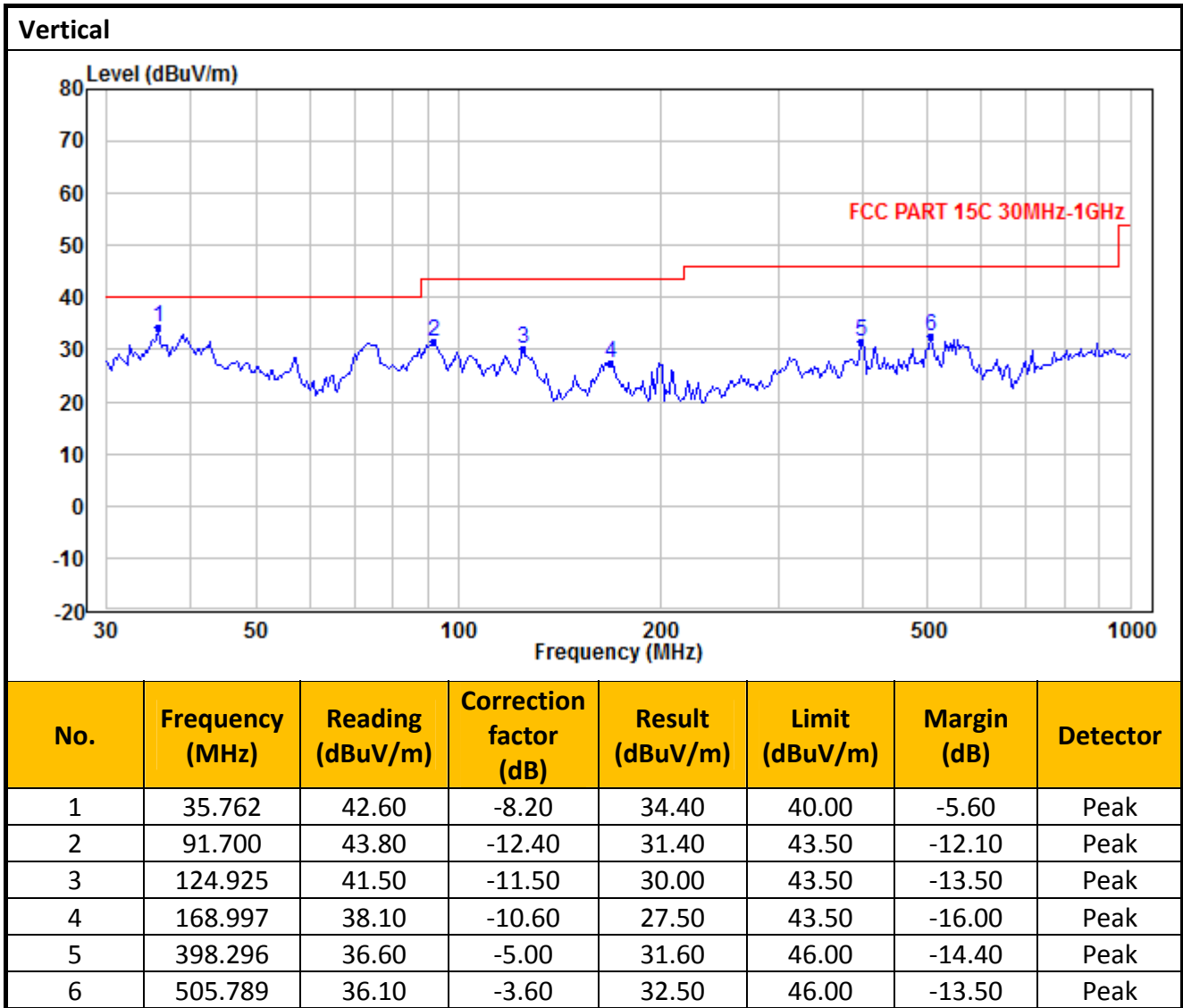

TEST REPORT

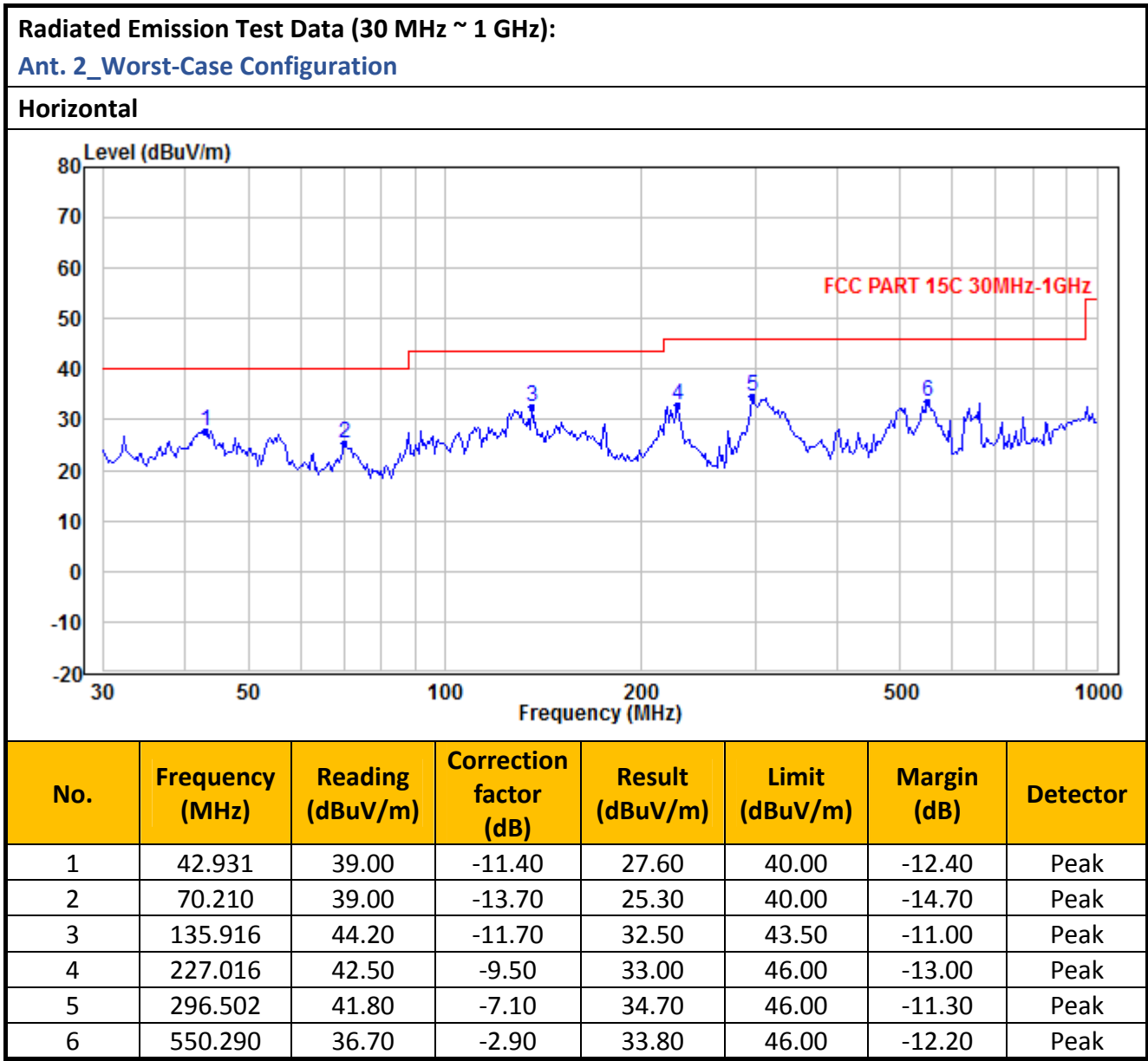

TEST REPORT

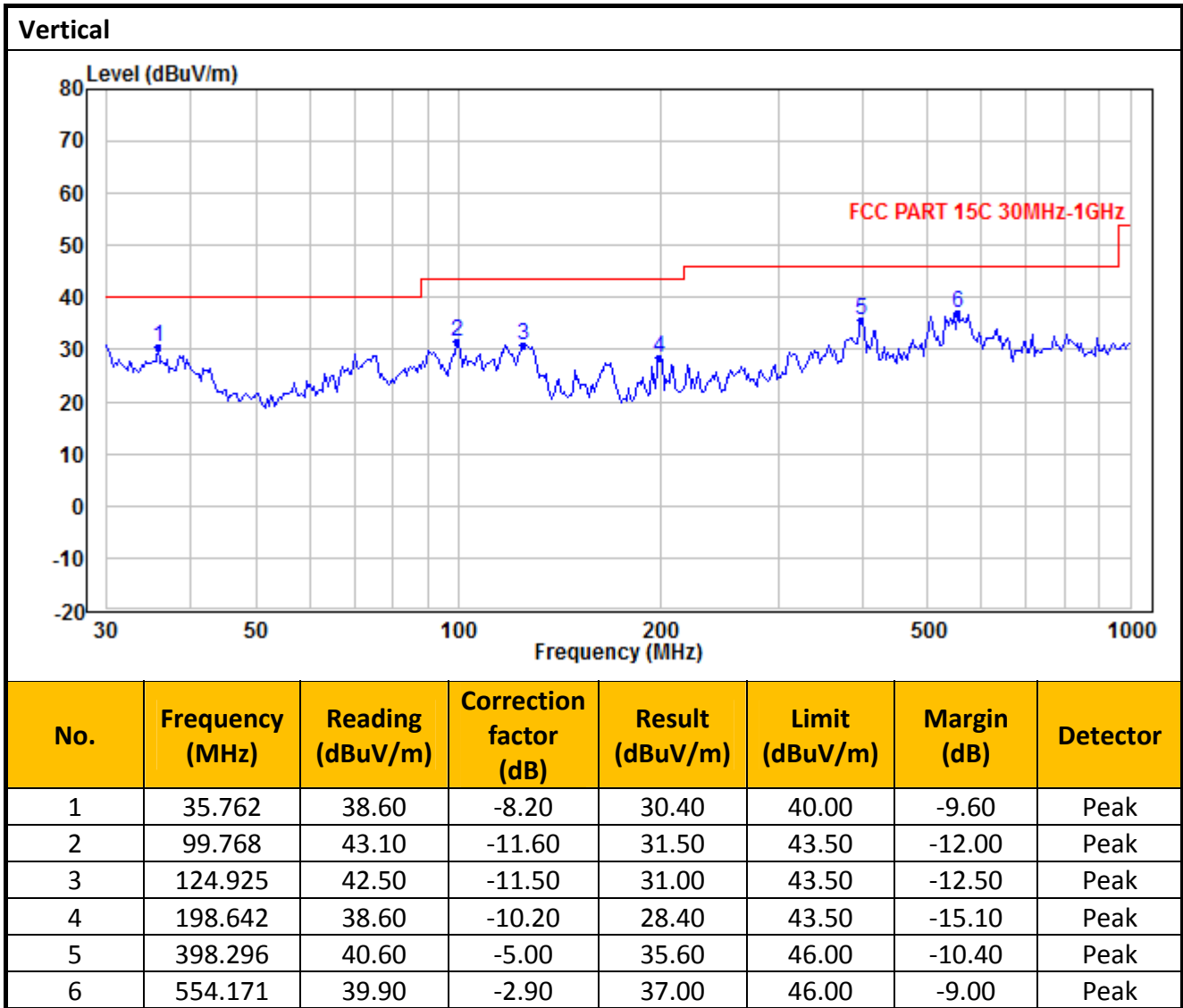

- NOTES:
1. Peak detector is used for the emission measurement.
 2. All measurements were made at 3 meters. Radiated emissions not detected at the 3-meter distance were measured at 0.3-meter and an inverse proportional extrapolation was performed to compare the signal level to the 3-meter limit. No other radiated emissions than those reported were detected at a test distance of 0.3-meter.
 3. Value in the margin column shows emission below limit.
 4. Emission (the row indicated by ***bold italic***) within the restricted band meets the requirement of FCC Part 15 Section 15.205.

TEST REPORT

4.6.3 Radiated Emission Test Setup

The figure below shows the test setup, which is utilized to make these measurements.

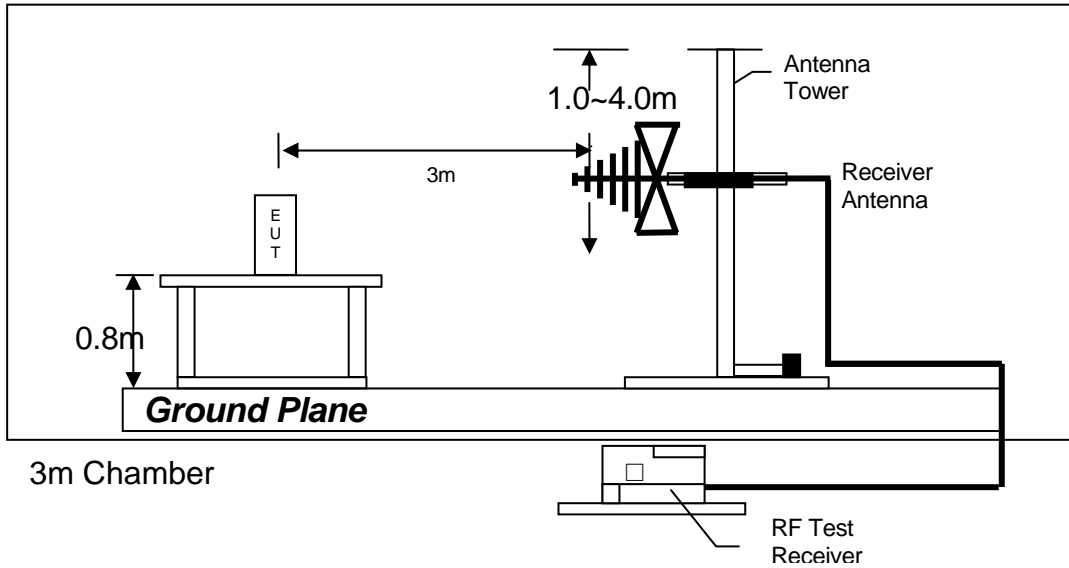

Test setup of radiated emissions up to 1GHz

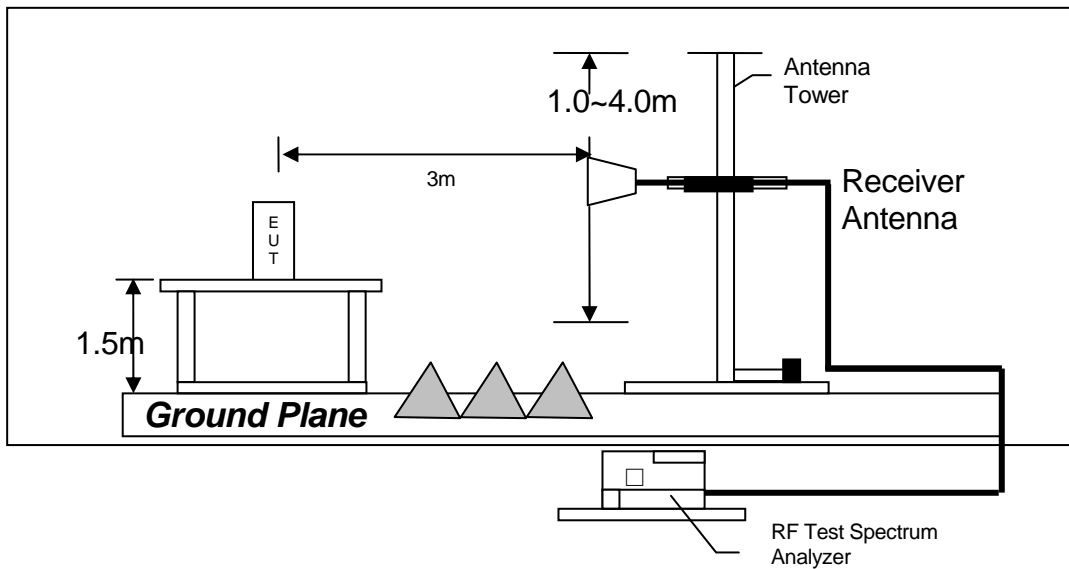

Test setup of radiated emissions above 1GHz

TEST REPORT

4.6.4 Transmitter Duty Cycle Calculation (Ant.1)

IEEE 802.11a

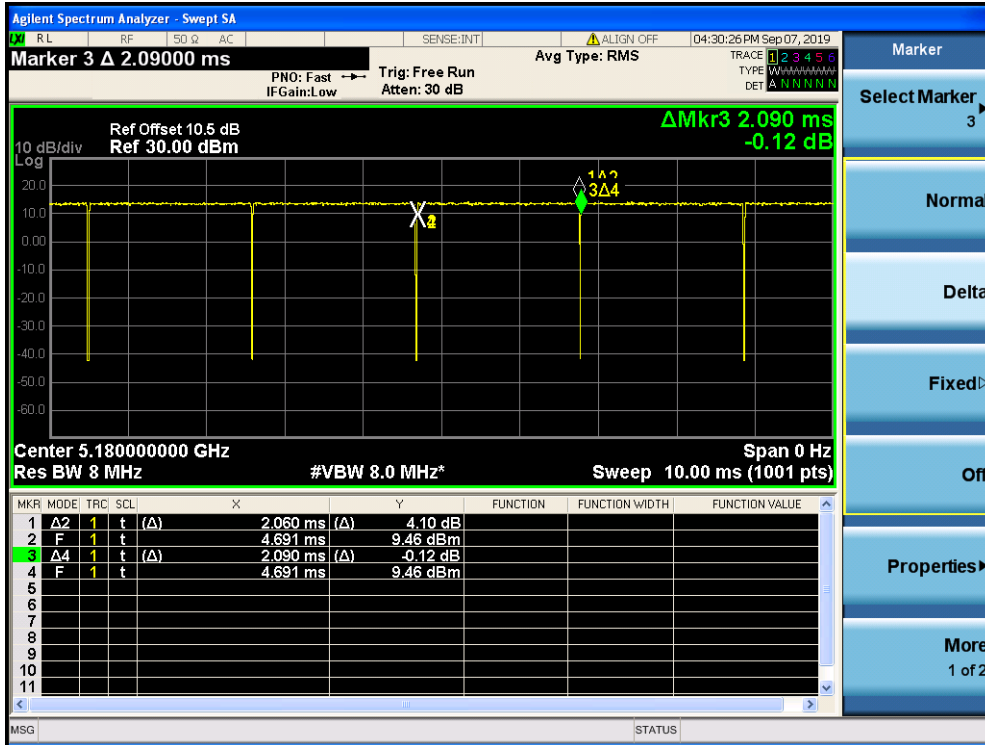

IEEE 802.11n20

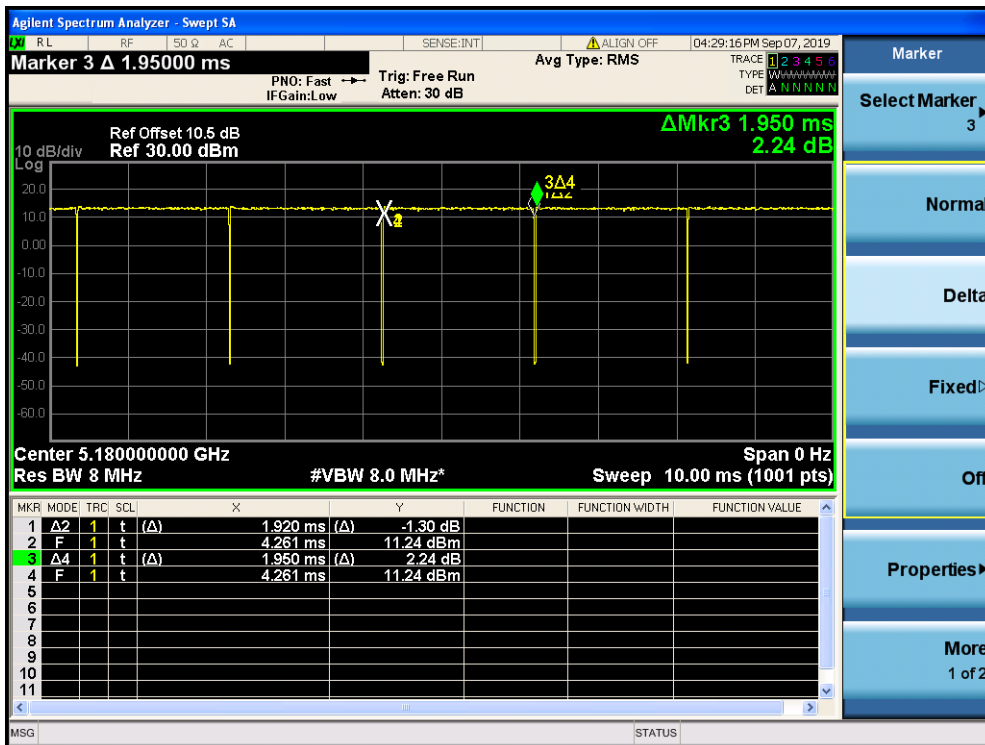

TEST REPORT

IEEE 802.11ac20

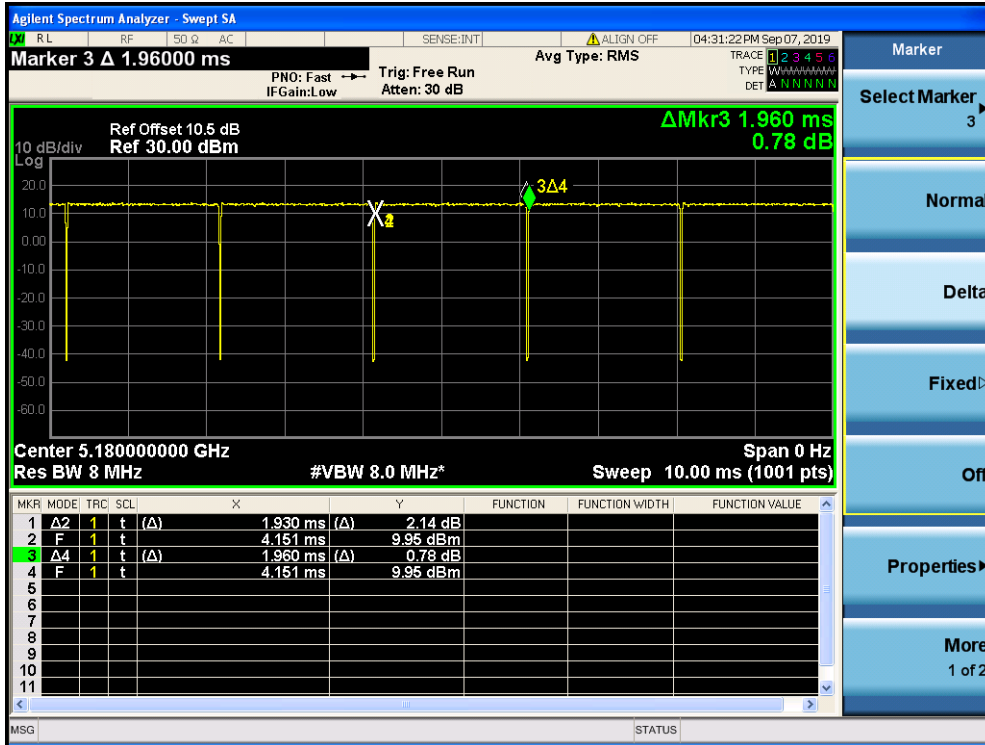

IEEE 802.11n40

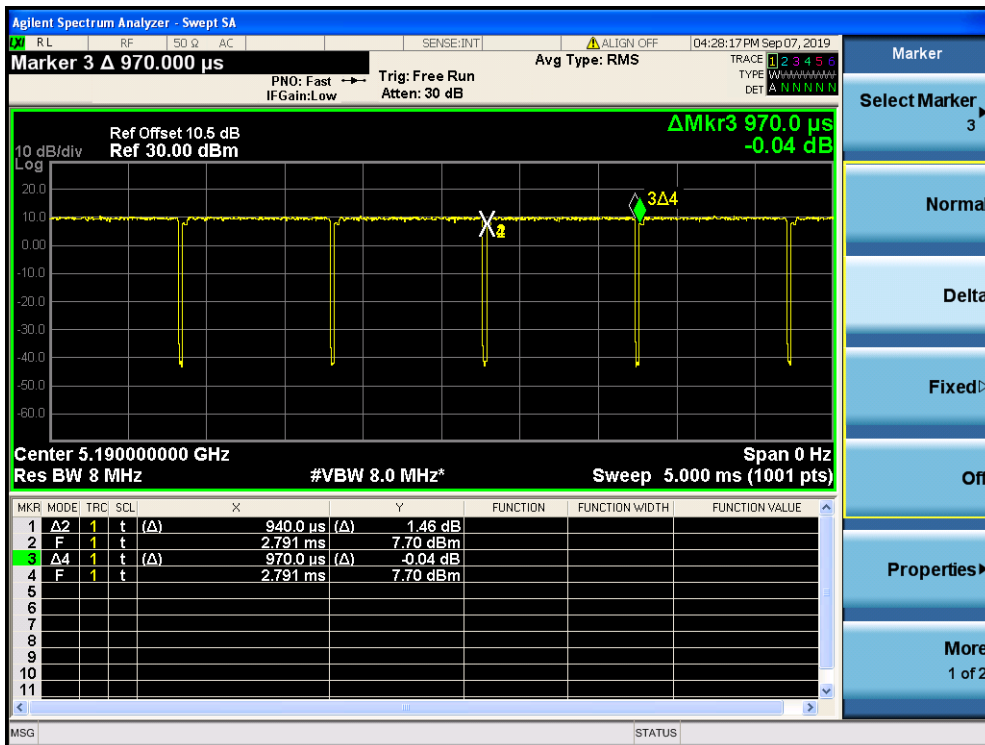

TEST REPORT

IEEE 802.11ac40

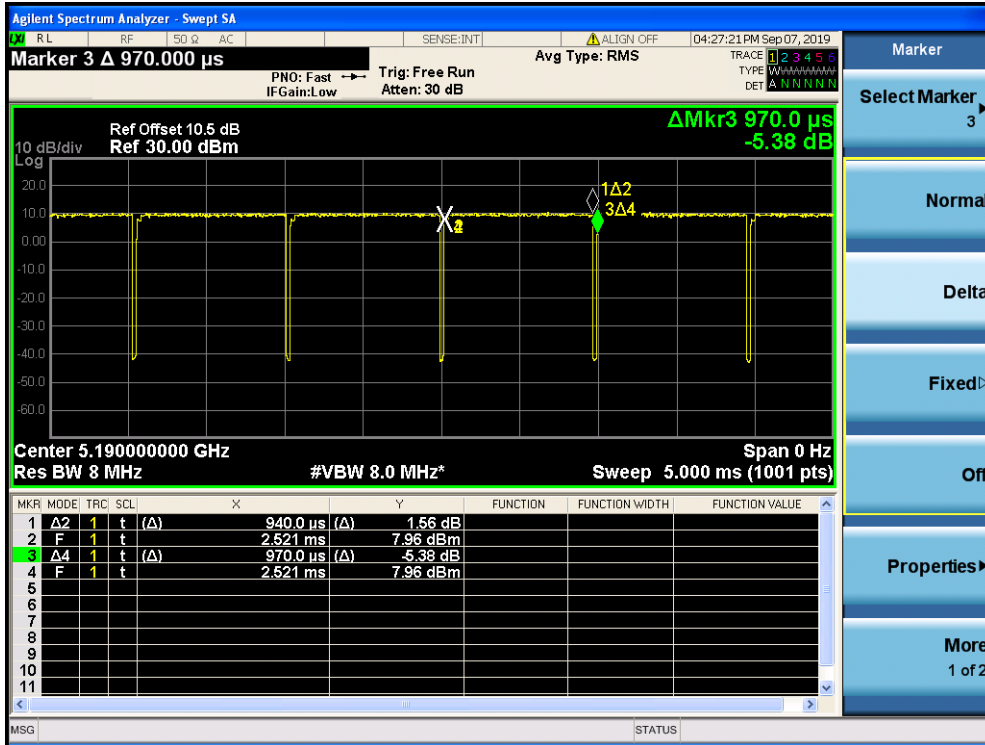

IEEE 802.11ac80

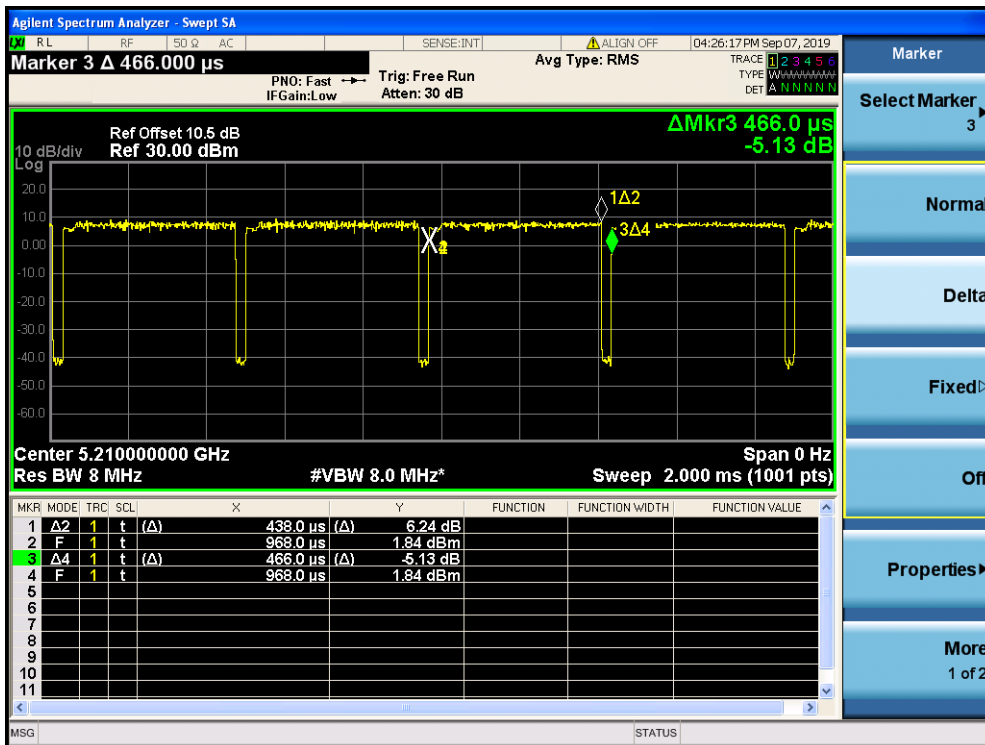

TEST REPORT

4.6.5 Transmitter Duty Cycle Calculation (Ant.2)

IEEE 802.11a

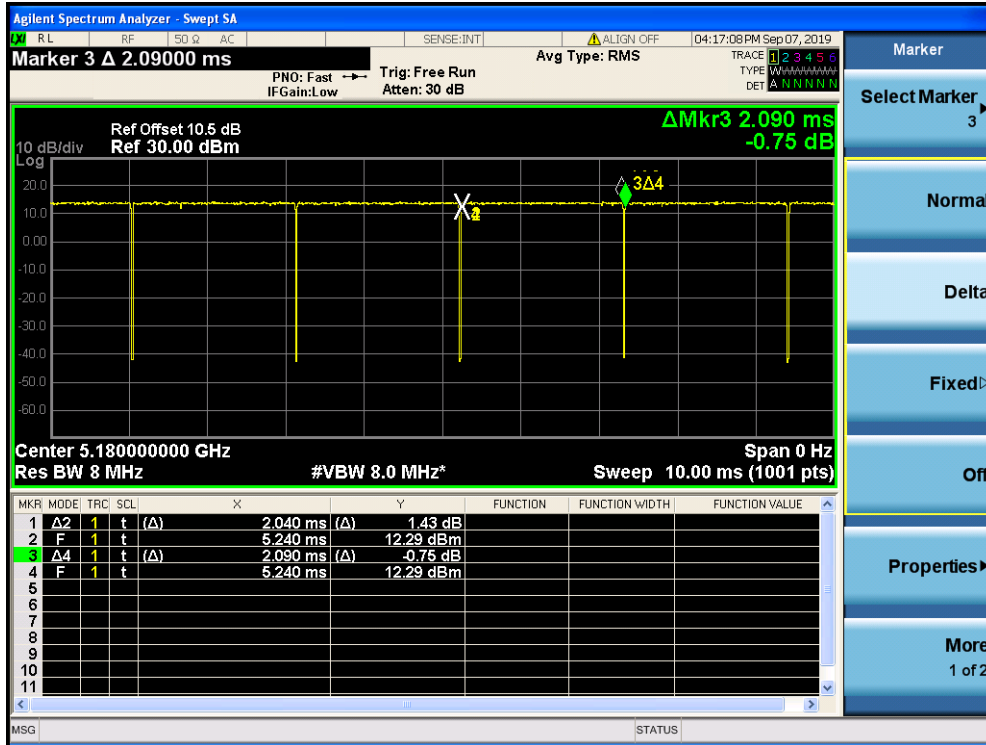

IEEE 802.11n20

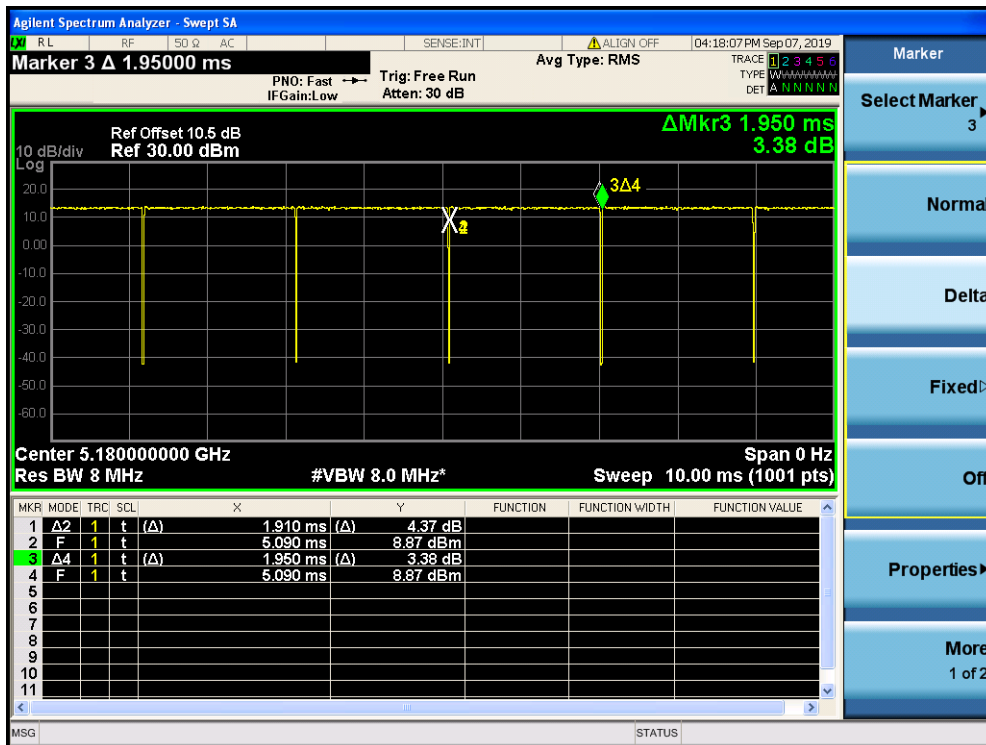

TEST REPORT

IEEE 802.11ac20

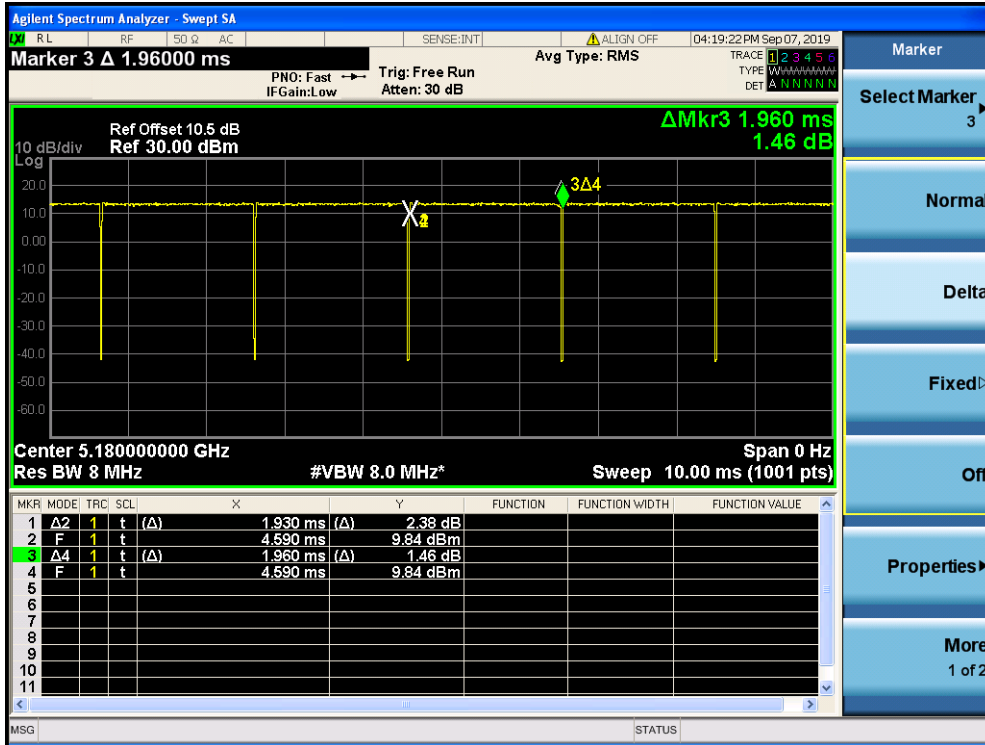

IEEE 802.11n40

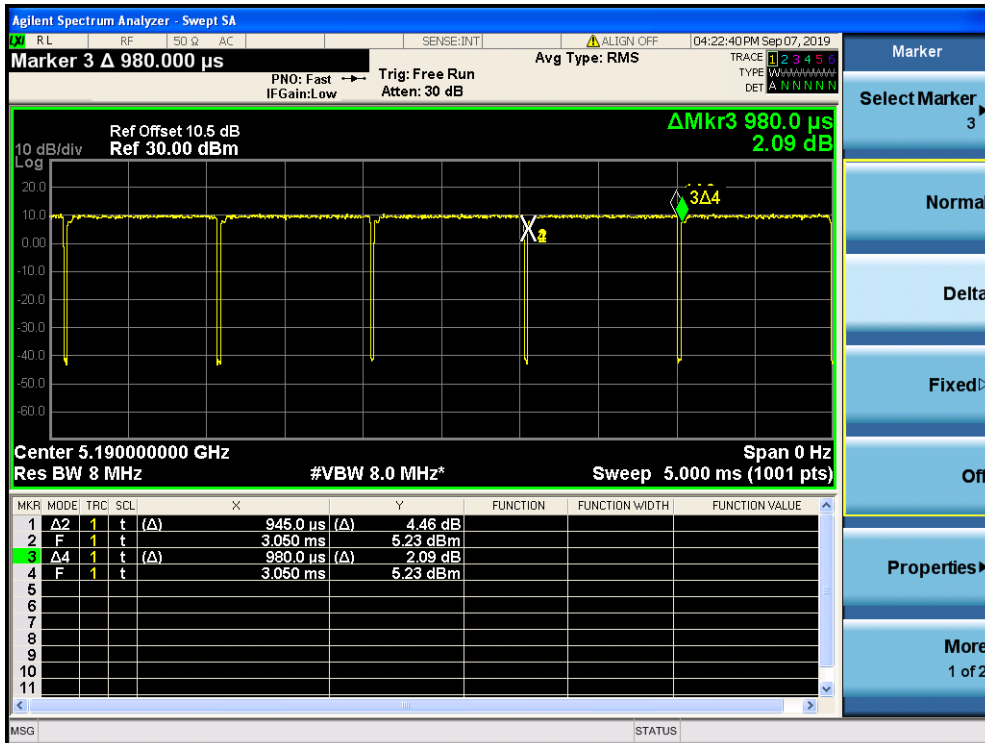

TEST REPORT

IEEE 802.11ac40

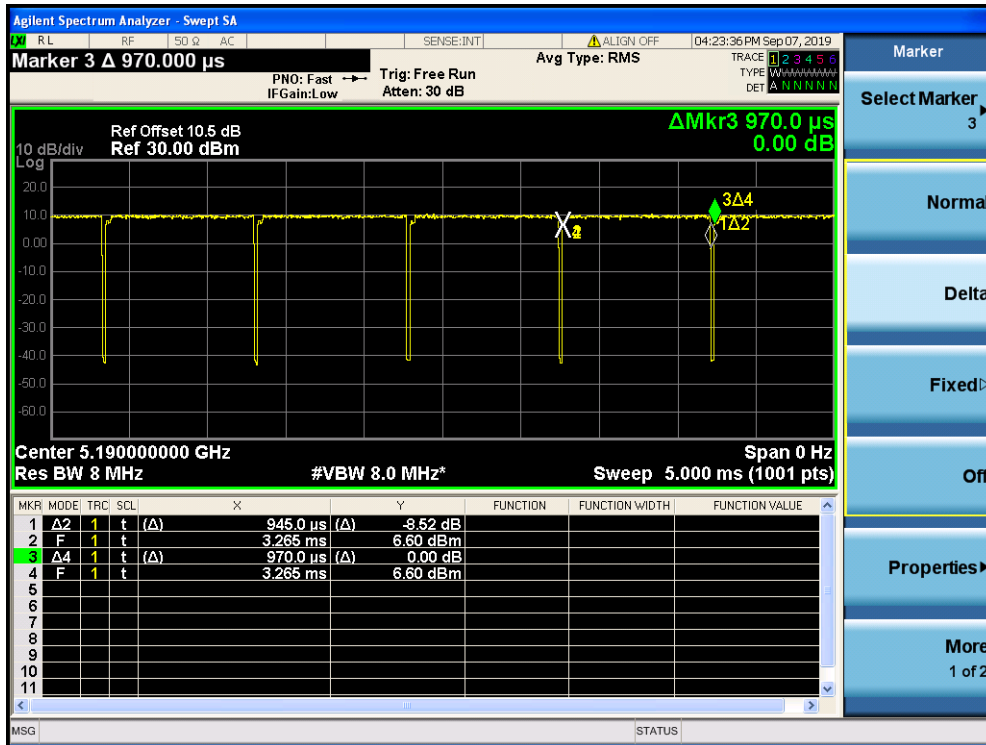

IEEE 802.11ac80

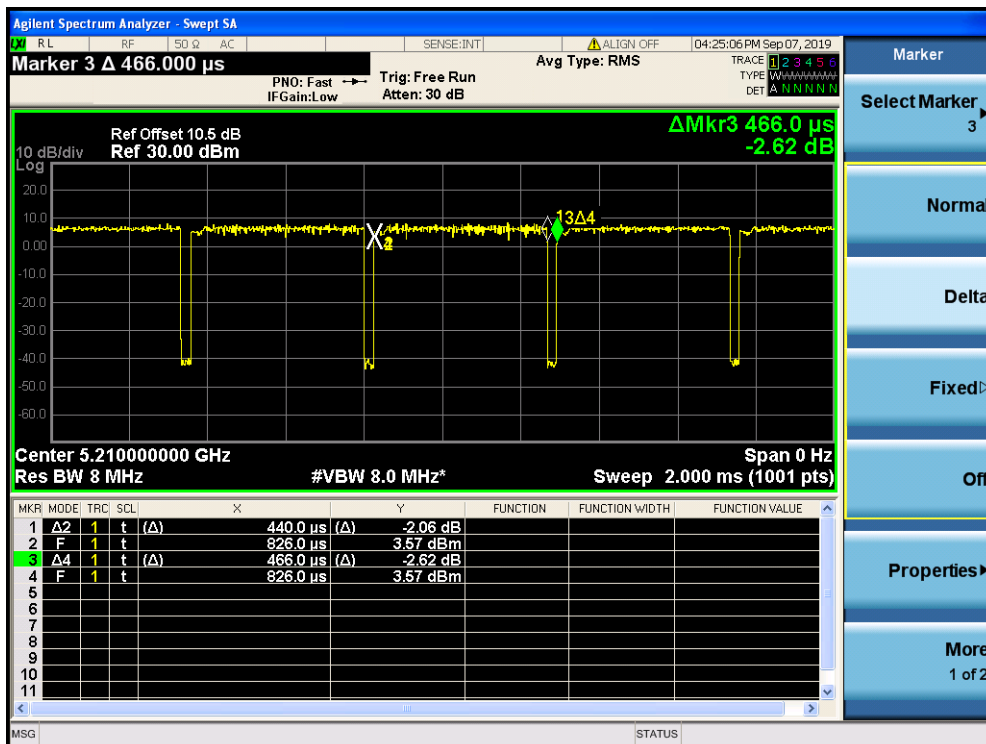

TEST REPORT

4.7 AC Power Line Conducted Emission

- Not applicable – EUT is only powered by battery for operation.
- EUT connects to AC power line. Emission Data is listed in following pages.

- Base Unit connects to AC power line and has transmission. Handset connects to AC power line but has no transmission. Emission Data of Base Unit is listed in following pages.

4.7.1 AC Power Line Conducted Emission Configuration Photograph

Worst Case Line-Conducted Configuration
at

15073.00 kHz

The worst case line conducted configuration photographs are attached in the Appendix and saved with filename: config photos.pdf

4.7.2 AC Power Line Conducted Emission Data

The plot(s) and data in the following pages list the significant emission frequencies, the limit and the margin of compliance.

Passed by 4.03 dB margin compare with Quasi-peak limit

TEST REPORT

AC POWER LINE CONDUCTED EMISSION

Worst Case: WiFi Operating

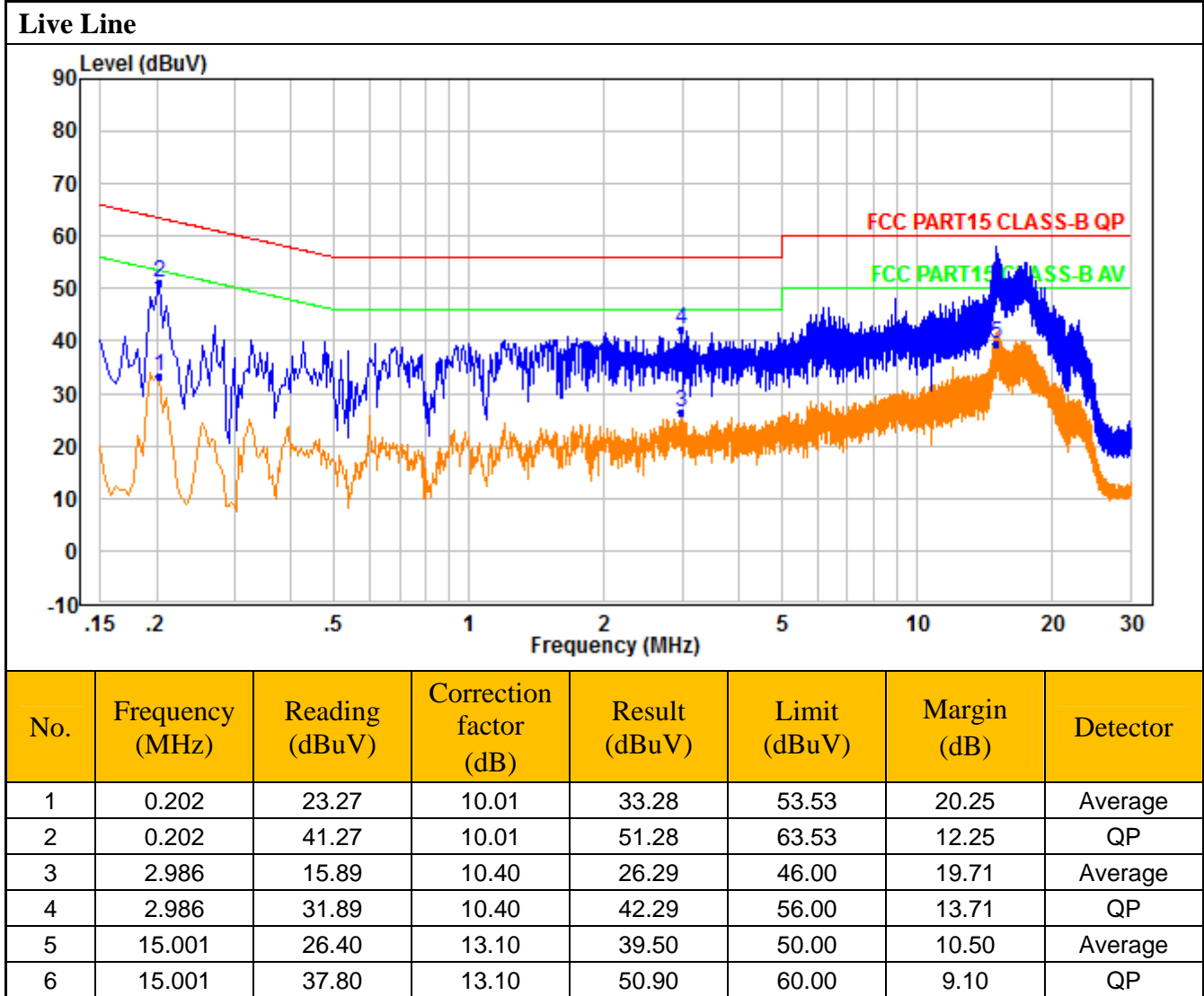

TEST REPORT

Worst Case: WiFi Operating

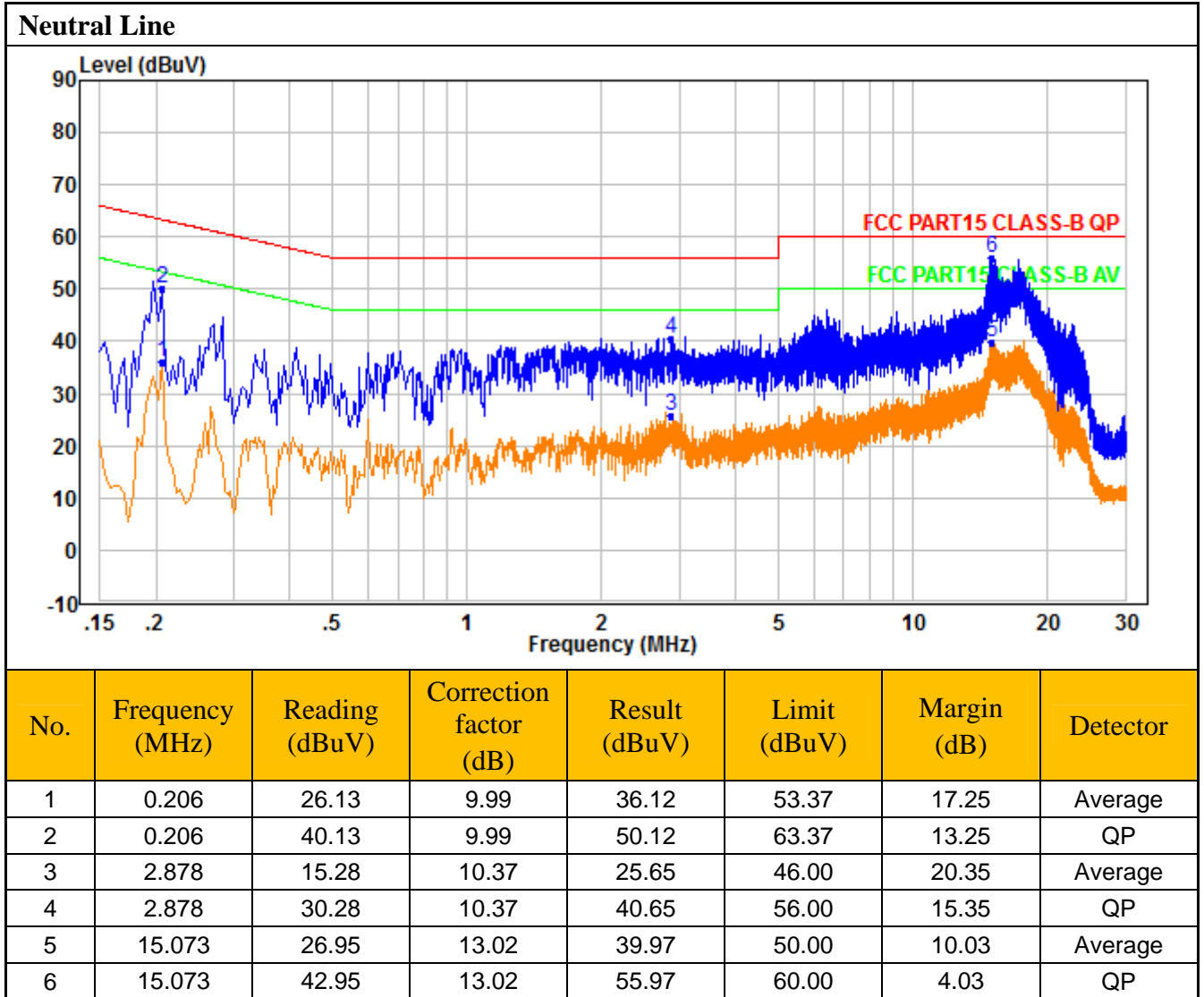

TEST REPORT

4.7.3 Conducted Emission Test Setup

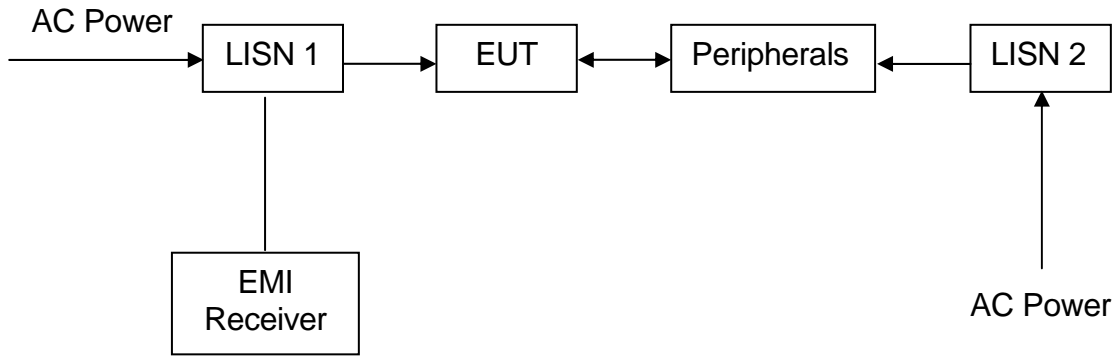

TEST REPORT

4.8 DFS Channel Shutdown and Non-occupancy period

According to standard 905462 DO2 UNII DFS Compliance procedures New Rules v02 section 5.1.1 and 5.1.2.

Master Devices

- a) The Master Device will use DFS in order to detect Radar Waveforms with received signal strength above the DFS Detection Threshold in the 5250 - 5350 MHz and 5470- 5725 MHz bands. DFS is not required in the 5150 - 5250 MHz or 5725 - 5825 MHz bands.
- b) Before initiating a network on a Channel, the Master Device will perform a Channel Availability Check for a specified time duration (Channel Availability Check Time) to ensure that there is no radar system operating on the Channel, using DFS described under subsection a) above.
- c) The Master Device initiates a U-NII network by transmitting control signals that will enable other U-NII devices to Associate with the Master Device.
- d) During normal operation, the Master Device will monitor the Channel (In-Service Monitoring) to ensure that there is no radar system operating on the Channel, using DFS described under a).
- e) If the Master Device has detected a Radar Waveform during In-Service Monitoring as described under d), the Operating Channel of the U-NII network is no longer an Available Channel. The Master Device will instruct all associated Client Device(s) to stop transmitting on this Channel within the Channel Move Time. The transmissions during the Channel Move Time will be limited to the Channel Closing Transmission Time.
- f) Once the Master Device has detected a Radar Waveform it will not utilize the Channel for the duration of the Non-Occupancy Period. 3
- g) If the Master Device delegates the In-Service Monitoring to a Client Device, then the combination will be tested to the requirements described under d) through f) above.

TEST REPORT

Client Devices

- a) A Client Device will not transmit before having received appropriate control signals from a Master Device.
- b) A Client Device will stop all its transmissions whenever instructed by a Master Device to which it is associated and will meet the Channel Move Time and Channel Closing Transmission Time requirements. The Client Device will not resume any transmissions until it has again received control signals from a Master Device.
- c) If a Client Device is performing In-Service Monitoring and detects a Radar Waveform above the DFS Detection Threshold, it will inform the Master Device. This is equivalent to the Master Device detecting the Radar Waveform and d) through f) of section 5.1.1 apply.
- d) Irrespective of Client Device or Master Device detection the Channel Move Time and Channel Closing Transmission Time requirements remain the same.
- e) The client test frequency must be monitored to ensure no transmission of any type has occurred for 30 minutes. Note: If the client moves with the master, the device is considered compliant if nothing appears in the client non-Occupancy period test. For devices that shut down (rather than moving channels), no beacons should appear.

TEST REPORT

4.10.1 Applicability of DFS requirement during normal operation

Requirement	Operational Mode	
	Master Device or Client with Radar Detection	Client Without Radar Detection
<i>DFS Detection Threshold</i>	Yes	Not required
<i>Channel Closing Transmission Time</i>	Yes	Yes
<i>Channel Move Time</i>	Yes	Yes
<i>U-NII Detection Bandwidth</i>	Yes	Not required

Additional requirements for devices with multiple bandwidth modes	Master Device or Client with Radar Detection	Client Without Radar Detection
<i>U-NII Detection Bandwidth and Statistical Performance Check</i>	All BW modes must be tested	Not required
<i>Channel Move Time and Channel Closing Transmission Time</i>	Test using widest BW mode available	Test using the widest BW mode available for the link
<i>All other tests</i>	Any single BW mode	Not required
<p>Note: Frequencies selected for statistical performance check (Section 7.8.4) should include several frequencies within the radar detection bandwidth and frequencies near the edge of the radar detection bandwidth. For 802.11 devices it is suggested to select frequencies in each of the bonded 20 MHz channels and the channel center frequency.</p>		

The operational behavior and individual DFS requirements that are associated with these modes are as follows:

TEST REPORT

4.10.2 Response Requirements

Parameter	Value
<i>Non-occupancy period</i>	Minimum 30 minutes
<i>Channel Availability Check Time</i>	60 seconds
<i>Channel Move Time</i>	10 seconds See Note 1.
<i>Channel Closing Transmission Time</i>	200 milliseconds + an aggregate of 60 milliseconds over remaining 10 second period. See Notes 1 and 2.
<i>U-NII Detection Bandwidth</i>	Minimum 100% of the U-NII 99% transmission power bandwidth. See Note 3.
<p>Note 1: <i>Channel Move Time</i> and the <i>Channel Closing Transmission Time</i> should be performed with Radar Type 0. The measurement timing begins at the end of the Radar Type 0 burst.</p> <p>Note 2: The <i>Channel Closing Transmission Time</i> is comprised of 200 milliseconds starting at the beginning of the <i>Channel Move Time</i> plus any additional intermittent control signals required to facilitate a <i>Channel</i> move (an aggregate of 60 milliseconds) during the remainder of the 10 second period. The aggregate duration of control signals will not count quiet periods in between transmissions.</p> <p>Note 3: During the <i>U-NII Detection Bandwidth</i> detection test, radar type 0 should be used. For each frequency step the minimum percentage of detection is 90 percent. Measurements are performed with no data traffic.</p>	

TEST REPORT

4.10.3 Short pulse Radar test Wave forms

Radar Type	Pulse Width (μsec)	PRI (μsec)	Number of Pulses	Minimum Percentage of Successful Detection	Minimum Number of Trials
0	1	1428	18	See Note 1	See Note 1
1	1	Test A: 15 unique PRI values randomly selected from the list of 23 PRI values in Table 5a	Roundup $\left\{ \begin{matrix} \left(\frac{1}{360} \right) \\ \left(\frac{19 \cdot 10^6}{PRI_{\mu sec}} \right) \end{matrix} \right\}$	60%	30
		Test B: 15 unique PRI values randomly selected within the range of 518-3066 μsec, with a minimum increment of 1 μsec, excluding PRI values selected in Test A			
2	1-5	150-230	23-29	60%	30
3	6-10	200-500	16-18	60%	30
4	11-20	200-500	12-16	60%	30
Aggregate (Radar Types 1-4)				80%	120
Note 1: Short Pulse Radar Type 0 should be used for the detection bandwidth test, channel move time, and channel closing time tests.					

TEST REPORT

4.10.5 Calibration Setup and DFS Test Results

4.10.5.1 Calibration of Radar Waveform

4.10.5.2 Calibration Procedure:

The Interference Radar Detection Threshold Level is -64dBm that had been taken into account the output power range and antenna gain. The following equipment setup was used to calibrate the conducted Radar Waveform. A vector signal generator was utilized to establish the test signal level for radar type 0. During this process there were no transmissions by either the Master or client device. The Spectrum analyzer was switched was used. The spectrum analyzer resolution bandwidth (RBW) and video bandwidth (VBW) were set to 1MHz or 3MHz respectively to measure the type 0 radar waveform. The spectrum analyzer had offset to compensate and RF cable loss. The vector signal generator amplitude was set so that the power level measured at the spectrum analyzer was -64dBm. Capture the spectrum analyzer plots on short pulse radar waveform.

4.10.5.3 Conducted Setup

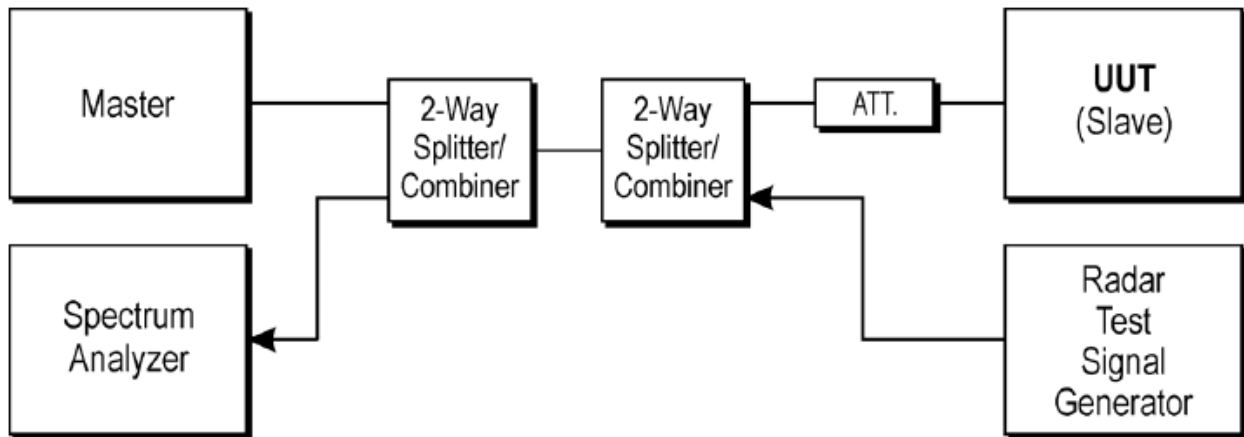

TEST REPORT

4.10.7 Radar Waveform Calibration Result

5290.000000MHz

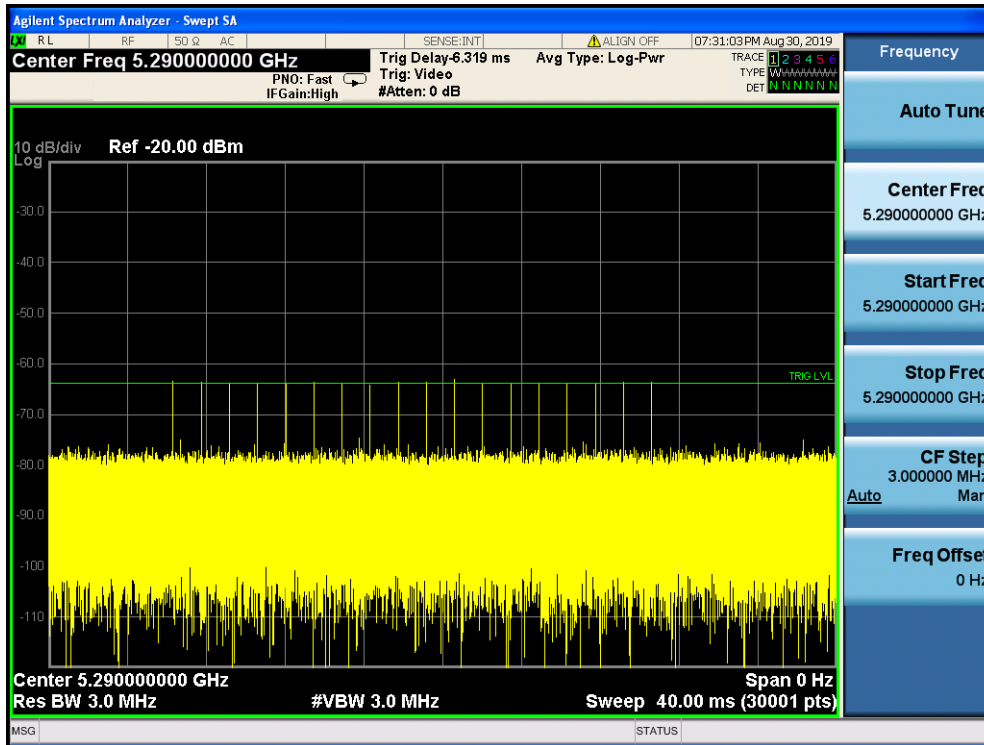

5300.000000MHz

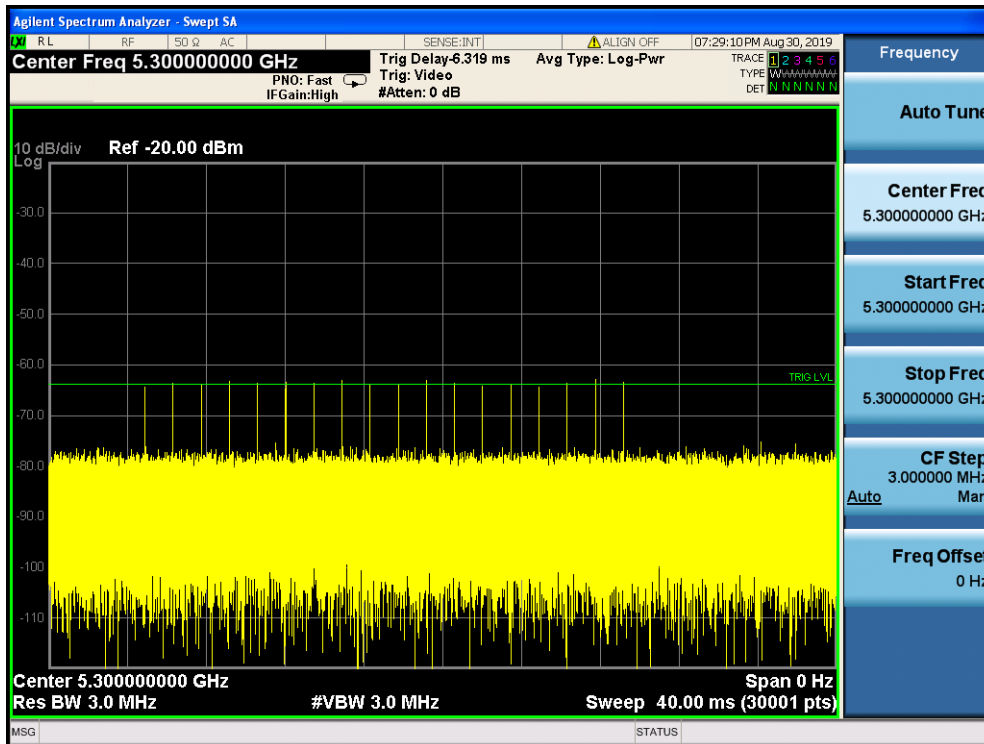

TEST REPORT

5500.000000MHz

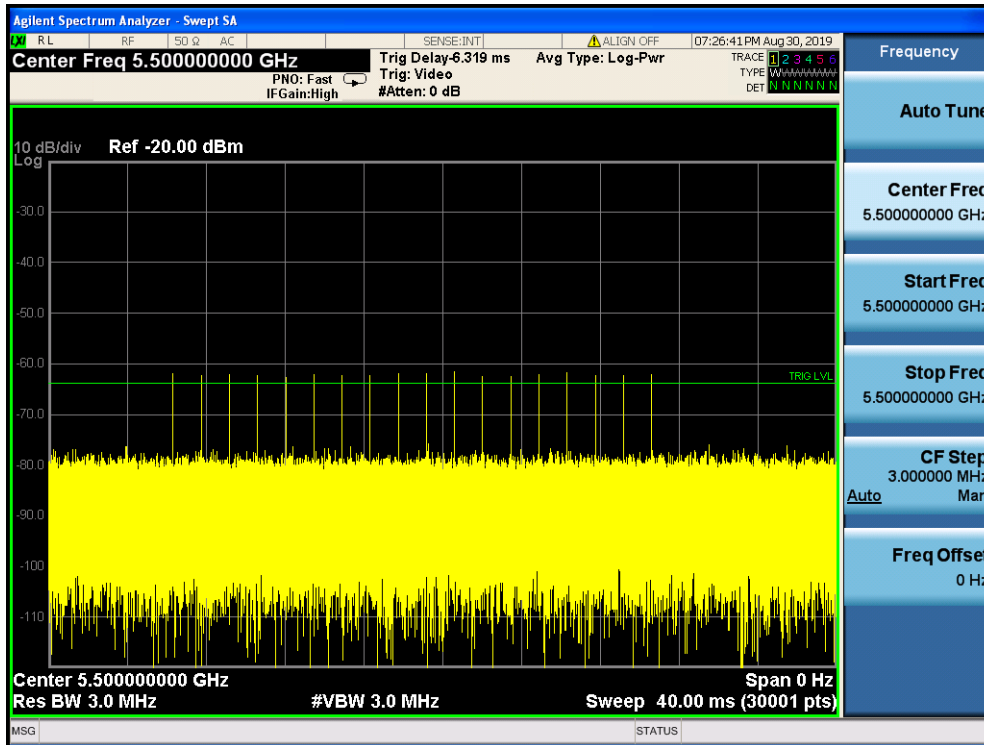

5530.000000MHz

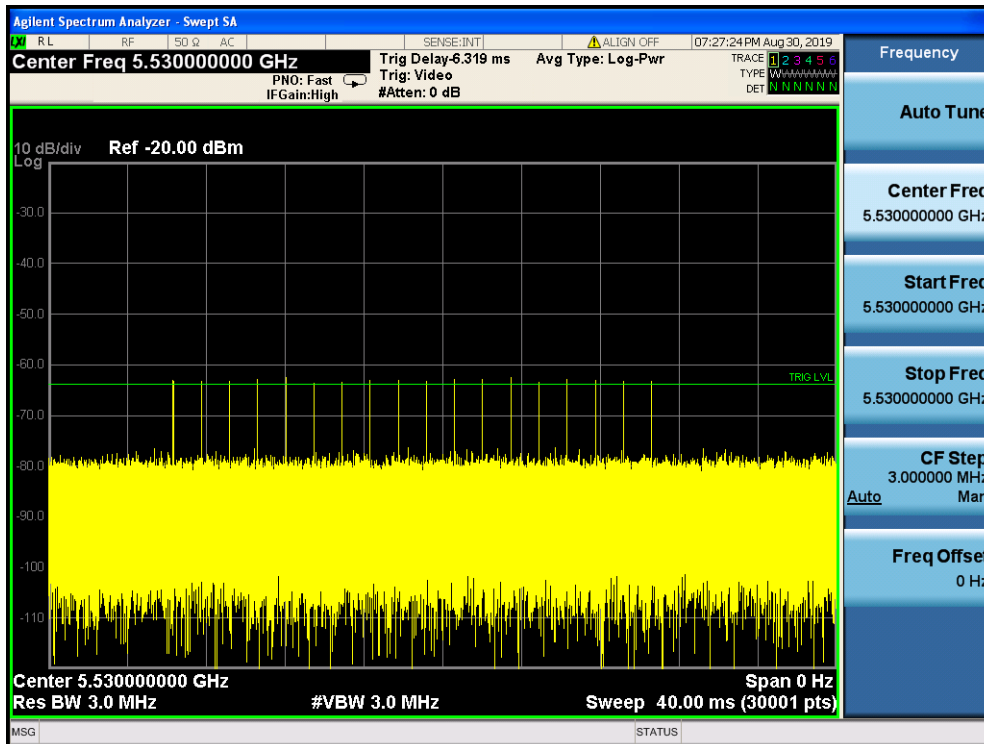

4.10.8 Test Deviation

There is no deviation with the original standard.

TEST REPORT

10.11.1 Test Procedures

1. The radar pulse generator is setup to provide a pulse at frequency that the Master and Client are operating. A type 0 radar pulse with a 1us pulse width and a 1428 us PRI is used for the testing.
2. The vector signal generator is adjusted to provide the radar burst (18 pulses) at a level approximately -62dBm at the antenna of the Master device.
3. An external trigger is provided from the pulse generator to the DFS monitoring system in order to capture the traffic and the occurrence of the radar pulse.
4. A U-NII device operating as a Client Device (EUT) will associate with the Master at same channel. The MPEG file "TestFile.mpg" specified by the FCC is streamed from the "file computer" through the master to the client device (EUT).
5. When a radar burst with a level equal to the DFS Detection Threshold + 1dB is generated on the operating Channel of the U-NII device. At time T0 the Radar Waveform generator sends a Burst of pulse of the radar waveform at Detection Threshold +1dB.
6. Observe the transmission of the EUT at the end of the radar Burst on the Operating Channel. Measure and record the transmissions from the EUT during the observation time. One 20seconds plot is reported for the short pulse Radar Type 0. The plot for the short pulse radar types start at the end of the radar burst.
7. Measurement of the aggregate duration of the Channel Closing Transmission Time method:
Center Frequency: operating frequency
Span: Zero
RBW: 1MHz
VBW: 3MHz
Sweep Time: 32Sec
Detector: Max Peak
Sweep: Single.
8. Measure the EUT for more than 30minutes following the Channel move time to verify the no transmission or beacons occur on this Channel.

4.11.2 Test Setup

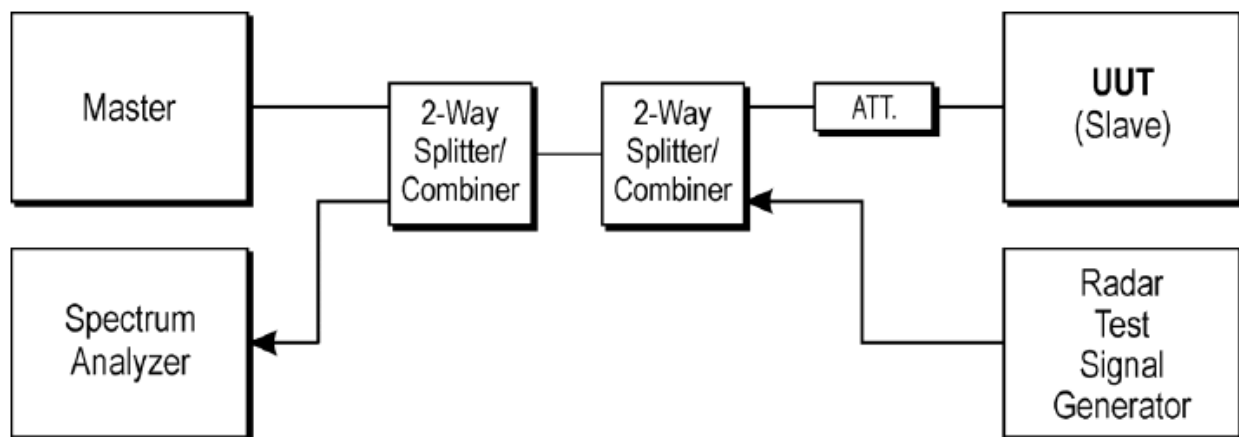

4.11.3 Test Deviation

There is no deviation with the original standard.

TEST REPORT

4.11.4 Test result
Mode : 802.11AC VHT 80

Measurement Summary

DUT Frequency (MHz)	Radar Type No.	Type of Measurement value	Overall Result
5290.000000	0	Channel Move Time	PASS
5290.000000	0	Channel Closing Transmission Time	PASS
5290.000000	0	Non-occupancy period	PASS

Channel Move Time Detailed Results

DUT Frequency (MHz)	Radar Type No.	CMT Tx Time (s)	CMT Limit (s)	CMT Result	CMT Comment
5290.000000	0	0.534	10.000	PASS	Tx Time value is last trailing edge found within sweep. See Note 1.

Channel Closing Transmission Time Detailed Results

DUT Frequency (MHz)	Radar Type No.	CCTT Type of Value	CCTT No. of Pulses found	CCTT Tx Time (ms)	CCTT Tx Time Limit (ms)	CCTT Result
5290.000000	0	remaining 10 second period	5	2.0	200+60	PASS

(continuation of the "Channel Closing Transmission Time Detailed Results" table from column 7 ...)

DUT Frequency (MHz)	CCTT Comment
5290.000000	See Note 1.

Non-occupancy period Detailed Results

DUT Frequency (MHz)	Radar Type No.	NOP No. of Pulses found	NOP No. of Pulses Limit	NOP Tx Time (s)	NOP Tx Time Limit (s)	NOP Result	NOP Comment
5290.000000	0	0	0	0.000	0.000	PASS	

Transmitting Test Detailed Results

DUT Frequency (MHz)	Tx-Test Tx Time (s)	Tx-Test No. of Pulses found	Tx-Test Result	Tx-Test Comment
5290.000000	---		---	not performed / not finished

Additional Information

Note	Description
Note 1:	Because of the radar pulse event at the beginning, the investigation of the trace begins with an offset of 1.5 s conforming to the end of the Radar burst.
Note 2:	-

TEST REPORT

Channel Move Time & Channel Closing Transmission Time

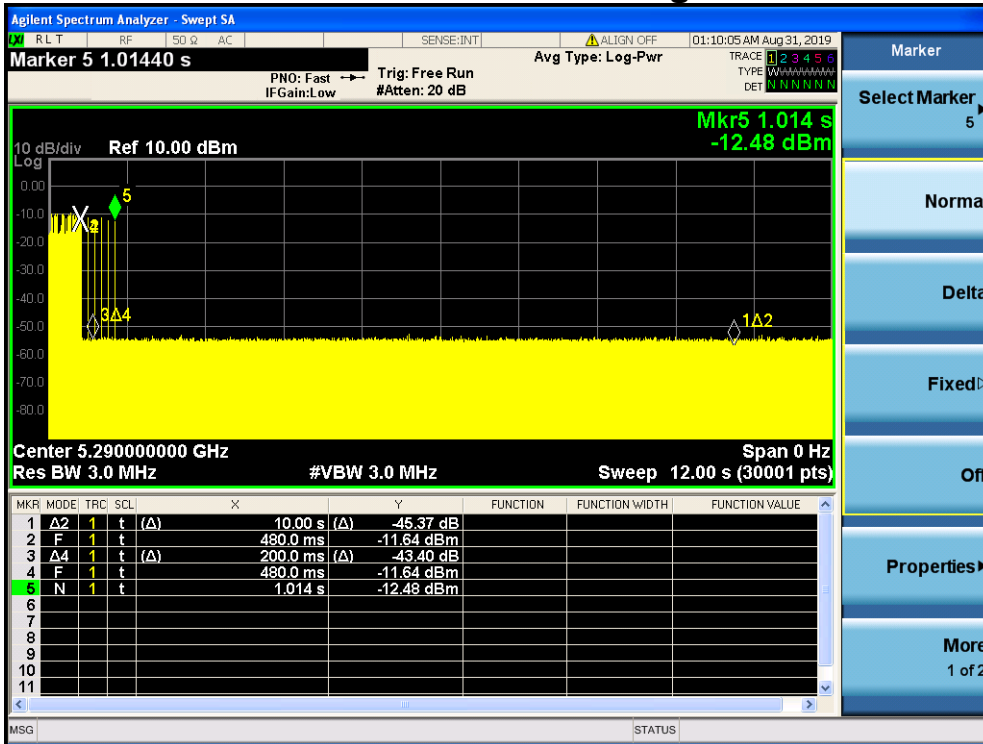

Non-occupancy period

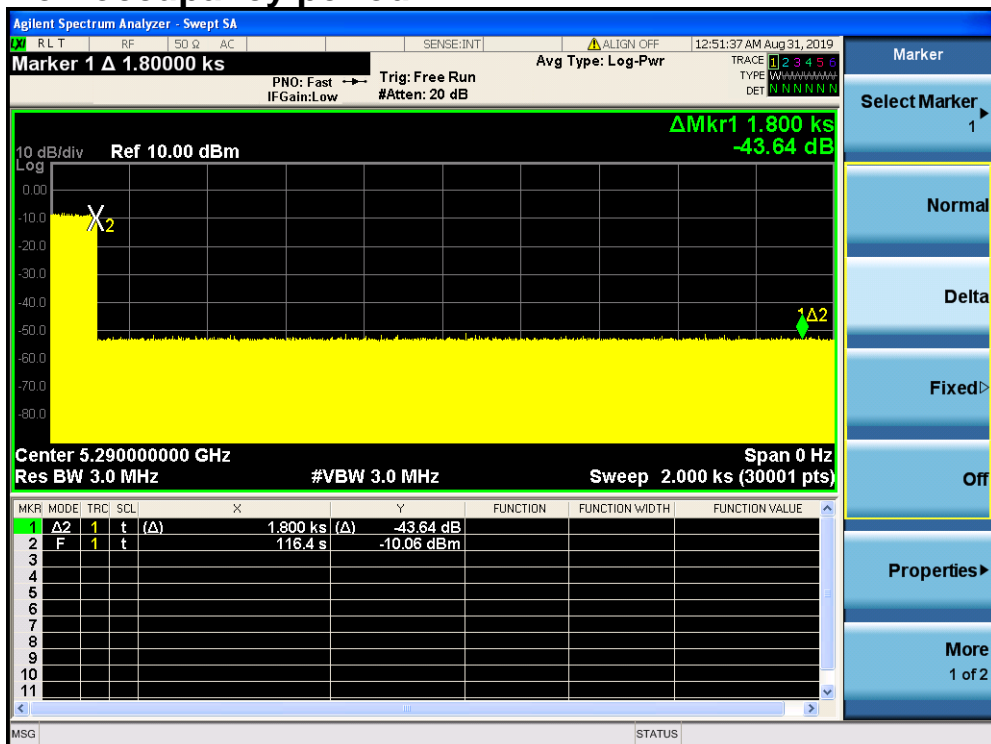

TEST REPORT

Mode : 802.11AC VHT 80

Measurement Summary

DUT Frequency (MHz)	Radar Type No.	Type of Measurement value	Overall Result
5530.000000	0	Channel Move Time	PASS
5530.000000	0	Channel Closing Transmission Time	PASS
5530.000000	0	Non-occupancy period	PASS

Channel Move Time Detailed Results

DUT Frequency (MHz)	Radar Type No.	CMT Tx Time (s)	CMT Limit (s)	CMT Result	CMT Comment
5530.000000	0	0.5328	10.000	PASS	Tx Time value is last trailing edge found within sweep. See Note 1.

Channel Closing Transmission Time Detailed Results

DUT Frequency (MHz)	Radar Type No.	CCTT Type of Value	CCTT No. of Pulses found	CCTT Tx Time (ms)	CCTT Tx Time Limit (ms)	CCTT Result
5530.000000	0	remaining 10 second period	6	2.4	200+60	PASS

(continuation of the "Channel Closing Transmission Time Detailed Results" table from column 7 ...)

DUT Frequency (MHz)	CCTT Comment
5530.000000	See Note 1.

Non-occupancy period Detailed Results

DUT Frequency (MHz)	Radar Type No.	NOP No. of Pulses found	NOP No. of Pulses Limit	NOP Tx Time (s)	NOP Tx Time Limit (s)	NOP Result	NOP Comment
5530.000000	0	0	0	0.000	0.000	PASS	

Transmitting Test Detailed Results

DUT Frequency (MHz)	Tx-Test Tx Time (s)	Tx-Test No. of Pulses found	Tx-Test Result	Tx-Test Comment
5530.000000	---		---	not performed / not finished

Additional Information

Note	Description
Note 1:	Because of the radar pulse event at the beginning, the investigation of the trace begins with an offset of 1.384 s conforming to the end of the Radar burst.
Note 2:	-

TEST REPORT

Channel Move Time & Channel Closing Transmission Time

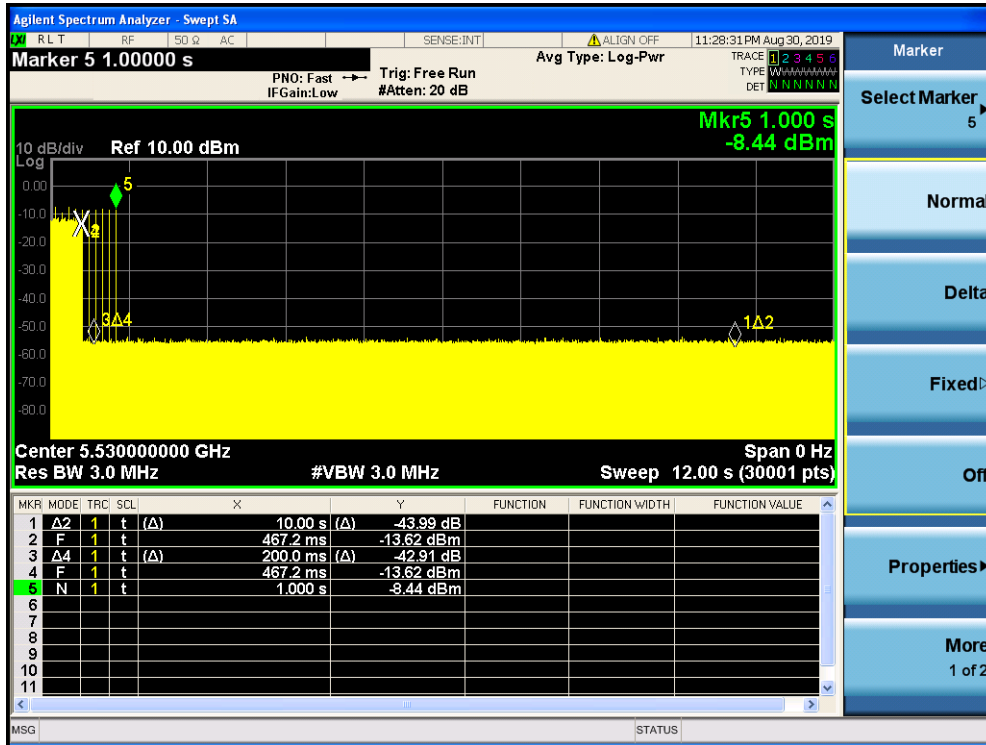

Non-occupancy period



TEST REPORT

Mode: 802.11A

Measurement Summary

DUT Frequency (MHz)	Radar Type No.	Type of Measurement value	Overall Result
5300.000000	0	Channel Move Time	PASS
5300.000000	0	Channel Closing Transmission Time	PASS
5300.000000	0	Non-occupancy period	PASS

Channel Move Time Detailed Results

DUT Frequency (MHz)	Radar Type No.	CMT Tx Time (s)	CMT Limit (s)	CMT Result	CMT Comment
5300.000000	0	0.5380	10.000	PASS	Tx Time value is last trailing edge found within sweep. See Note 1.

Channel Closing Transmission Time Detailed Results

DUT Frequency (MHz)	Radar Type No.	CCTT Type of Value	CCTT No. of Pulses found	CCTT Tx Time (ms)	CCTT Tx Time Limit (ms)	CCTT Result
5300.000000	0	remaining 10 second period	5	2.0	200+60	PASS

(continuation of the "Channel Closing Transmission Time Detailed Results" table from column 7 ...)

DUT Frequency (MHz)	CCTT Comment
5300.000000	See Note 1.

Non-occupancy period Detailed Results

DUT Frequency (MHz)	Radar Type No.	NOP No. of Pulses found	NOP No. of Pulses Limit	NOP Tx Time (s)	NOP Tx Time Limit (s)	NOP Result	NOP Comment
5300.000000	0	0	0	0.000	0.000	PASS	

Transmitting Test Detailed Results

DUT Frequency (MHz)	Tx-Test Tx Time (s)	Tx-Test No. of Pulses found	Tx-Test Result	Tx-Test Comment
5300.000000	---		---	not performed / not finished

Additional Information

Note	Description
Note 1:	Because of the radar pulse event at the beginning, the investigation of the trace begins with an offset of 1.5 s conforming to the end of the Radar burst.
Note 2:	-

TEST REPORT

Channel Move Time & Channel Closing Transmission Time

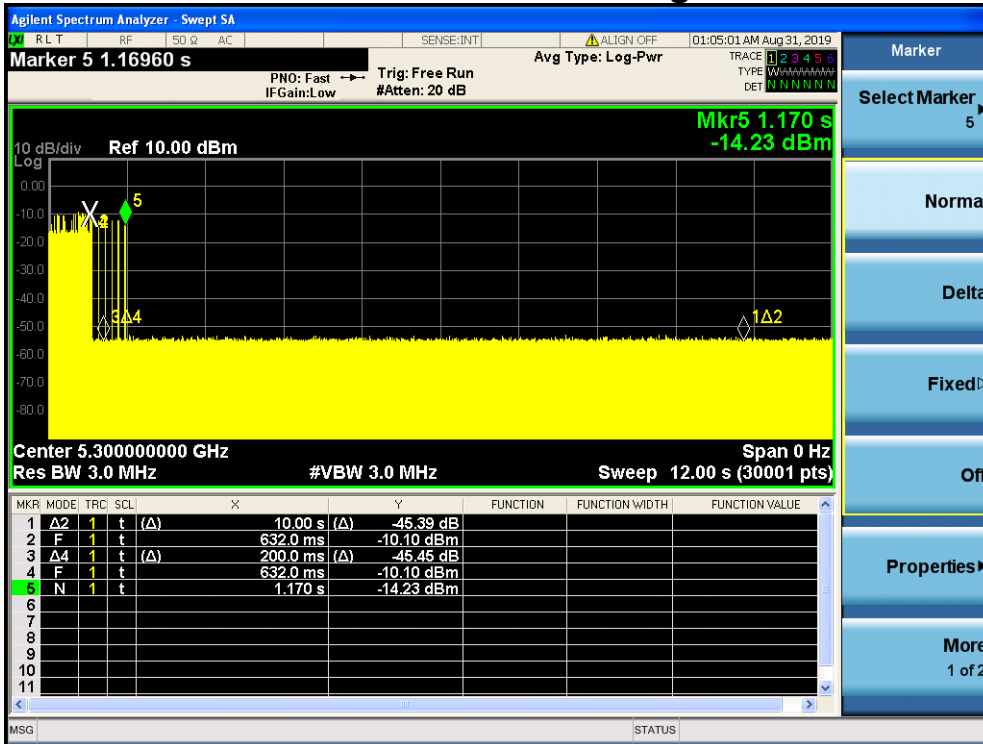

Non-occupancy period

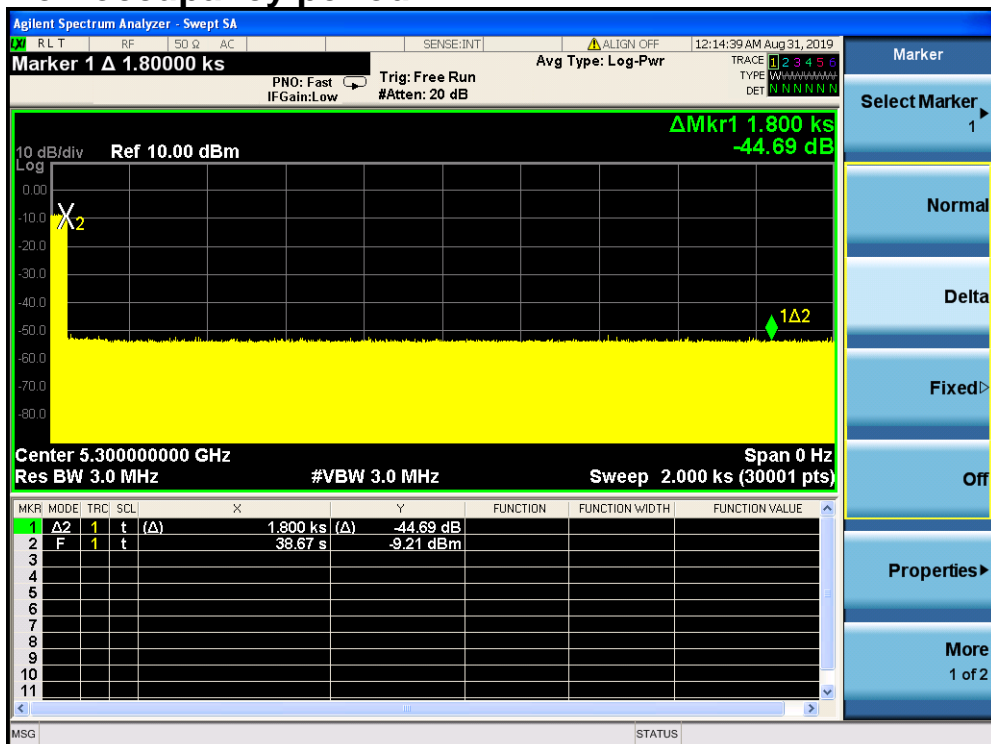

TEST REPORT

Mode: 802.11A

Measurement Summary

DUT Frequency (MHz)	Radar Type No.	Type of Measurement value	Overall Result
5500.000000	0	Channel Move Time	PASS
5500.000000	0	Channel Closing Transmission Time	PASS
5500.000000	0	Non-occupancy period	PASS

Channel Move Time Detailed Results

DUT Frequency (MHz)	Radar Type No.	CMT Tx Time (s)	CMT Limit (s)	CMT Result	CMT Comment
5500.000000	0	0.5208	10.000	PASS	Tx Time value is last trailing edge found within sweep. See Note 1.

Channel Closing Transmission Time Detailed Results

DUT Frequency (MHz)	Radar Type No.	CCTT Type of Value	CCTT No. of Pulses found	CCTT Tx Time (ms)	CCTT Tx Time Limit (ms)	CCTT Result
5500.000000	0	remaining 10 second period	5	2.0	200+60	PASS

(continuation of the "Channel Closing Transmission Time Detailed Results" table from column 7 ...)

DUT Frequency (MHz)	CCTT Comment
5530.000000	See Note 1.

Non-occupancy period Detailed Results

DUT Frequency (MHz)	Radar Type No.	NOP No. of Pulses found	NOP No. of Pulses Limit	NOP Tx Time (s)	NOP Tx Time Limit (s)	NOP Result	NOP Comment
5500.000000	0	0	0	0.000	0.000	PASS	

Transmitting Test Detailed Results

DUT Frequency (MHz)	Tx-Test Tx Time (s)	Tx-Test No. of Pulses found	Tx-Test Result	Tx-Test Comment
5500.000000	---		---	not performed / not finished

Additional Information

Note	Description
Note 1:	Because of the radar pulse event at the beginning, the investigation of the trace begins with an offset of 1.384 s conforming to the end of the Radar burst.
Note 2:	-

TEST REPORT

Channel Move Time & Channel Closing Transmission Time

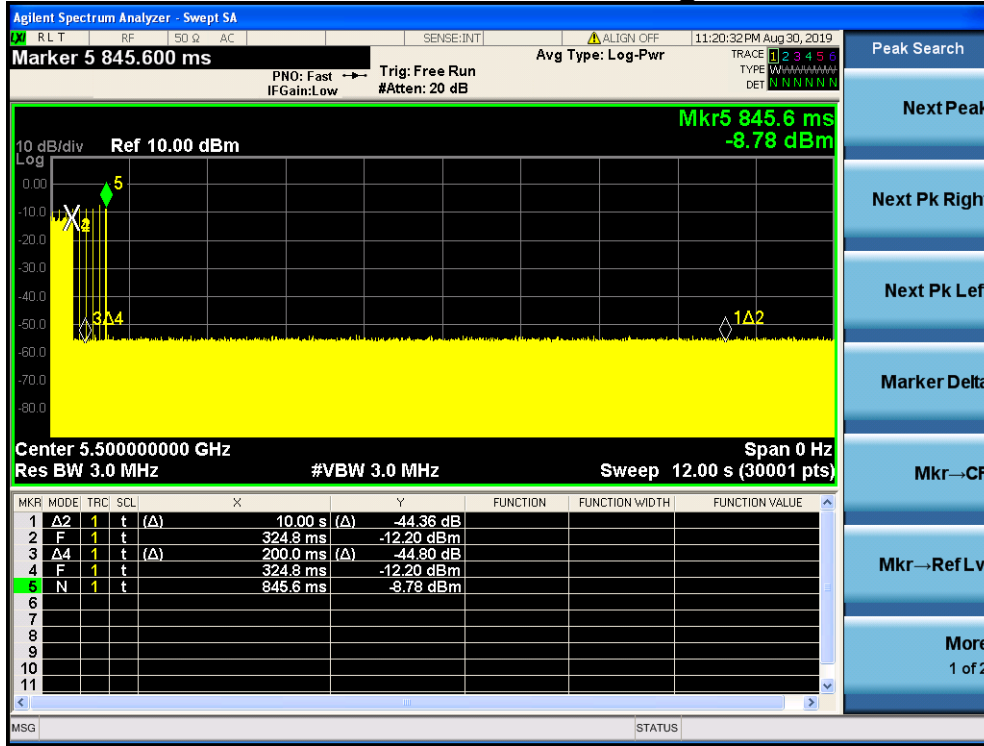

Non-occupancy period

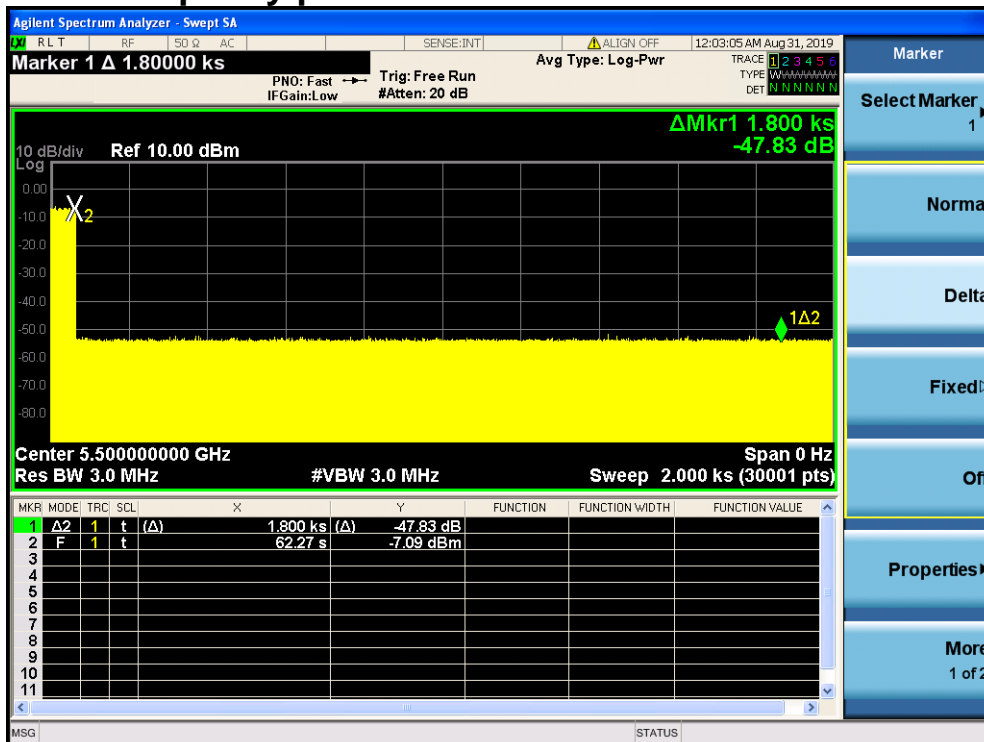

TEST REPORT

5.0 EQUIPMENT LIST

1) Radiated Emissions Test

Used	Registration No.	Equipment	Manufacturer	Model No.	Serial Number	Cal. date (mm dd, yyyy)	Cal. Due date (mm dd, yyyy)
<input checked="" type="checkbox"/>	UTTL-E010	3M Chamber & Accessory Equipment	ETS-LINDGREN	3M	N/A	Dec. 03, 2018	Dec. 03, 2021
<input checked="" type="checkbox"/>	UTTL-E026	Receiver	R&S	ESIB26	100114	Nov. 24, 2018	Nov. 24, 2019
<input checked="" type="checkbox"/>	UTTL-E013	Loop Antenna	ETS-LINDGREN	6502	00202525	Dec. 03, 2018	Dec. 03, 2019
<input checked="" type="checkbox"/>	UTTL-E014	Broadband Antenna	ETS-LINDGREN	3142E	00201566	Dec. 08, 2018	Dec. 08, 2019
<input checked="" type="checkbox"/>	UTTL-E039	6dB Attenuator	Talent	RA6A5-N-18	18103001	Dec. 08, 2018	Dec. 08, 2019
<input checked="" type="checkbox"/>	UTTL-E043	Preamplifier	HP	8447F	2805A02960	Nov. 24, 2018	Nov. 24, 2019
<input checked="" type="checkbox"/>	UTTL-E017	Horn Antenna (Pre-amplifier)	ETS-LINDGREN	3117-PA	00201874	May 22, 2018	May 18, 2020
<input checked="" type="checkbox"/>	N/A	Multi device Controller	ETS-LINDGREN	7006-001	00160105	N/A	N/A
<input checked="" type="checkbox"/>	N/A	Test Software	Audix	e3	Software Version: 9.160333		

2) Conducted Emissions Test

Used	Registration No.	Equipment	Manufacturer	Model No.	Serial Number	Cal. date (mm dd, yyyy)	Cal. Due date (mm dd, yyyy)
<input checked="" type="checkbox"/>	UTTL-E005	Receiver	R&S	ESR7	1316.3003K07-101181-K3	Nov. 24, 2018	Nov. 24, 2019
<input checked="" type="checkbox"/>	UTTL-E007	Pulse Limiter	R&S	ESH3-Z2	0357.8810.54	Nov. 24, 2018	Nov. 24, 2019
<input checked="" type="checkbox"/>	UTTL-E003	LISN	R&S	ESH2-Z5	860014/024	Nov. 24, 2018	Nov. 24, 2019
<input checked="" type="checkbox"/>	N/A	Test Software	Audix	e3	Software Version: 9.160323		

TEST REPORT

3) Conductive Measurement Test

Used	Registration No.	Equipment	Manufacturer	Model No.	Serial Number	Cal. date (mm dd, yyyy)	Cal. Due date (mm dd, yyyy)
<input checked="" type="checkbox"/>	UTTL-E032	EXA Spectrum Analyzer	KEYSIGHT	N9010A	MY51440197	Nov. 24, 2018	Nov. 24, 2019
<input checked="" type="checkbox"/>	UTTL-E033	USB Wideband Power Sensor	KEYSIGHT	U2021XA	MY55430035	Nov. 24, 2018	Nov. 24, 2019

END OF TEST REPORT