

TEST REPORT

Report Number: 19071647HKG-001R1

Application for Original Grant of 47 CFR Part 15 Certification

FCC ID: A2HWT9L11

This report supersedes previous report with report number 19071647HKG-001 dated September 20, 2019.
Please refer HEE-S19-0043 Letter issued on November 05, 2019 for amendment/ supersede notification.

Tested, Prepared and Checked by:

Approved by:



Kelvin Liang
Assistant Manager
Shenzhen UnionTrust Quality and
Technology Co., Ltd.

Lee Shui Tim, Tim
Senior Lead Engineer
Intertek Testing Services Hong Kong
Date: November 05, 2019

Intertek's standard Terms and Conditions can be obtained at our website <http://www.intertek.com/terms/>.

The test report only allows to be revised within the retention period unless further standard or the requirement was noticed.

This report is for the exclusive use of Intertek's Client and is provided pursuant to the agreement between Intertek and its Client. Intertek's responsibility and liability are limited to the terms and conditions of the agreement. Intertek assumes no liability to any party, other than to the Client in accordance with the agreement, for any loss, expense or damage occasioned by the use of this report. Only the Client is authorized to permit copying or distribution of this report and then only in its entirety. Any use of the Intertek name or one of its marks for the sale or advertisement of the tested material, product or service must first be approved in writing by Intertek. The observations and test results in this report are relevant only to the sample tested. This report by itself does not imply that the material, product, or service is or has ever been under an Intertek certification program.

© 2017 Intertek

TEST REPORT

GENERAL INFORMATION

Applicant Name:	Alco Electronics Ltd.
Applicant Address:	11/F., Metropole Square, 2 On Yiu Street, Sha Tin, N.T., Hong Kong.
FCC Specification Standard:	FCC Part 15, October 1, 2017 Edition
FCC ID:	A2HWT9L11
FCC Model(s):	WT9L11P44GD51, 100005693
Type of EUT:	Spread Spectrum Transmitter
Description of EUT:	Tablet
Serial Number:	N/A
Sample Receipt Date:	July 31, 2019
Date of Test:	August 23, 2019 to September 10, 2019
Report Date:	November 05, 2019
Environmental Conditions:	Temperature: +10 to 40°C Humidity: 10 to 90%
Conclusion:	Test was conducted by client submitted sample. The submitted sample as received complied with the 47 CFR Part 15 Certification.

TEST REPORT

TABLE OF CONTENTS

1.0	TEST RESULTS SUMMARY & STATEMENT OF COMPLIANCE	4
	1.1 Summary of Test Results	4
	1.2 Statement of Compliance	4
2.0	GENERAL DESCRIPTION	5
	2.1 Product Description.....	5
	2.2 Test Methodology	6
	2.3 Test Facility	6
	2.4 Related Submittal(s) Grants.....	6
3.0	SYSTEM TEST CONFIGURATION	7
	3.1 Justification	7
	3.2 EUT Exercising Software	8
	3.3 Details of EUT and Description of Accessories.....	9
	3.4 Measurement Uncertainty	9
4.0	TEST RESULTS	10
	4.1 Maximum Conducted Output Power at Antenna Terminals.....	10
	4.2 Minimum 6dB RF Bandwidth.....	14
	4.3 Maximum Power Spectral Density.....	40
	4.4 Out of Band Conducted Emissions	66
	4.5 Field Strength Calculation.....	131
	4.6 Transmitter Radiated Emissions in Restricted Bands and Spurious Emissions.....	132
	4.6.1 Radiated Emission Configuration Photograph	132
	4.6.2 Radiated Emission Data	132
	4.6.3 Radiated Emission Test Setup	190
	4.6.4 Transmitter Duty Cycle Calculation	191
	4.7 AC Power Line Conducted Emission.....	192
	4.7.1 AC Power Line Conducted Emission Configuration Photograph	192
	4.7.2 AC Power Line Conducted Emission Data.....	192
	4.7.3 Conducted Emission Test Setup	195
5.0	EQUIPMENT LIST	196

TEST REPORT

1.0 TEST RESULTS SUMMARY & STATEMENT OF COMPLIANCE

1.1 Summary of Test Results

Test Items	FCC Part 15 Section	Results	Details See Section
Antenna Requirement	15.203	Pass	2.1
Max. Conducted Output Power (Peak)	15.247(b)(3)&(4)	Pass	4.1
Min. 6dB RF Bandwidth	15.247(a)(2)	Pass	4.2
Max. Power Density (average)	15.247(e)	Pass	4.3
Out of Band Antenna Conducted Emission	15.247(d)	Pass	4.4
Radiated Emission in Restricted Bands and Spurious Emissions	15.247(d), 15.209 & 15.109	Pass	4.6
AC Power Line Conducted Emission	15.207 & 15.107	Pass	4.7

Note: Pursuant to FCC Part 15 Section 15.215(c), the 20dB bandwidth of the emission was contained within the frequency band designated (mentioned as above) which the EUT operated. The effects, if any, from frequency sweeping, frequency hopping, other modulation techniques and frequency stability over expected variations in temperature and supply voltage were considered.

1.2 Statement of Compliance

The equipment under test is found to be complying with the following standard:

FCC Part 15, October 1, 2017 Edition

TEST REPORT

2.0 GENERAL DESCRIPTION

2.1 Product Description

The Tablet WT9L11P44GD51 is a Law enforcement recorder.

The Equipment Under Test (EUT) operates at frequency range of 2412MHz to 2472MHz with 13 channels.

For 802.11b mode, it operates at frequency range of 2412.000MHz to 2472.000MHz with 13 channels. It transmits via Direct-sequence spread spectrum (DSSS) modulation. Maximum bit rate can be up to 11Mbps.

For 802.11g mode, it operates at frequency range of 2412.000MHz to 2472.000MHz with 13 channels. It transmits via Orthogonal Frequency Division Multiplexing (OFDM) modulation. Maximum bit rate can be up to 54Mbps.

For 802.11n (with 20MHz bandwidth) mode, it operates at frequency range of 2412.000MHz to 2472.000MHz with 13 channels. It transmits via Orthogonal Frequency Division Multiplexing (OFDM) modulation. Maximum bit rate can support up to 65Mbps.

For 802.11n (with 40MHz bandwidth) mode, it operates at frequency range of 2422.000MHz to 2462.000MHz with 11 channels. It transmits via Orthogonal Frequency Division Multiplexing (OFDM) modulation. Maximum bit rate can support up to 135Mbps.

The EUT is power by a battery.

The antenna(s) used in the EUT is integral, and the test sample is a prototype.

The Model: 100005693 is the same as the Model: WT9L11P44GD51 in electronics/electrical designs including software & firmware, PCB layout and construction design/physical design/enclosure as declared by client. The only differences between these models are brand name and model number to be sold for marketing purpose as declared by client.

TEST REPORT

2.2 Test Methodology

Both AC power line-conducted and radiated emission measurements were performed according to the procedures in ANSI C63.10 (2013). Preliminary radiated scans and all radiated measurements were performed in radiated emission test sites. All Radiated tests were performed at an antenna to EUT distance of 3 meters, unless stated otherwise in the "**Justification Section**" of this Application. Antenna port conducted measurements were performed according to ANSI C63.10 (2013) and KDB Publication No.558074 D01 v05r02 All other measurements were made in accordance with the procedures in 47 CFR Part 2.

2.3 Test Facility

The radiated emission test site and antenna port conducted measurement facility used to collect the radiated data and conductive data are at 16/F, Block A, Building 6, Baoneng Science and Technology Park, Qingxiang Road No.1, Longhua New District, Shenzhen, China. This test facility and site measurement data have been fully placed on file with the FCC.

2.4 Related Submittal(s) Grants

This is a single application for certification of a transmitter.

TEST REPORT

3.0 SYSTEM TEST CONFIGURATION

3.1 Justification

For radiated emissions testing, the equipment under test (EUT) was setup to transmit / receive continuously to simplify the measurement methodology. Care was taken to ensure proper power supply voltages during testing. During testing, all cables (if any) were manipulated to produce worst case emissions.

The EUT was powered by a battery.

For the measurements, the EUT was attached to a plastic stand if necessary and placed on the wooden turntable. If the base unit attached to peripherals, they were connected and operational (as typical as possible).

The signal was maximized through rotation and placement in the three orthogonal axes. The antenna height and polarization were varied during the search for maximum signal level. The antenna height was varied from 1 to 4 meters. Radiated emissions were taken at three meters unless the signal level was too low for measurement at that distance. If necessary, a pre-amplifier was used and/or the test was conducted at a closer distance.

For any intentional radiator powered by AC power line, measurements of the radiated signal level of the fundamental frequency component of the emission was performed with the supply voltage varied between 85% and 115% of the nominal rated supply voltage.

Radiated emission measurement for transmitter were performed from the lowest radio frequency signal generated in the device which is greater than 9 kHz to the tenth harmonic of the highest fundamental frequency or to 40 GHz, whichever is lower.

Emission that are directly caused by digital circuits in the transmit path and transmitter portion were measured, and the limit are according to FCC Part 15 Section 15.209. Digital circuitries used to control additional functions other than the operation of the transmitter are subject to FCC Part 15 Section 15.109.

TEST REPORT

3.1 Justification – Cont'd

Detector function for radiated emissions was in peak mode. Average readings, when required, were taken by measuring the duty cycle of the equipment under test and subtracting the corresponding amount in dB from the measured peak readings. A detailed description for the calculation of the average factor can be found in section 4.8.3.

Determination of pulse desensitization was made according to *Hewlett Packard Application Note 150-2, Spectrum Analysis... Pulsed RF*. The effective period (Teff) was referred to Exhibit 4.8.3. With the resolution bandwidth 1MHz and spectrum analyzer IF bandwidth 3dB, the pulse desensitization factor was 0dB.

For AC line conducted emission test, the EUT along with its peripherals were placed on a 1.0m(W)x1.5m(L) and 0.8m in height wooden table and the EUT was adjusted to maintain a 0.4 meter space from a vertical reference plane. The EUT was connected to power mains through a line impedance stabilization network (LISN), which provided 50ohm coupling impedance for measuring instrument. The LISN housing, measuring instrument case, reference ground plane, and vertical ground plane were bounded together. The excess power cable between the EUT and the LISN was bundled.

All connecting cables of EUT and peripherals were manipulated to find the maximum emission.

Different data rates have been tested. Worst case is reported only.

All relevant operation modes have been tested, and the worst case data is included in this report.

All data rates were tested under normal mode of WiFi. Only the worst-case data is shown in the report for DSSS and OFDM

3.2 EUT Exercising Software

The EUT exercise program (if any) used during radiated and conducted testing was designed to exercise the various system components in a manner similar to a typical use.

TEST REPORT

3.3 Details of EUT and Description of Accessories

Details of EUT:

AC adaptor (provided with the unit) was used to power the device. Their description are listed below.

- (1) An AC adaptor (100V to 240V, Model: DBS018A-1201500U) (Provided by Applicant)
- (2) An AC adaptor (100V to 240V, Model: DCT18W120150US-A0) (Provided by Applicant)
- (3) A Lithium-ion Polymer Rechargeable Battery (3.7V, 3750mAh, Model: PT2890128) (Provided by Applicant)

Description of Accessories:

- (1) Keyboard (Provided by Applicant)

3.4 Measurement Uncertainty

When determining of the test conclusion, the Measurement Uncertainty of test at a level of confidence of 95% has been considered. The values of the Measurement uncertainty:

No.	Item	Measurement Uncertainty
1	Conducted emission 9KHz-150KHz	±3.8 dB
2	Conducted emission 150KHz-30MHz	±3.4 dB
3	Radiated emission 9KHz-30MHz	±4.9 dB
4	Radiated emission 30MHz-1GHz	±4.7 dB
5	Radiated emission 1GHz-18GHz	±5.1 dB
6	Radiated emission 18GHz-26GHz	±5.2 dB
7	Radiated emission 26GHz-40GHz	±5.2 dB

Uncertainty and Compliance - Unless the standard specifically states that measured values are to be extended by the measurement uncertainty in determining compliance, all compliance determinations are based on the actual measured value.

TEST REPORT

4.0 TEST RESULTS

4.1 Maximum Conducted (peak) Output Power at Antenna Terminals

RF Conduct Measurement Test Setup

The figure below shows the test setup, which is utilized to make these measurements.

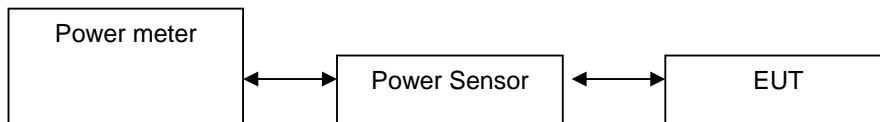

The antenna port of the EUT was connected to the input of a spectrum analyzer.

- The antenna power of the EUT was connected to the input of a power meter. Power was read directly and cable loss correction was added to the reading to obtain power at the EUT antenna terminals. The measurement procedure 9.1.2 was used.
- The EUT should be configured to transmit continuously (at a minimum duty cycle of 98%) at full power over the measurement duration. The measurement procedure AVG1 was used.

IEEE 802.11b (DSSS, 1 Mbps)

Antenna Gain (Ant. 1) = -0.1 dBi , Antenna Gain (Ant. 2) = 0.2 dBi

Frequency (MHz)		Output in dBm (PEAK)		Output in mWatt	
		Ant. 1	Ant. 2	Ant. 1	Ant. 2
Low Channel:	2412	17.05	18.47	50.70	70.31
Middle Channel:	2437	17.35	18.39	54.33	69.02
High Channel-1:	2462	17.57	18.42	57.15	69.50
High Channel-2:	2467	17.17	18.35	52.12	68.39
High Channel-3:	2472	17.22	18.44	52.72	69.82

IEEE 802.11g (OFDM, 6 Mbps)

Antenna Gain (Ant. 1) = -0.1 dBi , Antenna Gain (Ant. 2) = 0.2 dBi

Frequency (MHz)		Output in dBm (PEAK)		Output in mWatt	
		Ant. 1	Ant. 2	Ant. 1	Ant. 2
Low Channel:	2412	17.65	19.31	58.21	85.31
Middle Channel:	2437	17.92	19.22	61.94	83.56
High Channel-1:	2462	18.18	19.74	65.77	94.19
High Channel-2:	2467	18.22	19.69	66.37	93.11
High Channel-3:	2472	18.25	19.72	66.83	93.76

TEST REPORT

4.1 Maximum Conducted Output Power at Antenna Terminals – Cont'd

IEEE 802.11n (20MHz) (OFDM, MCS0)

Antenna Gain (Ant. 1) = -0.1 dBi , Antenna Gain (Ant. 2) = 0.2 dBi

Frequency (MHz)		Output in dBm (PEAK)		Output in mWatt	
		Ant. 1	Ant. 2	Ant. 1	Ant. 2
Low Channel:	2412	17.46	19.24	55.72	83.95
Middle Channel:	2437	18.59	19.18	72.28	82.79
High Channel-1:	2462	18.01	19.72	63.24	93.76
High Channel-2:	2467	18.08	19.67	64.27	92.68
High Channel-3:	2472	18.76	19.69	75.16	93.11

IEEE 802.11n (40MHz) (OFDM, MCS0)

Antenna Gain (Ant. 1) = -0.1 dBi , Antenna Gain (Ant. 2) = 0.2 dBi

Frequency (MHz)		Output in dBm (PEAK)		Output in mWatt	
		Ant. 1	Ant. 2	Ant. 1	Ant. 2
Low Channel:	2422	17.31	19.01	53.83	79.62
Middle Channel:	2437	18.33	18.95	68.08	78.52
High Channel-1:	2452	18.41	18.89	69.34	77.45
High Channel-2:	2457	17.66	19.42	58.34	87.50
High Channel-3:	2462	18.53	19.45	71.29	88.10

TEST REPORT

4.1 Maximum Conducted Output Power at Antenna Terminals – Cont'd

For maximum e.i.r.p.

IEEE 802.11b (DSSS, 1 Mbps)

Antenna Gain (Ant. 1) = -0.1 dBi , Antenna Gain (Ant. 2) = 0.2 dBi

Frequency (MHz)		Output in dBm		Output in mWatt	
		Ant. 1	Ant. 2	Ant. 1	Ant. 2
Low Channel:	2412	16.95	18.67	49.55	73.62
Middle Channel:	2437	17.25	18.59	53.09	72.28
High Channel-1:	2462	17.47	18.62	55.85	72.78
High Channel-2:	2467	17.07	18.55	50.93	71.61
High Channel-3:	2472	17.12	18.64	51.52	73.11

IEEE 802.11g (OFDM, 6 Mbps)

Antenna Gain (Ant. 1) = -0.1 dBi , Antenna Gain (Ant. 2) = 0.2 dBi

Frequency (MHz)		Output in dBm		Output in mWatt	
		Ant. 1	Ant. 2	Ant. 1	Ant. 2
Low Channel:	2412	17.55	19.51	56.89	89.33
Middle Channel:	2437	17.82	19.42	60.53	87.50
High Channel-1:	2462	18.08	19.94	64.27	98.63
High Channel-2:	2467	18.12	19.89	64.86	97.50
High Channel-3:	2472	18.15	19.92	65.31	98.17

IEEE 802.11n (20MHz) (OFDM, MCS0)

Antenna Gain (Ant. 1) = -0.1 dBi , Antenna Gain (Ant. 2) = 0.2 dBi

Frequency (MHz)		Output in dBm		Output in mWatt	
		Ant. 1	Ant. 2	Ant. 1	Ant. 2
Low Channel:	2412	17.36	19.44	54.45	87.90
Middle Channel:	2437	18.49	19.38	70.63	86.70
High Channel-1:	2462	17.91	19.92	61.80	98.17
High Channel-2:	2467	17.98	19.87	62.81	97.05
High Channel-3:	2472	18.66	19.89	73.45	97.50

TEST REPORT

4.1 Maximum Conducted Output Power at Antenna Terminals – Cont'd

Cable loss : 0.5 dB External Attenuation : 10 dB

Cable loss, external attenuation: included in OFFSET function
 added to SA raw reading

Ant. 1:

IEEE 802.11b (DSSS, 1 Mbps)

max. conducted (peak) output level = 19.27 dBm

IEEE 802.11g (OFDM, 9 Mbps)

max. conducted (peak) output level = 19.95 dBm

IEEE 802.11n (20MHz) (OFDM, MCS0)

max. conducted (peak) output level = 20.46 dBm

IEEE 802.11n (40MHz) (OFDM, MCS0)

max. conducted (peak) output level = 20.23 dBm

Ant. 2:

IEEE 802.11b (DSSS, 1 Mbps)

max. conducted (peak) output level = 20.27 dBm

IEEE 802.11g (OFDM, 9 Mbps)

max. conducted (peak) output level = 21.54 dBm

IEEE 802.11n (20MHz) (OFDM, MCS0)

max. conducted (peak) output level = 21.52 dBm

IEEE 802.11n (40MHz) (OFDM, MCS0)

max. conducted (peak) output level = 21.25 dBm

Limits:

1W (30dBm) for antennas with gains of 6dBi or less

___W (___dBm) for antennas with gains more than 6dBi

The plots of conducted output power are saved as below.

TEST REPORT

4.2 Minimum 6dB RF Bandwidth

The antenna port of the EUT was connected to the input of a spectrum analyzer. The EBW measurement procedure was used. A PEAK output reading was taken, a DISPLAY line was drawn 6dB lower than PEAK level. The 6dB bandwidth was determined from where the channel output spectrum intersected the display line.

IEEE 802.11b (DSSS, 1 Mbps)

Frequency (MHz)	6dB Bandwidth (MHz)	
	Ant. 1	Ant. 2
Low Channel:	2412	10.10
Middle Channel:	2437	10.10
High Channel-1:	2462	10.10
High Channel-2:	2467	10.10
High Channel-3:	2472	10.10

IEEE 802.11g (OFDM, 6 Mbps)

Frequency (MHz)	6dB Bandwidth (MHz)	
	Ant. 1	Ant. 2
Low Channel:	2412	15.17
Middle Channel:	2437	15.17
High Channel-1:	2462	15.17
High Channel-2:	2467	15.17
High Channel-3:	2472	15.17

IEEE 802.11n (20MHz) (OFDM, MCS0)

Frequency (MHz)	6dB Bandwidth (MHz)	
	Ant. 1	Ant. 2
Low Channel:	2412	15.17
Middle Channel:	2437	15.17
High Channel-1:	2462	15.17
High Channel-2:	2467	15.17
High Channel-3:	2472	15.17

TEST REPORT

IEEE 802.11n (40MHz) (OFDM, MCS0)

Frequency (MHz)	6dB Bandwidth (MHz)		
	Ant. 1	Ant. 2	
Low Channel:	2422	35.20	35.20
Middle Channel:	2437	35.18	35.20
High Channel-1:	2452	35.19	35.18
High Channel-2:	2457	35.19	35.21
High Channel-3:	2462	35.19	35.20

Limits

6 dB bandwidth shall be at least 500kHz

The plots of 6dB RF bandwidth are saved as below.

TEST REPORT

PLOTS OF 6dB RF BANDWIDTH

Ant. 1_802.11b, Lowest Channel



Ant. 1_802.11b, Middle Channel



TEST REPORT

PLOTS OF 6dB RF BANDWIDTH

Ant. 1_802.11b, Highest Channel-1



Ant. 1_802.11b, Highest Channel-2



TEST REPORT

PLOTS OF 6dB RF BANDWIDTH

Ant. 1_802.11b, Highest Channel-3



TEST REPORT

PLOTS OF 6dB RF BANDWIDTH

Ant. 1_802.11g, Lowest Channel



Ant. 1_802.11g, Middle Channel



TEST REPORT

PLOTS OF 6dB RF BANDWIDTH

Ant. 1_802.11g, Highest Channel-1

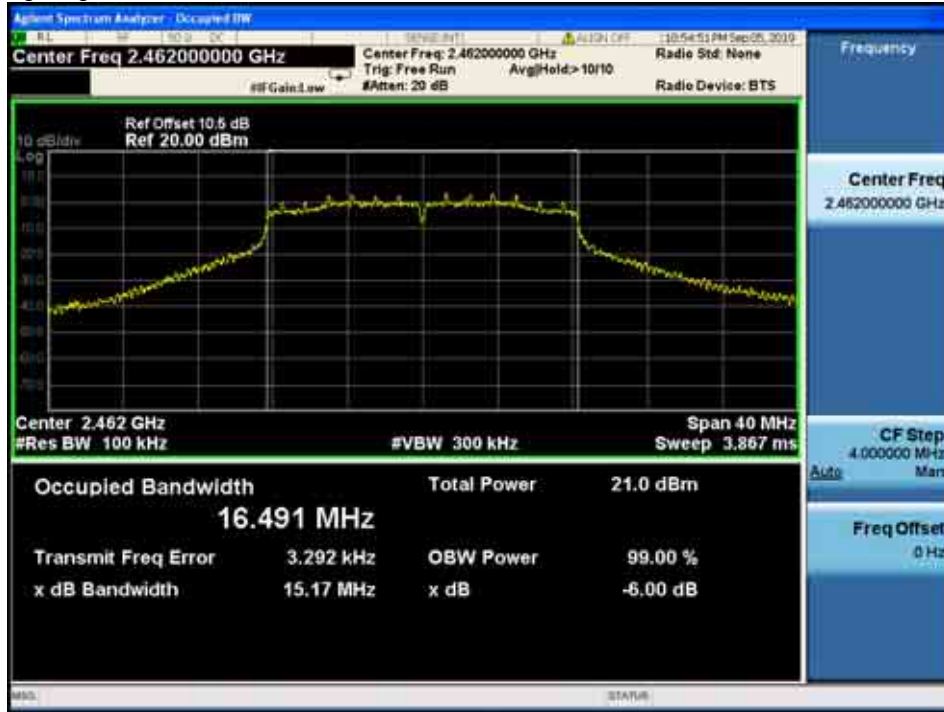

Ant. 1_802.11g, Highest Channel-2



TEST REPORT

PLOTS OF 6dB RF BANDWIDTH

Ant. 1_802.11g, Highest Channel-3



TEST REPORT

PLOTS OF 6dB RF BANDWIDTH

Ant. 1_802.11n (20MHz), Lowest Channel



Ant. 1_802.11n (20MHz), Middle Channel



TEST REPORT

PLOTS OF 6dB RF BANDWIDTH

Ant. 1_802.11n (20MHz), Highest Channel-1

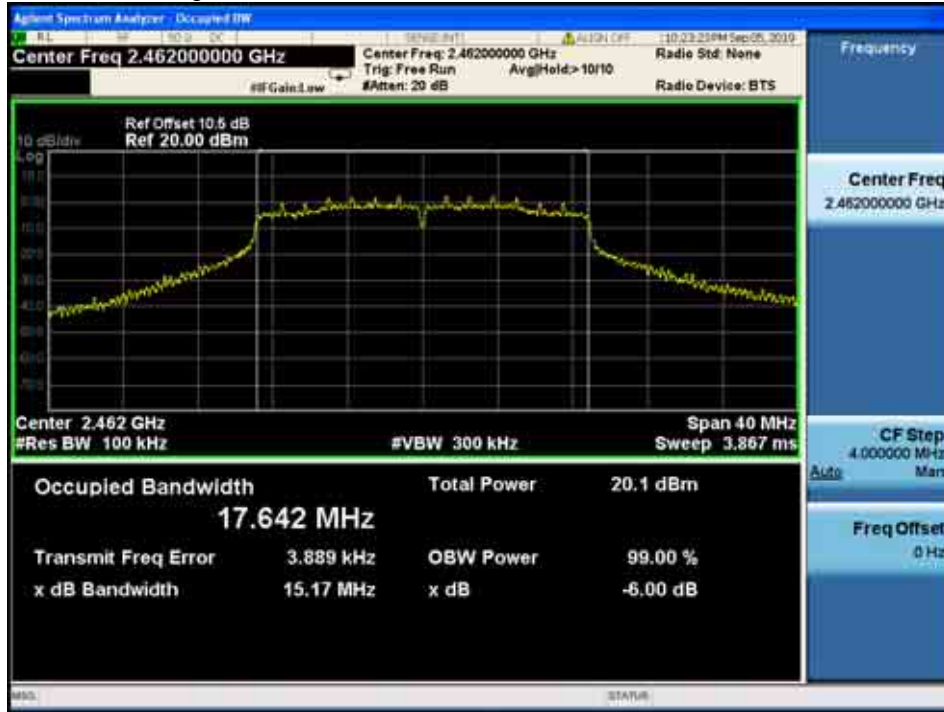

Ant. 1_802.11n (20MHz), Highest Channel-2



TEST REPORT

PLOTS OF 6dB RF BANDWIDTH

Ant. 1_802.11n (20MHz), Highest Channel-3



TEST REPORT

PLOTS OF 6dB RF BANDWIDTH

Ant. 1_802.11n (40MHz), Lowest Channel



Ant. 1_802.11n (40MHz), Middle Channel



TEST REPORT

PLOTS OF 6dB RF BANDWIDTH

Ant. 1_802.11n (40MHz), Highest Channel-1



Ant. 1_802.11n (40MHz), Highest Channel-2



TEST REPORT

PLOTS OF 6dB RF BANDWIDTH

Ant. 1_802.11n (40MHz), Highest Channel-3



TEST REPORT

PLOTS OF 6dB RF BANDWIDTH

Ant. 2_802.11b, Lowest Channel



Ant. 2_802.11b, Middle Channel



TEST REPORT

PLOTS OF 6dB RF BANDWIDTH

Ant. 2_802.11b, Highest Channel-1



Ant. 2_802.11b, Highest Channel-2



TEST REPORT

PLOTS OF 6dB RF BANDWIDTH

Ant. 2_802.11b, Highest Channel-3



TEST REPORT

PLOTS OF 6dB RF BANDWIDTH

Ant. 2_802.11g, Lowest Channel



Ant. 2_802.11g, Middle Channel



TEST REPORT

PLOTS OF 6dB RF BANDWIDTH

Ant. 2_802.11g, Highest Channel-1



Ant. 2_802.11g, Highest Channel-2



TEST REPORT

PLOTS OF 6dB RF BANDWIDTH

Ant. 2_802.11g, Highest Channel-3



TEST REPORT

PLOTS OF 6dB RF BANDWIDTH

Ant. 2_802.11n (20MHz), Lowest Channel



Ant. 2_802.11n (20MHz), Middle Channel



TEST REPORT

PLOTS OF 6dB RF BANDWIDTH

Ant. 2_802.11n (20MHz), Highest Channel-1



Ant. 2_802.11n (20MHz), Highest Channel-2



TEST REPORT

PLOTS OF 6dB RF BANDWIDTH

Ant. 2_802.11n (20MHz), Highest Channel-3



TEST REPORT

PLOTS OF 6dB RF BANDWIDTH

Ant. 2_802.11n (40MHz), Lowest Channel



Ant. 2_802.11n (40MHz), Middle Channel

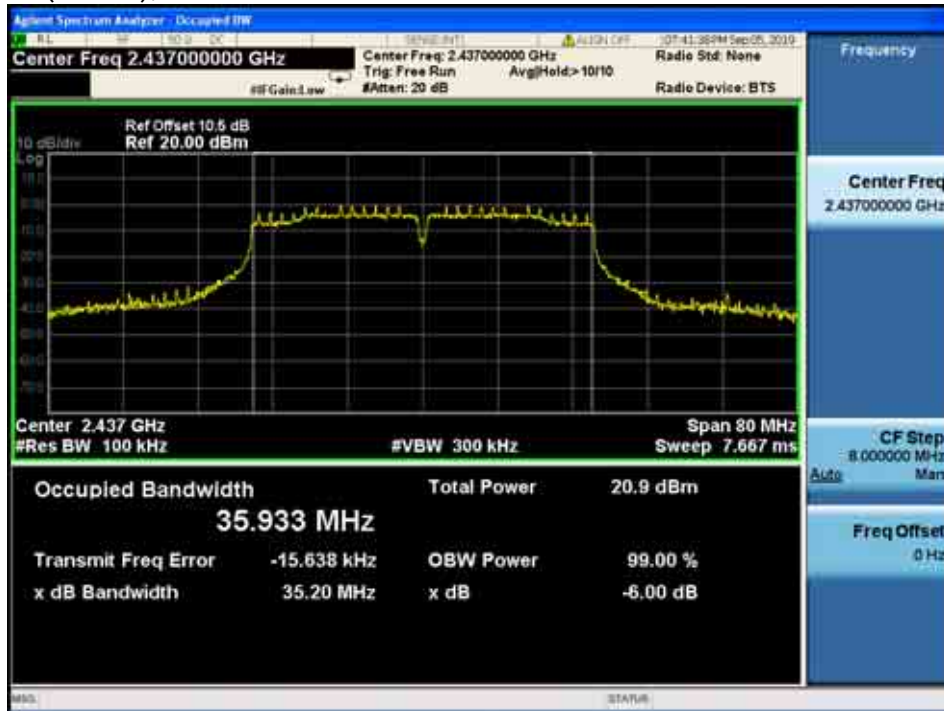

TEST REPORT

PLOTS OF 6dB RF BANDWIDTH

Ant. 2_802.11n (40MHz), Highest Channel-1



Ant. 2_802.11n (40MHz), Highest Channel-2

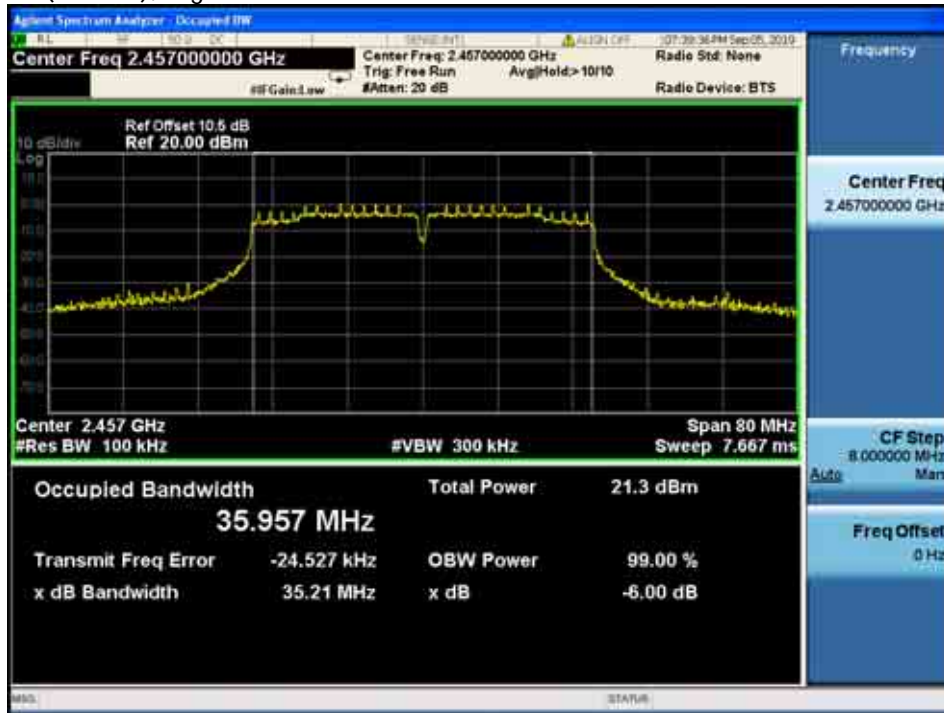

TEST REPORT

PLOTS OF 6dB RF BANDWIDTH

Ant. 2_802.11n (40MHz), Highest Channel-3



TEST REPORT

4.3 Maximum Power Spectral Density

Antenna output of the EUT was coupled directly to spectrum analyzer. The measurement procedure ANSI C63.10-2013 Clause 11.10.2 PKPSD was used. If an external attenuator and/or cable was used, these losses are compensated for using the OFFSET function of the analyser.

IEEE 802.11b (DSSS, 1 Mbps)

Frequency (MHz)		PSD in 3kHz (dBm)	
		Ant. 1	Ant. 2
Low Channel:	2412	-10.297	-8.624
Middle Channel:	2437	-9.890	-8.715
High Channel-1:	2462	-9.526	-8.219
High Channel-2:	2467	-9.556	-8.220
High Channel-3:	2472	-8.718	-7.320

IEEE 802.11g (OFDM, 6 Mbps)

Frequency (MHz)		PSD in 3kHz (dBm)	
		Ant. 1	Ant. 2
Low Channel:	2412	-13.182	-11.240
Middle Channel:	2437	-12.508	-11.182
High Channel-1:	2462	-11.970	-11.501
High Channel-2:	2467	-11.709	-11.406
High Channel-3:	2472	-11.958	-11.579

IEEE 802.11n (20MHz) (OFDM, MCS0)

Frequency (MHz)		PSD in 3kHz (dBm)	
		Ant. 1	Ant. 2
Low Channel:	2412	-13.136	-11.472
Middle Channel:	2437	-11.612	-10.457
High Channel-1:	2462	-11.667	-10.699
High Channel-2:	2467	-12.100	-11.351
High Channel-3:	2472	-11.155	-11.034

IEEE 802.11n (40MHz) (OFDM, MCS0)

Frequency (MHz)		PSD in 3kHz (dBm)	
		Ant. 1	Ant. 2
Low Channel:	2422	-15.652	-14.606
Middle Channel:	2437	-14.292	-14.713
High Channel-1:	2452	-14.184	-13.045
High Channel-2:	2457	-14.020	-13.630
High Channel-3:	2462	-14.686	-14.240

TEST REPORT

Cable Loss: 0.5 dB

Limit:
8dBm

The plots of power spectral density are as below.

TEST REPORT

PLOTS OF POWER SPECTRAL DENSITY

Ant.1_802.11b, Lowest channel



Ant.1_802.11b, Middle channel



TEST REPORT

PLOTS OF POWER SPECTRAL DENSITY

Ant.1_802.11b, Highest channel-1



Ant.1_802.11b, Highest channel-2



TEST REPORT

PLOTS OF POWER SPECTRAL DENSITY

Ant.1_802.11b, Highest channel-3



TEST REPORT

PLOTS OF POWER SPECTRAL DENSITY

Ant.1_802.11g, Lowest channel

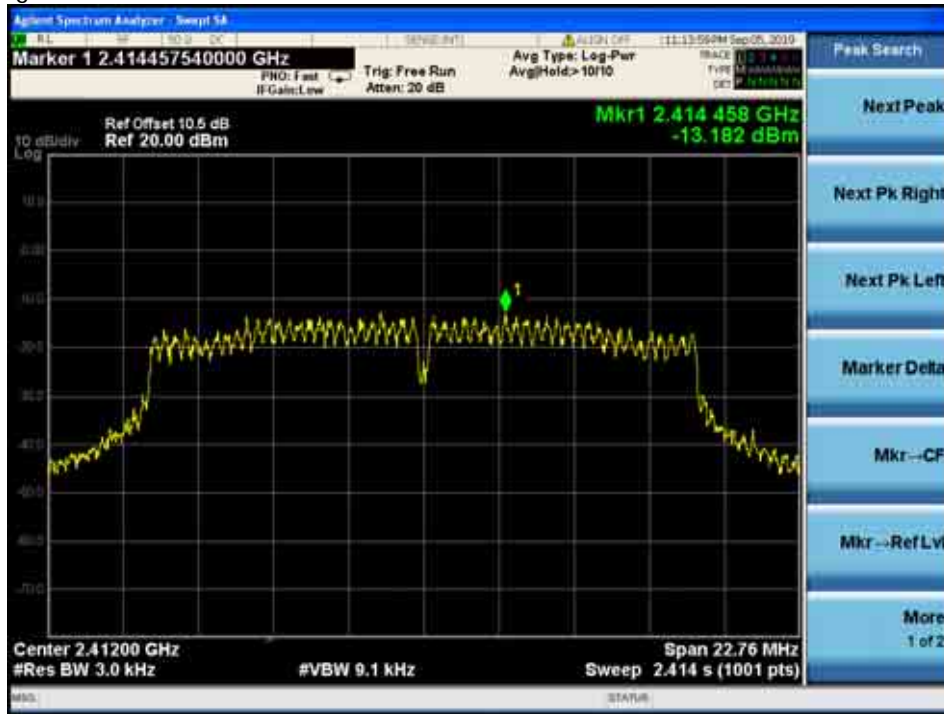

Ant.1_802.11g, Middle channel



TEST REPORT

PLOTS OF POWER SPECTRAL DENSITY

Ant.1_802.11g, Highest channel-1



Ant.1_802.11g, Highest channel-2



TEST REPORT

PLOTS OF POWER SPECTRAL DENSITY

Ant.1_802.11g, Highest channel-3



TEST REPORT

PLOTS OF POWER SPECTRAL DENSITY

Ant.1_802.11n (20MHz), Lowest channel



Ant.1_802.11n (20MHz), Middle channel



TEST REPORT

PLOTS OF POWER SPECTRAL DENSITY

Ant.1_802.11n (20MHz), Highest channel-1



Ant.1_802.11n (20MHz), Highest channel-2



TEST REPORT

PLOTS OF POWER SPECTRAL DENSITY

Ant.1_802.11n (20MHz), Highest channel-3



TEST REPORT

PLOTS OF POWER SPECTRAL DENSITY

Ant.1_802.11n (40MHz), Lowest channel

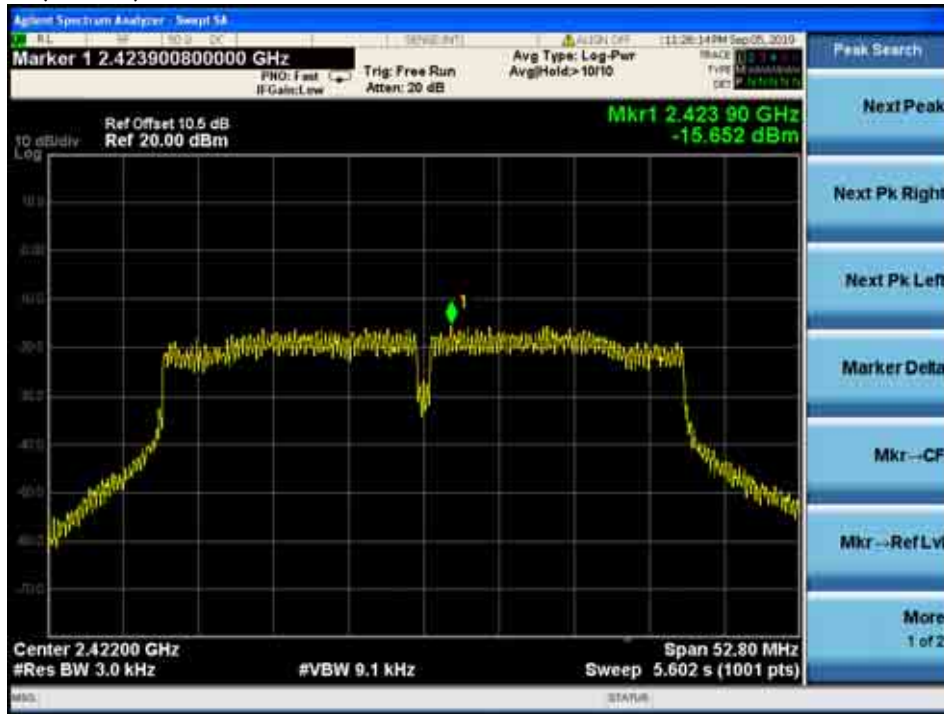

Ant.1_802.11n (40MHz), Middle channel

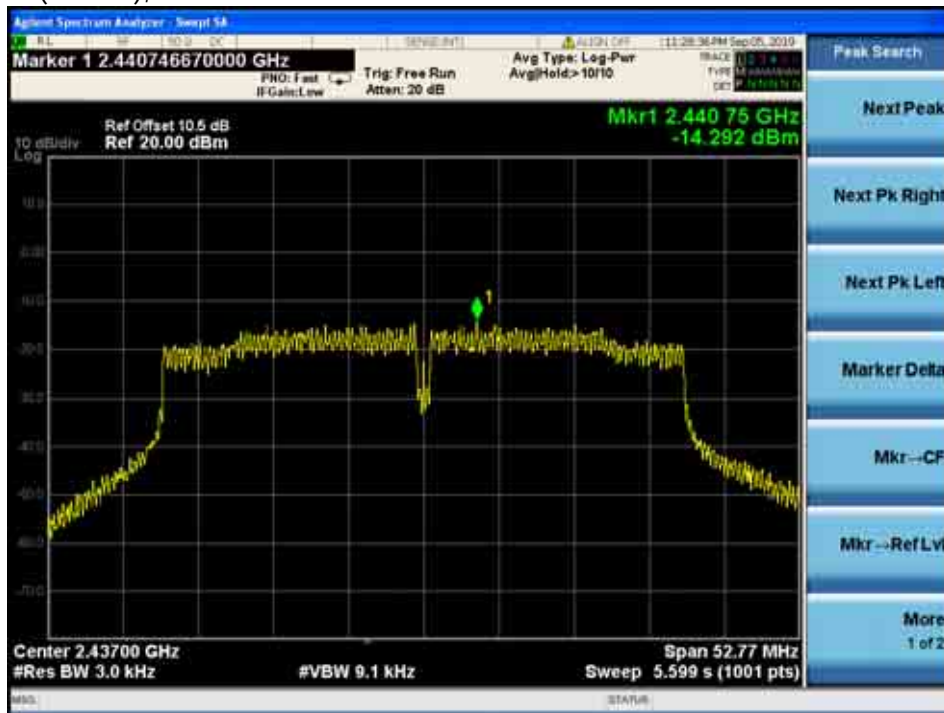

TEST REPORT

PLOTS OF POWER SPECTRAL DENSITY

Ant.1_802.11n (40MHz), Highest channel-1



Ant.1_802.11n (40MHz), Highest channel-2

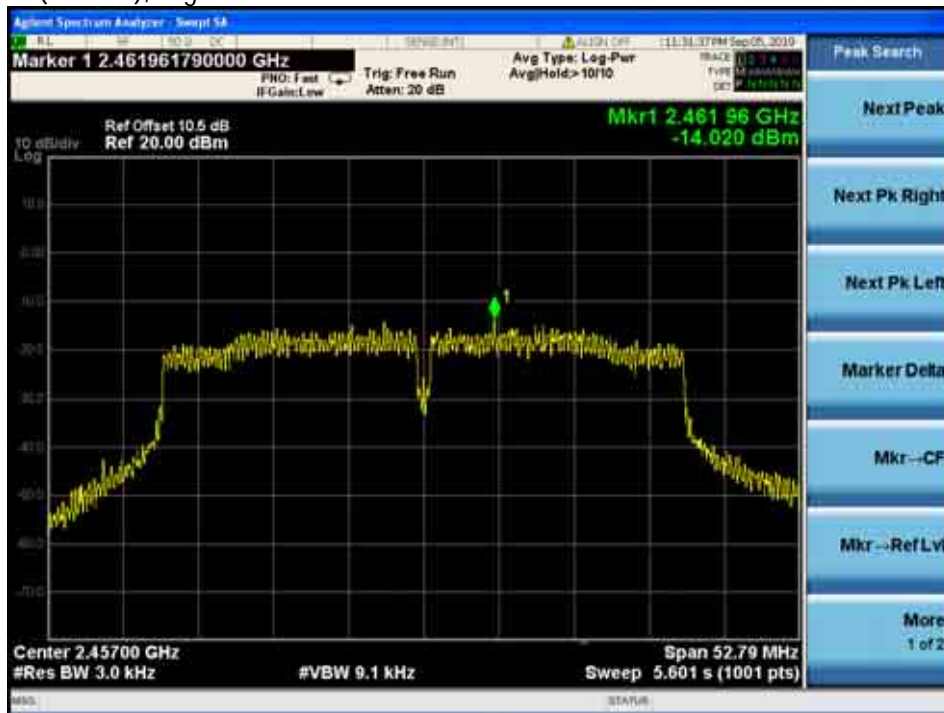

TEST REPORT

PLOTS OF POWER SPECTRAL DENSITY

Ant.1_802.11n (40MHz), Highest channel-3



TEST REPORT

PLOTS OF POWER SPECTRAL DENSITY

Ant.2_802.11b, Lowest channel



Ant.2_802.11b, Middle channel



TEST REPORT

PLOTS OF POWER SPECTRAL DENSITY

Ant.2_802.11b, Highest channel-1



Ant.2_802.11b, Highest channel-2



TEST REPORT

PLOTS OF POWER SPECTRAL DENSITY

Ant.2_802.11b, Highest channel-3



TEST REPORT

PLOTS OF POWER SPECTRAL DENSITY

Ant.2_802.11g, Lowest channel



Ant.2_802.11g, Middle channel



TEST REPORT

PLOTS OF POWER SPECTRAL DENSITY

Ant.2_802.11g, Highest channel-1



Ant.2_802.11g, Highest channel-2



TEST REPORT

PLOTS OF POWER SPECTRAL DENSITY

Ant.2_802.11g, Highest channel-3



TEST REPORT

PLOTS OF POWER SPECTRAL DENSITY

Ant.2_802.11n (20MHz), Lowest channel



Ant.2_802.11n (20MHz), Middle channel



TEST REPORT

PLOTS OF POWER SPECTRAL DENSITY

Ant.2_802.11n (20MHz), Highest channel-1



Ant.2_802.11n (20MHz), Highest channel-2



TEST REPORT

PLOTS OF POWER SPECTRAL DENSITY

Ant.2_802.11n (20MHz), Highest channel-3



TEST REPORT

PLOTS OF POWER SPECTRAL DENSITY

Ant.2_802.11n (40MHz), Lowest channel



Ant.2_802.11n (40MHz), Middle channel

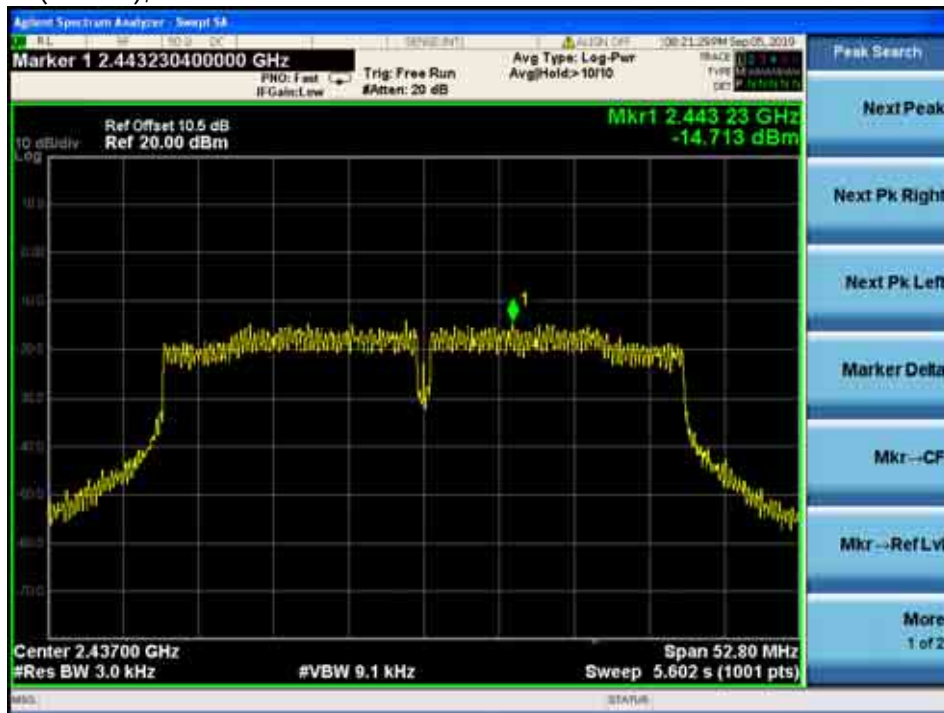

TEST REPORT

PLOTS OF POWER SPECTRAL DENSITY

Ant.2_802.11n (40MHz), Highest channel-1



Ant.2_802.11n (40MHz), Highest channel-2



TEST REPORT

PLOTS OF POWER SPECTRAL DENSITY

Ant.2_802.11n (40MHz), Highest channel-3



TEST REPORT

4.4 Out of Band Conducted Emissions

For 802.11b/g/n20/n40MHz, the maximum conducted (peak) output power was used to demonstrate compliance as described in 9.1. Then the display line (in red) shown in the following plots denotes the limit at 20dB below maximum measured in-band peak PSD level in 100 KHz bandwidth for 802.11b/g/n20/n40MHz.

The measurement procedures under No.KDB558074 D01 V05r02 were used.

Furthermore, delta measurement technique for measuring bandedge emissions was incorporated in the test of the edge at 2483.5MHz.

Limits:

All spurious emission and up to the tenth harmonic was measured and they were found to be at least for 802.11b,g,n20MHz, n40MHz below the maximum measured in-band peak PSD level.

TEST REPORT

PLOTS OF OUT OF BAND CONDUCTED EMISSIONS

Ant.1_802.11b, Lowest Channel, Plot A



Ant.1_802.11b, Lowest Channel, Plot B

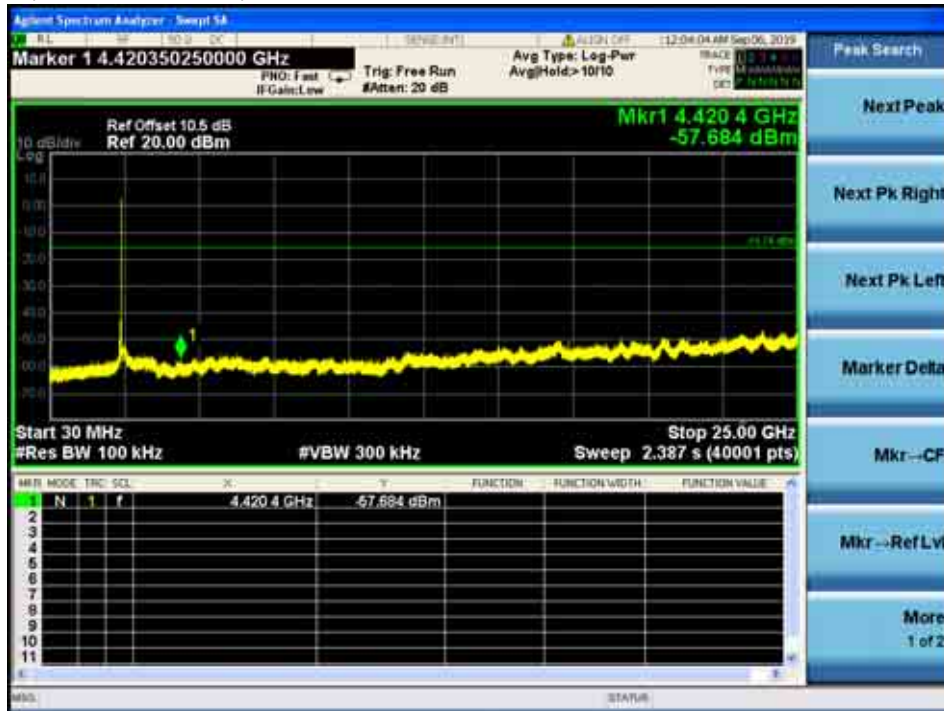

TEST REPORT

PLOTS OF OUT OF BAND CONDUCTED EMISSIONS

Ant.1_802.11b, Lowest Channel, Plot C



TEST REPORT

PLOTS OF OUT OF BAND CONDUCTED EMISSIONS

Ant.1_802.11b, Middle Channel, Plot A



Ant.1_802.11b, Middle Channel, Plot B

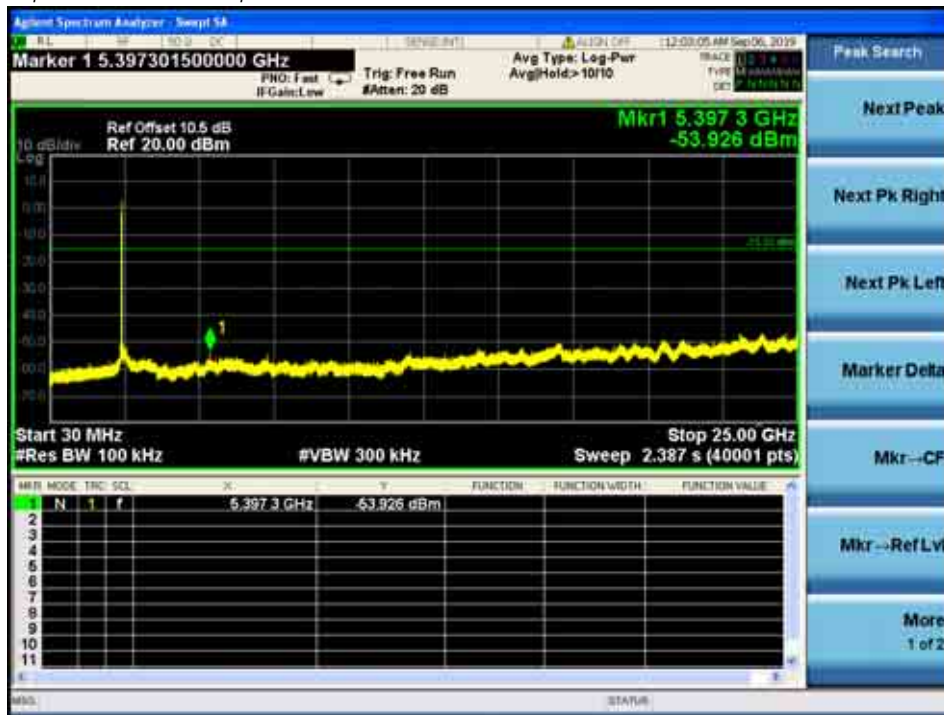

TEST REPORT

PLOTS OF OUT OF BAND CONDUCTED EMISSIONS

Ant.1_802.11b, Highest Channel-1, Plot A



Ant.1_802.11b, Highest Channel-1, Plot B

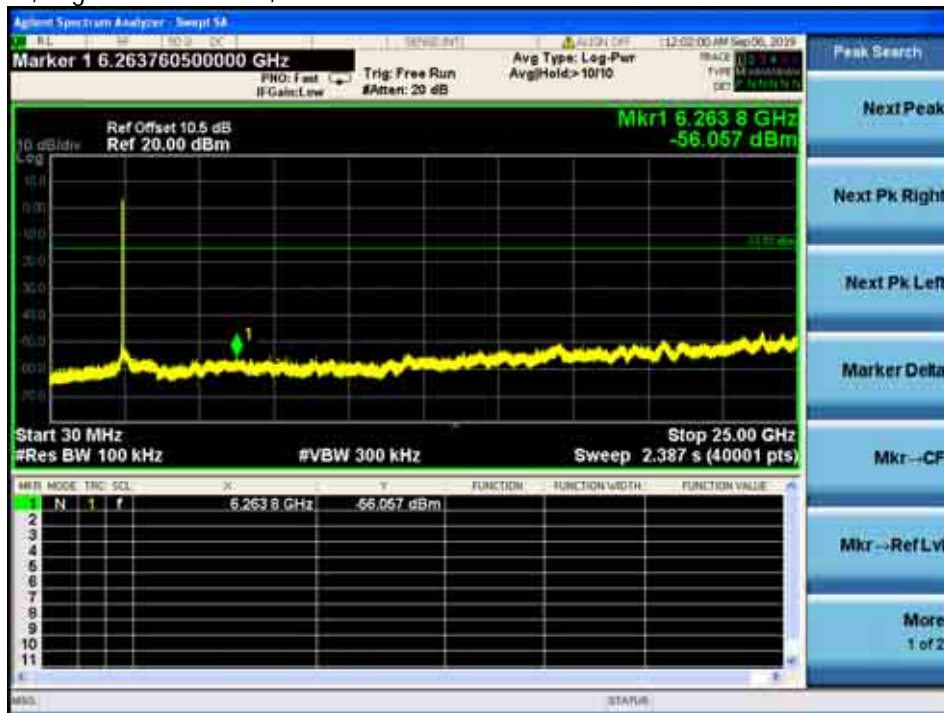

TEST REPORT

PLOTS OF OUT OF BAND CONDUCTED EMISSIONS

Ant.1_802.11b, Highest Channel-1, Plot C



TEST REPORT

PLOTS OF OUT OF BAND CONDUCTED EMISSIONS

Ant.1_802.11b, Highest Channel-2, Plot A



Ant.1_802.11b, Highest Channel-2, Plot B

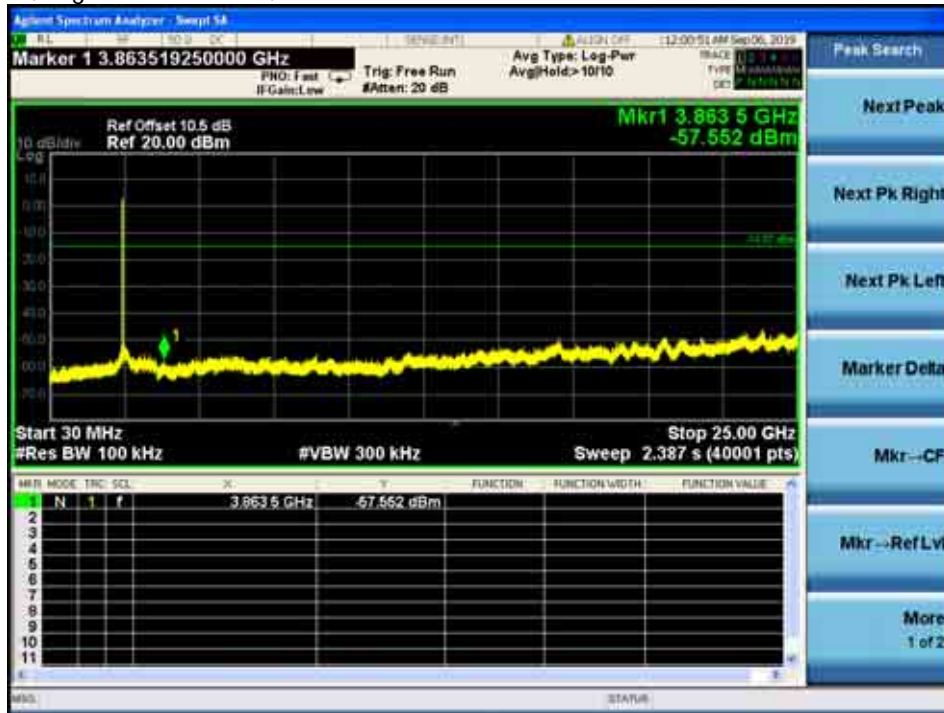

TEST REPORT

PLOTS OF OUT OF BAND CONDUCTED EMISSIONS

Ant.1_802.11b, Highest Channel-3, Plot A



Ant.1_802.11b, Highest Channel-3, Plot B

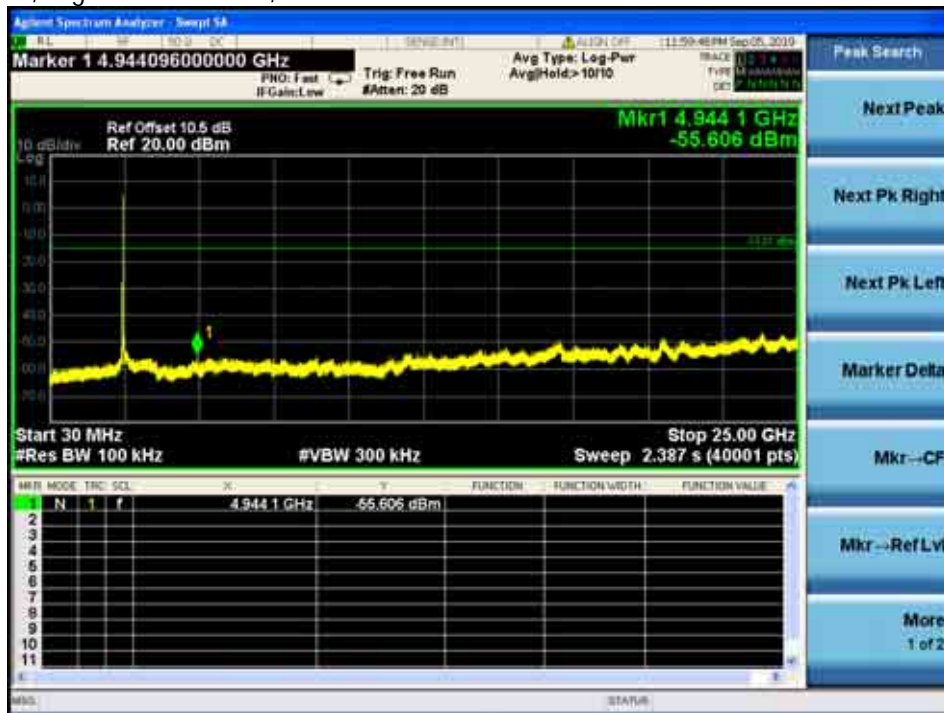

TEST REPORT

PLOTS OF OUT OF BAND CONDUCTED EMISSIONS

Ant.1_802.11b, Highest Channel-3, Plot C



TEST REPORT

PLOTS OF OUT OF BAND CONDUCTED EMISSIONS

Ant.1_802.11g, Lowest Channel, Plot A



Ant.1_802.11g, Lowest Channel, Plot B

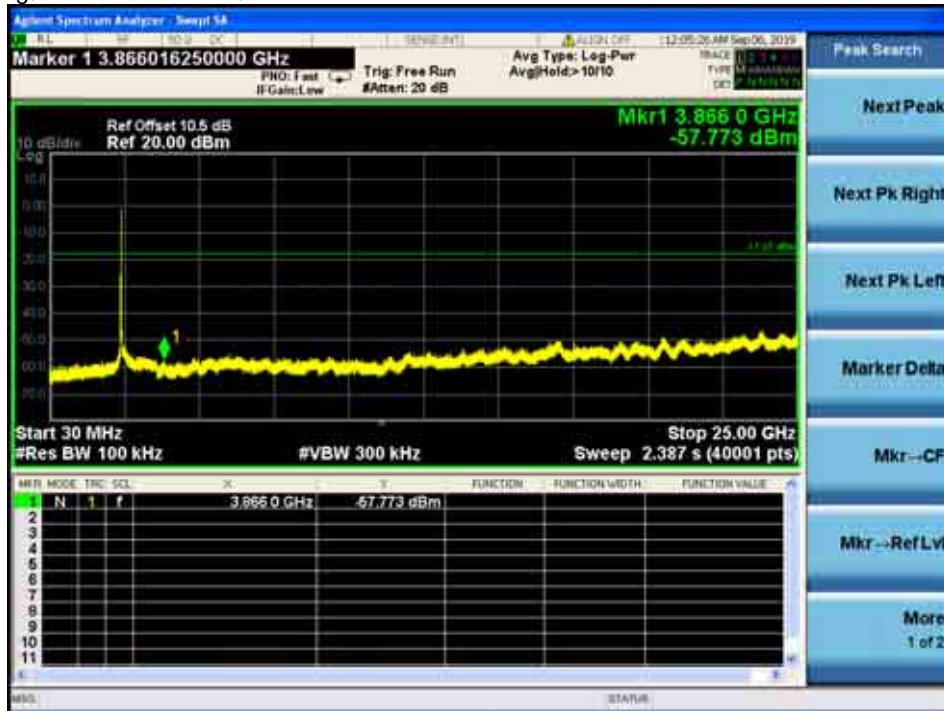

TEST REPORT

PLOTS OF OUT OF BAND CONDUCTED EMISSIONS

Ant.1_802.11g, Lowest Channel, Plot C



TEST REPORT

PLOTS OF OUT OF BAND CONDUCTED EMISSIONS

Ant.1_802.11g, Middle Channel, Plot A



Ant.1_802.11g, Middle Channel, Plot B

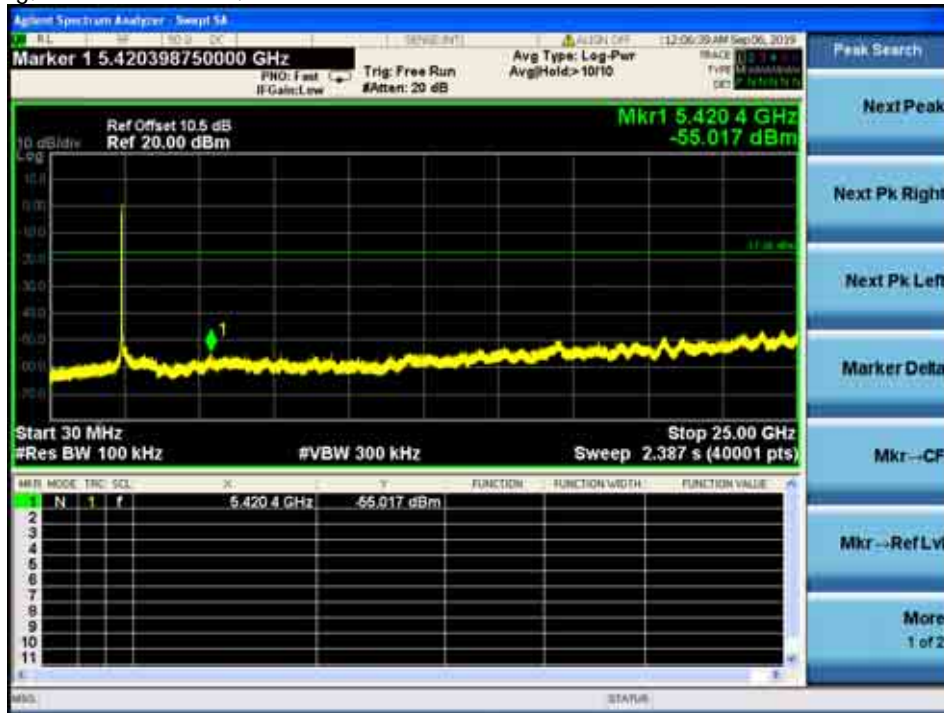

TEST REPORT

PLOTS OF OUT OF BAND CONDUCTED EMISSIONS

Ant.1_802.11g, Highest Channel-1, Plot A



Ant.1_802.11g, Highest Channel-1, Plot B

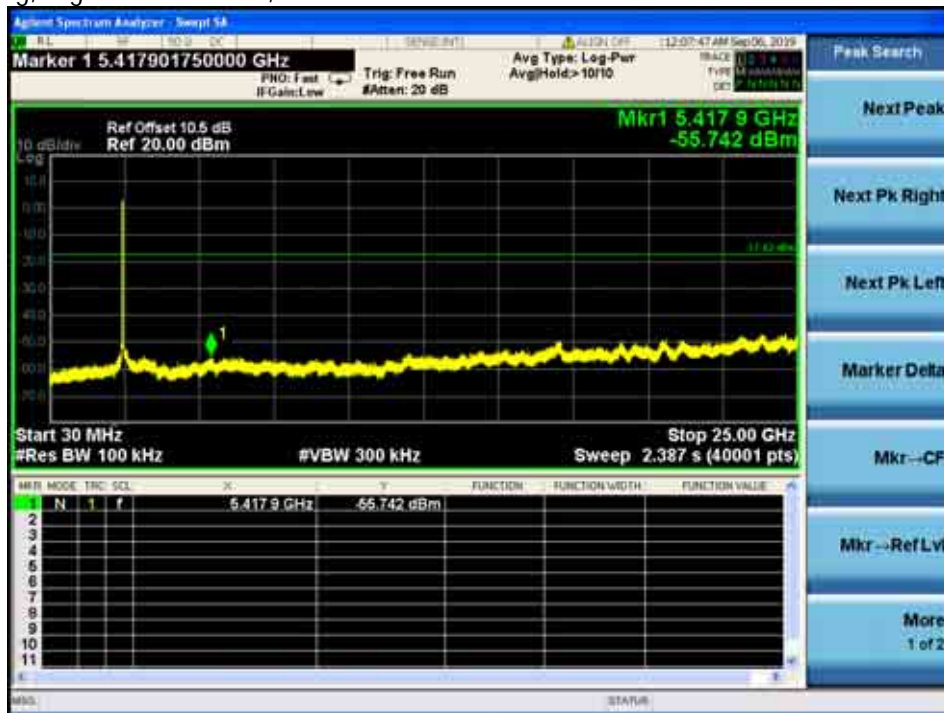

TEST REPORT

PLOTS OF OUT OF BAND CONDUCTED EMISSIONS

Ant.1_802.11g, Highest Channel-1, Plot C



TEST REPORT

PLOTS OF OUT OF BAND CONDUCTED EMISSIONS

Ant.1_802.11g, Highest Channel-2, Plot A



Ant.1_802.11g, Highest Channel-2, Plot B

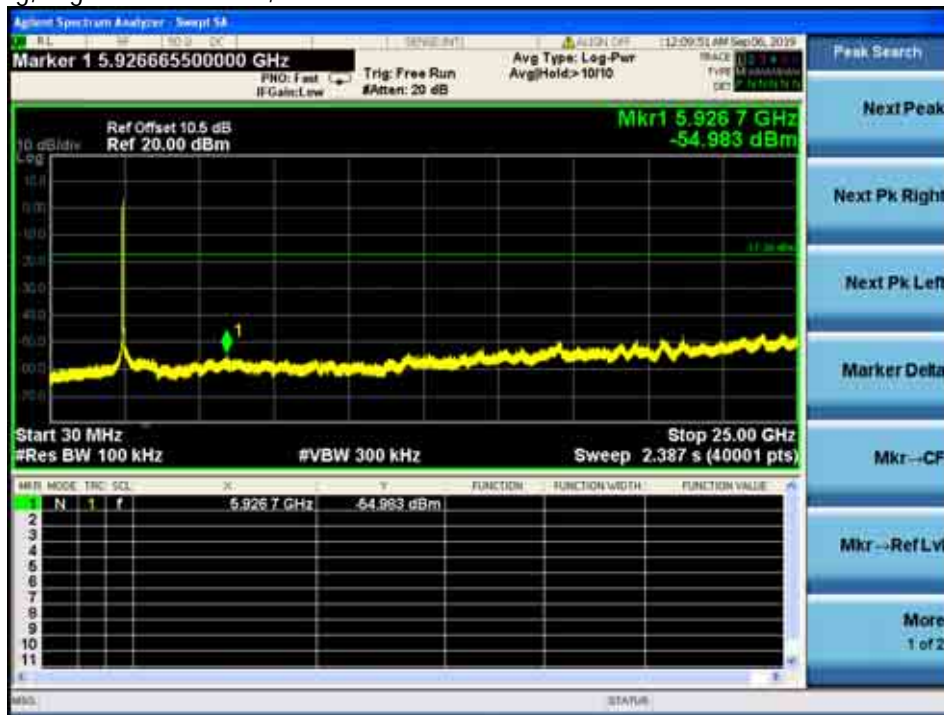

TEST REPORT

PLOTS OF OUT OF BAND CONDUCTED EMISSIONS

Ant.1_802.11g, Highest Channel-3, Plot A



Ant.1_802.11g, Highest Channel-3, Plot B

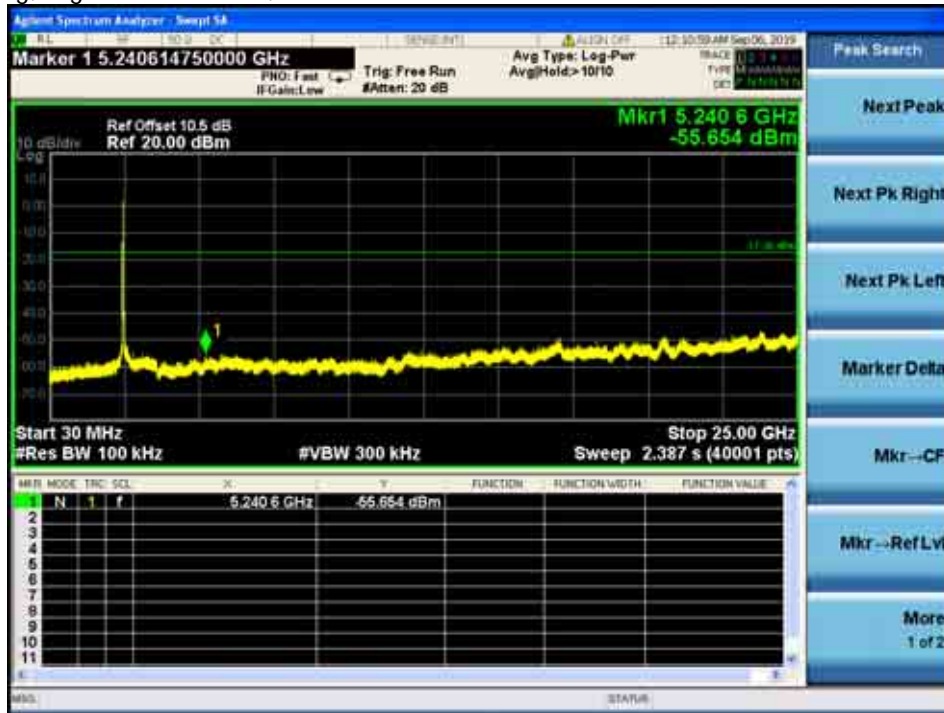

TEST REPORT

PLOTS OF OUT OF BAND CONDUCTED EMISSIONS

Ant.1_802.11g, Highest Channel-3, Plot C



TEST REPORT

PLOTS OF OUT OF BAND CONDUCTED EMISSIONS

Ant.1_802.11n (20MHz), Lowest Channel, Plot A



Ant.1_802.11n (20MHz), Lowest Channel, Plot B

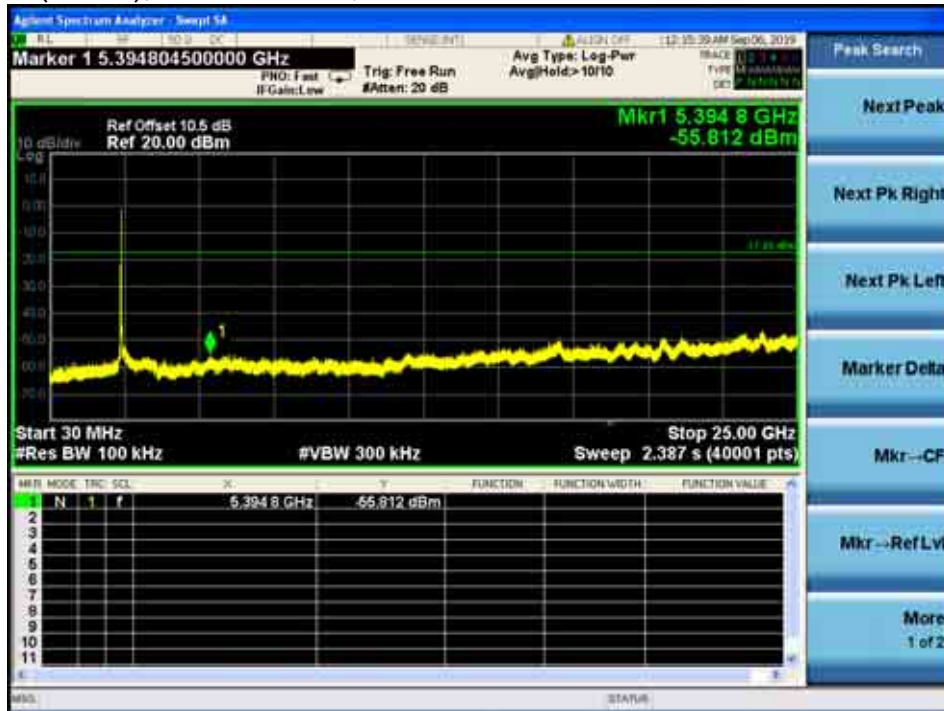

TEST REPORT

PLOTS OF OUT OF BAND CONDUCTED EMISSIONS

Ant.1_802.11n (20MHz), Lowest Channel, Plot C



TEST REPORT

PLOTS OF OUT OF BAND CONDUCTED EMISSIONS

Ant.1_802.11n (20MHz), Middle Channel, Plot A



Ant.1_802.11n (20MHz), Middle Channel, Plot B

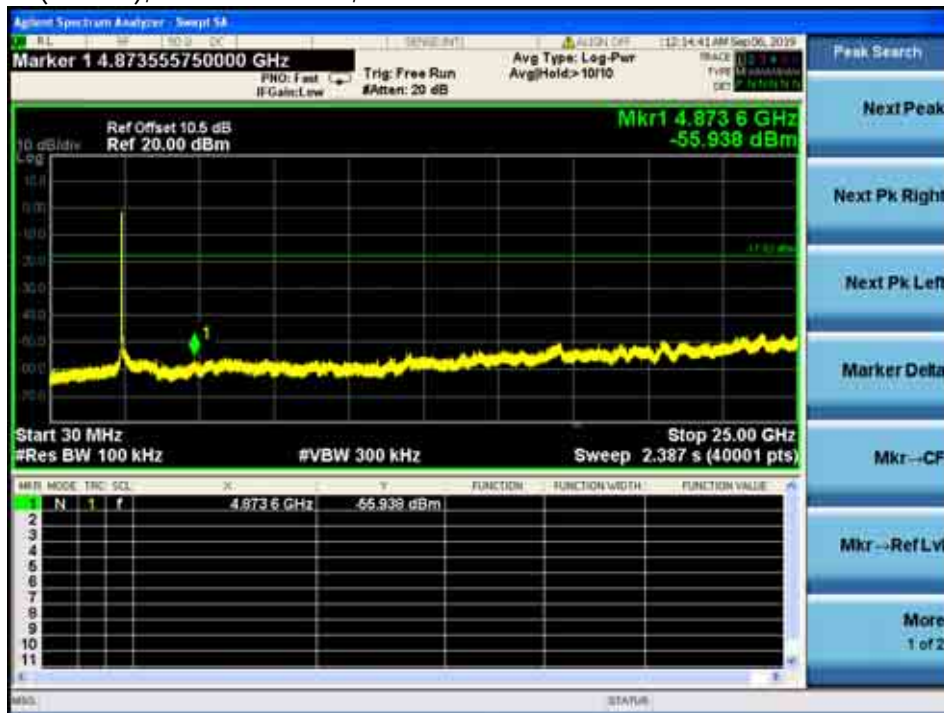

TEST REPORT

PLOTS OF OUT OF BAND CONDUCTED EMISSIONS

Ant.1_802.11n (20MHz), Highest Channel-1, Plot A



Ant.1_802.11n (20MHz), Highest Channel-1, Plot B

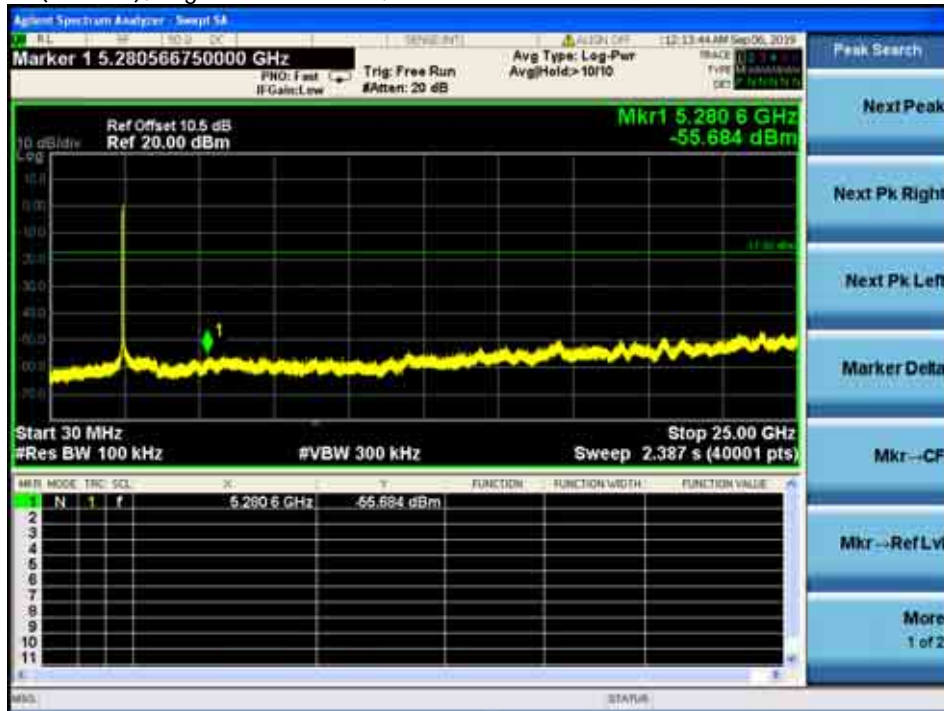

TEST REPORT

PLOTS OF OUT OF BAND CONDUCTED EMISSIONS

Ant.1_802.11n (20MHz), Highest Channel-1, Plot C



TEST REPORT

PLOTS OF OUT OF BAND CONDUCTED EMISSIONS

Ant.1_802.11n (20MHz), Highest Channel-2, Plot A



Ant.1_802.11n (20MHz), Highest Channel-2, Plot B

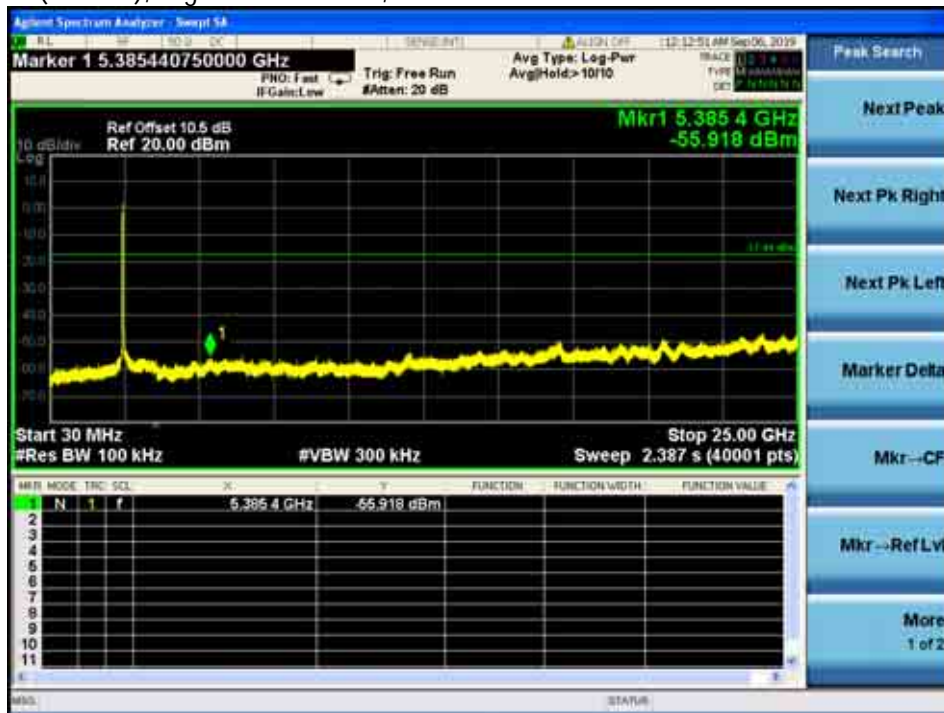

TEST REPORT

PLOTS OF OUT OF BAND CONDUCTED EMISSIONS

Ant.1_802.11n (20MHz), Highest Channel-3, Plot A



Ant.1_802.11n (20MHz), Highest Channel-3, Plot B

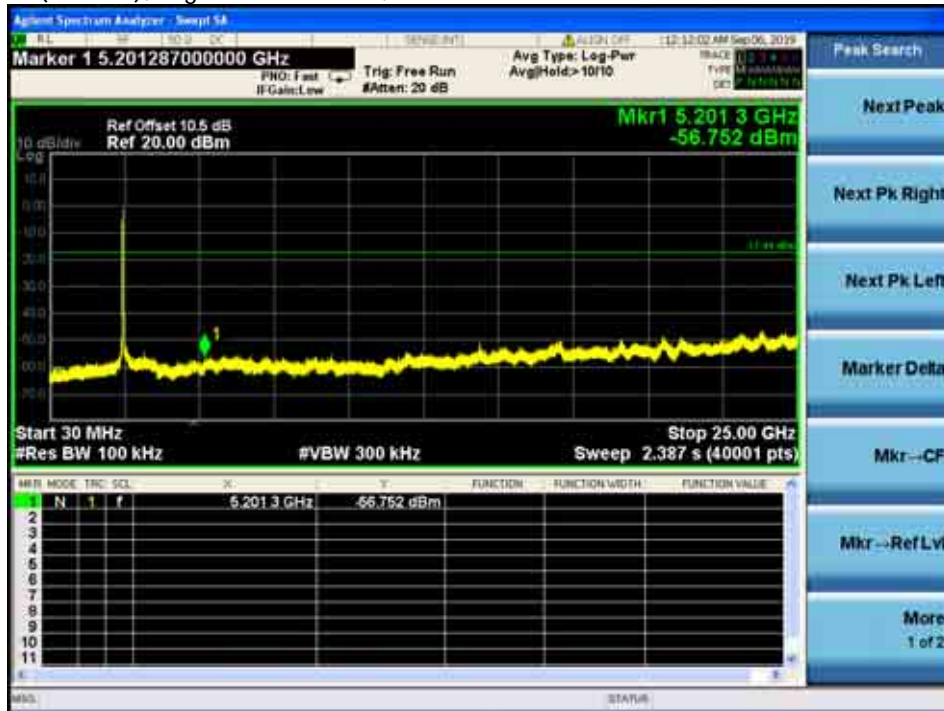

TEST REPORT

PLOTS OF OUT OF BAND CONDUCTED EMISSIONS

Ant.1_802.11n (20MHz), Highest Channel-3, Plot C



TEST REPORT

PLOTS OF OUT OF BAND CONDUCTED EMISSIONS

Ant.1_802.11n (40MHz), Lowest Channel, Plot A



Ant.1_802.11n (40MHz), Lowest Channel, Plot B

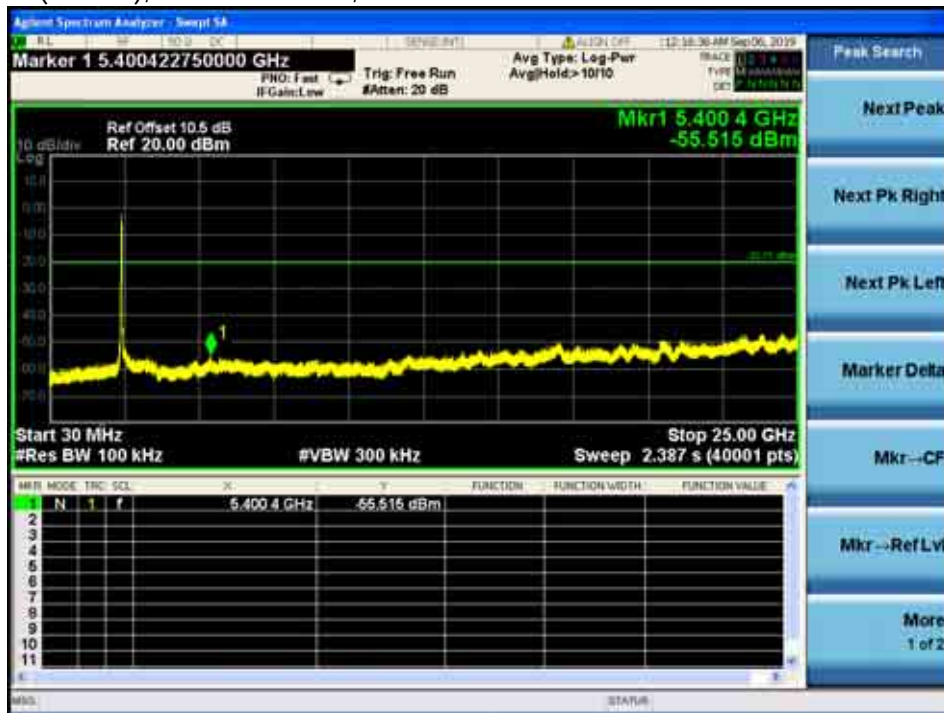

TEST REPORT

PLOTS OF OUT OF BAND CONDUCTED EMISSIONS

Ant.1_802.11n (40MHz), Lowest Channel, Plot C



TEST REPORT

PLOTS OF OUT OF BAND CONDUCTED EMISSIONS

Ant.1_802.11n (40MHz), Middle Channel, Plot A



Ant.1_802.11n (40MHz), Middle Channel, Plot B

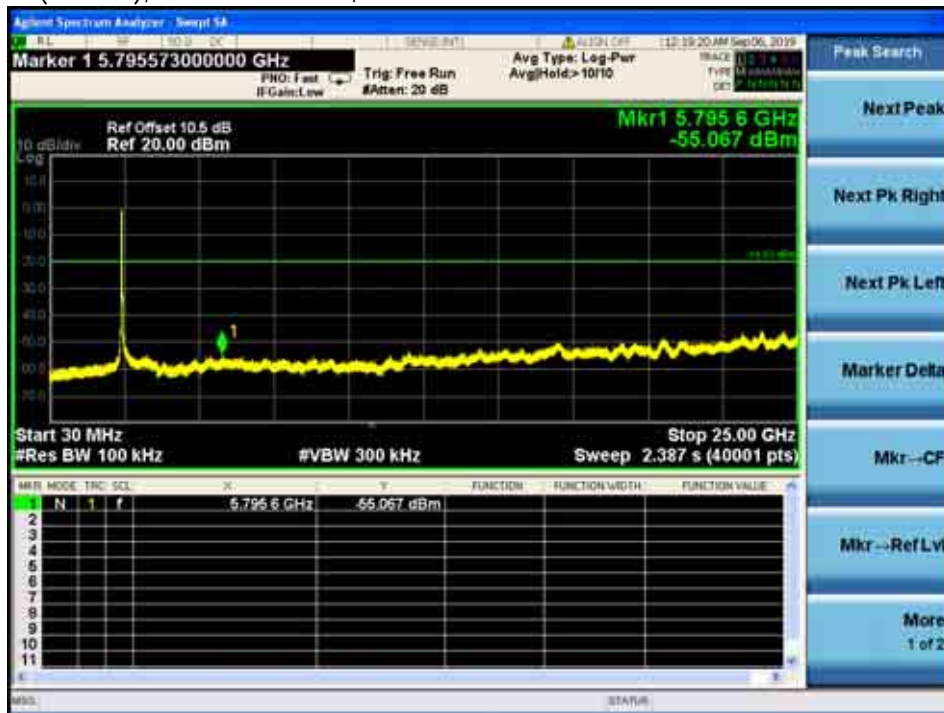

TEST REPORT

PLOTS OF OUT OF BAND CONDUCTED EMISSIONS

Ant.1_802.11n (40MHz), Highest Channel-1, Plot A



Ant.1_802.11n (40MHz), Highest Channel-1, Plot B

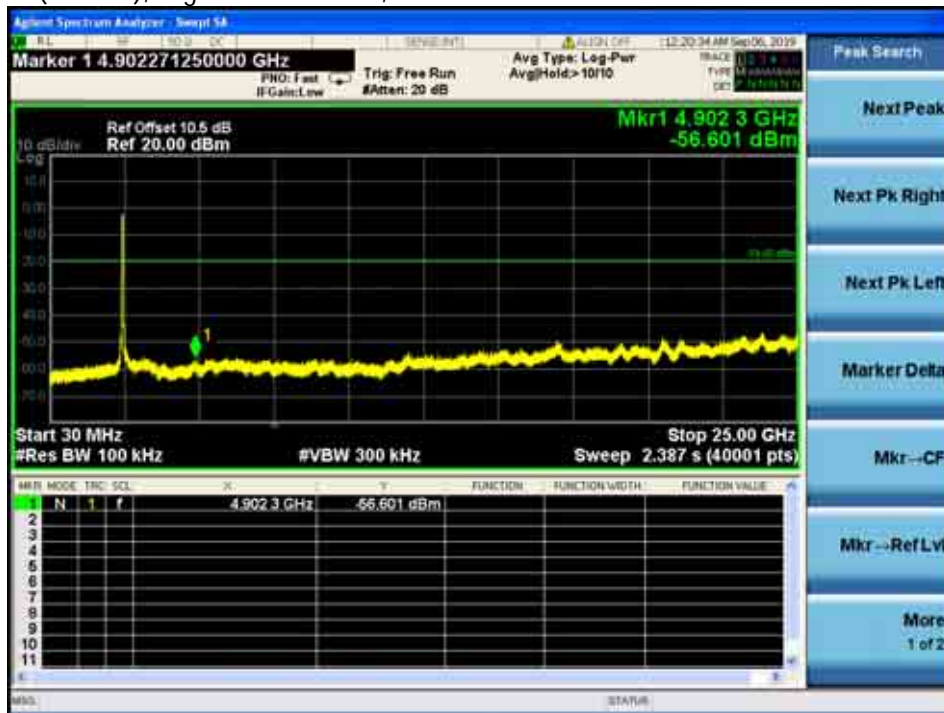

TEST REPORT

PLOTS OF OUT OF BAND CONDUCTED EMISSIONS

Ant.1_802.11n (40MHz), Highest Channel-1, Plot C



TEST REPORT

PLOTS OF OUT OF BAND CONDUCTED EMISSIONS

Ant.1_802.11n (40MHz), Highest Channel-2, Plot A



Ant.1_802.11n (40MHz), Highest Channel-2, Plot B

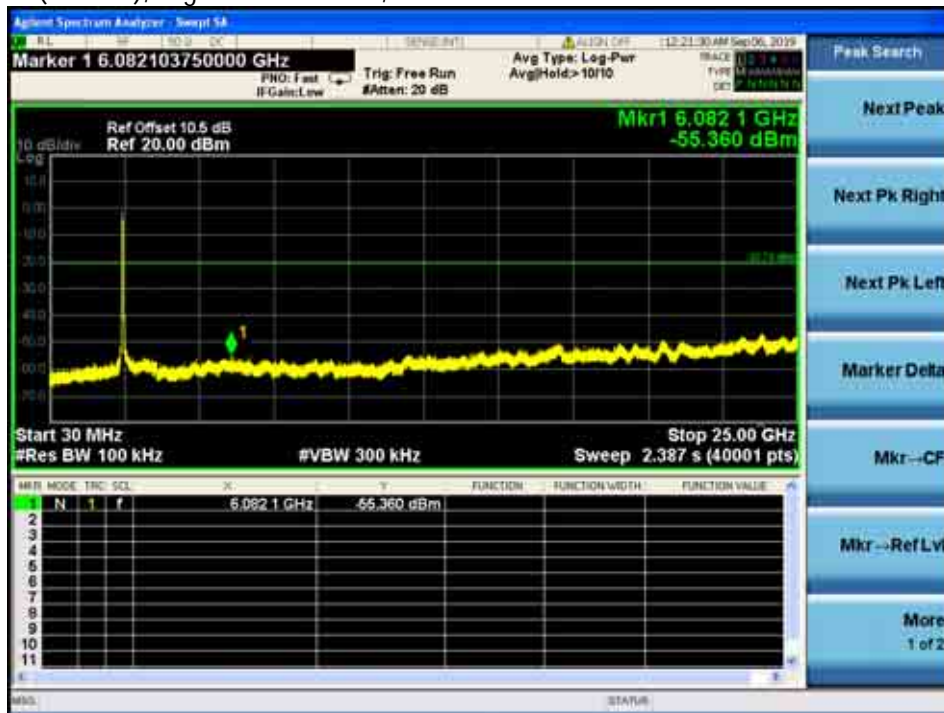

TEST REPORT

PLOTS OF OUT OF BAND CONDUCTED EMISSIONS

Ant.1_802.11n (40MHz), Highest Channel-3, Plot A



Ant.1_802.11n (40MHz), Highest Channel-3, Plot B

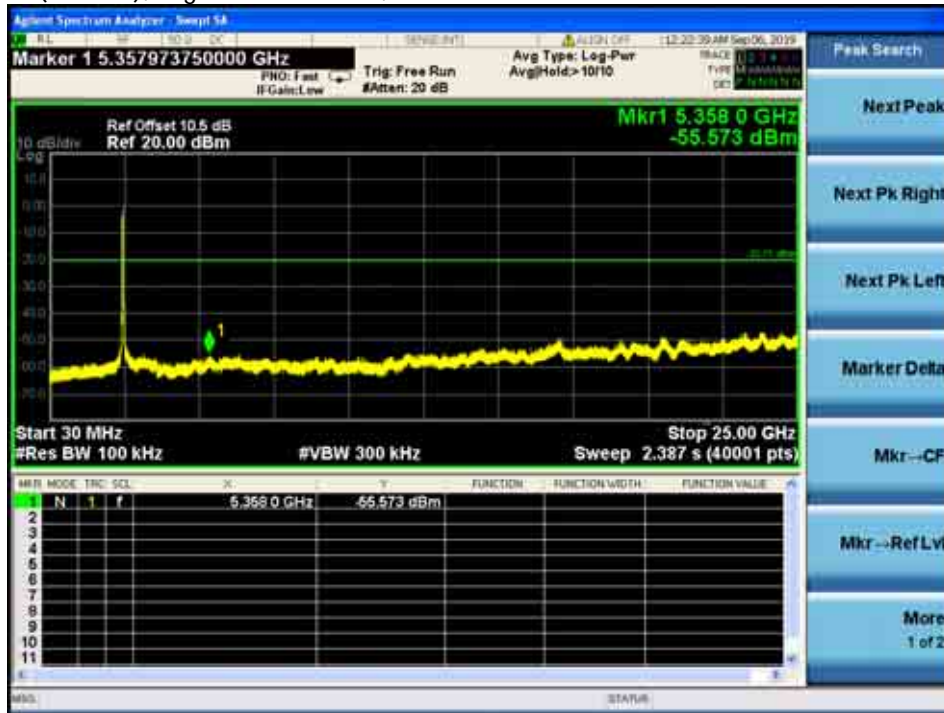

TEST REPORT

PLOTS OF OUT OF BAND CONDUCTED EMISSIONS

Ant.1_802.11n (40MHz), Highest Channel-3, Plot C



TEST REPORT

PLOTS OF OUT OF BAND CONDUCTED EMISSIONS

Ant.2_802.11b, Lowest Channel, Plot A



Ant.2_802.11b, Lowest Channel, Plot B

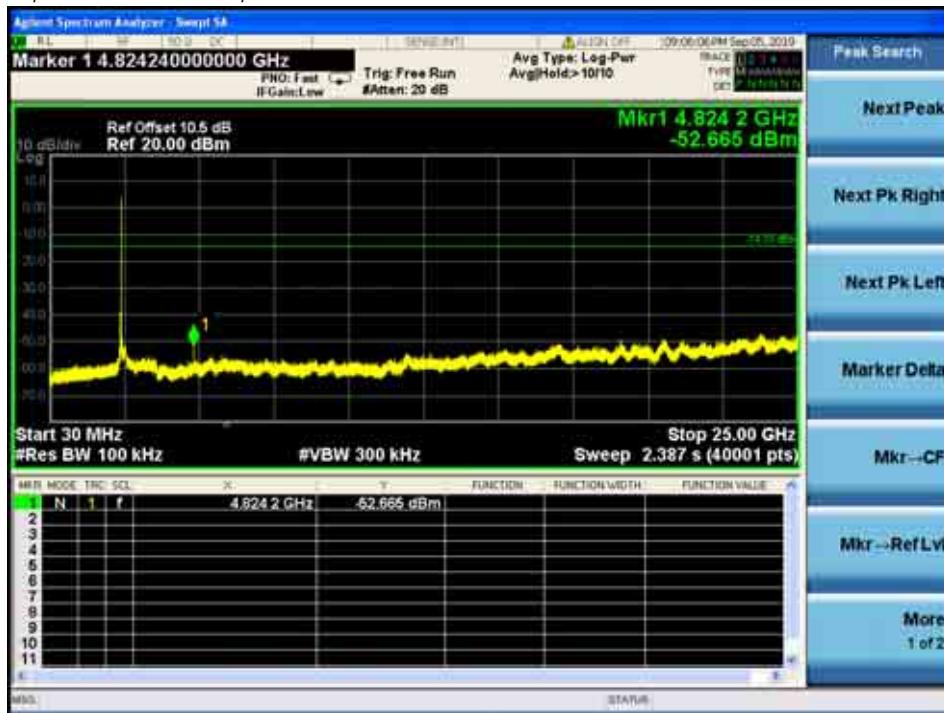

TEST REPORT

PLOTS OF OUT OF BAND CONDUCTED EMISSIONS

Ant.2_802.11b, Lowest Channel, Plot C



TEST REPORT

PLOTS OF OUT OF BAND CONDUCTED EMISSIONS

Ant.2_802.11b, Middle Channel, Plot A



Ant.2_802.11b, Middle Channel, Plot B

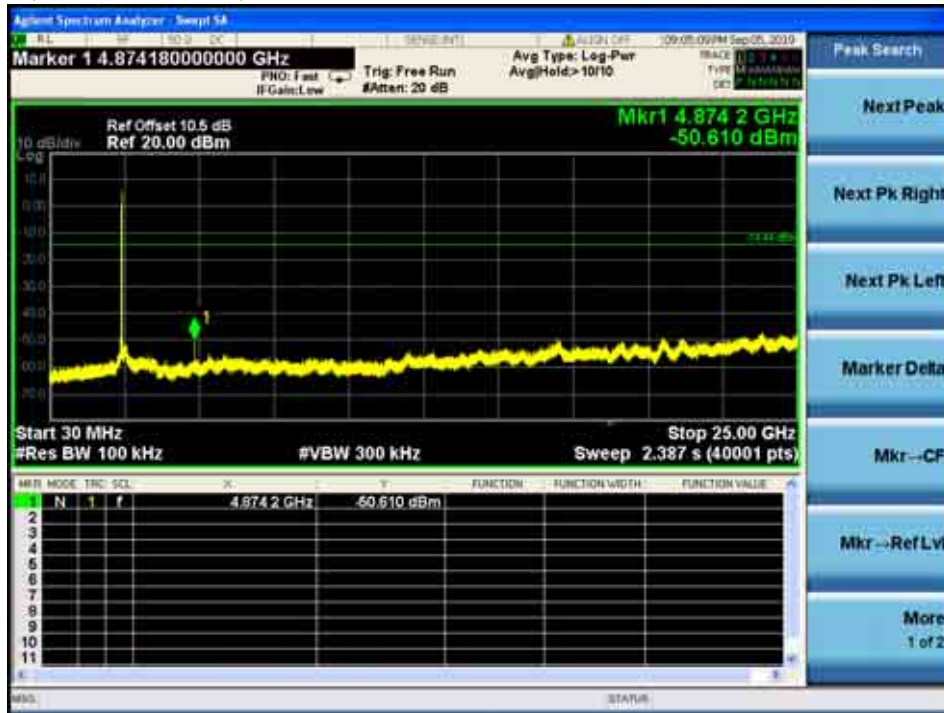

TEST REPORT

PLOTS OF OUT OF BAND CONDUCTED EMISSIONS

Ant.2_802.11b, Highest Channel-1, Plot A



Ant.2_802.11b, Highest Channel-1, Plot B

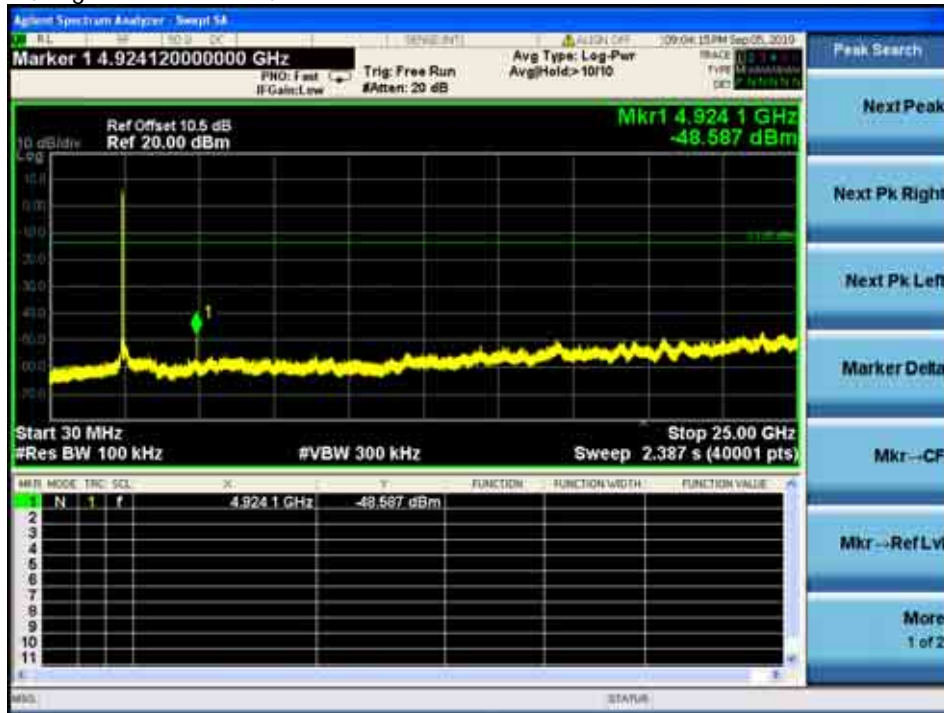

TEST REPORT

PLOTS OF OUT OF BAND CONDUCTED EMISSIONS

Ant.2_802.11b, Highest Channel-1, Plot C



TEST REPORT

PLOTS OF OUT OF BAND CONDUCTED EMISSIONS

Ant.2_802.11b, Highest Channel-2, Plot A



Ant.2_802.11b, Highest Channel-2, Plot B

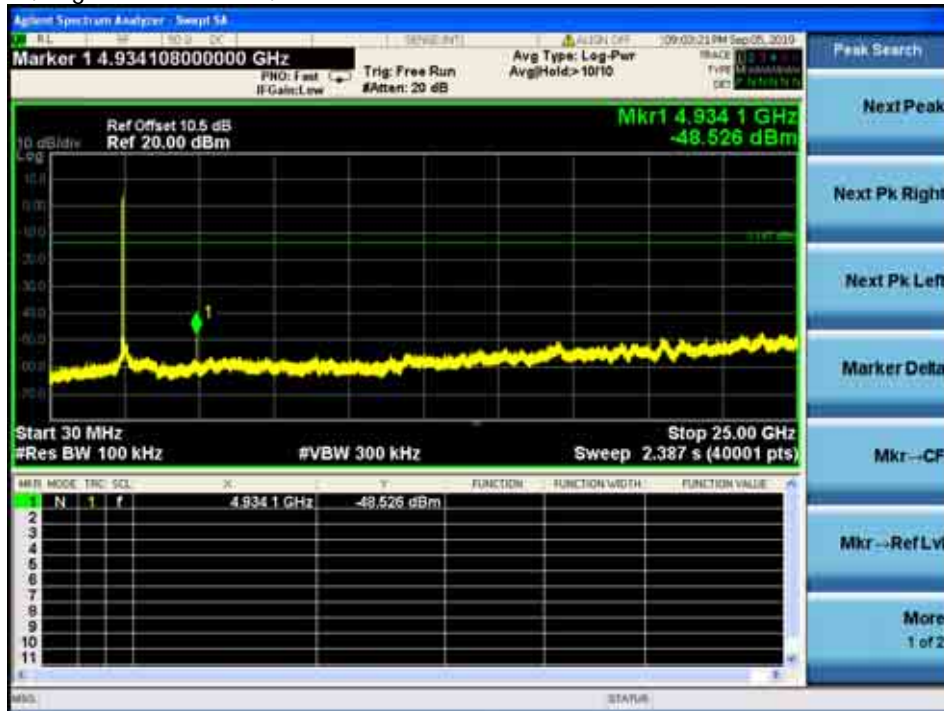

TEST REPORT

PLOTS OF OUT OF BAND CONDUCTED EMISSIONS

Ant.2_802.11b, Highest Channel-3, Plot A



Ant.2_802.11b, Highest Channel-3, Plot B

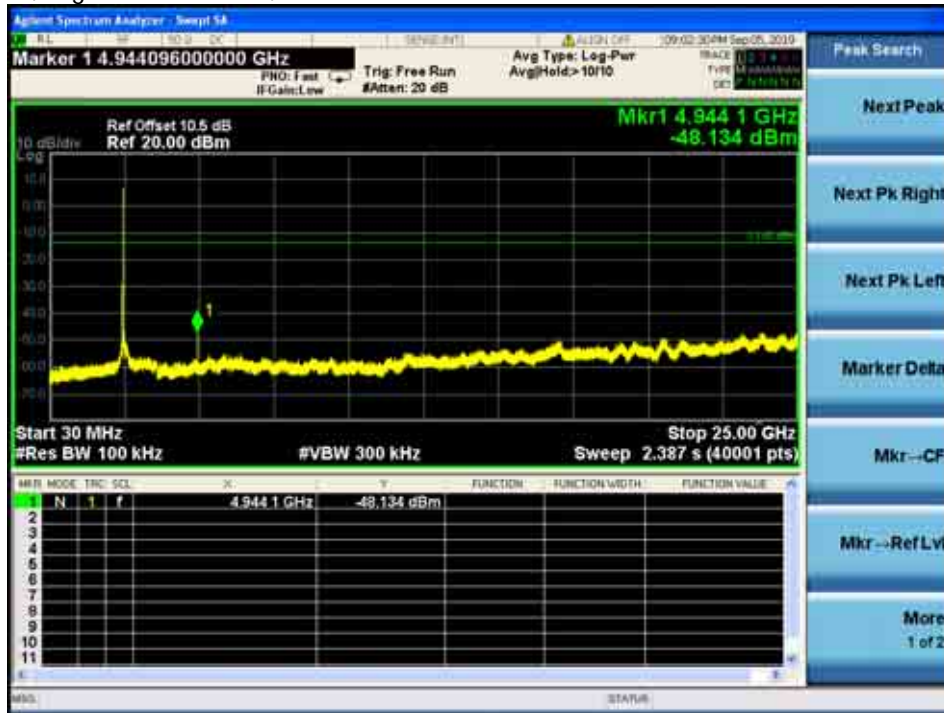

TEST REPORT

PLOTS OF OUT OF BAND CONDUCTED EMISSIONS

Ant.2_802.11b, Highest Channel-3, Plot C



TEST REPORT

PLOTS OF OUT OF BAND CONDUCTED EMISSIONS

Ant.2_802.11g, Lowest Channel, Plot A



Ant.2_802.11g, Lowest Channel, Plot B

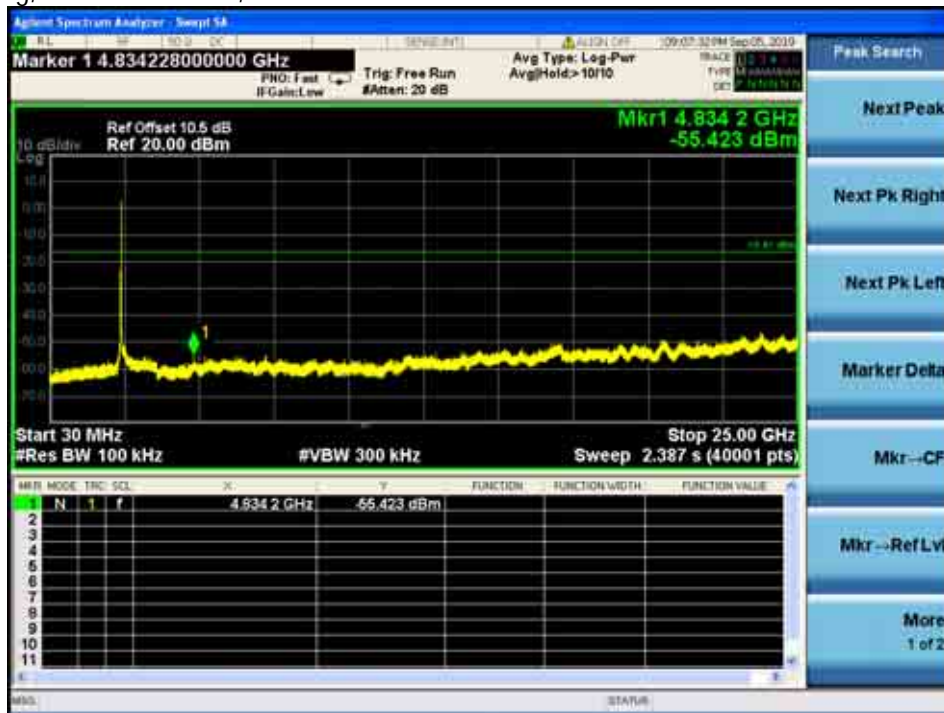

TEST REPORT

PLOTS OF OUT OF BAND CONDUCTED EMISSIONS

Ant.2_802.11g, Lowest Channel, Plot C



TEST REPORT

PLOTS OF OUT OF BAND CONDUCTED EMISSIONS

Ant.2_802.11g, Middle Channel, Plot A



Ant.2_802.11g, Middle Channel, Plot B

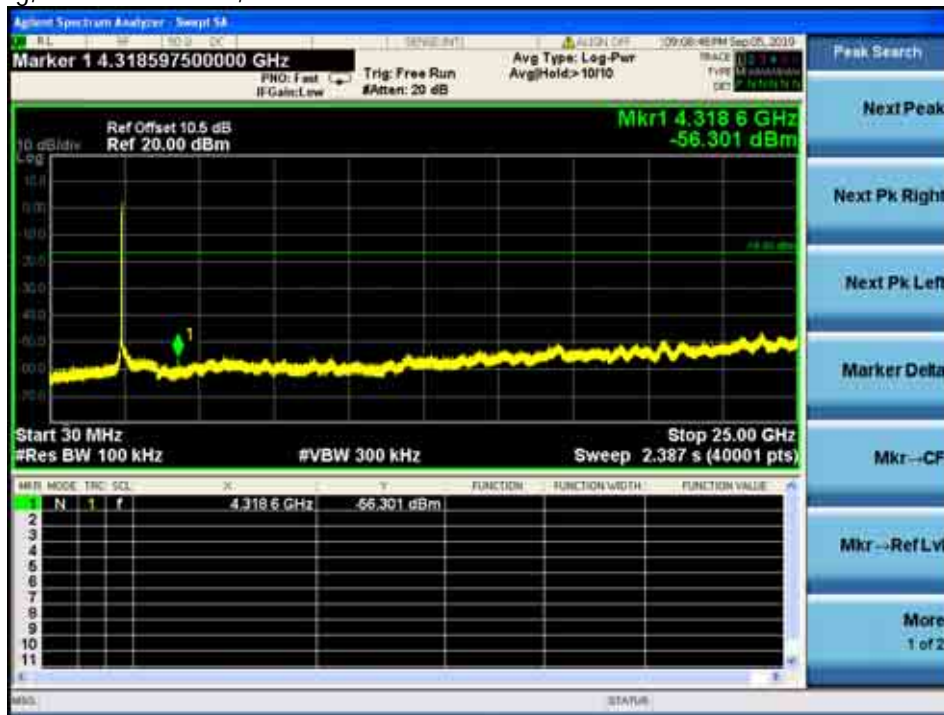

TEST REPORT

PLOTS OF OUT OF BAND CONDUCTED EMISSIONS

Ant.2_802.11g, Highest Channel-1, Plot A



Ant.2_802.11g, Highest Channel-1, Plot B

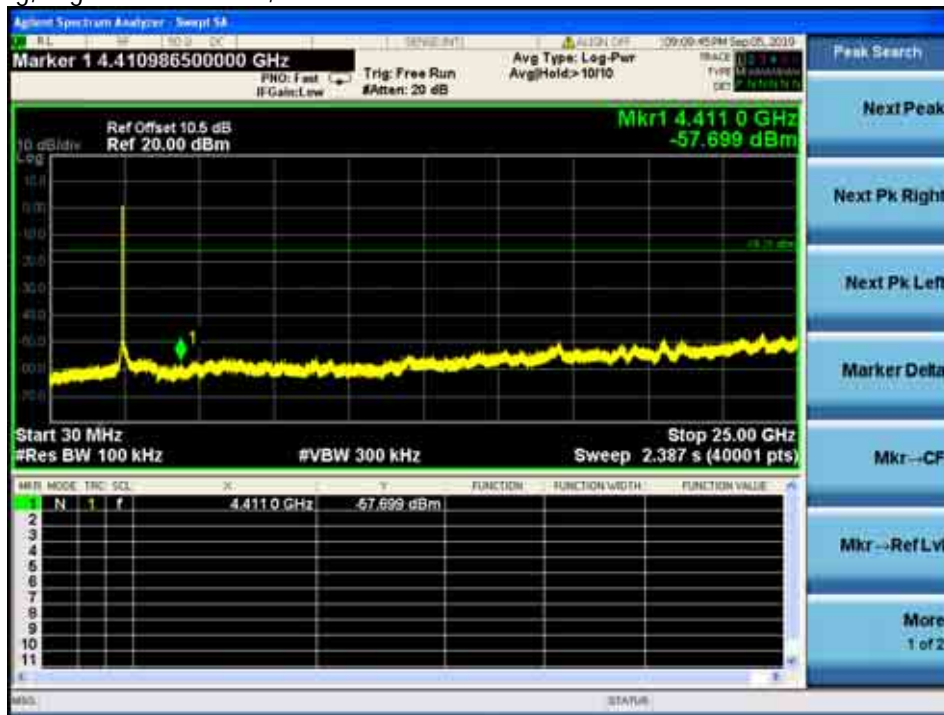

TEST REPORT

PLOTS OF OUT OF BAND CONDUCTED EMISSIONS

Ant.2_802.11g, Highest Channel-1, Plot C



TEST REPORT

PLOTS OF OUT OF BAND CONDUCTED EMISSIONS

Ant.2_802.11g, Highest Channel-2, Plot A



Ant.2_802.11g, Highest Channel-2, Plot B

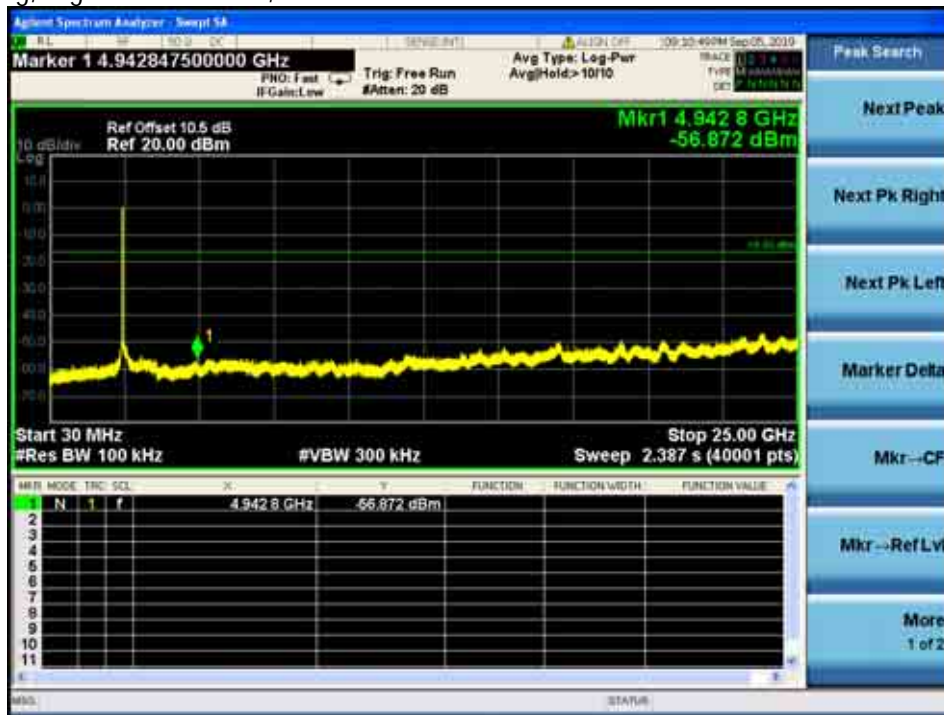

TEST REPORT

PLOTS OF OUT OF BAND CONDUCTED EMISSIONS

Ant.2_802.11g, Highest Channel-3, Plot A



Ant.2_802.11g, Highest Channel-3, Plot B

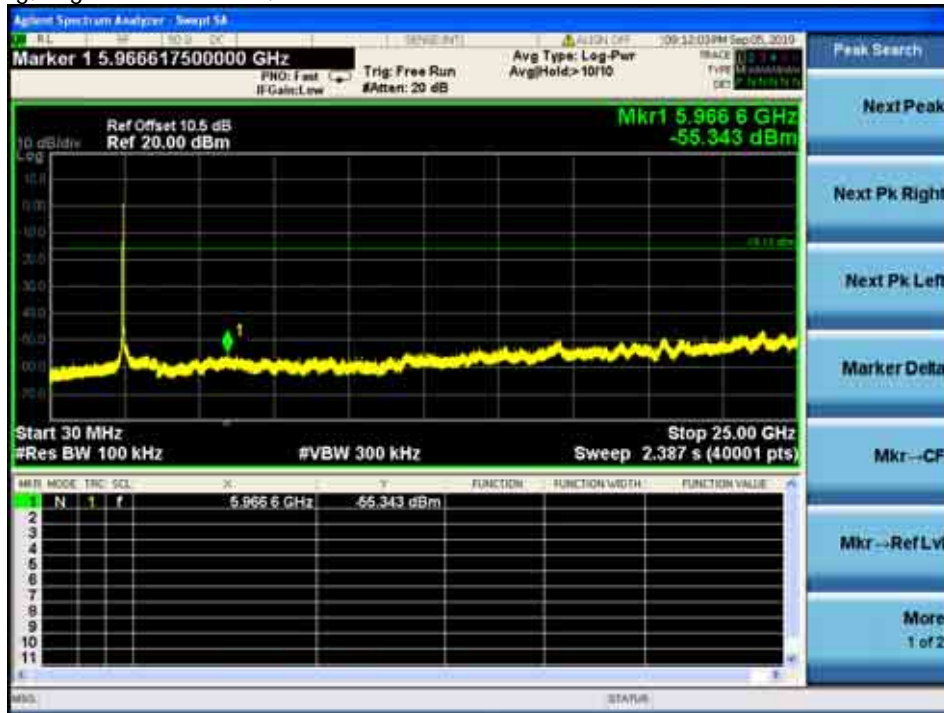

TEST REPORT

PLOTS OF OUT OF BAND CONDUCTED EMISSIONS

Ant.2_802.11g, Highest Channel-3, Plot C



TEST REPORT

PLOTS OF OUT OF BAND CONDUCTED EMISSIONS

Ant.2_802.11n (20MHz), Lowest Channel, Plot A



Ant.2_802.11n (20MHz), Lowest Channel, Plot B

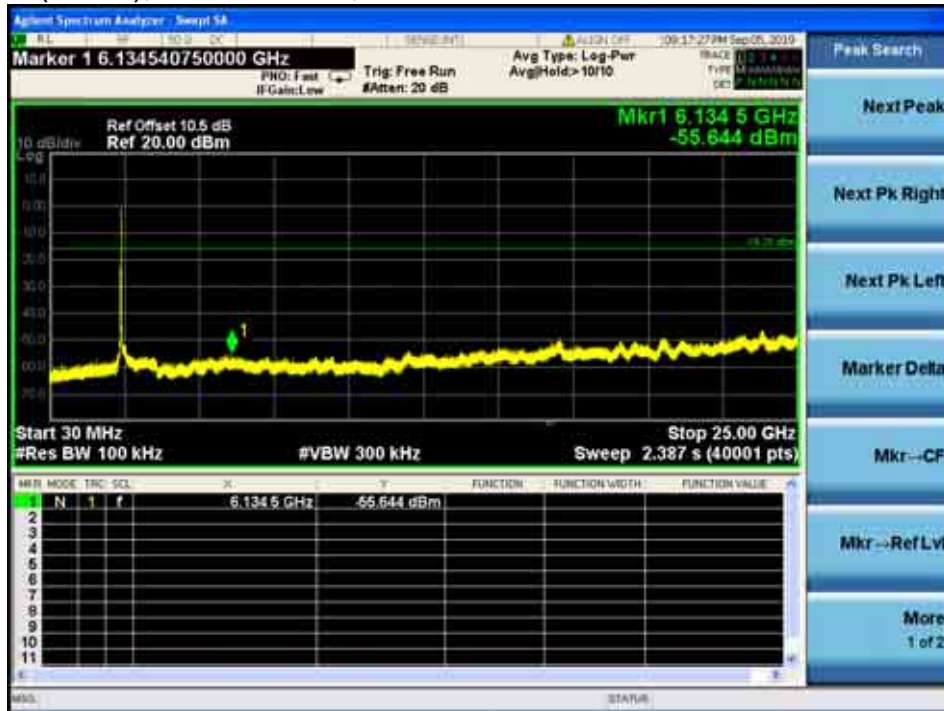

TEST REPORT

PLOTS OF OUT OF BAND CONDUCTED EMISSIONS

Ant.2_802.11n (20MHz), Lowest Channel, Plot C



TEST REPORT

PLOTS OF OUT OF BAND CONDUCTED EMISSIONS

Ant.2_802.11n (20MHz), Middle Channel, Plot A



Ant.2_802.11n (20MHz), Middle Channel, Plot B

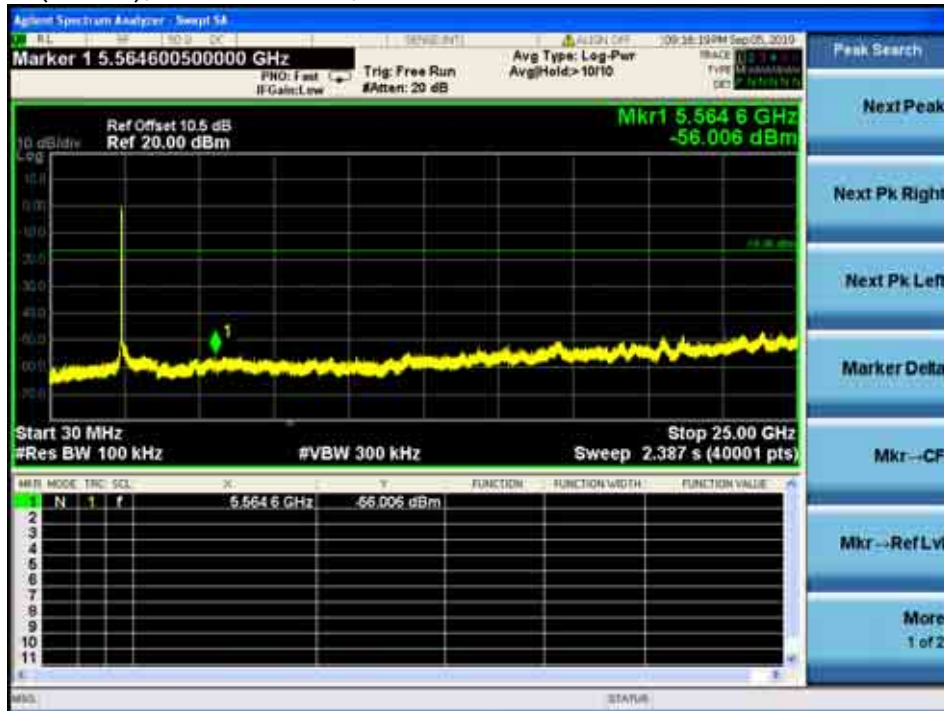

TEST REPORT

PLOTS OF OUT OF BAND CONDUCTED EMISSIONS

Ant.2_802.11n (20MHz), Highest Channel-1, Plot A



Ant.2_802.11n (20MHz), Highest Channel-1, Plot B

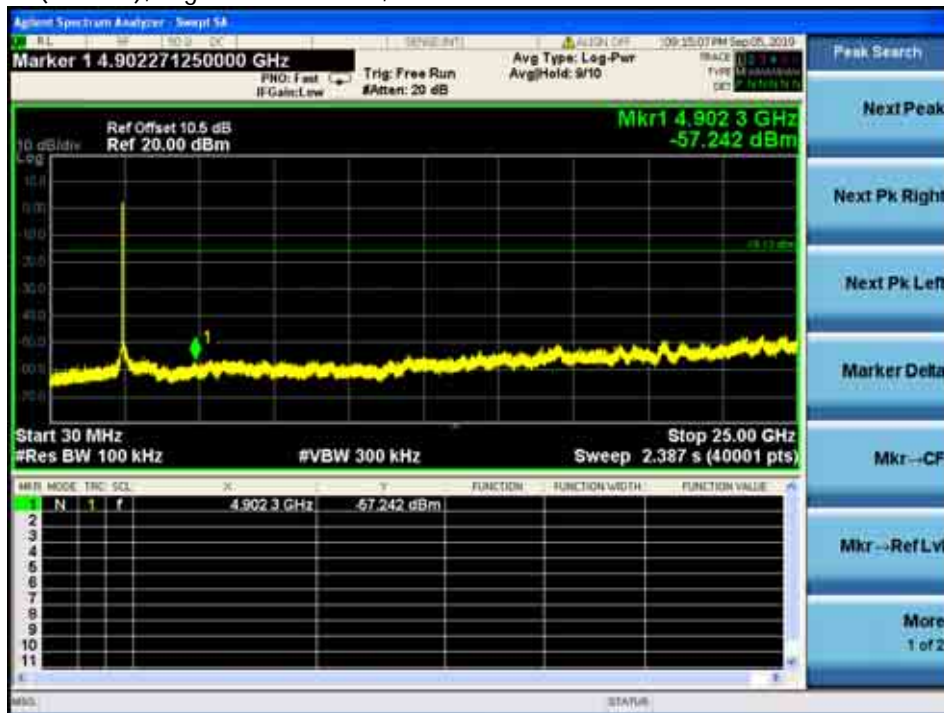

TEST REPORT

PLOTS OF OUT OF BAND CONDUCTED EMISSIONS

Ant.2_802.11n (20MHz), Highest Channel-1, Plot C



TEST REPORT

PLOTS OF OUT OF BAND CONDUCTED EMISSIONS

Ant.2_802.11n (20MHz), Highest Channel-2, Plot A



Ant.2_802.11n (20MHz), Highest Channel-2, Plot B

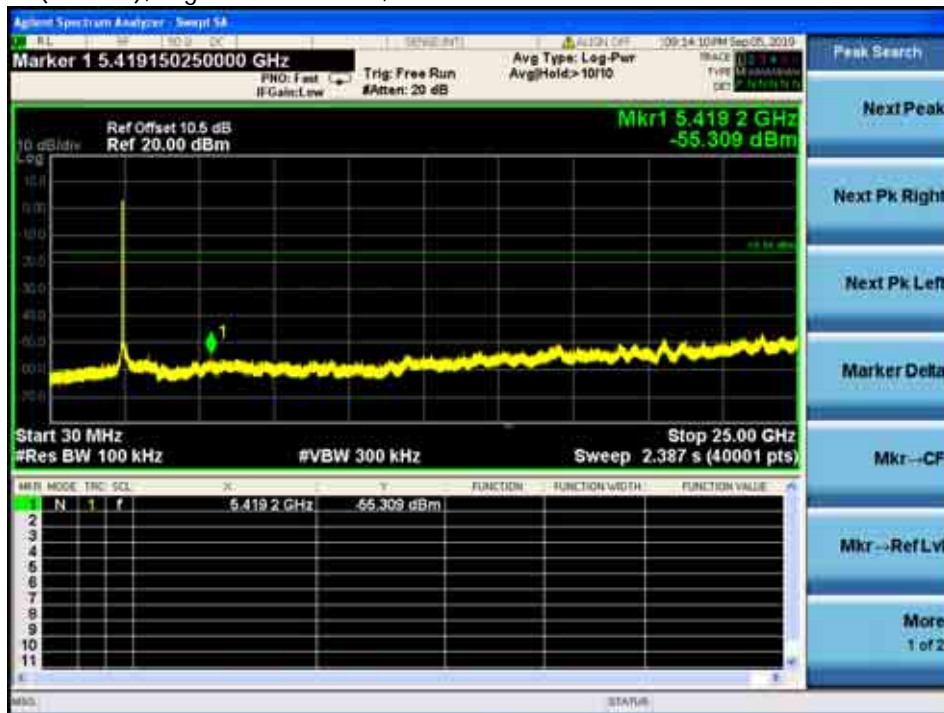

TEST REPORT

PLOTS OF OUT OF BAND CONDUCTED EMISSIONS

Ant.2_802.11n (20MHz), Highest Channel-3, Plot A



Ant.2_802.11n (20MHz), Highest Channel-3, Plot B

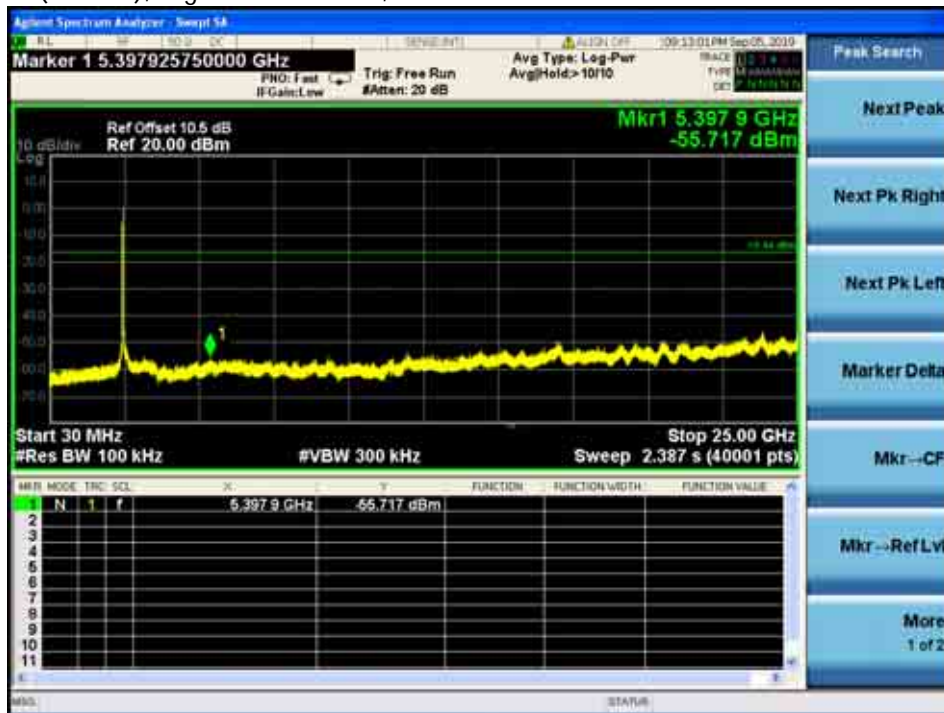

TEST REPORT

PLOTS OF OUT OF BAND CONDUCTED EMISSIONS

Ant.2_802.11n (20MHz), Highest Channel-3, Plot C



TEST REPORT

PLOTS OF OUT OF BAND CONDUCTED EMISSIONS

Ant.2_802.11n (40MHz), Lowest Channel, Plot A



Ant.2_802.11n (40MHz), Lowest Channel, Plot B

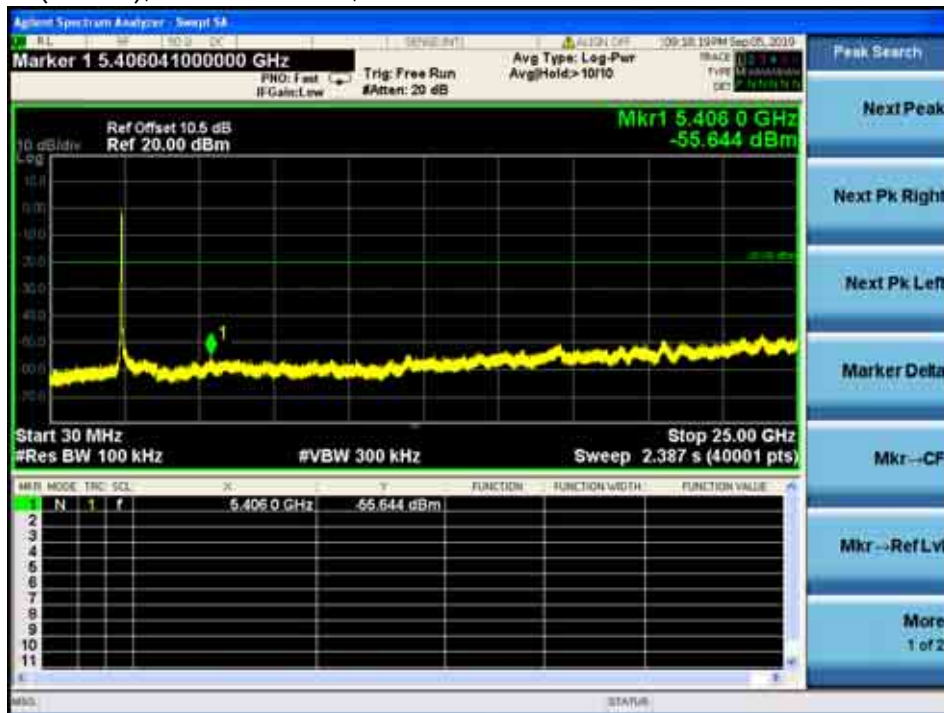

TEST REPORT

PLOTS OF OUT OF BAND CONDUCTED EMISSIONS

Ant.2_802.11n (40MHz), Lowest Channel, Plot C



TEST REPORT

PLOTS OF OUT OF BAND CONDUCTED EMISSIONS

Ant.2_802.11n (40MHz), Middle Channel, Plot A



Ant.2_802.11n (40MHz), Middle Channel, Plot B

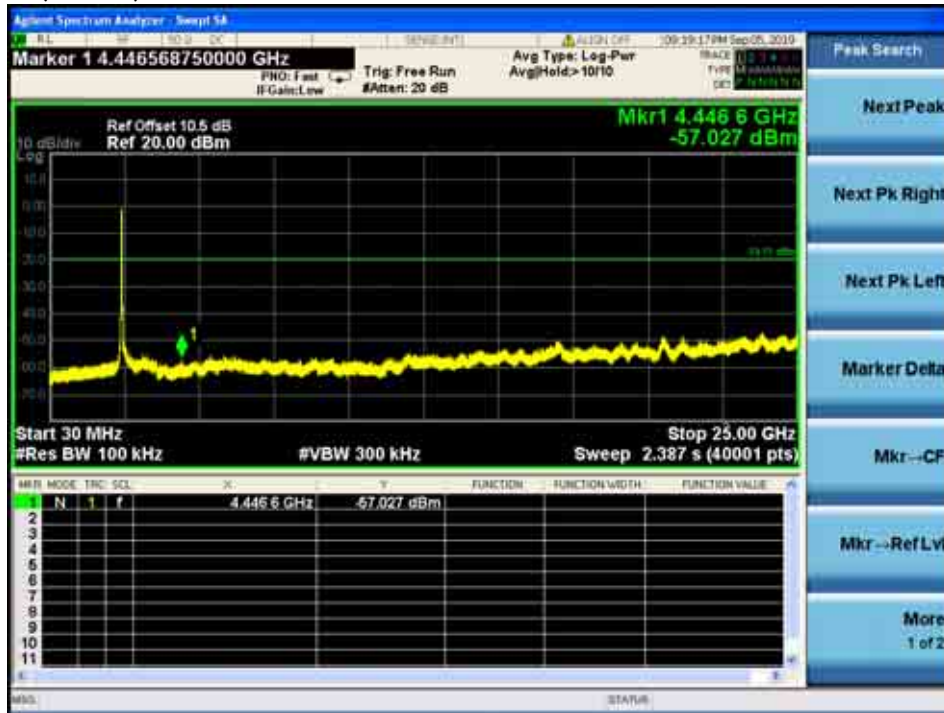

TEST REPORT

PLOTS OF OUT OF BAND CONDUCTED EMISSIONS

Ant.2_802.11n (40MHz), Highest Channel-1, Plot A



Ant.2_802.11n (40MHz), Highest Channel-1, Plot B

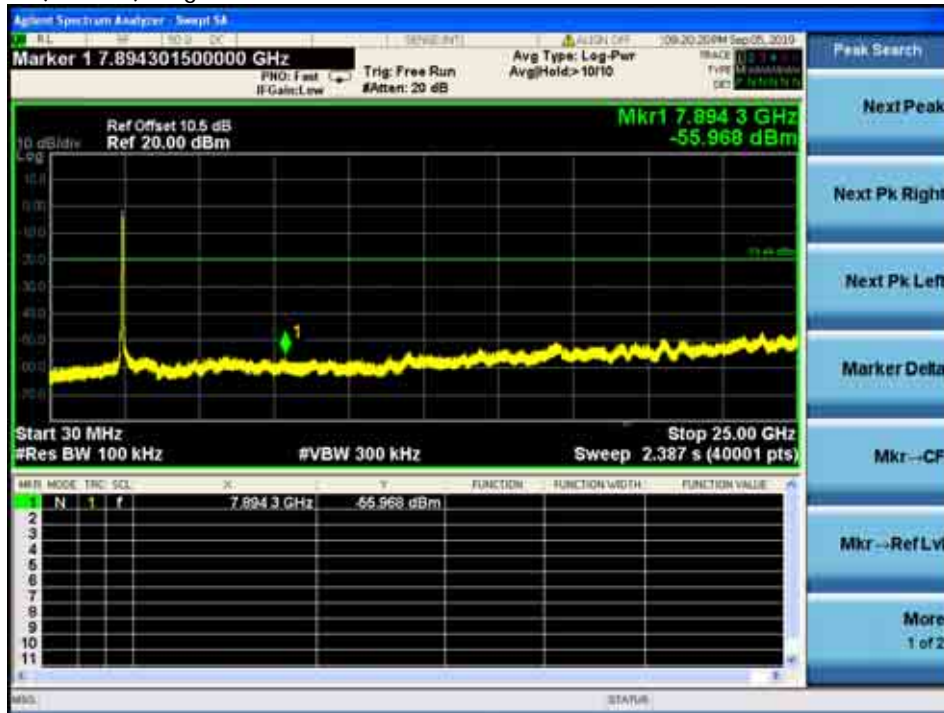

TEST REPORT

PLOTS OF OUT OF BAND CONDUCTED EMISSIONS

Ant.2_802.11n (40MHz), Highest Channel-1, Plot C



TEST REPORT

PLOTS OF OUT OF BAND CONDUCTED EMISSIONS

Ant.2_802.11n (40MHz), Highest Channel-1, Plot A



Ant.2_802.11n (40MHz), Highest Channel-1, Plot B

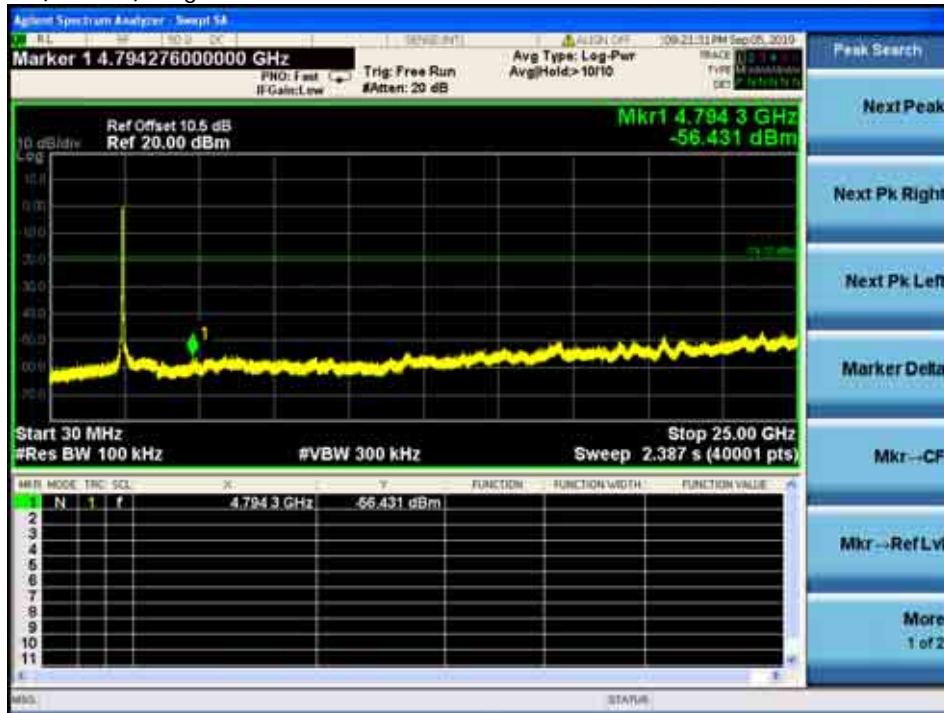

TEST REPORT

PLOTS OF OUT OF BAND CONDUCTED EMISSIONS

Ant.2_802.11n (40MHz), Highest Channel-1, Plot A



Ant.2_802.11n (40MHz), Highest Channel-1, Plot B

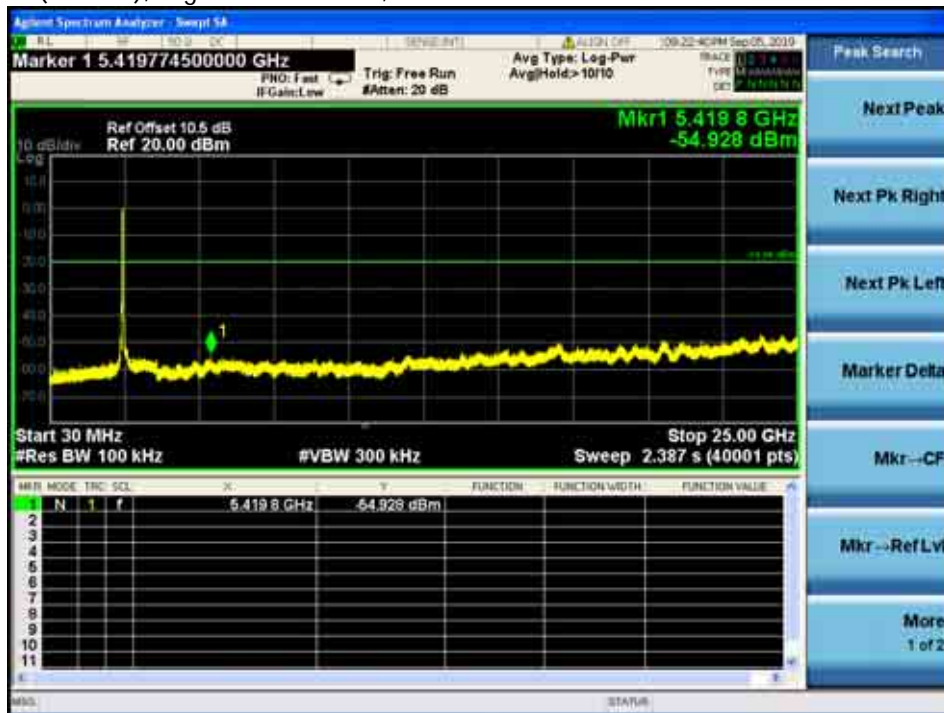

TEST REPORT

PLOTS OF OUT OF BAND CONDUCTED EMISSIONS

Ant.2_802.11n (40MHz), Highest Channel-1, Plot C



TEST REPORT

4.5 Field Strength Calculation

The field strength is calculated by adding the reading on the Spectrum Analyzer to the factors associated with preamplifiers (if any), antennas, cables, pulse desensitization and average factors (when specified limit is in average and measurements are made with peak detectors). A sample calculation is included below.

$$FS = RA + AF + CF - AG + PD + AV$$

Where FS = Field Strength in dB μ V/m

RA = Receiver Amplitude (including preamplifier) in dB μ V

CF = Cable Attenuation Factor in dB

AF = Antenna Factor in dB

AG = Amplifier Gain in dB

PD = Pulse Desensitization in dB

AV = Average Factor in -dB

In the radiated emission table which follows, the reading shown on the data table may reflect the preamplifier gain. An example of the calculations, where the reading does not reflect the preamplifier gain, follows:

$$FS = RA + AF + CF - AG + PD + AV$$

Example

Assume a receiver reading of 62.0 dB μ V is obtained. The antenna factor of 7.4 dB and cable factor of 1.6 dB is added. The amplifier gain of 29.0 dB is subtracted. The pulse desensitization factor of the spectrum analyzer is 0.0 dB, and the resultant average factor is -10.0 dB. The net field strength for comparison to the appropriate emission limit is 32.0 dB μ V/m. This value in dB μ V/m is converted to its corresponding level in μ V/m.

$$RA = 62.0 \text{ dB}\mu\text{V}$$

$$AF = 7.4 \text{ dB}$$

$$CF = 1.6 \text{ dB}$$

$$AG = 29.0 \text{ dB}$$

$$PD = 0.0 \text{ dB}$$

$$AV = -10 \text{ dB}$$

$$FS = 62.0 + 7.4 + 1.6 - 29.0 + 0.0 + (-10.0) = 32.0 \text{ dB}\mu\text{V/m}$$

$$\text{Level in } \mu\text{V/m} = \text{Common Antilogarithm } [(32.0 \text{ dB}\mu\text{V/m})/20] = 39.8 \mu\text{V/m}$$

TEST REPORT

4.6 Transmitter Radiated Emissions in Restricted Bands and Spurious Emissions

Data is included of the worst case configuration (the configuration which resulted in the highest emission levels). A sample calculation, configuration photographs and data tables of the emissions are included.

The data on the following pages list the significant emission frequencies, the limit and the margin of compliance.

4.6.1 Radiated Emission Configuration Photograph

Worst Case Restricted Band Radiated Emission
at

2483.5 MHz

The worst case radiated emission configuration photographs are saved with filename: config photos.pdf

4.6.2 Radiated Emission Data

The data in tables 1-5 list the significant emission frequencies, the limit and the margin of compliance.

Judgement -

Passed by 0.39 dB margin

TEST REPORT

RADIATED EMISSION DATA

Ant. 1_Table 1
IEEE 802.11b (DSSS, 1 Mbps)

Radiated Emission Test Data (Above 1GHz):

IEEE 802.11b_Lowest Channel:

No.	Frequency (MHz)	Reading (dBuV/m)	Correction factor (dB)	Result (dBuV/m)	Limit (dBuV/m)	Margin (dB)	Detector	Antenna Polaxis
1	4824.00	27.80	13.90	41.70	74.00	32.30	Peak	Horizontal
2	4824.00	10.20	13.90	24.10	54.00	29.90	Average	Horizontal
3	7236.00	39.30	7.30	46.60	74.00	27.40	Peak	Horizontal
4	7236.00	26.40	7.30	33.70	54.00	20.30	Average	Horizontal
5	4824.00	36.40	4.90	41.30	74.00	32.70	Peak	Vertical
6	4824.00	24.70	4.90	29.60	54.00	24.40	Average	Vertical
7	7236.00	38.50	6.30	44.80	74.00	29.20	Peak	Vertical
8	7236.00	26.90	6.30	33.20	54.00	20.80	Average	Vertical

IEEE 802.11b_Middle Channel:

No.	Frequency (MHz)	Reading (dBuV/m)	Correction factor (dB)	Result (dBuV/m)	Limit (dBuV/m)	Margin (dB)	Detector	Antenna Polaxis
1	4874.00	43.60	3.90	47.50	74.00	26.50	Peak	Horizontal
2	4874.00	27.70	3.90	31.60	54.00	22.40	Average	Horizontal
3	7311.00	39.50	6.90	46.40	74.00	27.60	Peak	Horizontal
4	7311.00	27.70	6.90	34.60	54.00	19.40	Average	Horizontal
5	4874.00	44.30	4.90	49.20	74.00	24.80	Peak	Vertical
6	4874.00	28.40	4.90	33.30	54.00	20.70	Average	Vertical
7	7311.00	41.00	6.50	47.50	74.00	26.50	Peak	Vertical
8	7311.00	29.00	6.50	35.50	54.00	18.50	Average	Vertical

IEEE 802.11b_Highest Channel-1:

No.	Frequency (MHz)	Reading (dBuV/m)	Correction factor (dB)	Result (dBuV/m)	Limit (dBuV/m)	Margin (dB)	Detector	Antenna Polaxis
1	4924.00	40.50	4.00	44.50	74.00	29.50	Peak	Horizontal
2	4924.00	26.00	4.00	30.00	54.00	24.00	Average	Horizontal
3	7386.00	38.00	7.10	45.10	74.00	28.90	Peak	Horizontal
4	7386.00	26.80	7.10	33.90	54.00	20.10	Average	Horizontal
5	4924.00	36.70	5.00	41.70	74.00	32.30	Peak	Vertical
6	4924.00	24.30	5.00	29.30	54.00	24.70	Average	Vertical
7	7386.00	38.00	6.60	44.60	74.00	29.40	Peak	Vertical
8	7386.00	26.70	6.60	33.30	54.00	20.70	Average	Vertical

TEST REPORT

IEEE 802.11b_Highest Channel-2:

No.	Frequency (MHz)	Reading (dBuV/m)	Correction factor (dB)	Result (dBuV/m)	Limit (dBuV/m)	Margin (dB)	Detector	Antenna Polaxis
1	4934.00	39.00	4.10	43.10	74.00	30.90	Peak	Horizontal
2	4934.00	28.70	4.10	32.80	54.00	21.20	Average	Horizontal
3	7401.00	39.60	7.10	46.70	74.00	27.30	Peak	Horizontal
4	7401.00	28.40	7.10	35.50	54.00	18.50	Average	Horizontal
5	4934.00	39.90	5.10	45.00	74.00	29.00	Peak	Vertical
6	4934.00	28.20	5.10	33.30	54.00	20.70	Average	Vertical
7	7401.00	40.40	6.60	47.00	74.00	27.00	Peak	Vertical
8	7401.00	29.00	6.60	35.60	54.00	18.40	Average	Vertical

IEEE 802.11b_Highest Channel-3:

No.	Frequency (MHz)	Reading (dBuV/m)	Correction factor (dB)	Result (dBuV/m)	Limit (dBuV/m)	Margin (dB)	Detector	Antenna Polaxis
1	4944.00	39.20	4.10	43.30	74.00	30.70	Peak	Horizontal
2	4944.00	27.20	4.10	31.30	54.00	22.70	Average	Horizontal
3	7416.00	40.70	7.10	47.80	74.00	26.20	Peak	Horizontal
4	7416.00	29.10	7.10	36.20	54.00	17.80	Average	Horizontal
5	4944.00	39.20	5.10	44.30	74.00	29.70	Peak	Vertical
6	4944.00	28.40	5.10	33.50	54.00	20.50	Average	Vertical
7	7416.00	41.40	6.60	48.00	74.00	26.00	Peak	Vertical
8	7416.00	29.20	6.60	35.80	54.00	18.20	Average	Vertical

TEST REPORT

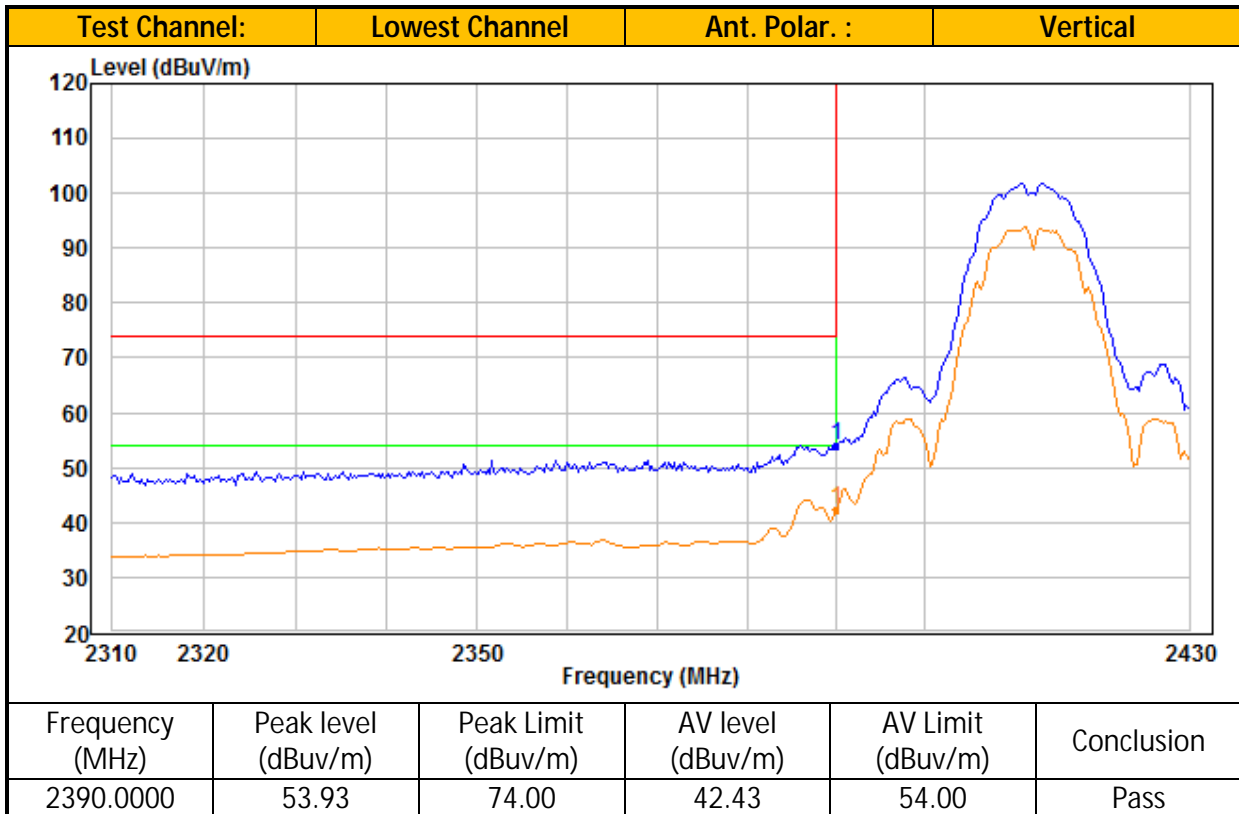
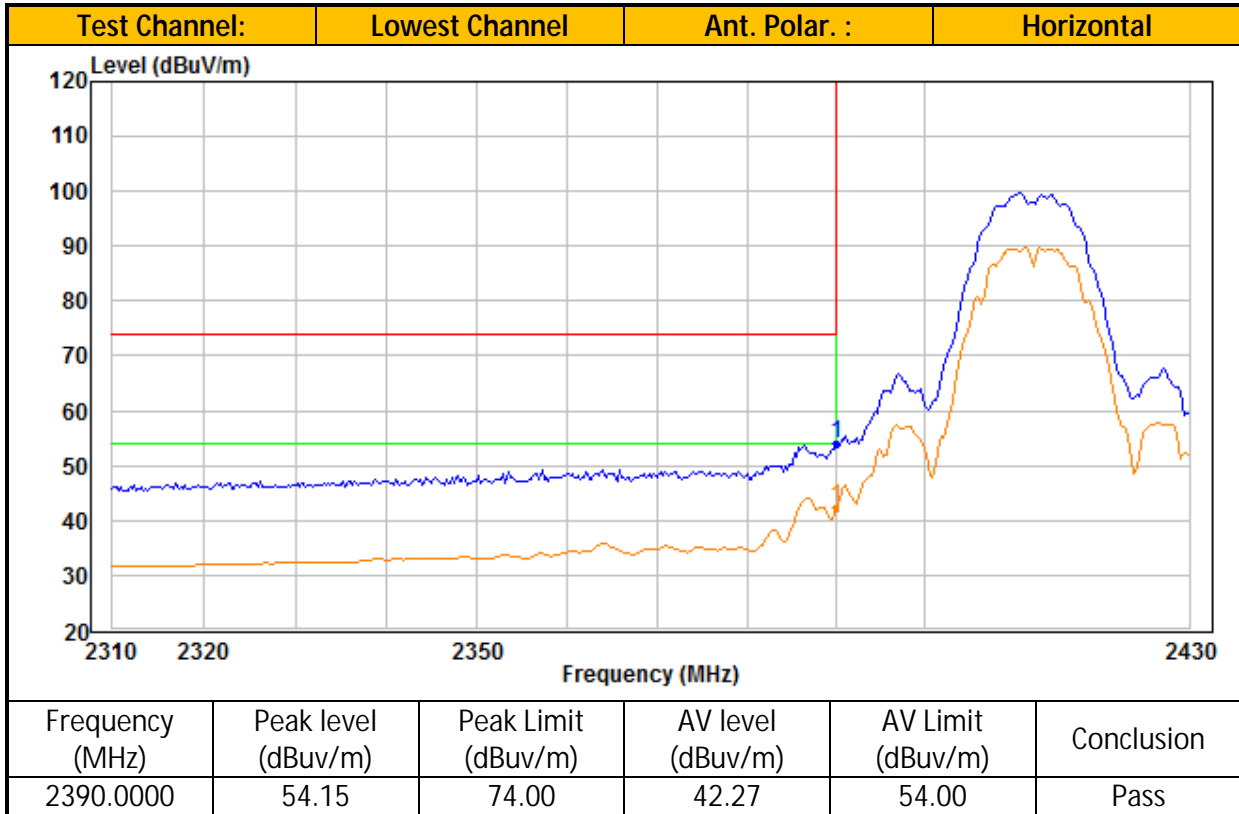

TEST REPORT

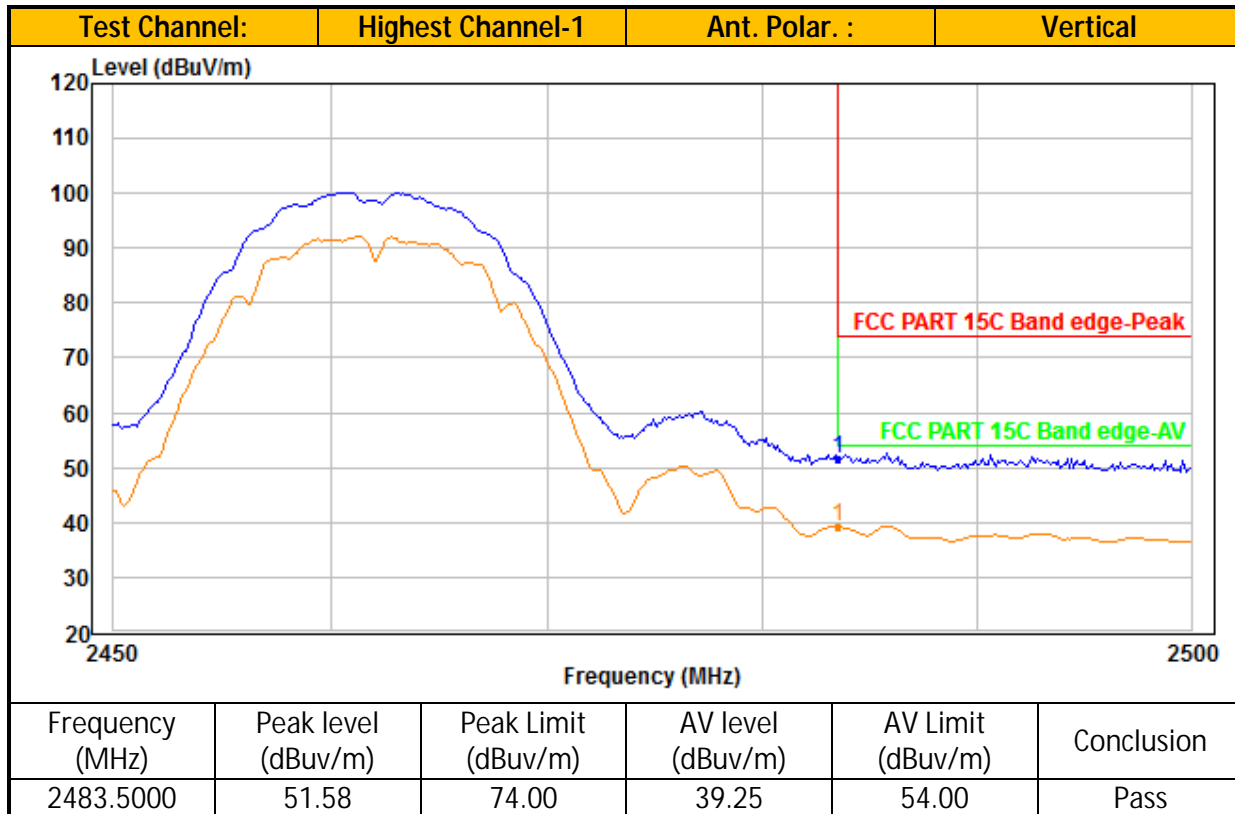
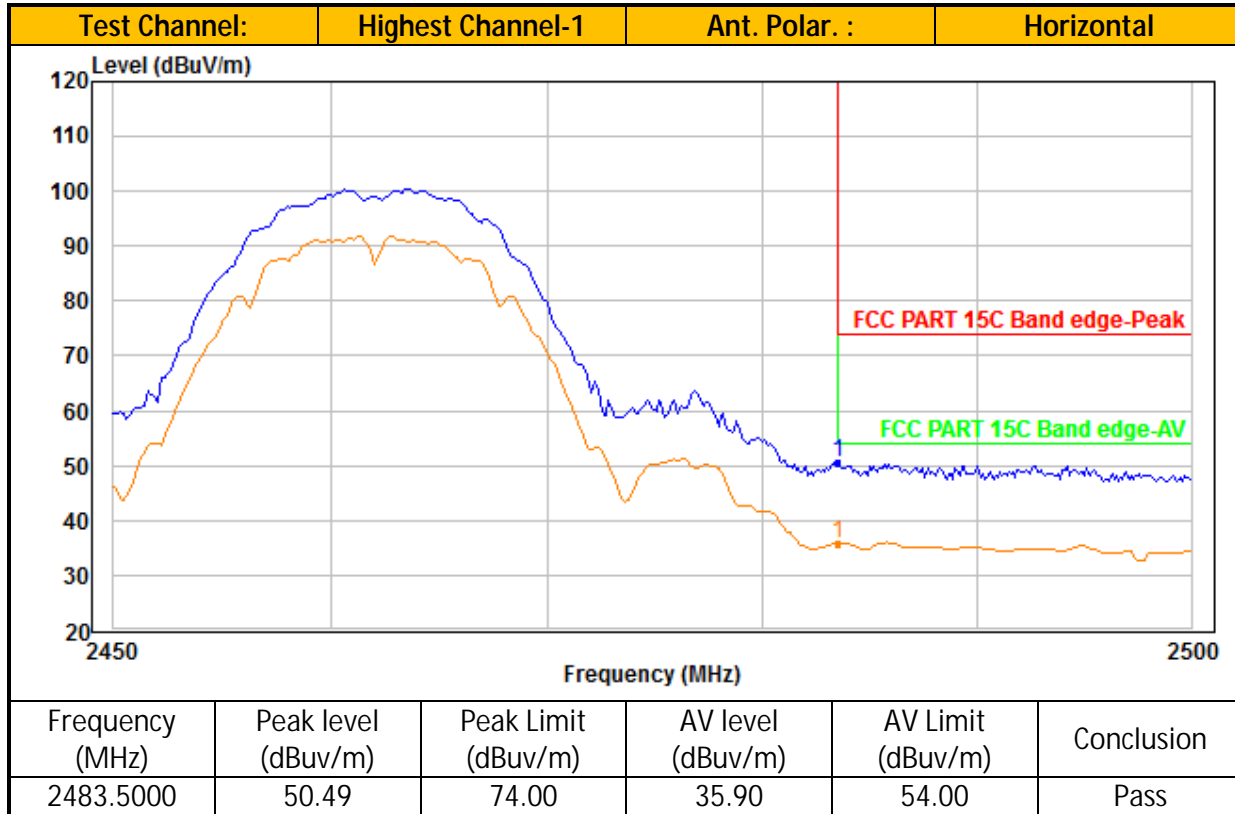

TEST REPORT

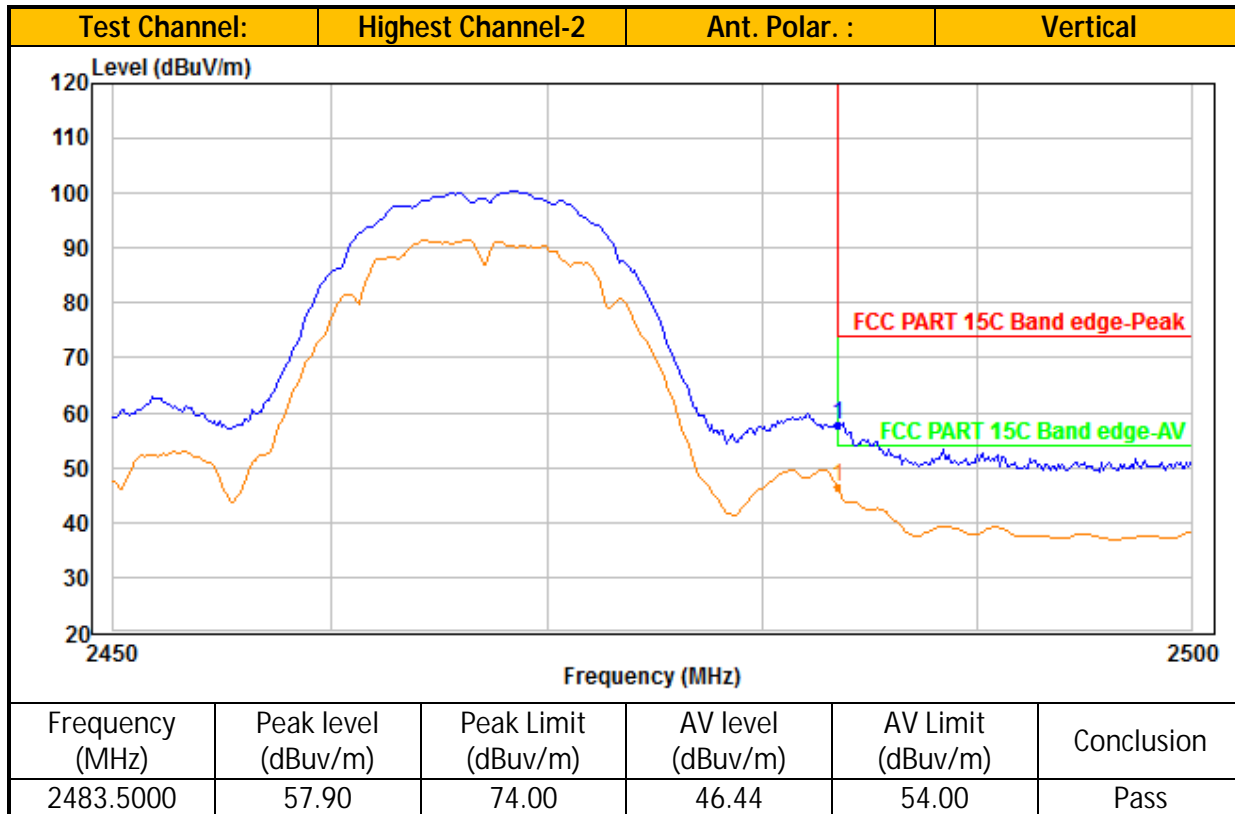
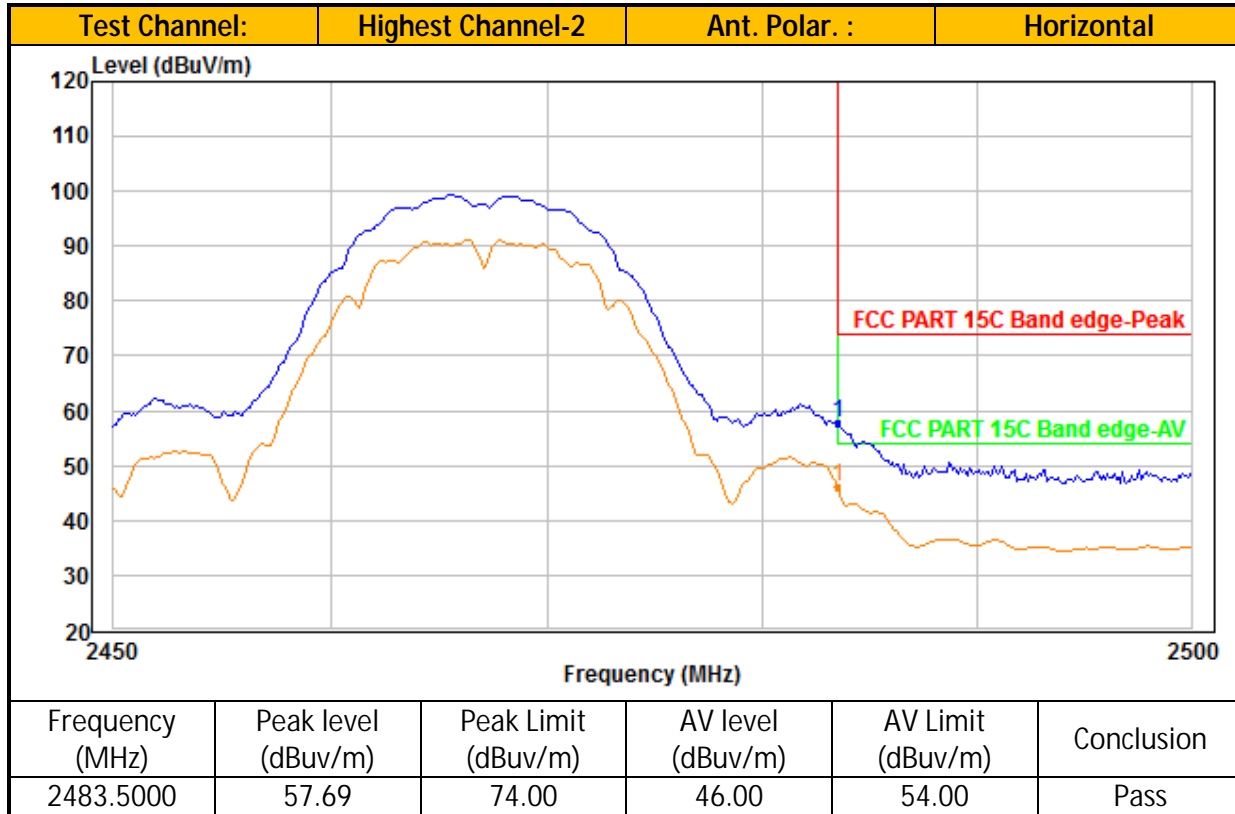

TEST REPORT

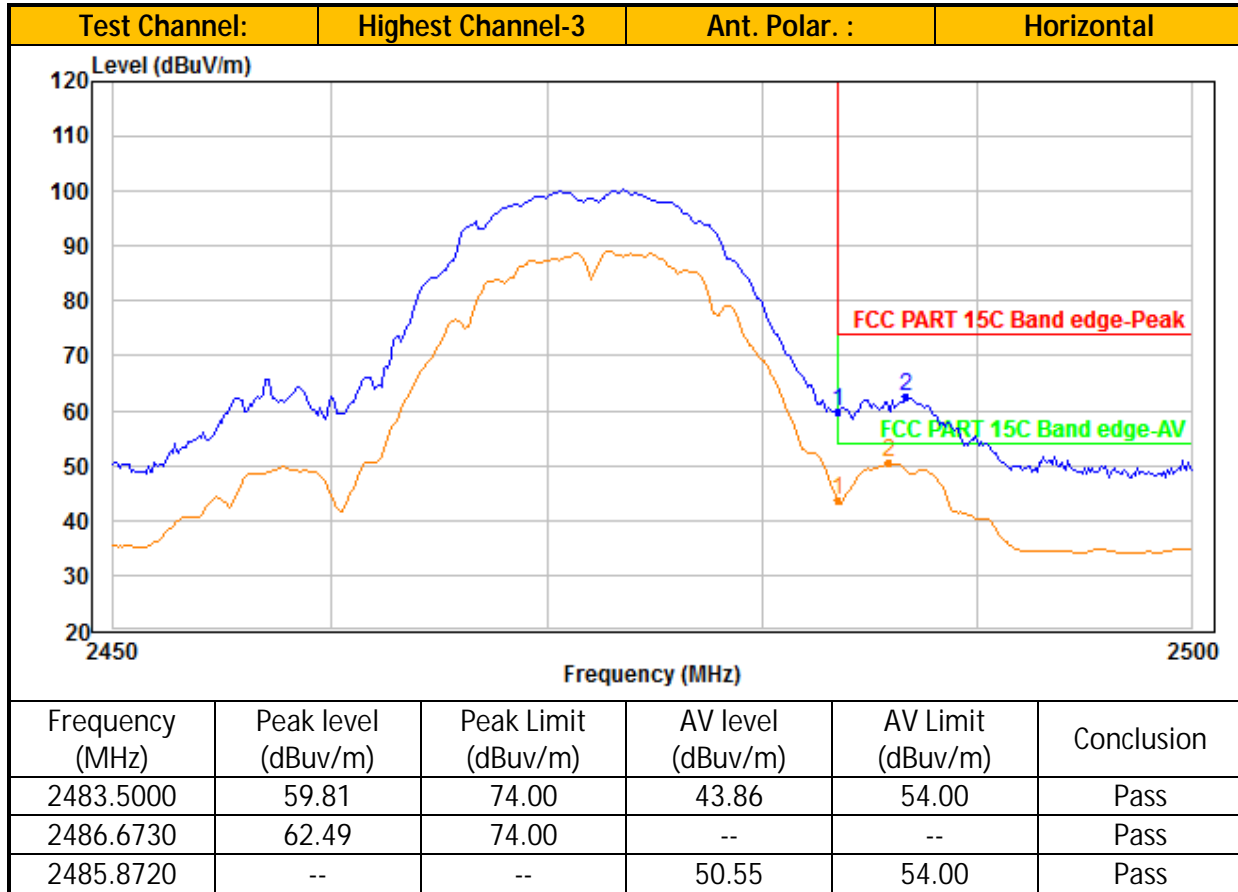

TEST REPORT

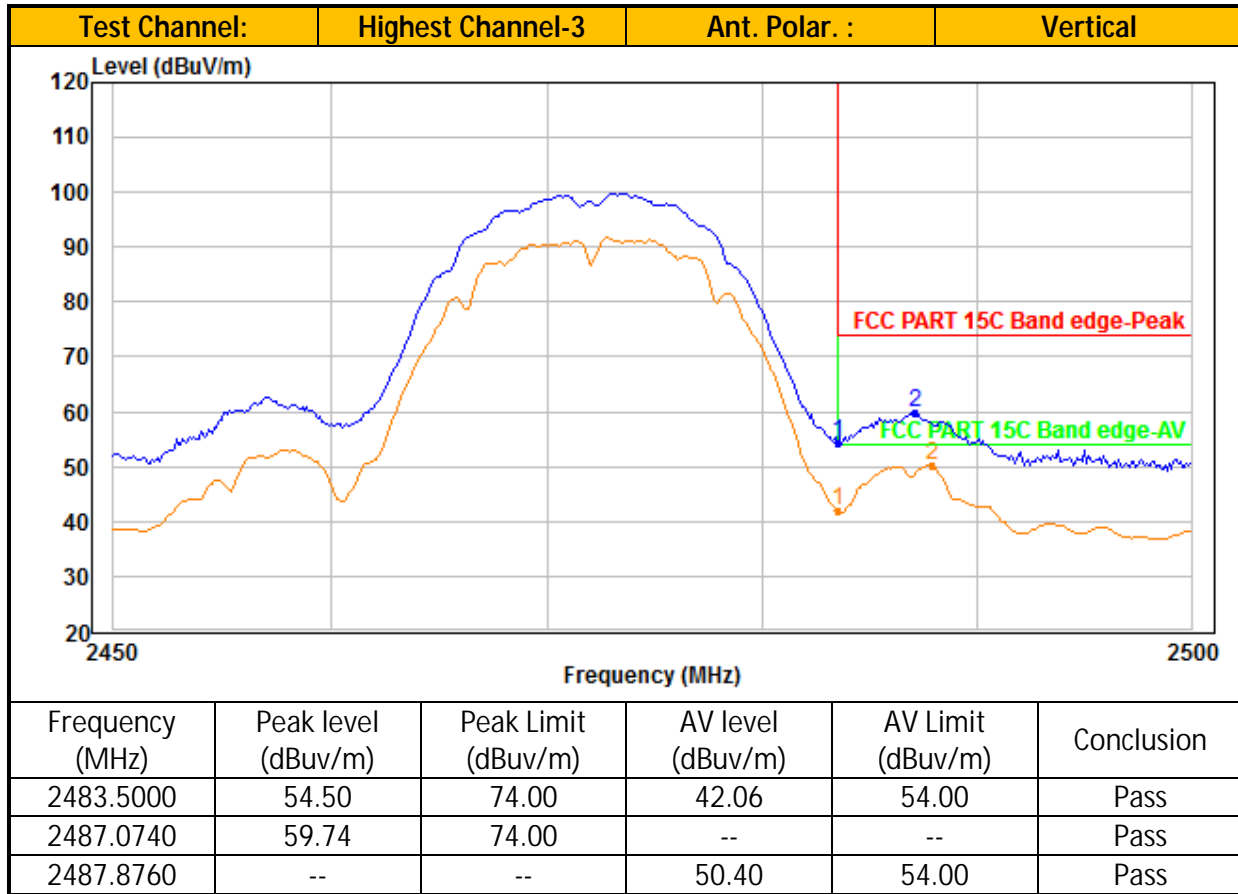

TEST REPORT

Ant. 2_Table 2
IEEE 802.11b (DSSS, 1 Mbps)

Radiated Emission Test Data (Above 1GHz):
IEEE 802.11b_Lowest Channel:

No.	Frequency (MHz)	Reading (dBuV/m)	Correction factor (dB)	Result (dBuV/m)	Limit (dBuV/m)	Margin (dB)	Detector	Antenna Polaxis
1	4824.00	36.00	3.90	39.90	74.00	34.10	Peak	Horizontal
2	4824.00	24.70	3.90	28.60	54.00	25.40	Average	Horizontal
3	7236.00	39.30	6.80	46.10	74.00	27.90	Peak	Horizontal
4	7236.00	27.50	6.80	34.30	54.00	19.70	Average	Horizontal
5	4824.00	37.90	4.90	42.80	74.00	31.20	Peak	Vertical
6	4824.00	26.40	4.90	31.30	54.00	22.70	Average	Vertical
7	7236.00	40.00	6.30	46.30	74.00	27.70	Peak	Vertical
8	7236.00	27.90	6.30	34.20	54.00	19.80	Average	Vertical

IEEE 802.11b_Middle Channel:

No.	Frequency (MHz)	Reading (dBuV/m)	Correction factor (dB)	Result (dBuV/m)	Limit (dBuV/m)	Margin (dB)	Detector	Antenna Polaxis
1	4874.00	39.60	3.90	43.50	74.00	30.50	Peak	Horizontal
2	4874.00	26.00	3.90	29.90	54.00	24.10	Average	Horizontal
3	7311.00	39.90	6.90	46.80	74.00	27.20	Peak	Horizontal
4	7311.00	28.00	6.90	34.90	54.00	19.10	Average	Horizontal
5	4874.00	41.80	4.90	46.70	74.00	27.30	Peak	Vertical
6	4874.00	28.00	4.90	32.90	54.00	21.10	Average	Vertical
7	7311.00	39.10	6.50	45.60	74.00	28.40	Peak	Vertical
8	7311.00	28.10	6.50	34.60	54.00	19.40	Average	Vertical

IEEE 802.11b_Highest Channel-1:

No.	Frequency (MHz)	Reading (dBuV/m)	Correction factor (dB)	Result (dBuV/m)	Limit (dBuV/m)	Margin (dB)	Detector	Antenna Polaxis
1	4924.00	41.30	4.00	45.30	74.00	28.70	Peak	Horizontal
2	4924.00	26.80	4.00	30.80	54.00	23.20	Average	Horizontal
3	7386.00	40.00	7.10	47.10	74.00	26.90	Peak	Horizontal
4	7386.00	27.90	7.10	35.00	54.00	19.00	Average	Horizontal
5	4924.00	43.30	5.00	48.30	74.00	25.70	Peak	Vertical
6	4924.00	28.50	5.00	33.50	54.00	20.50	Average	Vertical
7	7386.00	39.40	6.60	46.00	74.00	28.00	Peak	Vertical
8	7386.00	28.00	6.60	34.60	54.00	19.40	Average	Vertical

TEST REPORT

IEEE 802.11b_Highest Channel-2:

No.	Frequency (MHz)	Reading (dBuV/m)	Correction factor (dB)	Result (dBuV/m)	Limit (dBuV/m)	Margin (dB)	Detector	Antenna Polaxis
1	4934.00	40.30	4.10	44.40	74.00	29.60	Peak	Horizontal
2	4934.00	28.40	4.10	32.50	54.00	21.50	Average	Horizontal
3	7401.00	41.00	7.10	48.10	74.00	25.90	Peak	Horizontal
4	7401.00	29.10	7.10	36.20	54.00	17.80	Average	Horizontal
5	4934.00	38.80	5.10	43.90	74.00	30.10	Peak	Vertical
6	4934.00	28.40	5.10	33.50	54.00	20.50	Average	Vertical
7	7401.00	41.40	6.60	48.00	74.00	26.00	Peak	Vertical
8	7401.00	29.00	6.60	35.60	54.00	18.40	Average	Vertical

IEEE 802.11b_Highest Channel-3:

No.	Frequency (MHz)	Reading (dBuV/m)	Correction factor (dB)	Result (dBuV/m)	Limit (dBuV/m)	Margin (dB)	Detector	Antenna Polaxis
1	4944.00	44.50	4.10	48.60	74.00	25.40	Peak	Horizontal
2	4944.00	29.40	4.10	33.50	54.00	20.50	Average	Horizontal
3	7416.00	40.30	7.10	47.40	74.00	26.60	Peak	Horizontal
4	7416.00	29.20	7.10	36.30	54.00	17.70	Average	Horizontal
5	4944.00	43.60	5.10	48.70	74.00	25.30	Peak	Vertical
6	4944.00	29.10	5.10	34.20	54.00	19.80	Average	Vertical
7	7416.00	40.90	6.60	47.50	74.00	26.50	Peak	Vertical
8	7416.00	29.10	6.60	35.70	54.00	18.30	Average	Vertical

TEST REPORT

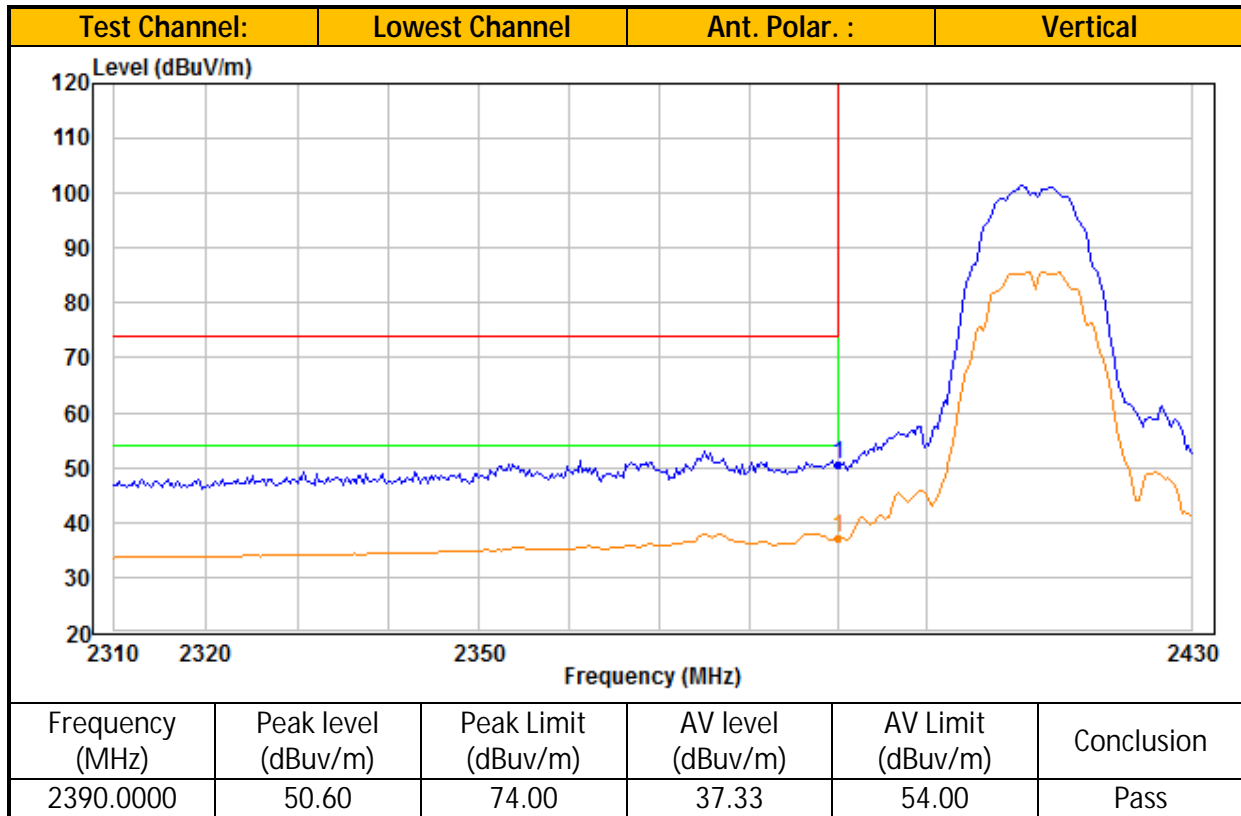
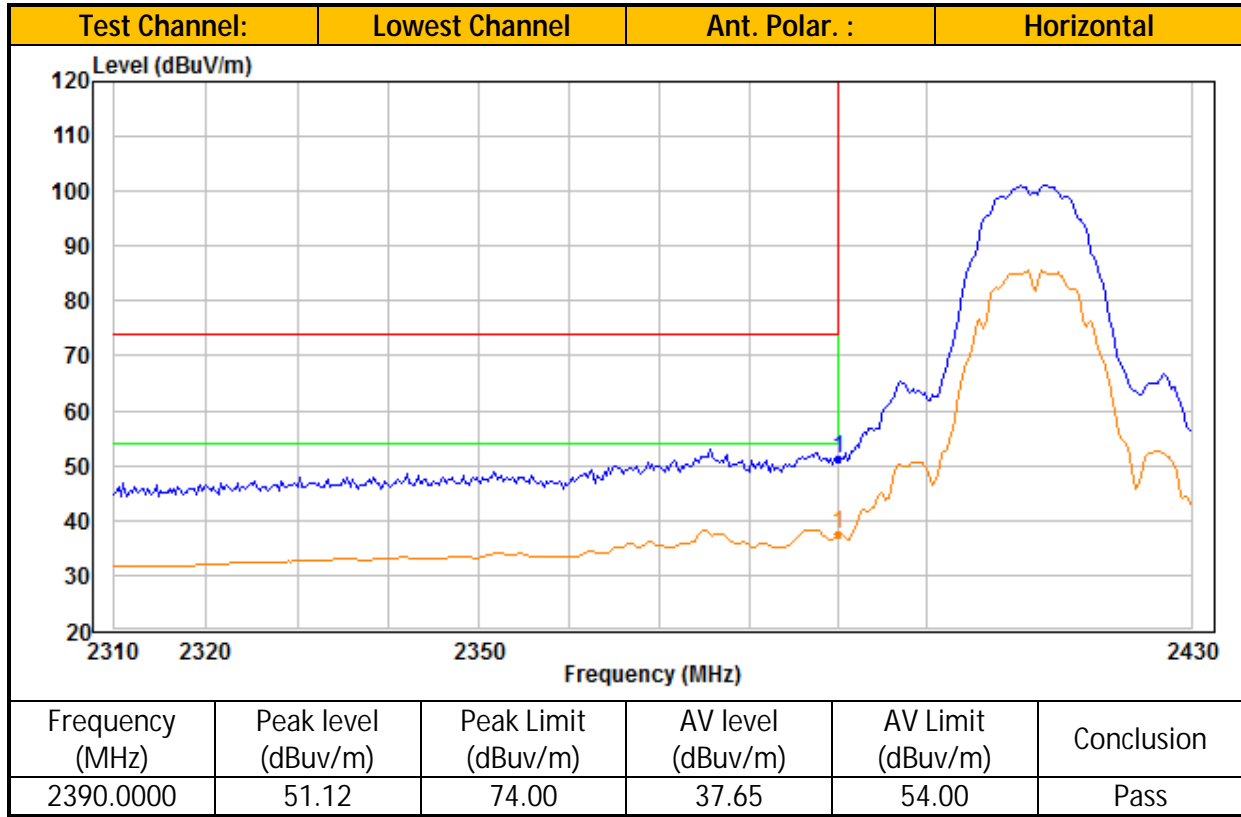

TEST REPORT

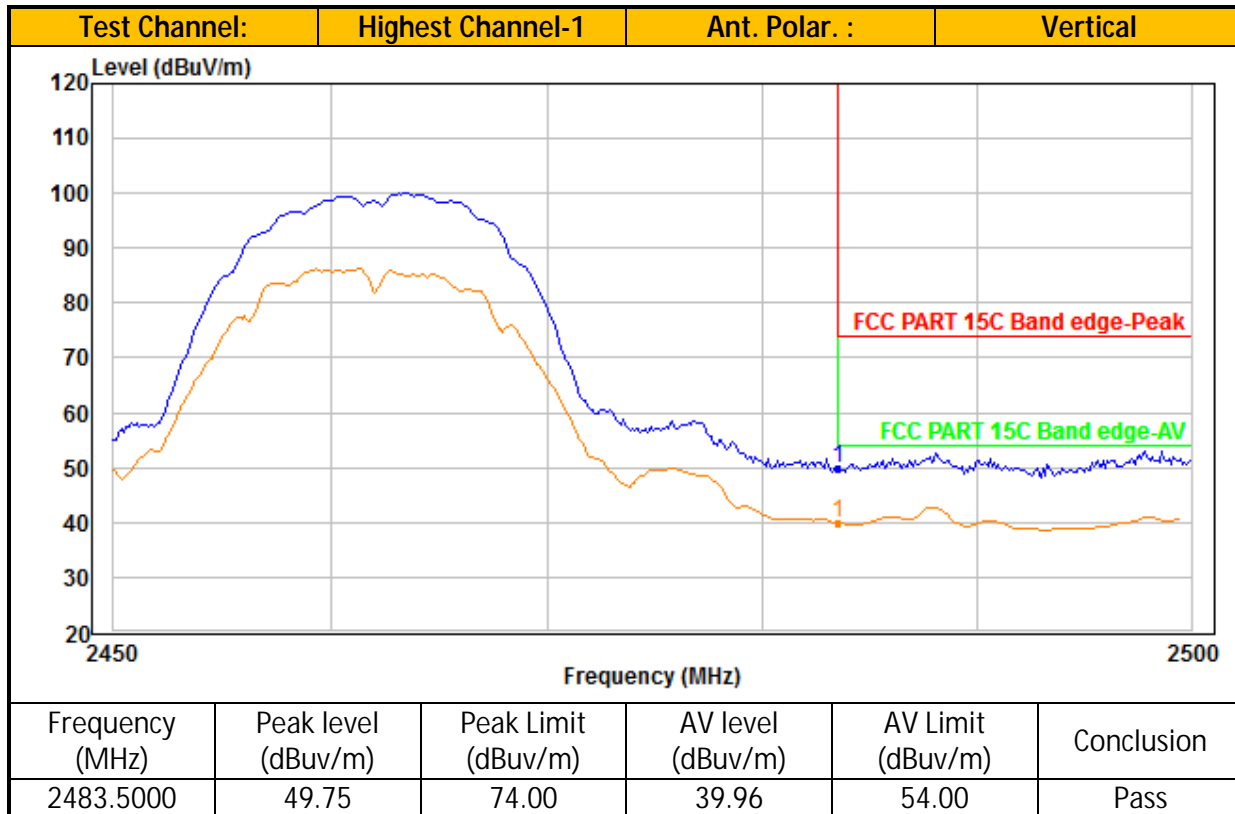
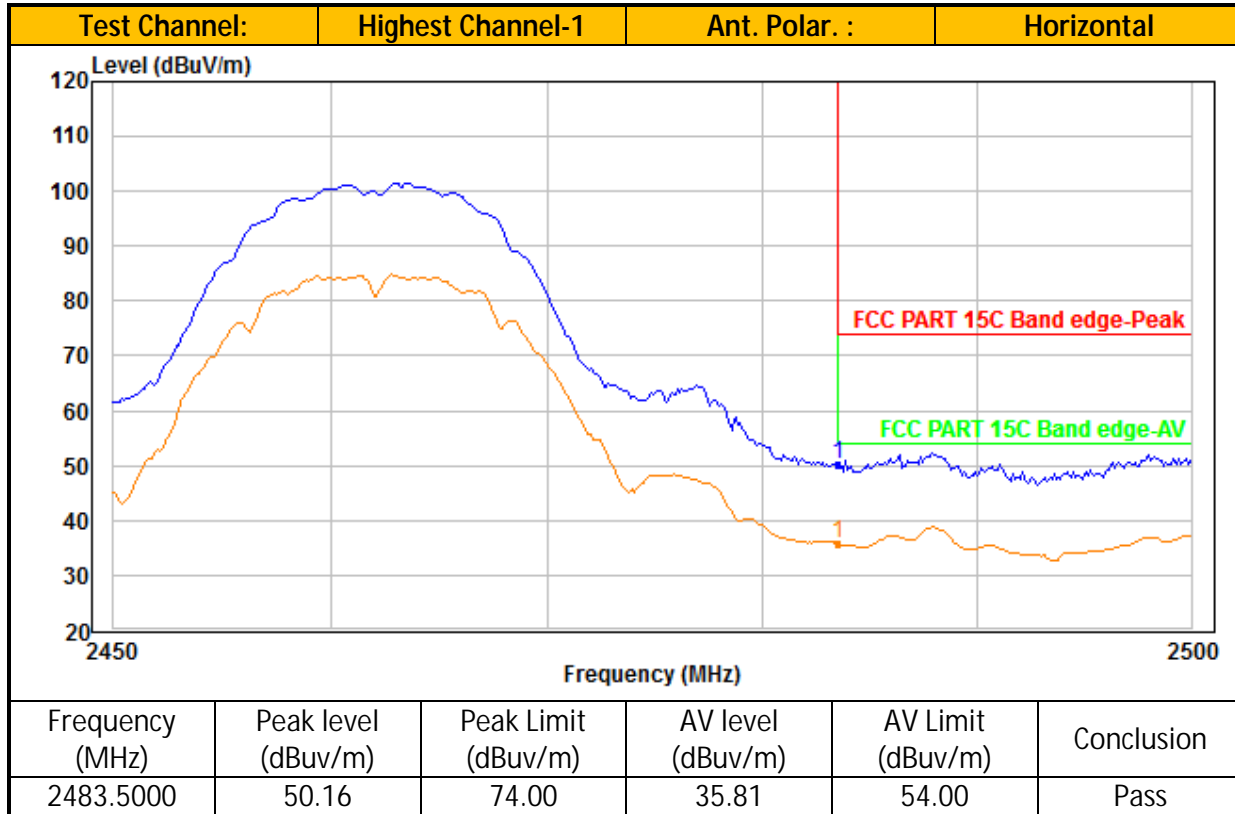

TEST REPORT

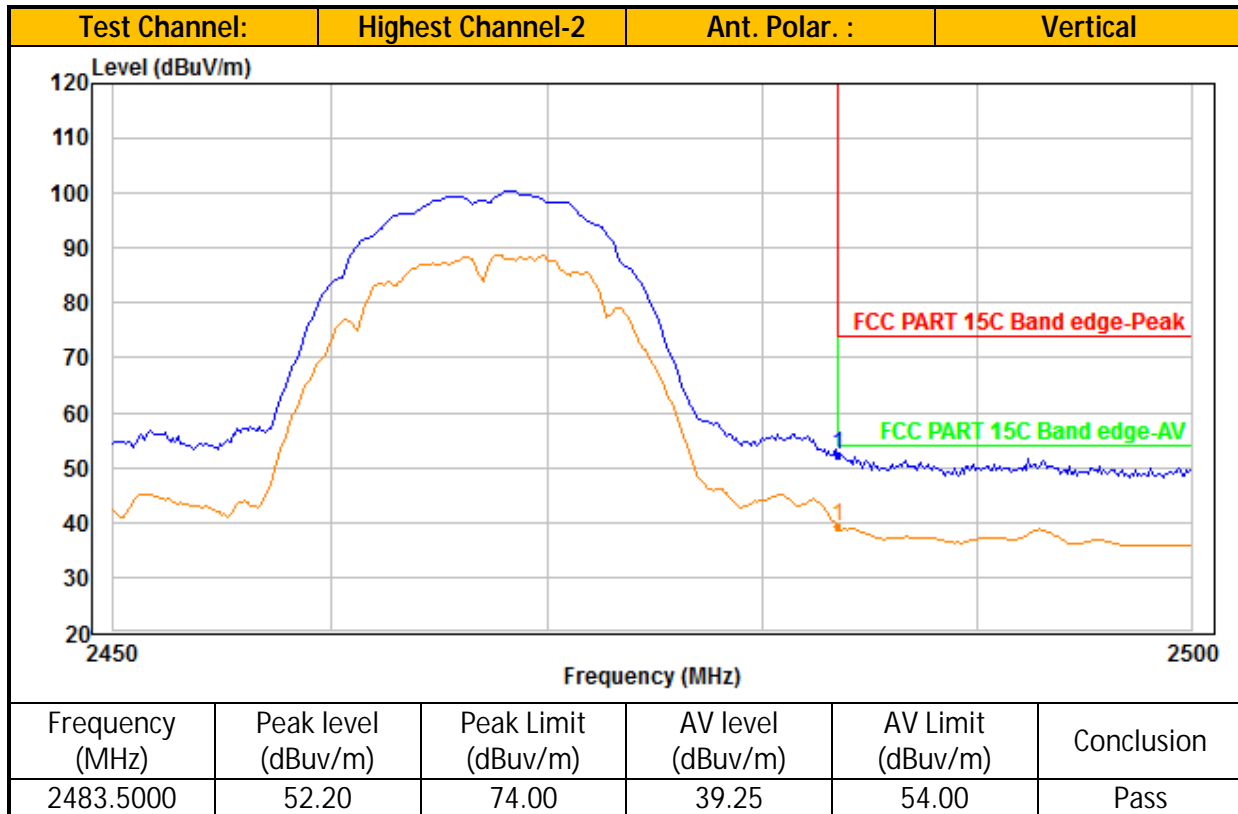
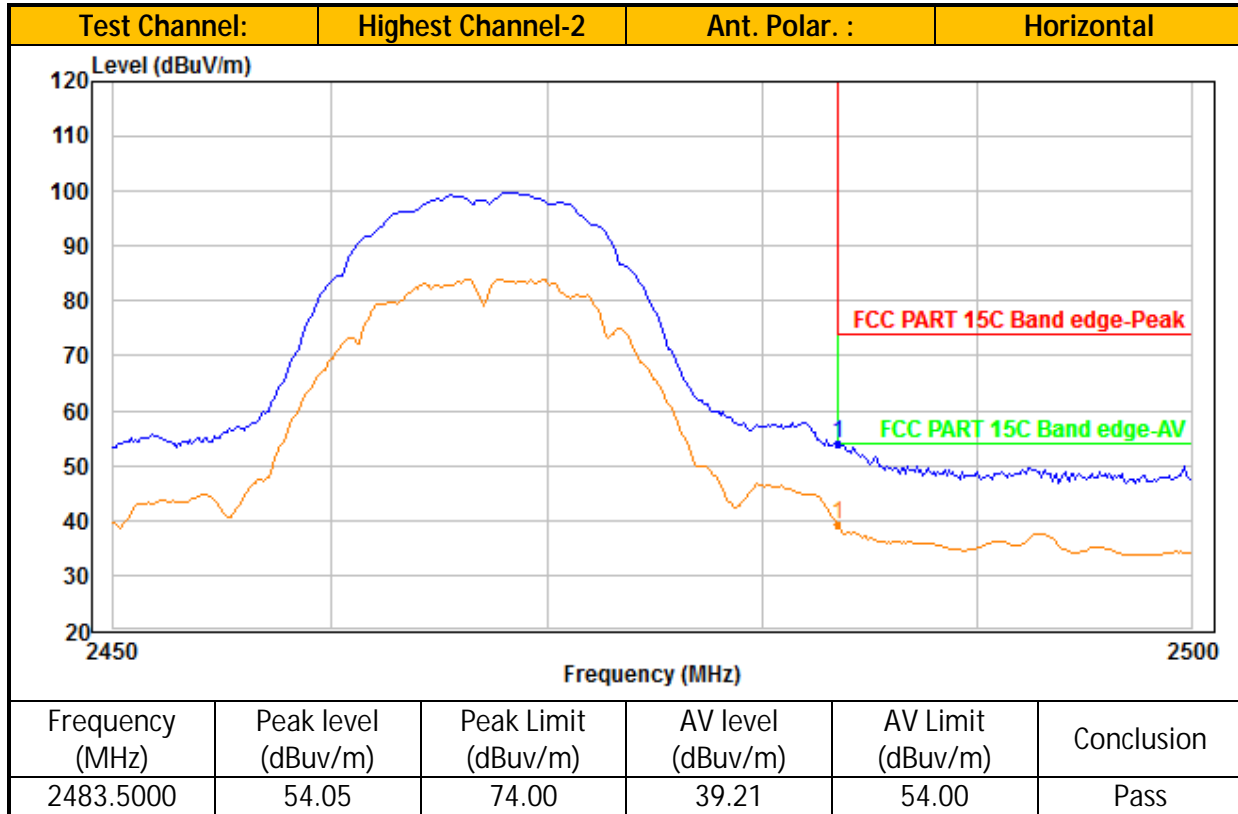

TEST REPORT

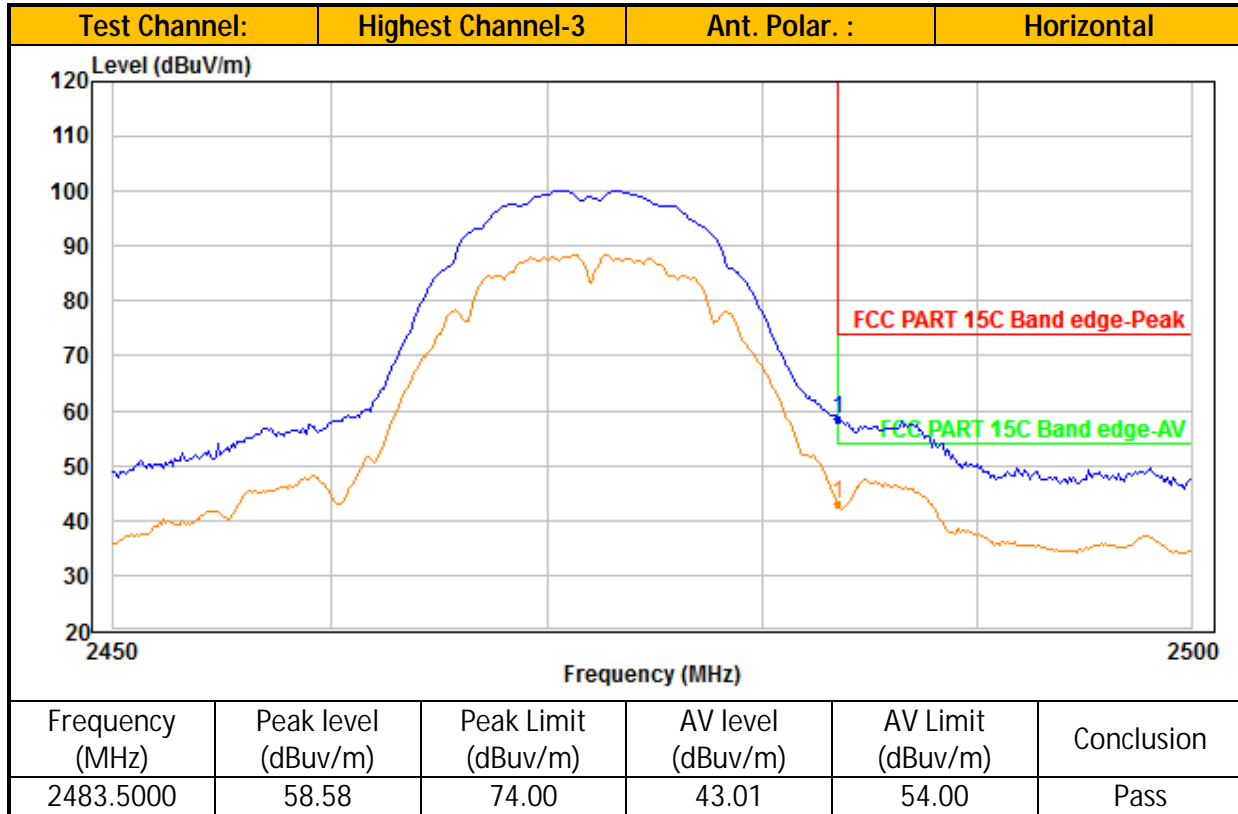

TEST REPORT

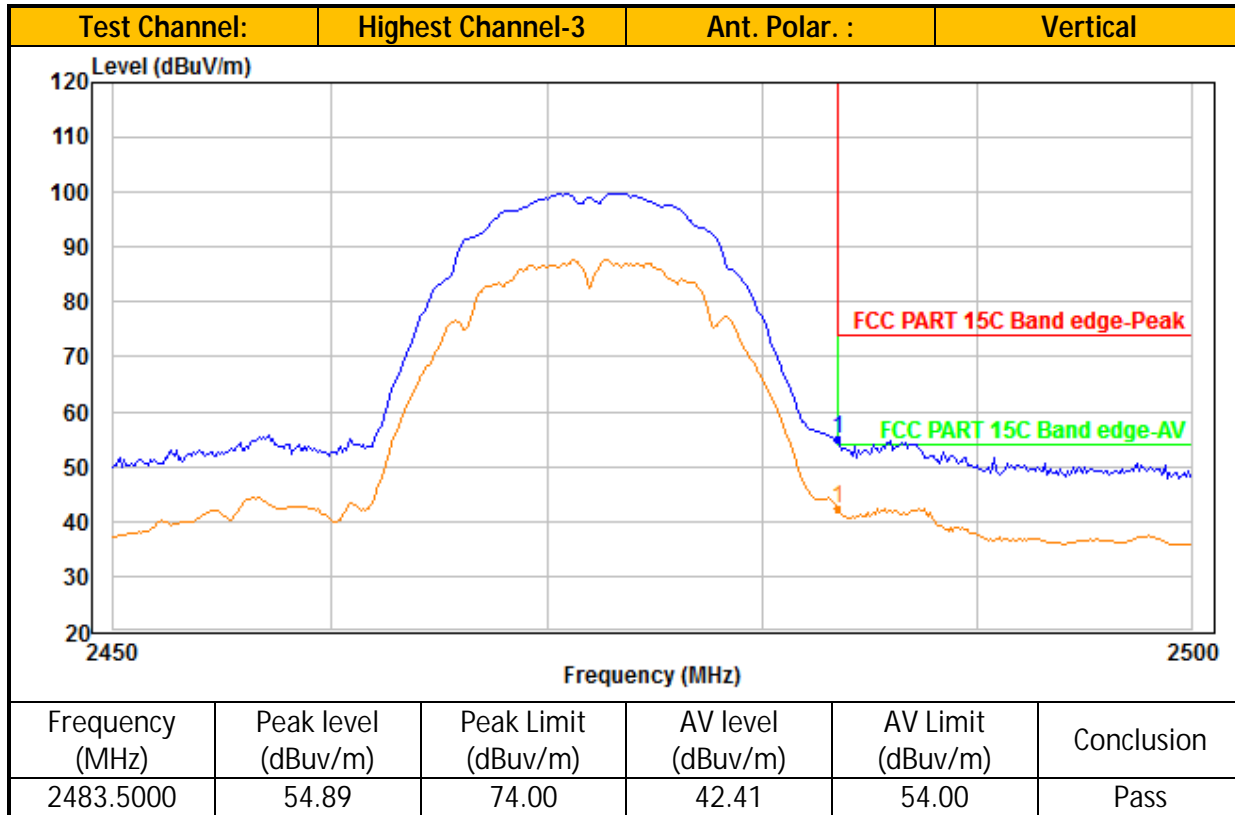

- NOTES:
1. Peak detector is used for the emission measurement.
 2. Average detector is used for the average data of emission measurement
 3. All measurements were made at 3 meters. Radiated emissions not detected at the 3-meter distance were measured at 0.3-meter and an inverse proportional extrapolation was performed to compare the signal level to the 3-meter limit. No other radiated emissions than those reported were detected at a test distance of 0.3-meter.
 4. Value in the margin column shows emission below limit.
 5. Horn antenna is used for the emission over 1000MHz.
 6. Emission (the row indicated by ***bold italic***) within the restricted band meets the requirement of FCC Part 15 Section 15.205.
 7. For the measurement of radiated emission, summation method was used which numerical integrating (in terms of linear power) over the transmitter occupied bandwidth.
 8. For the linear power measurement, data in 1MHz spacing was collected by spectrum analyzer with 1MHz resolution bandwidth.

TEST REPORT

Ant. 1_Table 2
IEEE 802.11g (OFDM, 6 Mbps)

Radiated Emission Test Data (Above 1GHz):
IEEE 802.11g_Lowest Channel:

No.	Frequency (MHz)	Reading (dBuV/m)	Correction factor (dB)	Result (dBuV/m)	Limit (dBuV/m)	Margin (dB)	Detector	Antenna Polaxis
1	4824.00	35.90	3.90	39.80	74.00	34.20	Peak	Horizontal
2	4824.00	24.80	3.90	28.70	54.00	25.30	Average	Horizontal
3	7236.00	38.50	6.80	45.30	74.00	28.70	Peak	Horizontal
4	7236.00	27.00	6.80	33.80	54.00	20.20	Average	Horizontal
5	4824.00	35.80	4.90	40.70	74.00	33.30	Peak	Vertical
6	4824.00	24.80	4.90	29.70	54.00	24.30	Average	Vertical
7	7236.00	38.20	6.30	44.50	74.00	29.50	Peak	Vertical
8	7236.00	26.90	6.30	33.20	54.00	20.80	Average	Vertical

IEEE 802.11g_Middle Channel:

No.	Frequency (MHz)	Reading (dBuV/m)	Correction factor (dB)	Result (dBuV/m)	Limit (dBuV/m)	Margin (dB)	Detector	Antenna Polaxis
1	4874.00	38.30	3.90	42.20	74.00	31.80	Peak	Horizontal
2	4874.00	27.20	3.90	31.10	54.00	22.90	Average	Horizontal
3	7311.00	38.80	6.90	45.70	74.00	28.30	Peak	Horizontal
4	7311.00	27.70	6.90	34.60	54.00	19.40	Average	Horizontal
5	4874.00	36.60	4.90	41.50	74.00	32.50	Peak	Vertical
6	4874.00	26.20	4.90	31.10	54.00	22.90	Average	Vertical
7	7311.00	38.20	6.50	44.70	74.00	29.30	Peak	Vertical
8	7311.00	27.20	6.50	33.70	54.00	20.30	Average	Vertical

IEEE 802.11g_Highest Channel-1:

No.	Frequency (MHz)	Reading (dBuV/m)	Correction factor (dB)	Result (dBuV/m)	Limit (dBuV/m)	Margin (dB)	Detector	Antenna Polaxis
1	4924.00	37.60	4.00	41.60	74.00	32.40	Peak	Horizontal
2	4924.00	26.10	4.00	30.10	54.00	23.90	Average	Horizontal
3	7386.00	38.50	7.10	45.60	74.00	28.40	Peak	Horizontal
4	7386.00	27.30	7.10	34.40	54.00	19.60	Average	Horizontal
5	4924.00	36.80	5.00	41.80	74.00	32.20	Peak	Vertical
6	4924.00	26.10	5.00	31.10	54.00	22.90	Average	Vertical
7	7386.00	40.20	6.60	46.80	74.00	27.20	Peak	Vertical
8	7386.00	27.70	6.60	34.30	54.00	19.70	Average	Vertical

TEST REPORT

IEEE 802.11g_Highest Channel-2:

No.	Frequency (MHz)	Reading (dBuV/m)	Correction factor (dB)	Result (dBuV/m)	Limit (dBuV/m)	Margin (dB)	Detector	Antenna Polaxis
1	4934.00	37.80	4.10	41.90	74.00	32.10	Peak	Horizontal
2	4934.00	27.20	4.10	31.30	54.00	22.70	Average	Horizontal
3	7401.00	40.40	7.10	47.50	74.00	26.50	Peak	Horizontal
4	7401.00	29.00	7.10	36.10	54.00	17.90	Average	Horizontal
5	4934.00	38.60	5.10	43.70	74.00	30.30	Peak	Vertical
6	4934.00	28.40	5.10	33.50	54.00	20.50	Average	Vertical
7	7401.00	40.30	6.60	46.90	74.00	27.10	Peak	Vertical
8	7401.00	28.90	6.60	35.50	54.00	18.50	Average	Vertical

IEEE 802.11g_Highest Channel-3:

No.	Frequency (MHz)	Reading (dBuV/m)	Correction factor (dB)	Result (dBuV/m)	Limit (dBuV/m)	Margin (dB)	Detector	Antenna Polaxis
1	4944.00	36.80	4.10	40.90	74.00	33.10	Peak	Horizontal
2	4944.00	27.00	4.10	31.10	54.00	22.90	Average	Horizontal
3	7416.00	41.20	7.10	48.30	74.00	25.70	Peak	Horizontal
4	7416.00	28.90	7.10	36.00	54.00	18.00	Average	Horizontal
5	4944.00	38.60	5.10	43.70	74.00	30.30	Peak	Vertical
6	4944.00	27.80	5.10	32.90	54.00	21.10	Average	Vertical
7	7416.00	40.10	6.60	46.70	74.00	27.30	Peak	Vertical
8	7416.00	28.60	6.60	35.20	54.00	18.80	Average	Vertical

TEST REPORT

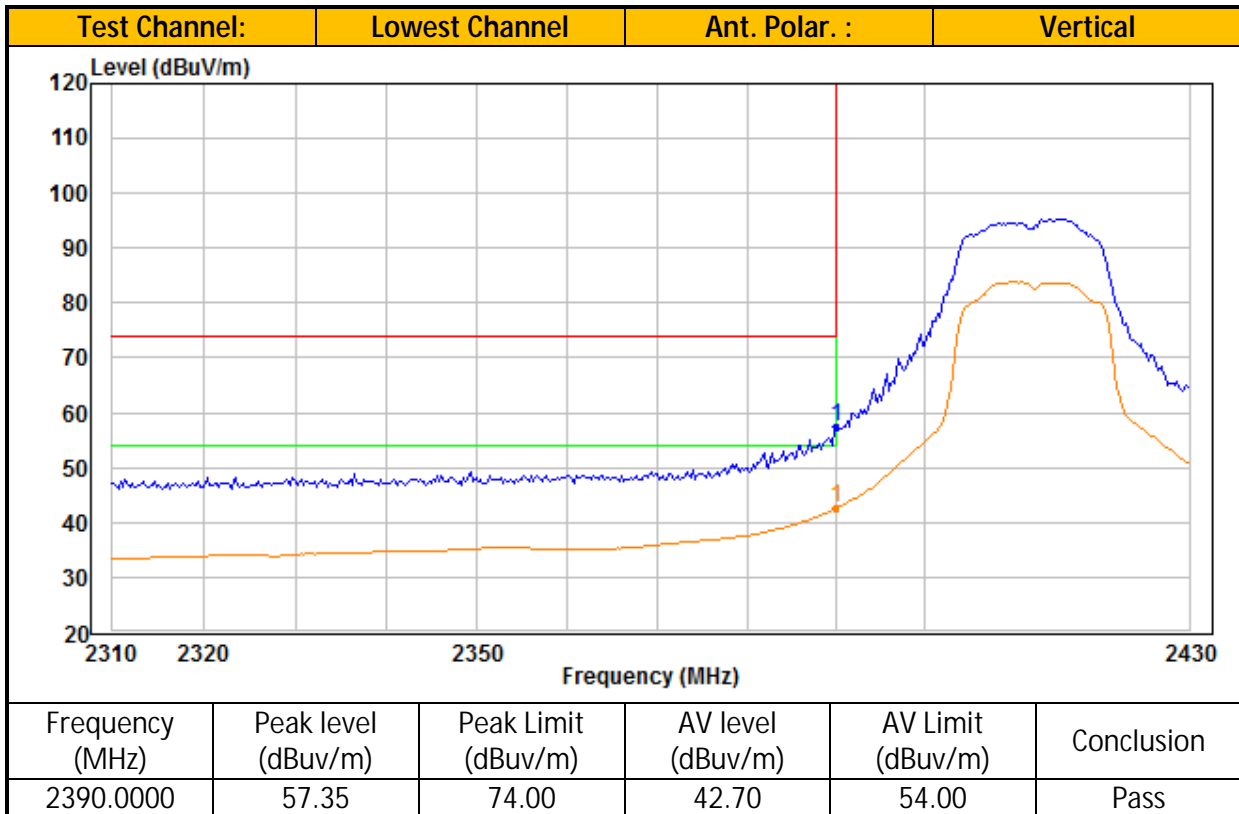
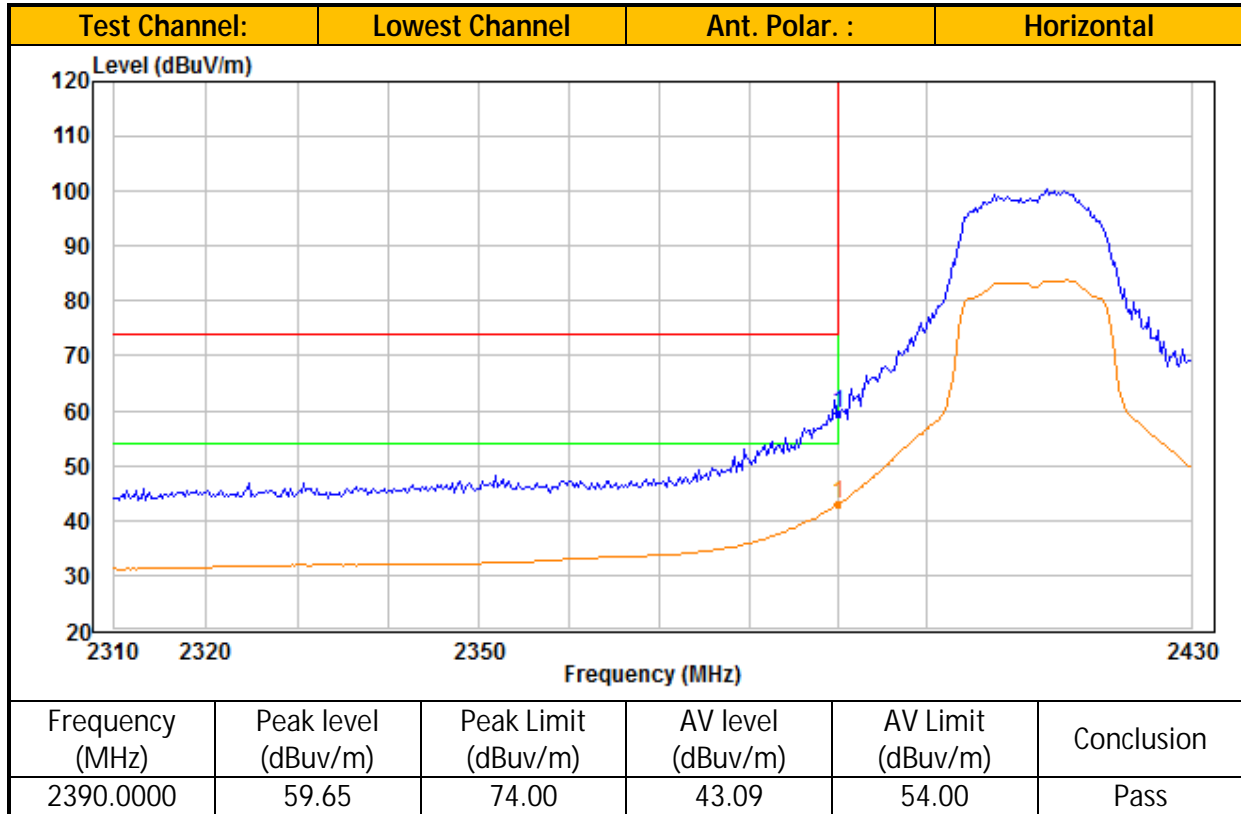

TEST REPORT

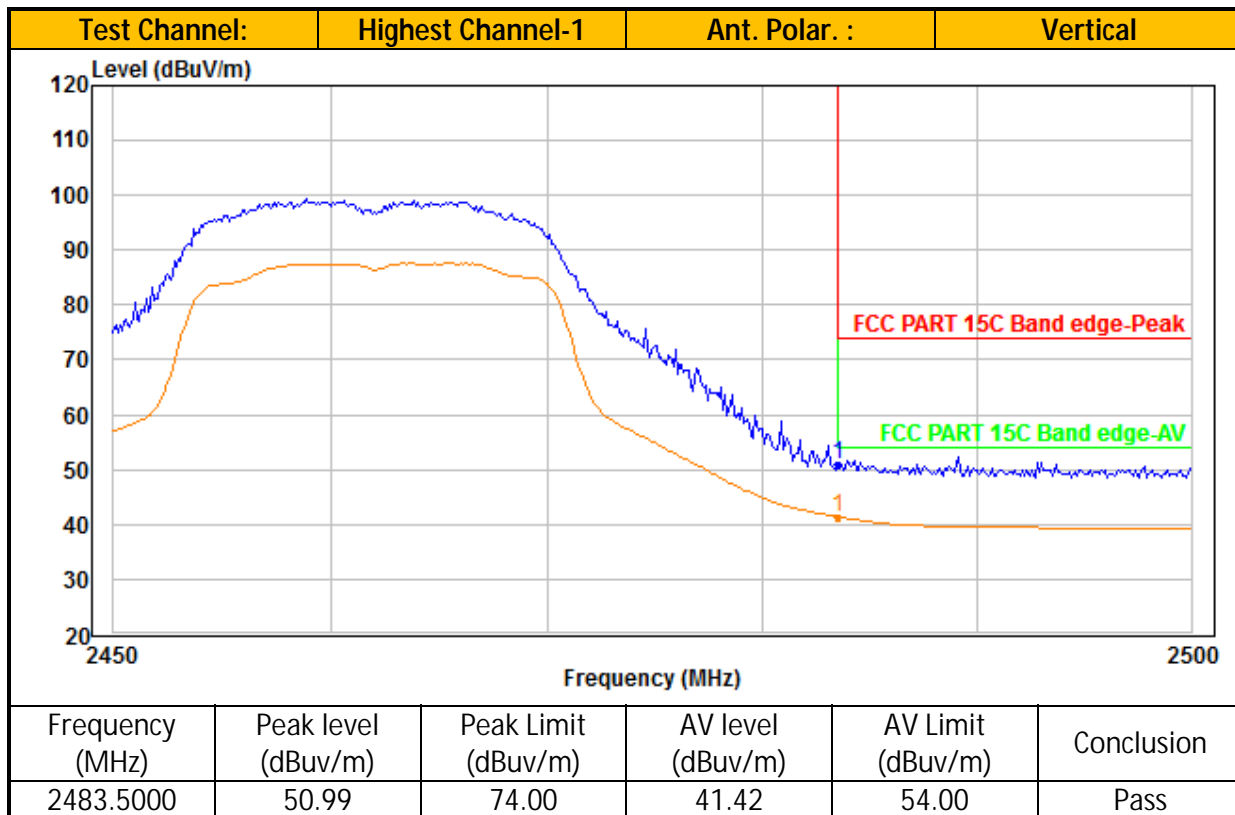
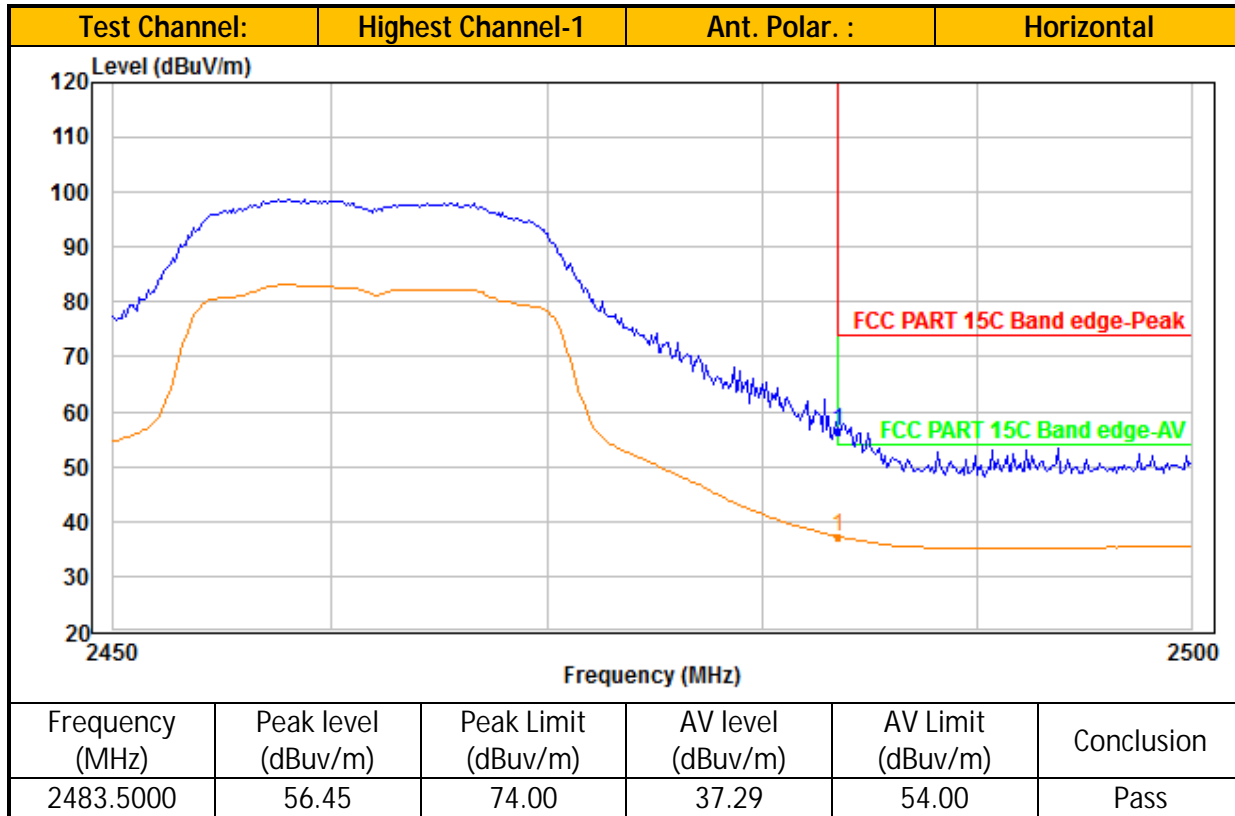

TEST REPORT

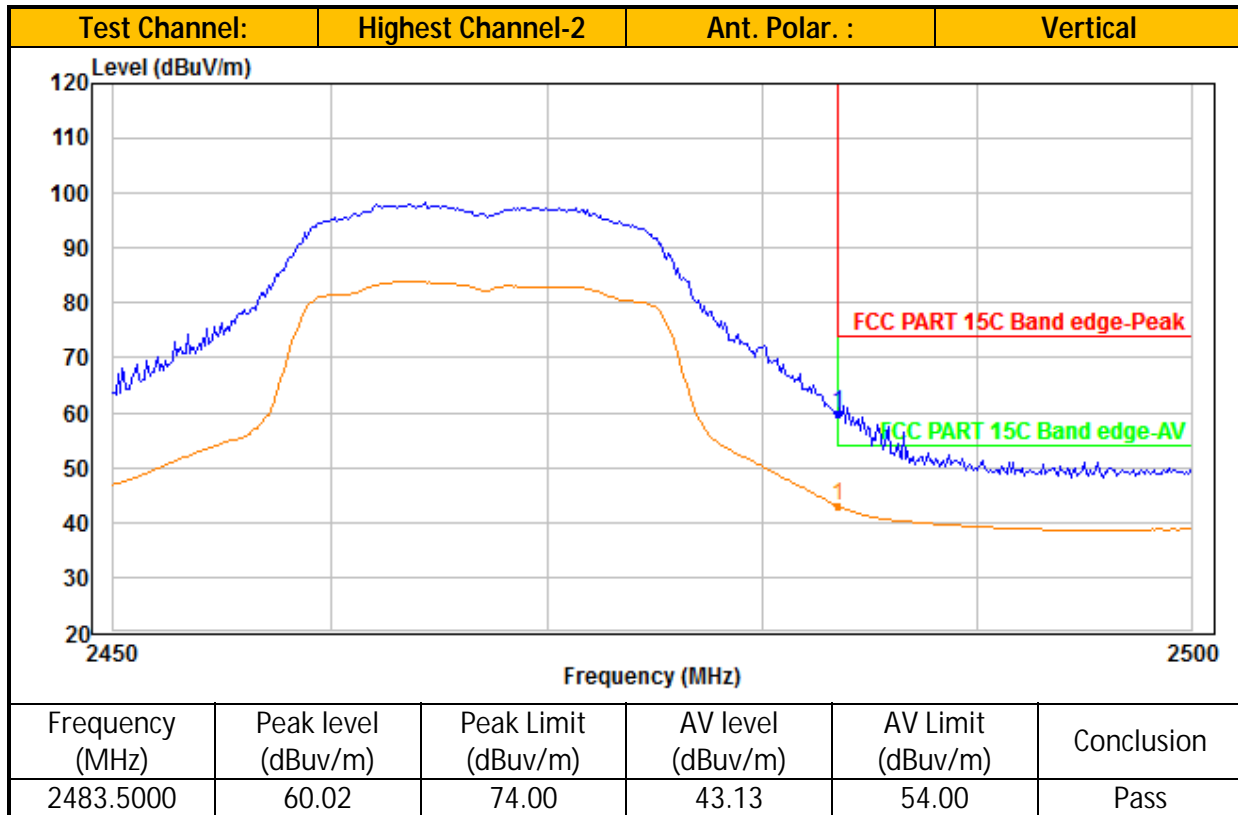
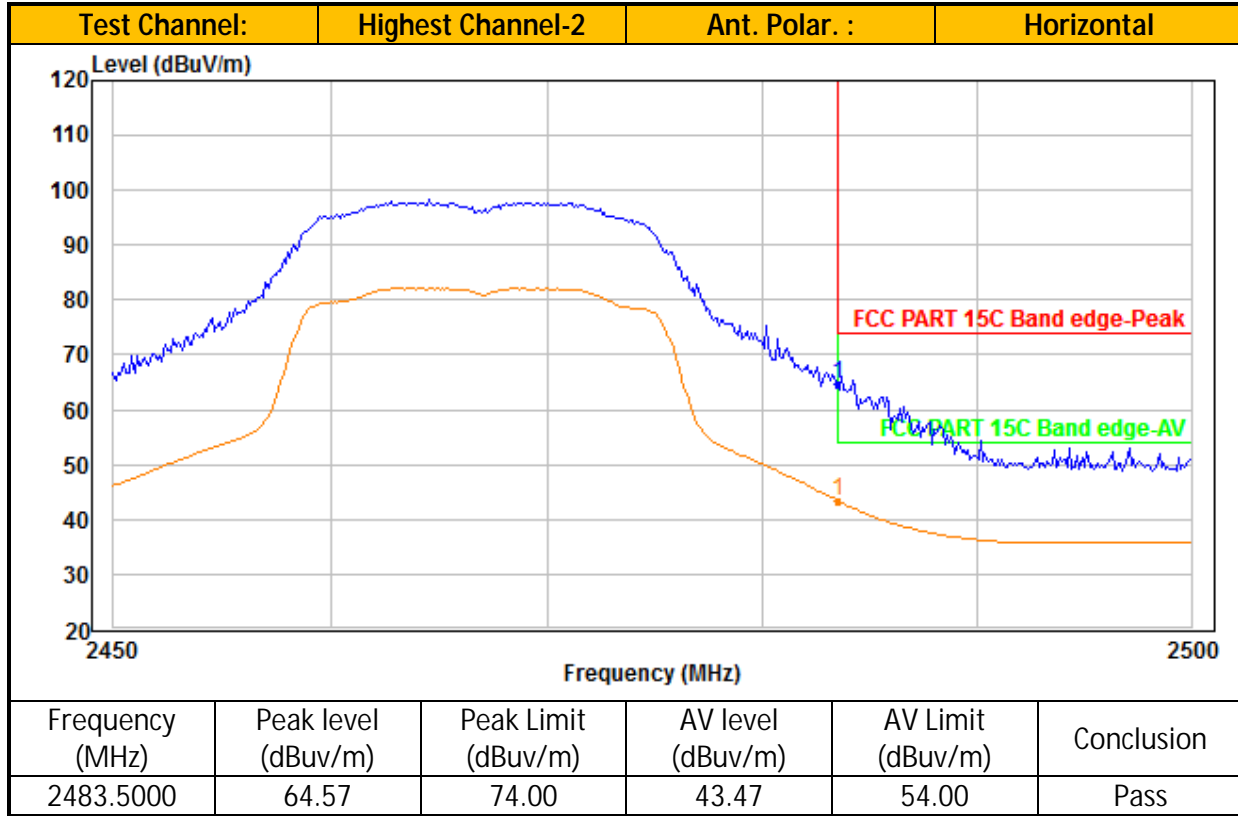

TEST REPORT

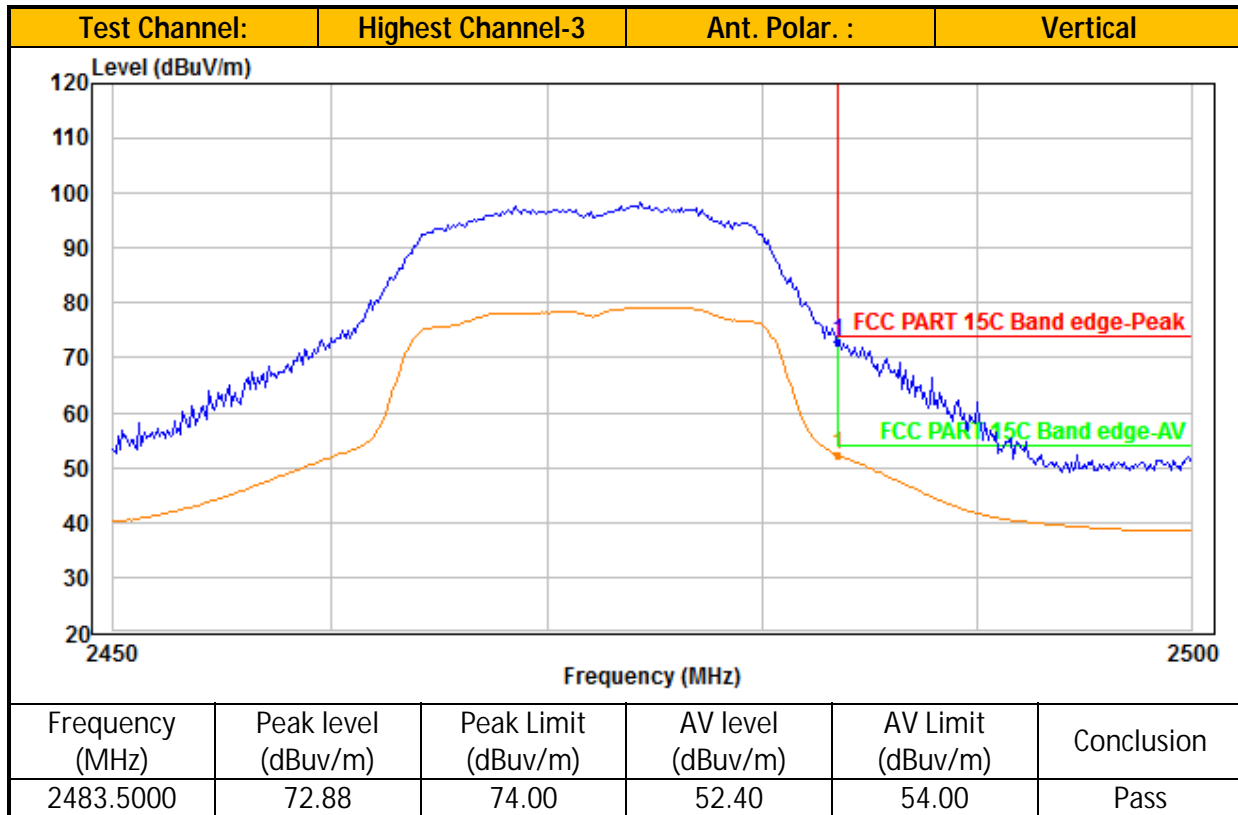
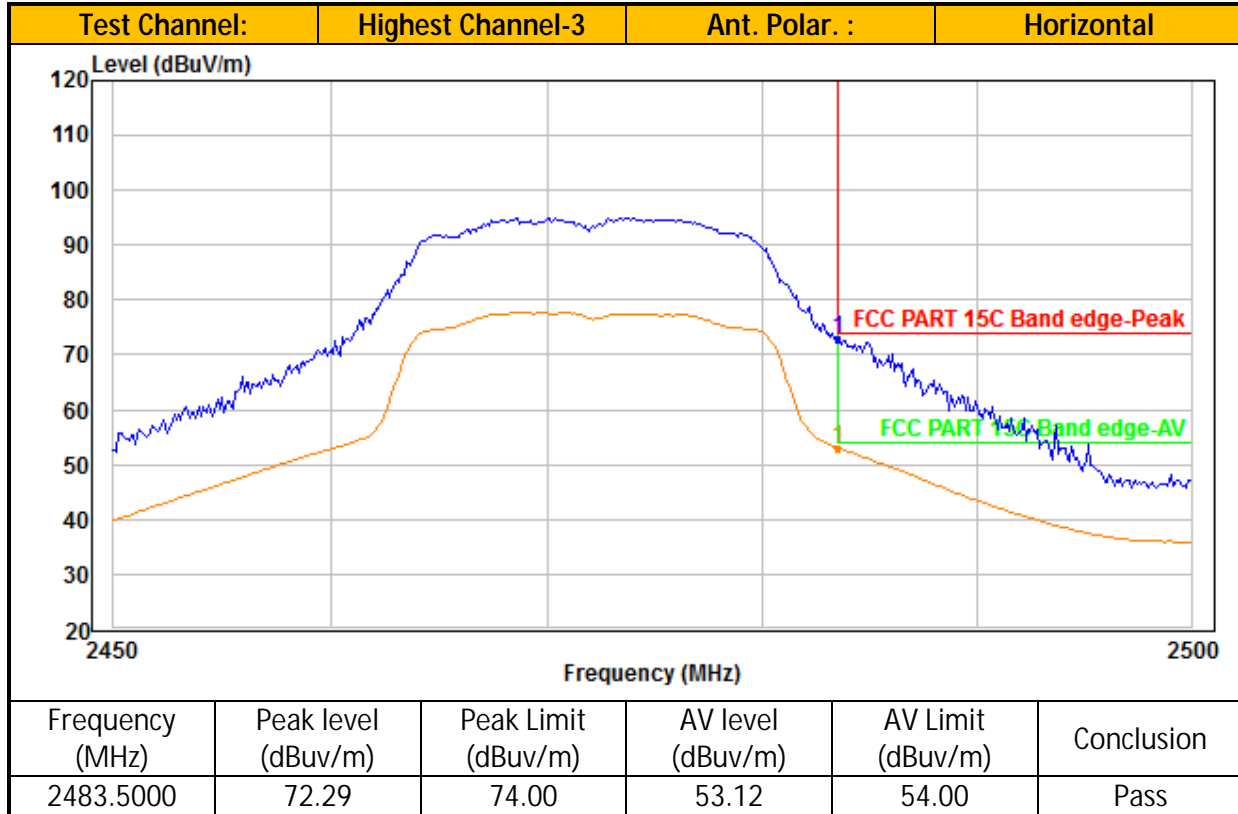

TEST REPORT

Ant. 2_Table 2
IEEE 802.11g (OFDM, 6 Mbps)

Radiated Emission Test Data (Above 1GHz):								
IEEE 802.11g_Lowest Channel:								
No.	Frequency (MHz)	Reading (dBuV/m)	Correction factor (dB)	Result (dBuV/m)	Limit (dBuV/m)	Margin (dB)	Detector	Antenna Polaxis
1	4824.00	36.90	3.90	40.80	74.00	33.20	Peak	Horizontal
2	4824.00	25.30	3.90	29.20	54.00	24.80	Average	Horizontal
3	7236.00	39.00	6.80	45.80	74.00	28.20	Peak	Horizontal
4	7236.00	27.90	6.80	34.70	54.00	19.30	Average	Horizontal
5	4824.00	38.10	4.90	43.00	74.00	31.00	Peak	Vertical
6	4824.00	27.20	4.90	32.10	54.00	21.90	Average	Vertical
7	7236.00	39.60	6.30	45.90	74.00	28.10	Peak	Vertical
8	7236.00	27.90	6.30	34.20	54.00	19.80	Average	Vertical

IEEE 802.11g_Middle Channel:								
No.	Frequency (MHz)	Reading (dBuV/m)	Correction factor (dB)	Result (dBuV/m)	Limit (dBuV/m)	Margin (dB)	Detector	Antenna Polaxis
1	4874.00	36.70	3.90	40.60	74.00	33.40	Peak	Horizontal
2	4874.00	26.20	3.90	30.10	54.00	23.90	Average	Horizontal
3	7311.00	39.20	6.90	46.10	74.00	27.90	Peak	Horizontal
4	7311.00	28.20	6.90	35.10	54.00	18.90	Average	Horizontal
5	4874.00	39.60	4.90	44.50	74.00	29.50	Peak	Vertical
6	4874.00	29.20	4.90	34.10	54.00	19.90	Average	Vertical
7	7311.00	39.90	6.50	46.40	74.00	27.60	Peak	Vertical
8	7311.00	28.20	6.50	34.70	54.00	19.30	Average	Vertical

IEEE 802.11g_Highest Channel-1:								
No.	Frequency (MHz)	Reading (dBuV/m)	Correction factor (dB)	Result (dBuV/m)	Limit (dBuV/m)	Margin (dB)	Detector	Antenna Polaxis
1	4924.00	42.30	4.00	46.30	74.00	27.70	Peak	Horizontal
2	4924.00	26.70	4.00	30.70	54.00	23.30	Average	Horizontal
3	7386.00	40.10	7.10	47.20	74.00	26.80	Peak	Horizontal
4	7386.00	28.40	7.10	35.50	54.00	18.50	Average	Horizontal
5	4924.00	42.00	5.00	47.00	74.00	27.00	Peak	Vertical
6	4924.00	29.50	5.00	34.50	54.00	19.50	Average	Vertical
7	7386.00	39.20	6.60	45.80	74.00	28.20	Peak	Vertical
8	7386.00	28.30	6.60	34.90	54.00	19.10	Average	Vertical

TEST REPORT

IEEE 802.11g_Highest Channel-2:

No.	Frequency (MHz)	Reading (dBuV/m)	Correction factor (dB)	Result (dBuV/m)	Limit (dBuV/m)	Margin (dB)	Detector	Antenna Polaxis
1	4934.00	39.20	4.10	43.30	74.00	30.70	Peak	Horizontal
2	4934.00	28.70	4.10	32.80	54.00	21.20	Average	Horizontal
3	7401.00	40.70	7.10	47.80	74.00	26.20	Peak	Horizontal
4	7401.00	29.30	7.10	36.40	54.00	17.60	Average	Horizontal
5	4934.00	39.80	5.10	44.90	74.00	29.10	Peak	Vertical
6	4934.00	28.60	5.10	33.70	54.00	20.30	Average	Vertical
7	7401.00	40.20	6.60	46.80	74.00	27.20	Peak	Vertical
8	7401.00	28.90	6.60	35.50	54.00	18.50	Average	Vertical

IEEE 802.11g_Highest Channel-3:

No.	Frequency (MHz)	Reading (dBuV/m)	Correction factor (dB)	Result (dBuV/m)	Limit (dBuV/m)	Margin (dB)	Detector	Antenna Polaxis
1	4944.00	40.40	4.10	44.50	74.00	29.50	Peak	Horizontal
2	4944.00	28.70	4.10	32.80	54.00	21.20	Average	Horizontal
3	7416.00	41.30	7.10	48.40	74.00	25.60	Peak	Horizontal
4	7416.00	29.30	7.10	36.40	54.00	17.60	Average	Horizontal
5	4944.00	39.90	5.10	45.00	74.00	29.00	Peak	Vertical
6	4944.00	28.80	5.10	33.90	54.00	20.10	Average	Vertical
7	7416.00	40.20	6.60	46.80	74.00	27.20	Peak	Vertical
8	7416.00	29.00	6.60	35.60	54.00	18.40	Average	Vertical

TEST REPORT

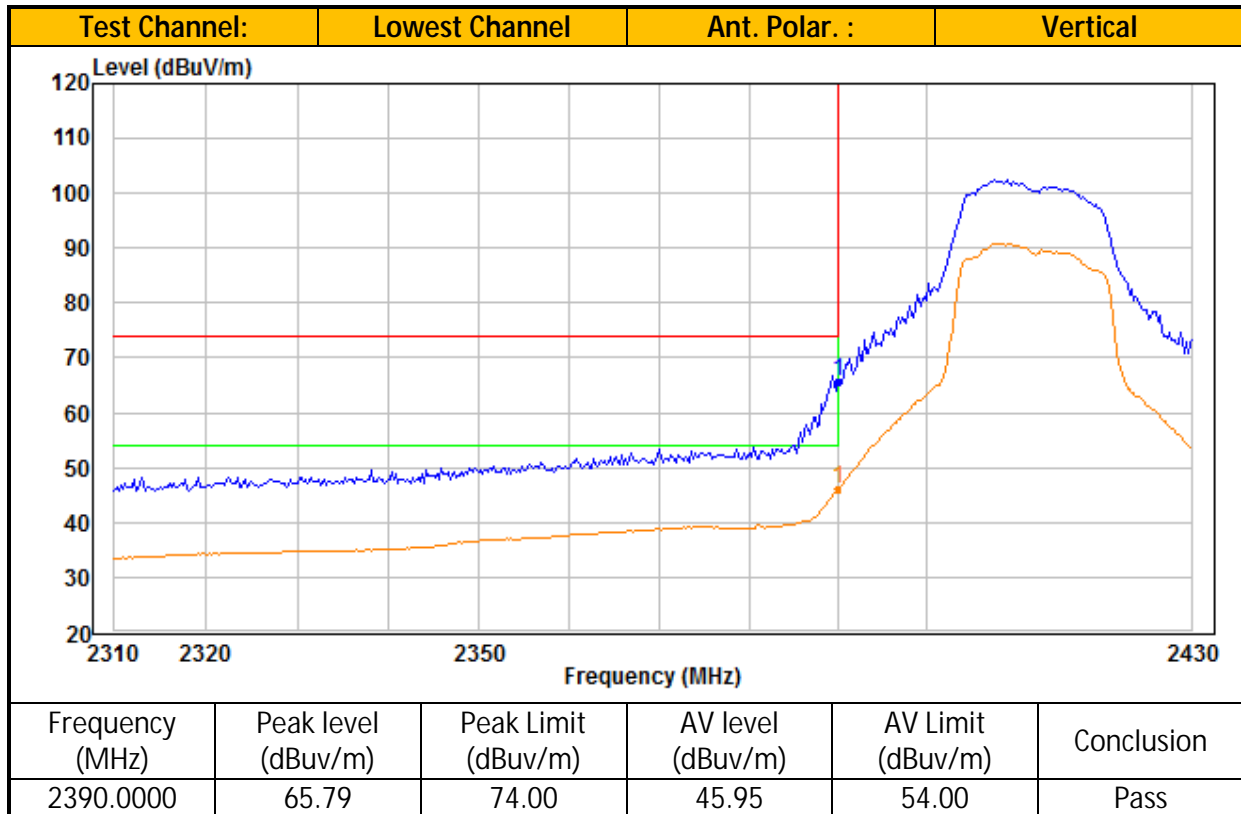
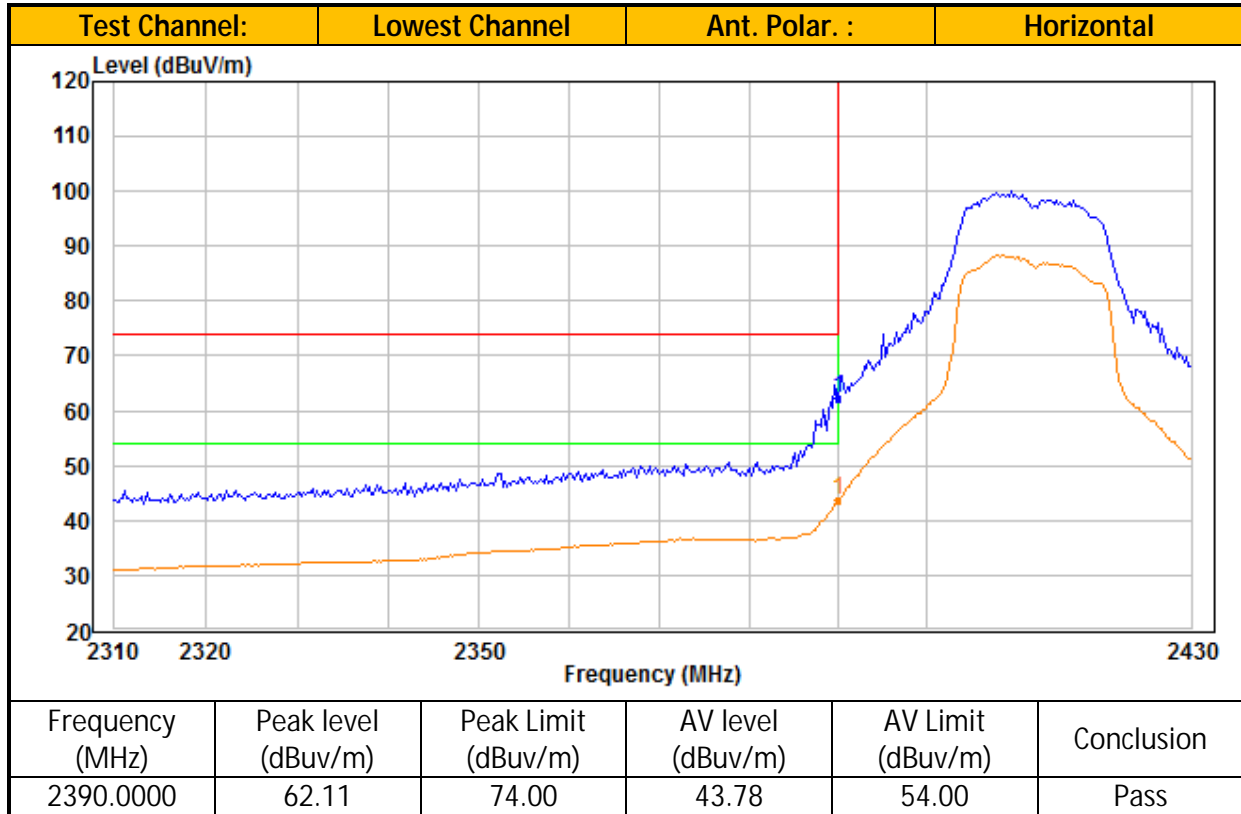

TEST REPORT

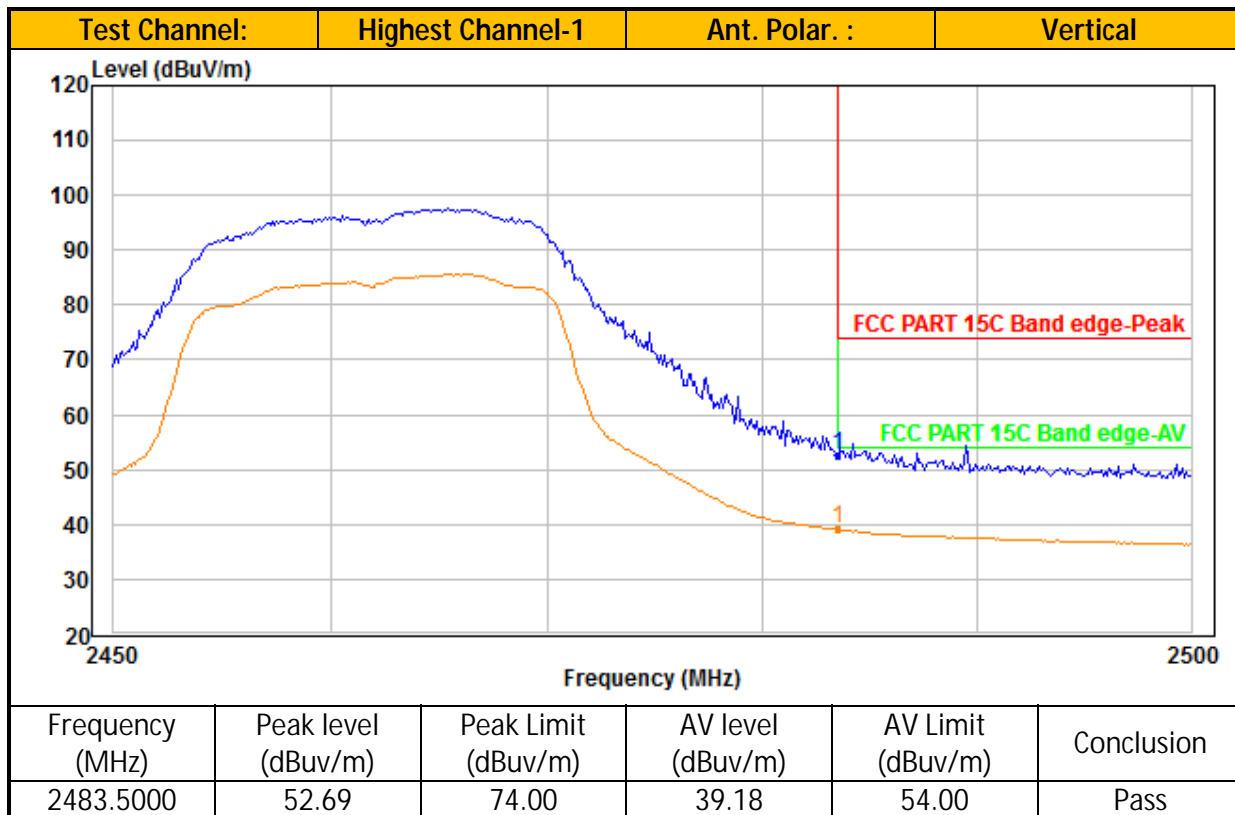
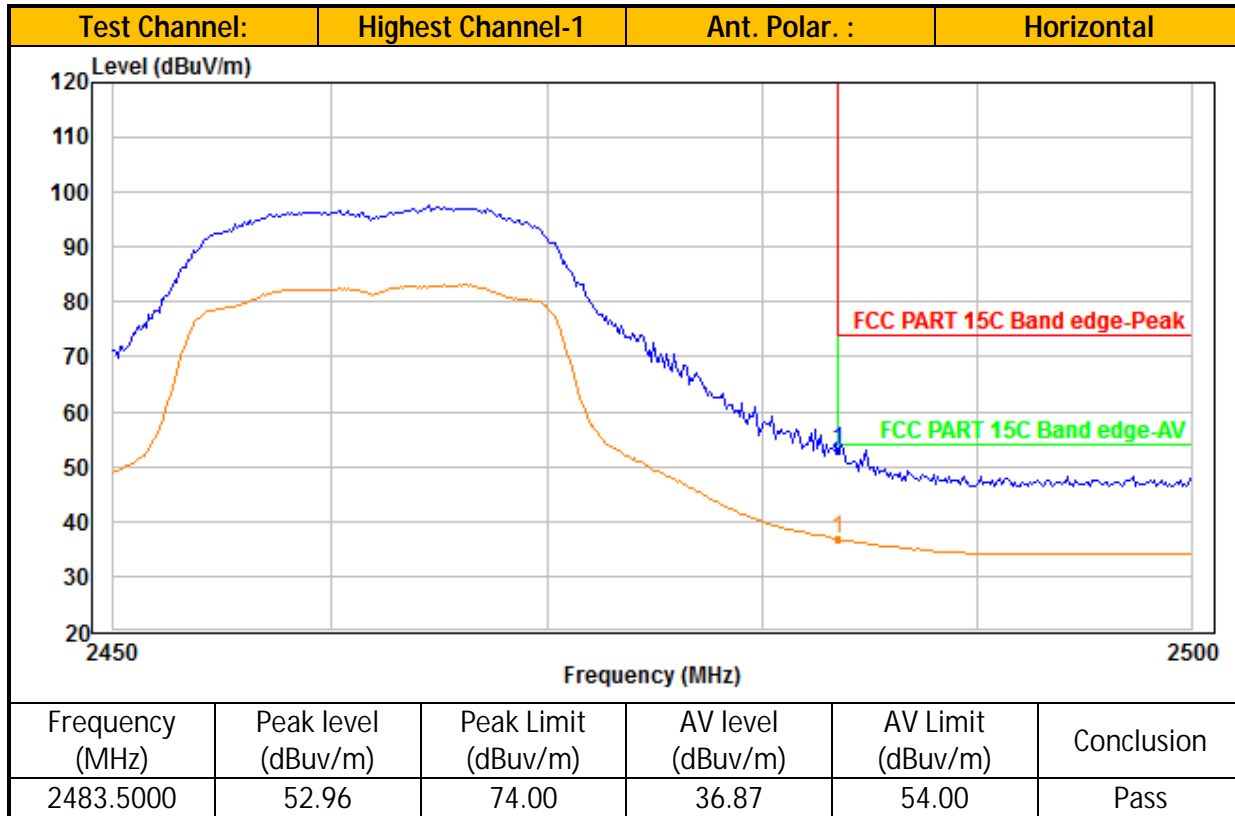

TEST REPORT

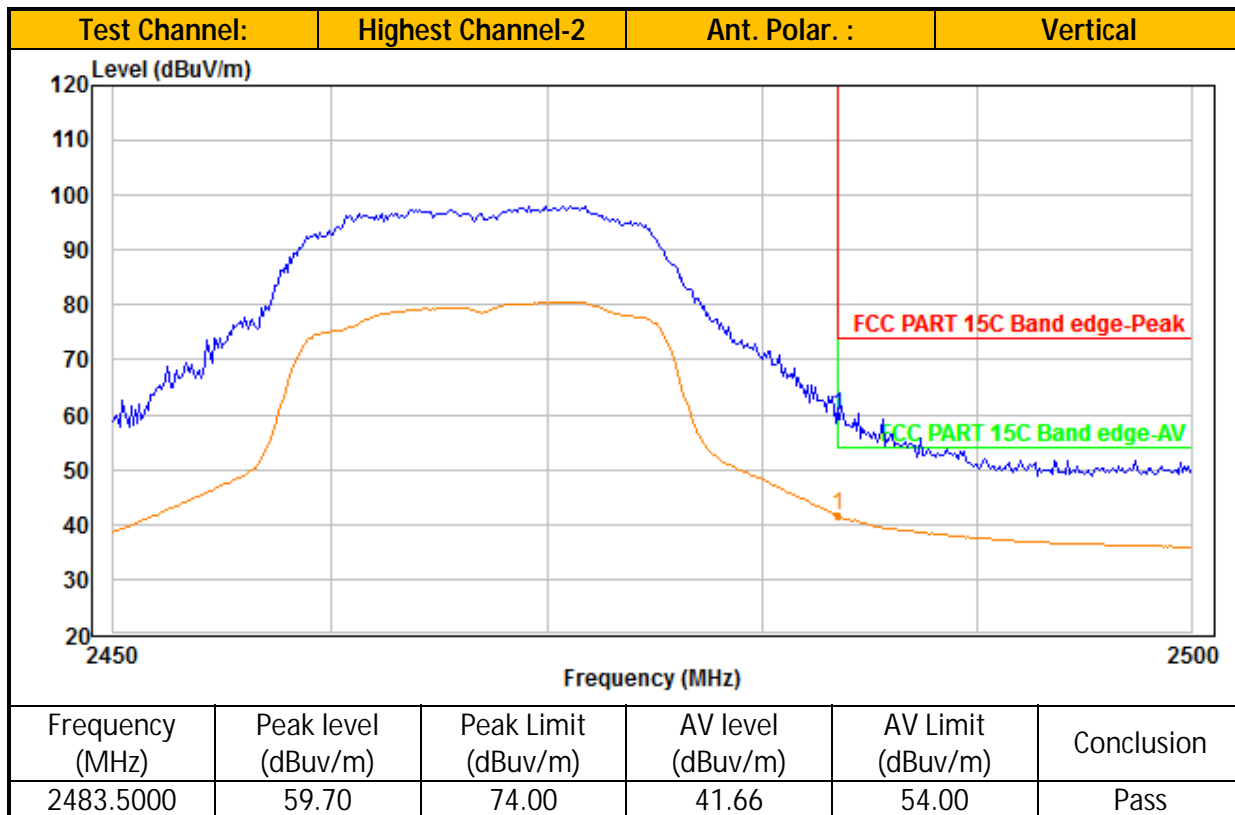
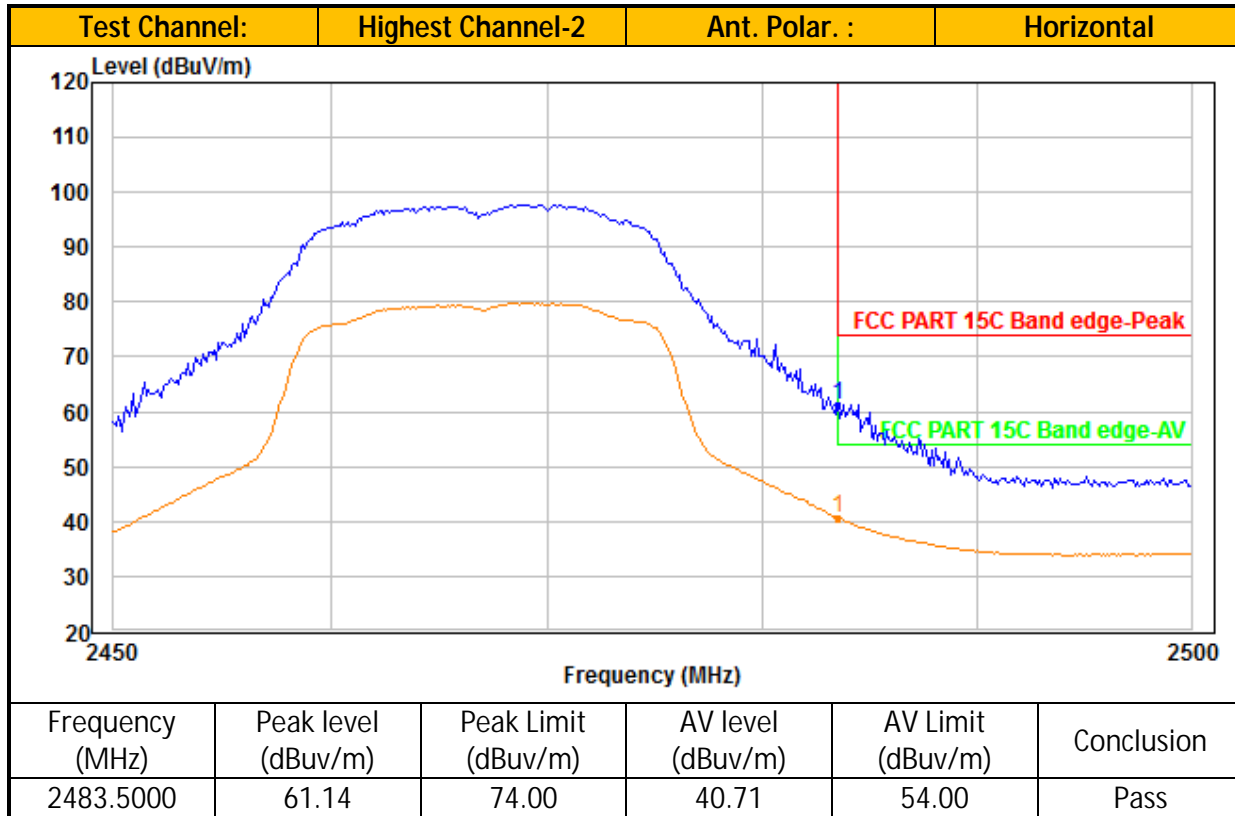

TEST REPORT

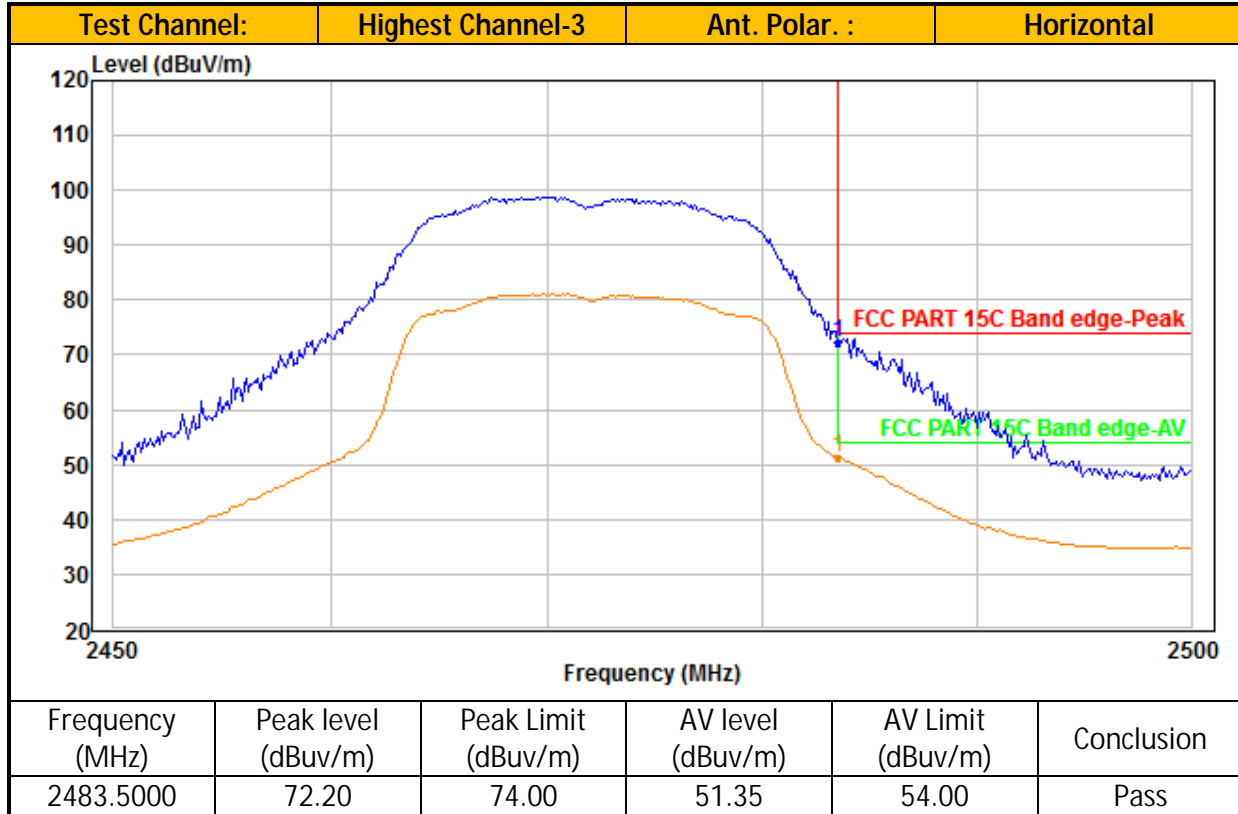

TEST REPORT

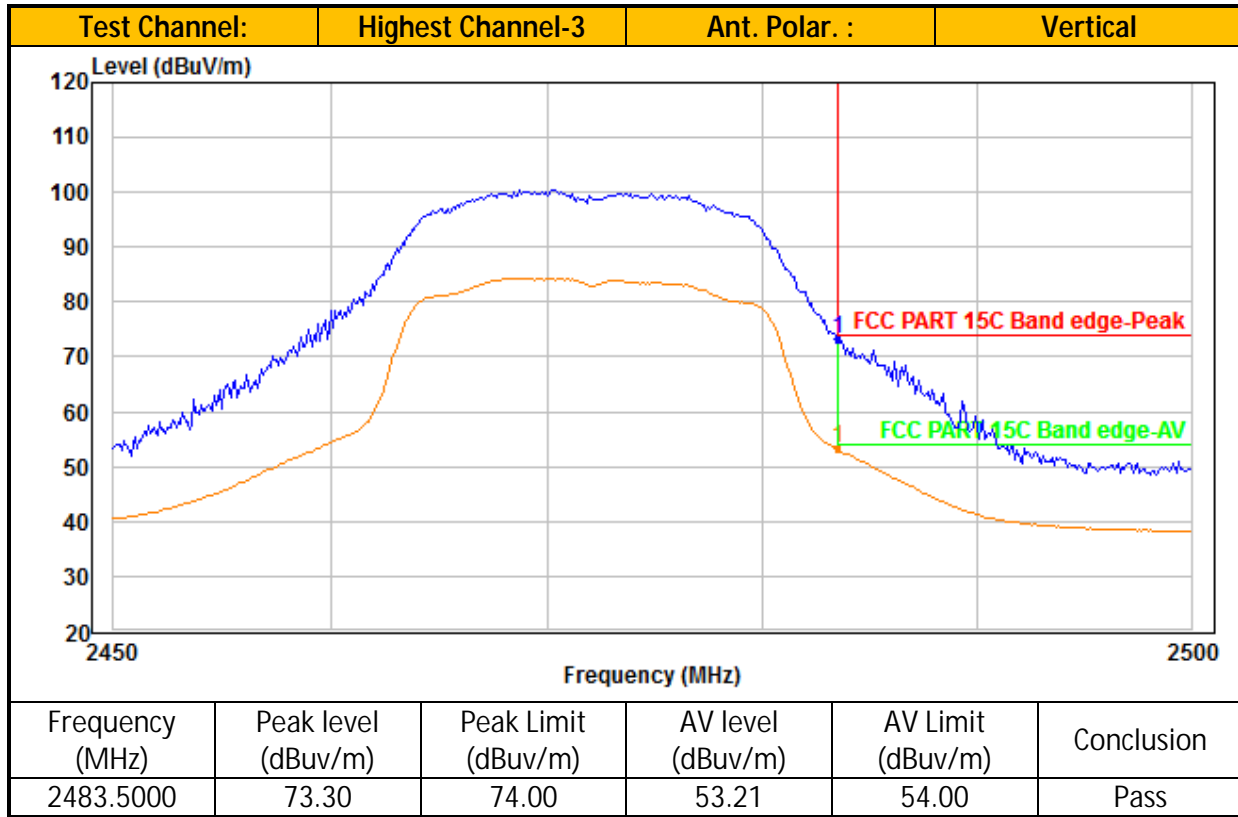

- NOTES:
1. Peak detector is used for the emission measurement.
 2. Average detector is used for the average data of emission measurement
 3. All measurements were made at 3 meters. Radiated emissions not detected at the 3-meter distance were measured at 0.3-meter and an inverse proportional extrapolation was performed to compare the signal level to the 3-meter limit. No other radiated emissions than those reported were detected at a test distance of 0.3-meter.
 4. Value in the margin column shows emission below limit.
 5. Horn antenna is used for the emission over 1000MHz.
 6. Emission (the row indicated by ***bold italic***) within the restricted band meets the requirement of FCC Part 15 Section 15.205.
 7. For the measurement of radiated emission, summation method was used which numerical integrating (in terms of linear power) over the transmitter occupied bandwidth.
 8. For the linear power measurement, data in 1MHz spacing was collected by spectrum analyzer with 1MHz resolution bandwidth.

TEST REPORT

Ant. 1_Table 3
IEEE 802.11n (20MHz) (OFDM, MCS0)

Radiated Emission Test Data (Above 1GHz):

IEEE 802.11n20_Lowest Channel:

No.	Frequency (MHz)	Reading (dBuV/m)	Correction factor (dB)	Result (dBuV/m)	Limit (dBuV/m)	Margin (dB)	Detector	Antenna Polaxis
1	4824.00	33.90	3.90	37.80	74.00	36.20	Peak	Horizontal
2	4824.00	22.90	3.90	26.80	54.00	27.20	Average	Horizontal
3	7236.00	36.80	7.10	43.90	74.00	30.10	Peak	Horizontal
4	7236.00	25.20	7.10	32.30	54.00	21.70	Average	Horizontal
5	4824.00	35.80	4.90	40.70	74.00	33.30	Peak	Vertical
6	4824.00	24.30	4.90	29.20	54.00	24.80	Average	Vertical
7	7236.00	37.80	6.30	44.10	74.00	29.90	Peak	Vertical
8	7236.00	26.60	6.30	32.90	54.00	21.10	Average	Vertical

IEEE 802.11n20_Middle Channel:

No.	Frequency (MHz)	Reading (dBuV/m)	Correction factor (dB)	Result (dBuV/m)	Limit (dBuV/m)	Margin (dB)	Detector	Antenna Polaxis
1	4874.00	38.70	3.90	42.60	74.00	31.40	Peak	Horizontal
2	4874.00	26.40	3.90	30.30	54.00	23.70	Average	Horizontal
3	7311.00	38.20	6.90	45.10	74.00	28.90	Peak	Horizontal
4	7311.00	27.20	6.90	34.10	54.00	19.90	Average	Horizontal
5	4874.00	36.70	4.90	41.60	74.00	32.40	Peak	Vertical
6	4874.00	25.30	4.90	30.20	54.00	23.80	Average	Vertical
7	7311.00	38.20	8.20	46.40	74.00	27.60	Peak	Vertical
8	7311.00	25.30	8.20	33.50	54.00	20.50	Average	Vertical

IEEE 802.11n20_Highest Channel-1:

No.	Frequency (MHz)	Reading (dBuV/m)	Correction factor (dB)	Result (dBuV/m)	Limit (dBuV/m)	Margin (dB)	Detector	Antenna Polaxis
1	4924.00	38.20	4.00	42.20	74.00	31.80	Peak	Horizontal
2	4924.00	24.80	4.00	28.80	54.00	25.20	Average	Horizontal
3	7386.00	37.80	7.10	44.90	74.00	29.10	Peak	Horizontal
4	7386.00	27.10	7.10	34.20	54.00	19.80	Average	Horizontal
5	4924.00	36.50	5.00	41.50	74.00	32.50	Peak	Vertical
6	4924.00	25.00	5.00	30.00	54.00	24.00	Average	Vertical
7	7386.00	38.20	6.60	44.80	74.00	29.20	Peak	Vertical
8	7386.00	27.20	6.60	33.80	54.00	20.20	Average	Vertical

TEST REPORT

IEEE 802.11n20_Highest Channel-2:

No.	Frequency (MHz)	Reading (dBuV/m)	Correction factor (dB)	Result (dBuV/m)	Limit (dBuV/m)	Margin (dB)	Detector	Antenna Polaxis
1	4934.00	36.30	4.10	40.40	74.00	33.60	Peak	Horizontal
2	4934.00	25.40	4.10	29.50	54.00	24.50	Average	Horizontal
3	7401.00	40.40	7.10	47.50	74.00	26.50	Peak	Horizontal
4	7401.00	28.90	7.10	36.00	54.00	18.00	Average	Horizontal
5	4934.00	39.90	5.10	45.00	74.00	29.00	Peak	Vertical
6	4934.00	28.00	5.10	33.10	54.00	20.90	Average	Vertical
7	7401.00	39.90	6.60	46.50	74.00	27.50	Peak	Vertical
8	7401.00	29.00	6.60	35.60	54.00	18.40	Average	Vertical

IEEE 802.11n20_Highest Channel-3:

No.	Frequency (MHz)	Reading (dBuV/m)	Correction factor (dB)	Result (dBuV/m)	Limit (dBuV/m)	Margin (dB)	Detector	Antenna Polaxis
1	4944.00	39.20	4.10	43.30	74.00	30.70	Peak	Horizontal
2	4944.00	28.20	4.10	32.30	54.00	21.70	Average	Horizontal
3	7416.00	40.30	7.10	47.40	74.00	26.60	Peak	Horizontal
4	7416.00	29.10	7.10	36.20	54.00	17.80	Average	Horizontal
5	4944.00	39.80	5.10	44.90	74.00	29.10	Peak	Vertical
6	4944.00	28.10	5.10	33.20	54.00	20.80	Average	Vertical
7	7416.00	41.20	6.60	47.80	74.00	26.20	Peak	Vertical
8	7416.00	28.80	6.60	35.40	54.00	18.60	Average	Vertical

TEST REPORT

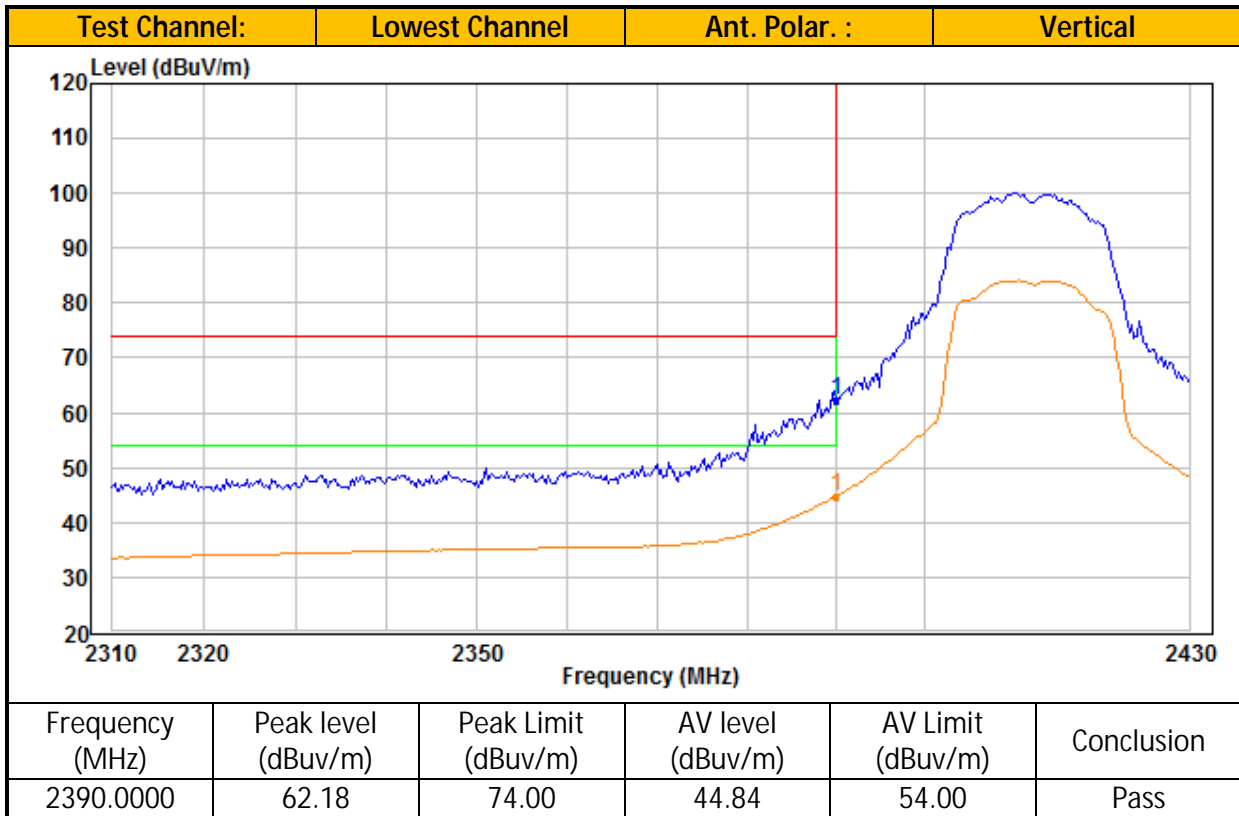
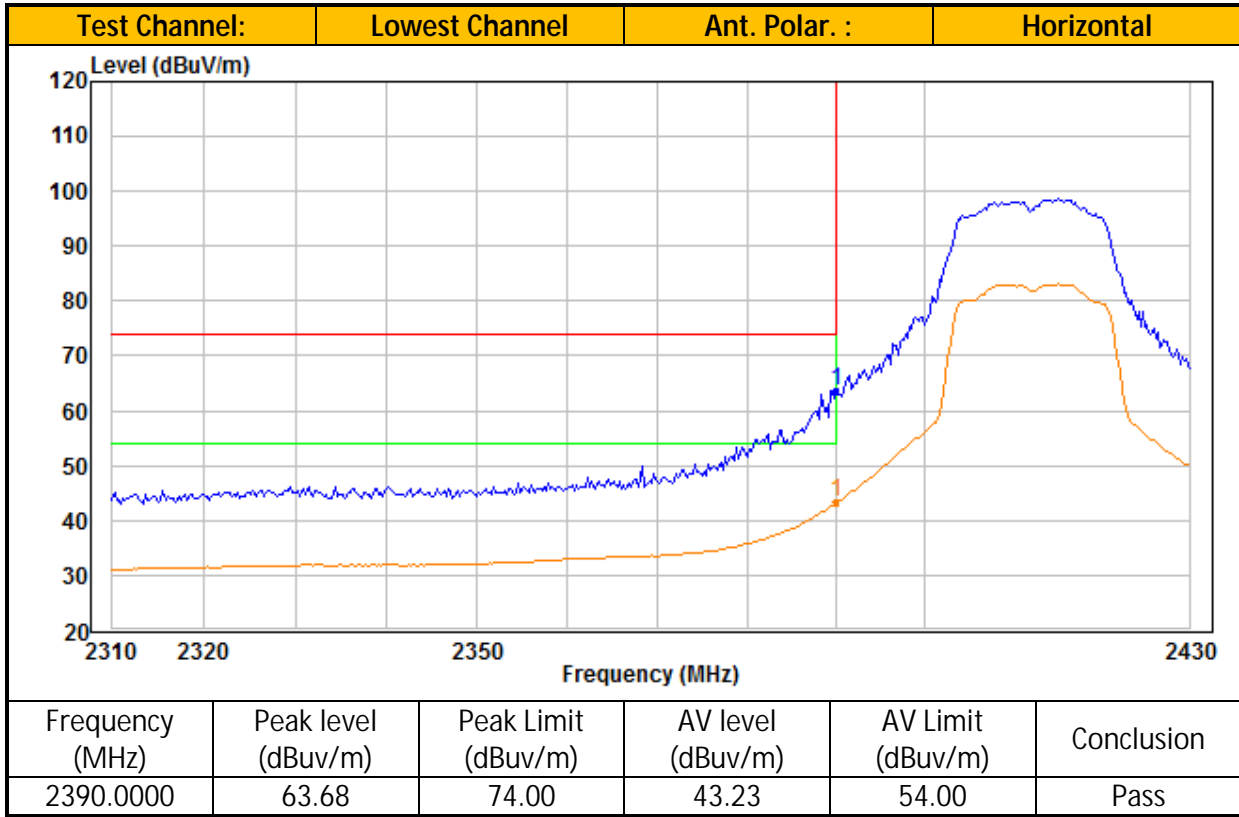

TEST REPORT

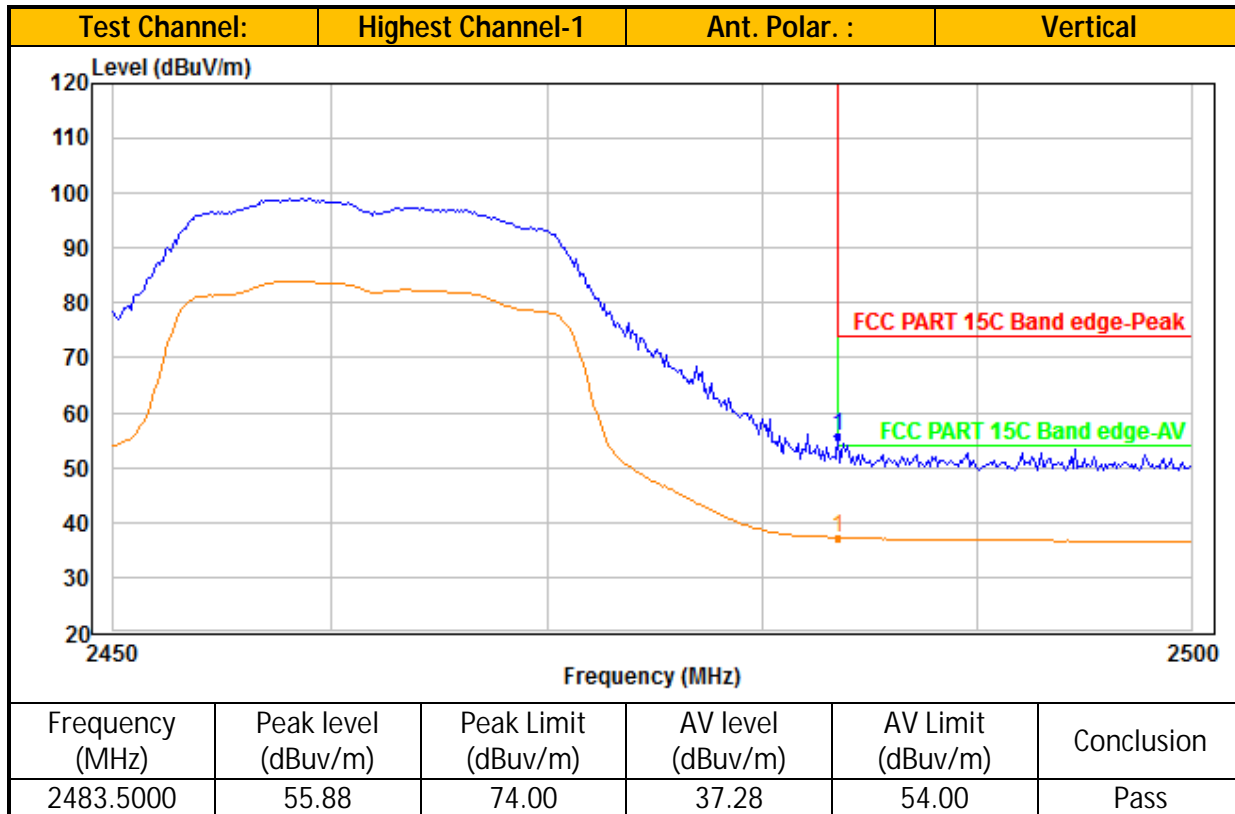
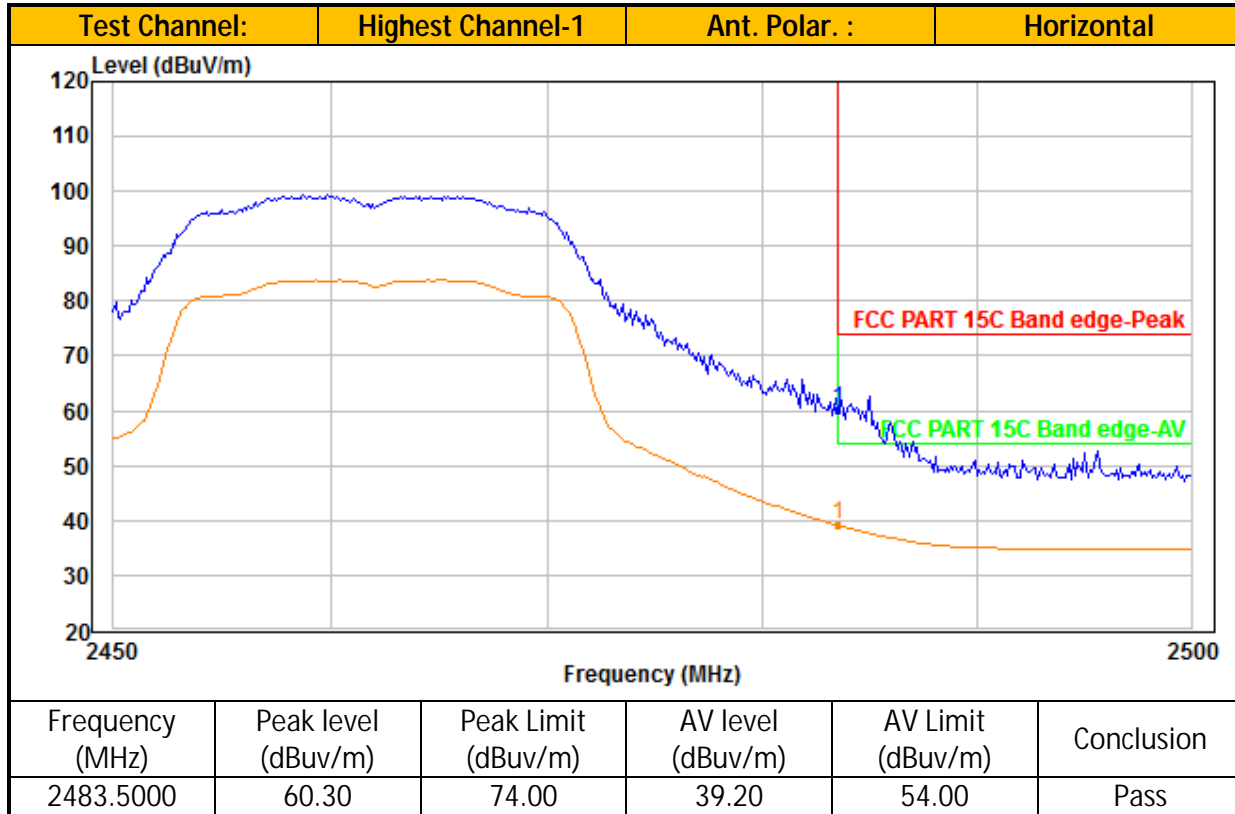

TEST REPORT

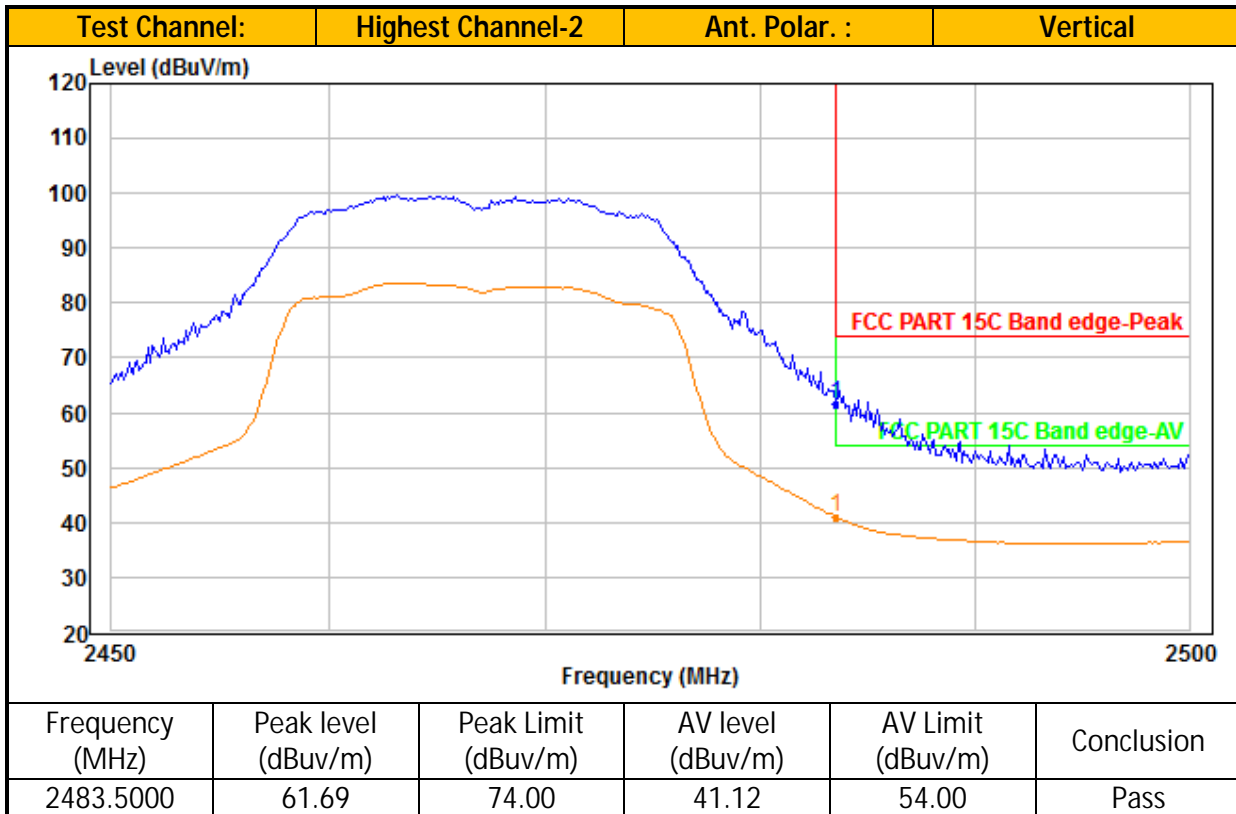
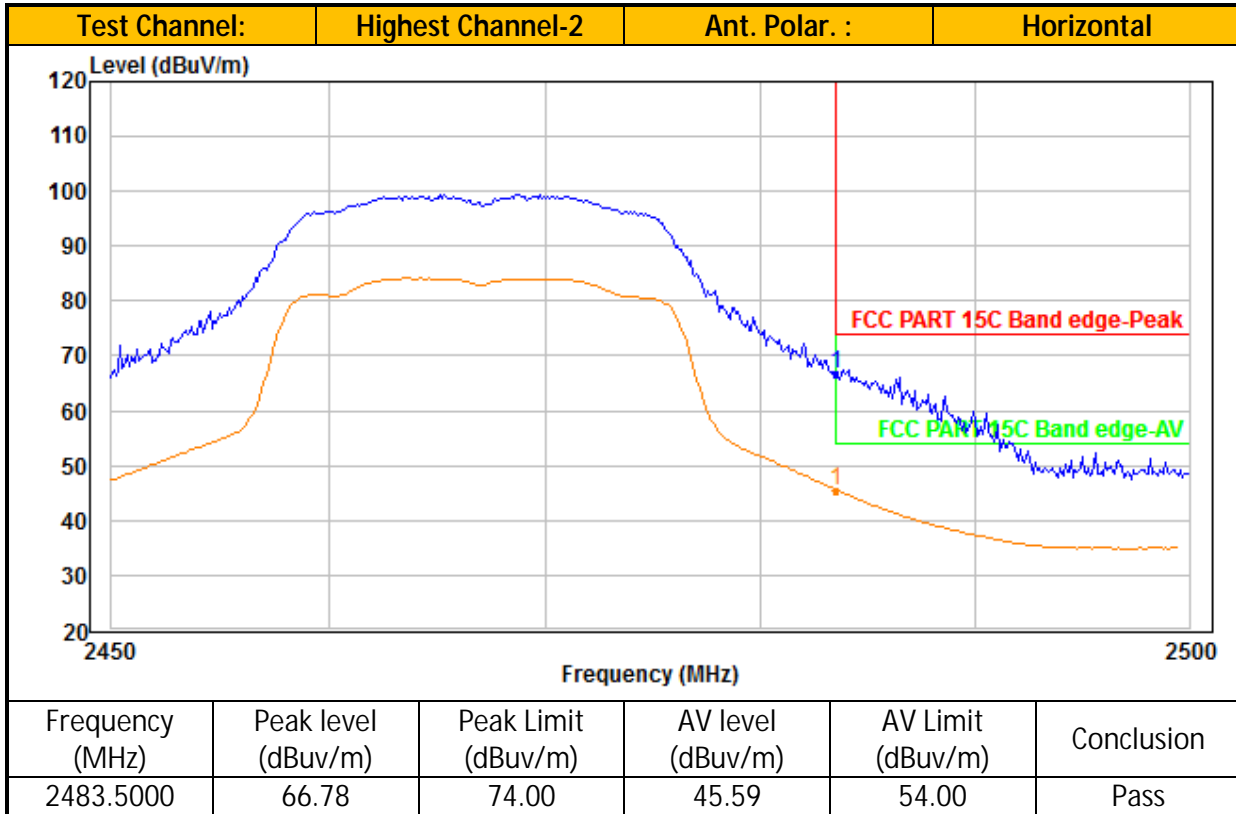

TEST REPORT

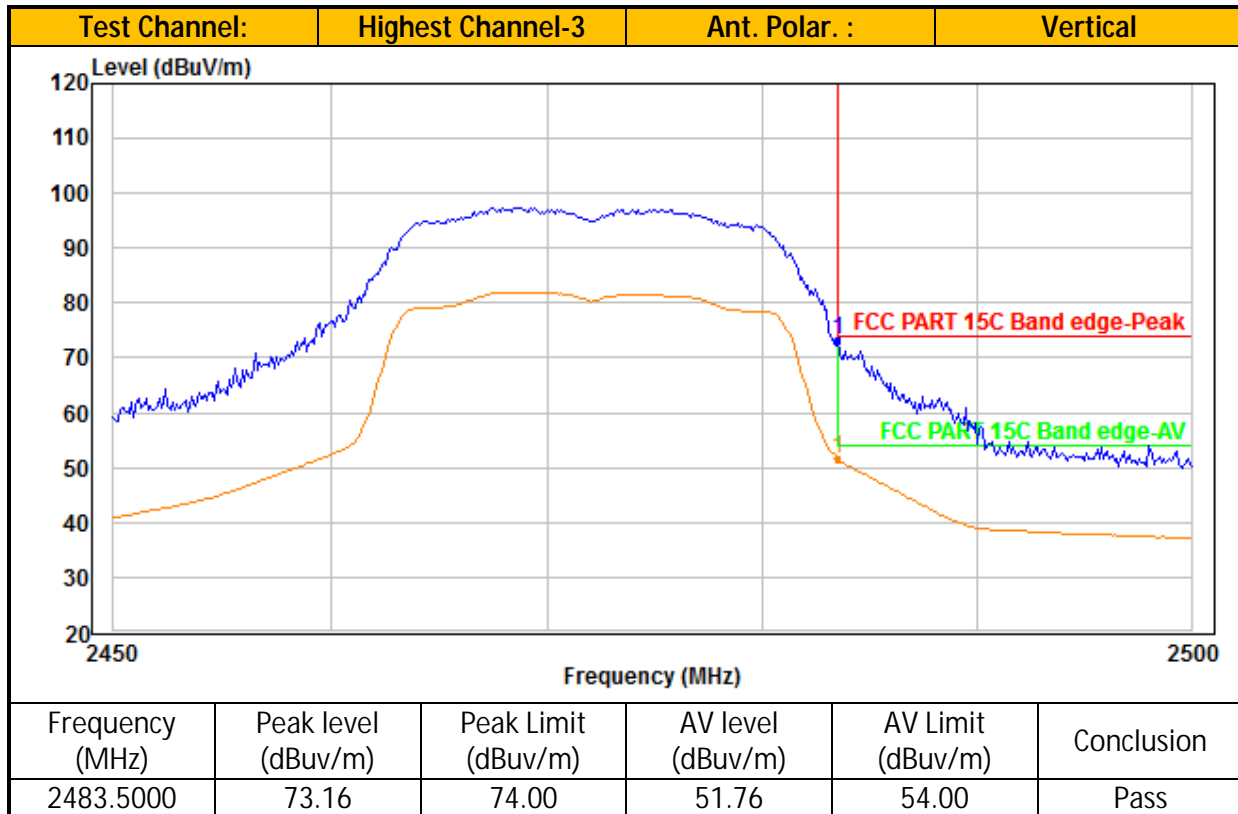
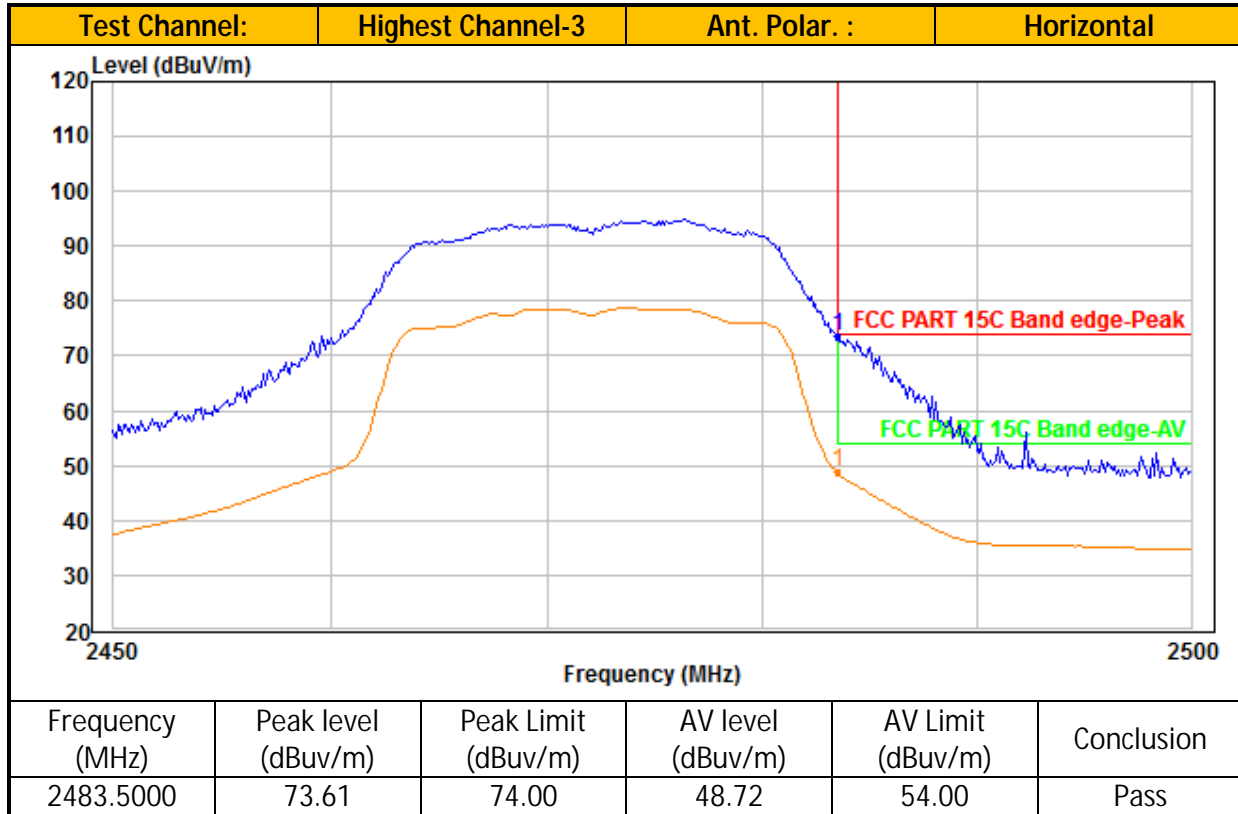

TEST REPORT

Ant. 2_Table 3
IEEE 802.11n (20MHz) (OFDM, MCS0)

Radiated Emission Test Data (Above 1GHz):
IEEE 802.11n20_Lowest Channel:

No.	Frequency (MHz)	Reading (dBuV/m)	Correction factor (dB)	Result (dBuV/m)	Limit (dBuV/m)	Margin (dB)	Detector	Antenna Polaxis
1	4824.00	36.60	3.90	40.50	74.00	33.50	Peak	Horizontal
2	4824.00	25.70	3.90	29.60	54.00	24.40	Average	Horizontal
3	7236.00	40.60	6.80	47.40	74.00	26.60	Peak	Horizontal
4	7236.00	28.30	6.80	35.10	54.00	18.90	Average	Horizontal
5	4824.00	39.50	4.90	44.40	74.00	29.60	Peak	Vertical
6	4824.00	28.30	4.90	33.20	54.00	20.80	Average	Vertical
7	7236.00	40.30	6.30	46.60	74.00	27.40	Peak	Vertical
8	7236.00	28.30	6.30	34.60	54.00	19.40	Average	Vertical

IEEE 802.11n20_Middle Channel:

No.	Frequency (MHz)	Reading (dBuV/m)	Correction factor (dB)	Result (dBuV/m)	Limit (dBuV/m)	Margin (dB)	Detector	Antenna Polaxis
1	4874.00	37.90	3.90	41.80	74.00	32.20	Peak	Horizontal
2	4874.00	26.90	3.90	30.80	54.00	23.20	Average	Horizontal
3	7311.00	40.60	6.90	47.50	74.00	26.50	Peak	Horizontal
4	7311.00	28.80	6.90	35.70	54.00	18.30	Average	Horizontal
5	4874.00	40.20	4.90	45.10	74.00	28.90	Peak	Vertical
6	4874.00	28.70	4.90	33.60	54.00	20.40	Average	Vertical
7	7311.00	40.60	6.50	47.10	74.00	26.90	Peak	Vertical
8	7311.00	28.70	6.50	35.20	54.00	18.80	Average	Vertical

IEEE 802.11n20_Highest Channel-1:

No.	Frequency (MHz)	Reading (dBuV/m)	Correction factor (dB)	Result (dBuV/m)	Limit (dBuV/m)	Margin (dB)	Detector	Antenna Polaxis
1	4924.00	38.40	4.00	42.40	74.00	31.60	Peak	Horizontal
2	4924.00	27.40	4.00	31.40	54.00	22.60	Average	Horizontal
3	7386.00	39.80	7.10	46.90	74.00	27.10	Peak	Horizontal
4	7386.00	28.60	7.10	35.70	54.00	18.30	Average	Horizontal
5	4924.00	39.60	5.00	44.60	74.00	29.40	Peak	Vertical
6	4924.00	29.00	5.00	34.00	54.00	20.00	Average	Vertical
7	7386.00	40.60	6.60	47.20	74.00	26.80	Peak	Vertical
8	7386.00	28.70	6.60	35.30	54.00	18.70	Average	Vertical

TEST REPORT

IEEE 802.11n20_Highest Channel-2:

No.	Frequency (MHz)	Reading (dBuV/m)	Correction factor (dB)	Result (dBuV/m)	Limit (dBuV/m)	Margin (dB)	Detector	Antenna Polaxis
1	4934.00	39.50	4.10	43.60	74.00	30.40	Peak	Horizontal
2	4934.00	28.50	4.10	32.60	54.00	21.40	Average	Horizontal
3	7401.00	41.10	7.10	48.20	74.00	25.80	Peak	Horizontal
4	7401.00	29.20	7.10	36.30	54.00	17.70	Average	Horizontal
5	4934.00	39.40	5.10	44.50	74.00	29.50	Peak	Vertical
6	4934.00	28.50	5.10	33.60	54.00	20.40	Average	Vertical
7	7401.00	40.70	6.60	47.30	74.00	26.70	Peak	Vertical
8	7401.00	29.10	6.60	35.70	54.00	18.30	Average	Vertical

IEEE 802.11n20_Highest Channel-3:

No.	Frequency (MHz)	Reading (dBuV/m)	Correction factor (dB)	Result (dBuV/m)	Limit (dBuV/m)	Margin (dB)	Detector	Antenna Polaxis
1	4944.00	40.00	4.10	44.10	74.00	29.90	Peak	Horizontal
2	4944.00	28.60	4.10	32.70	54.00	21.30	Average	Horizontal
3	7416.00	40.50	7.10	47.60	74.00	26.40	Peak	Horizontal
4	7416.00	29.20	7.10	36.30	54.00	17.70	Average	Horizontal
5	4944.00	39.90	5.10	45.00	74.00	29.00	Peak	Vertical
6	4944.00	28.70	5.10	33.80	54.00	20.20	Average	Vertical
7	7416.00	41.70	6.60	48.30	74.00	25.70	Peak	Vertical
8	7416.00	29.20	6.60	35.80	54.00	18.20	Average	Vertical

TEST REPORT

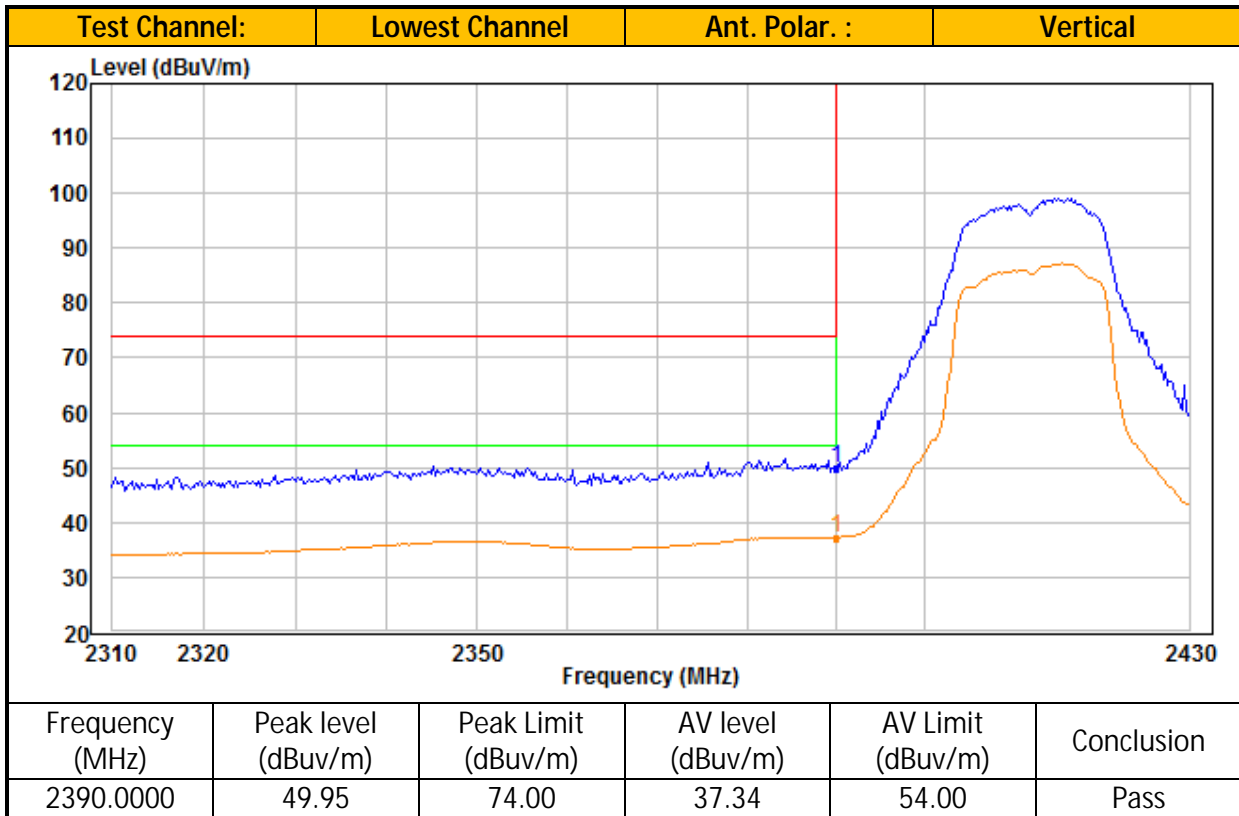
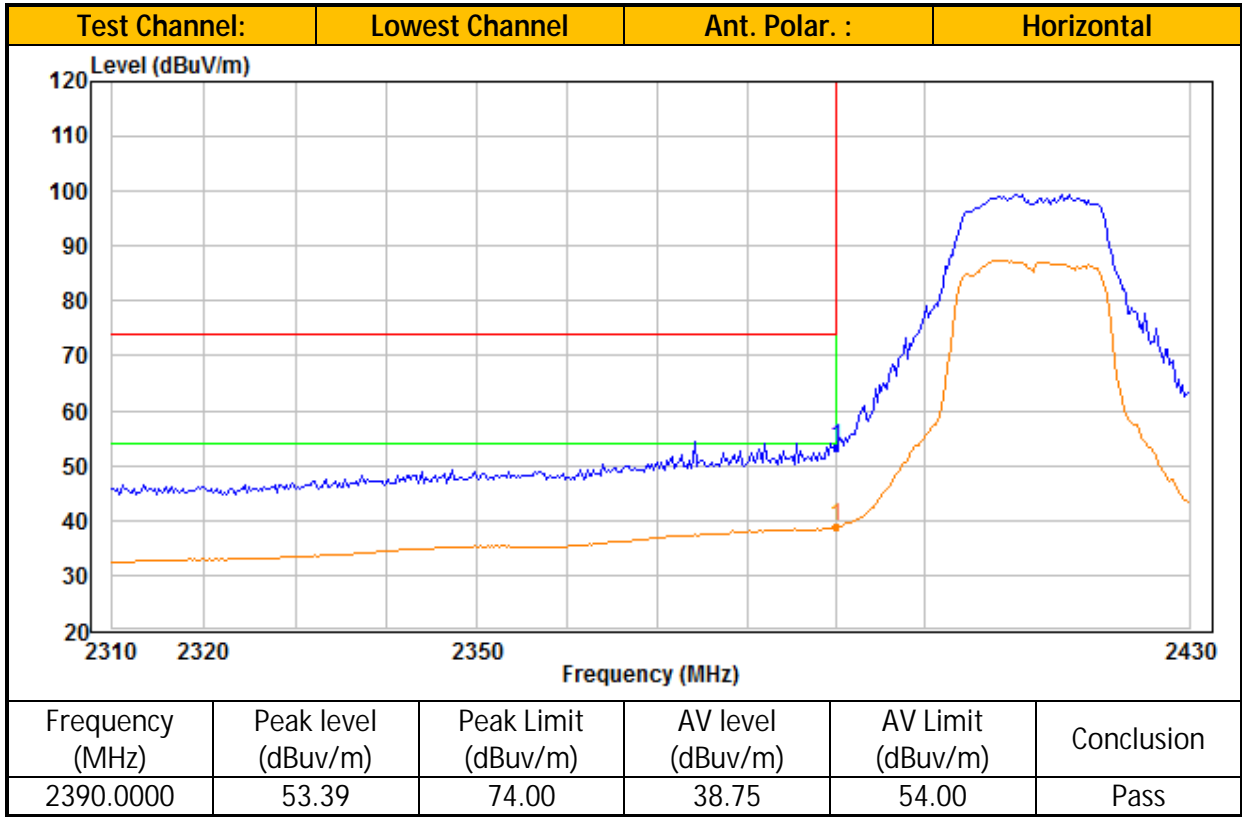

TEST REPORT

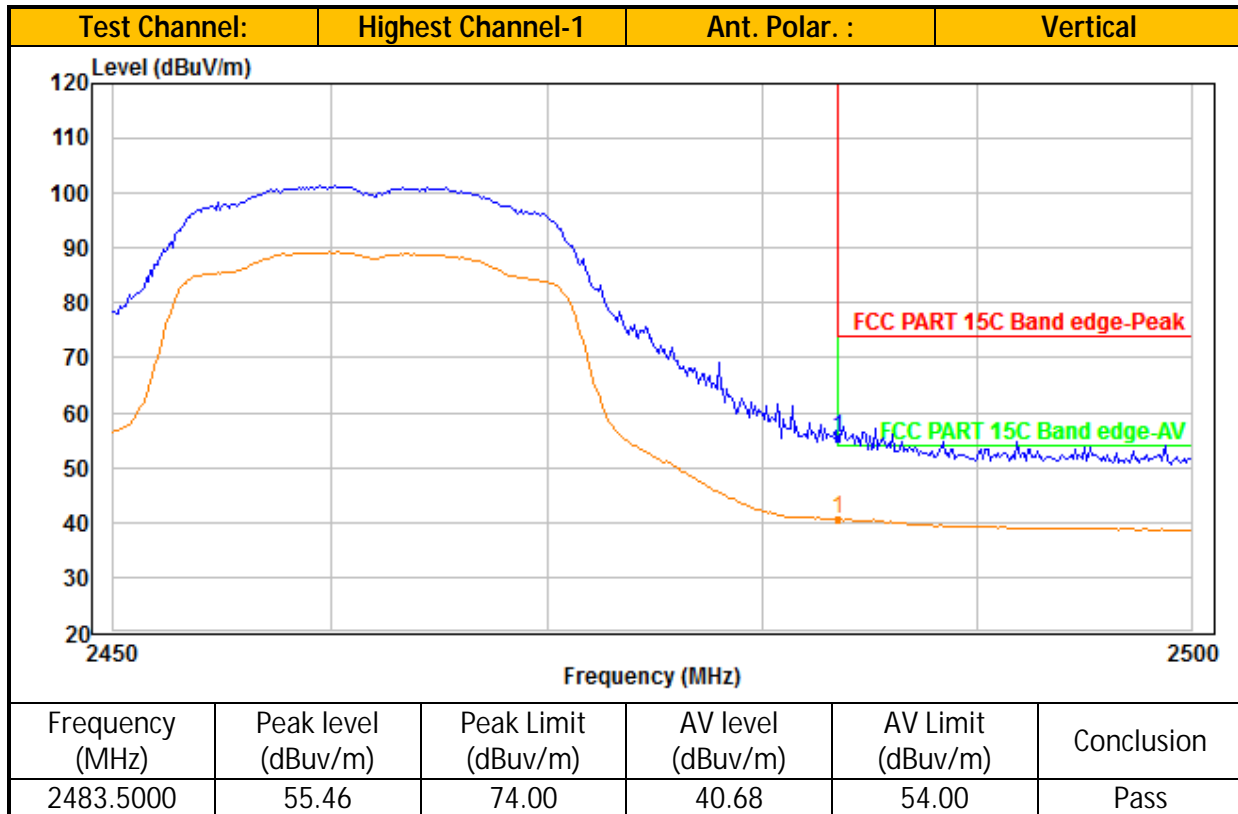
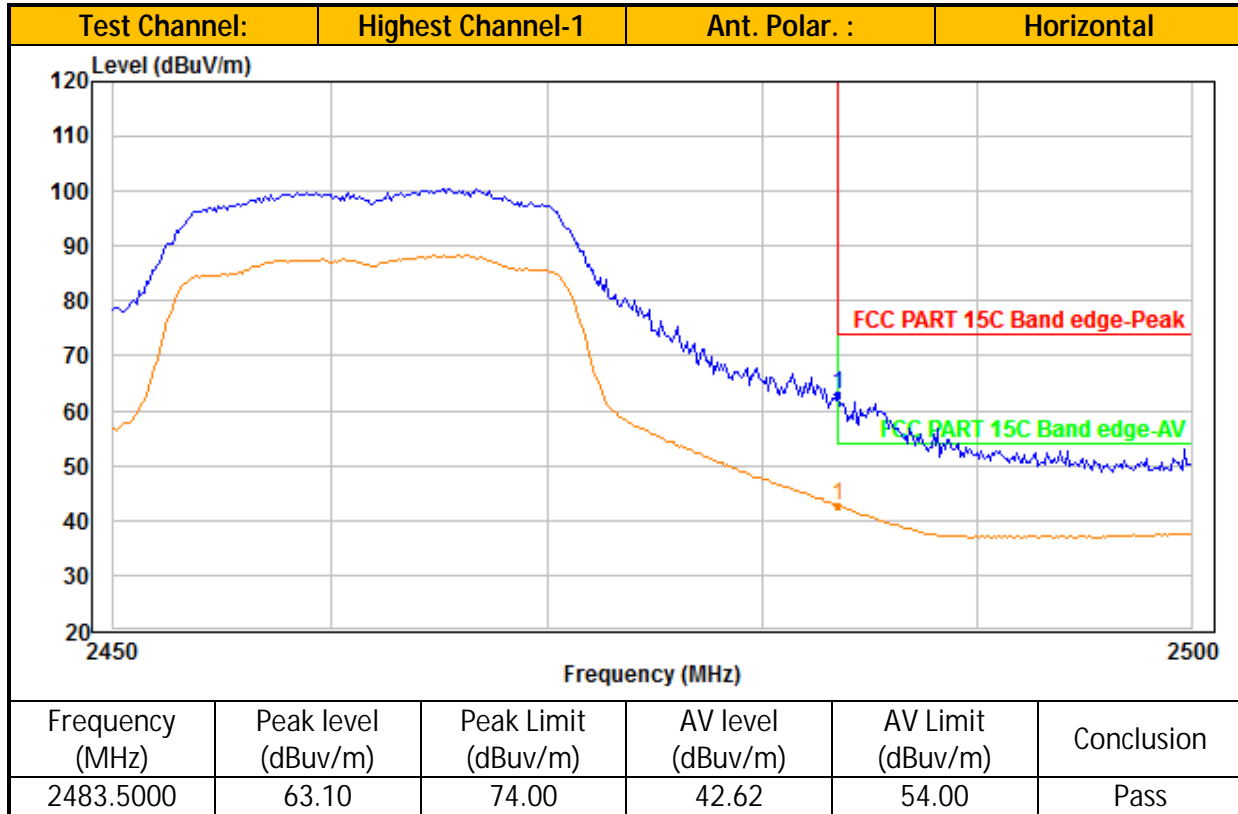

TEST REPORT

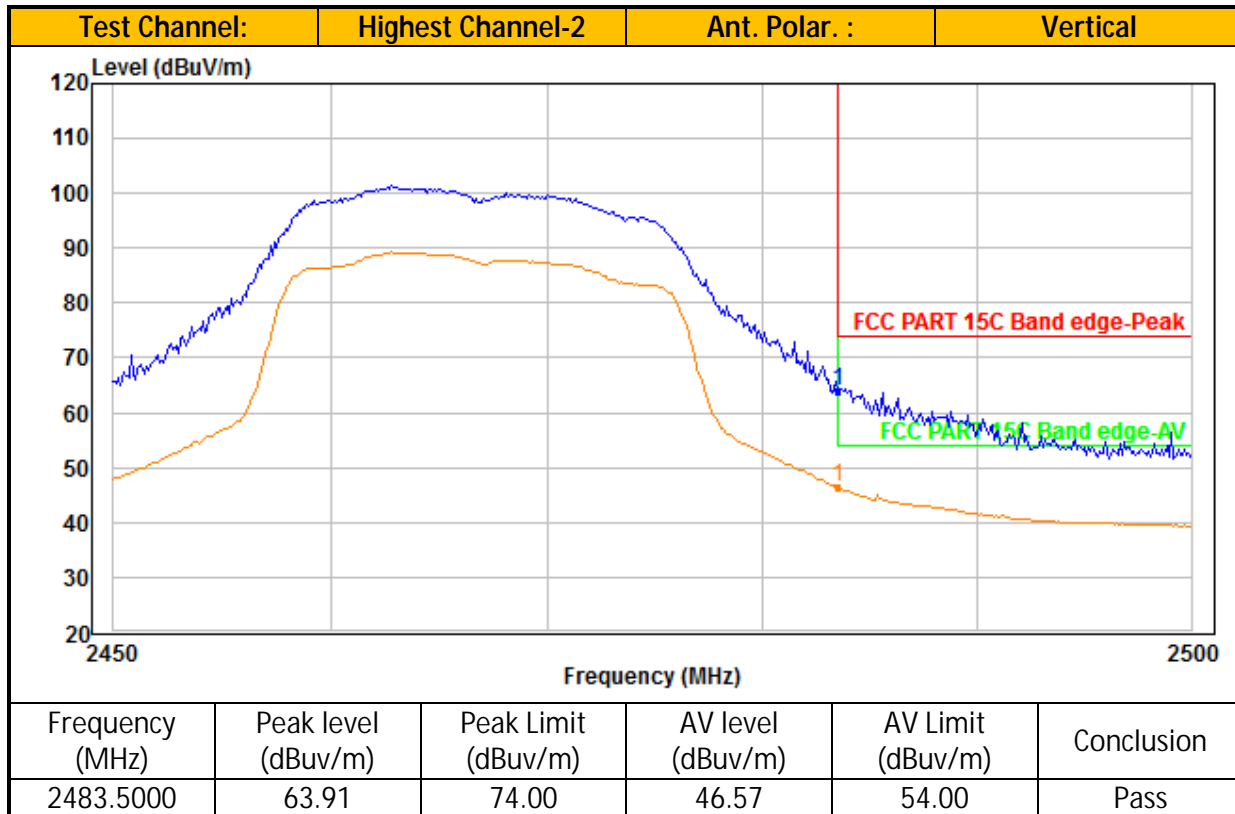
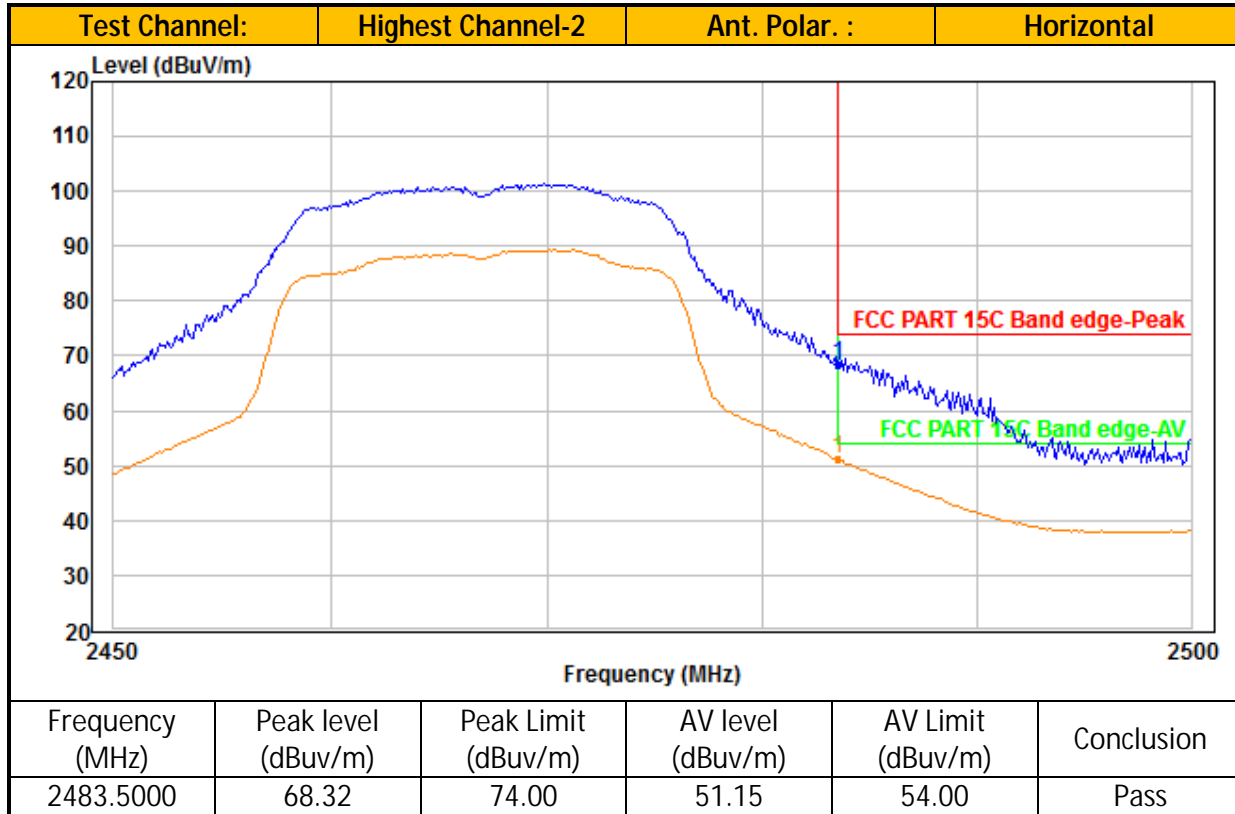

TEST REPORT

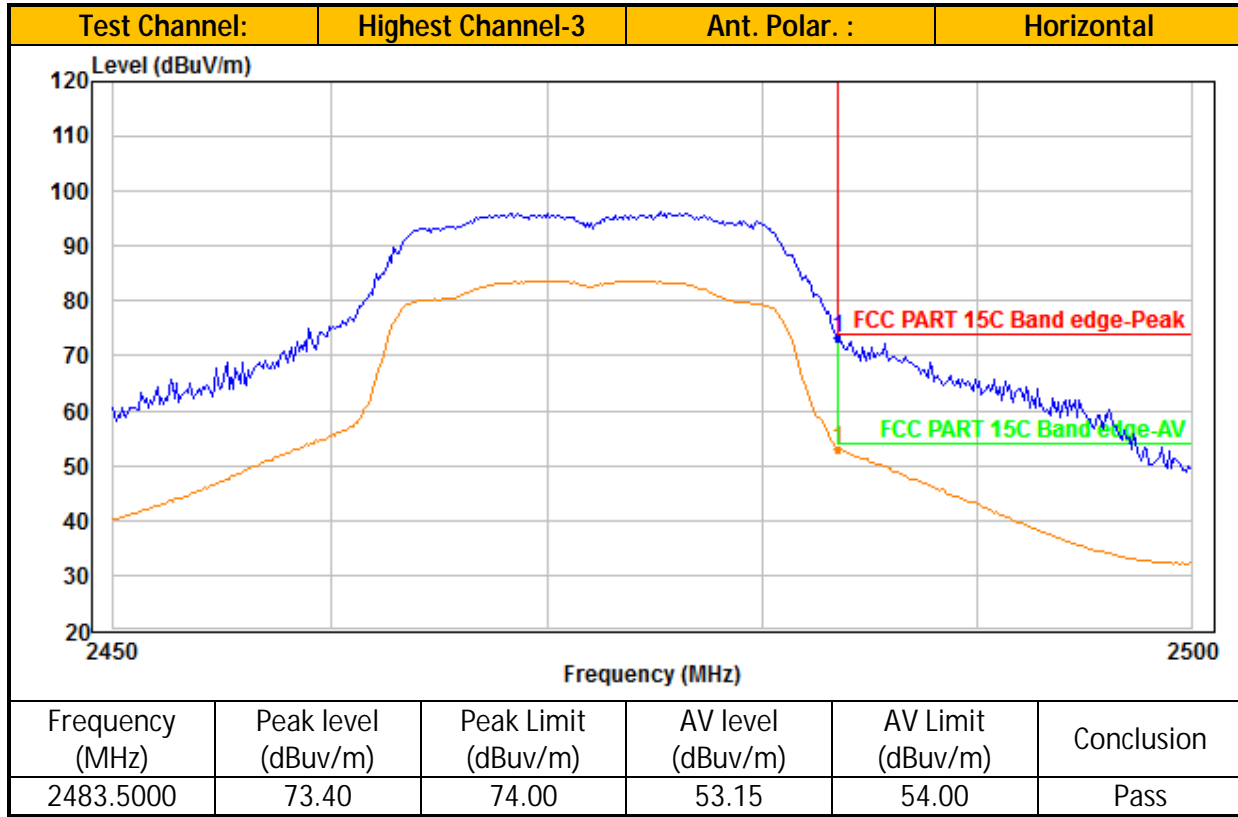

TEST REPORT

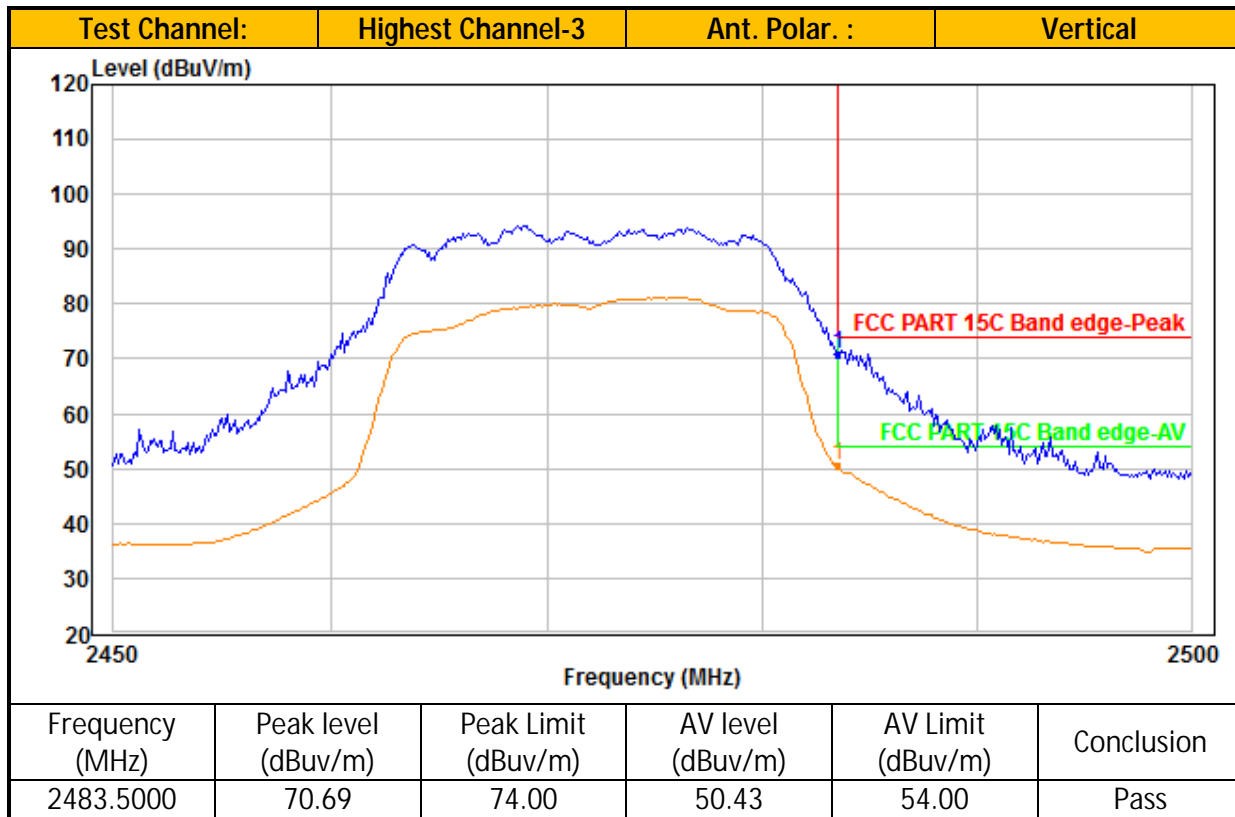

- NOTES:
1. Peak detector is used for the emission measurement.
 2. Average detector is used for the average data of emission measurement
 3. All measurements were made at 3 meters. Radiated emissions not detected at the 3-meter distance were measured at 0.3-meter and an inverse proportional extrapolation was performed to compare the signal level to the 3-meter limit. No other radiated emissions than those reported were detected at a test distance of 0.3-meter.
 4. Value in the margin column shows emission below limit.
 5. Horn antenna is used for the emission over 1000MHz.
 6. Emission (the row indicated by ***bold italic***) within the restricted band meets the requirement of FCC Part 15 Section 15.205.
 7. For the measurement of radiated emission, summation method was used which numerical integrating (in terms of linear power) over the transmitter occupied bandwidth.
 8. For the linear power measurement, data in 1MHz spacing was collected by spectrum analyzer with 1MHz resolution bandwidth.

TEST REPORT

Ant. 1_Table 4
IEEE 802.11n (40MHz) (OFDM, MCS0)

Radiated Emission Test Data (Above 1GHz):
IEEE 802.11n40_Lowest Channel:

No.	Frequency (MHz)	Reading (dBuV/m)	Correction factor (dB)	Result (dBuV/m)	Limit (dBuV/m)	Margin (dB)	Detector	Antenna Polaxis
1	4844.00	35.60	4.00	39.60	74.00	34.40	Peak	Horizontal
2	4844.00	25.10	4.00	29.10	54.00	24.90	Average	Horizontal
3	7266.00	38.70	6.90	45.60	74.00	28.40	Peak	Horizontal
4	7266.00	27.30	6.90	34.20	54.00	19.80	Average	Horizontal
5	4844.00	36.40	5.00	41.40	74.00	32.60	Peak	Vertical
6	4844.00	26.00	5.00	31.00	54.00	23.00	Average	Vertical
7	7266.00	38.50	6.50	45.00	74.00	29.00	Peak	Vertical
8	7266.00	27.10	6.50	33.60	54.00	20.40	Average	Vertical

IEEE 802.11n40_Middle Channel:

No.	Frequency (MHz)	Reading (dBuV/m)	Correction factor (dB)	Result (dBuV/m)	Limit (dBuV/m)	Margin (dB)	Detector	Antenna Polaxis
1	4874.00	37.40	3.90	41.30	74.00	32.70	Peak	Horizontal
2	4874.00	26.10	3.90	30.00	54.00	24.00	Average	Horizontal
3	7311.00	40.00	6.90	46.90	74.00	27.10	Peak	Horizontal
4	7311.00	27.90	6.90	34.80	54.00	19.20	Average	Horizontal
5	4874.00	37.80	4.90	42.70	74.00	31.30	Peak	Vertical
6	4874.00	26.50	4.90	31.40	54.00	22.60	Average	Vertical
7	7311.00	39.00	6.50	45.50	74.00	28.50	Peak	Vertical
8	7311.00	27.80	6.50	34.30	54.00	19.70	Average	Vertical

IEEE 802.11n40_Highest Channel-1:

No.	Frequency (MHz)	Reading (dBuV/m)	Correction factor (dB)	Result (dBuV/m)	Limit (dBuV/m)	Margin (dB)	Detector	Antenna Polaxis
1	4904.00	36.10	4.00	40.10	74.00	33.90	Peak	Horizontal
2	4904.00	25.00	4.00	29.00	54.00	25.00	Average	Horizontal
3	7356.00	39.10	7.00	46.10	74.00	27.90	Peak	Horizontal
4	7356.00	28.00	7.00	35.00	54.00	19.00	Average	Horizontal
5	4904.00	37.20	5.00	42.20	74.00	31.80	Peak	Vertical
6	4904.00	26.10	5.00	31.10	54.00	22.90	Average	Vertical
7	7356.00	38.80	6.50	45.30	74.00	28.70	Peak	Vertical
8	7356.00	27.80	6.50	34.30	54.00	19.70	Average	Vertical

TEST REPORT

IEEE 802.11n40_Highest Channel-2:

No.	Frequency (MHz)	Reading (dBuV/m)	Correction factor (dB)	Result (dBuV/m)	Limit (dBuV/m)	Margin (dB)	Detector	Antenna Polaxis
1	4914.00	39.10	3.90	43.00	74.00	31.00	Peak	Horizontal
2	4914.00	28.60	3.90	32.50	54.00	21.50	Average	Horizontal
3	7371.00	40.90	7.10	48.00	74.00	26.00	Peak	Horizontal
4	7371.00	29.20	7.10	36.30	54.00	17.70	Average	Horizontal
5	4914.00	40.30	4.90	45.20	74.00	28.80	Peak	Vertical
6	4914.00	28.40	4.90	33.30	54.00	20.70	Average	Vertical
7	7371.00	41.30	6.60	47.90	74.00	26.10	Peak	Vertical
8	7371.00	29.00	6.60	35.60	54.00	18.40	Average	Vertical

IEEE 802.11n40_Highest Channel-3:

No.	Frequency (MHz)	Reading (dBuV/m)	Correction factor (dB)	Result (dBuV/m)	Limit (dBuV/m)	Margin (dB)	Detector	Antenna Polaxis
1	4924.00	40.10	4.00	44.10	74.00	29.90	Peak	Horizontal
2	4924.00	29.00	4.00	33.00	54.00	21.00	Average	Horizontal
3	7386.00	40.70	7.10	47.80	74.00	26.20	Peak	Horizontal
4	7386.00	29.30	7.10	36.40	54.00	17.60	Average	Horizontal
5	4924.00	40.00	5.00	45.00	74.00	29.00	Peak	Vertical
6	4924.00	28.70	5.00	33.70	54.00	20.30	Average	Vertical
7	7386.00	40.60	6.60	47.20	74.00	26.80	Peak	Vertical
8	7386.00	29.10	6.60	35.70	54.00	18.30	Average	Vertical

TEST REPORT

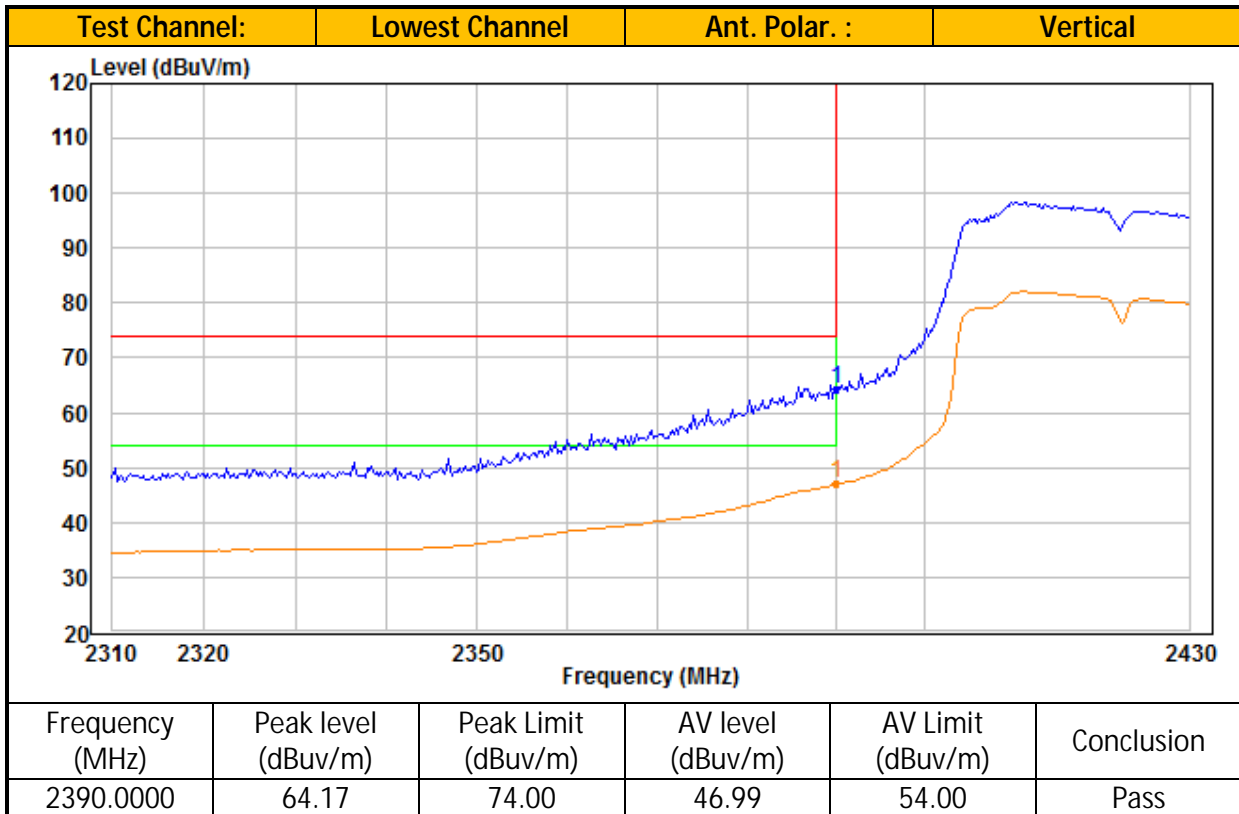
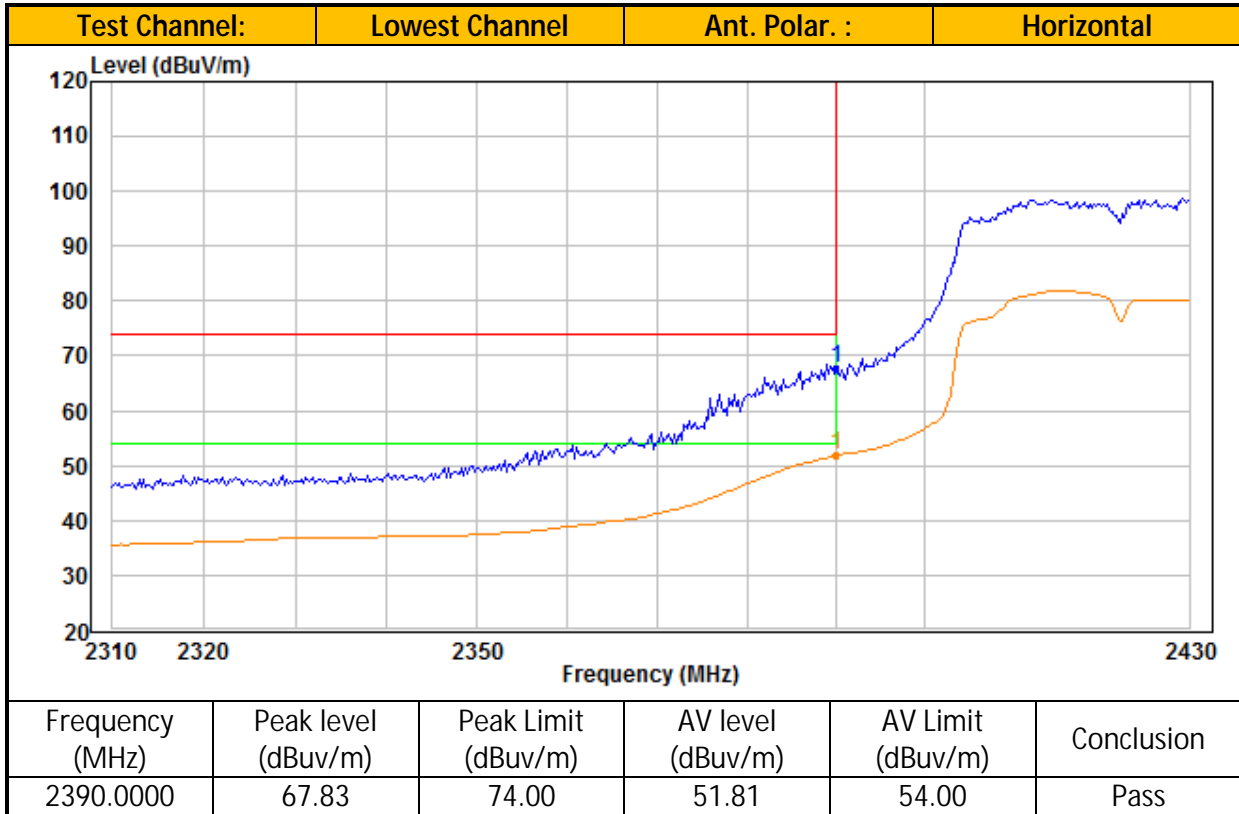

TEST REPORT

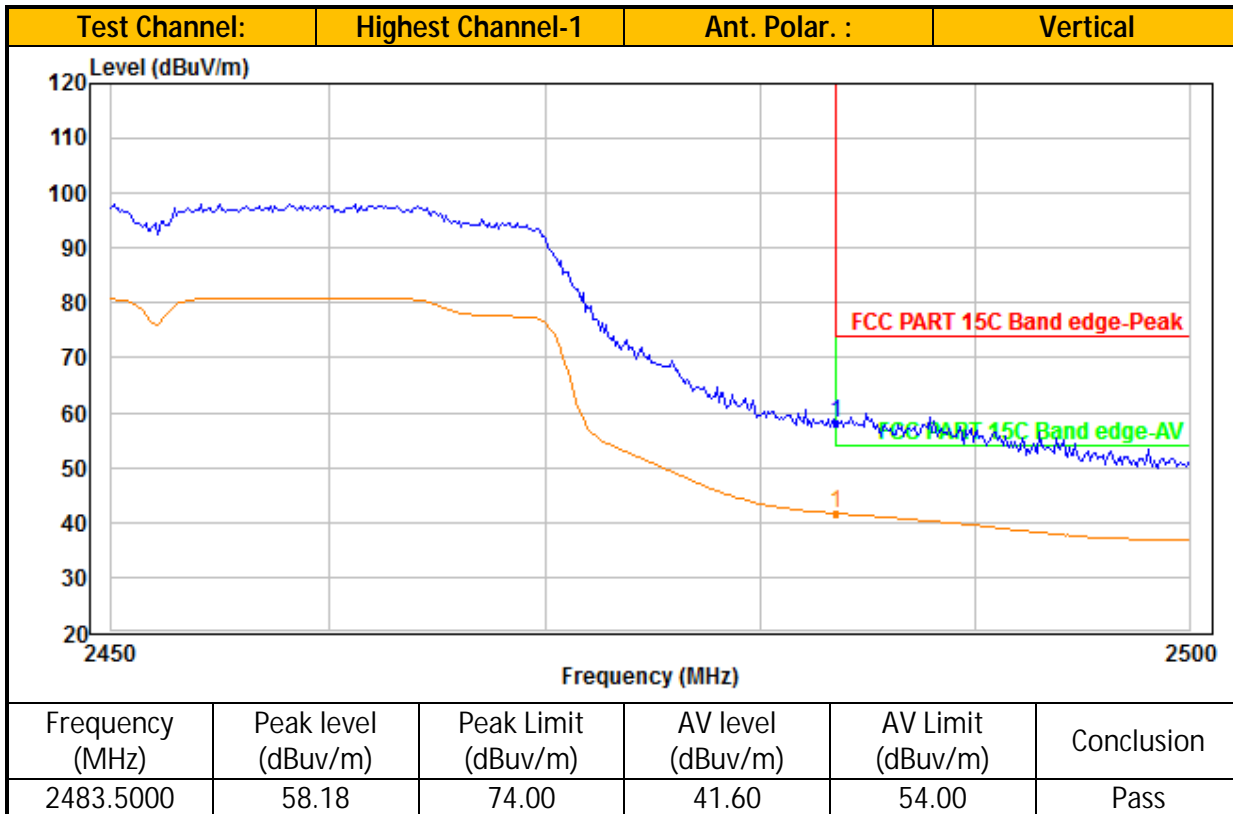
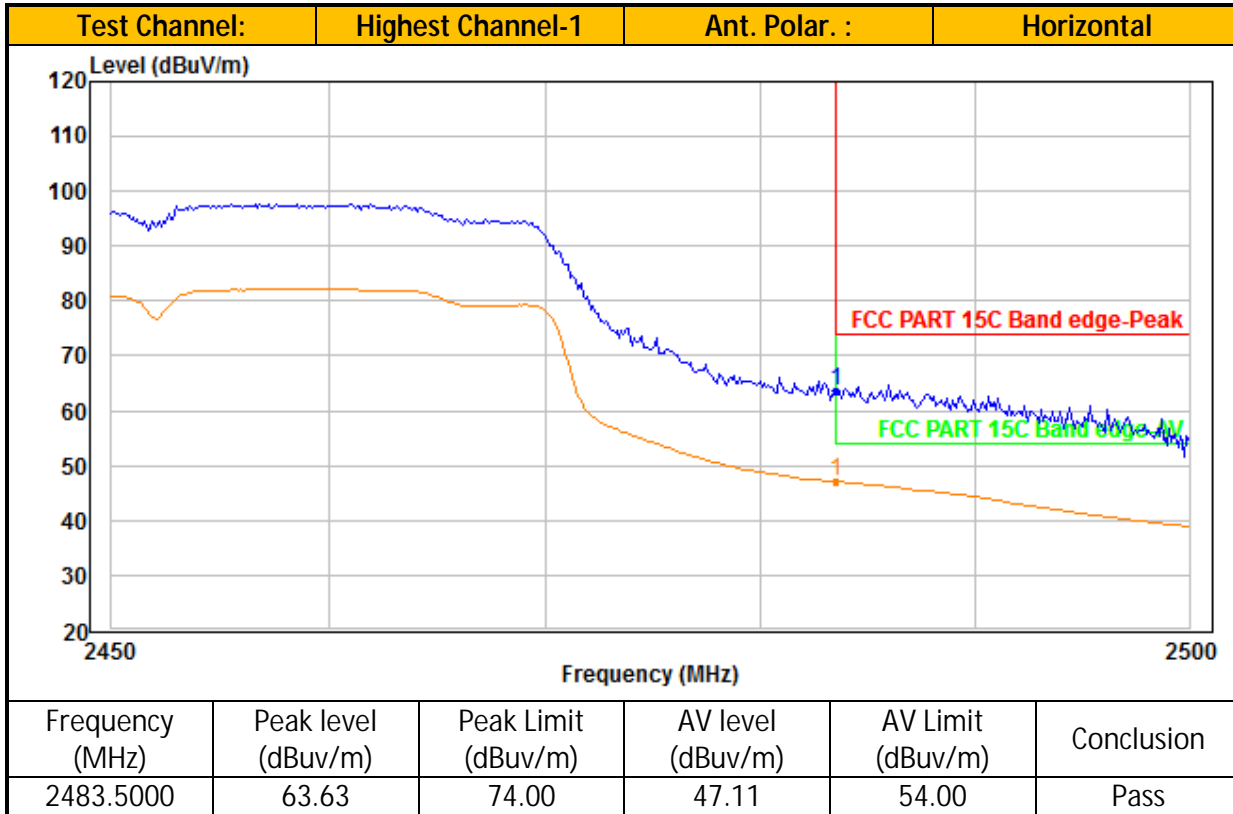

TEST REPORT

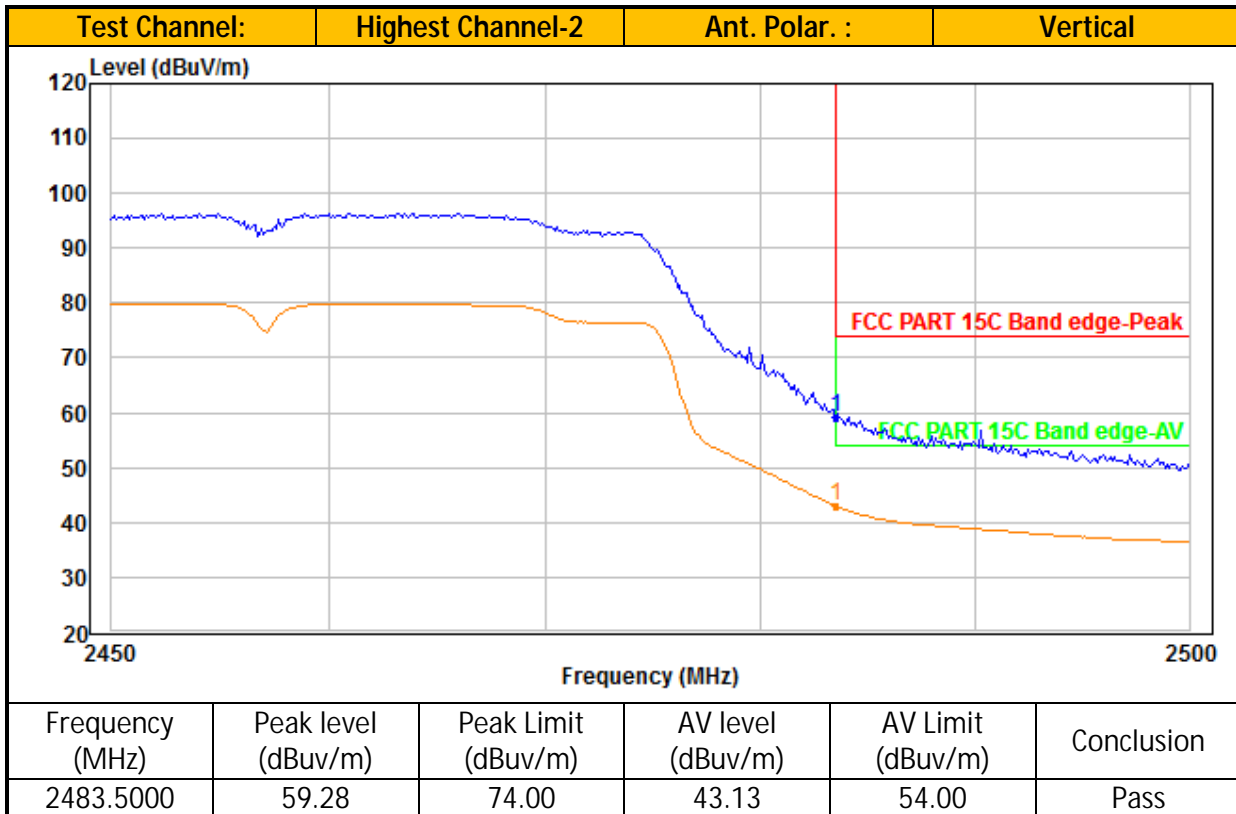
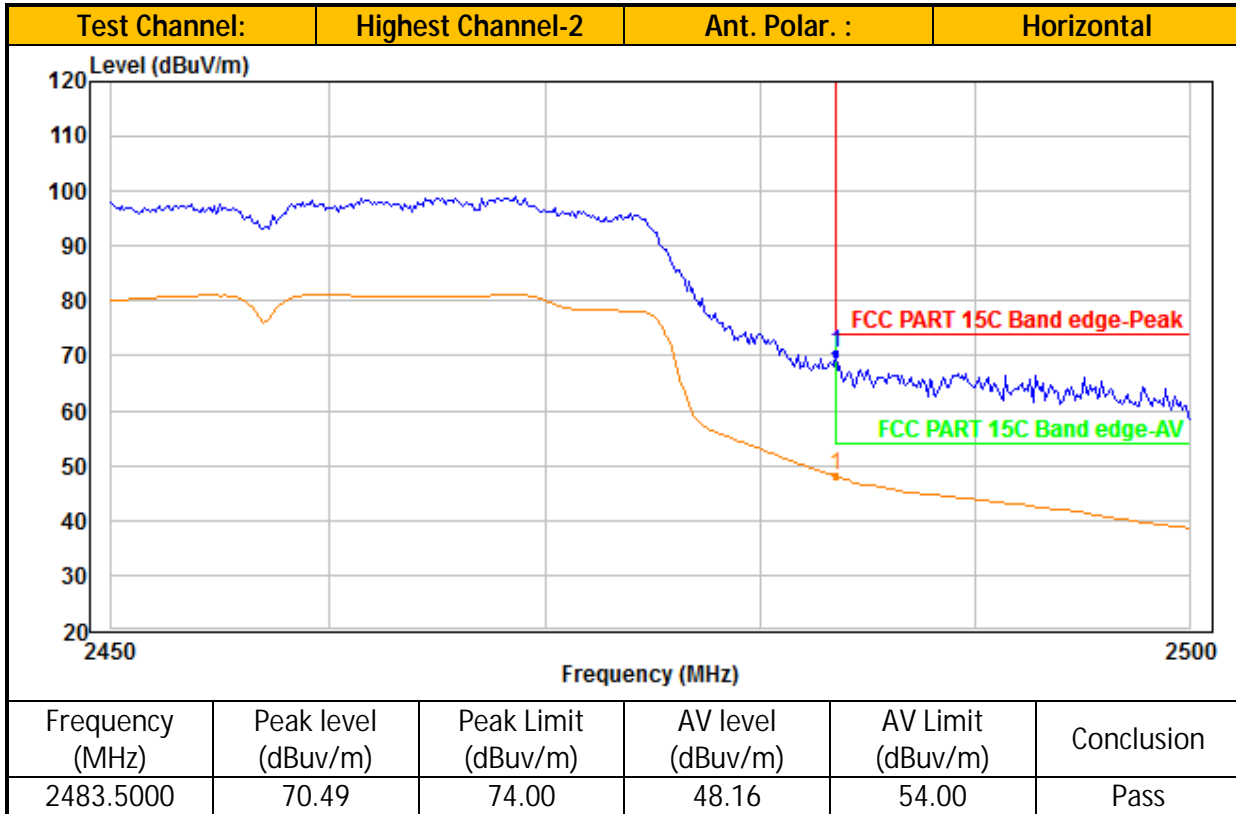

TEST REPORT

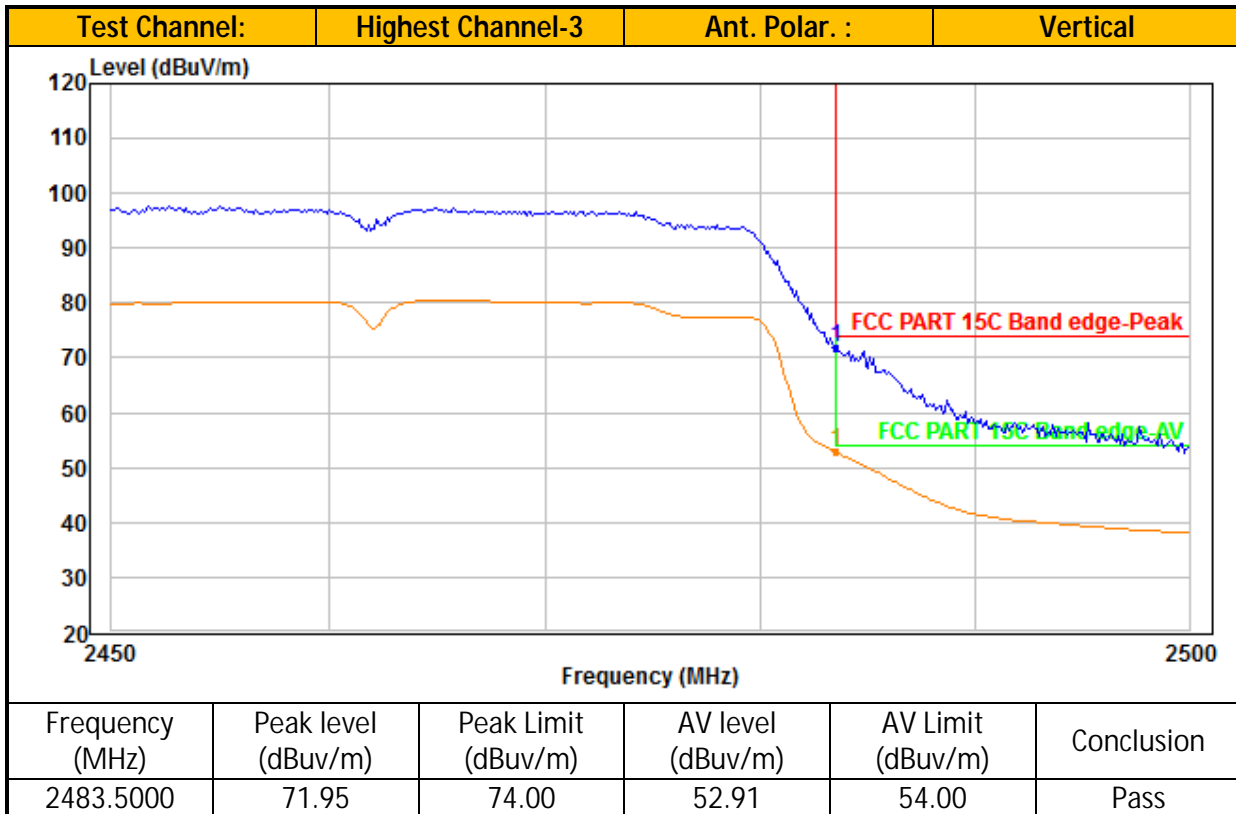
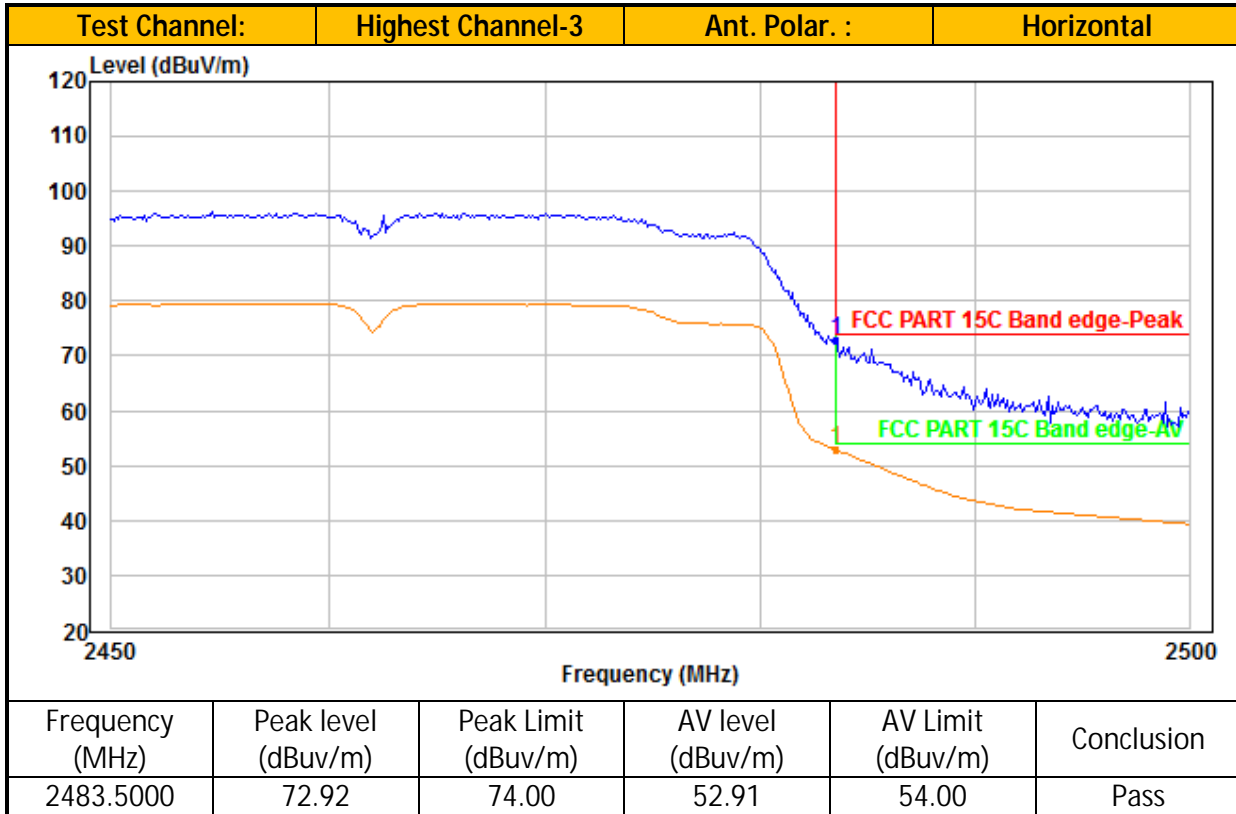

TEST REPORT

Ant. 2_Table 4
IEEE 802.11n (40MHz) (OFDM, MCS0)

Radiated Emission Test Data (Above 1GHz):

IEEE 802.11n40_Lowest Channel:

No.	Frequency (MHz)	Reading (dBuV/m)	Correction factor (dB)	Result (dBuV/m)	Limit (dBuV/m)	Margin (dB)	Detector	Antenna Polaxis
1	4844.00	39.40	4.00	43.40	74.00	30.60	Peak	Horizontal
2	4844.00	28.10	4.00	32.10	54.00	21.90	Average	Horizontal
3	7266.00	39.90	6.90	46.80	74.00	27.20	Peak	Horizontal
4	7266.00	28.60	6.90	35.50	54.00	18.50	Average	Horizontal
5	4844.00	39.00	5.00	44.00	74.00	30.00	Peak	Vertical
6	4844.00	28.70	5.00	33.70	54.00	20.30	Average	Vertical
7	7266.00	40.90	6.50	47.40	74.00	26.60	Peak	Vertical
8	7266.00	28.40	6.50	34.90	54.00	19.10	Average	Vertical

IEEE 802.11n40_Middle Channel:

No.	Frequency (MHz)	Reading (dBuV/m)	Correction factor (dB)	Result (dBuV/m)	Limit (dBuV/m)	Margin (dB)	Detector	Antenna Polaxis
1	4874.00	40.70	3.90	44.60	74.00	29.40	Peak	Horizontal
2	4874.00	28.50	3.90	32.40	54.00	21.60	Average	Horizontal
3	7311.00	41.10	6.90	48.00	74.00	26.00	Peak	Horizontal
4	7311.00	29.20	6.90	36.10	54.00	17.90	Average	Horizontal
5	4874.00	39.40	4.90	44.30	74.00	29.70	Peak	Vertical
6	4874.00	29.40	4.90	34.30	54.00	19.70	Average	Vertical
7	7311.00	40.50	6.50	47.00	74.00	27.00	Peak	Vertical
8	7311.00	29.10	6.50	35.60	54.00	18.40	Average	Vertical

IEEE 802.11n40_Highest Channel-1:

No.	Frequency (MHz)	Reading (dBuV/m)	Correction factor (dB)	Result (dBuV/m)	Limit (dBuV/m)	Margin (dB)	Detector	Antenna Polaxis
1	4904.00	38.90	4.00	42.90	74.00	31.10	Peak	Horizontal
2	4904.00	28.00	4.00	32.00	54.00	22.00	Average	Horizontal
3	7356.00	41.10	7.00	48.10	74.00	25.90	Peak	Horizontal
4	7356.00	29.20	7.00	36.20	54.00	17.80	Average	Horizontal
5	4904.00	40.20	5.00	45.20	74.00	28.80	Peak	Vertical
6	4904.00	28.10	5.00	33.10	54.00	20.90	Average	Vertical
7	7356.00	40.80	6.50	47.30	74.00	26.70	Peak	Vertical
8	7356.00	29.00	6.50	35.50	54.00	18.50	Average	Vertical

TEST REPORT

IEEE 802.11n40_Highest Channel-2:

No.	Frequency (MHz)	Reading (dBuV/m)	Correction factor (dB)	Result (dBuV/m)	Limit (dBuV/m)	Margin (dB)	Detector	Antenna Polaxis
1	4914.00	41.60	3.90	45.50	74.00	28.50	Peak	Horizontal
2	4914.00	29.00	3.90	32.90	54.00	21.10	Average	Horizontal
3	7371.00	41.40	7.10	48.50	74.00	25.50	Peak	Horizontal
4	7371.00	29.40	7.10	36.50	54.00	17.50	Average	Horizontal
5	4914.00	39.70	4.90	44.60	74.00	29.40	Peak	Vertical
6	4914.00	29.00	4.90	33.90	54.00	20.10	Average	Vertical
7	7371.00	40.90	6.60	47.50	74.00	26.50	Peak	Vertical
8	7371.00	29.20	6.60	35.80	54.00	18.20	Average	Vertical

IEEE 802.11n40_Highest Channel-3:

No.	Frequency (MHz)	Reading (dBuV/m)	Correction factor (dB)	Result (dBuV/m)	Limit (dBuV/m)	Margin (dB)	Detector	Antenna Polaxis
1	4924.00	40.90	4.00	44.90	74.00	29.10	Peak	Horizontal
2	4924.00	29.00	4.00	33.00	54.00	21.00	Average	Horizontal
3	7386.00	41.50	7.10	48.60	74.00	25.40	Peak	Horizontal
4	7386.00	29.70	7.10	36.80	54.00	17.20	Average	Horizontal
5	4924.00	40.60	5.00	45.60	74.00	28.40	Peak	Vertical
6	4924.00	29.10	5.00	34.10	54.00	19.90	Average	Vertical
7	7386.00	41.10	6.60	47.70	74.00	26.30	Peak	Vertical
8	7386.00	29.30	6.60	35.90	54.00	18.10	Average	Vertical

TEST REPORT

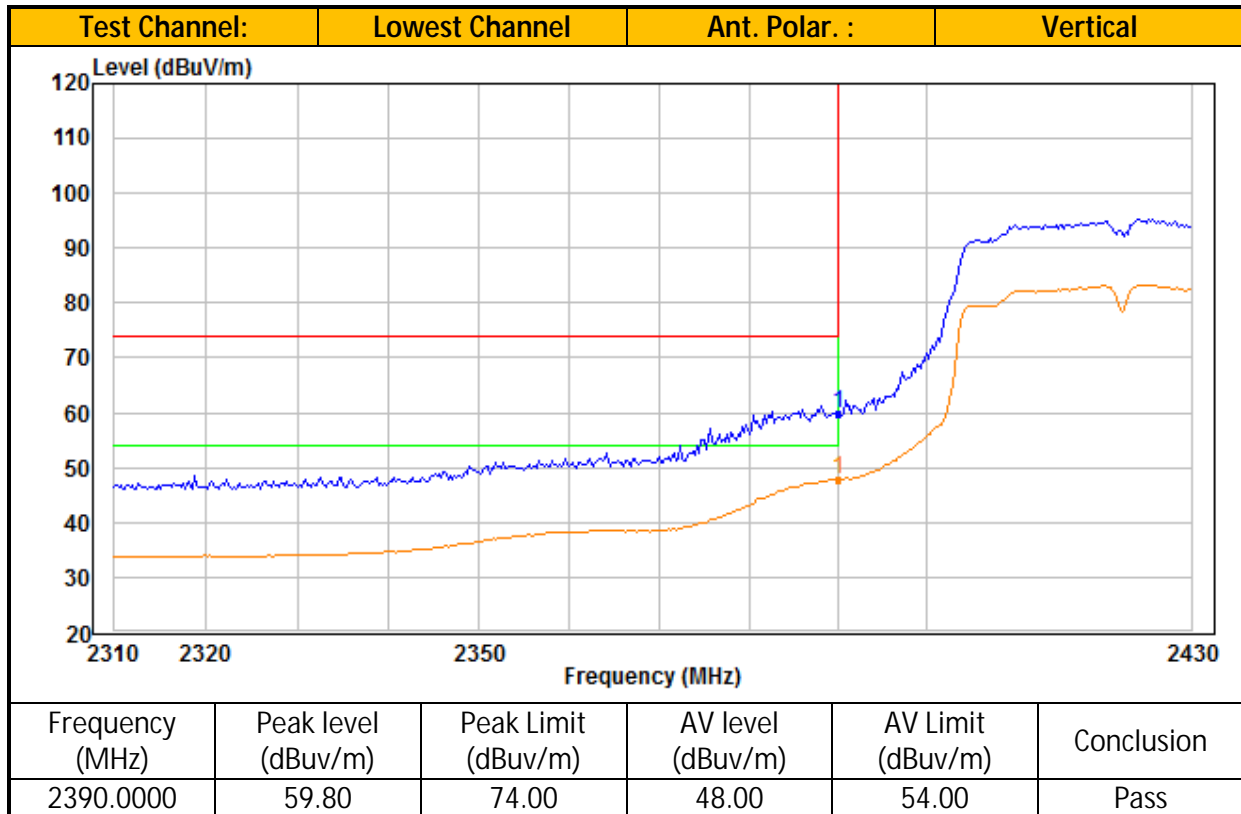
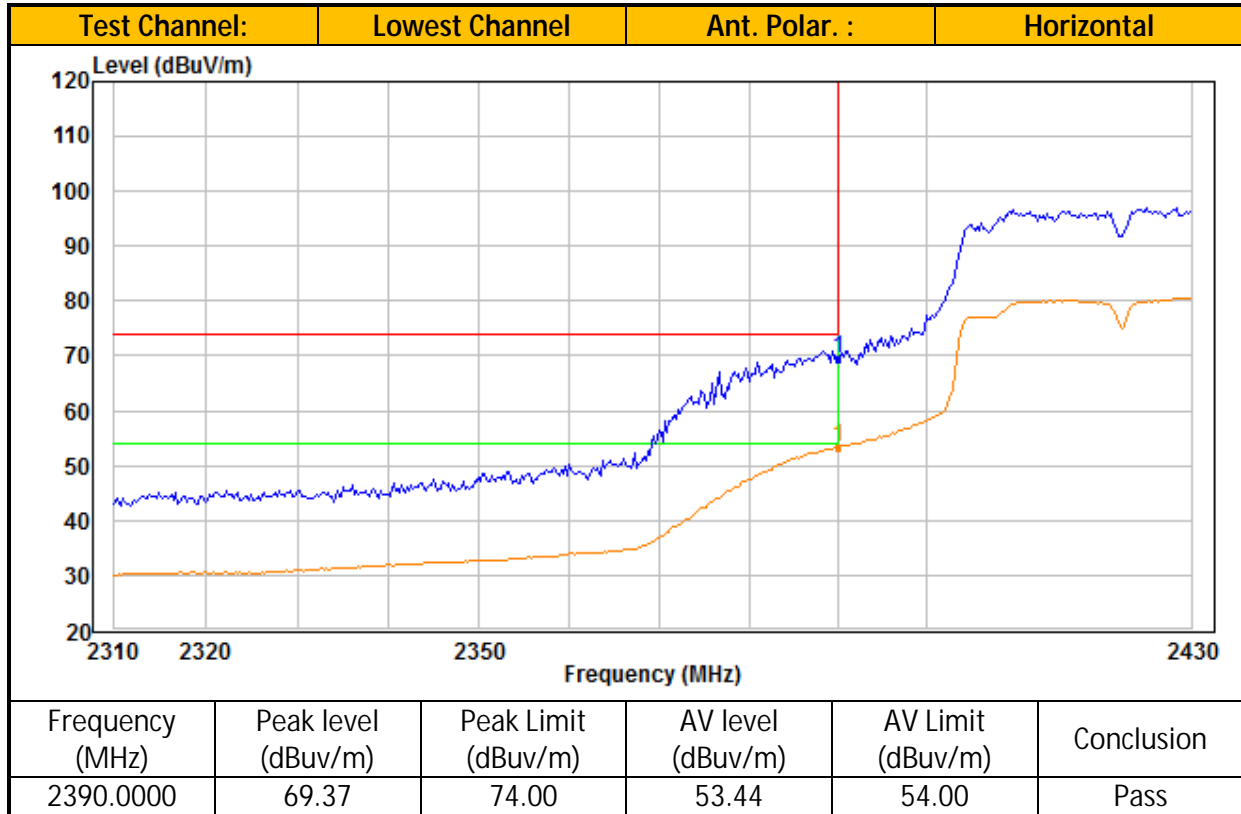

TEST REPORT

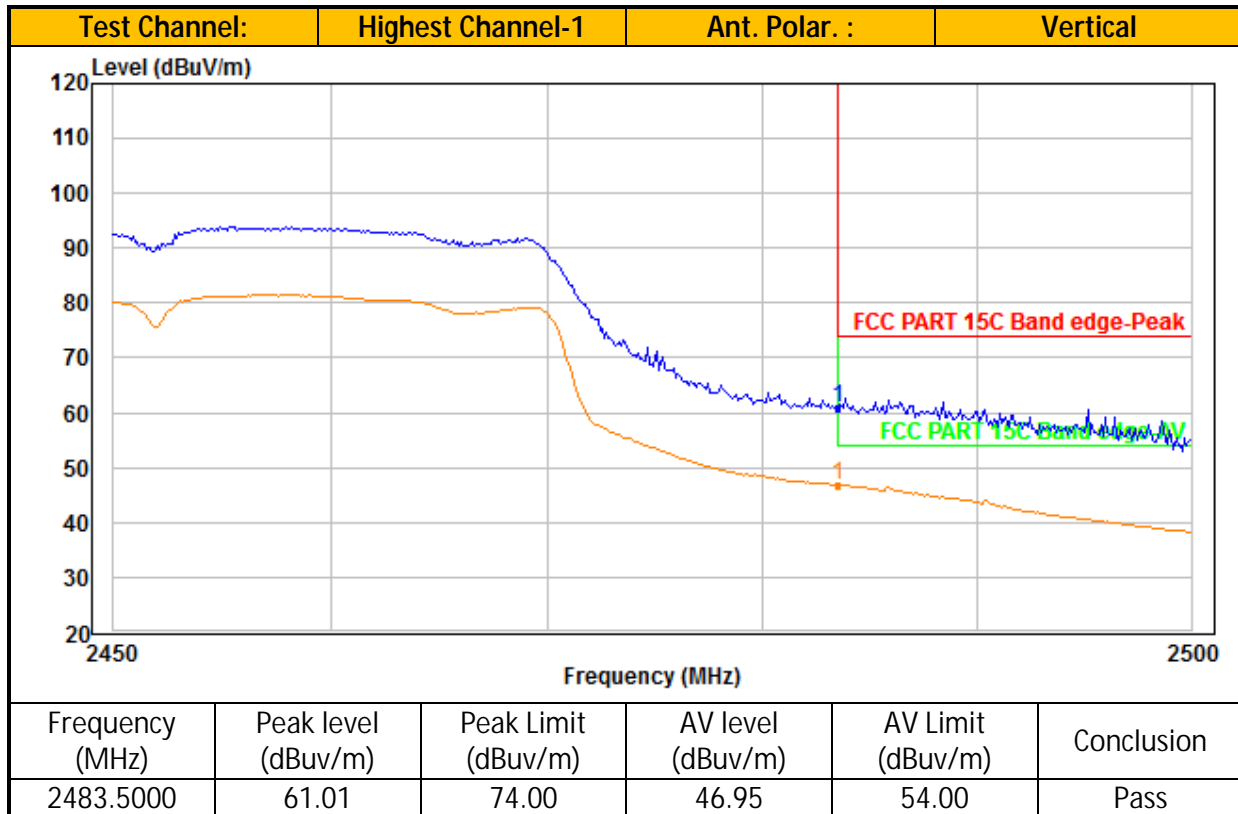
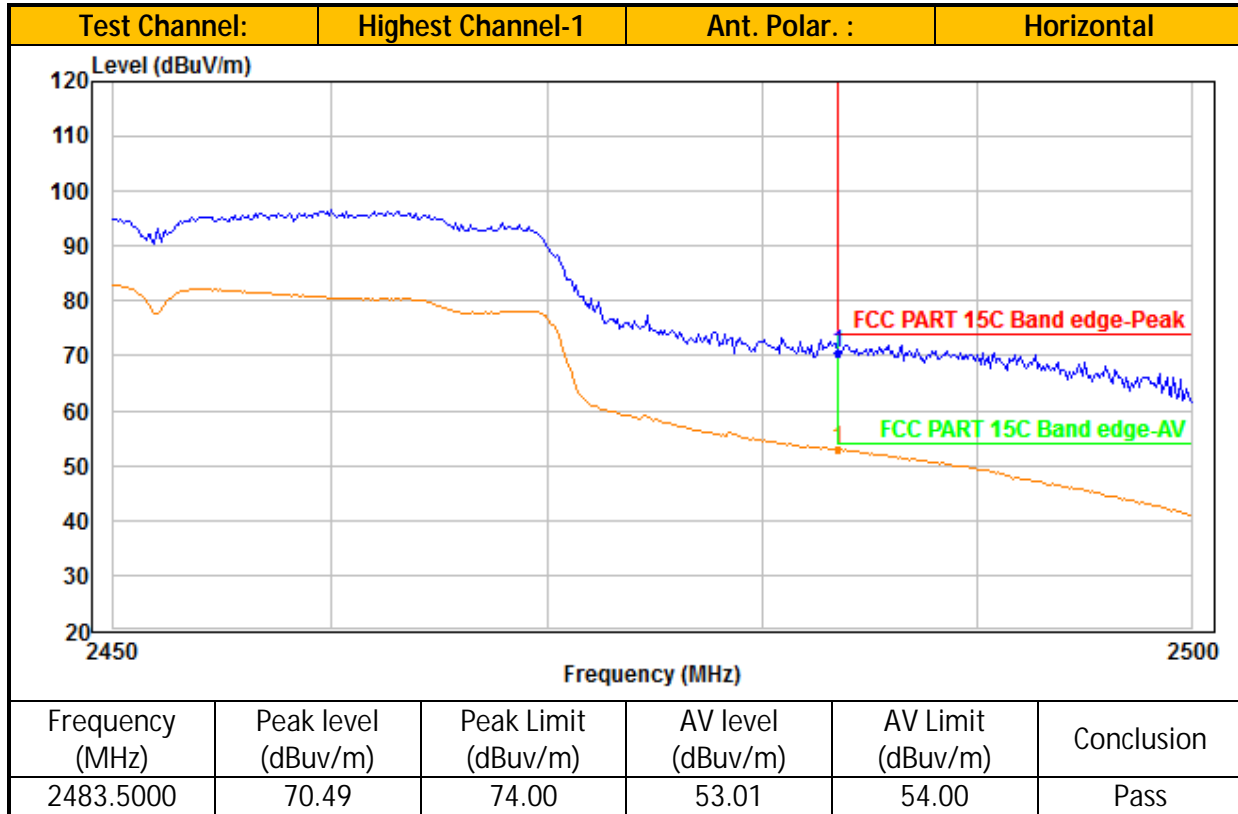

TEST REPORT

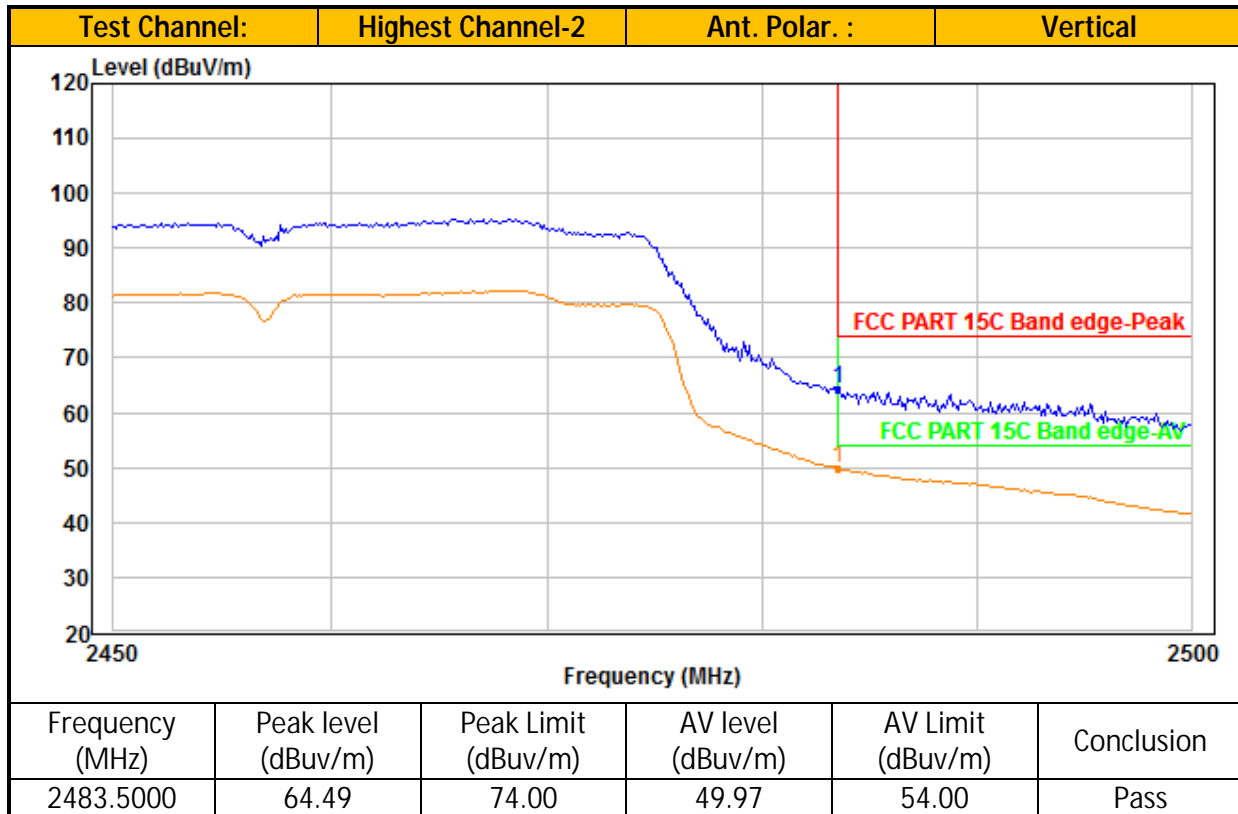
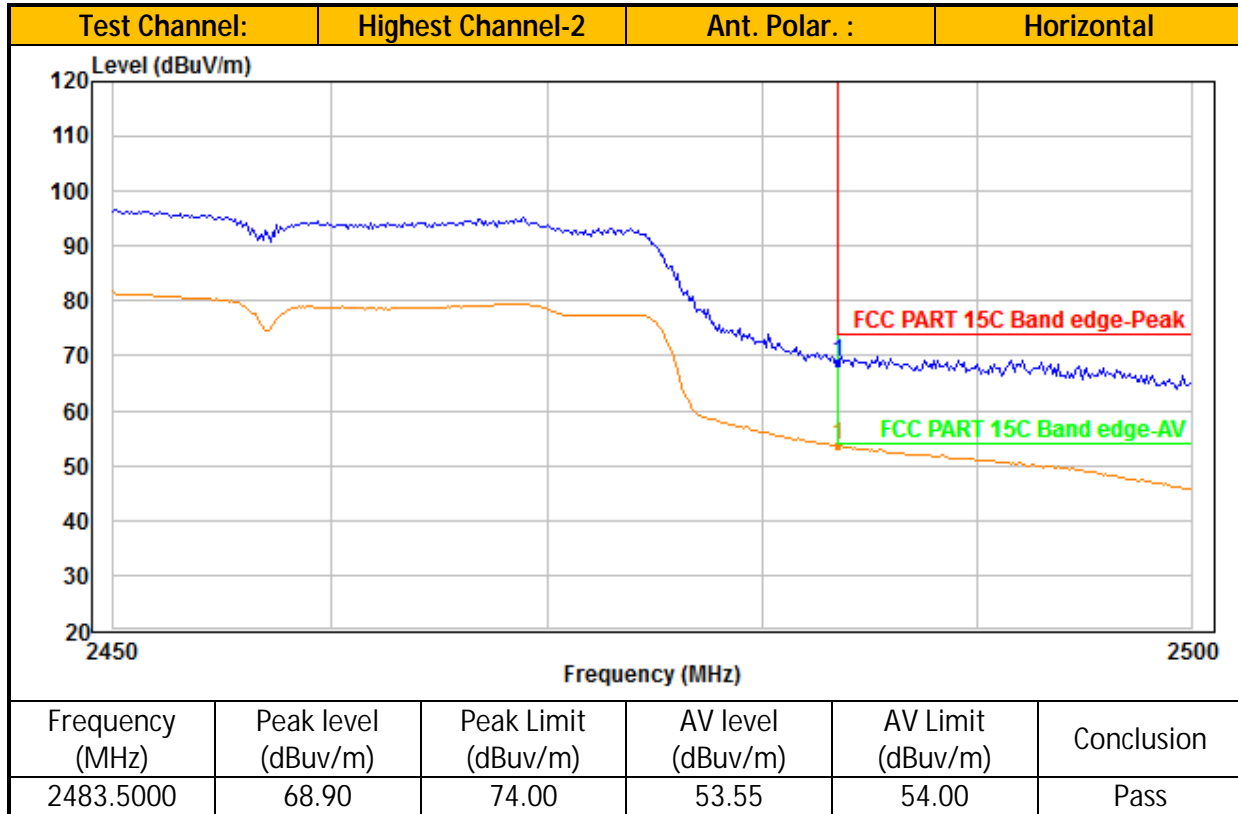

TEST REPORT

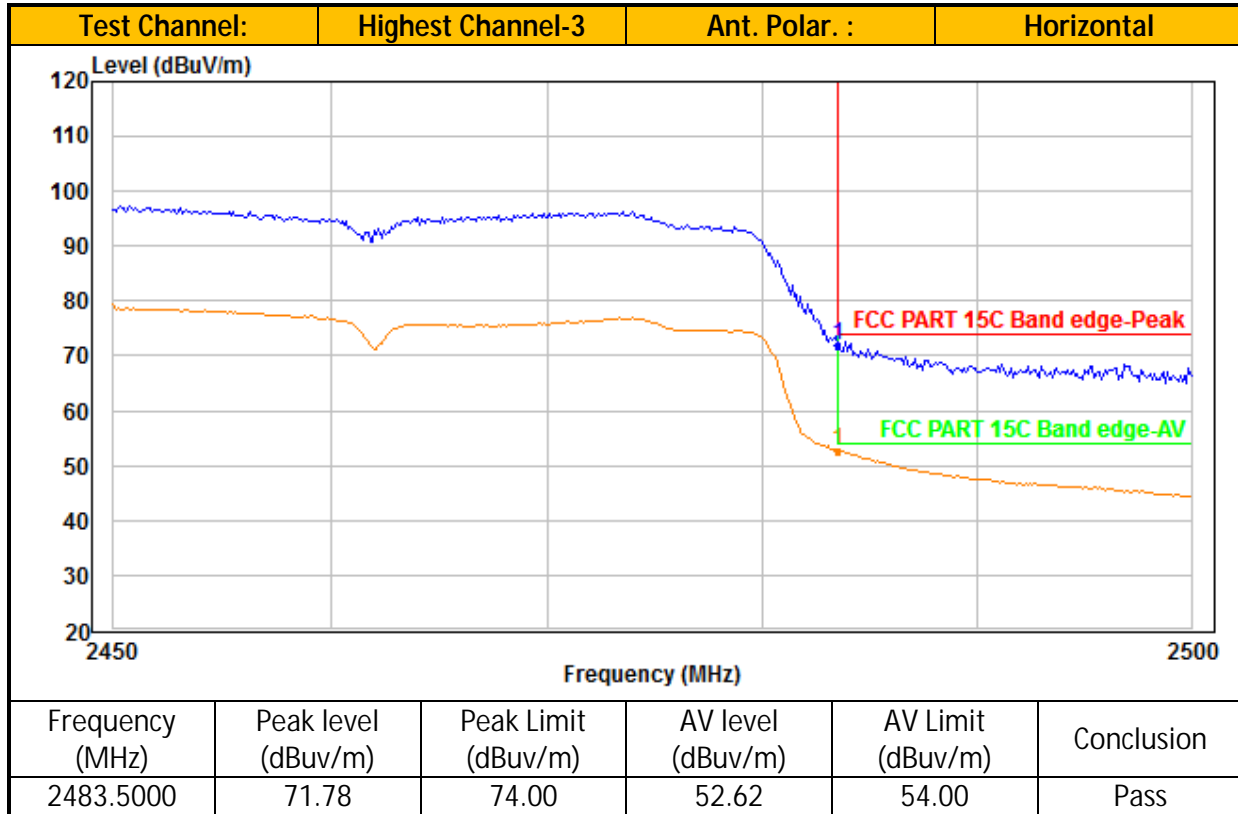

TEST REPORT

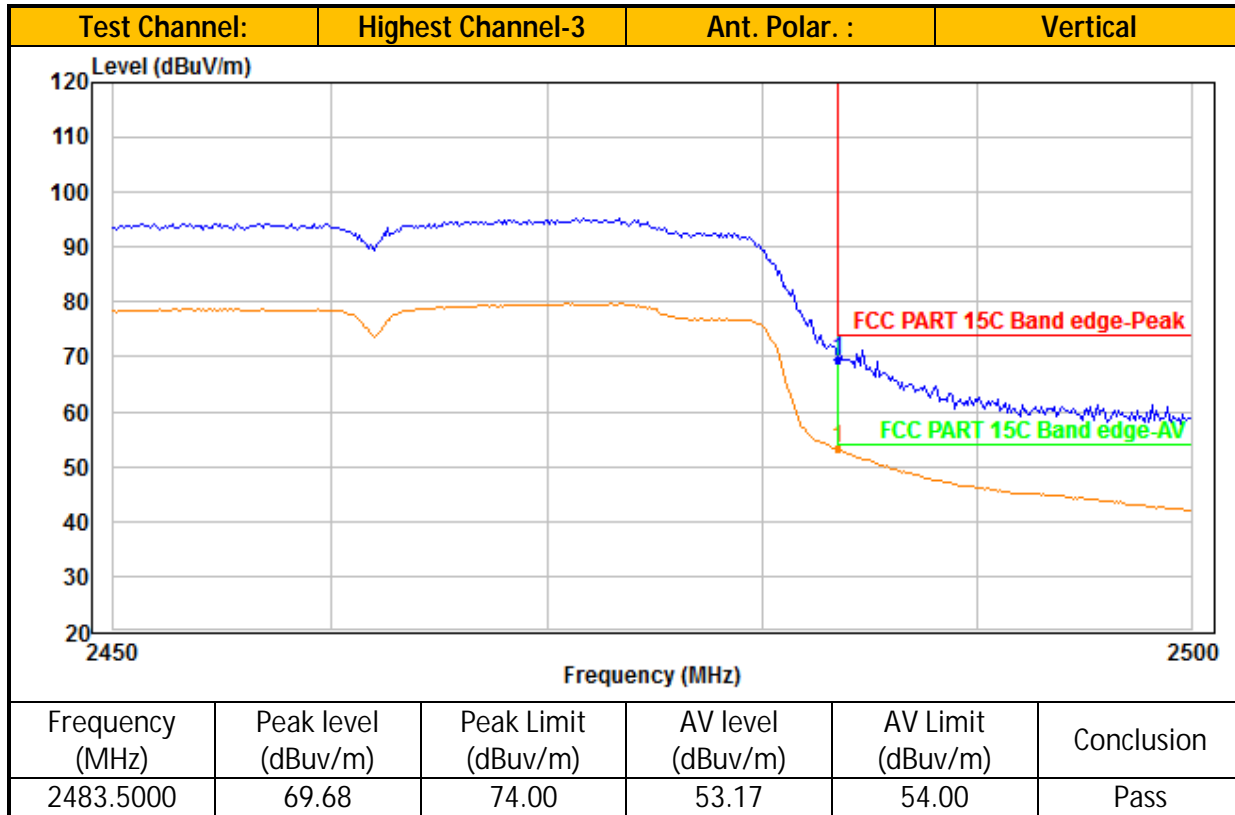

- NOTES:
1. Peak detector is used for the emission measurement.
 2. Average detector is used for the average data of emission measurement
 3. All measurements were made at 3 meters. Radiated emissions not detected at the 3-meter distance were measured at 0.3-meter and an inverse proportional extrapolation was performed to compare the signal level to the 3-meter limit. No other radiated emissions than those reported were detected at a test distance of 0.3-meter.
 7. Value in the margin column shows emission below limit.
 8. Horn antenna is used for the emission over 1000MHz.
 9. Emission (the row indicated by ***bold italic***) within the restricted band meets the requirement of FCC Part 15 Section 15.205.
 7. For the measurement of radiated emission, summation method was used which numerical integrating (in terms of linear power) over the transmitter occupied bandwidth.
 8. For the linear power measurement, data in 1MHz spacing was collected by spectrum analyzer with 1MHz resolution bandwidth.

TEST REPORT

Mode: WIFI Connected

Ant. 1_Table 5

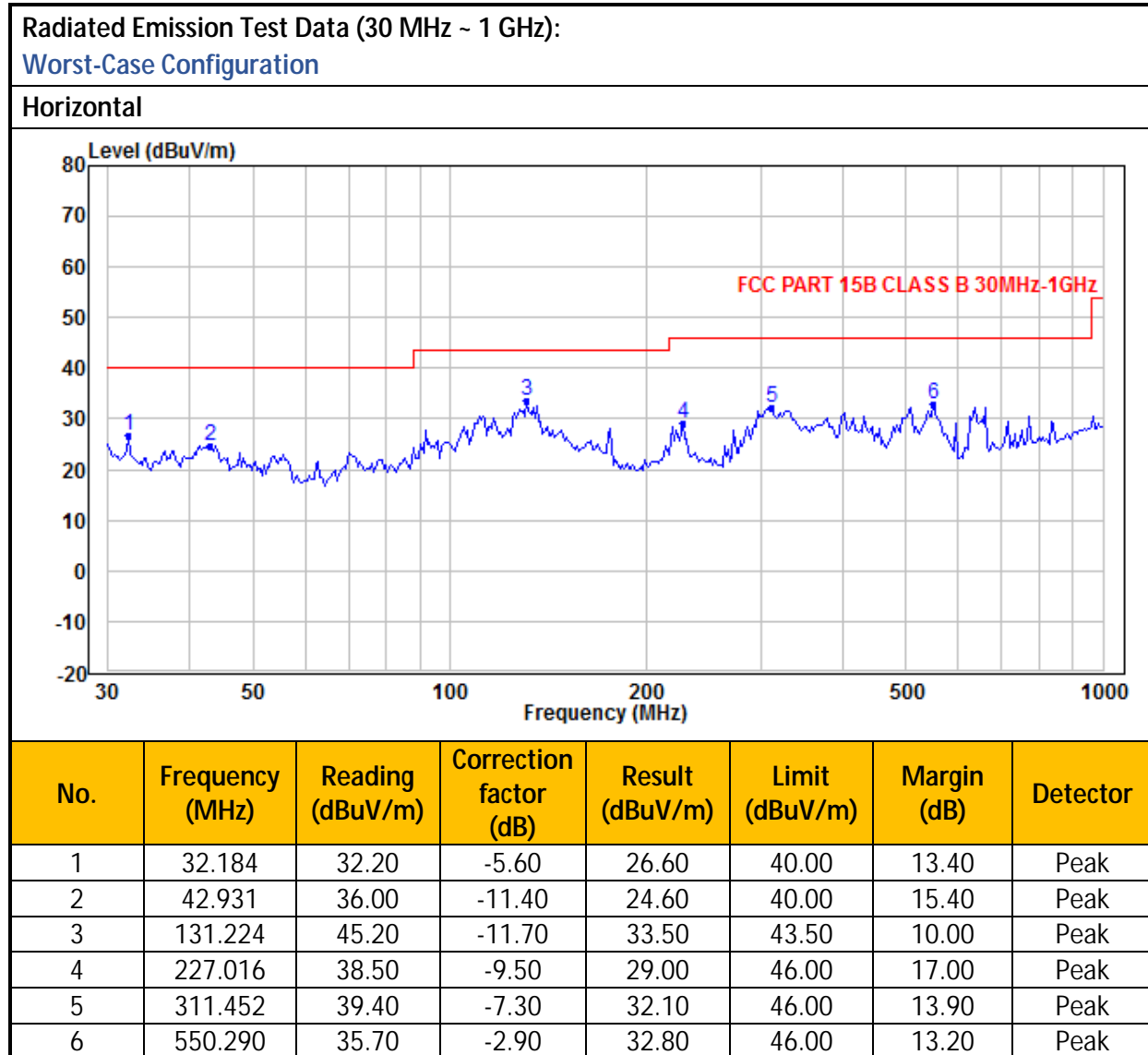

TEST REPORT

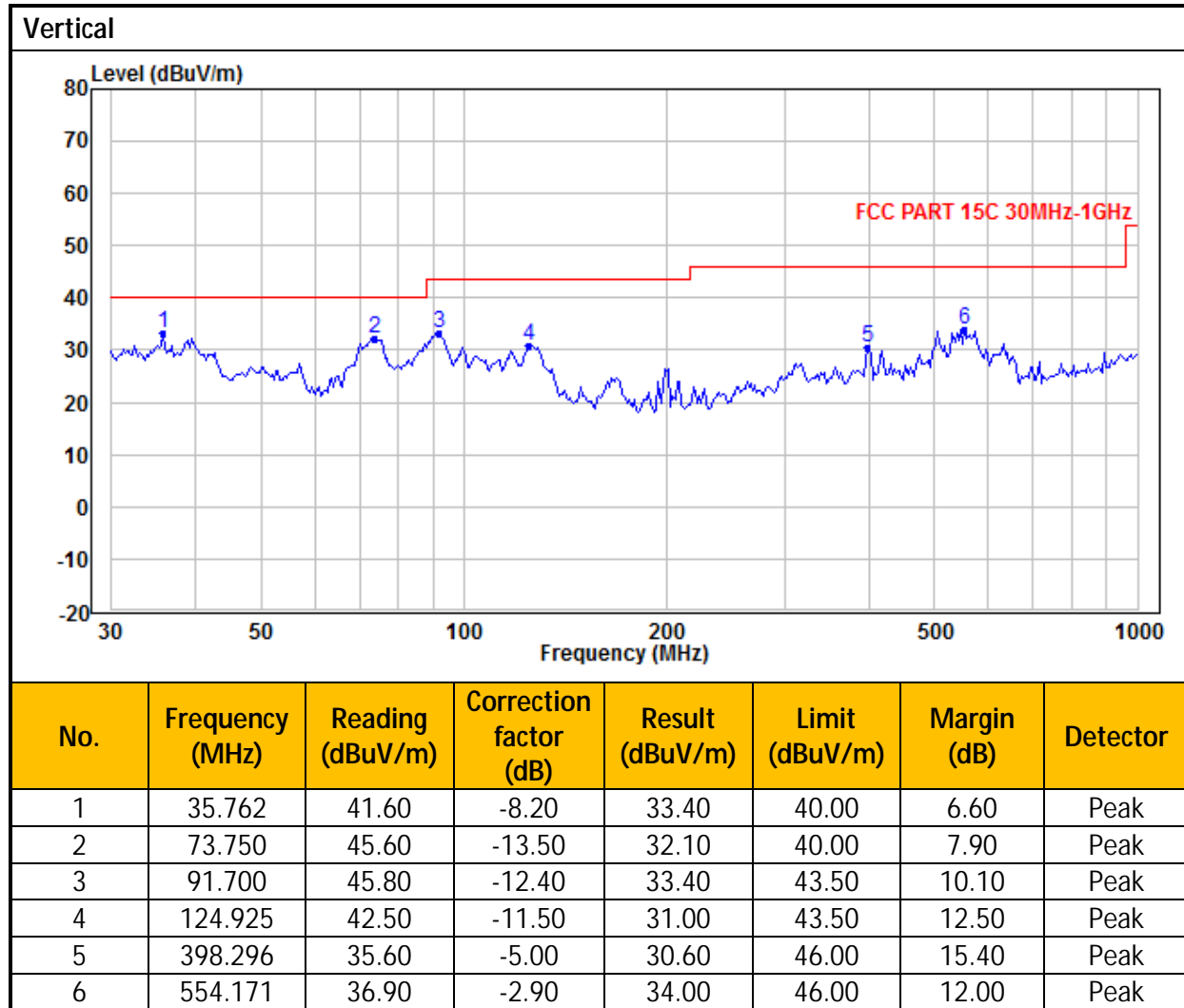

TEST REPORT

Ant. 2_Table 5

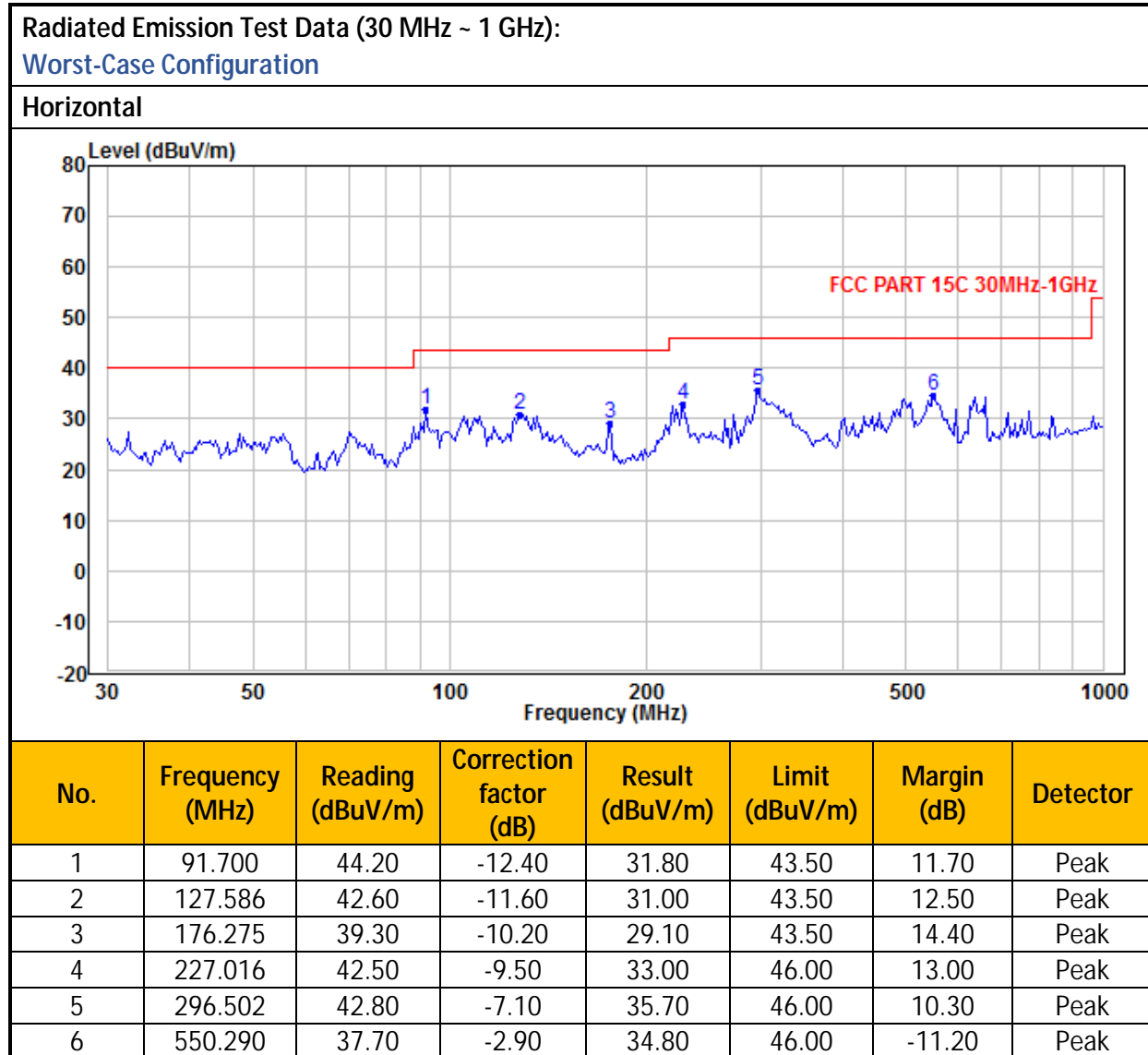

TEST REPORT

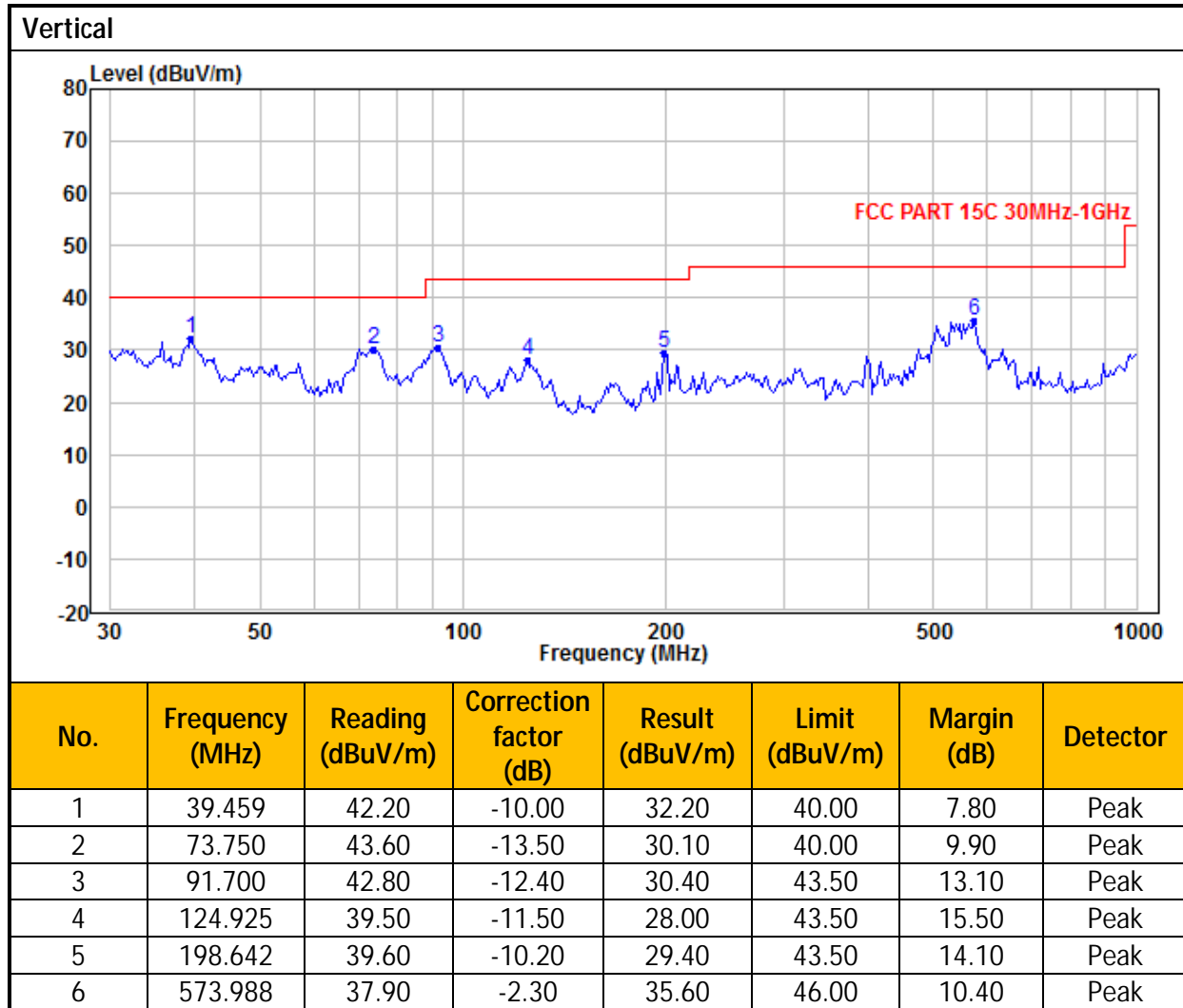

- NOTES:
1. Peak detector is used for the emission measurement.
 2. All measurements were made at 3 meters. Radiated emissions not detected at the 3-meter distance were measured at 0.3-meter and an inverse proportional extrapolation was performed to compare the signal level to the 3-meter limit. No other radiated emissions than those reported were detected at a test distance of 0.3-meter.
 3. Negative value in the margin column shows emission below limit.
 4. Emission (the row indicated by ***bold italic***) within the restricted band meets the requirement of FCC Part 15 Section 15.205.

TEST REPORT

4.6.3 Radiated Emission Test Setup

The figure below shows the test setup, which is utilized to make these measurements.

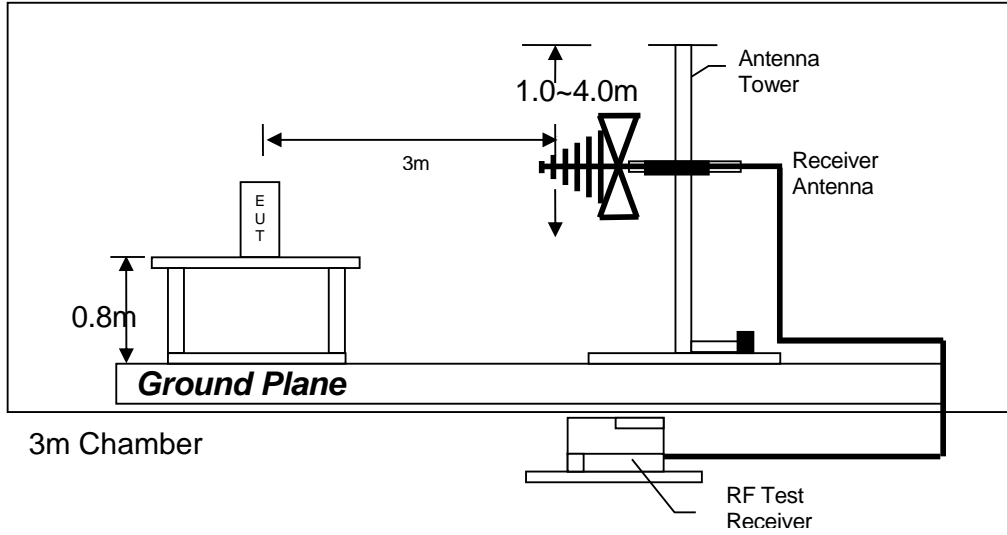

Test setup of radiated emissions up to 1GHz

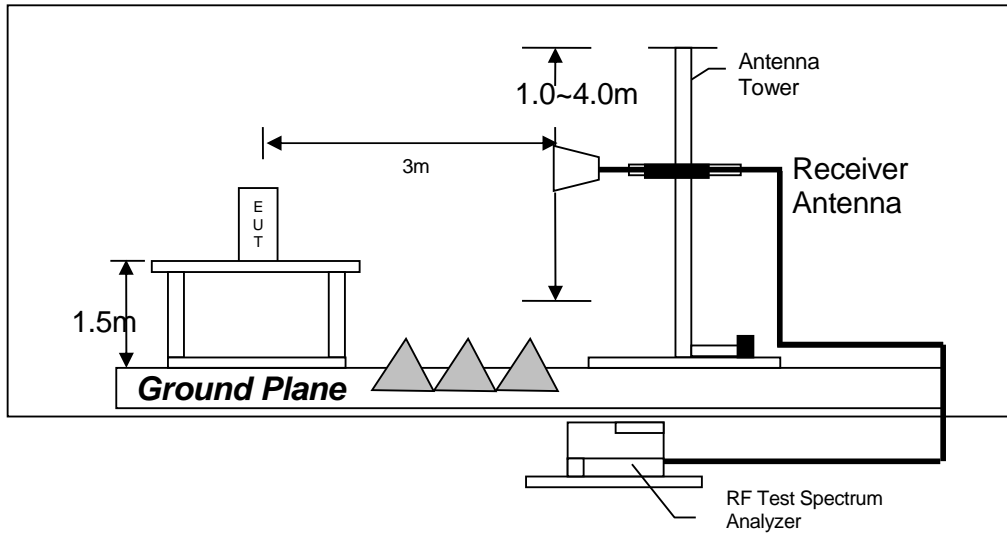

Test setup of radiated emissions above 1GHz

TEST REPORT

4.6.4 Transmitter Duty Cycle Calculation

Not applicable – No average factor is required.

TEST REPORT

4.7 AC Power Line Conducted Emission

- Not applicable – EUT is only powered by battery for operation.
- EUT connects to AC power line. Emission Data is listed in following pages.

- Base Unit connects to AC power line and has transmission. Handset connects to AC power line but has no transmission. Emission Data of Base Unit is listed in following pages.

4.7.1 AC Power Line Conducted Emission Configuration Photograph

Worst Case Line-Conducted Configuration
at

15.013 kHz

The worst case line conducted configuration photographs are attached in the Appendix and saved with filename: config photos.pdf

4.7.2 AC Power Line Conducted Emission Data

The plot(s) and data in the following pages list the significant emission frequencies, the limit and the margin of compliance.

Passed by 8.3 dB margin compare with Quasi-peak limit

TEST REPORT

AC POWER LINE CONDUCTED EMISSION

Worst Case: WiFi Operating

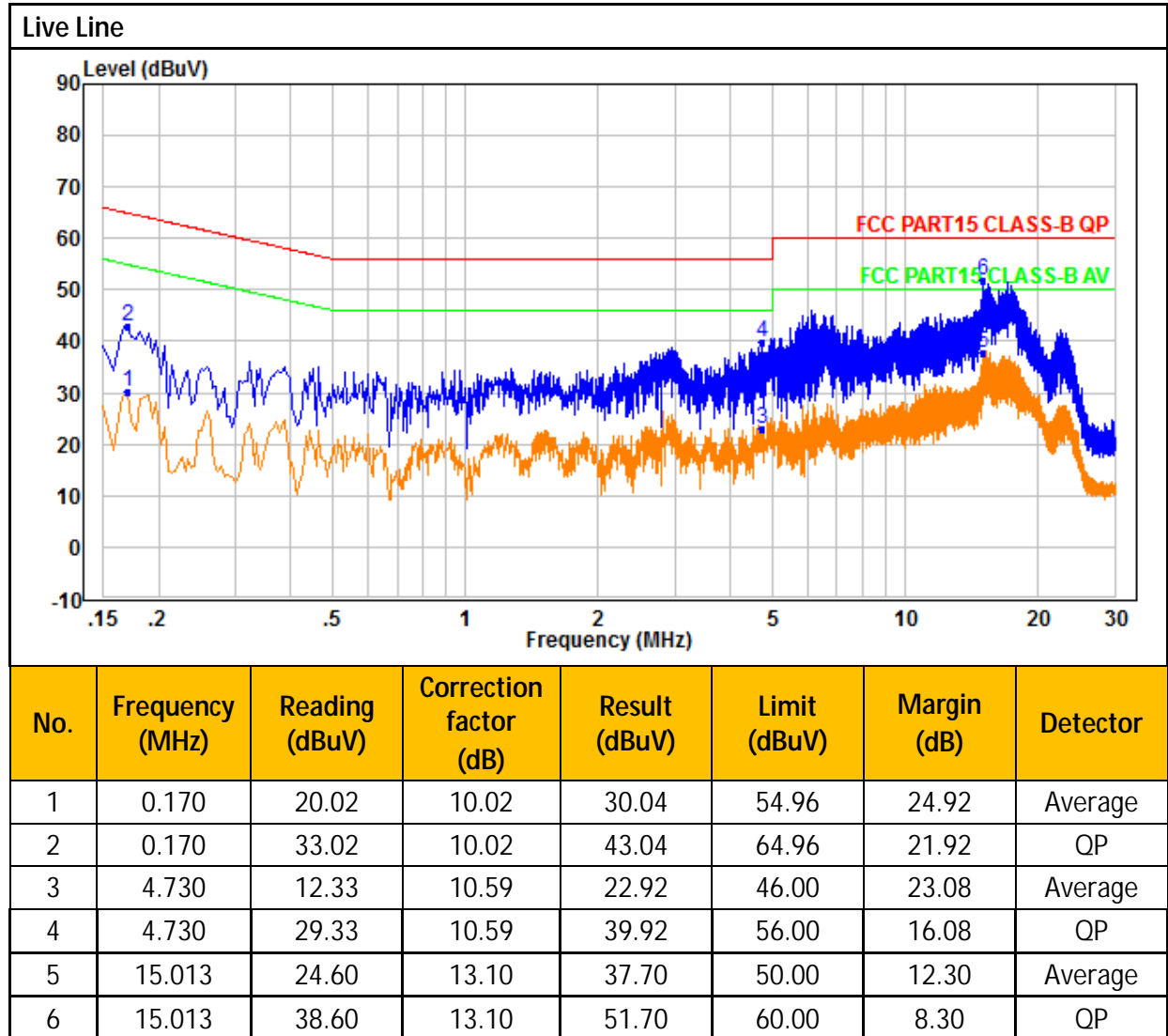

TEST REPORT

Worst Case: WiFi Operating

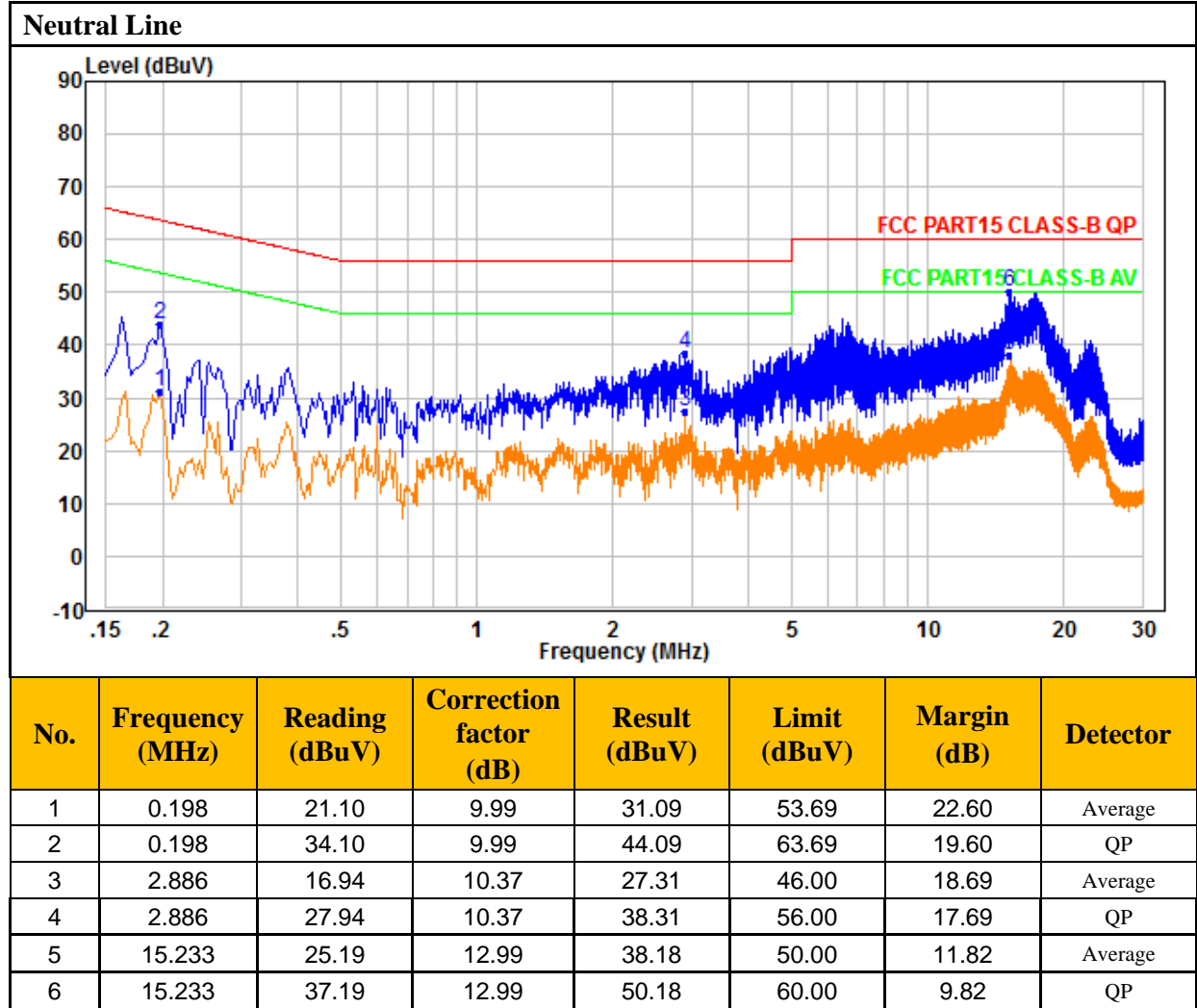

TEST REPORT

4.7.3 Conducted Emission Test Setup

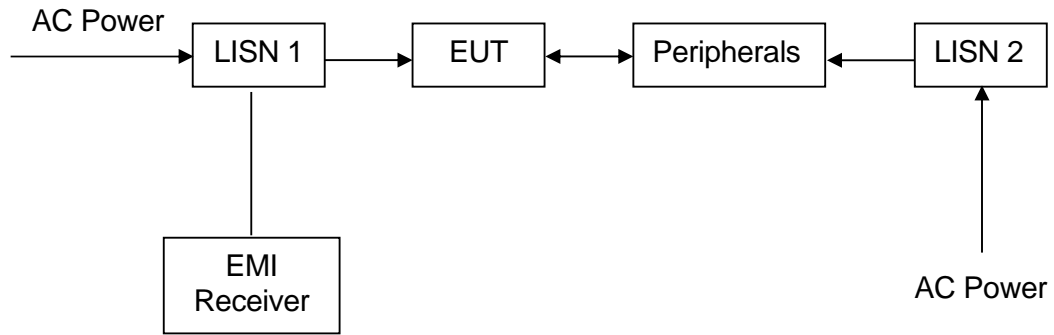

TEST REPORT

5.0 EQUIPMENT LIST

1) Radiated Emissions Test

Used	Registration No.	Equipment	Manufacturer	Model No.	Serial Number	Cal. date (mm dd, yyyy)	Cal. Due date (mm dd, yyyy)
<input checked="" type="checkbox"/>	UTTL-E010	3M Chamber & Accessory Equipment	ETS-LINDGREN	3M	N/A	Dec. 03, 2018	Dec. 03, 2021
<input checked="" type="checkbox"/>	UTTL-E026	Receiver	R&S	ESIB26	100114	Nov. 24, 2018	Nov. 24, 2019
<input checked="" type="checkbox"/>	UTTL-E013	Loop Antenna	ETS-LINDGREN	6502	00202525	Dec. 03, 2018	Dec. 03, 2019
<input checked="" type="checkbox"/>	UTTL-E014	Broadband Antenna	ETS-LINDGREN	3142E	00201566	Dec. 08, 2018	Dec. 08, 2019
<input checked="" type="checkbox"/>	UTTL-E039	6dB Attenuator	Talent	RA6A5-N-18	18103001	Dec. 08, 2018	Dec. 08, 2019
<input checked="" type="checkbox"/>	UTTL-E043	Preamplifier	HP	8447F	2805A02960	Nov. 24, 2018	Nov. 24, 2019
<input checked="" type="checkbox"/>	UTTL-E017	Horn Antenna (Pre-amplifier)	ETS-LINDGREN	3117-PA	00201874	May 22, 2018	May 18, 2020
<input checked="" type="checkbox"/>	N/A	Multi device Controller	ETS-LINDGREN	7006-001	00160105	N/A	N/A
<input checked="" type="checkbox"/>	N/A	Test Software	Audix	e3	Software Version: 9.160333		

2) Conducted Emissions Test

Used	Registration No.	Equipment	Manufacturer	Model No.	Serial Number	Cal. date (mm dd, yyyy)	Cal. Due date (mm dd, yyyy)
<input checked="" type="checkbox"/>	UTTL-E005	Receiver	R&S	ESR7	1316.3003K07-101181-K3	Nov. 24, 2018	Nov. 24, 2019
<input checked="" type="checkbox"/>	UTTL-E007	Pulse Limiter	R&S	ESH3-Z2	0357.8810.54	Nov. 24, 2018	Nov. 24, 2019
<input checked="" type="checkbox"/>	UTTL-E003	LISN	R&S	ESH2-Z5	860014/024	Nov. 24, 2018	Nov. 24, 2019
<input checked="" type="checkbox"/>	N/A	Test Software	Audix	e3	Software Version: 9.160323		

TEST REPORT

3) Conductive Measurement Test

Used	Registration No.	Equipment	Manufacturer	Model No.	Serial Number	Cal. date (mm dd, yyyy)	Cal. Due date (mm dd, yyyy)
<input checked="" type="checkbox"/>	UTTL-E032	EXA Spectrum Analyzer	KEYSIGHT	N9010A	MY51440197	Nov. 24, 2018	Nov. 24, 2019
<input checked="" type="checkbox"/>	UTTL-E033	USB Wideband Power Sensor	KEYSIGHT	U2021XA	MY55430035	Nov. 24, 2018	Nov. 24, 2019

END OF TEST REPORT