

TEST REPORT

Report Number: 19071650HKG-004R1

Application for Original Grant of 47 CFR Part 15 Certification

FCC ID: A2HWT9L10

This report supersedes previous report with report number 19071650HKG-004 dated September 20, 2019.
Please refer HEE-S19-0044 Letter issued on November 05, 2019 for amendment/ supersede notification.

Tested, Prepared and Checked by:

Approved by:



Kelvin Liang
Assistant Manager
Shenzhen UnionTrust Quality and
Technology Co., Ltd.

Lee Shui Tim, Tim
Senior Lead Engineer
Intertek Testing Services Hong Kong
Date: November 05, 2019

Intertek's standard Terms and Conditions can be obtained at our website <http://www.intertek.com/terms/>.

The test report only allows to be revised within the retention period unless further standard or the requirement was noticed.

This report is for the exclusive use of Intertek's Client and is provided pursuant to the agreement between Intertek and its Client. Intertek's responsibility and liability are limited to the terms and conditions of the agreement. Intertek assumes no liability to any party, other than to the Client in accordance with the agreement, for any loss, expense or damage occasioned by the use of this report. Only the Client is authorized to permit copying or distribution of this report and then only in its entirety. Any use of the Intertek name or one of its marks for the sale or advertisement of the tested material, product or service must first be approved in writing by Intertek. The observations and test results in this report are relevant only to the sample tested. This report by itself does not imply that the material, product, or service is or has ever been under an Intertek certification program.

© 2017 Intertek

TEST REPORT

GENERAL INFORMATION

Applicant Name:	Alco Electronics Ltd.
Applicant Address:	11/F., Metropole Square, 2 On Yiu Street, Sha Tin, New Territories, Hong Kong.
FCC Specification Standard:	FCC Part 15, October 1, 2017 Edition
FCC ID:	A2HWT9L10
FCC Model(s):	WT9L10C44GD11, 100002435
Type of EUT:	Spread Spectrum Transmitter
Description of EUT:	Tablet
Serial Number:	N/A
Sample Receipt Date:	July 31, 2019
Date of Test:	August 23, 2019 to September 05, 2019
Report Date:	November 05, 2019
Environmental Conditions:	Temperature: +15 to +35°C Humidity: 20 to 75%
Conclusion:	Test was conducted by client submitted sample. The submitted sample as received complied with the 47 CFR Part 15 Certification.

TEST REPORT

TABLE OF CONTENTS

1.0 TEST RESULTS SUMMARY & STATEMENT OF COMPLIANCE 4

 1.1 Summary of Test Results4

 1.2 Statement of Compliance4

2.0 GENERAL DESCRIPTION 5

 2.1 Product Description.....5

 2.2 Test Methodology5

 2.3 Test Facility5

3.0 SYSTEM TEST CONFIGURATION..... 6

 3.1 Justification6

 3.2 EUT Exercising Software7

 3.3 Details of EUT and Description of Accessories.....8

 3.4 Measurement Uncertainty8

4.0 TEST RESULTS..... 9

 4.1 Maximum Conducted Output Power at Antenna Terminals.....9

 4.2 Maximum 20 dB RF Bandwidth.....12

 4.3 Minimum Number of Hopping Frequencies15

 4.4 Minimum Hopping Channel Carrier Frequency Separation17

 4.5 Average Channel Occupancy Time.....19

 4.6 Out of Band Conducted Emissions21

 4.7 Field Strength Calculation.....27

 4.8 Transmitter Radiated Emissions in Restricted Bands and Spurious Emissions.....28

 4.8.1 Radiated Emission Configuration Photograph29

 4.8.2 Radiated Emission Data29

 4.8.3 Radiated Emission Test Setup30

 4.9 AC Power Line Conducted Emission.....37

 4.9.1 AC Power Line Conducted Emission Configuration Photograph37

 4.9.2 AC Power Line Conducted Emission Data.....37

 4.9.3 AC Line Conducted Emission Test Setup.....40

5.0 EQUIPMENT LIST 41

TEST REPORT

1.0 TEST RESULTS SUMMARY & STATEMENT OF COMPLIANCE

1.1 Summary of Test Results

Test Items	FCC Part 15 Section	Results	Details See Section
Antenna Requirement	15.203	Pass	2.1
Max. Conducted Output Power	15.247(b)(1) & (4)	Pass	4.1
Max. 20dB RF Bandwidth	N/A	N/A	4.2
Min. No. of Hopping Frequencies	15.247(a)(1)(iii)	Pass	4.3
Min. Hopping Channel Carrier Frequency Separation	15.247(a)(1)	Pass	4.4
Average Time of Occupancy	15.247(a)(1)(iii)	Pass	4.5
Out of Band Antenna Conducted Emission	15.247(d)	Pass	4.6
Radiated Emission in Restricted Bands and Spurious Emissions	15.247(d)	Pass	4.8
AC Power Line Conducted Emission	15.207 & 15.107	Pass	4.9

Note: Pursuant to FCC Part 15 Section 15.215(c), the 20dB bandwidth of the emission was contained within the frequency band designated (mentioned as above) which the EUT operated. The effects, if any, from frequency sweeping, frequency hopping, other modulation techniques and frequency stability over expected variations in temperature and supply voltage were considered.

1.2 Statement of Compliance

The equipment under test is found to be complying with the following standards:

FCC Part 15, October 1, 2017 Edition

TEST REPORT

2.0 GENERAL DESCRIPTION

2.1 Product Description

The Tablet WT9L10C44GD11 is a Law enforcement recorder. A wireless mobile phone dock consisting of a base unit and either wireless headset/wireless USB dongle or corded headset.

The Equipment Under Test (EUT) operates at frequency range of 2402MHz to 2480 MHz. There are totally 79 with 1MHz channel separation and 20 active channels out of the 79 channels.

The EUT is power by a battery

The antenna used in the EUT is integral, and the test sample is a prototype.

The Model: 100002435 is the same as the Model: WT9L10C44GD11 in electronics/electrical designs including software & firmware, PCB layout and construction design/physical design/enclosure as declared by client. The only differences between these models are brand name and model number to be sold for marketing purpose as declared by client.

The circuit description and frequency hopping algorithm are attached in the Appendix and saved with filename: descri.pdf.

2.2 Test Methodology

Both AC power line-conducted and radiated emission measurements were performed according to the procedures in ANSI C63.4 (2014). Preliminary radiated scans and all radiated measurements were performed in radiated emission test sites. All Radiated tests were performed at an antenna to EUT distance of 3 meters, unless stated otherwise in the "**Justification Section**" of this Application. Antenna port conducted measurements were performed according to ANSI C63.10 (2013). All other measurements were made in accordance with the procedures in 47 CFR Part 2.

2.3 Test Facility

The radiated emission test site, AC power line conducted measurement facility and antenna port conducted measurement facility used to collect the radiated data, AC Power Line conducted data, and conductive data are at Intertek Testing Services Hong Kong Ltd., which is located at Shenzhen UnionTrust Quality and Technology Co., Ltd. (Address: 16/F, Block A, Building 6, Baoneng Science and Technology Park, Qingxiang Road No.1, Longhua New District, Shenzhen, China). This test facility and site measurement data have been fully placed on file with FCC.

TEST REPORT

3.0 SYSTEM TEST CONFIGURATION

3.1 Justification

For radiated emissions testing, the equipment under test (EUT) was setup to transmit / receive continuously to simplify the measurement methodology. Care was taken to ensure proper power supply voltages during testing. During testing, all cables (if any) were manipulated to produce worst case emissions.

The EUT was powered by a battery.

For the measurements, the EUT was attached to a plastic stand if necessary and placed on the wooden turntable at 0.8m height from the ground plane for emission testing at or below 1GHz and 1.5m for emission measurements above 1GHz. If the base unit attached to peripherals, they were connected and operational (as typical as possible).

The signal was maximized through rotation and placement in the three orthogonal axes. The antenna height and polarization were varied during the search for maximum signal level. The antenna height was varied from 1 to 4 meters. Radiated emissions were taken at three meters unless the signal level was too low for measurement at that distance. If necessary, a pre-amplifier was used and/or the test was conducted at a closer distance.

For any intentional radiator powered by AC power line, measurements of the radiated signal level of the fundamental frequency component of the emission was performed with the supply voltage varied between 85% and 115% of the nominal rated supply voltage.

For transmitter radiated measurement, the spectrum analyzer resolution bandwidth was 100 kHz for frequencies below 1000 MHz. The resolution bandwidth was 1 MHz for frequencies above 1000 MHz.

Radiated emission measurement for transmitter were performed from the lowest radio frequency signal generated in the device which is greater than 9 kHz to the tenth harmonic of the highest fundamental frequency or to 40 GHz, whichever is lower. Receiver was performed from 30MHz to the fifth harmonic of the highest frequency or 40GHz, whichever is lower.

TEST REPORT

3.1 Justification - Cont'd

Emission that are directly caused by digital circuits in the transmit path and transmitter portion were measured, and the limit are according to FCC Part 15 Section 15.209. Digital circuitry used to control additional functions other than the operation of the transmitter is subject to FCC Part Section 15.109 Limits.

Detector function for radiated emissions was in peak mode. Average readings, when required, were taken by measuring the duty cycle of the equipment under test and subtracting the corresponding amount in dB from the measured peak readings. A detailed description for the calculation of the average factor can be found in section 4.3.4.

Determination of pulse desensitization was made according to *Hewlett Packard Application Note 150-2, Spectrum Analysis... Pulsed RF*. The effective period (Teff) was referred to Exhibit 4.3.4. With the resolution bandwidth 1MHz and spectrum analyzer IF bandwidth 3dB, the pulse desensitization factor was 0dB.

For AC line conducted emission test, the EUT along with its peripherals were placed on a 1.0m(W)x1.5m(L) and 0.8m in height wooden table and the EUT was adjusted to maintain a 0.4 meter space from a vertical reference plane. The EUT was connected to power mains through a line impedance stabilization network (LISN), which provided 50ohm coupling impedance for measuring instrument. The LISN housing, measuring instrument case, reference ground plane, and vertical ground plane were bounded together. The excess power cable between the EUT and the LISN was bundled.

All connecting cables of EUT and peripherals were manipulated to find the maximum emission.

All relevant operation modes have been tested, and the worst case data is included in this report.

3.2 EUT Exercising Software

The EUT exercise program used during radiated and conducted testing was designed to exercise the various system components in a manner similar to a typical use.

TEST REPORT

3.3 Details of EUT and Description of Accessories

Details of EUT:

AC adaptor (provided with the unit) was used to power the device. Their description are listed below.

- (1) An AC adaptor (100V to 240V, Model: DBS018A-1201500U) (Provided by Applicant)
- (2) An AC adaptor (100V to 240V, Model: DCT18W120150US-A0) (Provided by Applicant)

Description of Accessories:

- (1) keyboard (Provided by Applicant)

3.4 Measurement Uncertainty

When determining of the test conclusion, the Measurement Uncertainty of test at a level of confidence of 95% has been considered. The values of the Measurement Uncertainty:

No.	Item	Measurement Uncertainty
1	Conducted emission 9KHz-150KHz	±3.8 dB
2	Conducted emission 150KHz-30MHz	±3.4 dB
3	Radiated emission 9KHz-30MHz	±4.9 dB
4	Radiated emission 30MHz-1GHz	±4.7 dB
5	Radiated emission 1GHz-18GHz	±5.1 dB
6	Radiated emission 18GHz-26GHz	±5.2 dB
7	Radiated emission 26GHz-40GHz	±5.2 dB

Uncertainty and Compliance - Unless the standard specifically states that measured values are to be extended by the measurement uncertainty in determining compliance, all compliance determinations are based on the actual measured value.

TEST REPORT

4.0 TEST RESULTS

RF Conducted measurement Test Setup by a Spectrum Analyzer.

The figure below shows the test setup, which is utilized to make these measurements.

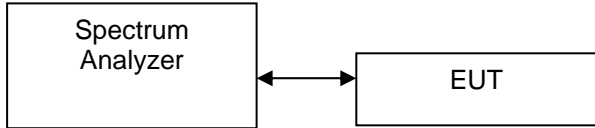

4.1 Maximum Conducted (peak) Output Power at Antenna Terminals

- The antenna power of the EUT was connected to the input of a power meter. Power was read directly and cable loss correction was added to the reading to obtain power at the EUT antenna terminals.
- The antenna port of the EUT was connected to the input of a spectrum analyzer. The analyzer was set for RBW>20dB bandwidth and power was read directly in dBm. External attenuation and cable loss were compensated for using the OFFSET function of the analyzer.

Antenna Gain = -0.1 dBi

Frequency (MHz)	Output in dBm	Output in mWatt
Low Channel: 2402	5.009	2.74
Middle Channel: 2441	4.938	2.75
High Channel: 2480	4.858	2.74

Cable loss : 0.5 dB External Attenuation : 0 dB

Cable loss, external attenuation: included in OFFSET function
 added to SA raw reading

dBm max. output level = 5.0 dBm

Limits:

- 0.125W (21dBm) for antennas with gains of 6dBi or less
- 0.25W (24dBm) for antennas with gains of 6dBi or less
- 1W (30dBm) for antennas with gains of 6dBi or less
- ___W (___dBm) for antennas with gains more than 6dBi

The plots of conducted output power are saved as below.

TEST REPORT

PLOTS OF CONDUCTED OUTPUT POWER

Lowest Channel

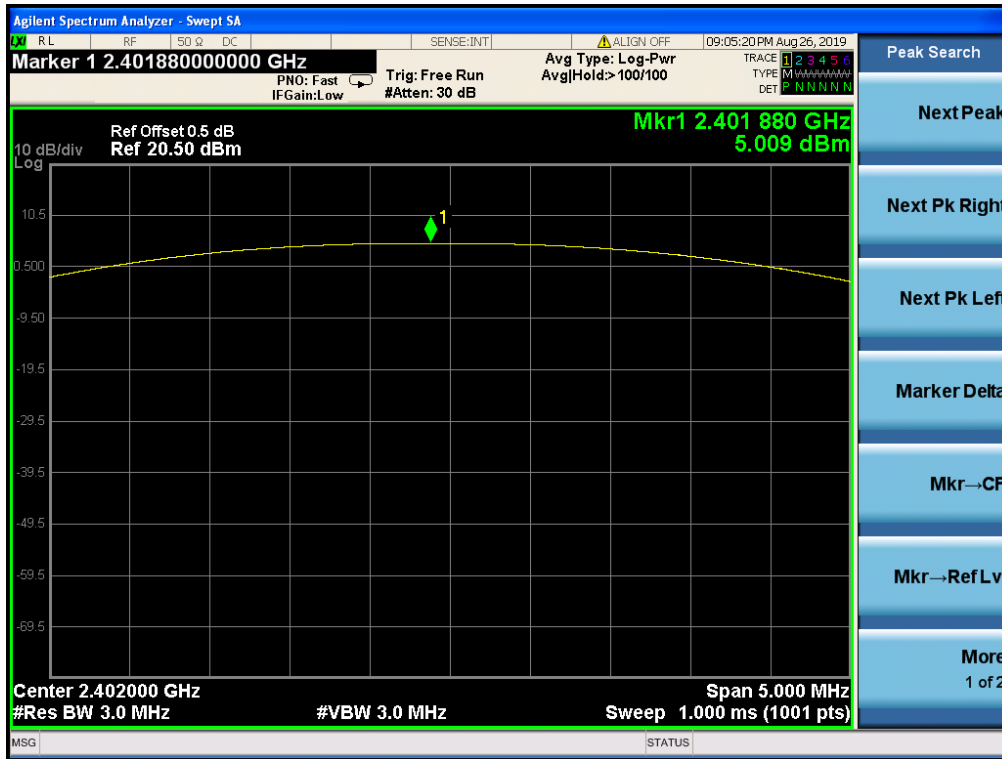

Middle Channel

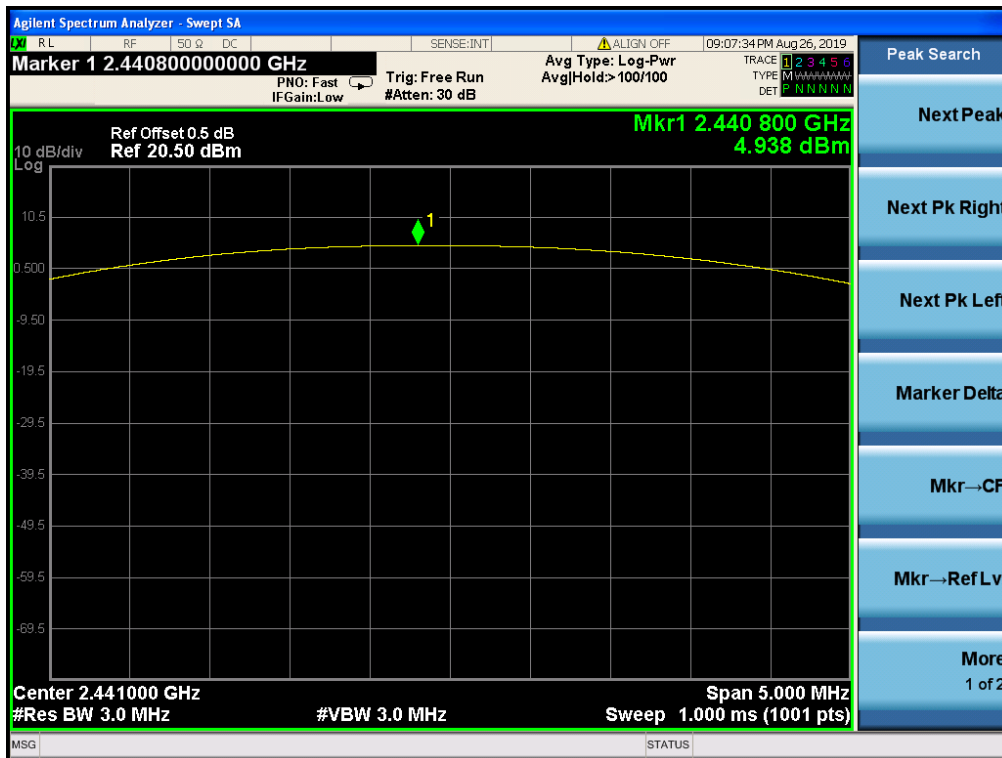

TEST REPORT

PLOTS OF CONDUCTED OUTPUT POWER

Highest Channel

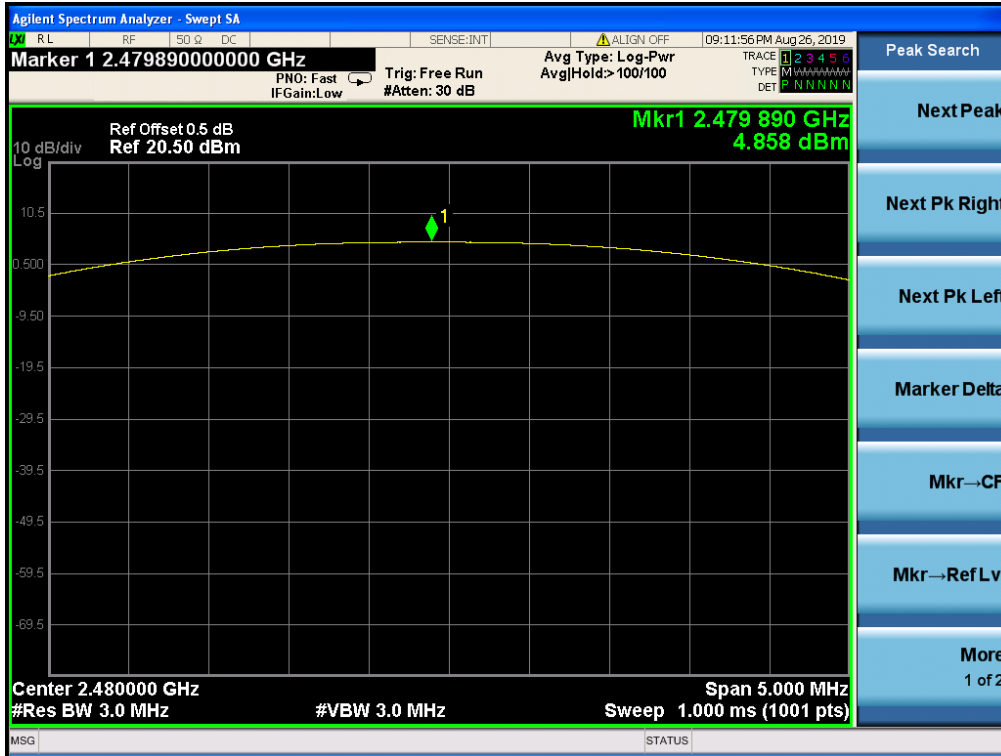

TEST REPORT

4.2 Maximum 20 dB RF Bandwidth

The antenna port of the EUT was connected to the input of a spectrum analyzer. Analyzer RES BW was chosen so that the display was a result of the hopping channel modulation. For each RF output channel investigated, the spectrum analyzer center frequency was set to the channel carrier. A PEAK output reading was taken, a DISPLAY line was drawn 20 dB lower than PEAK level. The 20 dB bandwidth was determined from where the channel output spectrum intersected the display line.

	Frequency (MHz)	20 dB Bandwidth (MHz)(DH5)
Low Channel:	2402	0.9493
Middle Channel:	2441	0.9482
High Channel:	2480	0.9541

Limits

- ≤500kHz for 902-928MHz
- N/A for 2400-2483.5MHz
- ≤1MHz for 5725-5850MHz

The plots of 20dB RF bandwidth are saved as below.

TEST REPORT

PLOTS OF 20dB RF BANDWIDTH

Lowest Channel

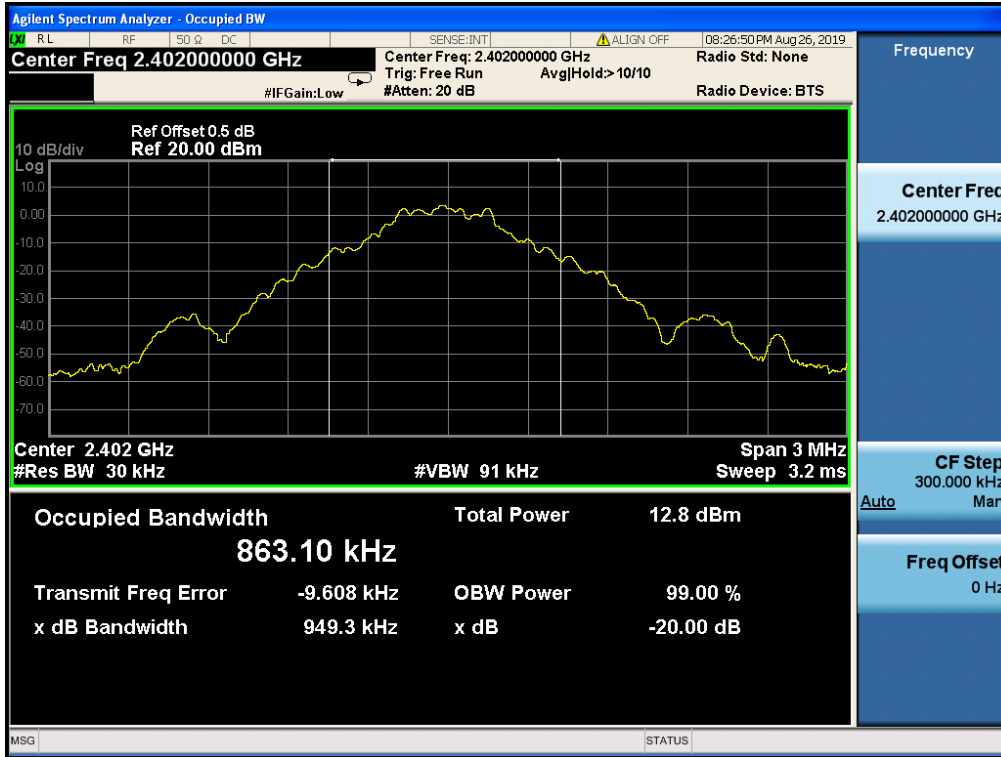

Middle Channel

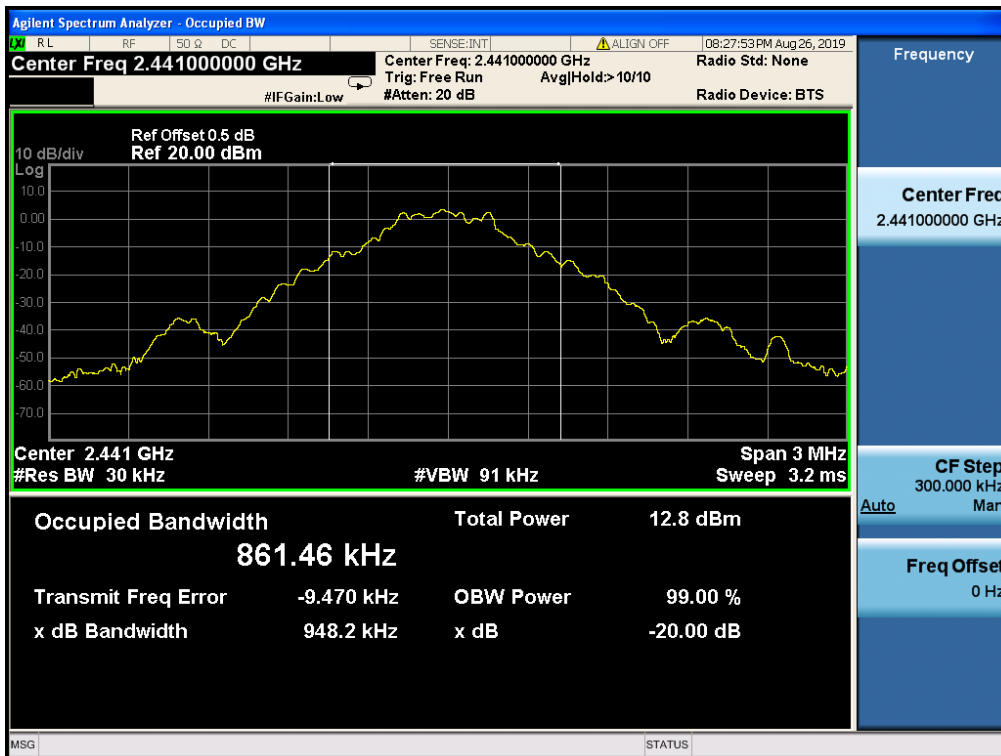

TEST REPORT

PLOTS OF 20dB RF BANDWIDTH

Highest Channel

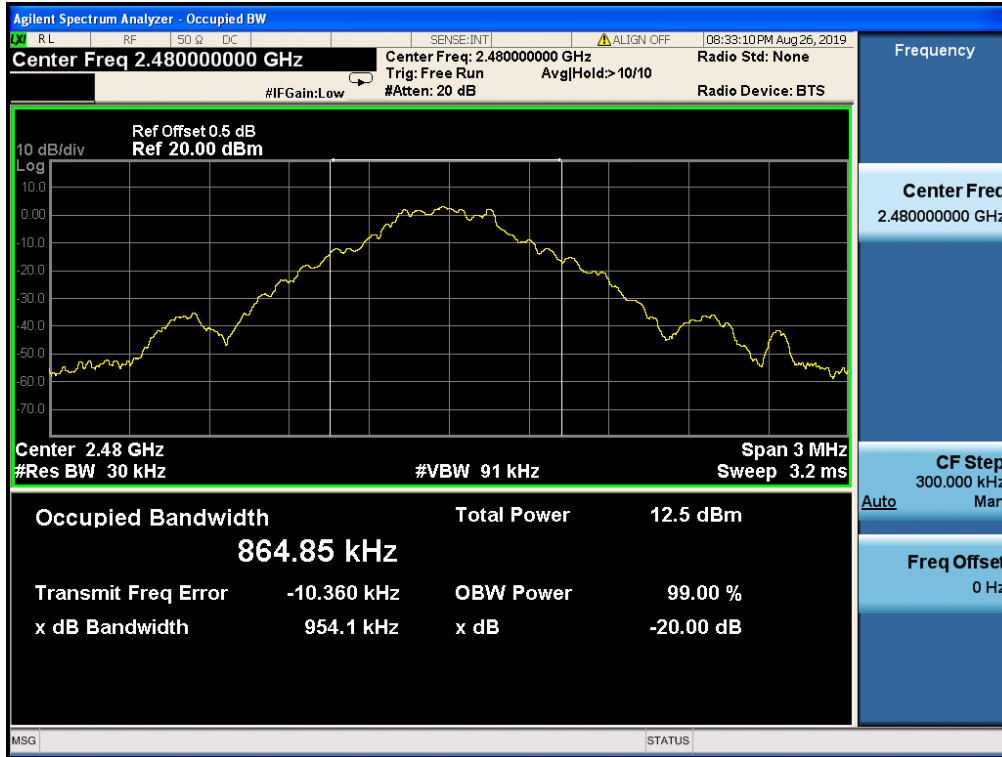

TEST REPORT

4.3 Minimum Number of Hopping Frequencies

With the analyzer set to MAX HOLD readings were taken for 2-3 minutes in each band. The channel peaks so recorded were added together, and the total number compared to the minimum number of channels required in the regulation.

No. of Hopping Channels	79
-------------------------	----

Minimum Requirements:

- at least 50 hopping channels for 902MHz-928MHz (20 dB bandwidth of hopping channel < 250kHz)
- at least 25 hopping channels for 902MHz-928MHz (20 dB bandwidth of hopping channel \geq 250kHz)
- at least 15 hopping channels for 2400MHz-2483.5MHz.
- at least 75 hopping channels for 5725MHz-5850MHz.

The plots of number of hopping frequencies are saved as below.

TEST REPORT

PLOTS OF NUMBER OF HOPPING FREQUENCIES

Plot A

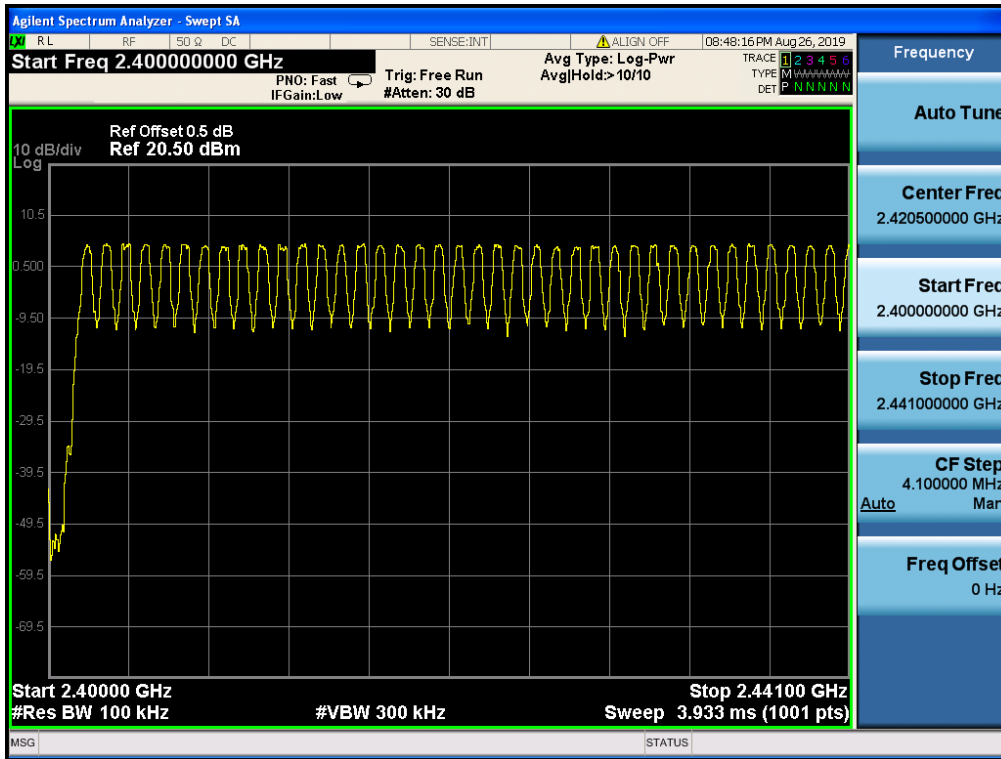

Plot B

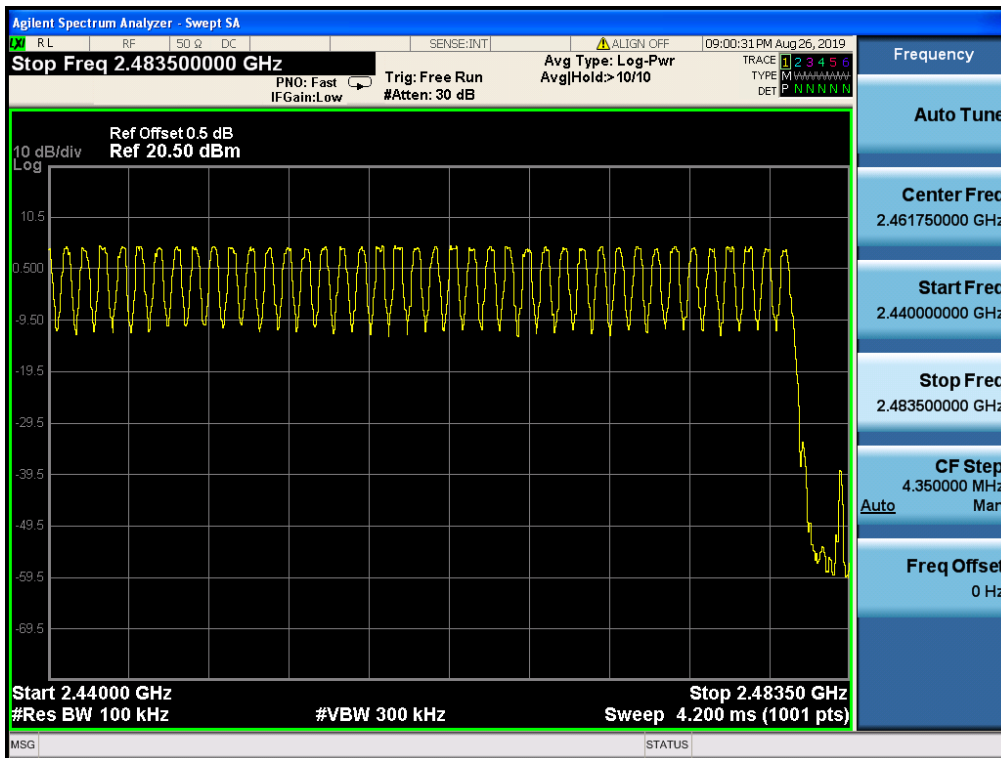

Channels	Limit Min	Limit Max	Result
79	15	---	PASS

TEST REPORT

4.4 Minimum Hopping Channel Carrier Frequency Separation

Using the DELTA MARKER function of the analyzer, the frequency separation between two adjacent channels was measured and met the requirement.

Channel Separation (2441 MHz and 2442 MHz)	1.00 MHz
--	----------

Limits:

The channel separation must be larger than:

- 25 kHz
- 20 dB bandwidth of hopping channel: ___ Hz
- 2/3 of 20dB bandwidth of hopping channel: 640.46 kHz

The plot(s) of hopping channel carrier frequency separation is saved as below.

TEST REPORT

PLOTS OF HOPPING CHANNEL CARRIER FREQUENCY SEPARATION

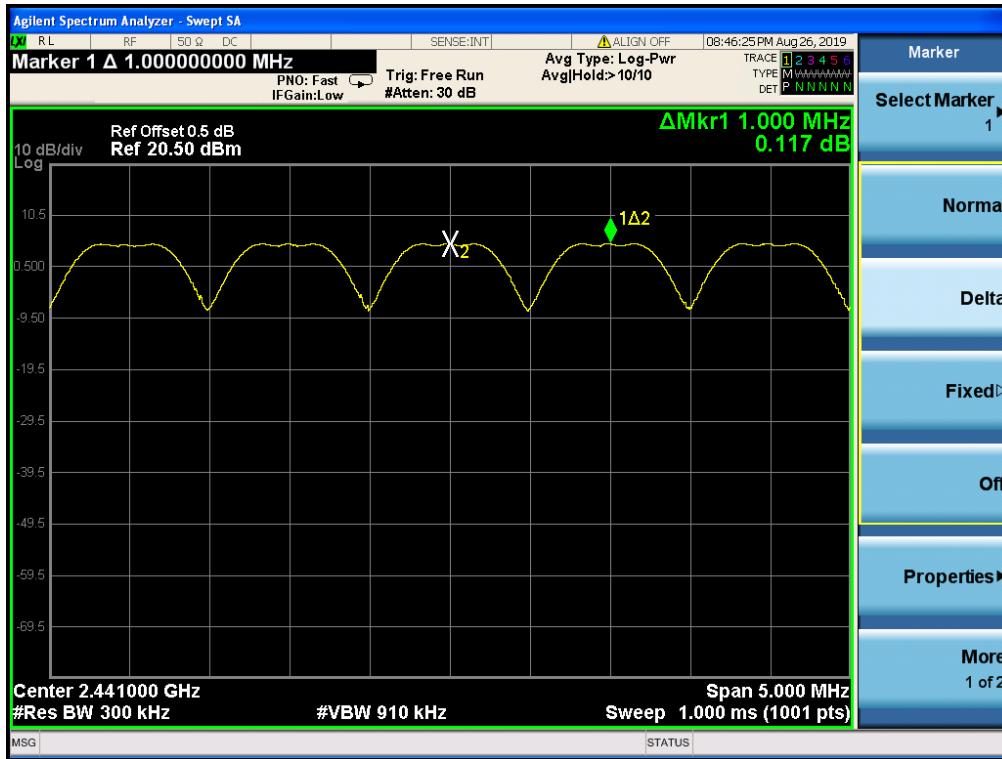

DUT Frequency (MHz)	Frequency Separation (MHz)	Limit Min (MHz)
2441.000000	1.000	0.6321

TEST REPORT

4.5 Average Channel Occupancy Time

The spectrum analyzer center frequency was set to one of the known hopping channels. The SWEEP was set to 1ms, the SPAN was set to ZERO SPAN, and the TRIGGER was set to VIDEO. The time duration of the transmission so captured was measured with the MARKER DELTA function.

The SWEEP was then set to the time required by the regulation (20 seconds for 902-928 MHz devices, if the 20dB bandwidth is less than 250kHz, 10 seconds for 902-928 MHz if the 20dB bandwidth is or greater than 250kHz, "0.4 seconds x Number of hopping channels employed" seconds for 2400-2483.5 MHz, 30 seconds for 5725-5850 MHz). The analyzer was set to SINGLE SWEEP, the total ON time was added and compared against the limit (0.4 seconds).

Average Occupancy Time (Traffic – in a clear RF environment) =	268.026
---	---------

Limits:

Average 0.4 seconds maximum occupancy in:

- 31.6 seconds (0.4 sec. x 79) for 2400MHz-2483.5MHz
(Traffic – in a clear RF environment)
- 20 seconds for 902MHz-928MHz ≥ 50 hopping channels
- 10 seconds for 902MHz-928MHz ≥ 25 hopping channels
- 30 seconds for 5725-5850MHz

The plots of average channel occupancy time are saved as below.

TEST REPORT

PLOTS AVERAGE CHANNEL OCCUPANCY TIME

Plot A

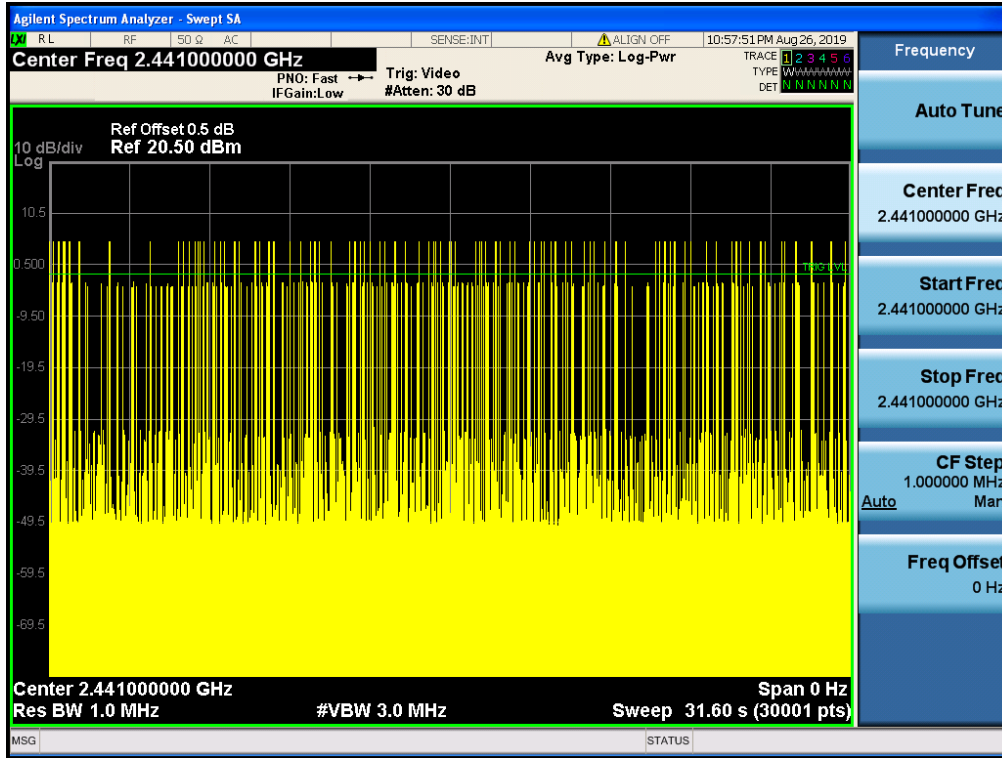

DUT Frequency (MHz)	Time (ms)	Limit Max (ms)	Limit Min (ms)	Threshold (dBm)	Result
2441.000000	268.026	400.000	0.000	-2.0	PASS

TEST REPORT

4.6 Out of Band Conducted Emissions

In any 100 kHz bandwidth outside the EUT passband, the RF power produced by the modulation products of the spreading sequence, the information sequence, and the carrier frequency shall be at least 20 dB below that of the maximum in-band 100 kHz emission.

The plot(s) of bandedge compliance is shown the worst-case which has been already considered between enable and disable the hopping function of the EUT.

Furthermore, delta measurement technique for measuring bandedge emissions was incorporated in the test of the edge at 2483.5MHz.

Limits:

All spurious emission and up to the tenth harmonic was measured and they were found to be at least 20 dB below the highest level of the desired power in the passband.

The plots of out of band conducted emissions are saved as below.

TEST REPORT

PLOTS OF OUT OF BAND CONDUCTED EMISSIONS

Lowest Channel, Plot 1

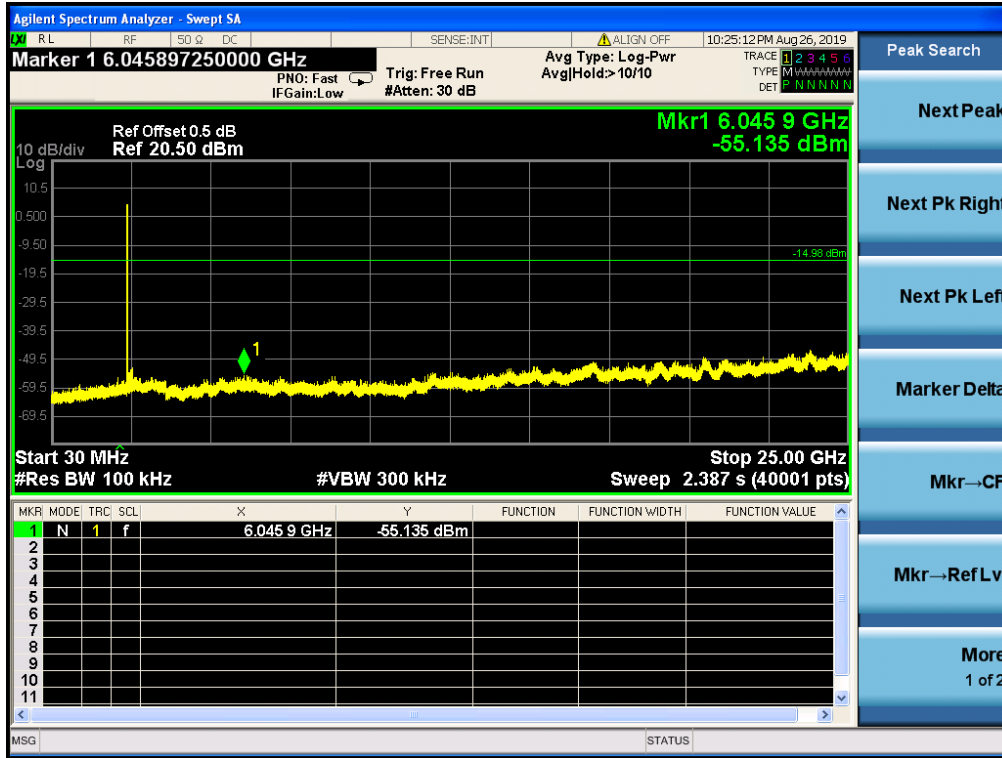

DUT Frequency (MHz)	Result
2402.000000	PASS

TEST REPORT

PLOTS OF OUT OF BAND CONDUCTED EMISSIONS

Middle Channel, Plot 1

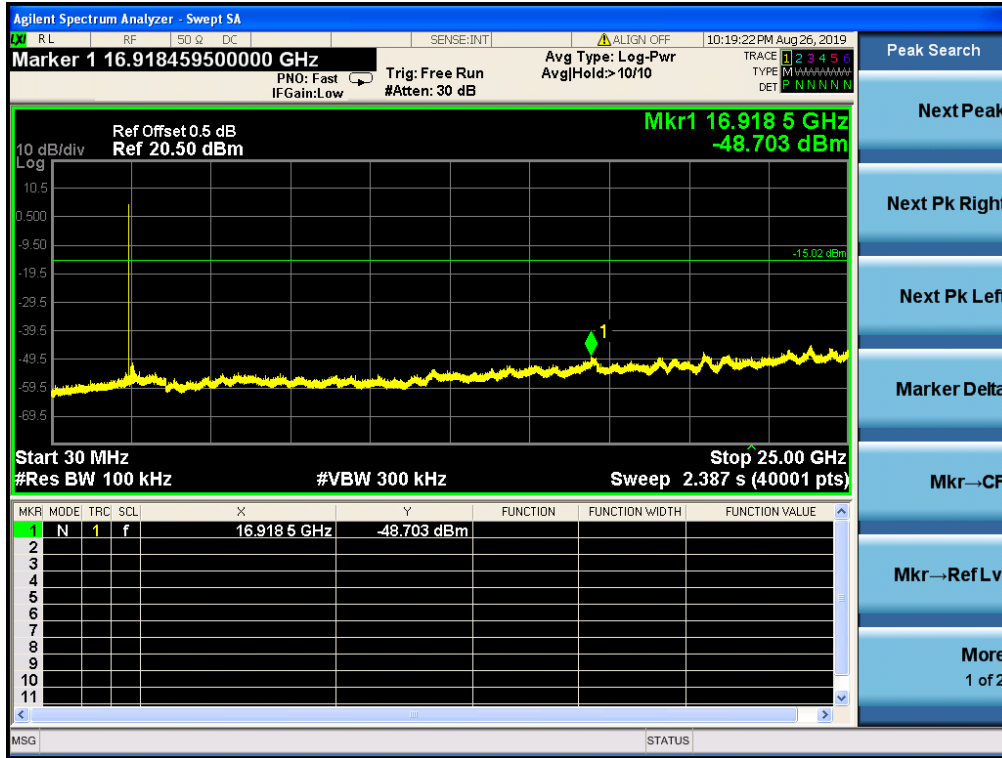

DUT Frequency (MHz)	Result
2441.000000	PASS

TEST REPORT

PLOTS OF OUT OF BAND CONDUCTED EMISSIONS

Highest Channel, Plot 1

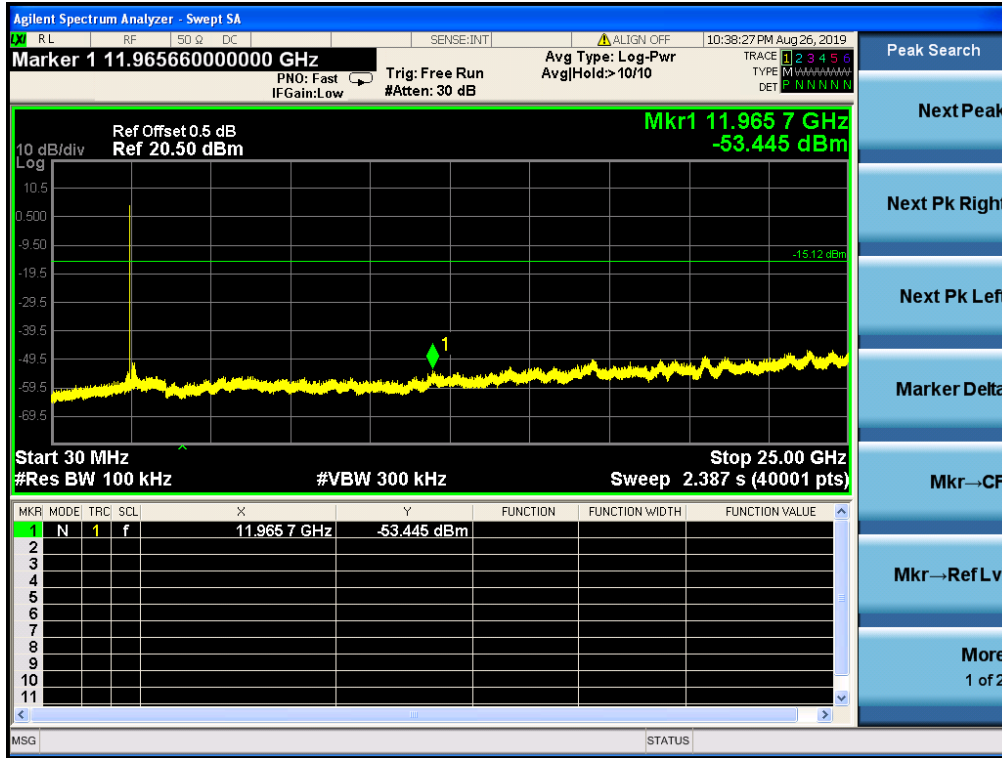

DUT Frequency (MHz)	Result
2480.000000	PASS

TEST REPORT

PLOTS OF BANDEDGE

Lowest Bandedge

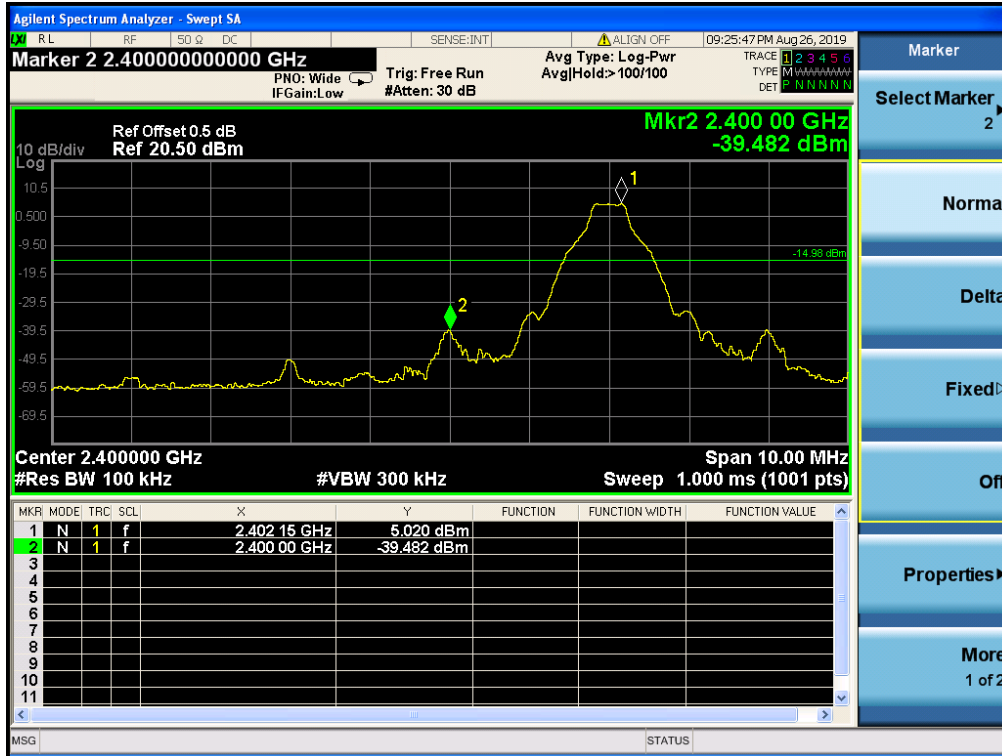

DUT Frequency (MHz)	Result
2402.000000	PASS

TEST REPORT

PLOTS OF BANDEGE

Highest Bandedge



DUT Frequency (MHz)	Result
2480.000000	PASS

TEST REPORT

4.7 Field Strength Calculation

The field strength is calculated by adding the reading on the Spectrum Analyzer to the factors associated with preamplifiers (if any), antennas, cables, pulse desensitization and average factors (when specified limit is in average and measurements are made with peak detectors). A sample calculation is included below.

$$FS = RA + AF + CF - AG + PD + AV$$

where

- FS = Field Strength in dB μ V/m
- RA = Receiver Amplitude (including preamplifier) in dB μ V
- CF = Cable Attenuation Factor in dB
- AF = Antenna Factor in dB
- AG = Amplifier Gain in dB
- PD = Pulse Desensitization in dB
- AV = Average Factor in -dB

In the radiated emission table which follows, the reading shown on the data table may reflect the preamplifier gain. An example of the calculations, where the reading does not reflect the preamplifier gain, follows:

$$FS = RA + AF + CF - AG + PD + AV$$

Example

Assume a receiver reading of 62.0 dB μ V is obtained. The antenna factor of 7.4 dB and cable factor of 1.6 dB is added. The amplifier gain of 29 dB is subtracted. The pulse desensitization factor of the spectrum analyzer was 0 dB, and the resultant average factor was -10 dB. The net field strength for comparison to the appropriate emission limit is 32 dB μ V/m. This value in dB μ V/m was converted to its corresponding level in μ V/m.

$$\begin{aligned} RA &= 62.0 \text{ dB}\mu\text{V} \\ AF &= 7.4 \text{ dB} \\ CF &= 1.6 \text{ dB} \\ AG &= 29 \text{ dB} \\ PD &= 0 \text{ dB} \\ AV &= -10 \text{ dB} \\ FS &= 62 + 7.4 + 1.6 - 29 + 0 + (-10) = 32 \text{ dB}\mu\text{V/m} \end{aligned}$$

$$\text{Level in } \mu\text{V/m} = \text{Common Antilogarithm } [(32 \text{ dB}\mu\text{V/m})/20] = 39.8 \mu\text{V/m}$$

TEST REPORT

4.8 Transmitter Radiated Emissions in Restricted Bands and Spurious Emissions

Data is included of the worst case configuration (the configuration which resulted in the highest emission levels). A sample calculation, configuration photographs and data tables of the emissions are included.

The data on the following pages list the significant emission frequencies, the limit and the margin of compliance.

TEST REPORT

4.8.1 Radiated Emission Configuration Photograph

Worst Case Restricted Band Radiated Emission
at

71.203 MHz

The worst case radiated emission configuration photographs are attached in the Appendix and saved with filename: config photos.pdf

4.8.2 Radiated Emission Data

The data in tables 1-4 list the significant emission frequencies, the limit and the margin of compliance.

Judgement -

Passed by 7.7 dB

TEST REPORT

4.8.3 Radiated Emission Test Setup

The figure below shows the test setup, which is utilized to make these measurements.

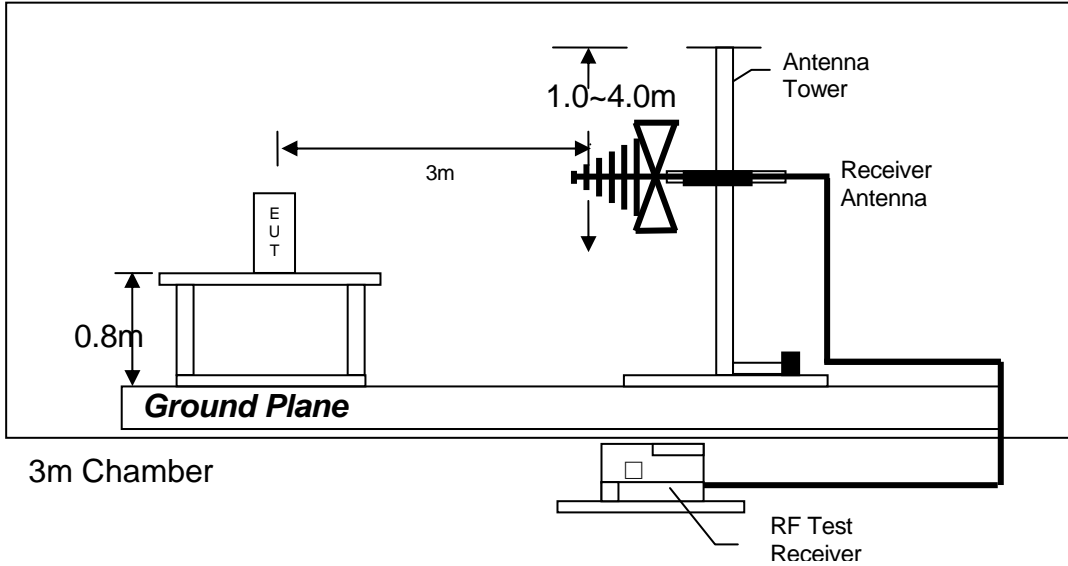

Test setup of radiated emissions up to 1GHz

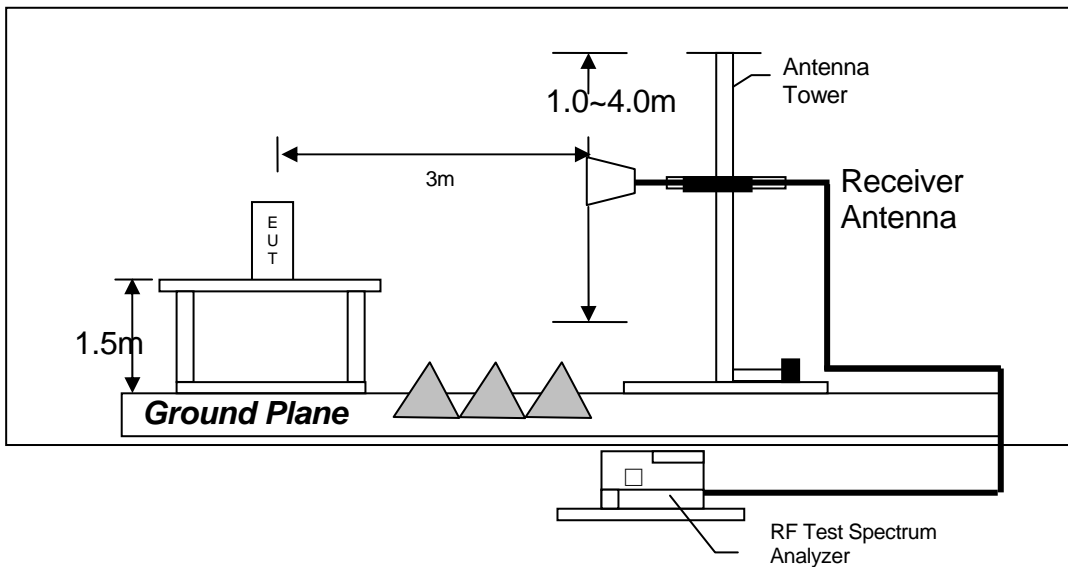

Test setup of radiated emissions above 1GHz

TEST REPORT

RADIATED EMISSION DATA

Mode: TX-2402MHz

Table 1

Radiated Emission Test Data (Above 1GHz):
Lowest Channel:

No.	Frequency (MHz)	Reading (dBuV/m)	Correction factor (dB)	Result (dBuV/m)	Limit (dBuV/m)	Margin (dB)	Detector	Antenna Polaxis
1	4804.00	33.6	3.9	37.5	74.0	36.5	Peak	Horizontal
2	4804.00	22.6	3.9	26.5	54.0	27.5	Average	Horizontal
3	7206.00	37.2	6.8	44.0	74.0	30.1	Peak	Horizontal
4	7206.00	25.8	6.8	32.6	54.0	21.4	Average	Horizontal
5	4804.00	33.8	4.9	38.8	74.0	35.2	Peak	Vertical
6	4804.00	22.7	4.9	27.7	54.0	26.4	Average	Vertical
7	7206.00	36.8	6.3	43.1	74.0	30.9	Peak	Vertical
8	7206.00	25.9	6.3	32.2	54.0	21.8	Average	Vertical

Middle Channel:

No.	Frequency (MHz)	Reading (dBuV/m)	Correction factor (dB)	Result (dBuV/m)	Limit (dBuV/m)	Margin (dB)	Detector	Antenna Polaxis
1	4882.00	36.2	1.9	38.1	74.0	35.9	Peak	Horizontal
2	4882.00	24.5	1.9	26.4	54.0	27.6	Average	Horizontal
3	7323.00	38.4	5.5	43.9	74.0	30.1	Peak	Horizontal
4	7323.00	27.5	5.5	33.0	54.0	21.1	Average	Horizontal
5	4882.00	35.2	5.0	40.2	74.0	33.8	Peak	Vertical
6	4882.00	23.1	5.0	28.1	54.0	25.9	Average	Vertical
7	7323.00	37.3	6.5	43.8	74.0	30.2	Peak	Vertical
8	7323.00	26.3	6.5	32.8	54.0	21.2	Average	Vertical

Highest Channel:

No.	Frequency (MHz)	Reading (dBuV/m)	Correction factor (dB)	Result (dBuV/m)	Limit (dBuV/m)	Margin (dB)	Detector	Antenna Polaxis
1	4960.00	35.6	2.4	38.0	74.0	36.0	Peak	Horizontal
2	4960.00	23.8	2.4	26.2	54.0	27.8	Average	Horizontal
3	7440.00	37.9	7.0	44.9	74.0	29.2	Peak	Horizontal
4	7440.00	26.2	7.0	33.1	54.0	20.9	Average	Horizontal
5	4960.00	37.5	2.0	39.5	74.0	34.5	Peak	Vertical
6	4960.00	26.5	2.0	28.5	54.0	25.5	Average	Vertical
7	7440.00	38.2	7.1	45.3	74.0	28.7	Peak	Vertical
8	7440.00	25.8	7.1	32.9	54.0	21.1	Average	Vertical

TEST REPORT

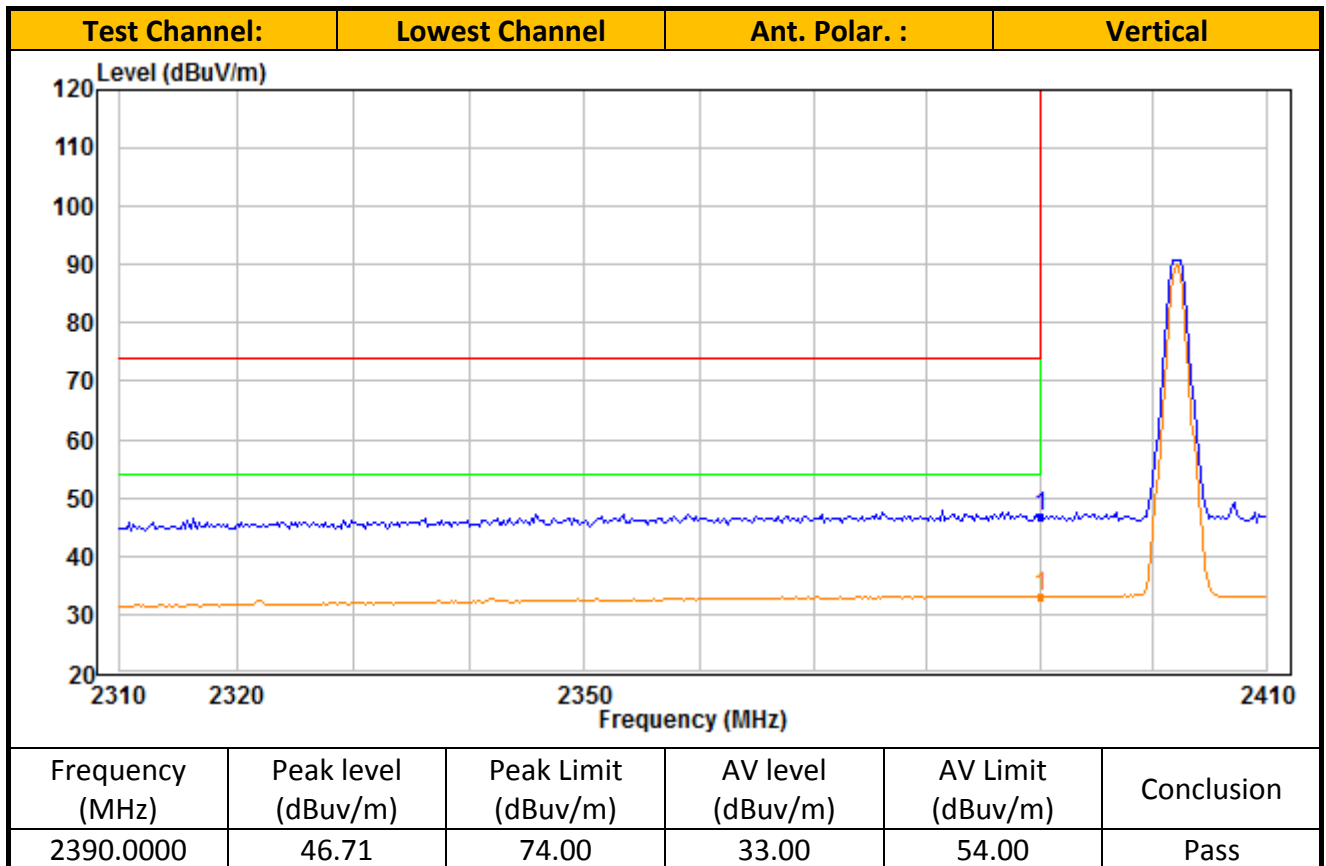
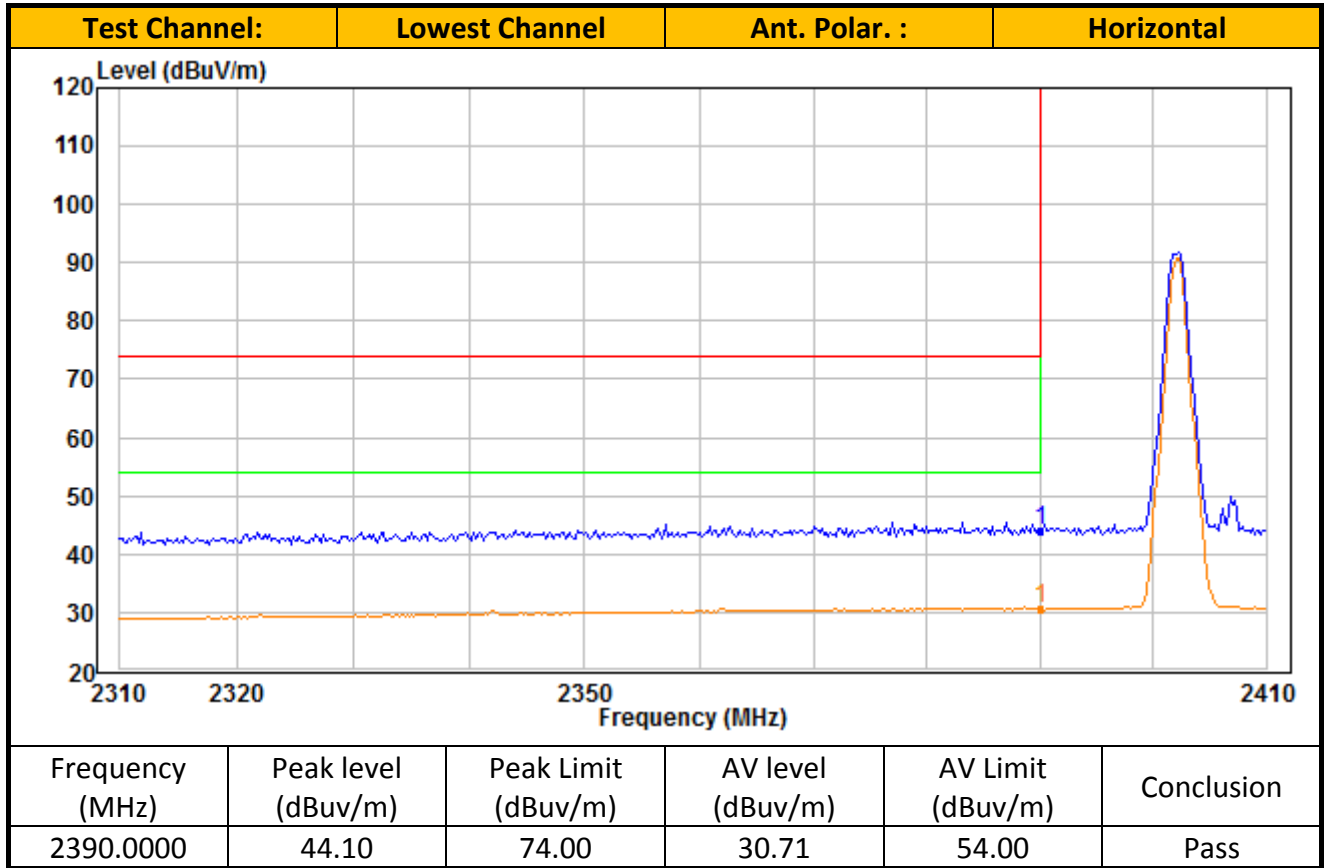

TEST REPORT

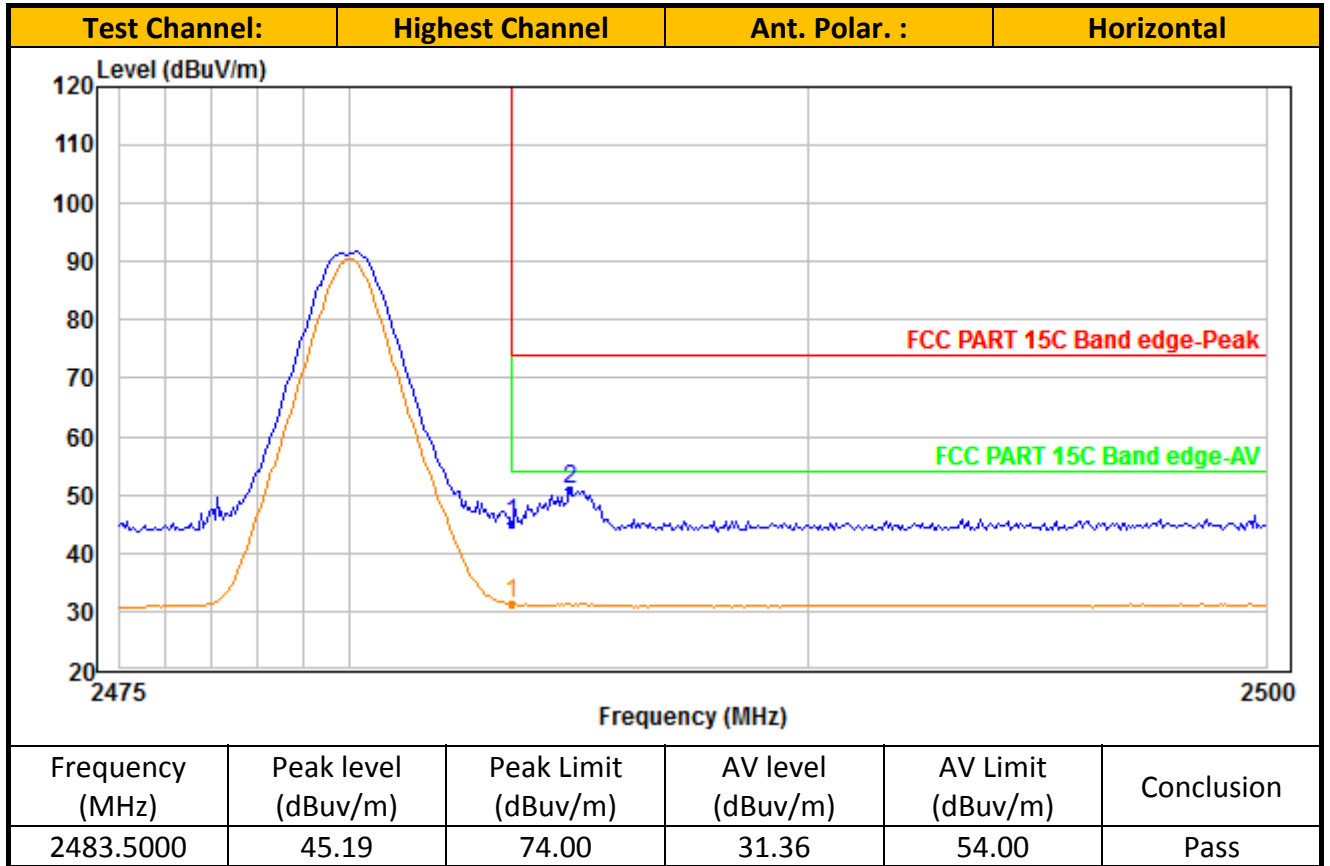

TEST REPORT

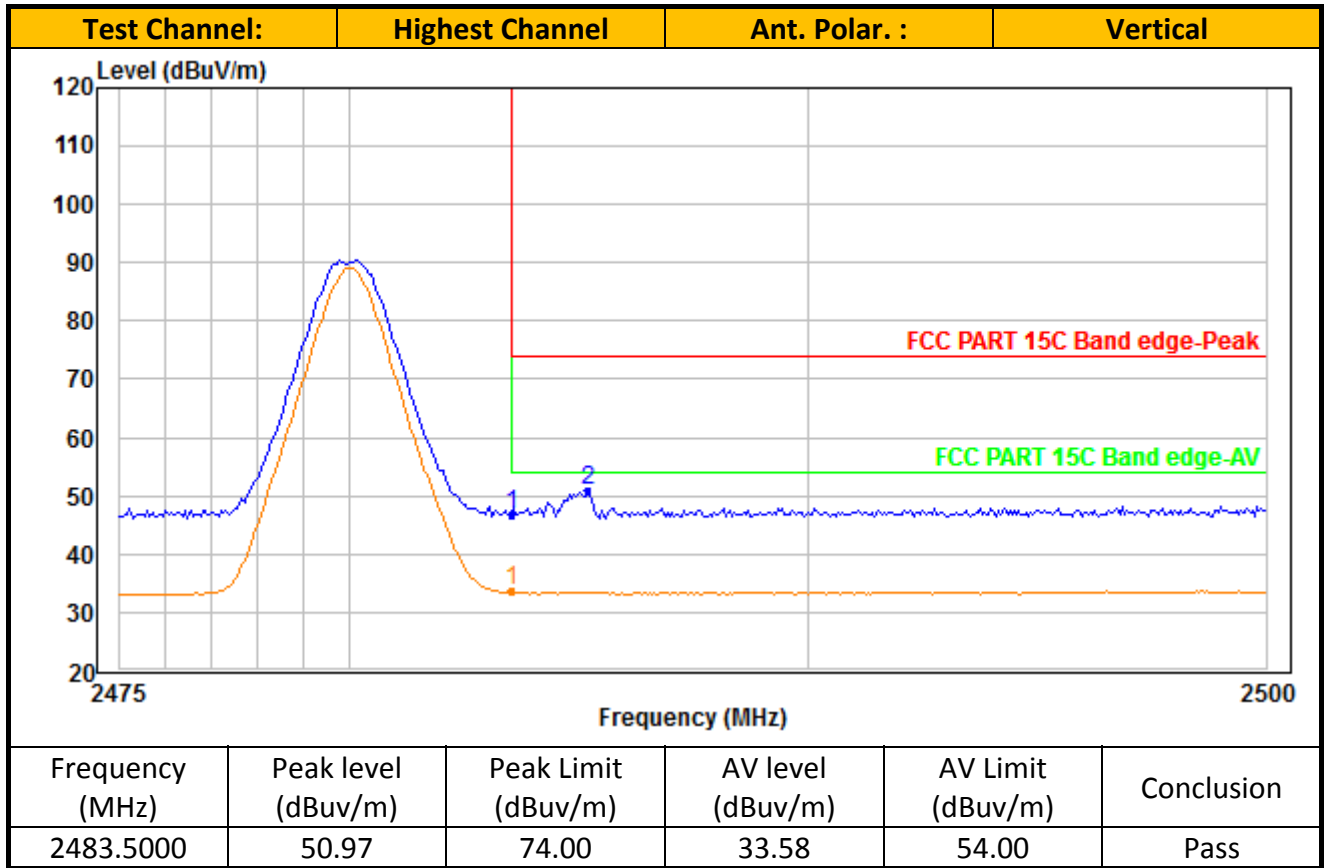

- NOTES:
1. Peak detector is used for the emission measurement.
 2. All measurements were made at 3 meters. Radiated emissions not detected at the 3-meter distance were measured at 0.3-meter and an inverse proportional extrapolation was performed to compare the signal level to the 3-meter limit. No other radiated emissions than those reported were detected at a test distance of 0.3-meter.
 3. Negative value in the margin column shows emission below limit.
 4. Horn antenna is used for the emission over 1000MHz.
 5. Emission (the row indicated by ***bold italic***) within the restricted band meets the requirement of FCC Part 15 Section 15.205.

TEST REPORT

Mode: On

Table 2

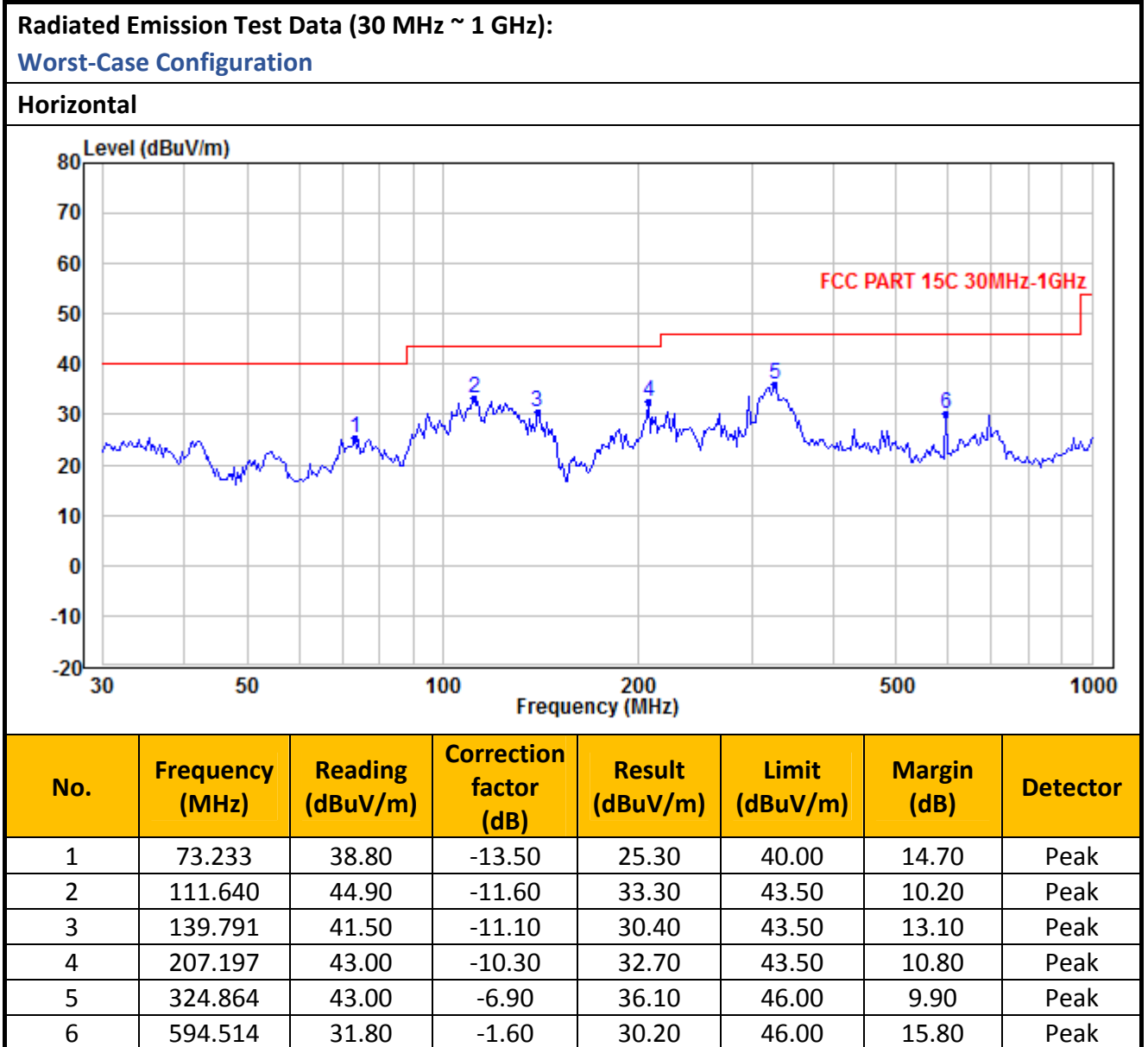

TEST REPORT

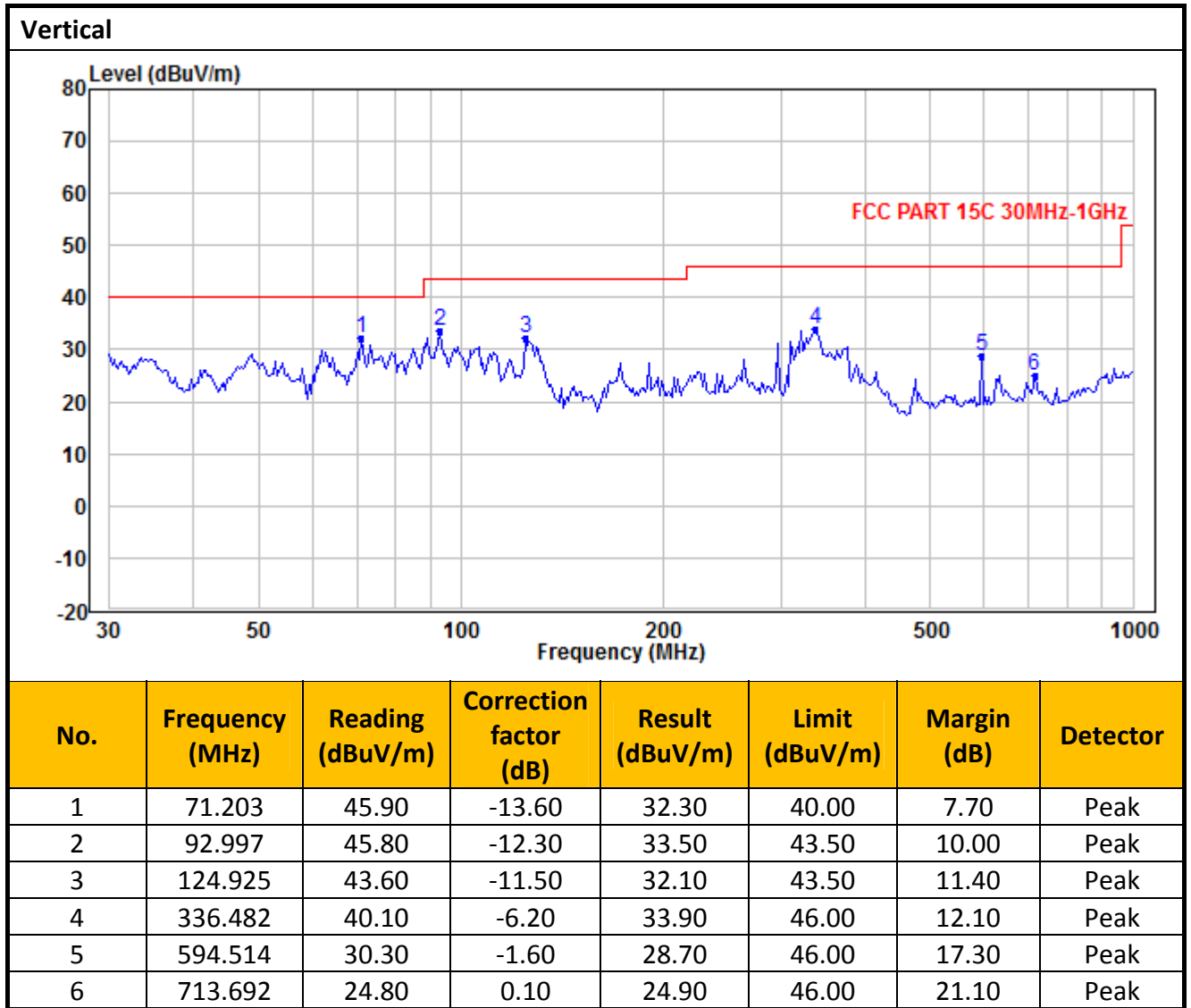

- NOTES:
1. Peak detector is used for the emission measurement.
 2. All measurements were made at 3 meters. Radiated emissions not detected at the 3-meter distance were measured at 0.3-meter and an inverse proportional extrapolation was performed to compare the signal level to the 3-meter limit. No other radiated emissions than those reported were detected at a test distance of 0.3-meter.
 3. Negative value in the margin column shows emission below limit.
 4. Horn antenna is used for the emission over 1000MHz.
 5. Emission (the row indicated by ***bold italic***) within the restricted band meets the requirement of FCC Part 15 Section 15.205.
 6. Measurement Uncertainty is ± 5.3 dB at a level of confidence of 95%.

TEST REPORT

4.9 AC Power Line Conducted Emission

- Not applicable – EUT is only powered by battery for operation.
- EUT connects to AC power line. Emission Data is listed in following pages.
- Base Unit connects to AC power line and has transmission. Handset connects to AC power line but has no transmission. Emission Data of Base Unit is listed in following pages.

4.9.1 AC Power Line Conducted Emission Configuration Photograph

Worst Case Line-Conducted Configuration
at

17.277 MHz

The worst case line conducted configuration photographs are attached in the Appendix and saved with filename: config photos.pdf

4.9.2 AC Power Line Conducted Emission Data

The plot(s) and data in the following pages list the significant emission frequencies, the limit and the margin of compliance.

Passed by 3.23 dB margin compare with Quasi-peak limit

TEST REPORT

AC POWER LINE CONDUCTED EMISSION

Worst Case: Bluetooth on mode with full load

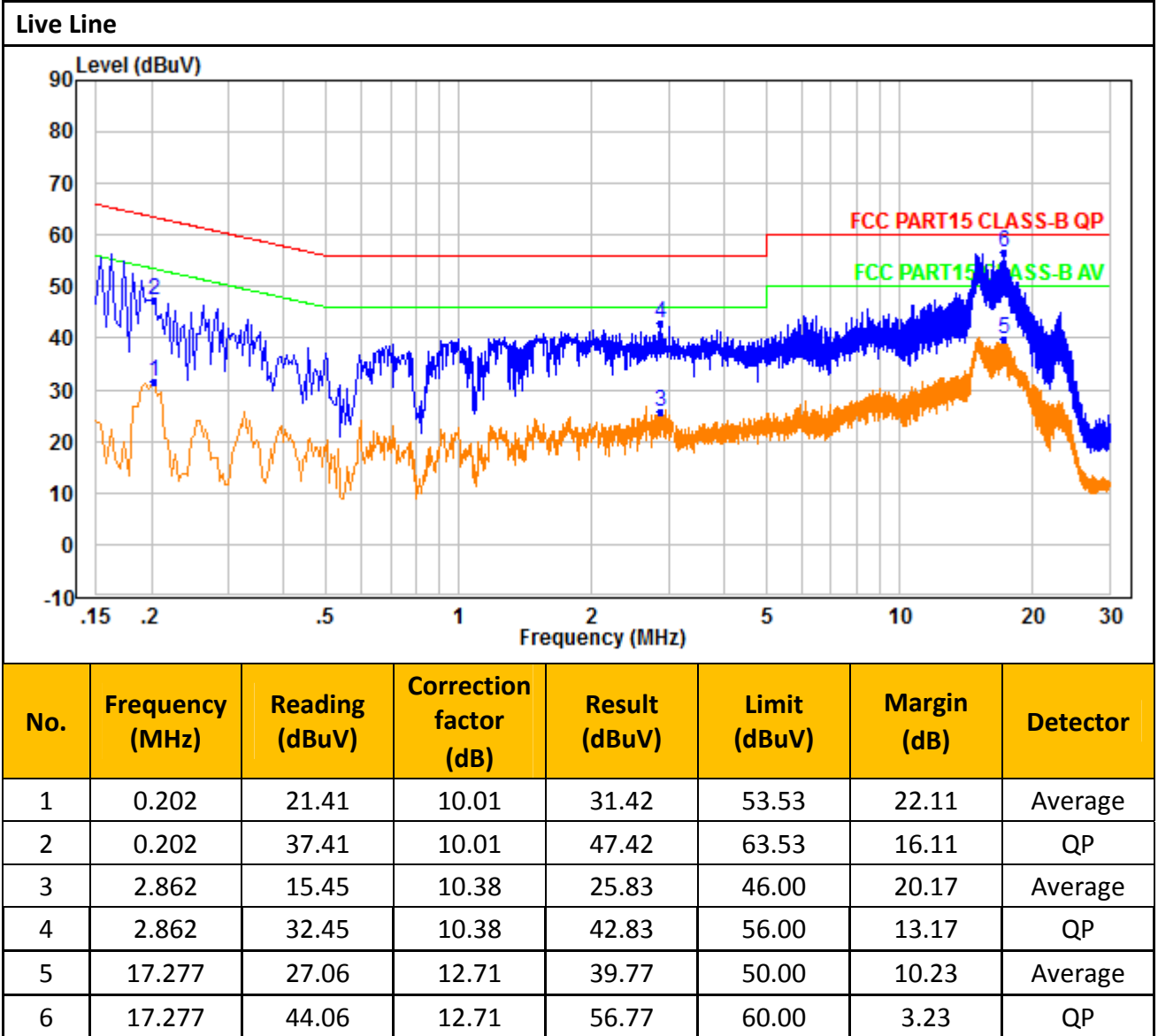

TEST REPORT

Worst Case: Bluetooth on mode with full load

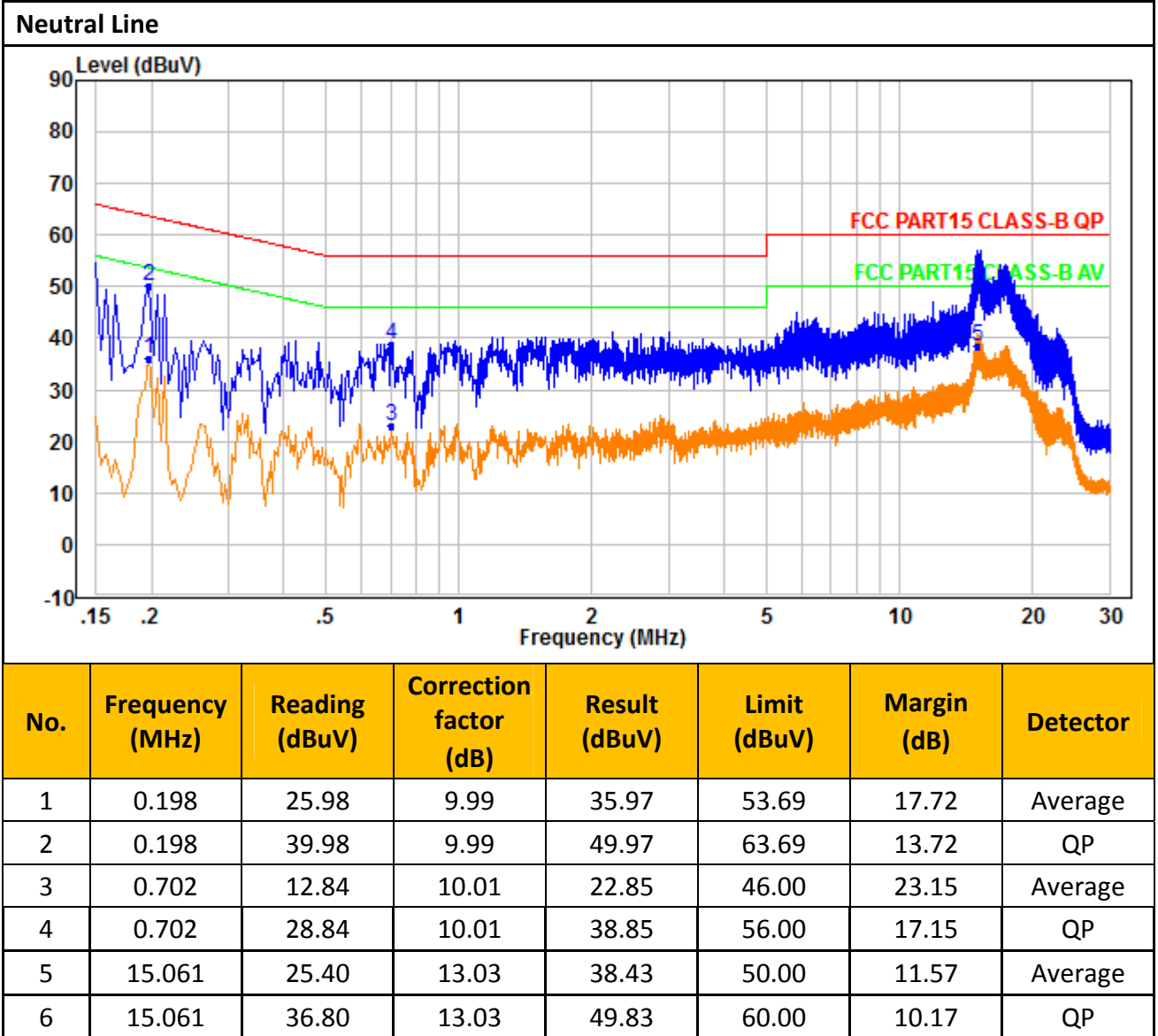

TEST REPORT

4.9.3 AC Line Conducted Emission Test Setup

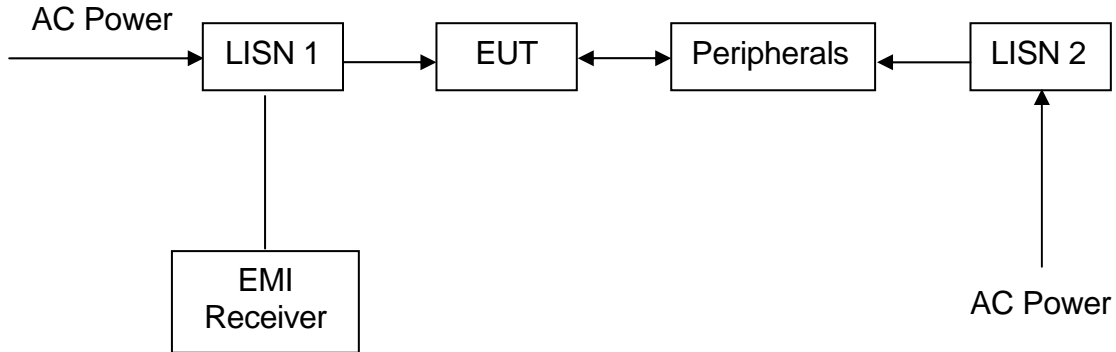

The EUT along with its peripherals were placed on a 1.0m(W)×1.5m(L) and 0.8m in height wooden table and the EUT was adjusted to maintain a 0.4 meter space from a vertical reference plane. The EUT was connected to power mains through a line impedance stabilization network (LISN), which provided 50 ohm coupling impedance for measuring instrument and the chassis ground was bounded to the horizontal ground plane of shielded room. The excess power cable between the EUT and the LISN was bundled.

All connecting cables of EUT and peripherals were moved to find the maximum emission.

TEST REPORT

5.0 EQUIPMENT LIST

1) Radiated Emissions Test

Used	Registration No.	Equipment	Manufacturer	Model No.	Serial Number	Cal. date (mm dd, yyyy)	Cal. Due date (mm dd, yyyy)
<input checked="" type="checkbox"/>	UTTL-E010	3M Chamber & Accessory Equipment	ETS-LINDGREN	3M	N/A	Dec. 03, 2018	Dec. 03, 2021
<input checked="" type="checkbox"/>	UTTL-E026	Receiver	R&S	ESIB26	100114	Nov. 24, 2018	Nov. 24, 2019
<input checked="" type="checkbox"/>	UTTL-E013	Loop Antenna	ETS-LINDGREN	6502	00202525	Dec. 03, 2018	Dec. 03, 2019
<input checked="" type="checkbox"/>	UTTL-E014	Broadband Antenna	ETS-LINDGREN	3142E	00201566	Dec. 08, 2018	Dec. 08, 2019
<input checked="" type="checkbox"/>	UTTL-E039	6dB Attenuator	Talent	RA6A5-N-18	18103001	Dec. 08, 2018	Dec. 08, 2019
<input checked="" type="checkbox"/>	UTTL-E043	Preamplifier	HP	8447F	2805A02960	Nov. 24, 2018	Nov. 24, 2019
<input checked="" type="checkbox"/>	UTTL-E017	Horn Antenna (Pre-amplifier)	ETS-LINDGREN	3117-PA	00201874	May 22, 2018	May 18, 2020
<input checked="" type="checkbox"/>	N/A	Multi device Controller	ETS-LINDGREN	7006-001	00160105	N/A	N/A
<input checked="" type="checkbox"/>	N/A	Test Software	Audix	e3	Software Version: 9.160333		

2) Conducted Emissions Test

Used	Registration No.	Equipment	Manufacturer	Model No.	Serial Number	Cal. date (mm dd, yyyy)	Cal. Due date (mm dd, yyyy)
<input checked="" type="checkbox"/>	UTTL-E005	Receiver	R&S	ESR7	1316.3003K07-101181-K3	Nov. 24, 2018	Nov. 24, 2019
<input checked="" type="checkbox"/>	UTTL-E007	Pulse Limiter	R&S	ESH3-Z2	0357.8810.54	Nov. 24, 2018	Nov. 24, 2019
<input checked="" type="checkbox"/>	UTTL-E003	LISN	R&S	ESH2-Z5	860014/024	Nov. 24, 2018	Nov. 24, 2019
<input checked="" type="checkbox"/>	N/A	Test Software	Audix	e3	Software Version: 9.160323		

TEST REPORT

3) Conductive Measurement Test

Used	Registration No.	Equipment	Manufacturer	Model No.	Serial Number	Cal. date (mm dd, yyyy)	Cal. Due date (mm dd, yyyy)
<input checked="" type="checkbox"/>	UTTL-E032	EXA Spectrum Analyzer	KEYSIGHT	N9010A	MY51440197	Nov. 24, 2018	Nov. 24, 2019
<input checked="" type="checkbox"/>	UTTL-E033	USB Wideband Power Sensor	KEYSIGHT	U2021XA	MY55430035	Nov. 24, 2018	Nov. 24, 2019

END OF TEST REPORT