



Valued Quality. Delivered.

## TEST REPORT

**Report No.: 16050240HKG-003**

**Alco Electronics Ltd**

Application  
For  
Certification  
(Original Grant)  
**(FCC ID: A2HW1013)**  
**(IC: 9903A-W1013)**

Transceiver

This report contains the data of Bluetooth portion only.

Prepared and Checked by:

Approved by:

Signed On File  
Wong Cheuk Ho, Herbert  
Lead Engineer

---

Koo Wai Ip  
Assistant Supervisor  
Date: October 25, 2016

- Intertek's standard Terms and Conditions can be obtained at our website <http://www.intertek.com/terms/>.
- The test report only allows to be revised within the retention period unless further standard or the requirement was noticed.
- This report is for the exclusive use of Intertek's Client and is provided pursuant to the agreement between Intertek and its Client. Intertek's responsibility and liability are limited to the terms and conditions of the agreement. Intertek assumes no liability to any party, other than to the Client in accordance with the agreement, for any loss, expense or damage occasioned by the use of this report. Only the Client is authorized to permit copying or distribution of this report and then only in its entirety. Any use of the Intertek name or one of its marks for the sale or advertisement of the tested material, product or service must first be approved in writing by Intertek. The observations and test results in this report are relevant only to the sample tested. This report by itself does not imply that the material, product, or service is or has ever been under an Intertek certification program.
- © 2016 Intertek

**Intertek Testing Services Hong Kong Ltd.**

2/F., Garment Centre, 576 Castle Peak Road, Kowloon, Hong Kong.  
Tel: (852) 2173 8888 Fax: (852) 2785 5487 Website: [www.hk.intertek-etlsemko.com](http://www.hk.intertek-etlsemko.com)

---

## INTERTEK TESTING SERVICES

---

### GENERAL INFORMATION

Grantee:	Alco Electronics Ltd
Grantee Address:	11/F., Zung Fu Industrial Building, 1067 King's Road, Quarry Bay, Hong Kong.
Contact Person:	Peggy Suen
Tel:	(852) 2562 6121
Fax:	(852) 2597 5201
e-mail:	peggy.suen@alco.com.hk
Manufacturer:	Alco Electronics (Dongguan) Limited
Manufacturer Address:	Gong Ye Xi Road, Houjie Technology Industrial Park, Houjie, Dongguan, Guangdong P.R.C. 523960 China
Brand Name:	VENTURER / RCA
FCC Model:	WT19503W / W1013, W101 V2
For IC HVIN:	WT19503W / W1013, W101 V2
For IC PMN:	WT19503W / W1013, W101 V2
Type of EUT:	Transceiver
Description of EUT:	Tablet
Serial Number:	N/A
FCC ID / IC:	A2HW1013 / 9903A-W1013
Date of Sample Submitted:	May 04, 2016
Date of Test:	May 04, 2016 to September 05, 2016
Report No.:	16050240HKG-003
Report Date:	October 25, 2016
Environmental Conditions:	Temperature: +10 to 40°C Humidity: 10 to 90%

---

---

## INTERTEK TESTING SERVICES

---

---

### SUMMARY OF TEST RESULT

TEST SPECIFICATION	REFERENCE	RESULTS
Transmitter Power Line Conducted Emissions	15.207 / RSS-Gen 8.8	Pass
Radiated Emission Radiated Emission on the Bandedge	15.249, 15.209 / RSS-210 A2.9, RSS-210 2.5	Pass
Radiated Emission in Restricted Bands	15.205 / RSS-210 2.2	Pass

The equipment under test is found to be complying with the following standards:  
FCC Part 15, October 1, 2014 Edition  
RSS-210 Issue 8, December 2010  
RSS-Gen Issue 4, November 2014

- Note: 1. The EUT uses a permanently attached antenna which, in accordance to section 15.203, is considered sufficient to comply with the provisions of this section.
2. Pursuant to FCC part 15 Section 15.215(c), the 20 dB bandwidth of the emission was contained within the frequency band designated (mentioned as above) which the EUT operated. The effects, if any, from frequency sweeping, frequency hopping, other modulation techniques and frequency stability over excepted variations in temperature and supply voltage were considered.

---

# INTERTEK TESTING SERVICES

---

## Table of Contents

1.0	<b><u>General Description</u></b> .....	1
1.1	Product Description .....	1
1.2	Related Submittal(s) Grants .....	2
1.3	Test Methodology .....	2
1.4	Test Facility .....	2
2.0	<b><u>System Test Configuration</u></b> .....	3
2.1	Justification.....	3
2.2	EUT Exercising Software .....	5
2.3	Special Accessories.....	5
2.4	Measurement Uncertainty .....	5
2.5	Support Equipment List and Description.....	5
3.0	<b><u>Emission Results</u></b> .....	6
3.1	Field Strength Calculation .....	6
3.2	Radiated Emission Configuration Photograph .....	7
3.3	Radiated Emission Data .....	7
3.4	Conducted Emission Configuration Photograph .....	7
3.5	Conducted Emission Data.....	7
4.0	<b><u>Equipment Photographs</u></b> .....	17
5.0	<b><u>Product Labelling</u></b> .....	17
6.0	<b><u>Technical Specifications</u></b> .....	17
7.0	<b><u>Instruction Manual</u></b> .....	17
8.0	<b><u>Miscellaneous Information</u></b> .....	18
8.1	Radiated Emission on the Bandedge .....	18
8.2	Discussion of Pulse Desensitization .....	23
8.3	Calculation of Average Factor .....	23
8.4	Emissions Test Procedures .....	24
8.5	Occupied Bandwidth.....	28
9.0	<b><u>Equipment List</u></b> .....	30

---

## INTERTEK TESTING SERVICES

---

### 1.0 General Description

#### 1.1 Product Description

The Equipment Under Test (EUT) is a Tablet, equipped with keyboard, headphone, WiFi, Bluetooth, SD, HDMI and USB Interface. The EUT is powered by an external AC/DC adaptor (5VDC output) or/and internal 3.7VDC rechargeable battery. The adaptor accepts 100-240VAC.

The Model: W1013, W101 V2 are the same as the Model: WT19503W in hardware aspect. The difference in model number and brand name serves as marketing strategy.

##### For the WLAN (WiFi) module:

For 802.11b mode, it operates at frequency range of 2412.000MHz to 2462.000MHz with 11 channels. It transmits via direct-sequence spread spectrum (DSSS) modulation. Maximum bit rate can be up to 11Mbps. For 802.11g mode, it operates at frequency range of 2412.000MHz to 2462.000MHz with 11 channels. It transmits via Orthogonal Frequency Division Multiplexing (OFDM) modulation. Maximum bit rate can be up to 54Mbps. For 802.11n (HT20 with 20MHz bandwidth) mode, it operates at frequency range of 2412.000MHz to 2462.000MHz with 11 channels. It transmits via Orthogonal Frequency Division Multiplexing (OFDM) modulation (mcs0 to mcs7). Maximum bit rate can support up to 65Mbps. For 802.11n (HT40 with 40MHz bandwidth) mode, it operates at frequency range of 2422.000MHz to 2452.000MHz with 9 channels. It transmits via Orthogonal Frequency Division Multiplexing (OFDM) modulation (mcs0 to mcs7). Maximum bit rate can support up to 130Mbps.

##### For Bluetooth module:

For Bluetooth 4.0 BLE mode, it occupies a frequency range from 2402MHz to 2480MHz (40 channels with channel spacing of 2MHz). It transmits via GFSK modulation.

For Bluetooth 3.0 mode, it occupies a frequency range from 2402MHz to 2480MHz (79 channels with channel spacing of 1MHz). It transmits via GFSK modulation.

Antenna Type: Internal, Integral

For electronic filing, the brief circuit description is saved with filename: descri.pdf.

## INTERTEK TESTING SERVICES

---

### 1.2 Related Submittal(s) Grants

This is a single application for certification of a transceiver.

The Declaration of the Conformity procedure of PC Connectivity for this transceiver (with FCC ID: A2HW1013 and IC: 9903A-W1013) is being processed as the same time of this application.

### 1.3 Test Methodology

Both AC mains line-conducted and radiated emission measurements were performed according to the procedures in ANSI C63.10 (2013). All radiated measurements were performed in an 3m Chamber. Preliminary scans were performed in the 3m Chamber only to determine worst case modes. All radiated tests were performed at an antenna to EUT distance of 3 meters, unless stated otherwise in the “**Justification Section**” of this Application.

### 1.4 Test Facility

The 3m Chamber and conducted measurement facility used to collect the radiated data is located at Workshop No. 3, G/F., World-Wide Industrial Centre, 43-47 Shan Mei Street, Fo Tan, Sha Tin, N.T., Hong Kong. This test facility and site measurement data have been placed on file with the FCC and IC.

---

## INTERTEK TESTING SERVICES

---

### 2.0 System Test Configuration

#### 2.1 Justification

The system was configured for testing in a typical fashion (as a customer would normally use it), and in the confines as outlined in ANSI C63.10 (2013).

The device was powered by 120VAC.

Two types of AC/DC adaptors were supplied by the applicant.

Model: APS-L012050200W-G, Brand: ACT (worse case)

(Input: 100V-240VAC 50/60Hz, Output: 5VDC 2A)

Model: STC-U100502000-Z, Brand: DOKOCOM

(Input: 100V-240VAC 50-60Hz, Output: 5VDC 2A)

All adaptors were tested and only worse case data is shown in this report.

For the measurements, the EUT was attached to a plastic stand if necessary and placed on the wooden turntable which is four feet in diameter and approximately 0.8m in height above the ground plane for emission measurement at or below 1GHz and 1.5m in height above the ground plane for emission measurement above 1GHz. If the base unit attached to peripherals, they were connected and operational (as typical as possible).

The signal was maximized through rotation and placement in the three orthogonal axes. The antenna height and polarization were varied during the search for maximum signal level. The antenna height was varied from 1 to 4 meters. Radiated emissions were taken at three meters unless the signal level was too low for measurement at that distance. If necessary, a pre-amplifier was used and/or the test was conducted at a closer distance.

For any intentional radiator powered by AC power line, measurements of the radiated signal level of the fundamental frequency component of the emission was performed with the supply voltage varied between 85% and 115% of the nominal rated supply voltage.

Radiated emission measurement for transmitter were performed from the lowest radio frequency signal generated in the device which is greater than 9 kHz to the tenth harmonic of the highest fundamental frequency or to 40 GHz, whichever is lower.

## INTERTEK TESTING SERVICES

---

### Justification – Cont'd

Emission that are directly caused by digital circuits in the transmit path and transmitter portion were measured, and the limit are according to FCC Part 15 Section 15.209/ RSS-247 2.5. Digital circuitries used to control additional functions other than the operation of the transmitter are subject to FCC Part 15 Section 15.109/ RSS-247 Section 5.5 Limits.

Detector function for radiated emissions was in peak mode. Average readings, when required, were taken by measuring the duty cycle of the equipment under test and subtracting the corresponding amount in dB from the measured peak readings. A detailed description for the calculation of the average factor can be found in section 4.2.3.

Determination of pulse desensitization was made according to *Hewlett Packard Application Note 150-2, Spectrum Analysis... Pulsed RF*. The effective period (Teff) was referred to Exhibit 4.6.3. With the resolution bandwidth 1MHz and spectrum analyzer IF bandwidth 3dB, the pulse desensitization factor was 0dB.

The EUT along with its peripherals were placed on a 1.0m(W)x1.5m(L) and 0.8m in height wooden table and the EUT was adjusted to maintain a 0.4 meter space from a vertical reference plane. The EUT power cord connected to one LISN (Line impedance stabilization network), which provided 50ohm coupling impedance for measuring instrument. Meanwhile, the peripheral or support equipment power cords connected to a separate LISN. The ac powers for all LISNs were obtained from the same power source. The LISN housing, measuring instrument case, reference ground plane, and vertical ground plane were bounded together. The excess power cable between the EUT and the LISN was bundled. Power cords of non-EUT equipment (peripherals) were not bundled. AC power cords of peripheral equipments draped over the rear edge of the table, and routed them down onto the floor of the ac power line conducted emission test site to the second LISN.

All connecting cables of EUT and peripherals were manipulated to find the maximum emission.

All configuration mode (with and without PC connectivity during transceiver test) and setting of data rate for 802.11b/g/n(HT20)/n(HT40) of WiFi mode had been considered, and worst case test data are shown on this test report.

For simultaneous transmission, both WiFi and Bluetooth portions are also switched on when taking radiated emission for determining worst-case spurious emission.



---

## INTERTEK TESTING SERVICES

---

### 2.2 EUT Exercising Software

There was no special software to exercise the device. Once the unit is powered up, it transmits the RF signal continuously.

### 2.3 Special Accessories

There are no special accessories necessary for compliance of this product.

### 2.4 Measurement Uncertainty

When determining of the test conclusion, the Measurement Uncertainty of test has been considered.

Uncertainty and Compliance - Unless the standard specifically states that measured values are to be extended by the measurement uncertainty in determining compliance, all compliance determinations are based on the actual measured value.

### 2.5 Support Equipment List and Description

1. Headphone of 1.2m long cable
2. 4GB USB Flash
3. 4GB Micro SD Card
4. HDMI Monitor
5. HDMI cable of 2m long
6. LAN cable of 2m long
7. Notebook Computer
8. USB cable of 1m long  
(Provided by Intertek)
9. AC/DC Adaptor  
Model: APS-L012050200W-G, Brand: ACT (worse case)  
(Input: 100-240VAC 50/60Hz, Output: 5VDC 2A)  
(Provided by Applicant)

---

## INTERTEK TESTING SERVICES

---

### 3.0 Emission Results

Data is included of the worst case configuration (the configuration which resulted in the highest emission levels). A sample calculation, configuration photographs and data tables of the emissions are included.

#### 3.1 Field Strength Calculation

The field strength is calculated by adding the Antenna Factor and Cable Factor, and subtracting the Amplifier Gain (if any), Average Factor (optional) from the measured reading. The basic equation with a sample calculation is as follows:

$$FS = RA + AF + CF - AG - AV$$

where

- FS = Field Strength in dB $\mu$ V/m
- RA = Receiver Amplitude (including preamplifier) in dB $\mu$ V
- CF = Cable Attenuation Factor in dB
- AF = Antenna Factor in dB
- AG = Amplifier Gain in dB
- AV = Average Factor in dB

In the following table(s), the reading shown on the data table reflects the preamplifier gain. An example for the calculations in the following table is as follows:

$$FS = RR + LF$$

where

- FS = Field Strength in dB $\mu$ V/m
- RR = RA - AG - AV in dB $\mu$ V
- LF = CF + AF in dB

Assume a receiver reading of 52.0 dB $\mu$ V is obtained. The antenna factor of 7.4 dB and cable factor of 1.6 dB are added. The amplifier gain of 29 dB and average factor of 5 dB are subtracted, giving a field strength of 32 dB $\mu$ V/m. This value in dB $\mu$ V/m was converted to its corresponding level in  $\mu$ V/m.

RA = 52.0 dB $\mu$ V/m	
AF = 7.4 dB	RR = 18.0 dB $\mu$ V
CF = 1.6 dB	LF = 9.0 dB
AG = 29.0 dB	
AV = 5.0 dB	
FS = RR + LF	
FS = 18 + 9 = 27 dB $\mu$ V/m	

Level in  $\mu$ V/m = Common Antilogarithm [(27 dB $\mu$ V/m)/20] = 22.4  $\mu$ V/m

## INTERTEK TESTING SERVICES

---

### 3.2 Radiated Emission Configuration Photograph

The worst case in radiated emission was found at 199.992 MHz

For electronic filing, the worst case radiated emission configuration photographs are saved with filename: radiated photos.pdf.

### 3.3 Radiated Emission Data

The data on the following page lists the significant emission frequencies, the limit and the margin of compliance. Numbers with a minus sign are below the limit.

Judgment: Passed by 0.2 dB

### 3.4 Conducted Emission Configuration Photograph

The worst case in line-conducted emission was found at 0.186 MHz

For electronic filing, the worst case line-conducted configuration photographs are saved with filename: conducted photo.pdf.

### 3.5 Conducted Emission Data

For electronic filing, the graph and data table of conducted emission is saved with filename: conducted.pdf.

Judgment: Pass by 4.3 dB

## INTERTEK TESTING SERVICES

Applicant: Alco Electronics Ltd

Date of Test: May 24, 2016

Model: WT19503W

Worst-Case Operating Mode: EUT Simultaneous Transmitting (WiFi and Bluetooth)

EDIT PEAK LIST (Final Measurement Results)				
Trace1:	CF15MQP			
Trace2:	CF15MAV			
Trace3:	---			
TRACE	FREQUENCY	LEVEL dBμV		DELTA LIMIT dB
1 Quasi Peak	186 kHz	59.95	N	-4.26
2 CISPR Average	186 kHz	47.80	N	-6.41
1 Quasi Peak	244.5 kHz	51.45	N	-10.48
2 CISPR Average	253.5 kHz	35.85	L1	-15.79
2 CISPR Average	312 kHz	35.81	N	-14.10
1 Quasi Peak	321 kHz	42.88	L1	-16.79
2 CISPR Average	442.5 kHz	31.72	N	-15.29
1 Quasi Peak	505.5 kHz	39.91	N	-16.08
2 CISPR Average	568.5 kHz	24.74	N	-21.25
1 Quasi Peak	613.5 kHz	41.72	N	-14.27
1 Quasi Peak	897 kHz	39.27	L1	-16.72
2 CISPR Average	951 kHz	31.39	N	-14.60
1 Quasi Peak	1.095 MHz	39.31	N	-16.68
2 CISPR Average	1.2345 MHz	30.73	L1	-15.26
2 CISPR Average	1.545 MHz	31.75	L1	-14.24
1 Quasi Peak	1.599 MHz	31.71	N	-24.28
1 Quasi Peak	2.9085 MHz	36.49	L1	-19.50
2 CISPR Average	2.922 MHz	31.07	L1	-14.93
2 CISPR Average	3.4485 MHz	32.23	N	-13.77
1 Quasi Peak	3.489 MHz	37.41	N	-18.58

EDIT PEAK LIST (Final Measurement Results)				
Trace1:	CF15MQP			
Trace2:	CF15MAV			
Trace3:	---			
TRACE	FREQUENCY	LEVEL dBμV		DELTA LIMIT dB
2 CISPR Average	11.085 MHz	32.36	N	-17.63
1 Quasi Peak	11.0985 MHz	37.43	N	-22.56
1 Quasi Peak	11.9445 MHz	39.43	L1	-20.56
2 CISPR Average	12.012 MHz	33.34	N	-16.66

Note: Measurement Uncertainty is  $\pm 4.2$ dB at a level of confidence of 95%.

# INTERTEK TESTING SERVICES

Applicant: Alco Electronics Ltd

Date of Test: May 24, 2016

Model: WT19503W

Worst-Case Operating Mode: EUT Simultaneous Transmitting (WiFi and Bluetooth)

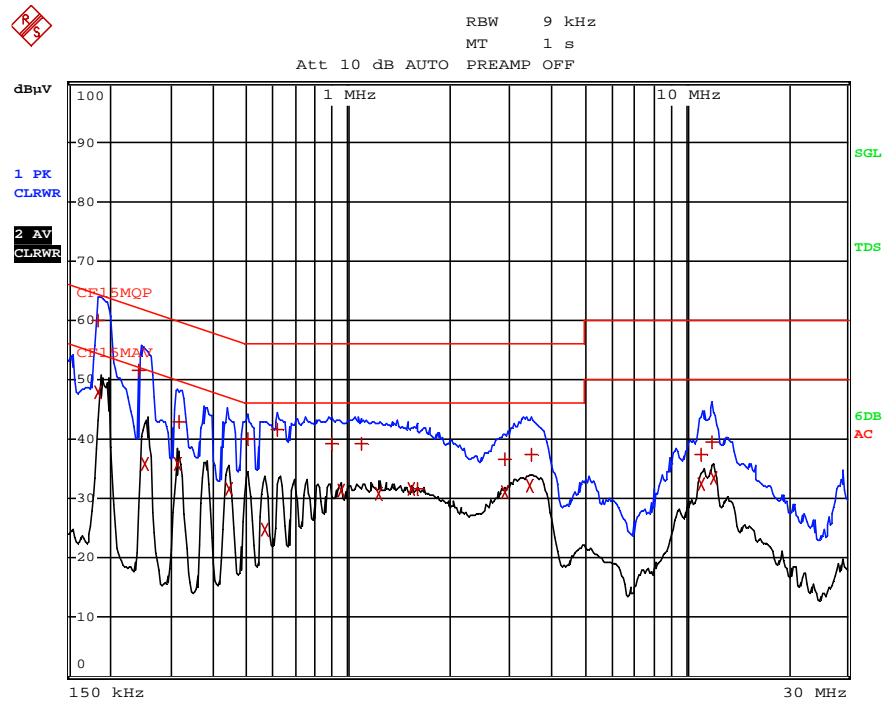

Note: Measurement Uncertainty is  $\pm 4.2$ dB at a level of confidence of 95%.

## INTERTEK TESTING SERVICES

Applicant: Alco Electronics Ltd  
 Model: WT19503W

Date of Test: June 11, 2016

Worst-Case Operating Mode: Transmitting (Bluetooth 3.0)

Table 1  
**Radiated Emissions**  
 Pursuant to FCC Part 15 Section 15.249 / RSS-210 A2.9 Requirement

**Lowest Channel**

Polarization	Frequency (MHz)	Reading (dB $\mu$ V)	Pre-Amp Gain (dB)	Antenna Factor (dB)	Net at 3m - Peak (dB $\mu$ V/m)	Average Factor (dB)	Calculated at 3m (dB $\mu$ V/m)	Average Limit at 3m (dB $\mu$ V/m)	Margin (dB)
H	2402.000	96.8	33	29.4	93.2	24	69.2	94.0	-24.8
<b>H</b>	<b>4804.000</b>	<b>40.7</b>	<b>33</b>	<b>34.9</b>	<b>42.6</b>	<b>24</b>	<b>18.6</b>	<b>54.0</b>	<b>-35.4</b>
H	7206.000	40.3	33	37.9	45.2	24	21.2	54.0	-32.8
H	9608.000	40.8	33	40.4	48.2	24	24.2	54.0	-29.8
<b>H</b>	<b>12010.000</b>	<b>43.9</b>	<b>33</b>	<b>40.5</b>	<b>51.4</b>	<b>24</b>	<b>27.4</b>	<b>54.0</b>	<b>-26.6</b>
H	14412.000	44.6	33	40.0	52.4	24	28.4	54.0	-25.6

Polarization	Frequency (MHz)	Reading (dB $\mu$ V)	Pre-Amp Gain (dB)	Antenna Factor (dB)	Net at 3m - Peak (dB $\mu$ V/m)	Peak Limit at 3m (dB $\mu$ V/m)	Margin (dB)
H	2402.000	96.8	33	29.4	93.2	114.0	-20.8
<b>H</b>	<b>4804.000</b>	<b>40.7</b>	<b>33</b>	<b>34.9</b>	<b>42.6</b>	<b>74.0</b>	<b>-31.4</b>
H	7206.000	40.3	33	37.9	45.2	74.0	-28.8
H	9608.000	40.8	33	40.4	48.2	74.0	-25.8
<b>H</b>	<b>12010.000</b>	<b>43.9</b>	<b>33</b>	<b>40.5</b>	<b>51.4</b>	<b>74.0</b>	<b>-22.6</b>
H	14412.000	44.6	33	40.0	52.4	74.0	-21.6

NOTES: 1. Peak Detector Data unless otherwise stated.

2. All measurements were made at 3 meters. Harmonic emissions not detected at the 3-meter distances were measured at 0.3-meter and an inverse proportional extrapolation was performed to compare the signal level to the 3-meter limit. No other harmonic emissions than those reported were detected at a test distance of 0.3-meter.
3. Negative sign in the column shows value below limit.
4. Horn antenna is used for the emission over 1000MHz.
5. Emission (the row indicated by **bold italic**) within the restricted band meets the requirement of FCC Part 15 Section 15.205 / RSS-210 Section 2.2.
6. Measurement Uncertainty is  $\pm 5.3$ dB at a level of confidence of 95%.

## INTERTEK TESTING SERVICES

Applicant: Alco Electronics Ltd  
 Model: WT19503W

Date of Test: June 11, 2016

Worst-Case Operating Mode: Transmitting (Bluetooth 3.0)

Table 2  
**Radiated Emissions**  
 Pursuant to FCC Part 15 Section 15.249 / RSS-210 A2.9 Requirement

Middle Channel

Polarization	Frequency (MHz)	Reading (dB $\mu$ V)	Pre-Amp Gain (dB)	Antenna Factor (dB)	Net at 3m - Peak (dB $\mu$ V/m)	Average Factor (dB)	Calculated at 3m (dB $\mu$ V/m)	Average Limit at 3m (dB $\mu$ V/m)	Margin (dB)
H	2442.000	96.0	33	29.4	92.4	24	68.4	94.0	-25.6
<b>H</b>	<b>4884.000</b>	<b>40.9</b>	<b>33</b>	<b>34.9</b>	<b>42.8</b>	<b>24</b>	<b>18.8</b>	<b>54.0</b>	<b>-35.2</b>
<b>H</b>	<b>7326.000</b>	<b>40.5</b>	<b>33</b>	<b>37.9</b>	<b>45.4</b>	<b>24</b>	<b>21.4</b>	<b>54.0</b>	<b>-32.6</b>
H	9768.000	40.8	33	40.4	48.2	24	24.2	54.0	-29.8
<b>H</b>	<b>12210.000</b>	<b>43.9</b>	<b>33</b>	<b>40.5</b>	<b>51.4</b>	<b>24</b>	<b>27.4</b>	<b>54.0</b>	<b>-26.6</b>
H	14652.000	47.0	33	38.4	52.4	24	28.4	54.0	-25.6

Polarization	Frequency (MHz)	Reading (dB $\mu$ V)	Pre-Amp Gain (dB)	Antenna Factor (dB)	Net at 3m - Peak (dB $\mu$ V/m)	Peak Limit at 3m (dB $\mu$ V/m)	Margin (dB)
H	2442.000	96.0	33	29.4	92.4	114.0	-21.6
<b>H</b>	<b>4884.000</b>	<b>40.9</b>	<b>33</b>	<b>34.9</b>	<b>42.8</b>	<b>74.0</b>	<b>-31.2</b>
<b>H</b>	<b>7326.000</b>	<b>40.5</b>	<b>33</b>	<b>37.9</b>	<b>45.4</b>	<b>74.0</b>	<b>-28.6</b>
H	9768.000	40.8	33	40.4	48.2	74.0	-25.8
<b>H</b>	<b>12210.000</b>	<b>43.9</b>	<b>33</b>	<b>40.5</b>	<b>51.4</b>	<b>74.0</b>	<b>-22.6</b>
H	14652.000	47.0	33	38.4	52.4	74.0	-21.6

NOTES: 1. Peak Detector Data unless otherwise stated.

2. All measurements were made at 3 meters. Harmonic emissions not detected at the 3-meter distances were measured at 0.3-meter and an inverse proportional extrapolation was performed to compare the signal level to the 3-meter limit. No other harmonic emissions than those reported were detected at a test distance of 0.3-meter.
3. Negative sign in the column shows value below limit.
4. Horn antenna is used for the emission over 1000MHz.
5. Emission (the row indicated by **bold italic**) within the restricted band meets the requirement of FCC Part 15 Section 15.205 / RSS-210 Section 2.2.
6. Measurement Uncertainty is  $\pm 5.3$ dB at a level of confidence of 95%.

## INTERTEK TESTING SERVICES

Applicant: Alco Electronics Ltd  
 Model: WT19503W

Date of Test: June 11, 2016

Worst-Case Operating Mode: Transmitting (Bluetooth 3.0)

Table 3  
**Radiated Emissions**  
 Pursuant to FCC Part 15 Section 15.249 / RSS-210 A2.9 Requirement

Highest Channel

Polarization	Frequency (MHz)	Reading (dB $\mu$ V)	Pre-Amp Gain (dB)	Antenna Factor (dB)	Net at 3m - Peak (dB $\mu$ V/m)	Average Factor (dB)	Calculated at 3m (dB $\mu$ V/m)	Average Limit at 3m (dB $\mu$ V/m)	Margin (dB)
H	2480.000	95.2	33	29.4	91.6	24	67.6	94.0	-26.4
<b>H</b>	<b>4960.000</b>	<b>41.3</b>	<b>33</b>	<b>34.9</b>	<b>43.2</b>	<b>24</b>	<b>19.2</b>	<b>54.0</b>	<b>-34.8</b>
<b>H</b>	<b>7440.000</b>	<b>40.7</b>	<b>33</b>	<b>37.9</b>	<b>45.6</b>	<b>24</b>	<b>21.6</b>	<b>54.0</b>	<b>-32.4</b>
H	9920.000	40.4	33	40.4	47.8	24	23.8	54.0	-30.2
<b>H</b>	<b>12400.000</b>	<b>44.1</b>	<b>33</b>	<b>40.5</b>	<b>51.6</b>	<b>24</b>	<b>27.6</b>	<b>54.0</b>	<b>-26.4</b>
H	14880.000	45.8	33	38.4	52.4	24	28.4	54.0	-25.6

Polarization	Frequency (MHz)	Reading (dB $\mu$ V)	Pre-Amp Gain (dB)	Antenna Factor (dB)	Net at 3m - Peak (dB $\mu$ V/m)	Peak Limit at 3m (dB $\mu$ V/m)	Margin (dB)
H	2480.000	95.2	33	29.4	91.6	114.0	-22.4
<b>H</b>	<b>4960.000</b>	<b>41.3</b>	<b>33</b>	<b>34.9</b>	<b>43.2</b>	<b>74.0</b>	<b>-30.8</b>
<b>H</b>	<b>7440.000</b>	<b>40.7</b>	<b>33</b>	<b>37.9</b>	<b>45.6</b>	<b>74.0</b>	<b>-28.4</b>
H	9920.000	40.4	33	40.4	47.8	74.0	-26.2
<b>H</b>	<b>12400.000</b>	<b>44.1</b>	<b>33</b>	<b>40.5</b>	<b>51.6</b>	<b>74.0</b>	<b>-22.4</b>
H	14880.000	45.8	33	38.4	52.4	74.0	-21.6

NOTES: 1. Peak Detector Data unless otherwise stated.

2. All measurements were made at 3 meters. Harmonic emissions not detected at the 3-meter distances were measured at 0.3-meter and an inverse proportional extrapolation was performed to compare the signal level to the 3-meter limit. No other harmonic emissions than those reported were detected at a test distance of 0.3-meter.
3. Negative sign in the column shows value below limit.
4. Horn antenna is used for the emission over 1000MHz.
5. Emission (the row indicated by **bold italic**) within the restricted band meets the requirement of FCC Part 15 Section 15.205 / RSS-210 Section 2.2.
6. Measurement Uncertainty is  $\pm 5.3$ dB at a level of confidence of 95%.



## INTERTEK TESTING SERVICES

Applicant: Alco Electronics Ltd

Date of Test: June 11, 2016

Model: WT19503W

Worst-Case Operating Mode: Transmitting (Bluetooth 4.0 BLE)

Table 4  
**Radiated Emissions**  
**Pursuant to FCC Part 15 Section 15.249 / RSS-210 A2.9 Requirement**

**Lowest Channel**

Polarization	Frequency (MHz)	Reading (dB $\mu$ V)	Pre-Amp Gain (dB)	Antenna Factor (dB)	Net at 3m - Average (dB $\mu$ V/m)	Average Limit at 3m (dB $\mu$ V/m)	Margin (dB)
H	2402.000	95.8	33	29.4	92.2	94.0	-1.8
<b>H</b>	<b>4804.000</b>	<b>39.5</b>	<b>33</b>	<b>34.9</b>	<b>41.4</b>	<b>54.0</b>	<b>-12.6</b>
H	7206.000	40.3	33	37.9	45.2	54.0	-8.8
H	9608.000	40.6	33	40.4	48.0	54.0	-6.0
<b>H</b>	<b>12010.000</b>	<b>43.9</b>	<b>33</b>	<b>40.5</b>	<b>51.4</b>	<b>54.0</b>	<b>-2.6</b>
H	14412.000	45.8	33	40.0	52.8	54.0	-1.2

Polarization	Frequency (MHz)	Reading (dB $\mu$ V)	Pre-Amp Gain (dB)	Antenna Factor (dB)	Net at 3m - Peak (dB $\mu$ V/m)	Peak Limit at 3m (dB $\mu$ V/m)	Margin (dB)
H	2402.000	95.8	33	29.4	92.2	114.0	-21.8
<b>H</b>	<b>4804.000</b>	<b>39.5</b>	<b>33</b>	<b>34.9</b>	<b>41.4</b>	<b>74.0</b>	<b>-32.6</b>
H	7206.000	40.3	33	37.9	45.2	74.0	-28.8
H	9608.000	40.6	33	40.4	48.0	74.0	-26.0
<b>H</b>	<b>12010.000</b>	<b>43.9</b>	<b>33</b>	<b>40.5</b>	<b>51.4</b>	<b>74.0</b>	<b>-22.6</b>
H	14412.000	45.8	33	40.0	52.8	74.0	-21.2

- NOTES: 1. Peak Detector Data unless otherwise stated.
2. All measurements were made at 3 meters. Harmonic emissions not detected at the 3-meter distances were measured at 0.3-meter and an inverse proportional extrapolation was performed to compare the signal level to the 3-meter limit. No other harmonic emissions than those reported were detected at a test distance of 0.3-meter.
3. Negative sign in the column shows value below limit.
4. Horn antenna is used for the emission over 1000MHz.
5. Emission (the row indicated by **bold italic**) within the restricted band meets the requirement of FCC Part 15 Section 15.205 / RSS-210 Section 2.2.
6. Measurement Uncertainty is  $\pm 5.3$ dB at a level of confidence of 95%.

## INTERTEK TESTING SERVICES

Applicant: Alco Electronics Ltd

Date of Test: June 11, 2016

Model: WT19503W

Worst-Case Operating Mode: Transmitting (Bluetooth 4.0 BLE)

Table 5  
**Radiated Emissions**  
**Pursuant to FCC Part 15 Section 15.249 / RSS-210 A2.9 Requirement**

Middle Channel

Polarization	Frequency (MHz)	Reading (dB $\mu$ V)	Pre-Amp Gain (dB)	Antenna Factor (dB)	Net at 3m - Average (dB $\mu$ V/m)	Average Limit at 3m (dB $\mu$ V/m)	Margin (dB)
H	2442.000	95.6	33	29.4	92.0	94.0	-2.0
<b>H</b>	<b>4884.000</b>	<b>39.6</b>	<b>33</b>	<b>34.9</b>	<b>41.5</b>	<b>54.0</b>	<b>-12.5</b>
<b>H</b>	<b>7326.000</b>	<b>39.5</b>	<b>33</b>	<b>37.9</b>	<b>44.4</b>	<b>54.0</b>	<b>-9.6</b>
H	9768.000	40.8	33	40.4	48.2	54.0	-5.8
<b>H</b>	<b>12210.000</b>	<b>43.9</b>	<b>33</b>	<b>40.5</b>	<b>51.4</b>	<b>54.0</b>	<b>-2.6</b>
H	14652.000	46.8	33	38.4	52.2	54.0	-1.8

Polarization	Frequency (MHz)	Reading (dB $\mu$ V)	Pre-Amp Gain (dB)	Antenna Factor (dB)	Net at 3m - Peak (dB $\mu$ V/m)	Peak Limit at 3m (dB $\mu$ V/m)	Margin (dB)
H	2442.000	95.6	33	29.4	92.0	114.0	-22.0
<b>H</b>	<b>4884.000</b>	<b>39.6</b>	<b>33</b>	<b>34.9</b>	<b>41.5</b>	<b>74.0</b>	<b>-32.5</b>
<b>H</b>	<b>7326.000</b>	<b>39.5</b>	<b>33</b>	<b>37.9</b>	<b>44.4</b>	<b>74.0</b>	<b>-29.6</b>
H	9768.000	40.8	33	40.4	48.2	74.0	-25.8
<b>H</b>	<b>12210.000</b>	<b>43.9</b>	<b>33</b>	<b>40.5</b>	<b>51.4</b>	<b>74.0</b>	<b>-22.6</b>
H	14652.000	46.8	33	38.4	52.2	74.0	-21.8

NOTES: 1. Peak Detector Data unless otherwise stated.

2. All measurements were made at 3 meters. Harmonic emissions not detected at the 3-meter distances were measured at 0.3-meter and an inverse proportional extrapolation was performed to compare the signal level to the 3-meter limit. No other harmonic emissions than those reported were detected at a test distance of 0.3-meter.
3. Negative sign in the column shows value below limit.
4. Horn antenna is used for the emission over 1000MHz.
5. Emission (the row indicated by **bold italic**) within the restricted band meets the requirement of FCC Part 15 Section 15.205 / RSS-210 Section 2.2.
6. Measurement Uncertainty is  $\pm 5.3$ dB at a level of confidence of 95%.

## INTERTEK TESTING SERVICES

Applicant: Alco Electronics Ltd

Date of Test: June 11, 2016

Model: WT19503W

Worst-Case Operating Mode: Transmitting (Bluetooth 4.0 BLE)

Table 6  
**Radiated Emissions**  
**Pursuant to FCC Part 15 Section 15.249 / RSS-210 A2.9 Requirement**

Highest Channel

Polarization	Frequency (MHz)	Reading (dB $\mu$ V)	Pre-Amp Gain (dB)	Antenna Factor (dB)	Net at 3m -Average (dB $\mu$ V/m)	Average Limit at 3m (dB $\mu$ V/m)	Margin (dB)
H	2480.000	94.8	33	29.4	91.2	94.0	-2.8
<b>H</b>	<b>4960.000</b>	<b>39.7</b>	<b>33</b>	<b>34.9</b>	<b>41.6</b>	<b>54.0</b>	<b>-12.4</b>
<b>H</b>	<b>7440.000</b>	<b>40.5</b>	<b>33</b>	<b>37.9</b>	<b>45.4</b>	<b>54.0</b>	<b>-8.6</b>
H	9920.000	40.8	33	40.4	48.2	54.0	-5.8
<b>H</b>	<b>12400.000</b>	<b>44.0</b>	<b>33</b>	<b>40.5</b>	<b>51.5</b>	<b>54.0</b>	<b>-2.5</b>
H	14880.000	47.3	33	38.4	52.7	54.0	-1.3

Polarization	Frequency (MHz)	Reading (dB $\mu$ V)	Pre-Amp Gain (dB)	Antenna Factor (dB)	Net at 3m - Peak (dB $\mu$ V/m)	Peak Limit at 3m (dB $\mu$ V/m)	Margin (dB)
H	2480.000	94.8	33	29.4	91.2	114.0	-22.8
<b>H</b>	<b>4960.000</b>	<b>39.7</b>	<b>33</b>	<b>34.9</b>	<b>41.6</b>	<b>74.0</b>	<b>-32.4</b>
<b>H</b>	<b>7440.000</b>	<b>40.5</b>	<b>33</b>	<b>37.9</b>	<b>45.4</b>	<b>74.0</b>	<b>-28.6</b>
H	9920.000	40.8	33	40.4	48.2	74.0	-25.8
<b>H</b>	<b>12400.000</b>	<b>44.0</b>	<b>33</b>	<b>40.5</b>	<b>51.5</b>	<b>74.0</b>	<b>-22.5</b>
H	14880.000	47.3	33	38.4	52.7	74.0	-21.3

- NOTES: 1. Peak Detector Data unless otherwise stated.
2. All measurements were made at 3 meters. Harmonic emissions not detected at the 3-meter distances were measured at 0.3-meter and an inverse proportional extrapolation was performed to compare the signal level to the 3-meter limit. No other harmonic emissions than those reported were detected at a test distance of 0.3-meter.
3. Negative sign in the column shows value below limit.
4. Horn antenna is used for the emission over 1000MHz.
5. Emission (the row indicated by **bold italic**) within the restricted band meets the requirement of FCC Part 15 Section 15.205 / RSS-210 Section 2.2.
6. Measurement Uncertainty is  $\pm 5.3$ dB at a level of confidence of 95%.

## INTERTEK TESTING SERVICES

Applicant: Alco Electronics Ltd  
 Model: WT19503W

Date of Test: June 11, 2016

Worst-Case Operating Mode: EUT Simultaneous Transmitting (WiFi and Bluetooth)

Table 7  
**Radiated Emissions**  
 Pursuant to FCC Part 15 Section 15.209 / RSS-210 2.5 Requirement

Polarization	Frequency (MHz)	Reading (dB $\mu$ V)	Pre-amp (dB)	Antenna Factor (dB)	Net at 3m (dB $\mu$ V/m)	Limit at 3m (dB $\mu$ V/m)	Margin (dB)
V	31.212	28.6	16	10.0	22.6	40.0	-17.4
V	42.610	19.5	16	10.0	13.5	40.0	-26.5
H	85.410	28.6	16	8.0	20.6	40.0	-19.4
<b>H</b>	<b>110.752</b>	<b>28.2</b>	<b>16</b>	<b>14.0</b>	<b>26.2</b>	<b>43.5</b>	<b>-17.3</b>
<b>H</b>	<b>149.916</b>	<b>32.2</b>	<b>16</b>	<b>14.0</b>	<b>30.2</b>	<b>43.5</b>	<b>-13.3</b>
H	199.992	43.3	16	16.0	43.3	43.5	-0.2
H	229.578	33.5	16	18.0	35.5	46.0	-10.5
H	238.186	32.4	16	19.0	35.4	46.0	-10.6
<b>H</b>	<b>274.440</b>	<b>25.5</b>	<b>16</b>	<b>22.0</b>	<b>31.5</b>	<b>46.0</b>	<b>-14.5</b>
H	349.978	19.8	16	24.0	27.8	46.0	-18.2
H	506.270	21.5	16	27.0	32.5	46.0	-13.5
H	731.310	19.6	16	30.0	33.6	46.0	-12.4
H	800.058	23.2	16	31.0	38.2	46.0	-7.8
H	959.988	16.8	16	33.0	33.8	46.0	-12.2

- NOTES: 1. Peak Detector Data unless otherwise stated.
2. All measurements were made at 3 meters. Harmonic emissions not detected at the 3-meter distances were measured at 0.3-meter and an inverse proportional extrapolation was performed to compare the signal level to the 3-meter limit. No other harmonic emissions than those reported were detected at a test distance of 0.3-meter.
3. Negative sign in the column shows value below limit.
4. Horn antenna is used for the emission over 1000MHz.
5. Emission (the row indicated by **bold italic**) within the restricted band meets the requirement of FCC Part 15 Section 15.205 / RSS-210 Section 2.2.
6. Measurement Uncertainty is  $\pm 5.3$ dB at a level of confidence of 95%.

## INTERTEK TESTING SERVICES

---

### 4.0 **Equipment Photographs**

For electronic filing, the photographs are saved with filename: external photos.pdf and internal photos.pdf.

### 5.0 **Product Labelling**

For electronics filing, the FCC ID label artwork and the label location are saved with filename: label.pdf.

### 6.0 **Technical Specifications**

For electronic filing, the block diagram and schematic of the tested EUT are saved with filename: block.pdf and circuit.pdf respectively.

### 7.0 **Instruction Manual**

For electronic filing, a preliminary copy of the Instruction Manual is saved with filename: manual.pdf.

This manual will be provided to the end-user with each unit sold/leased in the United States and Canada.

## INTERTEK TESTING SERVICES

---

### 8.0 Miscellaneous Information

The miscellaneous information includes details of the test procedure and measured bandwidth / calculation of factor such as pulse desensitization and averaging factor (calculation and timing diagram).

### 8.1 Radiated Emission on the Bandedge

From the following plots, they show that the fundamental emissions are confined in the specified band (2400MHz to 2483.5MHz). In case of the fundamental emissions are within two standard bandwidths from the bandedge, the delta measurement technique is used for determining bandedge compliance. Standard bandwidth is the bandwidth specified by ANSI C63.10 (2013) for frequency being measured.

Emissions radiated outside of the specified frequency bands, except harmonics, are attenuated by 50dB below the level of the fundamental or to the general radiated emissions limits in Section 15.209 / RSS-210 2.5, whichever is the lesser attenuation, which meet the requirement of part 15.249(d) / RSS-210 A2.9.

# INTERTEK TESTING SERVICES

## Peak Measurement (Bluetooth 3.0)

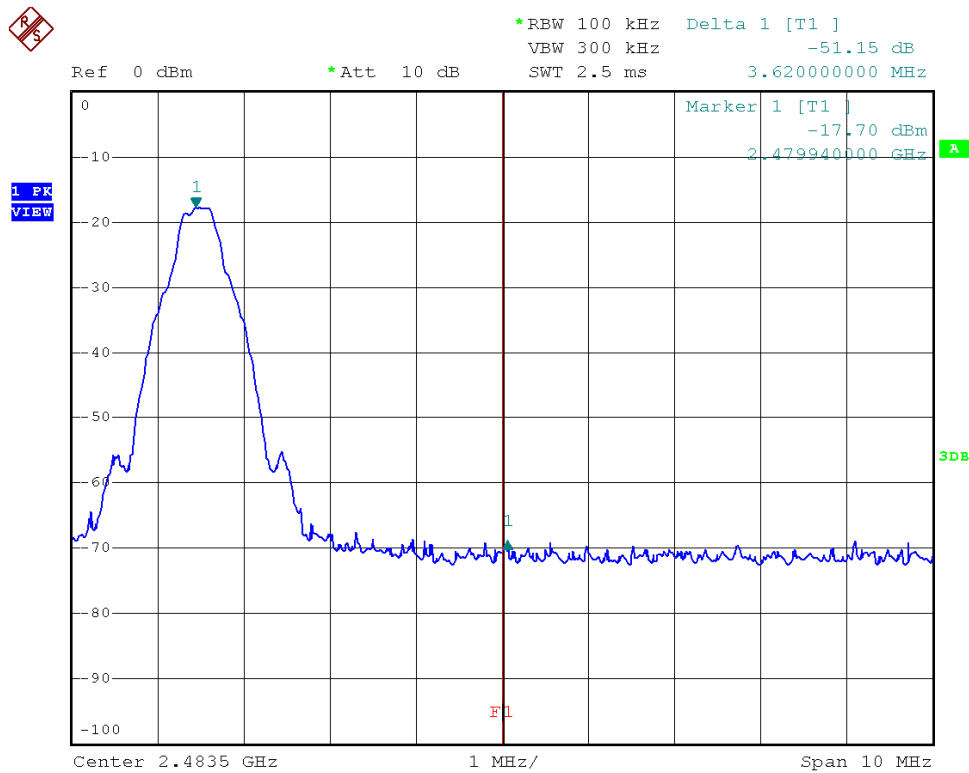
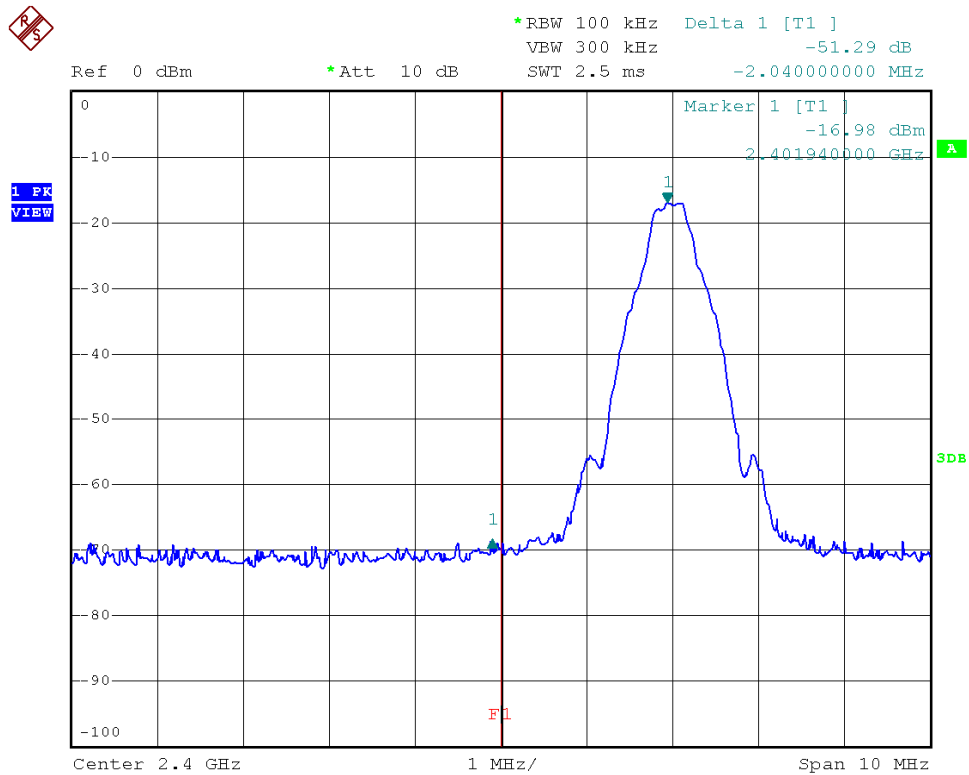

---

## INTERTEK TESTING SERVICES

---

### Peak Measurement (Bluetooth 3.0)

Bandedge compliance is determined by applying marker-delta method, i.e. (Bandedge Plot).

#### Lower bandedge

Peak Resultant field strength = Fundamental emissions (peak value) – delta from the plot

=93.2 dB $\mu$ V/m - 51.3 dB

=41.9 dB $\mu$ V/m

Average Resultant field strength = Fundamental emissions (average value) – delta from the plot

=69.2 dB $\mu$ V/m - 51.3 dB

=17.9 dB $\mu$ V/m

#### Upper bandedge

Peak Resultant field strength = Fundamental emissions (peak value) – delta from the plot

=91.6 dB $\mu$ V/m - 51.2 dB

=40.4 dB $\mu$ V/m

Average Resultant field strength = Fundamental emissions (average value) – delta from the plot

=67.6 dB $\mu$ V/m - 51.2 dB

=16.4 dB $\mu$ V/m

The resultant field strength meets the general radiated emission limit in Section 15.209 / RSS-210 2.5, which does not exceed 74 dB $\mu$ V/m (Peak Limit) and 54 dB $\mu$ V/m (Average Limit).



# INTERTEK TESTING SERVICES

## Peak Measurement (Bluetooth 4.0 BLE)

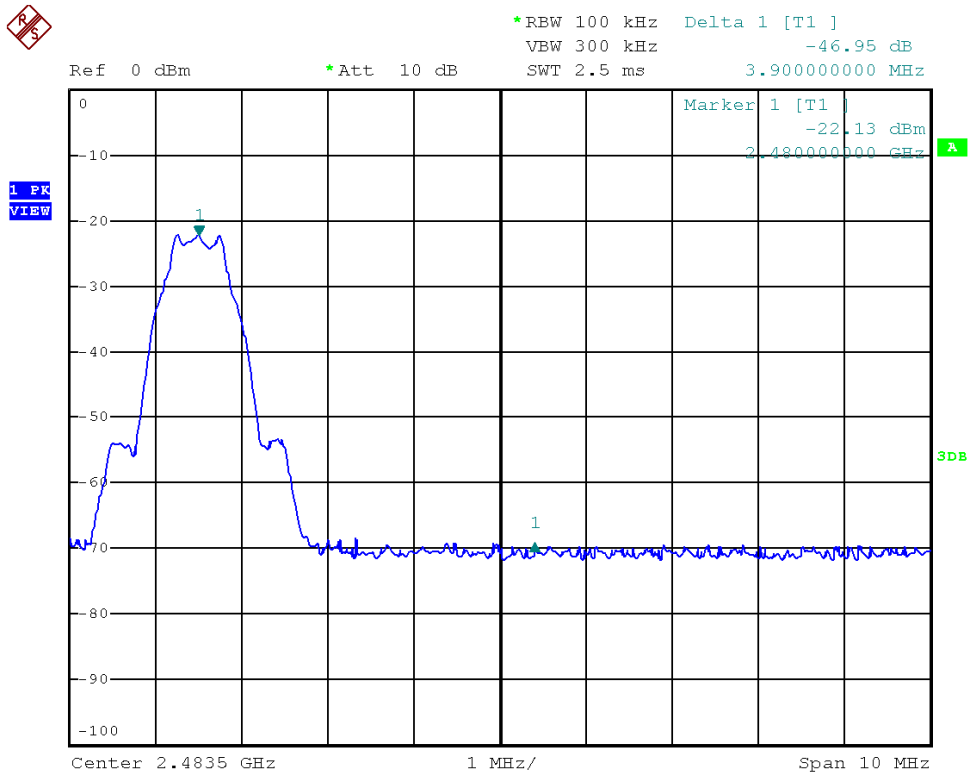
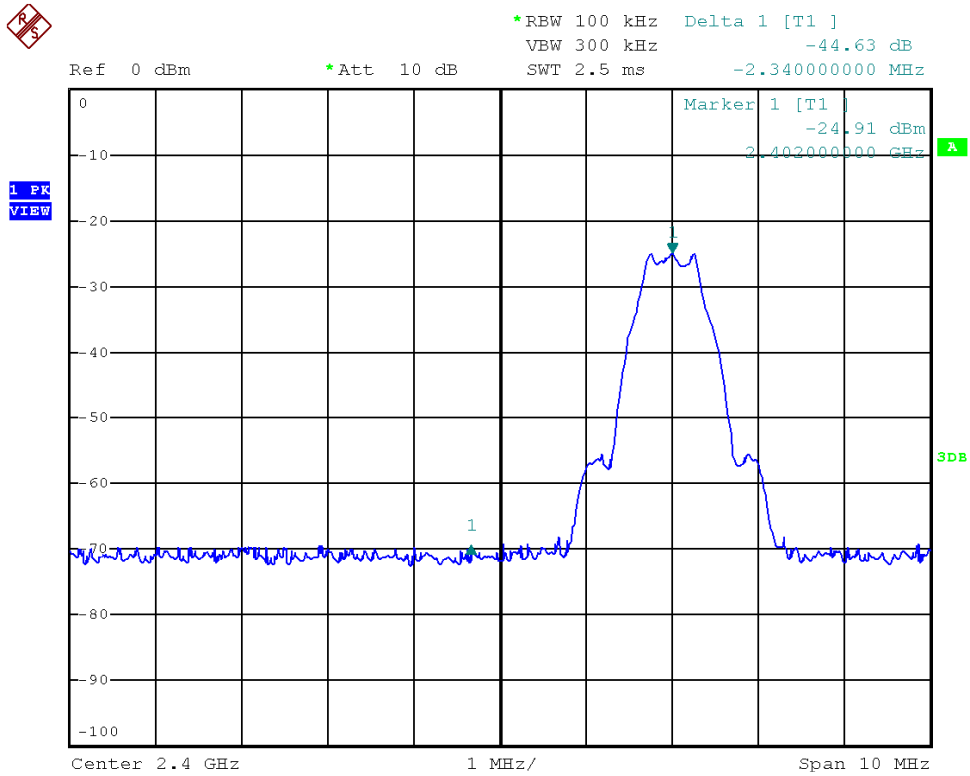

---

## INTERTEK TESTING SERVICES

---

### Peak Measurement (Bluetooth 4.0 BLE)

Bandedge compliance is determined by applying marker-delta method, i.e. (Bandedge Plot).

Lower bandedge

Peak Resultant field strength = Fundamental emissions (peak value) – delta from the plot

=92.2 dB $\mu$ V/m - 44.6 dB

=47.6 dB $\mu$ V/m

Average Resultant field strength = Fundamental emissions (average value) – delta from the plot

=92.2 dB $\mu$ V/m - 44.6 dB

=47.6 dB $\mu$ V/m

Upper bandedge

Peak Resultant field strength = Fundamental emissions (peak value) – delta from the plot

=91.2 dB $\mu$ V/m - 47.0 dB

=44.2 dB $\mu$ V/m

Average Resultant field strength = Fundamental emissions (average value) – delta from the plot

=91.2 dB $\mu$ V/m - 47.0 dB

=44.2 dB $\mu$ V/m

The resultant field strength meets the general radiated emission limit in Section 15.209 / RSS-210 2.5, which does not exceed 74 dB $\mu$ V/m (Peak Limit) and 54 dB $\mu$ V/m (Average Limit).

---

## INTERTEK TESTING SERVICES

---

### 8.2 Discussion of Pulse Desensitization

(Bluetooth 3.0)

Pulse desensitivity is not applicable for this device. The effective period (Teff) is approximately 625µs for a digital "1" bit which illustrated on technical specification, with a resolution bandwidth (3dB) of 1MHz, so the pulse desensitivity factor is 0dB.

(Bluetooth 4.0 BLE)

Pulse desensitivity is not applicable for this device. Since the transmitter transmits the RF signal continuously.

### 8.3 Calculation of Average Factor

(Bluetooth 3.0)

Based on the Bluetooth Specification Version 3.0 + EDR, the transmitter ON time for each timeslot of Bluetooth is 625µs. DH5 has the maximum duty cycle, which consists of 5 continuous Tx slots and 1 Rx slot. Therefore one hopset take  $(5+1) \times 625\mu\text{s} = 3.75\text{ms}$ . For one period for a pseudo-random hopping through at least 20 RF channels in adaptive mode (worse case), it take:  $20 \times 3.75\text{ms} = 75\text{ms}$ .

The dwell time for DH5 is  $5 \times 625\mu\text{s} = 3.125\text{ms}$ .

For the worst case calculation, there are two transmissions might occur in 100ms. Therefore,

$$\begin{aligned}\text{Duty Cycle (DC)} &= \text{Maximum On time in } 100\text{ms}/100\text{ms} \\ &= 3.125\text{ms} \times 2/100\text{ms} \\ &= 0.0625\end{aligned}$$

$$\begin{aligned}\text{Average Factor (AF) of Bluetooth in dB} &= 20 \log_{10} (0.0625) \\ &= -24 \text{ dB}\end{aligned}$$

---

## INTERTEK TESTING SERVICES

---

### 8.4 Emissions Test Procedures

The following is a description of the test procedure used by Intertek Testing Services Hong Kong Ltd. in the measurements of transmitter operating under the Part 15, Subpart C rules.

The transmitting equipment under test (EUT) is placed on a wooden turntable which is four feet in diameter and approximately 0.8m in height above the ground plane for emission measurement at or below 1GHz and 1.5m in height above the ground plane for emission measurement above 1GHz. During the radiated emissions test, the turntable is rotated and any cables leaving the EUT are manipulated to find the configuration resulting in maximum emissions. The EUT is adjusted through all three orthogonal axis to obtain maximum emission levels. The antenna height and polarization are also varied during the testing to search for maximum signal levels. The height of the antenna is varied from one to four meters.

Detector function for radiated emissions is in peak mode. Average readings, when required, are taken by measuring the duty cycle of the equipment under test and subtracting the corresponding amount in dB from the measured peak readings. A detailed description for the calculation of the average factor can be found in Exhibit 8.3.

The frequency range scanned is from the lowest radio frequency signal generated in the device which is greater than 9 kHz to the tenth harmonic of the highest fundamental frequency or 40 GHz, whichever is lower. For line conducted emissions, the range scanned is 150 kHz to 30 MHz.

## INTERTEK TESTING SERVICES

---

### 8.4 Emissions Test Procedures (cont'd)

The EUT is warmed up for 15 minutes prior to the test.

AC power to the unit is varied from 85% to 115% nominal and variation in the fundamental emission field strength is recorded. If battery powered, a new, fully charged battery is used.

Conducted measurements were made as described in ANSI C63.10 (2013).

The IF bandwidth used for measurement of radiated signal strength was 100 kHz or greater when frequency is below 1000 MHz. Where pulsed transmissions of short enough pulse duration warrant, a greater bandwidth is selected according to the recommendations of Hewlett Packard Application Note 150-2. A discussion of whether pulse desensitivity is applicable to this unit is included in this report (See Exhibit 8.1). Above 1000 MHz, a resolution bandwidth of 3 MHz is used.

Transmitter measurements are normally conducted at a measurement distance of three meters. However, to assure low enough noise floor in the forbidden bands and above 1 GHz, signals are acquired at a distance of one meter or less. All measurements are extrapolated to three meters using inverse scaling, unless otherwise reported. Measurements taken at a closer distance are so marked.

## INTERTEK TESTING SERVICES

### 8.4.1 Radiated Emission Test Setup

The figure below shows the test setup, which is utilized to make these measurements.

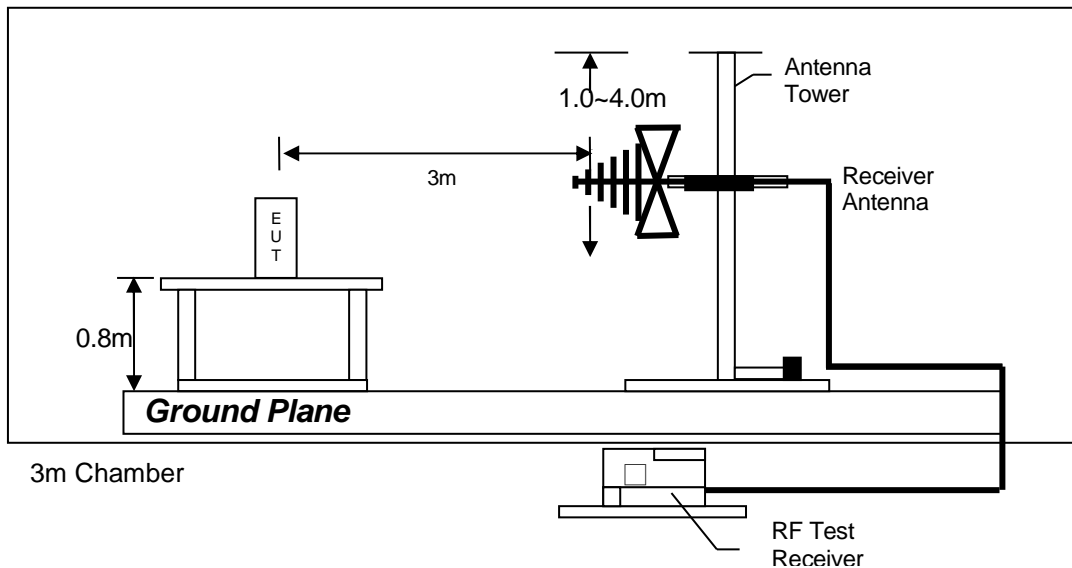

Test setup of radiated emissions up to 1GHz

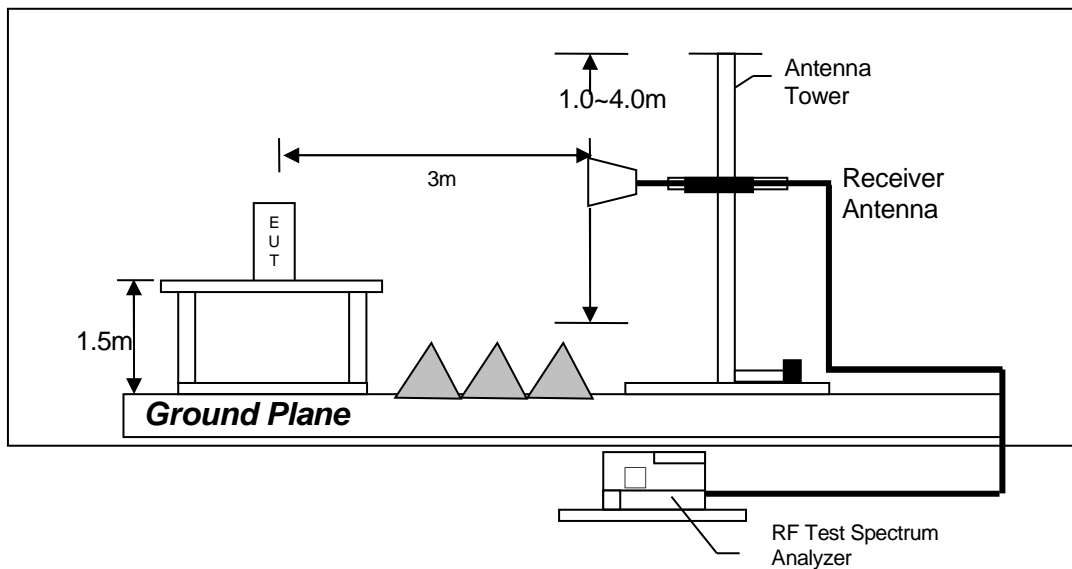

Test setup of radiated emissions above 1GHz

---

## INTERTEK TESTING SERVICES

---

### 8.4.2 Conducted Emission Test Procedures

For tabletop equipment, the EUT along with its peripherals were placed on a 1.0m(W)×1.5m(L) and 0.8m in height wooden table. For floor-standing equipment, the EUT and all cables were insulated, if required, from the ground plane by up to 12 mm of insulating material. The EUT was adjusted to maintain a 0.4 meter space from a vertical reference plane. The EUT was connected to power mains through a line impedance stabilization network (LISN), which provided 50 ohm coupling impedance for measuring instrument and the chassis ground was bounded to the horizontal ground plane of shielded room. The excess power cable between the EUT and the LISN was bundled.

All connecting cables of EUT and peripherals were moved to find the maximum emission.

### 8.4.3 Conducted Emission Test Setup

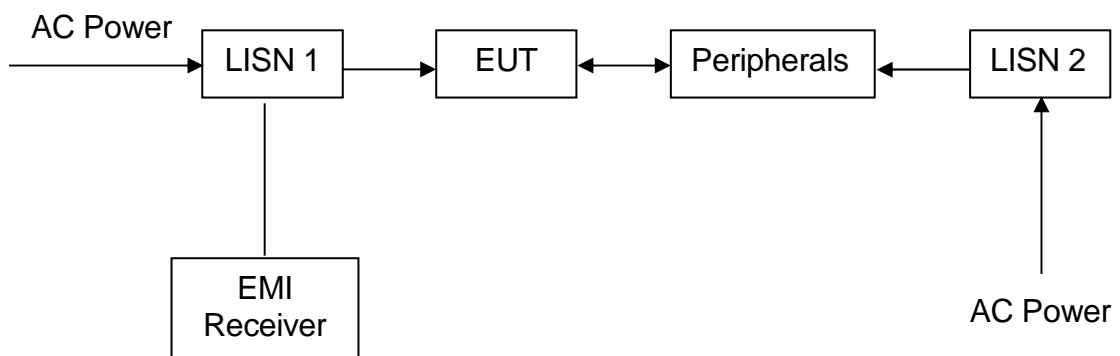

# INTERTEK TESTING SERVICES

## 8.5 Occupied Bandwidth

### Occupied Bandwidth Results: (Bluetooth 3.0)

Bluetooth	Occupied Bandwidth (kHz)
Low Channel: 2402	930
Middle Channel: 2442	930
High Channel: 2480	930

The worst case is shown as below

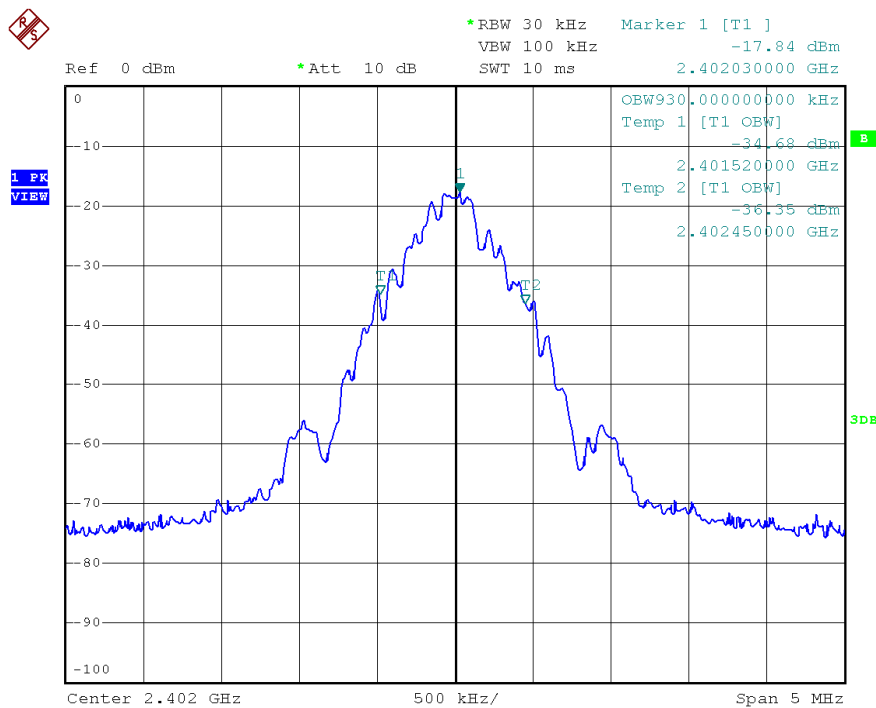



## INTERTEK TESTING SERVICES

### Occupied Bandwidth Results: (Bluetooth 4.0 BLE)

Bluetooth	Occupied Bandwidth (kHz)
Low Channel: 2402	1020
Middle Channel: 2442	1020
High Channel: 2480	1026

The worst case is shown as below

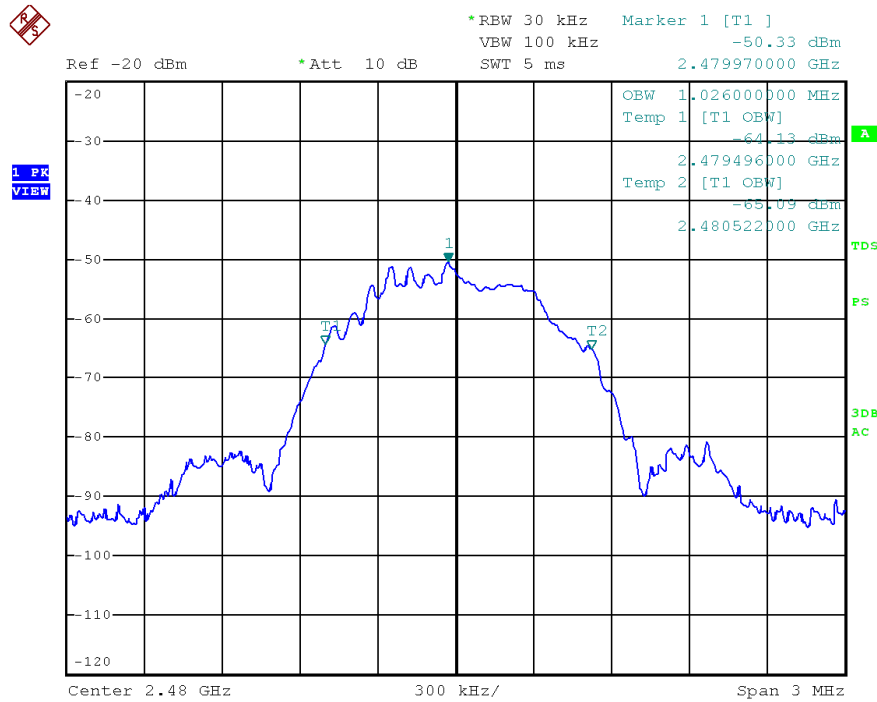

## INTERTEK TESTING SERVICES

---

### 9.0 Equipment List

#### 1) Radiated Emissions Test

Equipment	EMI Test Receiver	Spectrum Analyzer	Biconical Antenna
Registration No.	EW-3156	EW-2188	EW-0571
Manufacturer	R&S	AGILENTTECH	EMCO
Model No.	ESR26	E4407B	3104C
Calibration Date	Nov. 03, 2015	Apr. 25, 2016	Jun. 23, 2015
Calibration Due Date	Nov. 03, 2016	Apr. 25, 2017	Dec. 23, 2016

Equipment	Log Periodic Antenna	Pyramidal Horn Antenna	Double Ridged Guide Antenna
Registration No.	EW-1042	EW-0905	EW-1133
Manufacturer	EMCO	EMCO	EMCO
Model No.	3148	3160-09	3115
Calibration Date	May 21, 2015	Feb. 12, 2016	Nov. 05, 2015
Calibration Due Date	Nov. 21, 2016	Aug. 12, 2017	May 05, 2017

#### 2) Conducted Emissions Test

Equipment	EMI Test Receiver	LISN
Registration No.	EW-2500	EW-2501
Manufacturer	R&S	R&S
Model No.	ESCI	ENV-216
Calibration Date	Jan. 28, 2016	Jan. 28, 2016
Calibration Due Date	Jan. 28, 2017	Jan. 28, 2017

#### 3) Bandedge Measurement

Equipment	Spectrum Analyzer
Registration No.	EW-2249
Manufacturer	R&S
Model No.	FSP30
Calibration Date	Nov. 27, 2015
Calibration Due Date	Nov. 27, 2016

END OF TEST REPORT