



# Home Theater Sound Bar with Subwoofer

RTS7340SB  
User Manual



It is important to read this user manual prior to using your new product for the first time.

## SAFETY PRECAUTIONS

### FCC INFORMATION

This device complies with Part 15 of the FCC rules. Operation is subject to the following two conditions:

- (1) This device may not cause harmful interference, and
- (2) This device must accept any interference received, including interference that may cause undesired operation.

NOTE: This equipment has been tested and found to comply with the limits for a Class B digital device, pursuant to part 15 of the FCC Rules. These limits are designed to provide reasonable protection against harmful interference in a residential installation. This equipment generates, uses, and can radiate radio frequency energy and, if not installed and used in accordance with the instructions, may cause harmful interference to radio communications. However, there is no guarantee that interference will not occur in a particular installation. If this equipment does cause harmful interference to radio or television reception, which can be determined by turning the equipment off and on, the user is encouraged to try to correct the interference by one or more of the following measures:

- Reorient or relocate the receiving antenna.
  - Increase the separation between the equipment and receiver.
  - Connect the equipment into an outlet on a circuit different from that to which the receiver is connected.
  - Consult the dealer or an experienced radio/TV technician for help.
- WARNING: Changes or modifications to this unit not expressly approved by the party responsible for compliance could void the user's authority to operate the equipment.

### FOR CUSTOMERS IN CANADA

This apparatus complies with the Class B limits for radio noise emission set out in radio interference regulations.

CAN ICES-3 (B) / NMB-3 (B)

### Warning:

- The AC adapter is used as disconnect device and it should remain readily operable during intended use. In order to disconnect the unit from the mains completely, the AC adapter should be disconnected from the mains socket outlet completely.
- The AC adapter of unit should not be obstructed OR should be easily accessed during intended use.
- Minimum 10 cm (4 inches) distances around the unit for sufficient ventilations.
- The ventilation should not be impeded by covering the ventilation openings with items such as newspaper, table-cloths, curtains, etc.
- No naked flame sources such as lighted candles should be placed on the unit.

### ON SAFETY

- Should any objects or liquids fall into the unit, disconnect the power supply and have the unit checked by qualified personnel before any further operation.
- The unit shall not be exposed to dripping or splashing and that no objects filled with liquid, such as vases, shall be placed on the unit.

### ON USE

- Never use the unit where it would be subject to:
- Heat sources such as radiators or air ducts.
- Direct sunlight.

## LOCATION OF CONTROLS

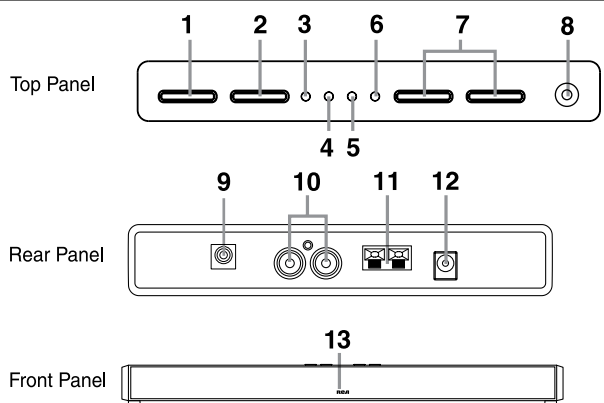

1. STANDBY/ON button
2. SOURCE button
3. BLUETOOTH button / LEVEL indicator
4. AUX IN / LEVEL indicator
5. OPTICAL IN / LEVEL indicator
6. LINE IN / LEVEL indicator
7. VOLUME +/- button
8. LINE IN 3.5mm jack
9. OPTICAL IN jack
10. AUX IN L / R jack
11. DC IN jack
12. Subwoofer speaker terminal
13. Remote Sensor

### REMOTE CONTROL

1. MUTE button
2. BLUETOOTH button
3. VOL +/- button
4. AUX button
5. BASS +/- button
6. MUTE button
7. LINE IN button
8. OPTICAL button
9. TREBLE +/- button
10. SOURCE +/- button

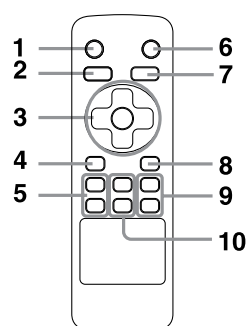

## ACCESSORIES

Please locate the included accessories. To order replacement units, visit <http://www.RCAav.com>

- Remote control (with 2 x AAA batteries)..... x 1
- AC power adapter..... x 1
- Audio Cable..... x 1

## POWER SUPPLY

### USING THE AC ADAPTER

Using an AC adapter other than the one supplied with the unit may damage the unit.

### Caution:

- Before use, ensure the rated voltage of the adapter matches your local voltage.
- The included AC adapter is for use with this unit only. Do not use it with other equipment.
- If you are not going to use the unit for a long time, disconnect the AC adapter from the wall outlet.
- Whenever the AC adapter is plugged in to a wall outlet, the AC adapter will draw some power, even when the Sound Bar is turned off.

## REMOTE CONTROL

### USING THE REMOTE CONTROL

- Point the remote control at the REMOTE SENSOR located on the unit (see Front Panel illustration for precise location).
- When there is a strong ambient light source, the performance of the infrared REMOTE SENSOR may be degraded, causing unreliable operation.
- The recommended effective distance for remote operation is about 16 feet (5 meters).

### TO CHANGE REMOTE BATTERIES

1. Open the battery door.
2. Insert two AAA batteries.



### BATTERY REPLACEMENT

When the batteries become weak, the operating distance of the remote control is greatly reduced and you will need to replace them.

### Notes:

- If the remote control is not going to be used for a long time, remove the batteries to avoid corrosion damage caused by battery leakage.
- Do not mix old and new batteries. Do not mix ALKALINE, standard (CARBON-ZINC) or rechargeable (NICKEL-CADMIUM) batteries.
- Always remove batteries as soon as they become weak.
- Weak batteries can leak and severely damage the remote control.
- WARNING: Do not dispose of batteries in a fire. batteries may explode or leak.

### CAUTION:

Danger of explosion if battery is incorrectly replaced. Replace only with the same or equivalent type.

## PLACEMENT

The Soundbar can be placed freestanding on a table or mounted on a wall.

### PLACING THE SOUNDBAR ON A WALL

The Soundbar requires additional mounting hardware that must be purchased separately.

1. Place the Wall Mount Template (supplied) on the wall and then mark the locations of the screw holes.
2. Drill the screws (not supplied) into the wall carefully.
3. Gently hang the Soundbar onto the screws in the wall.

### Note:

Allow 2mm space between screw and the wall for fitting the wall mount bracket.

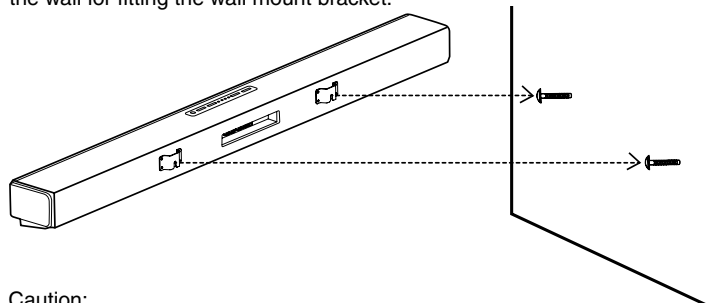

### Caution:

- We recommend that Wall-mounting be carried out by a professional. The wall mount bracket "key-holes" are intended for use with #8 (Imperial) or M4 (Metric) with head size: Diameter 7.5 - 9.4 mm. Additional or alternative parts may be needed for certain types of wall constructions.
- Make sure that the wall-mount is fixed securely enough so that it meets safety standards.
- Allow at least 2" (5 cm) separation in all directions between the Sound Bar and other AV equipment (such as your TV or Set-Top Box).
- It is recommended that all cables (AC adapter and Audio cables) be connected to the Sound Bar before placing it on the wall.

## BASIC OPERATION

1. Press STANDBY/ON button on the Soundbar or MUTE button on the remote to turn on the unit.
2. Press SOURCE button on the remote to select AUX IN, OPTICAL IN, LINE IN or Bluetooth source (input). The LEDs located on top of Sound Bar will indicate the currently-selected source.
3. Press VOLUME +/-, BASS +/- or TREBLE +/- on the remote to adjust Volume, Bass or Treble levels. When adjusting Volume, Bass or Treble, the four LEDs will temporarily display the current level setting (see illustration below).

Note: When mute is enabled, the 4 LED indicators will flash. Press the MUTE button on the remote control to disable the mute function and LED flashing stop.

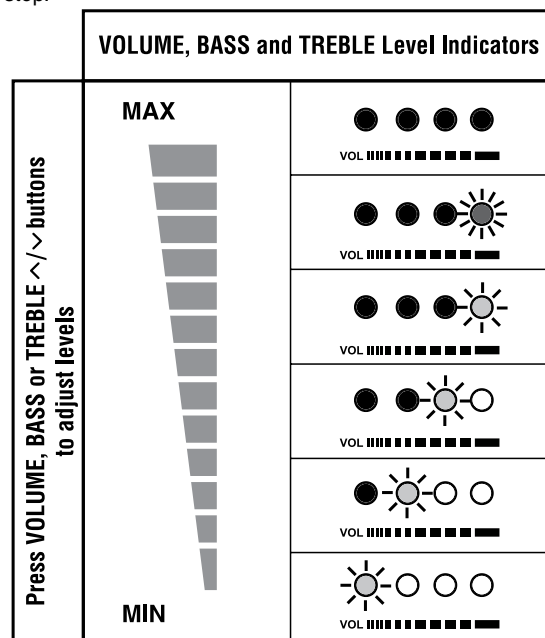

## CONNECTIONS

### CONNECT THE SUBWOOFER

Press down the tab to open the terminal and insert the wire. Release the tab to lock on the uninsulated part of the wire in the terminal. Be sure to match connector colors.

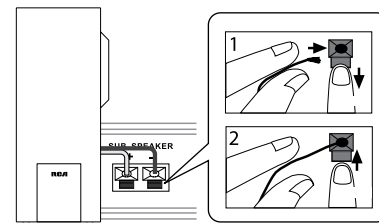

### POSITIONING THE SUBWOOFER

It is not recommended to place the subwoofer near the TV set. Place the subwoofer at least 12" away from the TV.

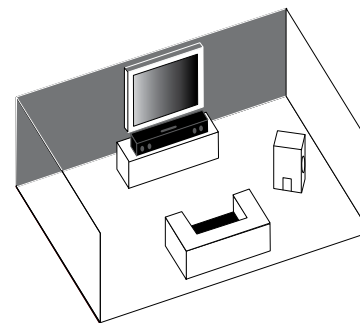

### CONNECT AUDIO THROUGH A DIGITAL OPTICAL CABLE

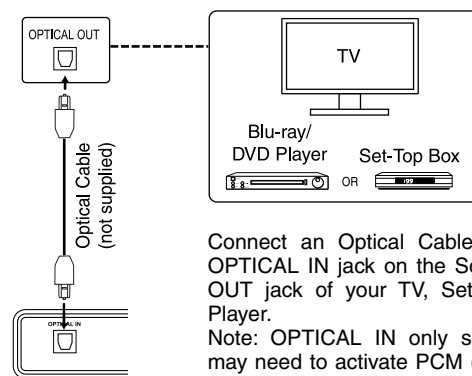

Connect an Optical Cable (not supplied) from the OPTICAL IN jack on the Sound Bar to the OPTICAL OUT jack of your TV, Set-Top Box or Blu-ray/DVD Player.

Note: OPTICAL IN only supports PCM signal. You may need to activate PCM (Downmix) on your source device, e.g. TV, Set-Top Box or Blu-ray/DVD Player.

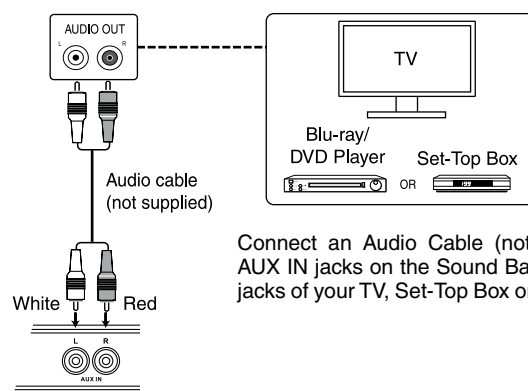

Connect an Audio Cable (not supplied) from the AUX IN jacks on the Sound Bar to the AUDIO OUT jacks of your TV, Set-Top Box or Blu-ray/DVD Player.

### CONNECT AUDIO THROUGH AN ANALOG AUDIO CABLE

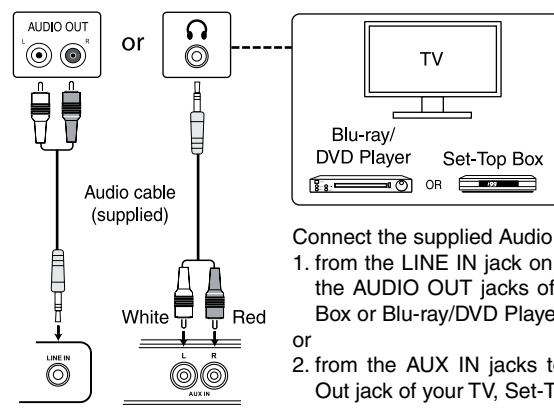

### Connect the supplied Audio Cable:

1. from the LINE IN jack on the Sound Bar to the AUDIO OUT jacks of your TV, Set-Top Box or Blu-ray/DVD Player.
- or
2. from the AUX IN jacks to the Headphone Out jack of your TV, Set-Top Box or Blu-ray/DVD Player.

Plug one end of a 3.5mm Audio Cable (not included) into the LINE IN jack (top panel) on the Sound Bar and other end into your iPad®, iPhone®, iPod® or other audio devices.

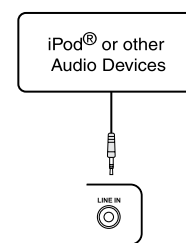

## BLUETOOTH PAIRING

Before Bluetooth pairing, you should turn on the Bluetooth function of your other device (such as, mobile phone with Bluetooth function).

1. Press SOURCE button on the unit or BT button on the remote control to select BT (Bluetooth) mode. The Bluetooth indicator light on the soundbar will blink.
2. On your device (mobile phone, MP3 player, etc.), select **RCA RTS7220B-2** from the list of available Bluetooth connections. Note: If your Bluetooth device (such as, mobile phone) requires a password while pairing, please enter 4-digit number: 0000.

- If the Bluetooth pairing is successful, the Bluetooth indicator will illuminate.
- If the Bluetooth pairing is unsuccessful, the Bluetooth indicator will blink at slow speed. Please try again.

### ENJOY THE MUSIC THROUGH BLUETOOTH

- Press PAUSE button to begin or pause playback
- Press REWIND/FAST FORWARD button to select a specific track
- Press and hold REWIND/FAST FORWARD button to start moving backward/forward at high speed.

## TROUBLESHOOTING

PROBLEMS	SOLUTIONS
The unit does not switch on.	<ul style="list-style-type: none"> <li>• Make sure it is plugged in.</li> <li>• Press STANDBY/ON button to turn on the Sound Bar.</li> </ul>
I have no sound.	<ul style="list-style-type: none"> <li>• Press the VOLUME +/- button on the top of the Sound Bar or VOL +/- button on the remote.</li> <li>• Ensure the source you've selected is outputting audio. If you're using "audio out" from your TV, ensure your TV is configured to output audio (see TV's menu settings).</li> <li>• Ensure your AV connections are properly made (ensure you don't have any loose connections).</li> <li>• Ensure you've selected the correct source (input) - the LEDs located on the top of the Sound Bar will indicate the currently-selected source (input).</li> <li>• Mute is activated (the 4 LEDs on top of the Sound Bar flashes). Press the mute button on the remote control.</li> <li>• Ensure the input source is selected PCM output on the setup menu of the input device.</li> </ul>
Cannot setup Bluetooth pairing	<ul style="list-style-type: none"> <li>• Reset the bluetooth connection by turning off and on your connectind device, or this Sound Bar, or select other SOURCE on this Soundbar then back to BT mode again.</li> </ul>
The remote control doesn't work	<ul style="list-style-type: none"> <li>• If battery is weak, please replace the battery and ensure the new battery is installed correctly.</li> <li>• Please ensure there is nothing blocking the remote sensor on the front of the Sound Bar.</li> </ul>

Specifications and external appearance are subject to change without notice.

## LIMITED WARRANTY

AVC MULTIMEDIA ("AVC") makes the following limited warranty. This limited warranty extend to the original consumer purchaser and is limited to non-commercial use of the product.

### ONE YEAR PARTS & LABOR WARRANTY

AVC products purchased in the United States are warranted to be free from defects in materials or workmanship for a period of one year from the date of their original retail purchase. If the unit fails to conform to this warranty, we will service the product using new or refurbished parts and products, at AVC's sole discretion.

During a period of one year from the effective warranty date, AVC will provide, when needed, service labor to repair a manufacturing defect at its designated Service Center. To obtain warranty service in the United States, you must first call our Customer Support Center at 1-800-506-5746 or 1-877-252-6873, during the hours listed in the box below. The determination of service will be made by AVC Customer Support. PLEASE DO NOT RETURN YOUR UNIT TO AVC WITHOUT PRIOR AUTHORIZATION. New or remanufactured replacements for defective parts or products will be used for repairs by AVC at its designated Service Center for one year from the effective warranty date. Such replacement parts or products are warranted for an additional one year from the date of repair or replacement. The Customer will be required to ship the unit to the Service Center indicated at the time Customer Support is contacted to make the necessary repairs. The customer is responsible for all transportation charges to the service facility.

### PACKAGING AND SHIPPING INSTRUCTION

When you send the product to the AVC service facility you must use the original carton box and packing material or an equivalent as designated by AVC.

### LIMITED WARRANTY

### YOUR RESPONSIBILITY

- (1) You must retain the original sale receipt to provide proof of purchase.
- (2) These warranties are effective only if the product is purchased and operated in the U.S.A. or Canada.
- (3) Warranties extend only to defects in material or workmanship, and do not extend to any product or parts which have been lost or discarded, or damage to product or parts caused by misuse, accident, improper operation or maintenance, or use in violation of instructions provided with the product, or to product which has been altered or modified without authorization of AVC, or to products or parts thereof which have had the serial number removed or changed.

### OUT OF WARRANTY

In the event your product requires repair after the limited warranty period has expired, please contact our Customer Support Center at 1-800-506-5746, 1-877-252-6873 or [www.RCAav.com](http://www.RCAav.com)  
Hours: Monday–Thursday: 9am–7pm, Friday: 9am–5pm, Saturday: 9am–NOON Eastern time.  
Important: You are responsible for any transportation, shipping or insurance relative to the return of product to our Product Returns Center.

All warranties implied by state law, including the implied warranties of merchantability and fitness for a particular purpose, are expressly limited to the duration of the limited warranties set forth above. With the exception of any warranties implied by state law as hereby limited, the foregoing warranty is exclusive and in lieu of all other warranties, guarantees, agreements and similar obligations of manufacturer or seller with respect to the repair or replacement of any parts. In no event shall AVC be liable for consequential or incidental damages. No person, agent, distributor, dealer or company is authorized to change, modify or extend the terms of these warranties in any manner whatsoever. The time within action must be commenced to enforce any obligation of AVC arising under the warranty or under any statute, or law of the United States or any state thereof, is hereby limited to one year from the date of purchase. This limitation does not apply to implied warranties arising under state law. This warranty gives you specific legal rights and you may also have other rights, which may vary, from state to state. Some states do not allow limitation on how long an implied warranty lasts, when an action may be brought, or the exclusion or limitation of incidental or consequential damages, so the above provisions may not apply to you.

For more information on other products and services, please visit our web site at [www.RCAav.com](http://www.RCAav.com).

Important: Also keep your "Bill of Sale" as proof of purchase.

Serial no ..... Invoice no .....

Date purchased ..... Dealer name .....

FOR SERVICE AND REPAIR, PLEASE VISIT [www.RCAav.com](http://www.RCAav.com).

**Need more help?**  
Please visit online help at [www.RCAav.com](http://www.RCAav.com)