

ALCO CONFIDENTIAL

REVISION NO.	DESCRIPTION	DATE	BY
1	INITIAL DESIGN	1988-08-15	J. W. HARRIS
2	REVISED FOR MANUFACTURE	1988-09-15	J. W. HARRIS
3	REVISED FOR MANUFACTURE	1988-10-15	J. W. HARRIS
4	REVISED FOR MANUFACTURE	1988-11-15	J. W. HARRIS
5	REVISED FOR MANUFACTURE	1989-01-15	J. W. HARRIS
6	REVISED FOR MANUFACTURE	1989-02-15	J. W. HARRIS
7	REVISED FOR MANUFACTURE	1989-03-15	J. W. HARRIS
8	REVISED FOR MANUFACTURE	1989-04-15	J. W. HARRIS
9	REVISED FOR MANUFACTURE	1989-05-15	J. W. HARRIS
10	REVISED FOR MANUFACTURE	1989-06-15	J. W. HARRIS

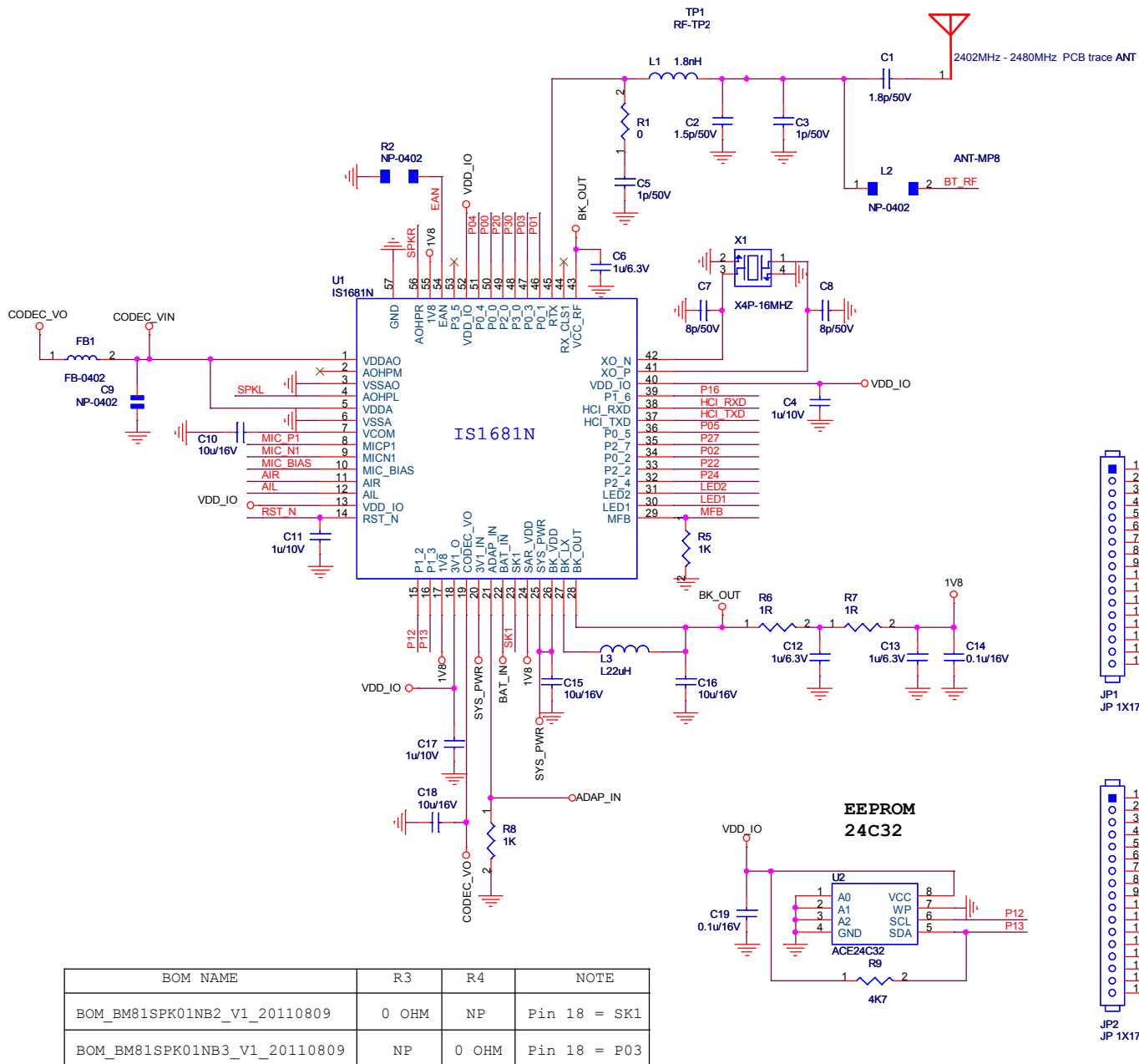

PIN DEFINITION

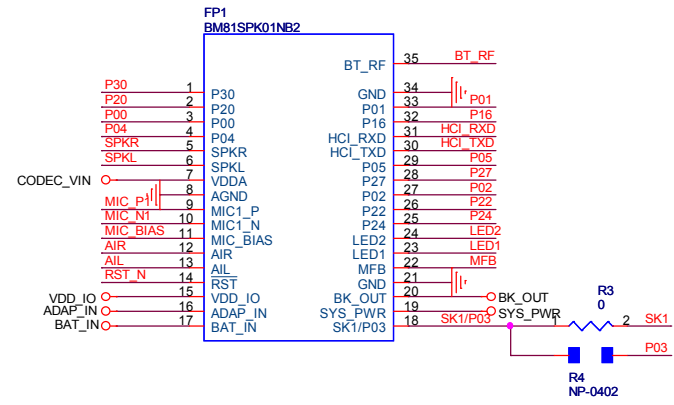

GPIO Description

Pin	Description
P00	Slide Switch Detect/TX_IND
P01	Volume up
P02	Play/Pause
P03	RX_IND
P04	Audio AMP Enable
P05	REV
P16	Volume down
P20	System Configuration
P22	Keep alive for external LDO
P24	System Configuration
P27	FWD
P30	Line-in detect

BOM NAME	R3	R4	NOTE
BOM_BM81SPK01NB2_V1_20110809	0 OHM	NP	Pin 18 = SK1
BOM_BM81SPK01NB3_V1_20110809	NP	0 OHM	Pin 18 = P03

ISSC Technologies Corp.
 ADD. 4F, No.8, Dusing Rd., Hsinchu Science Park,
 Hsinchu City 30078, Taiwan
 TEL. 886-3-5778385

Board Name		BM81SPK01NB2 / BM81SPK01NB3	P/N
Size	Title	SCH_BM81SPK01NB2_V1_20110809	Rev
B		SCH_BM81SPK01NB3_V1_20110809	V1
Date:	Monday, November 07, 2011	Sheet	1 of 1



THESE SPECIFICATION ARE THE PROPERTY OF GENESIS SCIENCE TECHNOLOGY LIMITED, AND SHALL NOT BE REPRODUCED OR USED AS THE BASIS FOR THE MANUFACTURE OR SELL OF APPARATUSES OR DEVICES WITHOUT PERMISSION.

Model No.:
GT-WAAL13000180-302
P/N:2012-000017

5. SCHEMATIC of AC/DC ADAPTOR

