

CD6697BL BLOCK DIAGRAM

# Block Diagram

WB9805

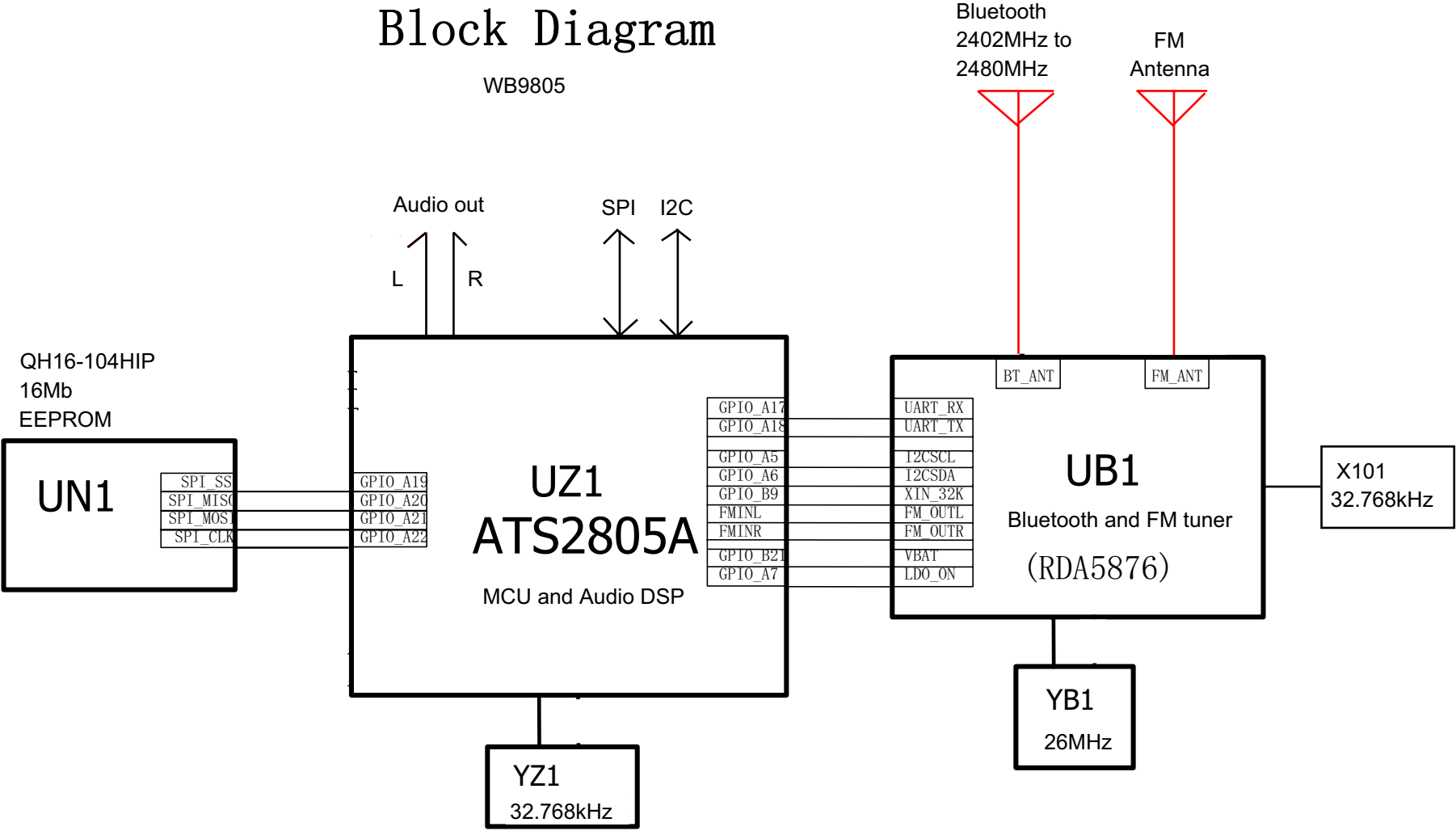

### 3 Bluetooth Section Functional Description

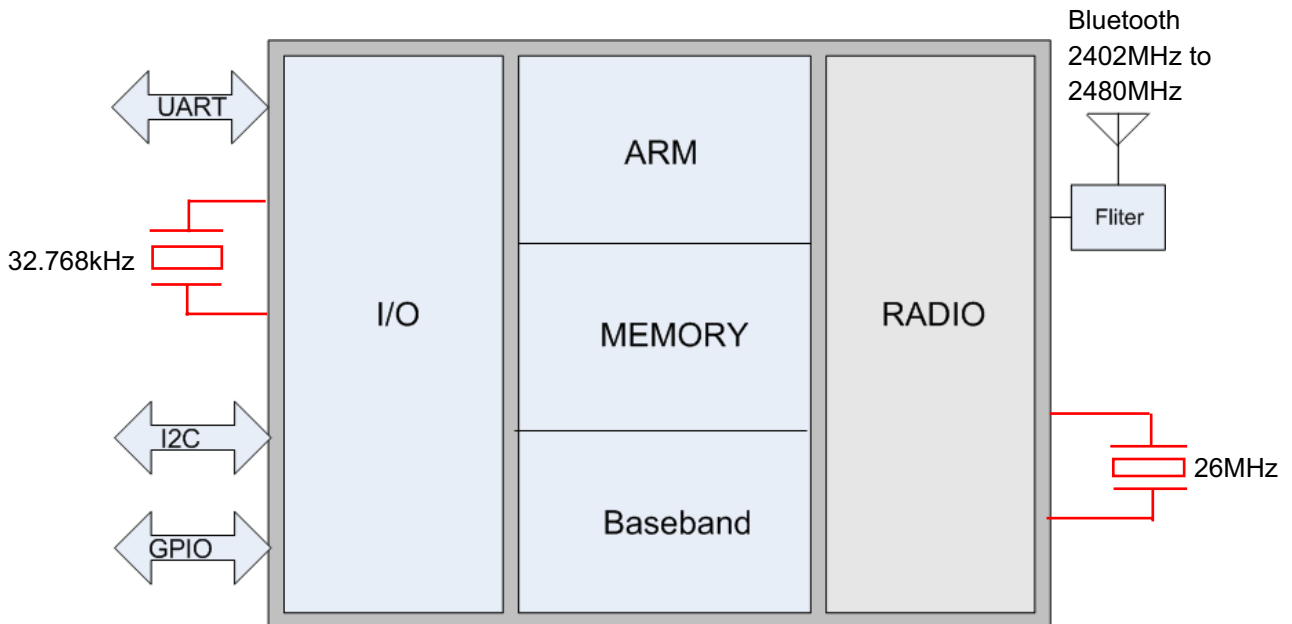

Figure3-1. RDA5876 Bluetooth Block Diagram

RDA5876 is designed for use in UART HCI with handset chipsets. As shown in Figure3-1, RDA5876 integrates radio unit, baseband core, ARM7 core and memory which provides a complete lower Bluetooth protocol stack including the LC, LM and HCI interface.