

Technical Description

The Equipment Under Test (EUT) is a Tablet, equipped with WiFi, SD and USB Interface. The EUT operates in frequency range from 2412MHz to 2462MHz at 802.11b,g,n HT20 (11 channels with 5MHz spacing) while from 2422MHz to 2452MHz at 802.11n HT40 (7 channels with 5MHz channel spacing). The EUT is powered by an external AC/DC adaptor (5VDC output) or/and internal 3.7VDC (2600mAh rechargeable battery). The adaptor accepts 100-120VAC only.

Tablet WiFi (UM12BS) Module

The Tablet WiFi modules was tested in according with the following power output and in actual application the below limit shall not be exceeded.

Operating Mode	Nominal Radiated Field Strength	Production Tolerance
802.11b	100.6dB μ V/m at 3m	\pm 3dB
802.11g	100.4dB μ V/m at 3m	\pm 3dB
802.11n (HT20)	99.8dB μ V/m at 3m	\pm 3dB
802.11n (HT40)	99.7dB μ V/m at 3m	\pm 3dB

An internal, integral antenna has been used.
Antenna Gain: 0dBi

Detail Description of Critical Components

1. WiFi module UM12BS (U19)

UM12BS is an USB WLAN module which fully supports the features and functional compliance of IEEE 802.11b/g/n(HT20)/n(HT40) standards. This module operates in 2.4GHz frequency band.

UM12BS (U19) module consists of

- 1) U6 (RTL8188ETV) is a single-chip IEEE802.11b/g/n 1T1R WLAN controller with PCI (USB) interface.
- 2) XTAL1 (40MHz) crystal provides clock for U6 (RTL8188ETV).
- 3) U21 is 3.3V regulator for U6 (RTL8188ETV).

2. Real-Time-Clock

- 1) U32 (VC8563S) is single chip Real-Time-Clock with Calendar.
- 2) Y3 (32.768kHz) crystal provides clock for U32 (VC8563S).

3. Main Processor and Power Unit

- 1) U1 (RK3026) is dual-core ARM Cortex-A9 processor.
- 2) Y2 (24MHz crystal) provides system clock for U1
- 3) U23 (5056) is single-chip Li-ion battery charger.
- 4) BT2 is internal 2600mAh Li-ion battery.

4. Codec and Interface Unit

- 1) U13 (8302) is 2.5W class D power amplifier driving loudspeaker. The input to this amplifier is downmix to mono.
- 2) U27 (T1443) is analog switch multiplexer for microphone. R134 provides phantom power to the condensor microphone.
- 3) U25 (GSL1680) is touch screen controller of LCD panel. U11 (IA3327) is back-light supply for the LCD display panel. U16, U38 provides dual polarities supply voltages for the display panel.
- 4) U59 (BMA223) is digital triaxial acceleration (3D G-force) sensor. It can sense tilt, motion and shock vibration.

5. Memory Unit

- 1) U3, U6 (2 X K4B4G1646Q) are 256M X 16bit DDR3 memories.
- 2) U4 (TC58TEG6DCJTA00) is 8G NAND Flash memory.

Channel Occupation of UM12BS WiFi Module in 802.11b/g/n standard

Channel (b/g/n20) Frequency (MHz)

1 2412
2 2417
3 2422
4 2427
5 2432
6 2437
7 2442
8 2447
9 2452
10 2457
11 2462

n20 = 802.11n HT20 (20MHz Bandwidth)

Channel (n40) Frequency (MHz)

1 N/A
2 N/A
3 2422
4 2427
5 2432
6 2437
7 2442
8 2447
9 2452
10 N/A
11 N/A

n40 = 802.11n HT40 (40MHz Bandwidth)

802.11n HT40 (40MHz Bandwidth)

RL-UM12BS V1.0

Product Specifications

WLAN 11b/g/n USB module (1T1R)

Version: V1.0

Overview

UM12BS is a WLAN 11n USB module, which fully supports the features and

Functional compliance of IEEE 802.11n,e and i standards. It supports up to

150Mbps high-speed wireless network connections.

It is designed to provide excellent performance with low power Consumption and enhance the advantages of robust system and cost-effective.

It is targeted at competitive superior performance, better power Management applications.

Features

- * Operates in 2.4 GHz frequency bands
- * 1x1 MIMO technology improves effective throughput and range existing 802.11 b/g products
- * Data rates: up to 150Mbps
- * 802.11e-compatible bursting and I standards
- * BPSK, QPSK, 16 QAM, 64 QAM modulation schemes
- * WEP, TKIP, and AES, WPA, WPA2 hardware encryption schemes

General Specification

Model	RL-UM12BS V1.0
Product Name	WLAN 11n USB module
Major Chipset	Realtek RTL8188ETV
Standard	802.11b/g/n, 802.3, 802.3u
Data Transfer Rate	1,2,5.5,6,11,12,18,22,24,30,36,48,54,60,90,120 and maximum of 150Mbps
Modulation Method	BPSK/ QPSK/ 16-QAM/ 64-QAM
Frequency Band	2.4 ~ 2.4835 GHz ISM Band
Spread Spectrum	IEEE 802.11b: DSSS (Direct Sequence Spread Spectrum) IEEE 802.11g/n:OFDM (Orthogonal Frequency Division Multiplexing)
RF Output Power	< 13dBm@11n,< 18dBm@11b,< 14dBm@11g
Operation Mode	Ad hoc, Infrastructure
Receiver Sensitivity	11Mbps -86dBm@8%,54Mbps -73dBm@10%,130Mbps -66dBm@10%
Operation Range	Up to 180 meters in open space
LED	
OS Support	Windows 2000,XP32-64,Vista 32/64,Win7 32/64,Linux,Mac, Android, WIN CE
Security	WEP, TKIP, AES, WPA, WPA2
Interface	USB 2.0
Power Consumption	DC3.3V Maximum power dissipation in 170MA
Operating Temperature	-20 至 +60° C ambient temperature
Storage Temperature	-10 ~ 70°C ambient temperature
Humidity	5 to 90 % maximum (non-condensing)
Dimension	12. 9032 x 12.1920 x 1.6mm (LxWxH) +-0.2MM

Dimensions:

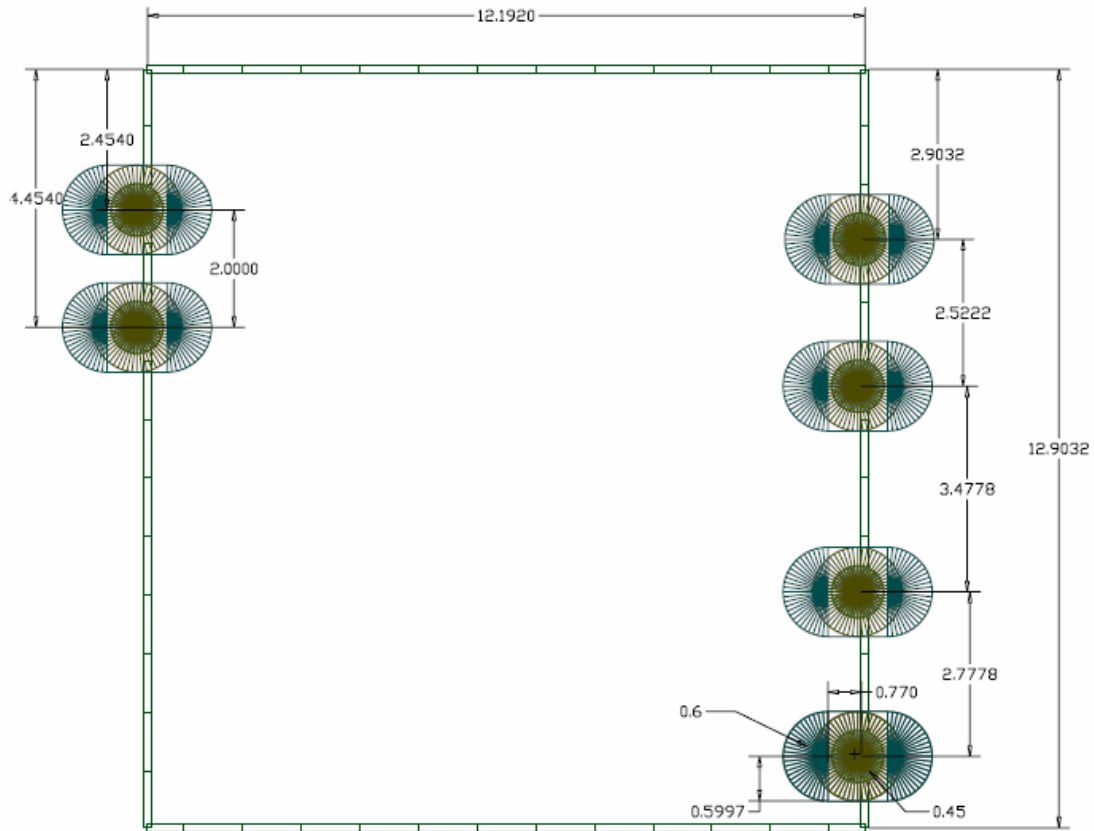

The PCB tolerances within + / -0.2 or so

PIN Definition

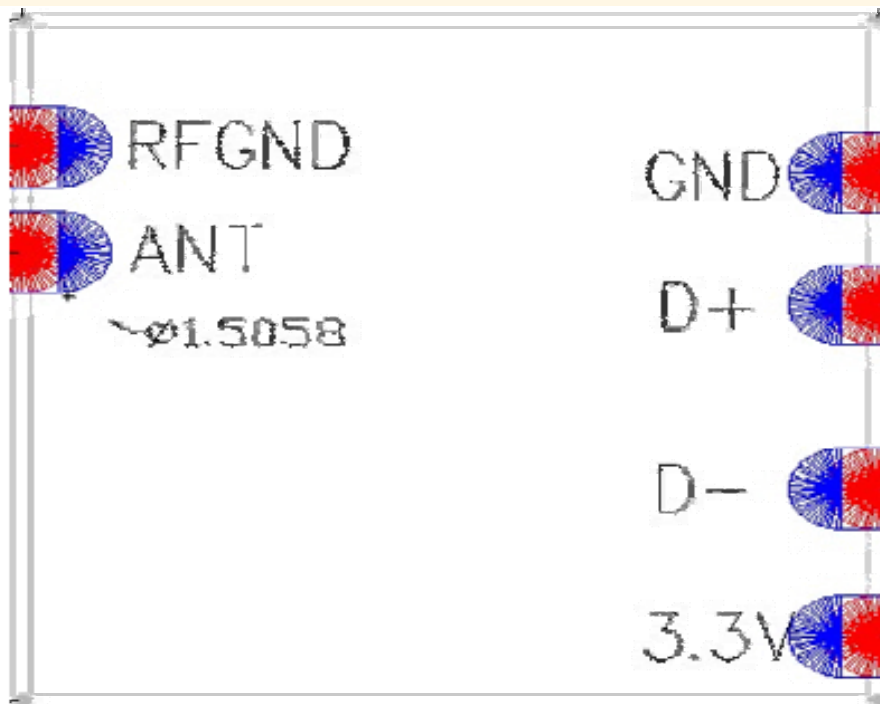

Physical map



注：我司UM12BS有红、黑、蓝、黄四种颜色的板，上图标出一种蓝色供客户参考。

Packaging Appearance Figure

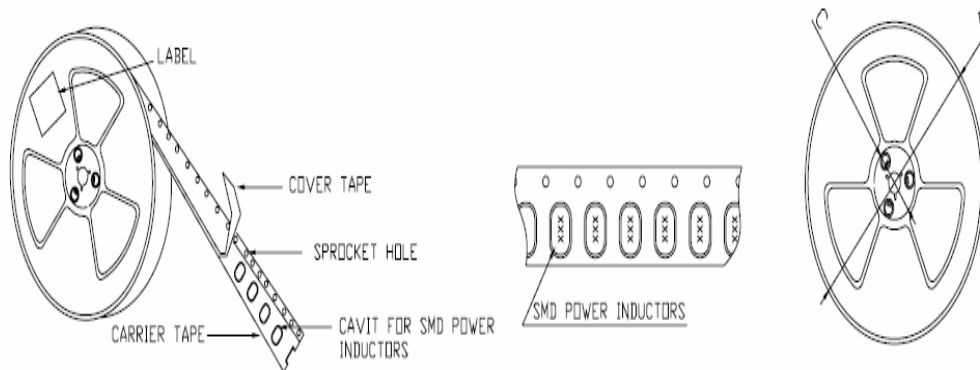

DC Characteristics

Symbol	Parameter	Minimum	Typical	Maximum	Units
VD33A, VD33D	3.3V I/O Supply Voltage	3.1	3.3	3.5	V
VD15A, VD15D	1.5V Supply Voltage	1.4	1.5	1.6	V
IDD33	3.3V Rating Current	-	-	500	mA

Power Consumption

Parameters	Sym	Conditions	Min	Typ	Max	Unit
3.3V Supply Voltage	Vc33		3.1	3.3	3.5	V
1.5V Supply Voltage	Vc15		1.4	1.5	1.6	V
Receiving Tests the biggest receive						
3.3V Current Consumption	Icc33rx	H40MCS7		90		MA
3.3V Current Consumption	Icc33rx	OFDM 54M		100		MA
Transmission Biggest transmission test						
3.3V Current Consumption	Icc33tx	H40 MCS7		140		MA
3.3V Current Consumption	Icc33tx	OFDM 54M		170		MA
The depth waits for an opportunity	Icc33tx/rx			2		MA
Deep sleep	Ic33tx/rx			2		MA



REALTEK

RTL8188ETV

SINGLE-CHIP IEEE 802.11b/g/n 1T1R WLAN

DATASHEET

(CONFIDENTIAL: Development Partners Only)

Rev. 0.1
3 Aug 2012
Track ID:



Realtek Semiconductor Corp.

No. 2, Innovation Road II, Hsinchu Science Park, Hsinchu 300, Taiwan

Tel.: +886-3-578-0211. Fax: +886-3-577-6047

www.realtek.com

COPYRIGHT

©2011 Realtek Semiconductor Corp. All rights reserved. No part of this document may be reproduced, transmitted, transcribed, stored in a retrieval system, or translated into any language in any form or by any means without the written permission of Realtek Semiconductor Corp.

DISCLAIMER

Realtek provides this document “as is”, without warranty of any kind. Realtek may make improvements and/or changes in this document or in the product described in this document at any time. This document could include technical inaccuracies or typographical errors.

TRADEMARKS

Realtek is a trademark of Realtek Semiconductor Corporation. Other names mentioned in this document are trademarks/registered trademarks of their respective owners.

USING THIS DOCUMENT

This document is intended for the software engineer’s reference and provides detailed programming information.

Though every effort has been made to ensure that this document is current and accurate, more information may have become available subsequent to the production of this guide.

REVISION HISTORY

Revision	Release Date	Summary
0.1	2012/08/03	Preliminary release

Table of Contents

1. GENERAL DESCRIPTION	1
2. FEATURES	3
3. APPLICATION DIAGRAM	5
3.1. SINGLE-BAND 11N (1X1) SOLUTION WITH SINGLE ANTENNA	5
3.2. SINGLE-BAND 11N (1X1) SOLUTION WITH DUAL ANTENNA DIVERSITY	6
3.3. SINGLE-BAND 11N (1X1) SOLUTION WITH DUAL ANTENNA	6
4. PIN ASSIGNMENTS	7
4.1. PACKAGE IDENTIFICATION.....	7
5. PIN DESCRIPTIONS	7
5.1. USB BUS TRANSCEIVER INTERFACE	8
5.2. POWER PINS	8
5.3. RF INTERFACE	8
5.4. LED INTERFACE.....	9
5.5. CLOCK AND OTHER PINS.....	10
6. ELECTRICAL AND THERMAL CHARACTERISTICS	11
6.1. TEMPERATURE LIMIT RATINGS.....	11
6.2. DC CHARACTERISTICS.....	11
6.2.1. Power Supply Characteristics	11
6.2.2. Digital IO Pin DC Characteristics.....	11
7. INTERFACE TIMING SPECIFICATION	13
7.1. USB BUS DURING POWER ON SEQUENCE	13
8. MECHANICAL DIMENSIONS	14
8.1. MECHANICAL DIMENSIONS NOTES.....	14
9. ORDERING INFORMATION	15

List of Tables

TABLE 1. USB BUS TRANSCEIVER INTERFACE	8
TABLE 2. POWER PINS.....	8
TABLE 3. RF INTERFACE	8
TABLE 4. LED INTERFACE	9
TABLE 5. CLOCK AND OTHER PINS.....	10
TABLE 6. TEMPERATURE LIMIT RATINGS	11
TABLE 7. DC CHARACTERISTICS	11
TABLE 8. 3.3V GPIO DC CHARACTERISTICS	11
TABLE 9. 2.8V GPIO DC CHARACTERISTICS	11
TABLE 10. 1.8V GPIO DC CHARACTERISTICS	12
TABLE 11. THE TYPICAL TIMING RANGE	13
TABLE 12. ORDERING INFORMATION	15

List of Figures

FIGURE 1. SINGLE-BAND 11N (1X1) SOLUTION	5
FIGURE 2. SINGLE-BAND 11N (1X1) DUAL ANTENNA DIVERSITY SOLUTION	6
FIGURE 3. SINGLE-BAND 11N (1X1) DUAL ANTENNA SOLUTION	7
FIGURE 4. PIN ASSIGNMENTS.....	7
FIGURE 5. RTL8188ETV USB BUS POWER ON SEQUENCE.....	13

1. General Description

The Realtek RTL8188ETV is a highly integrated single-chip 802.11n Wireless LAN (WLAN) network USB interface (USB 1.0/1.1/2.0 compliant) controller. It combines a WLAN MAC, a 1T1R capable WLAN baseband, and WLAN RF in a single chip. The RTL8188ETV provides a complete solution for a high throughput performance integrated wireless LAN device.

The RTL8188ETV WLAN baseband implements Orthogonal Frequency Division Multiplexing (OFDM) with 1 transmit and 1 receive path and is compatible with the IEEE 802.11n specification. Features include one spatial stream transmission, short guard interval (GI) of 400ns, spatial spreading, and transmission over 20MHz and 40MHz bandwidth.

For legacy compatibility, Direct Sequence Spread Spectrum (DSSS), Complementary Code Keying (CCK) and OFDM baseband processing are included to support all IEEE 802.11b and 802.11g data rates. Differential phase shift keying modulation schemes, DBPSK and DQPSK with data scrambling capability, are available, and CCK provides support for legacy data rates, with long or short preamble. The high-speed FFT/IFFT paths, combined with BPSK, QPSK, 16QAM, and 64QAM modulation of the individual subcarriers and rate compatible punctured convolutional coding with coding rate of 1/2, 2/3, 3/4, and 5/6, provide higher data rates of 54Mbps and 150Mbps for IEEE 802.11g and 802.11n OFDM respectively.

The RTL8188ETV WLAN Controller builds in an enhanced signal detector, an adaptive frequency domain equalizer, and a soft-decision Viterbi decoder to alleviate severe multi-path effects and mutual interference in the reception of multiple streams.

Efficient IQ-imbalance, DC offset, phase noise, frequency offset, and timing offset compensations are provided for the radio frequency front-end. Selectable digital transmit and receive FIR filters are provided to meet transmit spectrum mask requirements and to reject adjacent channel interference, respectively.

The RTL8188ETV WLAN Controller supports fast receiver Automatic Gain Control (AGC) with synchronous and asynchronous control loops among antennas, antenna diversity functions, and adaptive transmit power control function to obtain the better performance in the analog portions of the transceiver.

The RTL8188ETV WLAN MAC supports 802.11e for multimedia applications, 802.11i for security, and 802.11n for enhanced MAC protocol efficiency. Using packet aggregation techniques such as A-MPDU with

BA and A-MSDU, protocol efficiency is significantly improved. Power saving mechanisms such as Legacy Power Save, and U-APSD, reduce the power wasted during idle time, and compensates for the extra power required to transmit OFDM. The RTL8188ETV provides simple legacy and 20MHz/40MHz co-existence mechanisms to ensure backward and network compatibility.

2. Features

General

- 46-pin QFN
- CMOS MAC, Baseband PHY, and RF in a single chip for IEEE 802.11b/g/n compatible WLAN
- Complete 802.11n solution for 2.4GHz band
- 72.2Mbps receive PHY rate and 72.2Mbps transmit PHY rate using 20MHz bandwidth
- 150Mbps receive PHY rate and 150Mbps transmit PHY rate using 40MHz bandwidth
- Compatible with 802.11n specification
- Backward compatible with 802.11b/g devices while operating in 802.11n mode

Interface

- Complies with USB 1.0/1.1/2.0 for WLAN

Standards Supported

- IEEE 802.11b/g/n compatible WLAN
- IEEE 802.11e QoS Enhancement (WMM)
- 802.11i (WPA, WPA2). Open, shared key, and pair-wise key authentication services

WLAN MAC Features

- Frame aggregation for increased MAC efficiency (A-MSDU, A-MPDU)
- Low latency immediate High-Throughput Block Acknowledgement (HT-BA)
- PHY-level spoofing to enhance legacy compatibility

- Power saving mechanism
- Channel management and co-existence
- Transmit Opportunity (TXOP) Short Inter-Frame Space (SIFS) bursting for higher multimedia bandwidth

WLAN PHY Features

- IEEE 802.11n OFDM
- One Transmit and one Receive path (1T1R)
- 20MHz and 40MHz bandwidth transmission
- Short Guard Interval (400ns)
- DSSS with DBPSK and DQPSK, CCK modulation with long and short preamble
- OFDM with BPSK, QPSK, 16QAM, and 64QAM modulation.
Convolutional Coding Rate: 1/2, 2/3, 3/4, and 5/6
- Maximum data rate 54Mbps in 802.11g and 150Mbps in 802.11n
- Hardware antenna diversity in per packet base
- Selectable receiver FIR filters
- Programmable scaling in transmitter and receiver to trade quantization noise against increased probability of clipping
- Fast receiver Automatic Gain Control (AGC)
- On-chip ADC and DAC

Peripheral Interfaces

- General Purpose Input/Output (7 pins)
- Three configurable LED pins

3. Application Diagram

3.1. Single-Band 11n (1x1) Solution with Single Antenna

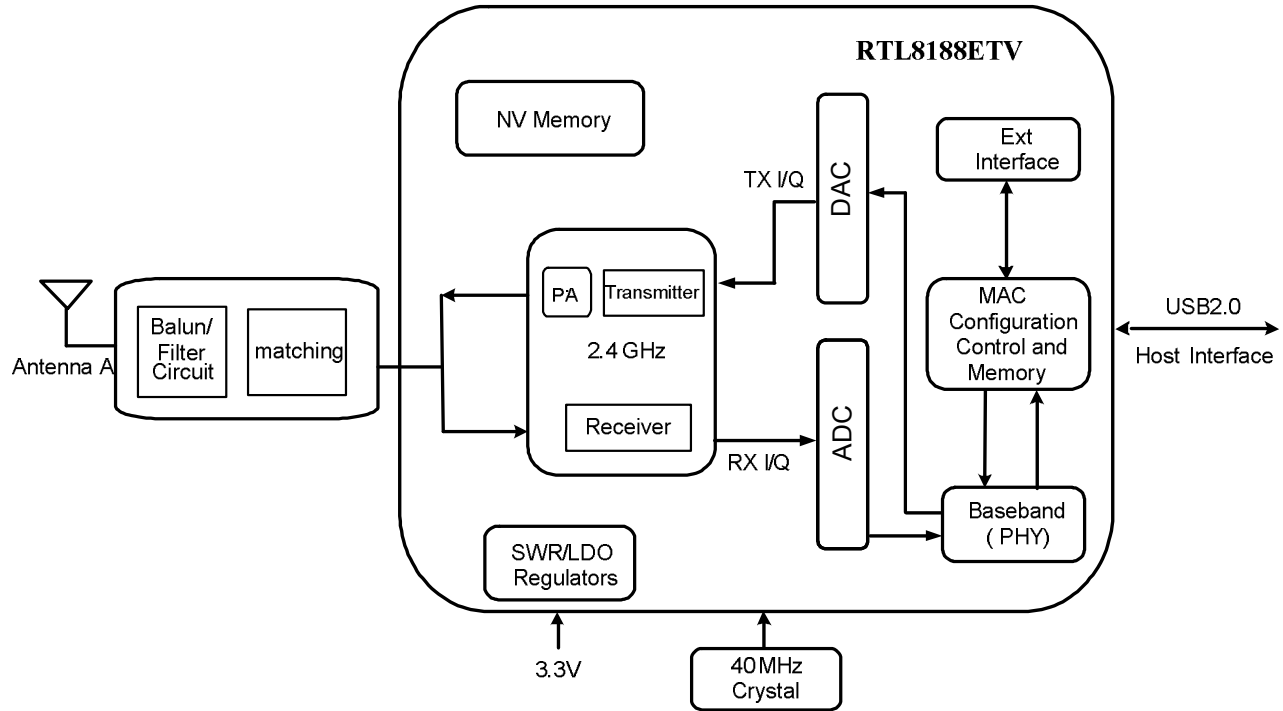

Figure 1. Single-Band 11n (1x1) Solution

3.2. Single-Band 11n (1x1) Solution with Transmit & Receive Diversity

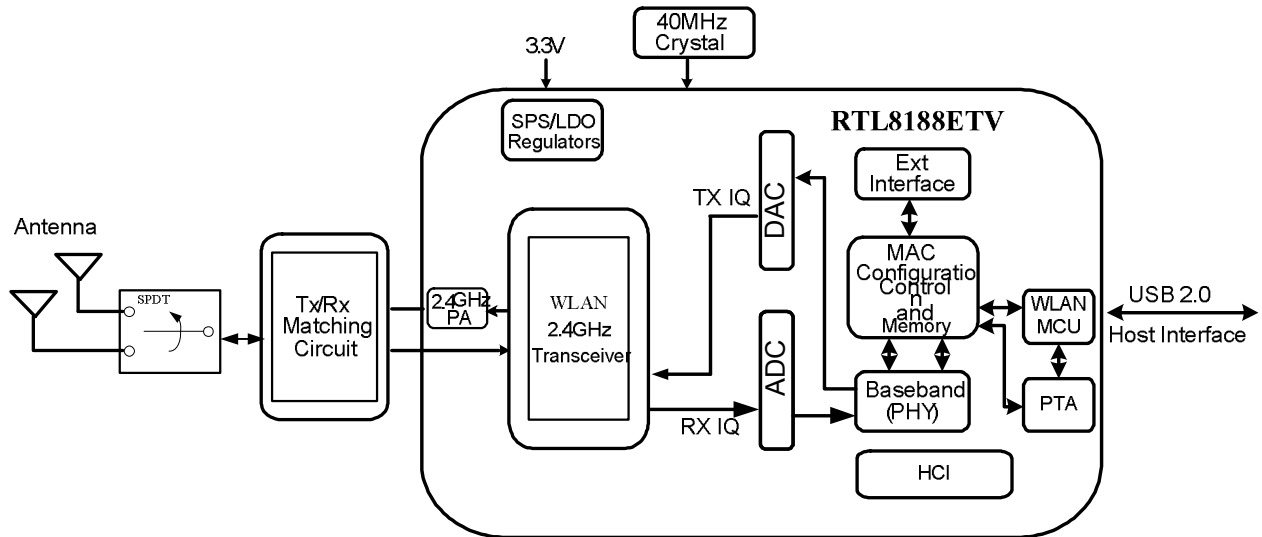

Figure 2. Single-Band 11n (1x1) Transmit & Receive Diversity solution

3.3. Single-Band 11n (1x1) Solution with Receive Diversity

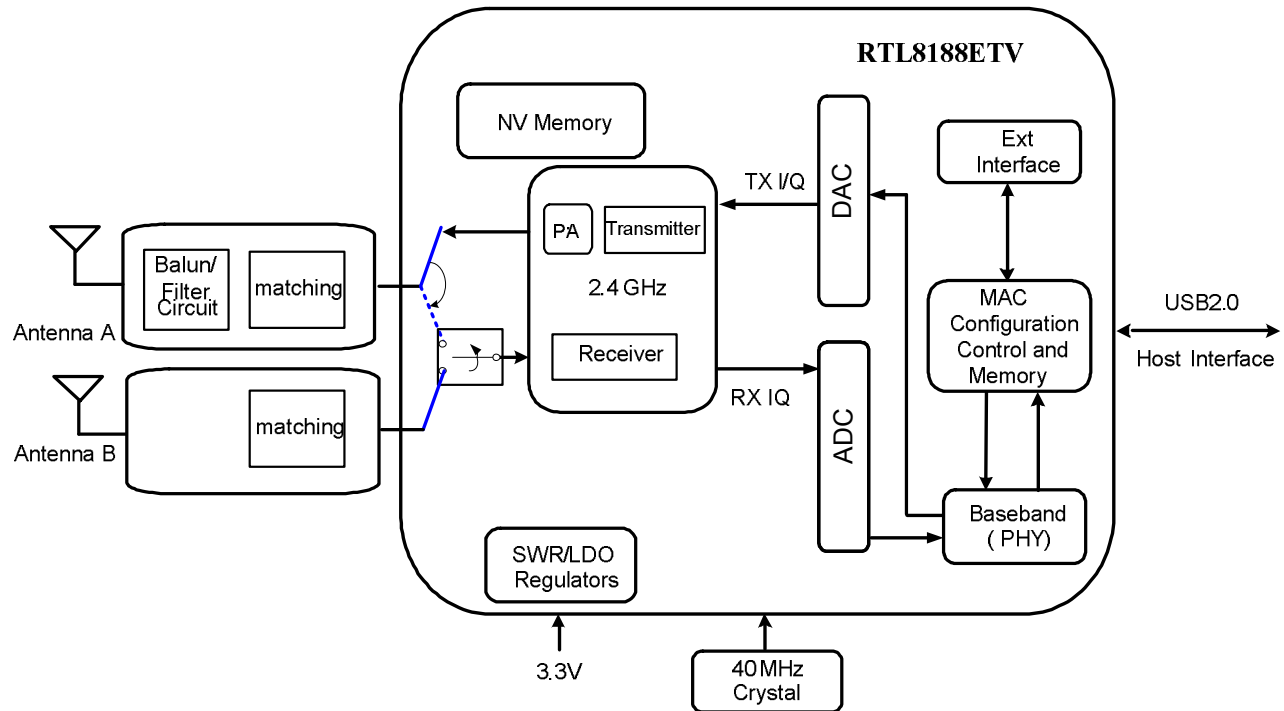
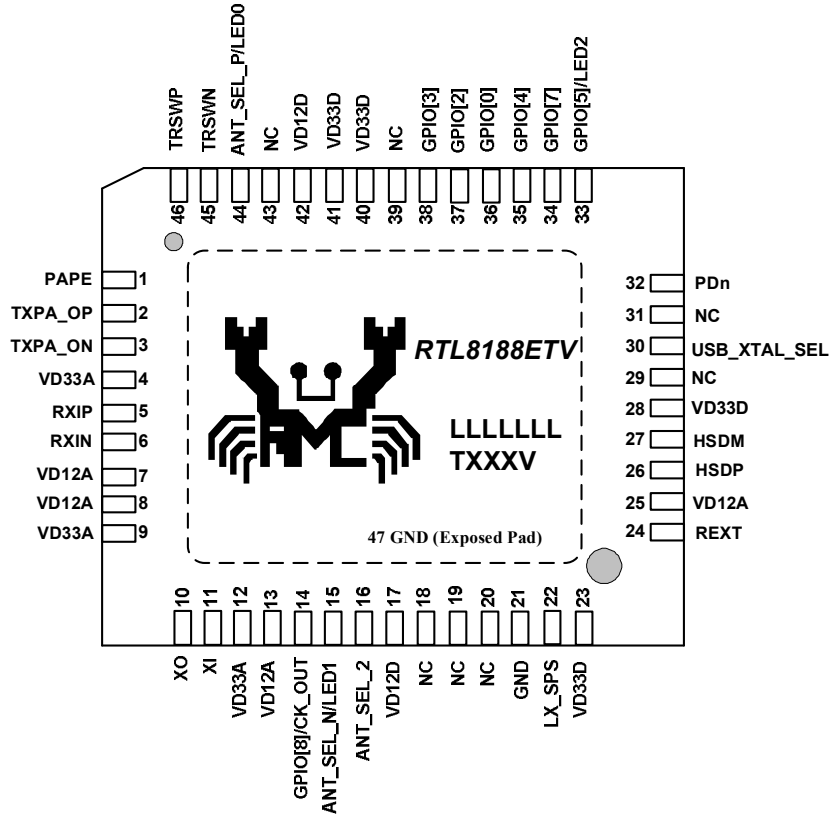

Figure 3. Single-Band 11n (1x1) Transmit & Receive Diversity sSolution

4. Pin Assignments

Figure 4. Pin Assignments

4.1. Package Identification

'Green' package is indicated by a 'G' in the location marked 'T' in Figure 4.

5. Pin Descriptions

The following signal type codes are used in the tables:

I: Input

O: Output

T/S: Tri-State bi-directional input/output pin S/T/S: Sustained Tri-State

O/D: Open Drain

P: Power pin

5.1. USB Bus Transceiver Interface

Table 1. USB bus Transceiver Interface

Symbol	Type	Pin No	Description
HSDM/HSDP	I	27/26	USB Receive Differential Pair

5.2. Power Pins

Table 2. Power Pins

Symbol	Type	Pin No	Description
LX_SPS	P	22	Switching Regulator Output
VD33A	P	4,9,12,	VDD 3.3V for Analog
VD33D	P	23,28,40,41	VDD 3.3V for Digital
VD12A	P	7,8,13,25	Analog 1.2V Regulator Output
VD12D	P	17,42	Digital 1.2V Regulator Output
GND	P	21,47	Ground

5.3. RF Interface

Table 3. RF Interface

Symbol	Type	Pin No	Description
TRSWN	O	45	Transmit/Receive Shared with LED2, can be selected by control register
PAPE	O	1	2.4GHz Transmit Power Amplifier Power Enable 0
TRSWP	O	46	Transmit/Receive
TXPA_OP	O	2	RF TX Negative Signal
TXPA_ON	O	3	RF TX Positive Signal
RX_IP	I	5	RF RX Positive Signal
RX_IN	I	6	RF RX Negative Signal
ANT_SEL_P	O	44	Antenna Control Positive Signal Shared with LED0, can be selected by control register
ANT_SEL_N	O	15	Antenna Control Negative Signal Shared with LED1, can be selected by control register
ANT_SEL_2	O	16	Antenna Control Extend Signal

5.4. LED Interface

Table 4. LED Interface

Symbol	Type	Pin No	Description
LED0	O	44	LED Pins (Active Low) Shared with ANT_SEL_P, can be selected by control register
LED1	O	15	LED Pins (Active Low) Shared with ANT_SEL_N, can be selected by control register
LED2	O	33	LED Pins (Active Low) Shared with GPIO5, can be selected by control register

5.5. Clock and Other Pins

Table 5. Clock and Other Pins

Symbol	Type	Pin No	Description
XI	I	11	25/40MHz OSC Input Input of 25/40MHz Crystal clock reference
XO	O	10	Output of 25/40MHz Crystal Clock Reference
PDn	I	32	This Pin can Externally Shutdown RTL8188CE without Extra Power Switch
REXT	O	24	Band gap. It needs to link 24k resistor pull down.
USB_XTAL_SEL	I	30	Trap Function: Decide to use the 25/40Mhz crystal by this pin power on latch low or high. USB_XTAL_SEL = 1, XTAL frequency is 40MHz USB_XTAL_SEL = 0, XTAL frequency is 25MHz
GPIO0/WLAN_ACT	IO	36	General Purpose Input/Output Pin or Bluetooth Coexistence WLAN_ACT Pin The WLAN_ACT signal indicates when WLAN is either transmitting or receiving in the 2.4GHz ISM band.
GPIO2/BT_STATE	IO	37	General Purpose Input/Output Pin or Bluetooth Coexistence BT_STAT Pin The BTSTAT signal indicates when normal Bluetooth packets are being transmitted or received.
GPIO3/BT_PRI	IO	38	General Purpose Input/Output Pin or Bluetooth Coexistence BT_PRI Pin The BTPRI signal indicates when a high priority Bluetooth packet is being transmitted or received.
GPIO4	IO	35	General Purpose Input/Output Pin
GPIO5/LED2	IO	33	General Purpose Input/Output Pin Shared with LED2, can be selected by control register
GPIO7	IO	34	This pin can also support WLAN Radio off function with host interface remaining connected.
GPIO8/CK_OUT	IO	14	General Purpose Input/Output Pin Buffered 25/40M clock outputs for other peripheral IC
NC	NA	18,19,20, 29,31, 39, 43	No connect. Let it open.

6. Electrical and Thermal Characteristics

6.1. Temperature Limit Ratings

Table 6. Temperature Limit Ratings

Parameter	Minimum	Maximum	Units
Storage Temperature	-55	+125	°C
Ambient Operating Temperature	0	70	°C
Junction Temperature	0	125	°C

6.2. DC Characteristics

6.2.1. Power Supply Characteristics

Table 7. DC Characteristics

Symbol	Parameter	Minimum	Typical	Maximum	Units
VD33A, VD33D	3.3V I/O Supply Voltage	3.0	3.3	3.6	V
VD12A, VD12D	1.2V Core Supply Voltage	1.10	1.2	1.32	V
VD15A, VD15D	1.5V Supply Voltage	1.425	1.5	1.575	V
IDD33	3.3V Rating Current	-	-	600	mA

6.2.2. Digital IO Pin DC Characteristics

Table 8. 3.3V GPIO DC Characteristics

Symbol	Parameter	Minimum	Normal	Maximum	Units
V _{IH}	Input high voltage	2.0	3.3	3.6	V
V _{IL}	Input low voltage	--	0	0.9	V
V _{OH}	Output high voltage	2.97	--	3.3	V
V _{OL}	Output low voltage	0	--	0.33	V

Table 9. 2.8V GPIO DC Characteristics

Symbol	Parameter	Minimum	Normal	Maximum	Units
V _{IH}	Input high voltage	1.8	2.8	3.1	V
V _{IL}	Input low voltage	--	0	0.8	V
V _{OH}	Output high voltage	2.5	--	3.1	V
V _{OL}	Output low voltage	0	--	0.28	V

Table 10. 1.8V GPIO DC Characteristics

Symbol	Parameter	Minimum	Normal	Maximum	Units
V_{IH}	Input high voltage	1.7	1.8	2.0	V
V_{IL}	Input low voltage	--	0	0.8	V
V_{OH}	Output high voltage	1.62	--	1.8	V
V_{OL}	Output low voltage	0	--	0.18	V

7. Interface Timing Specification

7.1. USB Bus during Power On Sequence

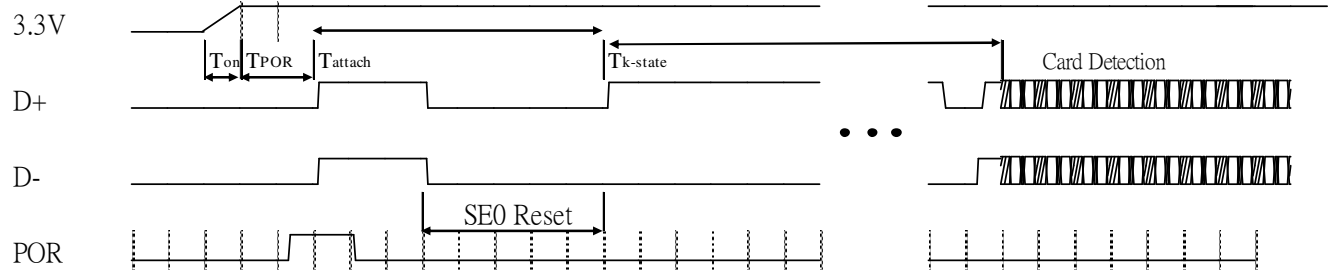

Figure 5. RTL8188ETV USB Bus Power On Sequence

T_{on}: The main power ramp up duration

T_{por}: The power on reset releases and power management unit executes power on tasks

T_{attach}: USB attach state

T_{k-state}: the duration from resistor attached to USB host starting card detection procedure

The power on flow description:

After main 3.3V ramp up, the internal power on reset is released by power ready detection circuit and the power management unit will be enabled. The power management unit enables the internal regulator and clock circuits.

The power management unit also enables the USB circuits.

USB analog circuits attach resistors to indicate the insertion of the USB device

Table 11. The typical timing range

	Unit	Min	Typical	Max
T_{on}	ms	--	1.5	5
T_{por}	ms	--	2	10
T_{attach}	ms	2	7	15
T_{k-state}	ms	50	250	--

8. Mechanical Dimensions

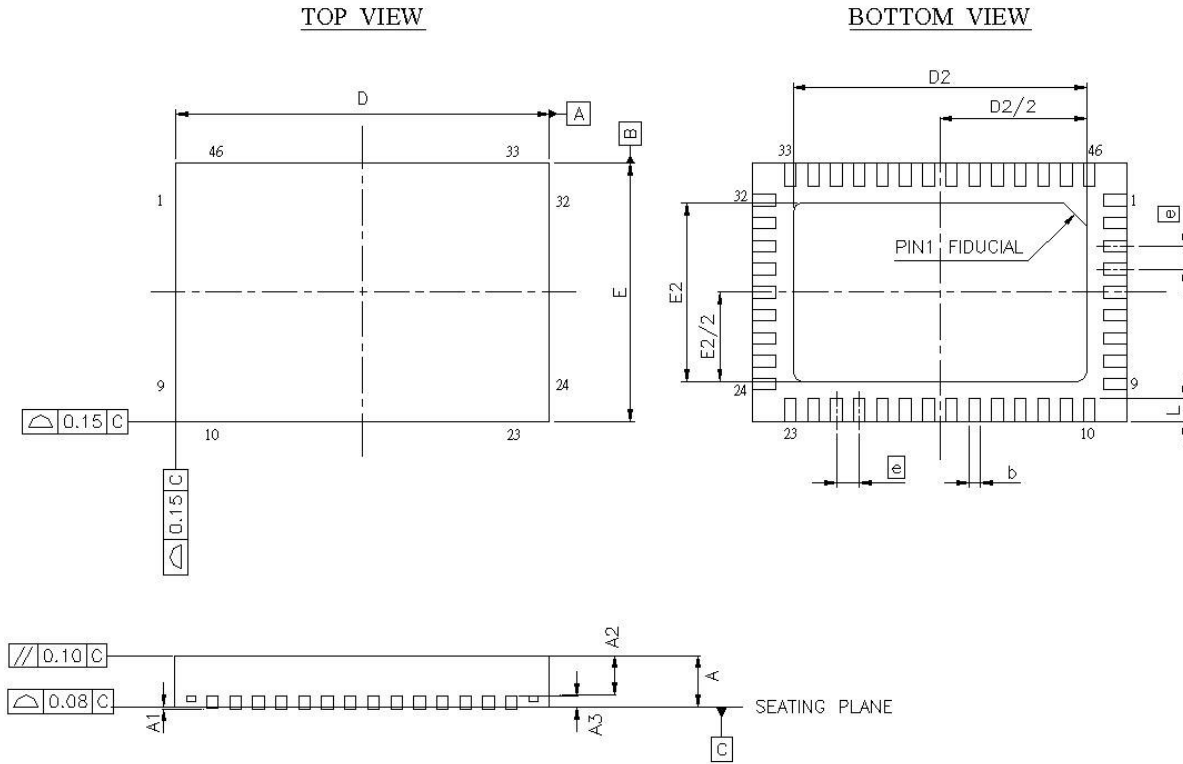

8.1. Mechanical Dimensions Notes

Symbol	Dimension in mm			Dimension in inch		
	Min	Nom	Max	Min	Nom	Max
A	0.75	0.85	1.00	0.030	0.034	0.039
A ₁	0.00	0.035	0.05	0.000	0.001	0.002
A ₂	0.55	0.65	0.80	0.022	0.026	0.032
A ₃	0.20 REF			0.008 REF		
b	0.15	0.20	0.25	0.006	0.008	0.010
D	6.50BSC			0.256BSC		
D2	4.85	5.1	5.35	0.191	0.201	0.211
E	4.5BSC			0.177BSC		
E2	2.25	2.5	2.75	0.088	0.098	0.108
e	0.40BSC			0.016BSC		
L	0.30	0.40	0.50	0.012	0.016	0.020

Notes :

1. CONTROLLING DIMENSION : MILLIMETER(mm).
2. REFERENCE DOCUMENTL : JEDEC MO-220.

9. Ordering Information

Table 12. Ordering Information

Part Number	Package	Status
RTL8188ETV-CG	QFN-46, 'Green' Package	Engineering Samples

Note: See page 7 for package identification.

Realtek Semiconductor Corp.**Headquarters**

No. 2, Innovation Road II, Hsinchu Science Park,
Hsinchu 300, Taiwan, R.O.C.

Tel: 886-3-5780211 Fax: 886-3-5776047

www.realtek.com