



user manual
manual de usuario

EN

ES

RCS13101E



Read these instructions before using your new product for the first time.
Es importante leer este manual antes de usar por vez primera su equipo.

Safety Instructions



* SEE REAR OF UNIT FOR GRAPHIC SYMBOLS *

The lightning flash with an arrowhead symbol, within the equilateral triangle, is intended to alert the user to the presence of uninsulated "dangerous voltage" within the product's enclosure that may be of sufficient magnitude to cause an electric shock.



The exclamation point within the equilateral triangle is intended to alert the user to the presence of important operating and maintenance (servicing) instructions in this owner's manual.



WARNINGS:

- TO PREVENT FIRE OR SHOCK HAZARD, DO NOT EXPOSE THE UNIT TO RAIN OR MOISTURE.
- TO AVOID ELECTRICAL SHOCK, DO NOT OPEN THE CABINET. REFER SERVICING TO QUALIFIED PERSONNEL ONLY.
- THE APPARATUS SHALL NOT BE EXPOSED TO DRIPPING OR SPLASHING AND THAT NO OBJECTS FILLED WITH LIQUID, SUCH AS VASES, SHALL BE PLACED ON THE APPARATUS.

CAN ICES-3 (B)/ NMB-3(B)



This product contains a low power laser device.



Double insulation when servicing use only identical replacement parts.



Equipment tested for compliance as a complete unit

FCC Statements

NOTE: This equipment has been tested and found to comply with the limits for a Class B digital device, pursuant to Part 15 of the FCC Rules. These limits are designed to provide reasonable protection against harmful interference in a residential installation. This equipment generates, uses and can radiate radio frequency energy and, if not installed and used in accordance with the instructions, may cause harmful interference to radio communications. However, there is no guarantee that interference will not occur in a particular installation. If this equipment does cause harmful interference to radio or television reception, which can be determined by turning the equipment off and on, the user is encouraged to try to correct the interference by one or more of the following measures:

- Reorient or relocate the receiving antenna.
- Increase the separation between the equipment and receiver.
- Connect the equipment into an outlet on a circuit different from that to which the receiver is connected.
- Consult the dealer or an experienced radio/TV technician for help.

WARNING:

Changes or modifications to this unit not expressly approved by the party responsible for compliance could void the user's authority to operate the equipment.

FCC RF Radiation Exposure Statement

Caution: To maintain compliance with the FCC's RF exposure guidelines, place the Internet Music System at least 20cm from nearby persons.

Service Information

This product should be serviced only by those specially trained in appropriate servicing techniques. For instructions on how to obtain service, refer to the warranty included in this guide.

Warnings:

- The AC power plug is used as disconnect device and it should remain readily operable during intended use. In order to disconnect the apparatus from the mains completely, the AC power plug should be disconnected from the mains socket outlet completely.
- The mains plug of apparatus should not be obstructed OR should be easily accessed during intended use.
- Minimum 10 cm (4 inches) distances around the apparatus for sufficient ventilations.
- The ventilation should not be impeded by covering the ventilation openings with items such as newspaper, table-cloths, curtains, etc.
- No naked flame sources such as lighted candles should be placed on the apparatus.

On Safety

As the laser beam used in this compact disc player could be harmful to the eyes, do not attempt to disassemble the casing. Refer servicing to qualified personnel only.

- Do not put any foreign objects in the disc compartment. If you do so, the laser beam interlock may be defeated allowing the laser to remain on when the lid is opened.
- Should any objects or liquids fall into the unit, disconnect the power supply and have the unit checked by qualified personnel before any further operation.

On Operation

Since the CD system offers a wide dynamic range, the peaks of the high level inputs are recorded with high fidelity, and the noise level is very low. Do not turn up the volume while listening to a part of the disc with no audio signals or very low level inputs. If you do so, the speakers may be damaged when the peak level of the sound is played. The lens of the laser should be kept clean. Do not touch the lens. If you do so, the lens may be damaged and the unit will not operate correctly.

On Use

Never use the unit where it would be subject to:

- Heat sources such as radiators or air ducts.
- Direct sunlight.
- Excessive dust.
- Moisture or rain.
- Mechanical vibration or shock.
- Uneven surface.
- Do not place any heavy objects on top of the unit.
- When the unit is used with an AC power plug, do not wrap the unit in a cloth, blanket, etc. If you do so, the temperature inside and outside the unit may rise considerably, resulting in malfunctioning of the unit.
- If the unit is brought directly from a cold to a warm location, or is placed in a very damp room, the moisture may condense on the lens inside the unit. Should this occur, the unit will not operate. In this case, remove the disc and leave the unit in a warm place for several hours until the moisture evaporates.
- For the unit to operate at its best, it should not be subject to temperatures below 41°F (5°C) or above 95°F (35°C).

Additional safety information

- Apparatus shall not be exposed to dripping or splashing and no objects filled with liquids, such as vases, shall be placed on the apparatus.
- Always leave sufficient space around the product for ventilation. Do not place product in or on a bed, rug, in a bookcase or cabinet that may prevent air flow through vent openings.
- Do not place lighted candles, cigarettes, cigars, etc. on the product.
- Connect power plug only to AC power source as marked on the product.
- Care should be taken so that objects do not fall into the product.
- Do not attempt to disassemble the cabinet. This product does not contain customer serviceable components.

Safety Instructions

Precautions

- This compact disc player uses a laser to read the music on the disc. The laser mechanism corresponds to the cartridge and stylus of a record player. Although this product incorporates a laser pick-up lens, it is completely safe when operated according to directions.
- Discs rotate at high speed inside the player. Do not use damaged, warped, or cracked discs.
- Do not touch the pick-up lens which is located inside the disc compartment. To keep dust from collecting on the pick-up lens, do not leave the compartment door open for an extended period of time. If the lens becomes dirty, clean it with a soft brush, or use an air blower brush designed for camera lenses.

Headset safety

- Have a Blast-Just Not in your eardrums! Make sure you turn down the volume on the unit before you put on headphones. Increase the volume to the desired level only after headphone are in place.
- Do not play your headset at high volume. Hearing experts warn against extended high-volume play.
- If you experience ringing in your ears, reduce volume or discontinue use.
- You should use with extreme caution or temporarily discontinue use in potentially hazardous situations. Even if your headset is an open-air designed to let you to hear outside sounds, do not turn up the volume so high that you are unable to hear what is around you.
- Excessive sound pressure from earphones and headphone can cause hearing loss.

System connections

Connect the speakers to the R (R+, R-) terminals and the L (L+, L-) terminals.

Note:

Connecting speakers other than the speakers supplied with the unit may damage the unit.

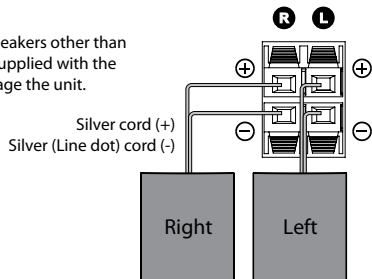

CAUTIONS:

- Ensure that the power supply in your house complies with that indicated on the identification sticker located on the back of your unit (AC 120V ~ 60Hz).
- If you are not going to use the unit for a long time, disconnect the AC power plug from the wall outlet.
- This unit is designed for continuous use. Switching off the unit to standby mode does not disconnect it from the power supply. To completely isolate the equipment, remove the plug from the power outlet as some components remain connected to the electrical supply.

Remote Control

Using the Remote Control

- Point the remote control at the REMOTE SENSOR located on the unit.
- When using this unit in very bright light, the infrared REMOTE SENSOR may not work properly.

To Change Remote Battery

1. Open the battery door.
2. Insert 2 AAA size batteries.

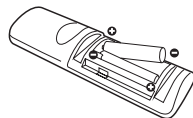
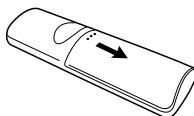

Battery Replacement

When the battery becomes weak, the operating distance of the remote control will be greatly reduced and you will need to replace the battery.

Note:

If the remote control is not going to be used for a long time, remove the battery.

WARNING:

- Do not dispose of the battery in a fire or it may leak and/or explode.
- Batteries should not be exposed to excessive heat such as sunshine, fire or the like.

CAUTION:

Danger of explosion if battery is incorrectly replaced. Replace only with the same or equivalent type.

IMPORTANT SAFETY INSTRUCTIONS

1. Read these instructions.
2. Keep these instructions.
3. Heed all warnings.
4. Follow all instructions.
5. Do not use this apparatus near water.
6. Clean only with a dry cloth.
7. Do not block the ventilation openings. Install in accordance with the manufacturer's instructions.
8. Do not install near any heat sources such as radiators, heat registers, stoves, or other apparatus (including amplifiers) that produce heat.
9. Do not defeat the safety purpose of a polarized or grounding-type plug. A polarized plug has two blades with one wider than the other. A grounding type plug has two blades and a third grounding prong. The wide blade or the third prong are provided for your safety. If the provided plug does not fit into your outlet, consult an electrician for replacement of the obsolete outlet.
10. Protect the power cord from being walked on or pinched particularly at plugs, convenience receptacles, and the point where they exit from the apparatus.
11. Only use attachments/accessories specified by the manufacturer.
12. Use only with a cart, stand, tripod, bracket, or table specified by the manufacturer, or sold with the apparatus. When a cart is used, use caution when moving the cart/apparatus combination to avoid injury from tip-over.
13. Unplug this apparatus during lightning storms or when unused for long periods of time.
14. Refer all servicing to qualified service personnel. Servicing is required when the apparatus has been damaged in any way, such as the AC power cord or plug is damaged, liquid has spilled or objects have fallen into the apparatus, the apparatus has been exposed to rain or moisture, does not operate normally, or has been dropped.



Portable Cart Warning

Control Reference Guide

Remote Control

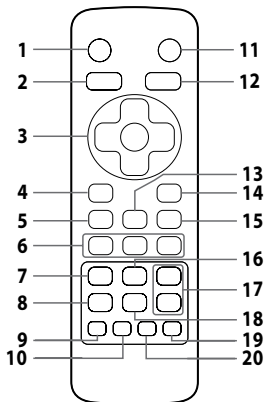

1. **STANDBY** button
Press to standby the unit.
Press and hold to shut down the unit.
2. **↻ (RETURN)** button
3. **Cursor (<, >, ^, v)** buttons
Move between selections on a menu screen and adjust certain settings.
OK button
Confirm selections on a menu screen.
4. **INTERNET** button
Press to return to Internet mode.
5. **CD** button
Press to return to CD mode.
6. **⏮ PREV** button
Move back through tracks on the disc.
Press to tune the FM frequency.
⏸ PLAY / PAUSE button
Start or resume playback of a disc.
Press once to pause playback. Press subsequently to advance frame by frame on a CD.
⏭ NEXT button
Skip to next track on a disc.
Press to tune the FM frequency.
7. **GALLERY** button
Press to return to Gallery folder.
8. **PLAY MUSIC** button
Press to select the Play Music mode.
9. **REPEAT** button
Press to repeat the desired songs when playing CD.
10. **RANDOM** button
Press to random playing CD.
11. **🔇 MUTE** button
12. **🏠 (Home screen)** button
Press to return to home screen page.
13. **📶 Bluetooth** button
Press to select the Bluetooth mode.
14. **LINE IN** button
Press to select the Line In mode.
15. **FM** button
Press to return to FM mode.
16. **■ STOP** button
Stop playing a disc.
17. **VOL + / -** buttons
Adjust the volume level.
18. **SCREEN** button
Press to switch screen on/off.
19. **MEMORY** button
Press to memory the radio station.
20. **EQ** button
Press to select the desired music mode (POP / CLASSIC / FLAT / JAZZ).

Unit

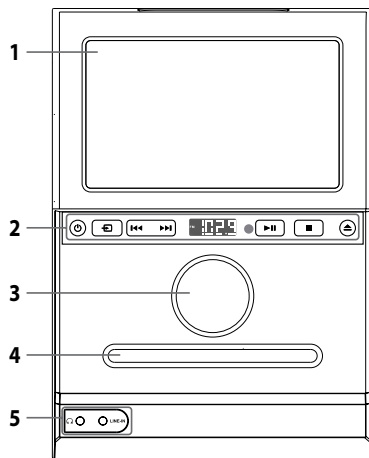

1. **Screen**
Micro SD Card Slot
Support up to 32G (Micro SD card not included)
Micro HDMI jack
Micro USB jack
2. **⏻ STANDBY/ON** button
Press and hold to shut down the control panel.
Function button
⏮ button
⏭ button
Display
Remote Sensor
⏸ button
■ button
▲ button
3. **Master Volume knob**
4. **CD Door**
5. **Headphone jack**
LINE IN jack

Accessories

Please check and identify the supplied accessories.

- | | |
|--|-----|
| <input type="checkbox"/> Remote Control with 2 "AAA" batteries | X 1 |
| <input type="checkbox"/> HDMI converter cable | X 1 |
| <input type="checkbox"/> USB converter cable | X 1 |

First Time Operation

Turning Your Unit On for the First Time

When using the unit for the first time, you will be required to setup the following:

1. Select the language, then tap Start.
2. Select the Wi-Fi.
3. If you have a Google account, select "Yes". Then tap a network name to see more details or connect to it, and enter a password if necessary.
When prompted, sign in using the email address and password for your Google Account. If you don't have one yet, go ahead and create one.
4. Follow the onscreen instructions to setup the unit.

Basic Operation

Using the Touchscreen

Here are some basic procedures for interacting with the touchscreen.



Tap
To select an item on the touchscreen, lightly tap it.



Press & Hold
In some instances, touching the item and holding your finger on it will present other options or menus.

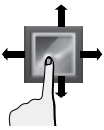

Drag or Swipe
While holding an item such as an icon, it can sometimes be moved by dragging it to another area or screen. You may also be able to swipe your finger across a screen or item to navigate or move it.

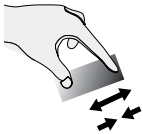

Zoom
By placing two fingers on the screen, you can slide them apart to "Zoom In", or pinch them together to "Zoom Out".

Download apps on Google Play™

In addition to the apps that are preloaded on the system, you can choose from hundreds of thousands of apps from the Google Play store. Simply tap on the Play Store icon to find and download the apps you want.

Customizing the Home Screen

- **Moving Apps to the Home screen:** Tap All Apps button to open All Apps screen, press & hold an icon or widget and slowly to drag it to the location of your choice.
- **Move apps or widgets:** Press & hold an icon or widget, slowly to drag it to the screen edge, the screen will switch and you can release the app on the screen of your choice.
- **Grouping apps:** Press & hold an app icon and drag it on top of another app. This will create a folder for these apps which can be renamed by tapping on the folder once and then tapping the folder's name. Additional apps can be dropped into the folder.
- **Delete apps or widgets from the Home screen:** Press & hold an icon or widget, when the "X" icon appears at the left of the screen, drag the icon or widget into it. This will remove the app or widget from the Home screen. However, the app won't be deleted from the system. It can still be found in the All Apps button.
- **Modify your Wallpaper:** Press & hold an empty space on your Home screen, and choose your wallpaper from Gallery, Live Wallpapers or Wallpapers.

Voice Search & Voice Actions

Turn Voice Search or Voice Action On

You can initiate a Voice Search or Voice Action by tapping the Microphone icon in the top right corner of the Home screen.

When you're viewing the Google Now screen, you don't have to touch anything. Just say "Google."

Note:

To detect when you say "Google" to launch Voice Search or Voice Actions, Google analyzes sound picked up by your unit's microphone in intervals of a few seconds or less. The sound is immediately discarded after analysis and is not stored on the device or sent to Google servers.

Using Voice Search

After tapping the microphone icon, just say whatever it is you want Google to search for.

Using Voice Actions

There are many actions that the unit can perform using "Voice Actions". For example, you can send emails, set alarms, play a song, or navigate to a website. Just tap the Microphone icon, and say what you want the unit to do. As you speak, Voice Search analyzes your speech and initiates the action.

If Voice Search doesn't understand you, it lists a set of possible meanings. Just tap the one you want.

Navigating the Home Screen

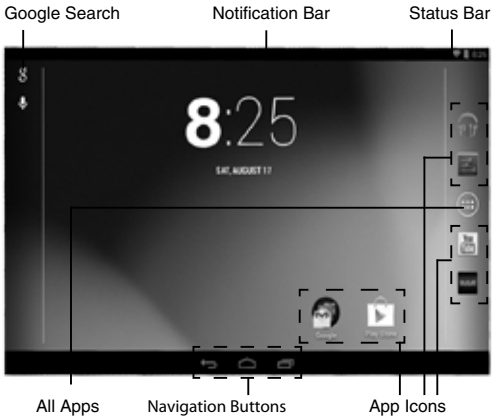

Notification & Status Bar

Some indicators that inform you about the status of your unit are shown at the top of the screen.

Notification Shade

Notifications may come from the system, a game, an application such as E-mail, or the music player.

When Notifications are available, related icons will appear in the top left corner of the screen. To open the Notification Shade, touch the Notification icon and swipe your finger down. Some notifications allow you to take specific actions by tapping icons within the notification.

After you are finished with a notification, just slide it away to the left or right. If you want to dismiss all notifications, tap the Dismiss icon at the top of the notification.

Status Bar & Quick Settings

The Status Bar in the top right corner shows various indicators, including Wi-Fi connection and battery status. To access "Quick Settings", touch the status bar and swipe down. You can then adjust various settings on the tablet by touching the corresponding square.

Notification & Status Icons

The below table lists are some of the frequently used icons in the Notification & Status bar:

Item	Description
	Message Received new message.
	Music Play Music application is running.
	Screenshots Screenshot captured.
	USB tethering Has connected to a PC and the USB tethering is turned on.
	Wi-Fi Has a Wi-Fi Internet connection.
	Play Store An update for an app is available.

Home Screen Icons

All Apps

Tap the All Apps icon to enter the All Apps screen.

In All Apps screen, you can:

- Move between screens: Slide left or right.
- Open an App: Tap its icon.
- Copy an App icon to the Home screen: Press & hold the icon or widget icon and slowly to drag it to the Home screen.
- View widgets: Tap the widgets tab at the top of a All Apps screen. Widgets are app information displays that can be placed on your Home screen.
- Get more apps: Tap the **Google Play Store** icon , or the Shop icon at the upper right corner.
- View info about an App: Press & hold it, and drag it to the top of the screen, then drop the app over the App Info icon .

Tip: Most apps include a Menu icon near the top or bottom of the screen that lets you control the app's settings.

Back

Tap Back icon to return to the previous screen.

- The Back icon remains on the bottom of the screen at all times, allowing you to navigate back to the previous screen.
- Once you go back to the Home screen, you can't go back any further in your history.

Home

Tap Home icon from anywhere on your unit to return to the Home screen.

Recent Apps

Tap Recent Apps icon to view recently used apps. Tap an app to use it again.

You can slide down to see more apps. You can also slide it away to the left or right.

Insert a Micro SD card

Insert a Micro SD card

To increase the memory storage capacity, remove the rubber cover on the side of screen and insert a Micro SD card (not included) into the unit's Micro SD slot until it clicks.

To remove a Micro SD card, push in on the edge of the card until it pops out of the card slot.

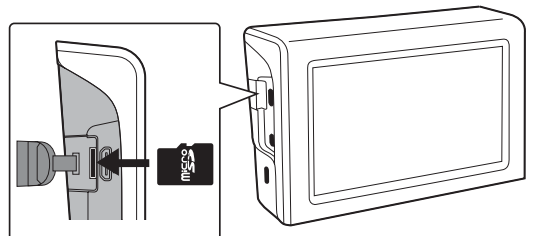

Micro-USB

Connect your unit to a PC or a USB storage device with a USB cable (not included) and USB converter cable (included) to transfer music, pictures and other files in both directions.

Notes:

- To change your unit's USB connection options, you should go to **Settings > DEVICE > Storage**, and tap **Menu icon** at the upper right corner. Then tap **USB computer connection** to enter to setup.
- The unit can be connected to a keyboard, a mouse or other input devices via a USB cable and use it just as you would connect with a PC.

Micro SD

Remove the rubber cover on the side of screen and insert the micro SD card into the unit's Micro SD slot until it clicks.

To check the storage of the micro SD card, go to

Settings > DEVICE > Storage

Remove the micro SD card by pushing in on the card's edge. The card will pop out and can be removed.

Notes:

- You can use microSD™ card and microSDHC™ card (up to 32GB, SD card not included).
- Never remove or insert micro SD card in On mode.

Micro-HDMI

Connect your unit to a TV or other display device with a HDMI cable (not included) and HDMI converter cable (included) to output the video.

Notes:

- To change your unit's HDMI options, you should go to **Settings > HDMI >** to modify each setting.

HDMI™ HDMI, the HDMI logo and High-Definition Multimedia Interface are trademarks or registered trademarks of HDMI Licensing, LLC.

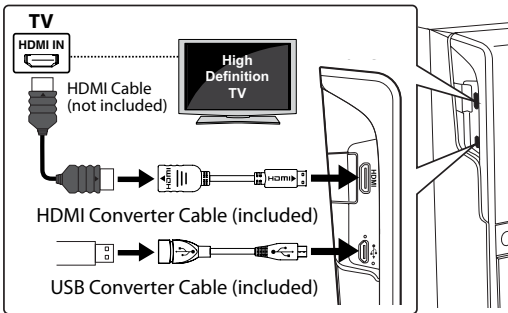

Wi-Fi

Connect to a Wi-Fi Network

- Go to **Settings > WIRELESS & NETWORKS > Wi-Fi**, and slide the Wi-Fi switch to the ON position.
- The device will scan Wi-Fi networks automatically and display the available names.
- If the device finds a network that you connected to previously, it will connect to it automatically.
- Tap a network name to connect to it, and enter a password if necessary.
- Alternatively, if your Wi-Fi router supports Wi-Fi Protected Setup, tap the WPS icon at the top of the screen, and then press the WPS button on your router.
- If your network does not broadcast its SSID, tap the Plus icon + at the top of the screen, and enter the Network SSID (name) of the network. If necessary, enter security or other network configuration details.

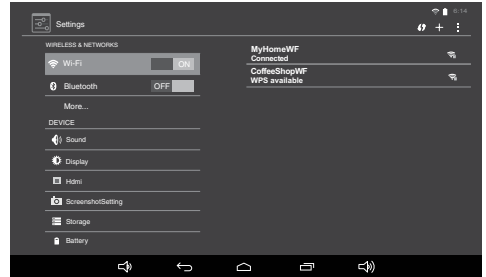

Note:

you can tap **Menu icon** at the upper right corner in the **Settings** screen for advanced settings.

VPN (Virtual Private Network)

You can create virtual private network (VPN) and connect to your private network securely through a public network, such as the internet. You must set a lock screen PIN or password before you can use credential storage.

Add VPN network and follow the instructions on the screen.

Volume Adjustment

To Adjust the Volume

The volume can be adjusted using the Master Volume Knob on the main unit, or the Volume Up/Down Buttons on the remote control.

For Personal Listening

Connect headphones (Ø3.5mm stereo mini plug) to the earphone jack. Adjust the VOLUME levels to obtain the desired volume.

When headphones are connected, the speakers are automatically muted.

Warning: Excessive sound pressure from earphones and headphones can cause hearing loss.

Preset EQ

This system supports a variety of equalizers and sound effects. During playback, press the **EQ** button to select a desired music mode. Each time the **EQ** button is pressed, the music mode will be changed to the next one as follows:

POP / CLASSIC / FLAT / JAZZ

Line-In Playback

You can connect audio devices such as your iPod, CD players or MP3 players to the unit via the LINE IN jack. To do this, connect an audio cable from the line out or headphone out jack of the other audio device to the LINE IN jack on the unit's front panel.

Listening to the Connected Device

1. Press the **LINE IN** button to LINE IN mode and "L-in" is shown on the display.
2. Turn on the audio device you've attached to the LINE IN jack.

Listen to the Radio

1. Press the **POWER** button to turn the unit on.
2. Press the **FM** button to FM mode.
3. Press the **PREV** or **NEXT** button to tune in to a station.
4. Adjust the volume levels.

Searching for a Station Automatically

- Press and hold the **PREV** or **NEXT** button until the tuner starts searching for a station, then release. After tuning in a station, the search stops.
- The search may not stop at a station with a very weak signal.

Presetting Stations

The unit can store a total of 20 stations in memory. Presetting allows you to tune in to a station directly.

1. Tune in to a desired station.
2. Press and hold the **MEMORY** button. The preset number will blink and the "PXX" indicator will be shown on the display.
3. Press the **PREV** or **NEXT** button to select the preset number.
4. Press the **MEMORY** button again to store it in memory.
5. Repeat steps 1-4 to store other stations.

Tuning into a Preset Station

Press **PLAY/PAUSE** button on the unit or press **▲** or **▼** button on the remote control to select a preset number.

For Better reception

FM: Fully unwind the antenna wire. Extend the antenna wire and place it in the position that sounds best.

Note: Do not connect the FM antenna to an outside antenna.

Connect a Bluetooth® device to the Main Unit

The system can wirelessly receive and playback audio from a Bluetooth-equipped smartphone, tablet, or computer.

1. Go to **Settings > WIRELESS & NETWORKS > BLUETOOTH**, and slide the Bluetooth® switch to the ON position.
2. Turn on the Bluetooth® device you wish to pair and connect.
3. On your Bluetooth® enabled device, search for the "RCA RCS13101E" in the list of discovered devices and select it.

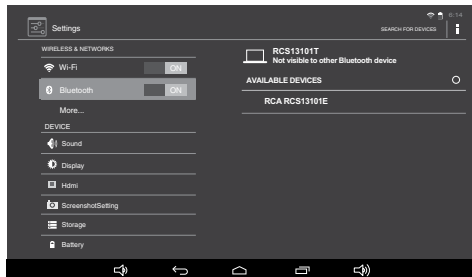

Note: If your Bluetooth® device (e.g. Smart phone etc.) need the PIN code while pairing, please enter 4-digit number: 0000.

 **Bluetooth**® The Bluetooth® word mark and logos are registered trademarks owned by Bluetooth SIG, Inc.

CD Playback

1. Press the **POWER** button to turn on the unit.
 2. Press the **CD** button to CD mode.
 3. Press the **OPEN** button to open the CD door. Place a disc in the center with the label side up and then press the **OPEN** button again to close the CD door. Then, it plays automatically.
- Adjust the volume levels.

To Pause Playback

- Press the **PAUSE** button.
- To resume playback, press the **PAUSE** button again.

To Stop Playback

- Press the **STOP** button.

Skipping to Another Track

- Press either the **PREV** or **NEXT** button according to the desired direction.
- Press the **PREV** button to skip to the start of the current track or skip to previous tracks. Press the **NEXT** button to skip to the beginning of the next track.

Locating a Particular Point on a Track

- Keep either the **PREV** or **NEXT** button pressed during playback, according to the desired direction, and release at the desired point.

Repeat Playback

Repeat the current track

- Press the **REPEAT** button until “**rP1**” blinks on the display. The current track will be played repeatedly.

Repeat the Entire CD

- Press the **REPEAT** button until “**rPA**” stops blinking and remains on. All tracks will be played repeatedly.

Cancel Playback Mode

- Press the **REPEAT** button to cancel the playing until “**OFF**” appears.

Random Playback

Random Playback

- Press the **RANDOM** button on the remote control and “**rdn**” will be shown on the display. All tracks will be played randomly. After all tracks have played, the unit will stop automatically.

Cancel Random Playback

- Press the **RANDOM** button on the remote control again during **RANDOM** playback to return to normal playback and “**OFF**” will be shown on the display.

Maintenance

Cleaning the Disc

A defective or soiled disc inserted into the unit can cause sound to drop out during playback.

Handle the disc by holding its inner and outer edges.

- Do NOT touch the surface of the unlabeled side of the disc.
- Do NOT stick paper or tape on the surface.
- Do NOT expose the disc to direct sunlight or excessive heat.
- Clean the disc before playback. Wipe the disc from the center outward with a cleaning cloth.
- NEVER use solvents such as benzine or alcohol to clean the disc.
- Do NOT use irregular shaped discs (example: heart shaped, octagonal, etc.). They may cause malfunctions.



Cleaning the Unit

- Be sure to turn the unit off and disconnect the AC power adapter before cleaning the unit.
- Wipe the unit with a dry soft cloth. If the surfaces are extremely dirty, wipe clean with a cloth that has been dipped in a weak soap-and-water solution and wrung out thoroughly, then wipe with a dry cloth.
- Never use alcohol, benzine, thinner, cleaning fluid or other chemicals. Do NOT use compressed air to remove dust.

Important Note

- Before transporting the unit, remove the disc from the disc compartment.

Troubleshooting Guide

No power.

- System does not turn on.
- Make sure AC power plug is secure in the outlet, and outlet has power.

The remote control does not function.

- Make sure the infrared remote sensor is not blocked.
- Point the remote directly at the infrared remote sensor on the unit.
- Replace the battery in the remote control with a new one.

Poor FM reception.

- Make sure FM antenna wire is fully extended.
- Electrical interference in your home can cause poor reception. Move the unit away from them (especially those with motors and transformers).

The CD Disc does not play.

- Make sure you've selected CD mode.
- Make sure disc label is facing up.
- Make sure disc is clean.
- Pause mode is activated.
- Disc may be damaged or dirty; check disc.

Severe hum or noise is heard.

- The plugs and jacks are dirty. Wipe them with a cloth slightly moistened with alcohol.
- Clean the disc.

Limited Warranty

AVC MULTIMEDIA ("AVC") makes the following limited warranty. This limited warranty extend to the original consumer purchaser and is limited to non-commercial use of the product.

One Year Parts & Labor Warranty

AVC products purchased in the United States or Canada are warranted to be free from defects in materials or workmanship for a period of one year from the date of their original retail purchase. If the unit fails to conform to this warranty, we will service the product using new or refurbished parts and products, at **AVC's** sole discretion.

During a period of one year from the effective warranty date, **AVC** will provide, when needed, service labor to repair a manufacturing defect at its designated Service Center. To obtain warranty service in the United States or Canada, you must first call our **Customer Support Center at 1-877-252-6873 or 1-855-475-9646, during the hours listed in the box below.** The determination of service will be made by **AVC** Customer Support. **PLEASE DO NOT RETURN YOUR UNIT TO AVC WITHOUT PRIOR AUTHORIZATION.** New or remanufactured replacements for defective parts or products will be used for repairs by **AVC** at its designated Service Center for one year from the effective warranty date. Such replacement parts or products are warranted for an additional one year from the date of repair or replacement. The Customer will be required to ship the unit to the Service Center indicated at the time Customer Support is contacted to make the necessary repairs. The customer is responsible for all transportation charges to the service facility.

Packaging and Shipping Instruction

When you send the product to the **AVC** service facility you must use the original carton box and packing material or an equivalent as designated by **AVC**.

Your Responsibility

- (1) You must retain the original sale receipt to provide proof of purchase.
- (2) These warranties are effective only if the product is purchased and operated in the United States or Canada.
- (3) Warranties extend only to defects in material or workmanship, and do not extend to any product or parts which have been lost or discarded, or damage to product or parts caused by misuse, accident, improper operation or maintenance, or use in violation of instructions provided with the product, or to product which has been altered or modified without authorization of **AVC**, or to products or parts thereof which have had the serial number removed or changed.

Out of Warranty

In the event your product requires repair after the limited warranty period has expired, please contact our Customer Support Center at **1-877-252-6873 or 1-855-475-9646 or www.RCAtablets.com**

Hours: Monday–Thursday: 9am–7pm, Friday: 9am–5pm, Saturday: 9am–NOON Eastern time.

Important: You are responsible for any transportation, shipping or insurance relative to the return of product to our Product Returns Center.

All warranties implied by state law, including the implied warranties of merchantability and fitness for a particular purpose, are expressly limited to the duration of the limited warranties set forth above. With the exception of any warranties implied by state law as hereby limited, the foregoing warranty is exclusive and in lieu of all other warranties, guarantees, agreements and similar obligations of manufacturer or seller with respect to the repair or replacement of any parts. In no event shall **AVC** be liable for consequential or incidental damages.

No person, agent, distributor, dealer or company is authorized to change, modify or extend the terms of these warranties in any manner whatsoever. The time within action must be commenced to enforce any obligation of **AVC** arising under the warranty or under any statute, or law of the United States or Canada or any state thereof, is hereby limited to one year from the date of purchase. This limitation does not apply to implied warranties arising under state law.

This warranty gives you specific legal rights and you may also have other rights, which may vary, from state to state. Some states do not allow limitation on how long an implied warranty lasts, when an action may be brought, or the exclusion or limitation of incidental or consequential damages, so the above provisions may not apply to you.

For more information on other products and services, please visit our web site at: **www.RCAtablets.com**

Important: Also keep your "Bill of Sale" as proof of purchase.

Model no
 Product name
 Type of set
 Serial no
 Invoice no
 Date purchased
 Dealer name

FOR SUPPORT, SERVICE AND REPAIR, PLEASE VISIT **www.RCAtablets.com**

Specifications and external appearance are subject to change without notice.

© 2013 AVC MULTIMEDIA