



Valued Quality. Delivered.

TEST REPORT

Report Number: 17050205HKG-001

Application
for
Original Grant of 47 CFR Part 15 Certification
RSS-247 Issue 2 Equipment Certification

Tablet

FCC ID: A2HDRP2091

IC: 9903A-DRP2091

This report contains the data of WLAN (WiFi) portion only.

Prepared and Checked by:

Approved by:

Signed On File

Wong Cheuk Ho, Herbert
Lead Engineer

 Digitally signed
by Jess Tang
Location:
Intertek Testing
Services Hong
Kong Ltd.

Tang Kwan Mo, Jess
Lead Engineer
Date: May 24, 2017

- Intertek's standard Terms and Conditions can be obtained at our website: <http://www.intertek.com/terms/>.
- The test report only allows to be revised within the retention period unless further standard or the requirement was noticed.
- This report is for the exclusive use of Intertek's Client and is provided pursuant to the agreement between Intertek and its Client. Intertek's responsibility and liability are limited to the terms and conditions of the agreement. Intertek assumes no liability to any party, other than to the Client in accordance with the agreement, for any loss, expense or damage occasioned by the use of this report. Only the Client is authorized to permit copying or distribution of this report and then only in its entirety. Any use of the Intertek name or one of its marks for the sale or advertisement of the tested material, product or service must first be approved in writing by Intertek. The observations and test results in this report are relevant only to the sample tested. This report by itself does not imply that the material, product, or service is or has ever been under an Intertek certification program.

Intertek Testing Services Hong Kong Ltd.

2/F., Garment Centre, 576 Castle Peak Road, Kowloon, Hong Kong.
Tel: (852) 2173 8888 Fax: (852) 2785 5487 Website: www.hk.intertek-etlsemko.com

INTERTEK TESTING SERVICES

GENERAL INFORMATION

Applicant Name:	Alco Electronics Ltd
Applicant Address:	11/F., Zung Fu Industrial Building, 1067 King's Road, Quarry Bay, Hong Kong.
Contact Person:	Peggy Suen
Tel:	(852) 2562 6121
Fax:	(852) 2597 5201
e-mail:	peggy.suen@alco.com.hk
Manufacturer:	Alco Electronics (Dongguan) Limited
Manufacturer Address:	Gong Ye Xi Road, Houjie Technology Industrial Park, Houjie, Dongguan, Guangdong P.R.C. 523960 China
FCC Specification Standard:	FCC Part 15, 2015 Edition
IC Specification Standard:	RSS-247 Issue 2, February 2017 RSS-Gen Issue 4, November 2014
FCC ID:	A2HDRP2091
IC:	9903A-DRP2091
Brand Name:	VENTURER / RCA
FCC Model(s):	PVP1101 / DRP2091
For IC HVIN:	PVP1101 / DRP2091
For IC PMN:	PVP1101 / DRP2091
Type of EUT:	Digital Transmission System Transmitter
Description of EUT:	Tablet DVD Combo
Serial Number:	N/A
Sample Receipt Date:	May 05, 2017
Date of Test:	May 05, 2017 to May 23, 2017
Report Date:	May 24, 2017
Environmental Conditions:	Temperature: +10 to 40°C Humidity: 10 to 90%

INTERTEK TESTING SERVICES

Table of Contents

1.0 Test Results Summary & Statement of Compliance	5
1.1 Summary of Test Results	5
1.2 Statement of Compliance	5
2.0 General Description	7
2.1 Product Description	7
2.2 Test Methodology	8
2.3 Test Facility	8
3.0 System Test Configuration	10
3.1 Justification	10
3.2 EUT Exercising Software	12
3.3 Details of EUT and Description of Accessories	12
3.4 Measurement Uncertainty	12
4.0 Test Results	14
4.1 Maximum Conducted Output Power at Antenna Terminals	14
4.2 Minimum 6dB RF Bandwidth	16
4.3 Maximum Power Spectral Density	26
4.4 Out of Band Conducted Emissions / Bandedge	35
4.5 Field Strength Calculation	52
4.6 Transmitter Radiated Emissions in Restricted Bands and Spurious Emissions ..	53
4.6.1 Radiated Emission Configuration Photograph	53
4.6.2 Radiated Emission Data	53
4.6.3 Transmitter Duty Cycle Calculation	68
4.7 AC Power Line Conducted Emission	68
5.0 Equipment List	72

INTERTEK TESTING SERVICES

**EXHIBIT 1
TEST RESULTS SUMMARY & STATEMENT OF COMPLIANCE**

INTERTEK TESTING SERVICES

1.0 Test Results Summary & Statement of Compliance

1.1 Summary of Test Results

Test Items	FCC Part 15 Section	RSS-247/ RSS-Gen# Section	Results	Details see section
Antenna Requirement	15.203	8.3#	Pass	2.1
Max. Conducted Output Power	15.247(b)(3)&(4)	5.4(d)	Pass	4.1
Min. 6dB RF Bandwidth	15.247(a)(2)	5.2(a)	Pass	4.2
Max. Power Density	15.247(e)	5.2(b)	Pass	4.3
Out of Band Antenna Conducted Emission	15.247(d)	5.5	Pass	4.4
Radiated Emission in Restricted Bands and Spurious Emissions	15.247(d), 15.209 & 15.109	5.5	Pass	4.6
AC Power Line Conducted Emission	15.207 & 15.107	8.8#	Pass	4.7

Note: Pursuant to FCC Part 15 Section 15.215(c), the 20dB bandwidth of the emission was contained within the frequency band designated (mentioned as above) which the EUT operated. The effects, if any, from frequency sweeping, frequency hopping, other modulation techniques and frequency stability over expected variations in temperature and supply voltage were considered.

1.2 Statement of Compliance

The equipment under test is found to be complying with the following standard:

FCC Part 15, 2015 Edition
RSS-247 Issue 2, February 2017
RSS-Gen Issue 4, November 2014

INTERTEK TESTING SERVICES

**EXHIBIT 2
GENERAL DESCRIPTION**

INTERTEK TESTING SERVICES

2.0 General Description

2.1 Product Description

The Equipment Under Test (EUT) is a Tablet DVD Combo, equipped with DVD playback, headphone, WiFi, Bluetooth, SD, HDMI and USB Interface. The EUT is powered by an external AC/DC adaptor (9VDC output) or/and internal 3.7VDC (3.7V rechargeable battery). The adaptor accepts 100-240VAC. GPS, FM, NFC features will not be used in this product.

The Model: DRP2091 are the same as the Model: PVP1101 in hardware aspect. The difference in model number and brand name serves as marketing strategy.

For the WLAN (WiFi) module:

For 802.11b mode, it operates at frequency range of 2412MHz to 2462MHz with 11 channels. It transmits via direct-sequence spread spectrum (DSSS) modulation. Maximum bit rate can be up to 11Mbps. For 802.11g mode, it operates at frequency range of 2412MHz to 2462MHz with 11 channels. It transmits via Orthogonal Frequency Division Multiplexing (OFDM) modulation. Maximum bit rate can be up to 54Mbps. For 802.11n (HT20 with 20MHz bandwidth) mode, it operates at frequency range of 2412MHz to 2462MHz with 11 channels. It transmits via Orthogonal Frequency Division Multiplexing (OFDM) modulation (mcs0 to mcs7). Maximum bit rate can support up to 65Mbps. For 802.11n (HT40 with 40MHz bandwidth) mode, it operates at frequency range of 2422MHz to 2452MHz with 9 channels. It transmits via Orthogonal Frequency Division Multiplexing (OFDM) modulation (mcs0 to mcs7). Maximum bit rate can support up to 130Mbps.

For Bluetooth module:

For Bluetooth 4.0 BLE mode, it occupies a frequency range from 2402MHz to 2480MHz (40 channels with channel spacing of 2MHz). It transmits via GFSK modulation.

For Bluetooth 3.0 mode, it occupies a frequency range from 2402MHz to 2480MHz (79 channels with channel spacing of 1MHz). It transmits via GFSK modulation.

The antenna(s) used in the EUT is internal, integral.

The circuit description is saved with filename: descri.pdf.

INTERTEK TESTING SERVICES

2.2 Test Methodology

Both AC power line-conducted and radiated emission measurements were performed according to the procedures in ANSI C63.10 (2013). Preliminary radiated scans and all radiated measurements were performed in radiated emission test sites. All Radiated tests were performed at an antenna to EUT distance of 3 meters, unless stated otherwise in the "**Justification Section**" of this Application. Antenna port conducted measurements were performed according to ANSI C63.10 (2013) and KDB Publication No.558074 D01 v04 (05-April-2017). All other measurements were made in accordance with the procedures in 47 CFR Part 2 and RSS-Gen Issue 4 (2014).

2.3 Test Facility

The radiated emission test site, AC conducted emission test site and antenna port conducted measurement facility used to collect the radiated data and conductive data are at Workshop No. 3, G/F., World-Wide Industrial Centre, 43-47 Shan Mei Street, Fo Tan, Sha Tin, N.T., Hong Kong. This test facility and site measurement data have been fully placed on file with the FCC and the Industry Canada.

2.4 Related Submittal(s) Grants

This is a single application for certification of a transceiver.

The Declaration of the Conformity procedure of PC Connectivity for this transceiver (with FCC ID: A2HDRP2091) is being processed as the same time of this application.

INTERTEK TESTING SERVICES

**EXHIBIT 3
SYSTEM TEST CONFIGURATION**

INTERTEK TESTING SERVICES

3.0 System Test Configuration

3.1 Justification

For radiated emissions testing, the equipment under test (EUT) was setup to transmit / receive continuously to simplify the measurement methodology. Care was taken to ensure proper power supply voltages during testing. During testing, all cables (if any) were manipulated to produce worst case emissions.

The EUT was powered by 120VAC.

Two types of AC/DC adaptors were supplied by the applicant.

Model: GT-WCAL09000150-302, Brand: GST (worse case)

(Input: 100V-120VAC 0.5A 50-60Hz, Output: 9VDC 1.5A)

Model: GT-WLDU09000100-302, Brand: GST

(Input: 100V-120VAC 0.4A 50/60Hz, Output: 9VDC 1.0A)

All adaptors were tested and only worse case data is shown in this report.

For the measurements, the EUT was attached to a plastic stand if necessary and placed on the wooden turntable which is four feet in diameter and approximately 0.8m in height above the ground plane for emission measurement at or below 1GHz and 1.5m in height above the ground plane for emission measurement above 1GHz. If the EUT attached to peripherals, they were connected and operational (as typical as possible).

The rear of EUT shall be flushed with the rear of the table.

The signal was maximized through rotation and placement in the three orthogonal axes. The antenna height and polarization were varied during the search for maximum signal level. The antenna height was varied from 1 to 4 meters. Radiated emissions were taken at three meters unless the signal level was too low for measurement at that distance. If necessary, a pre-amplifier was used and/or the test was conducted at a closer distance.

For any intentional radiator powered by AC power line, measurements of the radiated signal level of the fundamental frequency component of the emission was performed with the supply voltage varied between 85% and 115% of the nominal rated supply voltage.

Radiated emission measurement for transmitter were performed from the lowest radio frequency signal generated in the device which is greater than 9 kHz to the tenth harmonic of the highest fundamental frequency or to 40 GHz, whichever is lower.

INTERTEK TESTING SERVICES

Justification – Cont'd

Emission that are directly caused by digital circuits in the transmit path and transmitter portion were measured, and the limit are according to FCC Part 15 Section 15.209/ RSS-247 2.5. Digital circuitries used to control additional functions other than the operation of the transmitter are subject to FCC Part 15 Section 15.109/ RSS-247 Section 5.5 Limits.

Detector function for radiated emissions was in peak mode. Average readings, when required, were taken by measuring the duty cycle of the equipment under test and subtracting the corresponding amount in dB from the measured peak readings. A detailed description for the calculation of the average factor can be found in section 4.2.3.

Determination of pulse desensitization was made according to *Hewlett Packard Application Note 150-2, Spectrum Analysis... Pulsed RF*. The effective period (Teff) was referred to Exhibit 4.6.3. With the resolution bandwidth 1MHz and spectrum analyzer IF bandwidth 3dB, the pulse desensitization factor was 0dB.

The EUT along with its peripherals were placed on a 1.0m(W)x1.5m(L) and 0.8m in height wooden table and the EUT was adjusted to maintain a 0.4 meter space from a vertical reference plane. The EUT power cord connected to one LISN (Line impedance stabilization network), which provided 50ohm coupling impedance for measuring instrument. Meanwhile, the peripheral or support equipment power cords connected to a separate LISN. The ac powers for all LISNs were obtained from the same power source. The LISN housing, measuring instrument case, reference ground plane, and vertical ground plane were bounded together. The excess power cable between the EUT and the LISN was bundled. Power cords of non-EUT equipment (peripherals) were not bundled. AC power cords of peripheral equipments draped over the rear edge of the table, and routed them down onto the floor of the ac power line conducted emission test site to the second LISN.

All connecting cables of EUT and peripherals were manipulated to find the maximum emission.

All configuration mode (with and without PC connectivity during transceiver test) and setting of data rate for 802.11b/g/n(HT20)/n(HT40) of WiFi mode had been considered, and worst case test data are shown on this test report (with PC connectivity).

For simultaneous transmission, both WiFi and Bluetooth portions are also switched on when taking radiated emission for determining worst-case spurious emission.

INTERTEK TESTING SERVICES

3.1 EUT Exercising Software

The EUT exercise program (if any) used during radiated and conducted testing was designed to exercise the various system components in a manner similar to a typical use.

3.2 Details of EUT and Description of Accessories

Details of EUT:

- 1 The EUT is powered by 120VAC

Description of Accessories:

1. Headphone of 1.2m long cable
2. 4GB USB Flash
3. 4GB Micro SD Card
4. HDMI Monitor
5. HDMI cable of 2m long
6. LAN cable of 2m long
7. HP Notebook Computer (Adaptor Model: HSTNN-CA15)
8. USB cable of 1m long
(Provided by Intertek)
9. AC/DC Adaptor
Model: GT-WCAL09000150-302, Brand: GST (worse case)
(Input: 100V-120VAC 0.5A 50/60Hz, Output: 9VDC 1.5A)
(Provided by Applicant)

3.3 Measurement Uncertainty

When determining of the test conclusion, the Measurement Uncertainty of test at a level of confidence of 95% has been considered. The values of the Measurement uncertainty for radiated emission test and RF conducted measurement test are $\pm 5.3\text{dB}$ and $\pm 0.99\text{dB}$ respectively. The value of the Measurement uncertainty for conducted emission test is $\pm 4.2\text{dB}$.

Uncertainty and Compliance - Unless the standard specifically states that measured values are to be extended by the measurement uncertainty in determining compliance, all compliance determinations are based on the actual measured value.

INTERTEK TESTING SERVICES

**EXHIBIT 4
TEST RESULTS**

INTERTEK TESTING SERVICES

4.0 Test Results

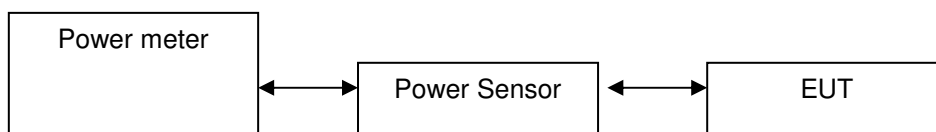

4.1 Maximum Conducted (peak) Output Power at Antenna Terminals

The antenna port of the EUT was connected to the input of a power meter.

- The antenna power of the EUT was connected to the input of a power meter. Power was read directly and cable loss correction was added to the reading to obtain power at the EUT antenna terminals. The measurement procedure 9.1.3 was used.
- The EUT should be configured to transmit continuously (at a minimum duty cycle of 98%) at full power over the measurement duration. The measurement procedure AVG1 was used.

IEEE 802.11b (DSSS, 1 Mbps) Antenna Gain = 2 dBi		
Frequency (MHz)	Output in dBm	Output in mWatt
Low Channel: 2412	16.6	45.7
Middle Channel: 2437	16.8	47.9
High Channel: 2462	17.2	52.5

IEEE 802.11g (OFDM, 6 Mbps) Antenna Gain = 2 dBi		
Frequency (MHz)	Output in dBm	Output in mWatt
Low Channel: 2412	17.0	50.1
Middle Channel: 2437	17.2	52.5
High Channel: 2462	17.8	60.3

IEEE 802.11n (HT20, MCS0) Antenna Gain = 2 dBi		
Frequency (MHz)	Output in dBm	Output in mWatt
Low Channel: 2412	17.2	52.5
Middle Channel: 2437	17.4	55.0
High Channel: 2462	18.0	63.1

INTERTEK TESTING SERVICES

4.1 Maximum Conducted (peak) Output Power at Antenna Terminals – Cont'd

IEEE 802.11n (HT40, mcs0) Antenna Gain = 2 dBi		
Frequency (MHz)	Output in dBm	Output in mWatt
Low Channel: 2422	16.4	43.7
Middle Channel: 2437	16.6	45.7
High Channel: 2452	16.8	47.9

Cable loss : 0.5 dB External Attenuation : 0 dB

IEEE 802.11b (DSSS, 1 Mbps)
max. conducted (peak) output level = 17.2 dBm

IEEE 802.11g (OFDM, 6 Mbps)
max. conducted (peak) output level = 17.8 dBm

IEEE 802.11n (HT20, mcs0)
max. conducted (peak) output level = 18.0 dBm

IEEE 802.11n ((HT40, mcs0)
max. conducted (peak) output level = 16.8 dBm

Limits:

1W (30dBm) for antennas with gains of 6dBi or less

___W (___dBm) for antennas with gains more than 6dBi

INTERTEK TESTING SERVICES

4.2 Minimum 6dB RF Bandwidth

The antenna port of the EUT was connected to the input of a spectrum analyzer. The EBW measurement procedure was used. A PEAK output reading was taken, a DISPLAY line was drawn 6dB lower than PEAK level. The 6dB bandwidth was determined from where the channel output spectrum intersected the display line.

IEEE 802.11b (DSSS, 1 Mbps)	
Frequency (MHz)	6dB Bandwidth (kHz)
Low Channel: 2412	10200
Middle Channel: 2437	10200
High Channel: 2462	10200

IEEE 802.11g (OFDM, 6 Mbps)	
Frequency (MHz)	6dB Bandwidth (kHz)
Low Channel: 2412	16560
Middle Channel: 2437	16560
High Channel: 2462	16560

IEEE 802.11n (HT20, MCS0)	
Frequency (MHz)	6dB Bandwidth (kHz)
Low Channel: 2412	17760
Middle Channel: 2437	17760
High Channel: 2462	17760

Limits:

6 dB bandwidth shall be at least 500kHz

INTERTEK TESTING SERVICES

4.2 Minimum 6dB RF Bandwidth – cont'd

The antenna port of the EUT was connected to the input of a spectrum analyzer. The EBW measurement procedure was used. A PEAK output reading was taken, a DISPLAY line was drawn 6dB lower than PEAK level. The 6dB bandwidth was determined from where the channel output spectrum intersected the display line.

IEEE 802.11n (HT40, MCS0)	
Frequency (MHz)	6dB Bandwidth (kHz)
Low Channel: 2422	36720
Middle Channel: 2442	36720
High Channel: 2452	36720

Limits

6 dB bandwidth shall be at least 500kHz

The plots of 6dB RF bandwidth and occupied bandwidth are saved as below.

INTERTEK TESTING SERVICES

Plots of 6dB RF bandwidth

802.11b, Lowest Channel

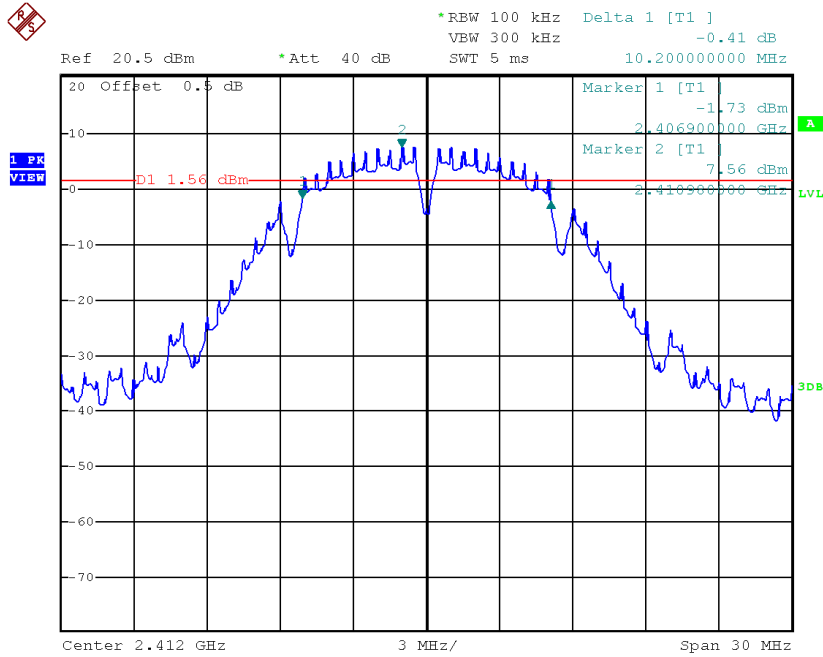

Date: 10.MAY.2017 06:22:07

802.11b, Middle Channel

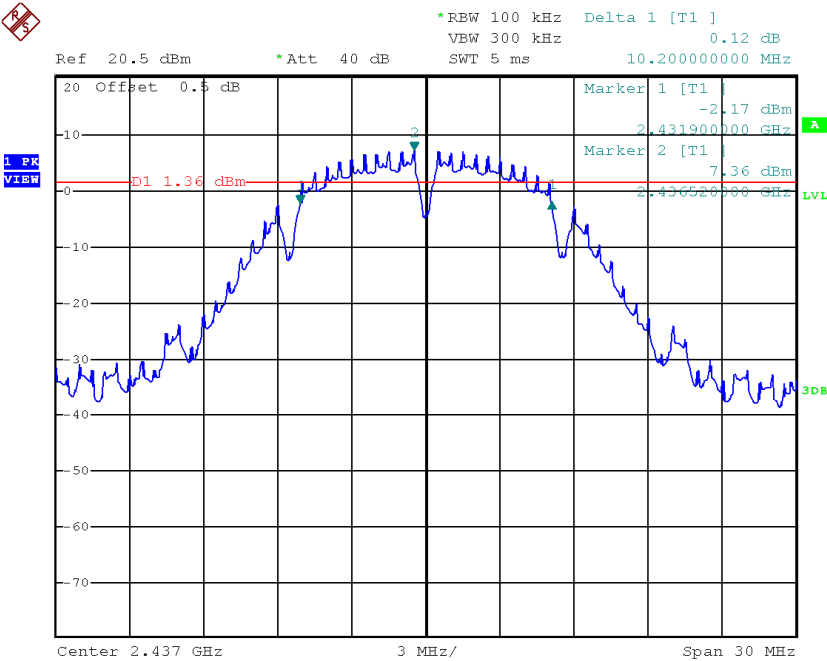

Date: 10.MAY.2017 06:24:11

INTERTEK TESTING SERVICES

Plots of 6dB RF bandwidth 802.11b, Highest Channel

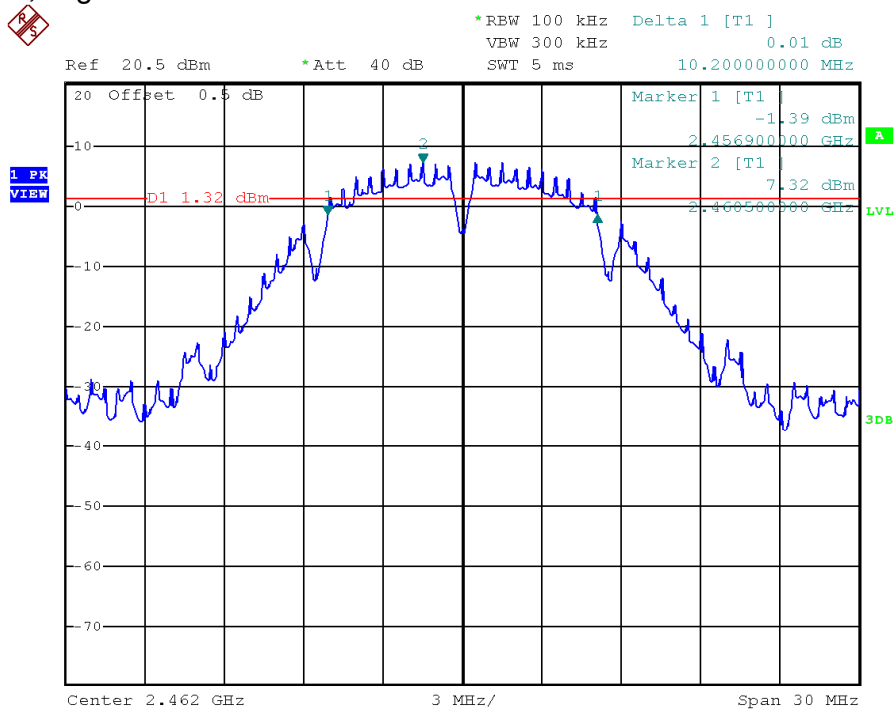

Date: 10.MAY.2017 06:25:53

INTERTEK TESTING SERVICES

Plots of 6dB RF bandwidth

802.11g, Lowest Channel

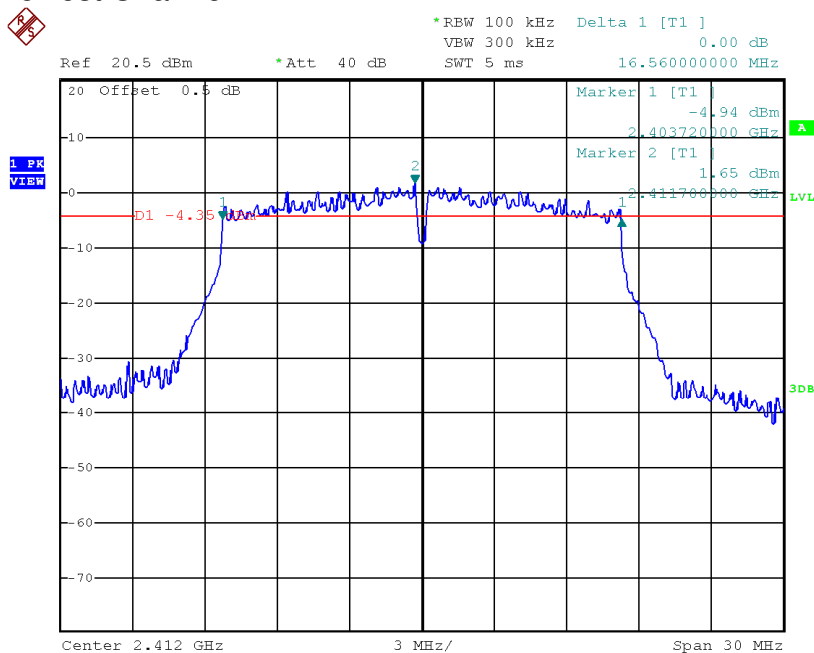

Date: 10.MAY.2017 06:33:08

802.11g, Middle Channel

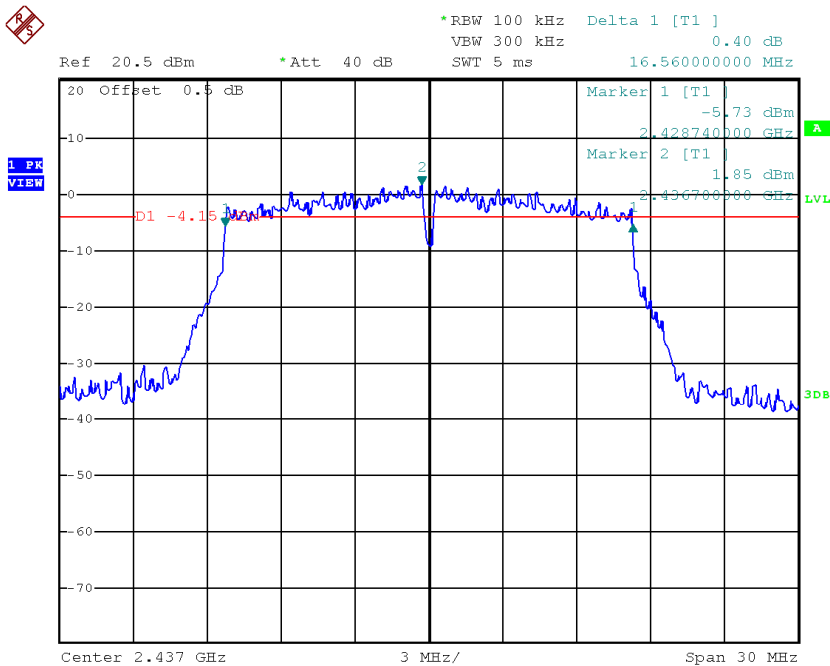

Date: 10.MAY.2017 06:36:01

INTERTEK TESTING SERVICES

Plots of 6dB RF bandwidth

802.11g, Highest Channel

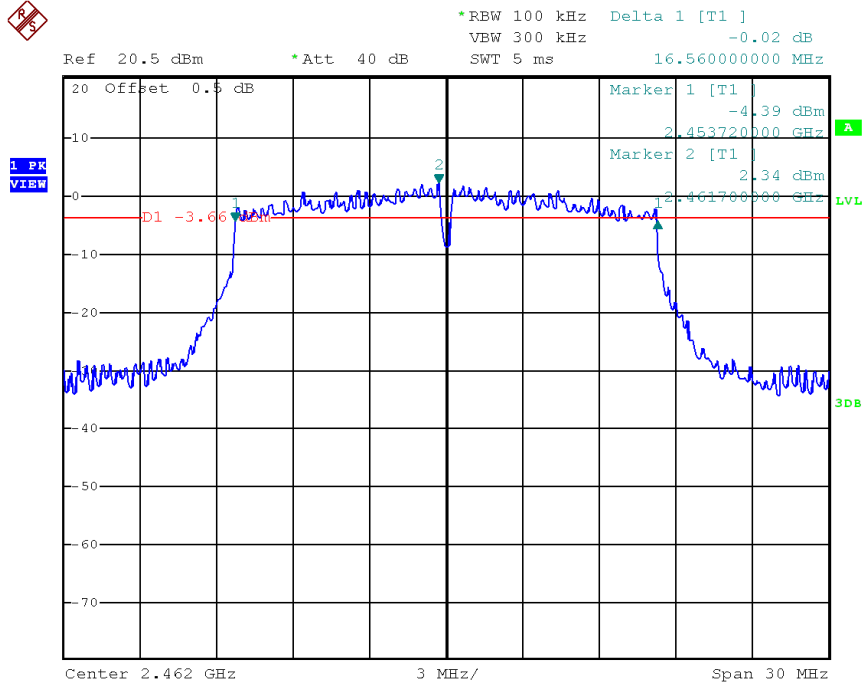

Date: 10.MAY.2017 06:37:50

INTERTEK TESTING SERVICES

Plots of 6dB RF bandwidth 802.11n(HT20), Lowest Channel

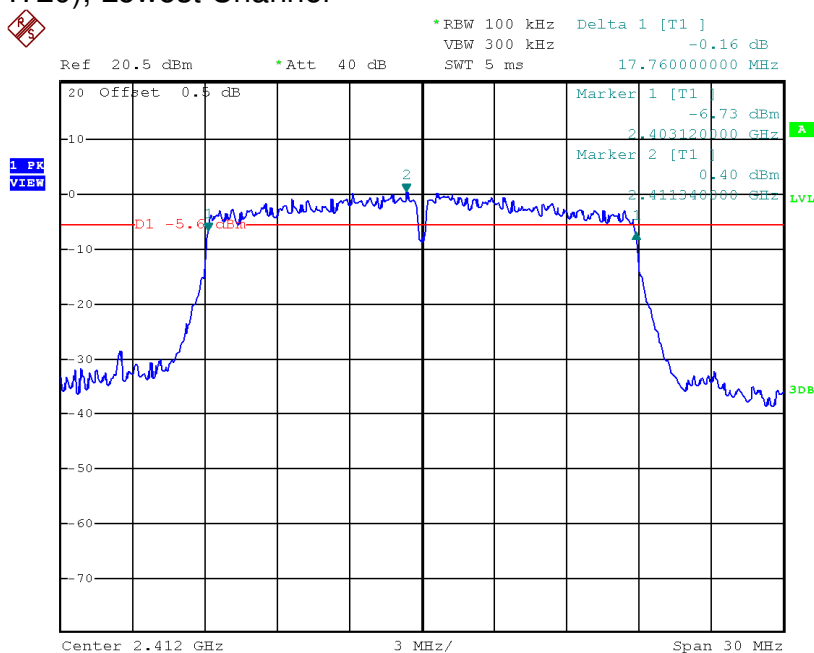

Date: 10.MAY.2017 06:43:15

802.11n(HT20), Middle Channel

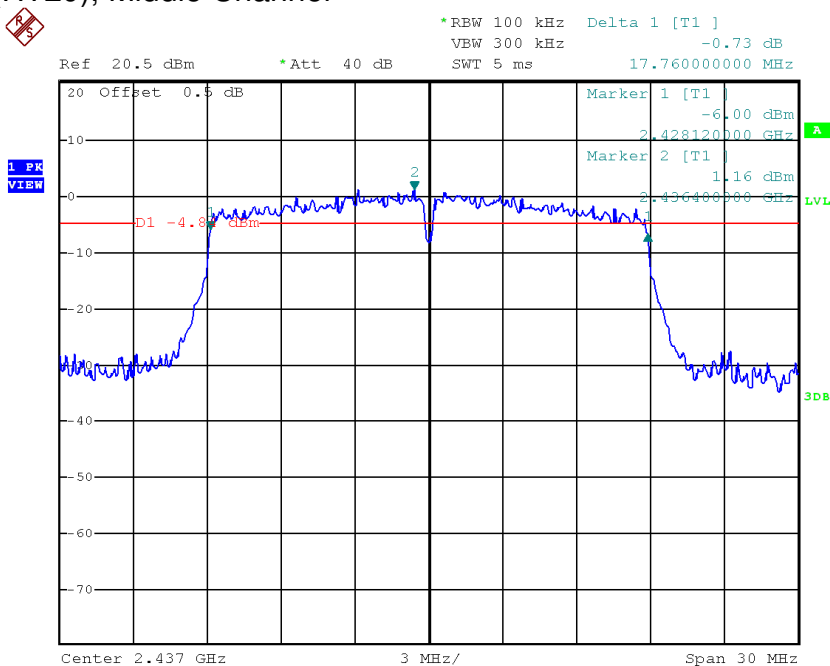

Date: 10.MAY.2017 06:44:35

INTERTEK TESTING SERVICES

Plots of 6dB RF bandwidth 802.11n(HT20), Highest Channel

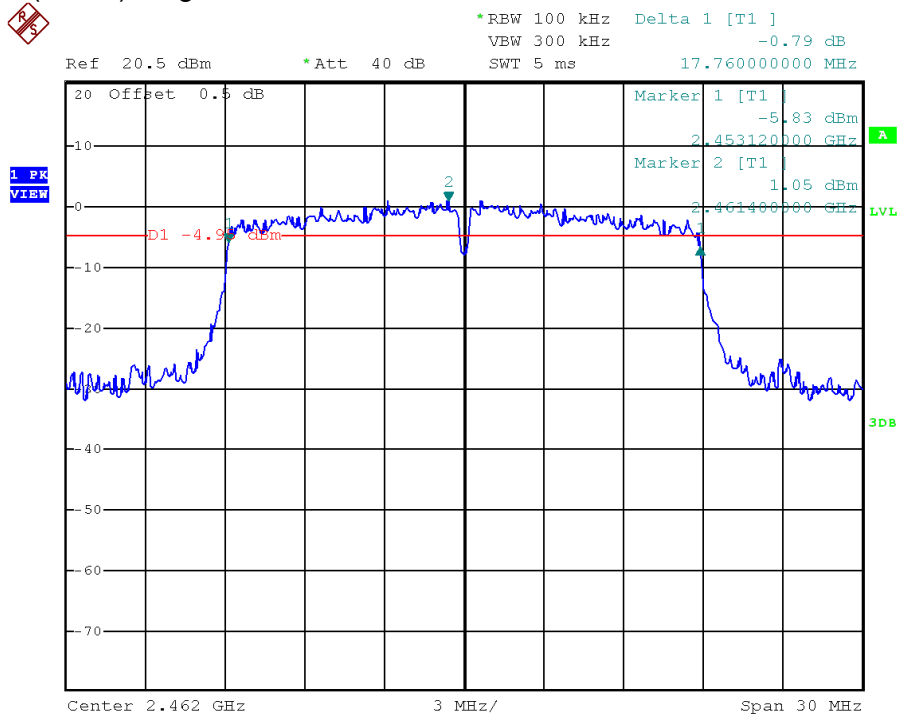

Date: 10.MAY.2017 06:46:08

Plots of 6dB RF bandwidth

802.11n(HT40), Lowest Channel

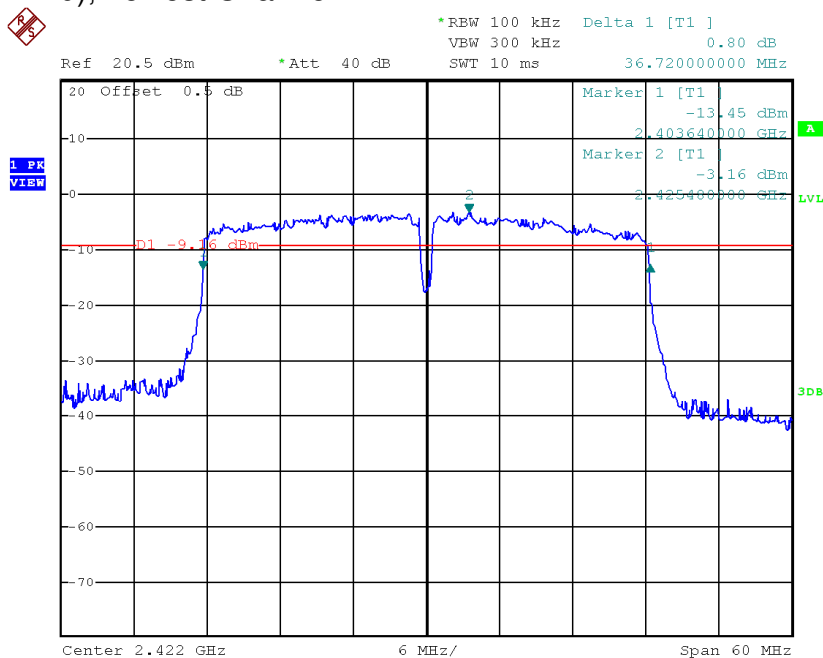

Date: 10.MAY.2017 08:13:43

802.11n(HT40), Middle Channel

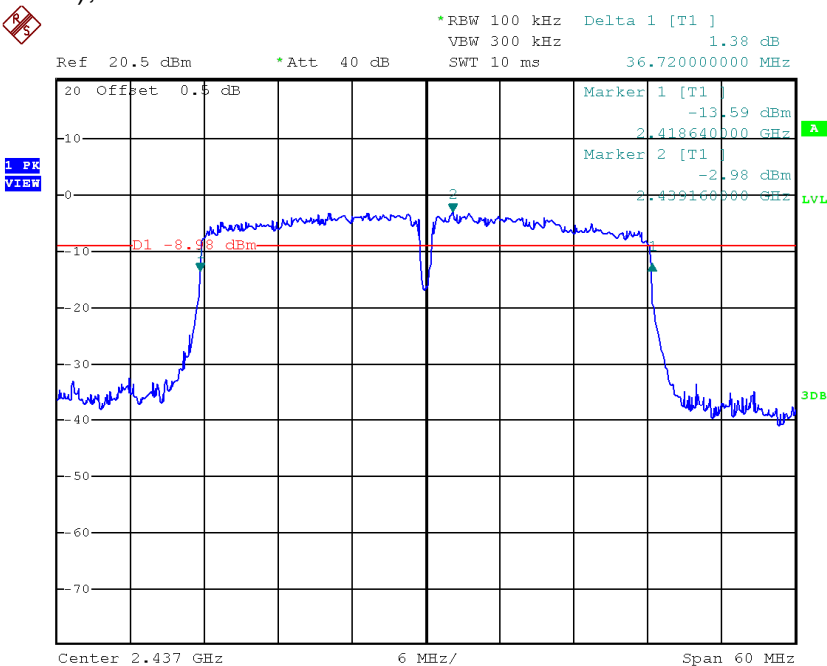

Date: 10.MAY.2017 08:20:18

INTERTEK TESTING SERVICES

Plots of 6dB RF bandwidth 802.11n(HT40), Highest Channel

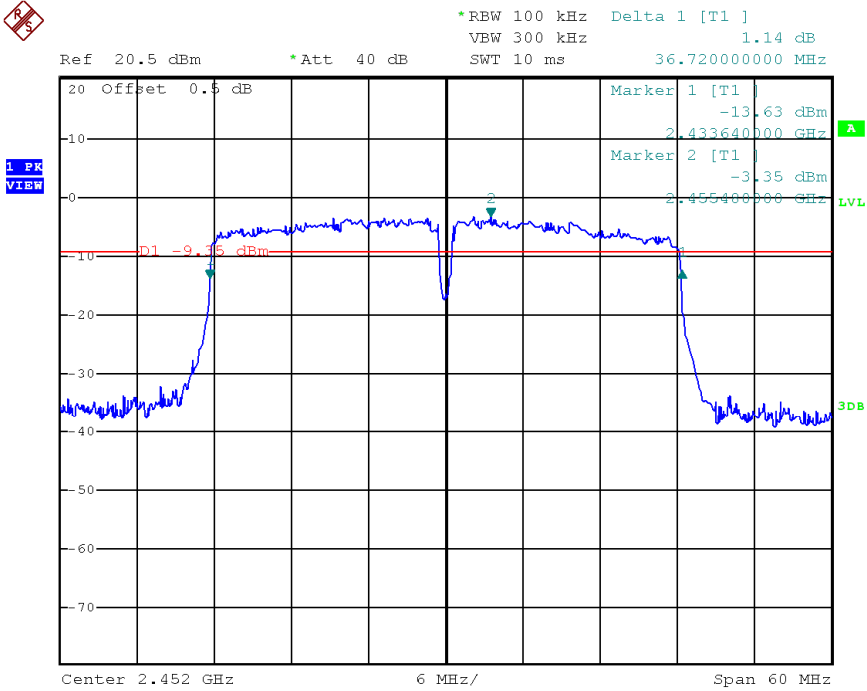

Date: 10.MAY.2017 08:16:44

INTERTEK TESTING SERVICES

4.3 Maximum Power Spectral Density

Antenna output of the EUT was coupled directly to spectrum analyzer. The measurement procedure 10.2 PKPSD-1 was used. If an external attenuator and/or cable was used, these losses are compensated for using the OFFSET function of the analyser.

IEEE 802.11b (DSSS, 1 Mbps)	
Frequency (MHz)	PSD in 100kHz (dBm)
Low Channel: 2412	7.42
Middle Channel: 2442	7.48
High Channel: 2462	7.68

IEEE 802.11g (OFDM, 6 Mbps)	
Frequency (MHz)	PSD in 100kHz (dBm)
Low Channel: 2412	1.80
Middle Channel: 2442	1.98
High Channel: 2462	2.82

IEEE 802.11n (HT20, MCS0)	
Frequency (MHz)	PSD in 100kHz (dBm)
Low Channel: 2412	0.78
Middle Channel: 2442	1.46
High Channel: 2462	1.16

IEEE 802.11n (HT40, MCS0)	
Frequency (MHz)	PSD in 100kHz (dBm)
Low Channel: 2422	-3.32
Middle Channel: 2442	-2.75
High Channel: 2452	-3.08

Cable Loss: 0.5 dB

Limit:
8dBm

INTERTEK TESTING SERVICES

Plots of power spectral density

802.11b, Lowest channel

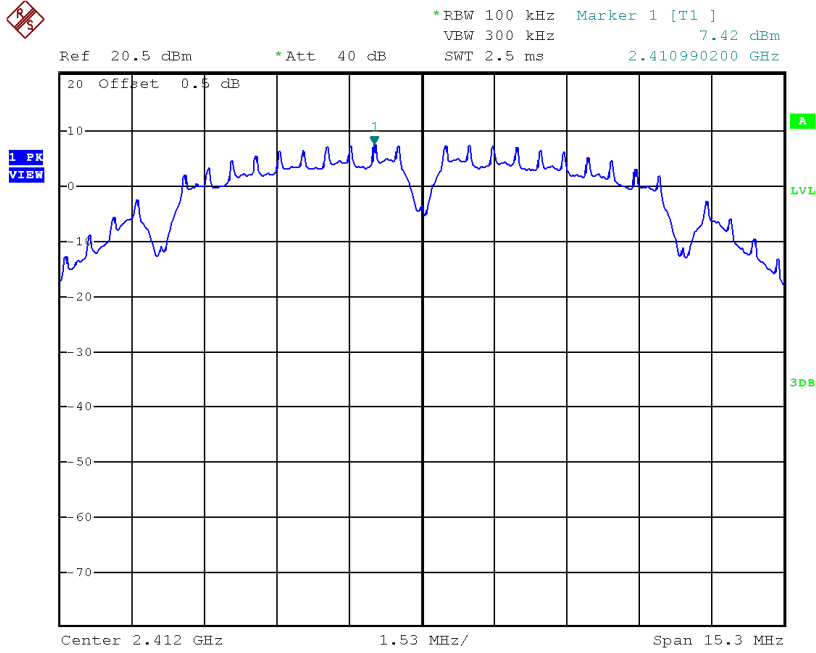

Date: 11.MAY.2017 05:05:54

802.11b, Middle channel

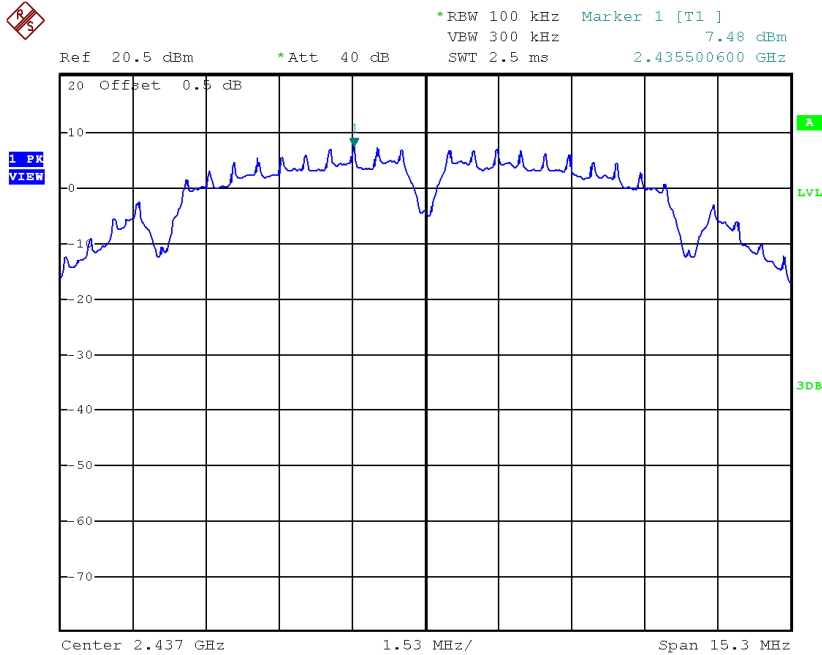

Date: 11.MAY.2017 05:08:18

INTERTEK TESTING SERVICES

Plots of power spectral density 802.11b, Highest channel

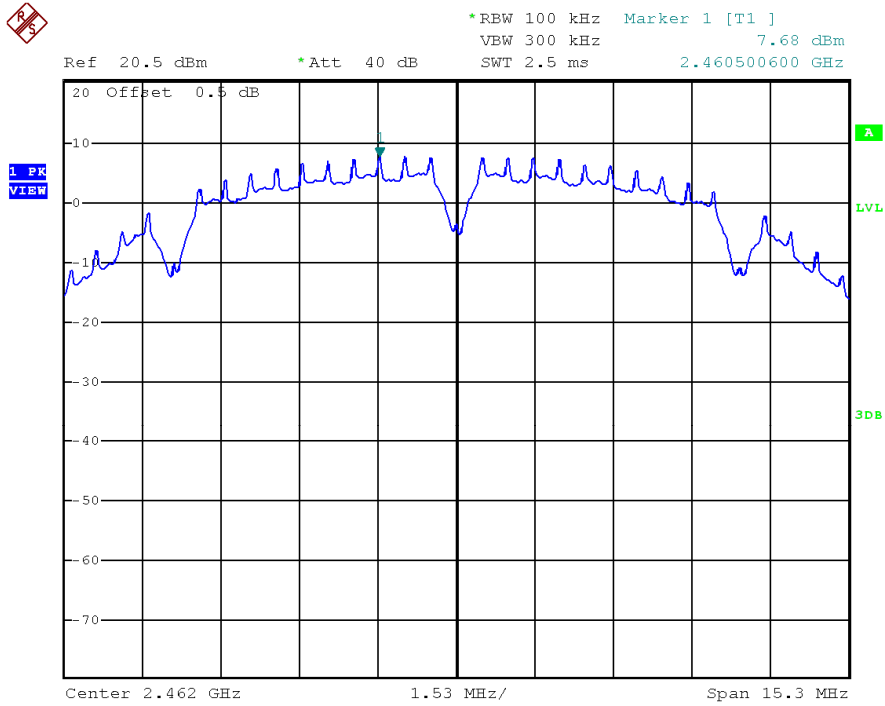

Date: 11.MAY.2017 05:09:07

INTERTEK TESTING SERVICES

Plots of power spectral density

802.11g, Lowest channel

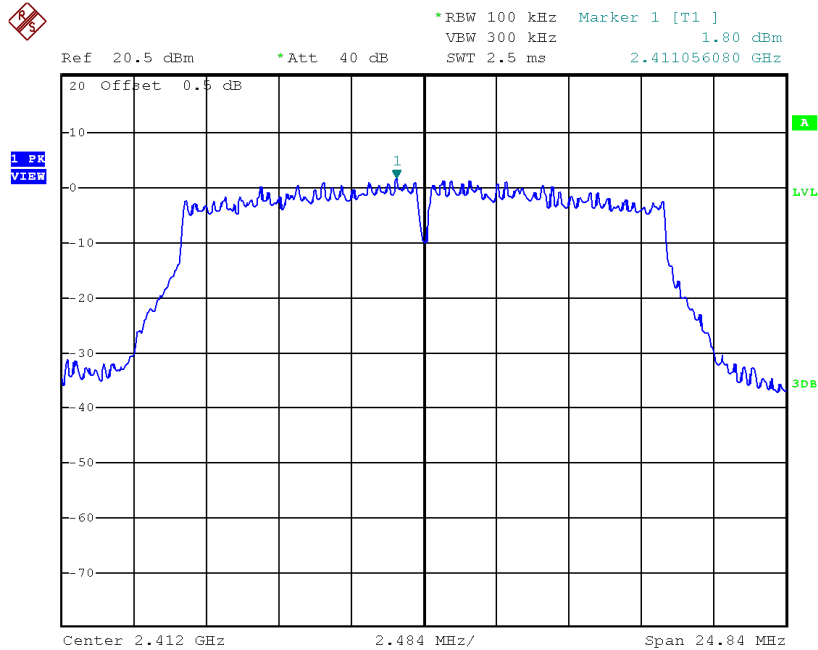

Date: 11.MAY.2017 05:12:43

802.11g, Middle channel

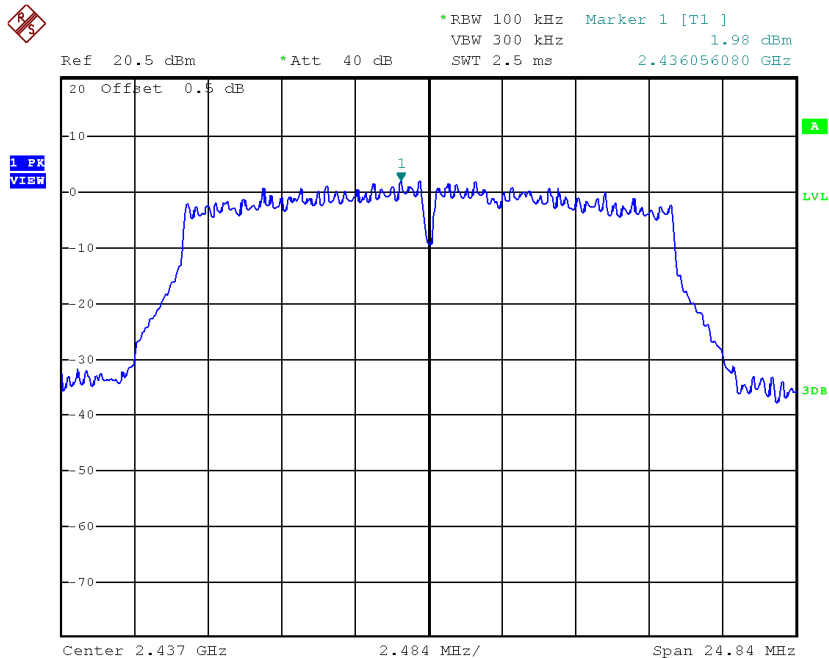

Date: 11.MAY.2017 05:13:35

INTERTEK TESTING SERVICES

Plots of power spectral density

802.11g, Highest channel

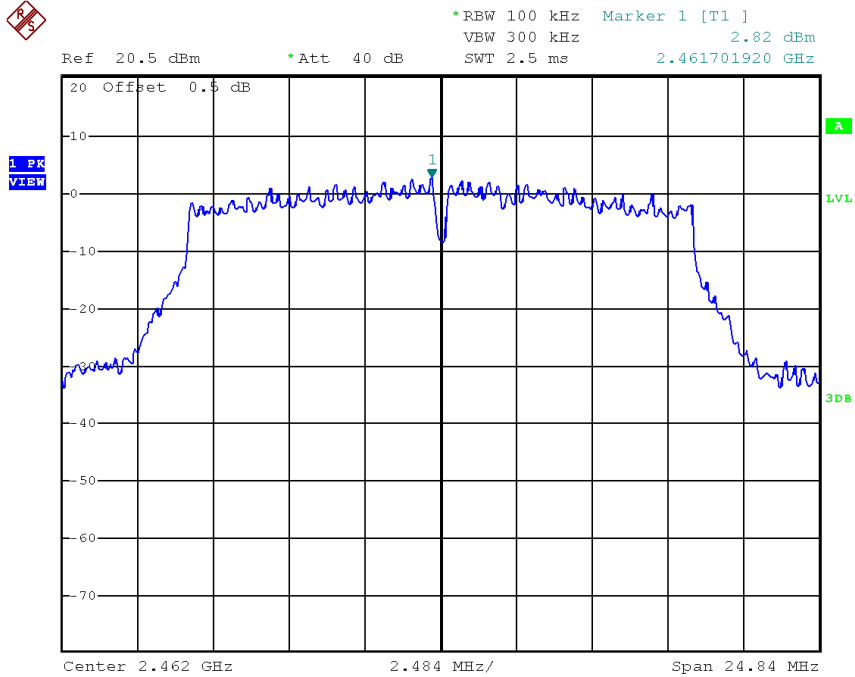

Date: 11.MAY.2017 05:14:35

INTERTEK TESTING SERVICES

Plots of power spectral density

802.11n(HT20), Lowest channel

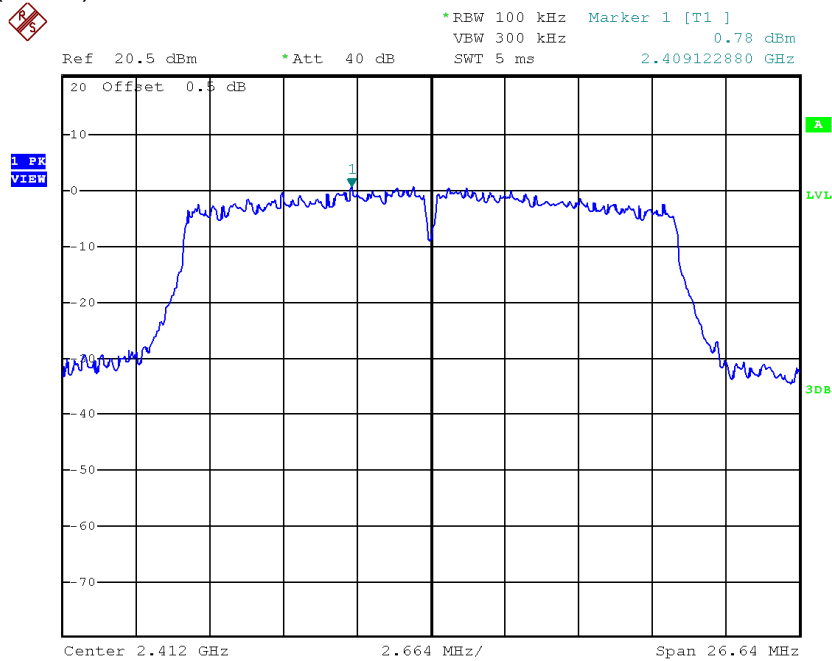

Date: 11.MAY.2017 05:15:39

802.11n(HT20), Middle channel

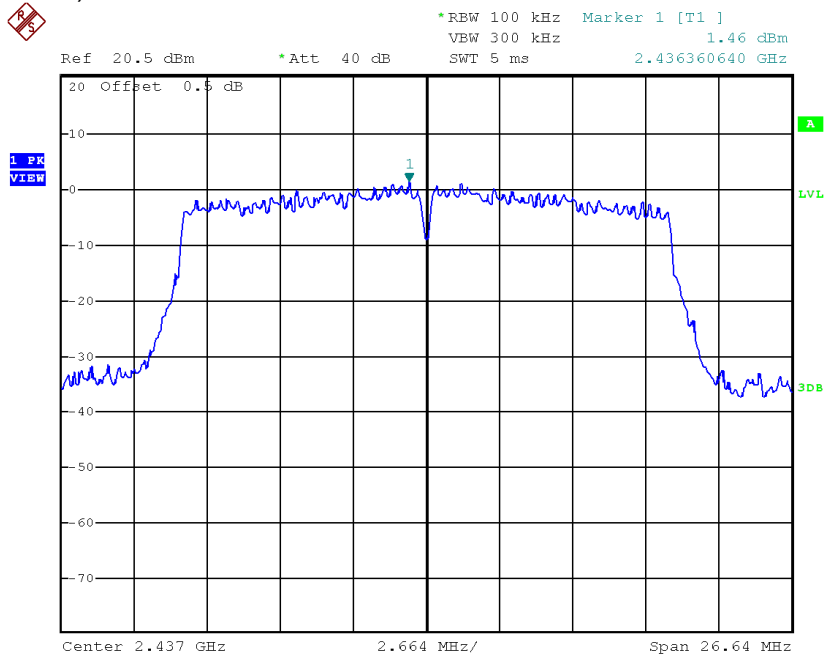

Date: 11.MAY.2017 05:17:00

INTERTEK TESTING SERVICES

Plots of power spectral density

802.11n(HT20), Highest channel



*RBW 100 kHz Marker 1 [T1]
VBW 300 kHz 1.16 dBm
SWT 5 ms 2.461360640 GHz

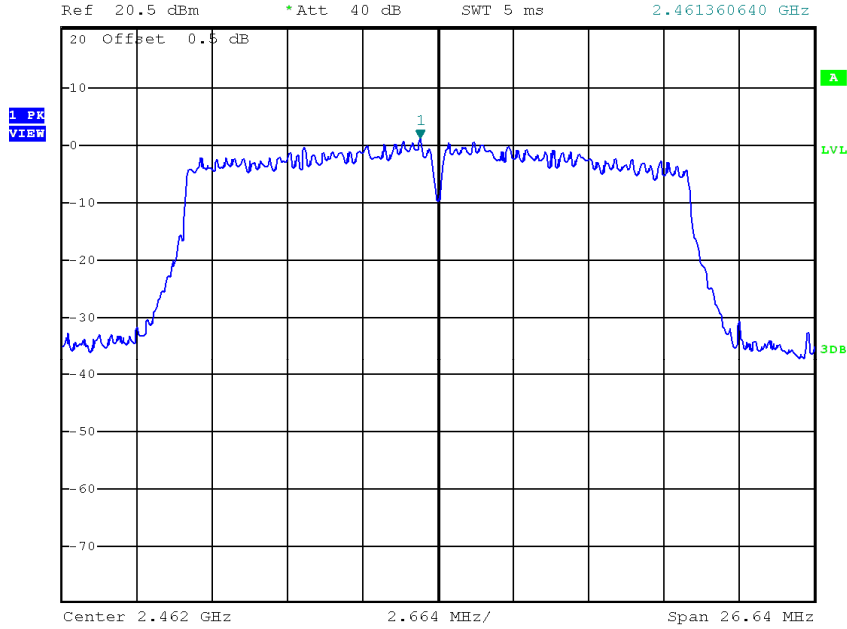

Date: 11.MAY.2017 05:18:19

INTERTEK TESTING SERVICES

Plots of power spectral density

802.11n(HT40), Lowest channel

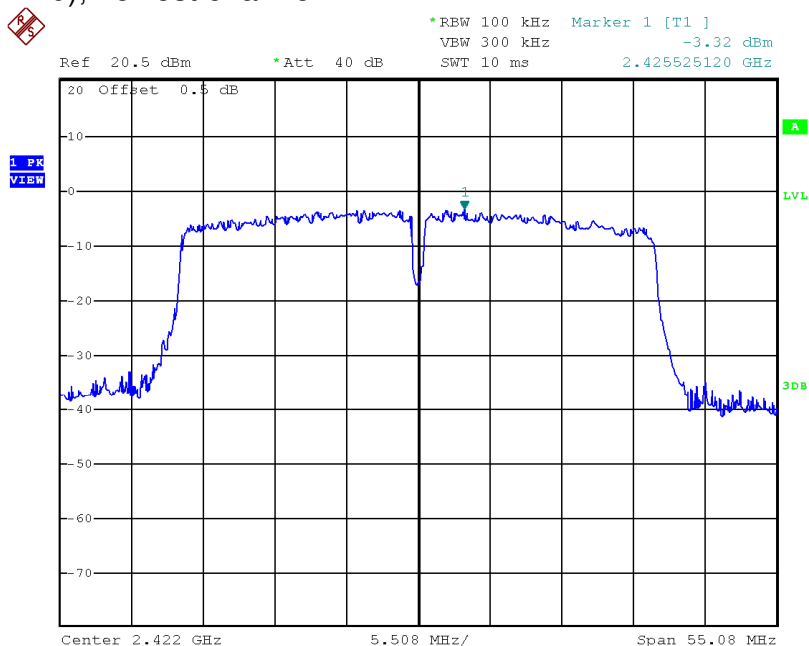

Date: 11.MAY.2017 05:21:46

802.11n(HT40), Middle channel

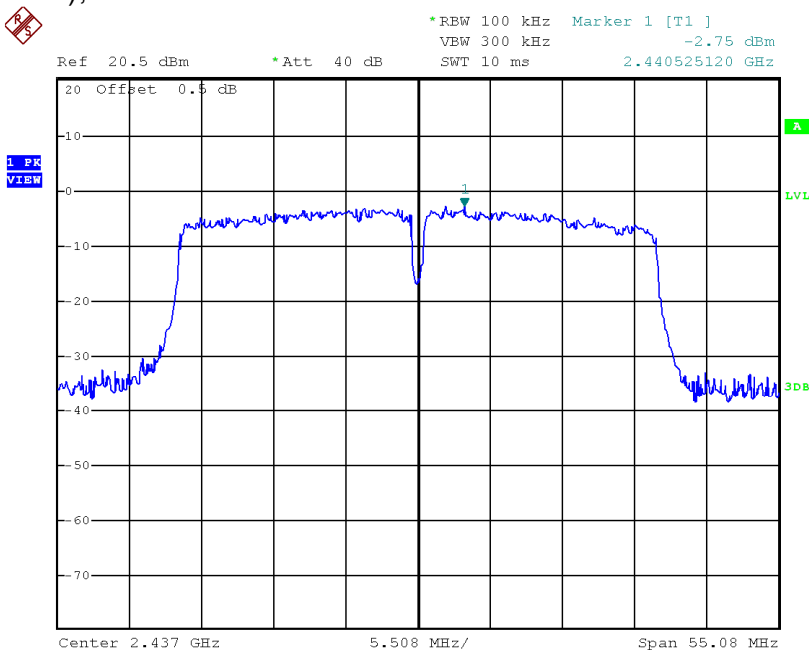

Date: 11.MAY.2017 05:22:37

INTERTEK TESTING SERVICES

Plots of power spectral density

802.11n(HT40), Highest channel



*RBW 100 kHz Marker 1 [T1]
VBW 300 kHz -3.08 dBm
SWT 10 ms 2.455525120 GHz

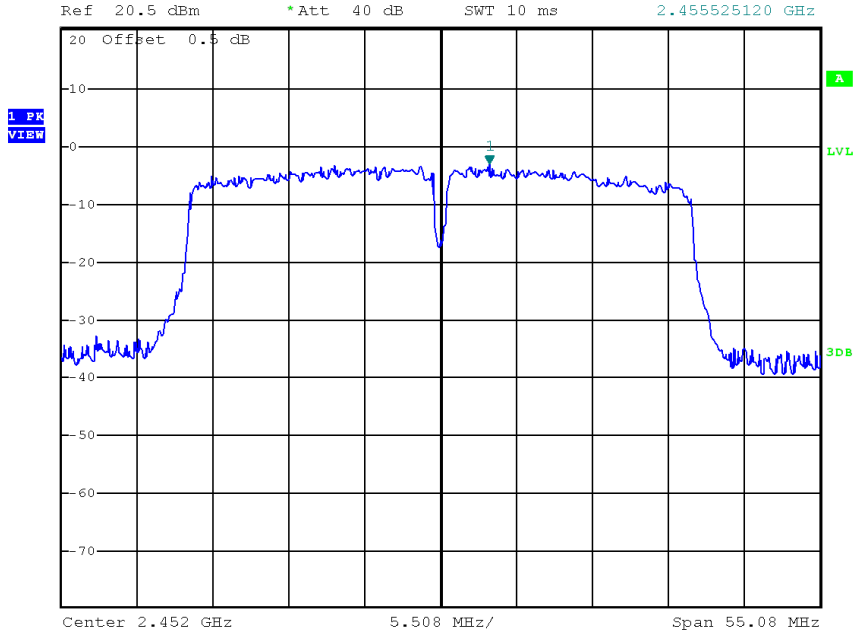

Date: 11.MAY.2017 05:23:34

INTERTEK TESTING SERVICES

4.4 Out of Band Conducted Emissions

The maximum conducted (peak) output power was used to demonstrate compliance as described in 9.1. Then the display line (in red) shown in the following plots denotes the limit at 20dB below maximum measured in-band peak PSD level in 100 KHz bandwidth.

The measurement procedures under sections 11 of KDB558074 D01 v04 (05-April-2017) were used.

Furthermore, delta measurement technique for measuring bandedge emissions was incorporated in the test of the edge at 2483.5MHz.

Limits:

All spurious emission and up to the tenth harmonic was measured and they were found to be at least 20 dB below the maximum measured in-band peak PSD level.

The plots of out of band conducted emissions are as below.

INTERTEK TESTING SERVICES

Plots of out of band conducted emissions

802.11b, Lowest Channel, Plot A

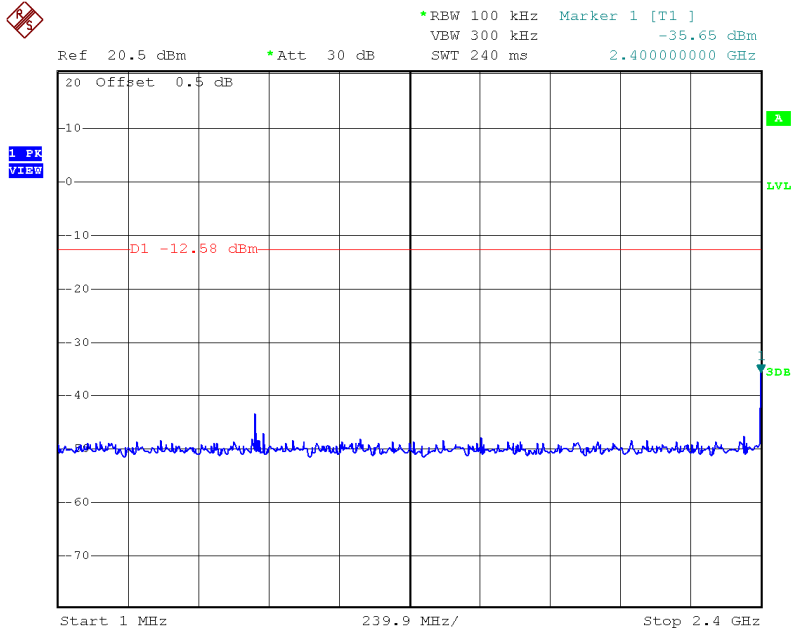

Date: 11.MAY.2017 17:55:12

802.11b, Lowest Channel, Plot B

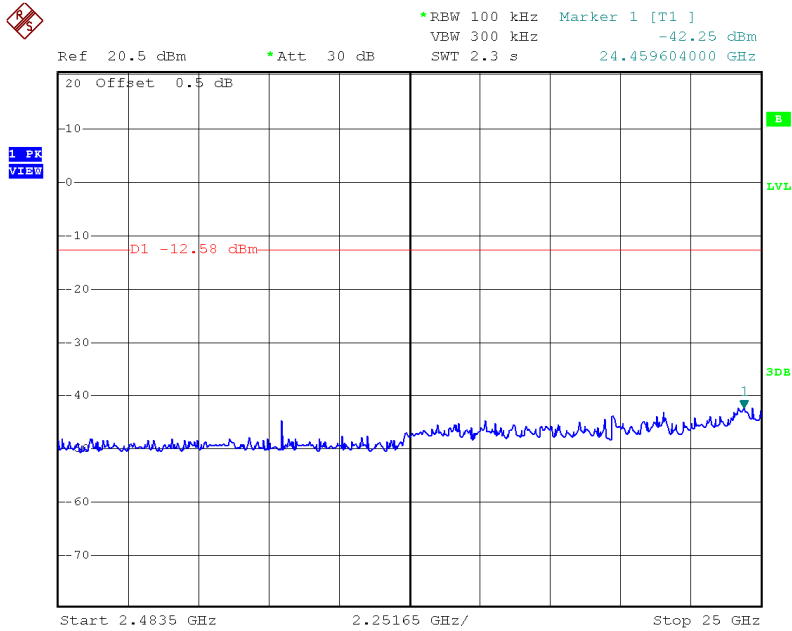

Date: 11.MAY.2017 17:56:03

INTERTEK TESTING SERVICES

Plots of out of band conducted emissions

802.11b, Middle Channel, Plot A

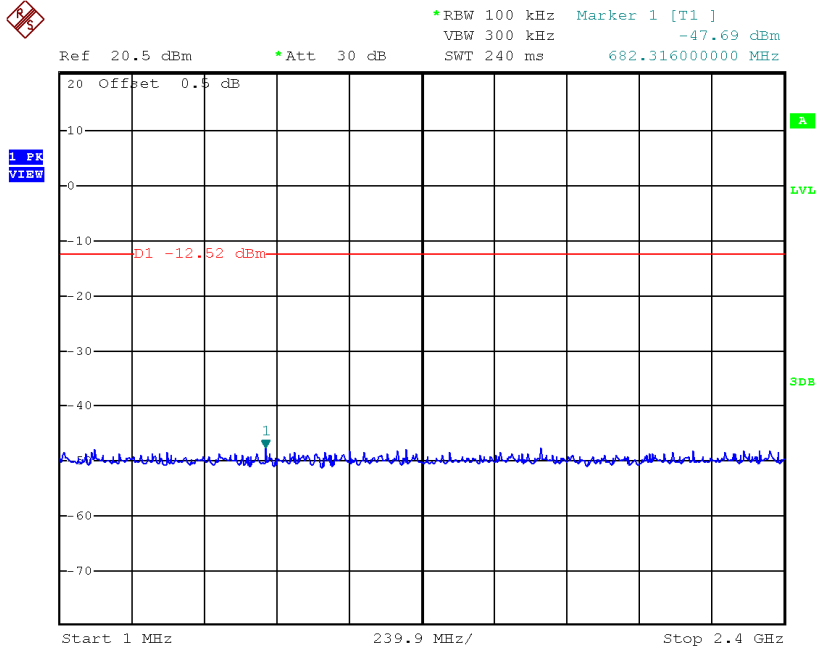

Date: 16.MAY.2017 11:29:09

802.11b, Middle Channel, Plot B

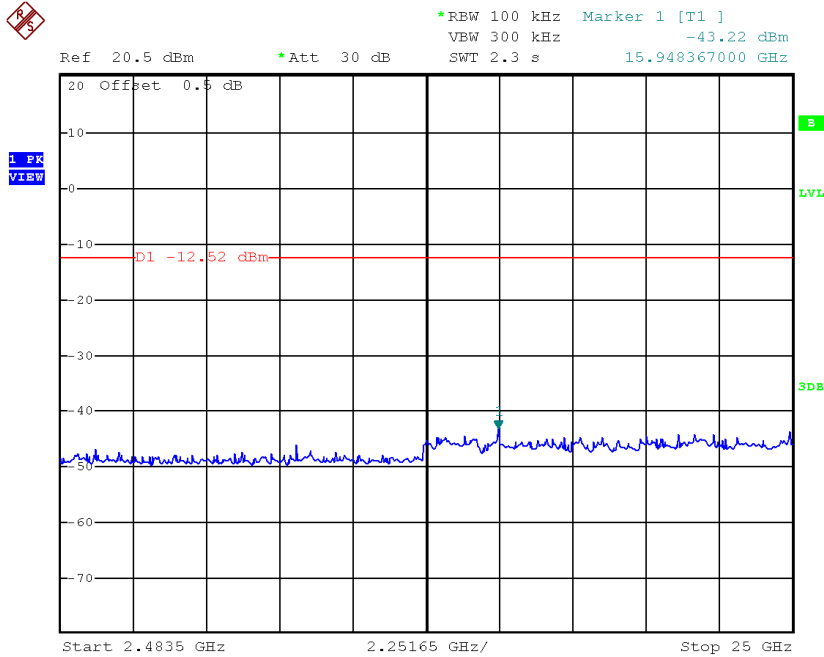

Date: 16.MAY.2017 11:31:21

INTERTEK TESTING SERVICES

Plots of out of band conducted emissions

802.11b, Highest Channel, Plot A

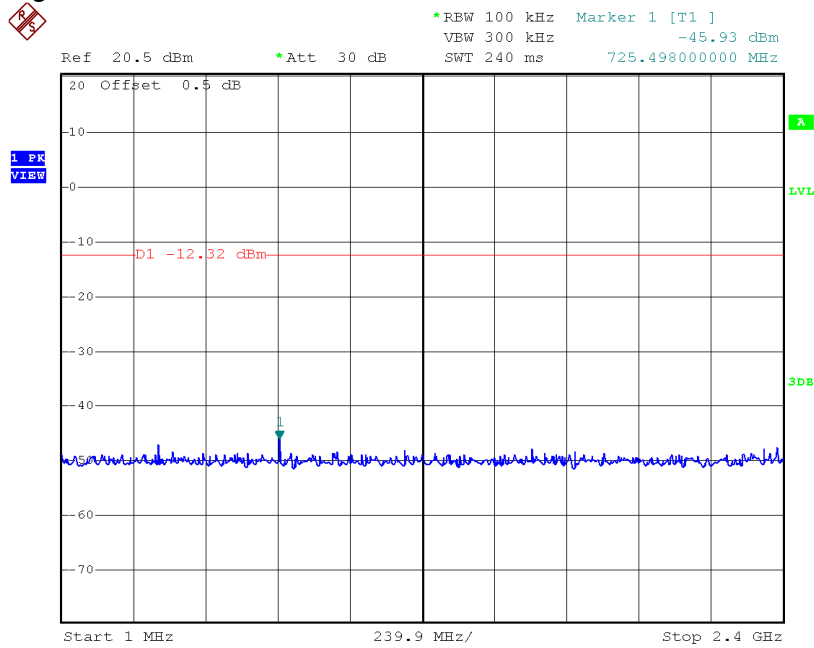

Date: 11.MAY.2017 17:57:42

802.11b, Highest Channel, Plot B

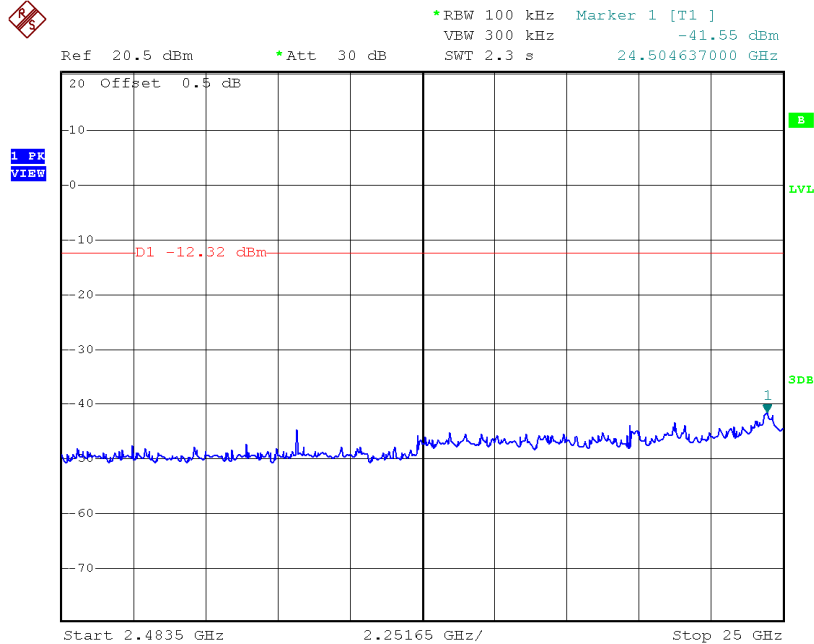

Date: 11.MAY.2017 17:57:00

INTERTEK TESTING SERVICES

Plots of out of band conducted emissions

802.11g, Lowest Channel, Plot A

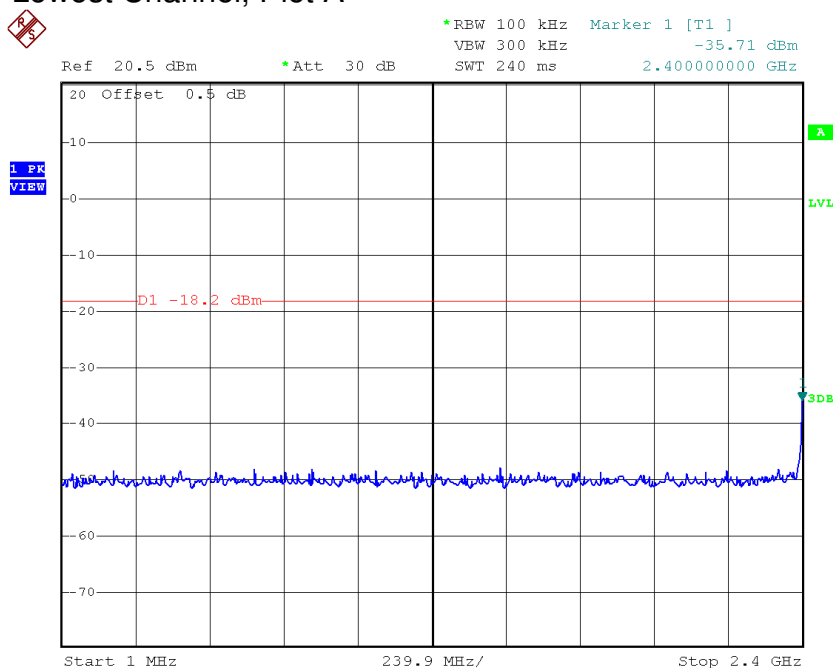

Date: 11.MAY.2017 17:58:37

802.11g, Lowest Channel, Plot B

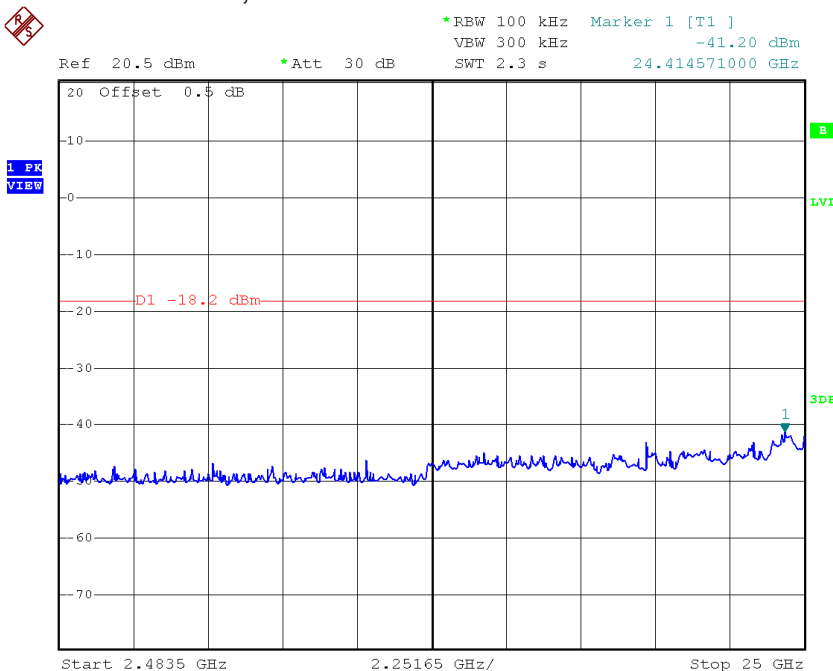

Date: 11.MAY.2017 17:59:45

INTERTEK TESTING SERVICES

Plots of out of band conducted emissions

802.11g, Middle Channel, Plot A

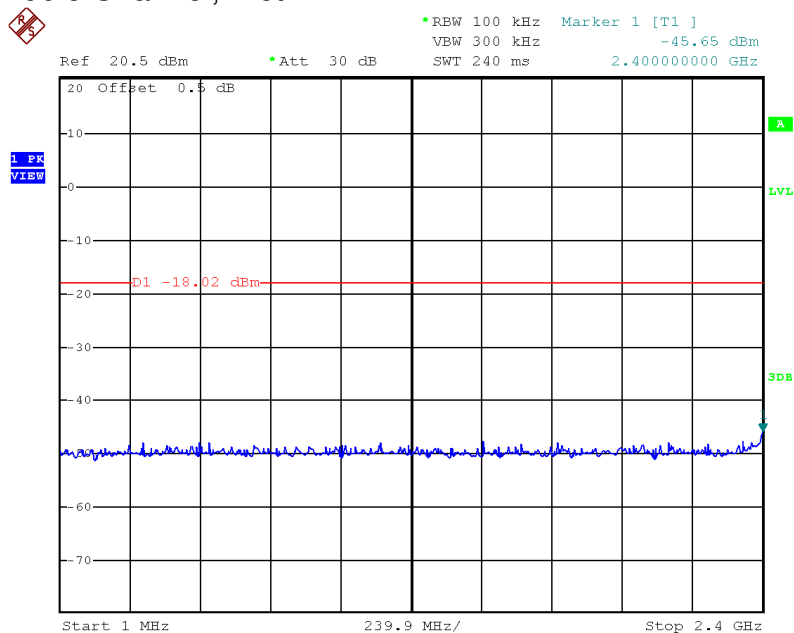

Date: 16.MAY.2017 11:34:21

802.11g, Middle Channel, Plot B

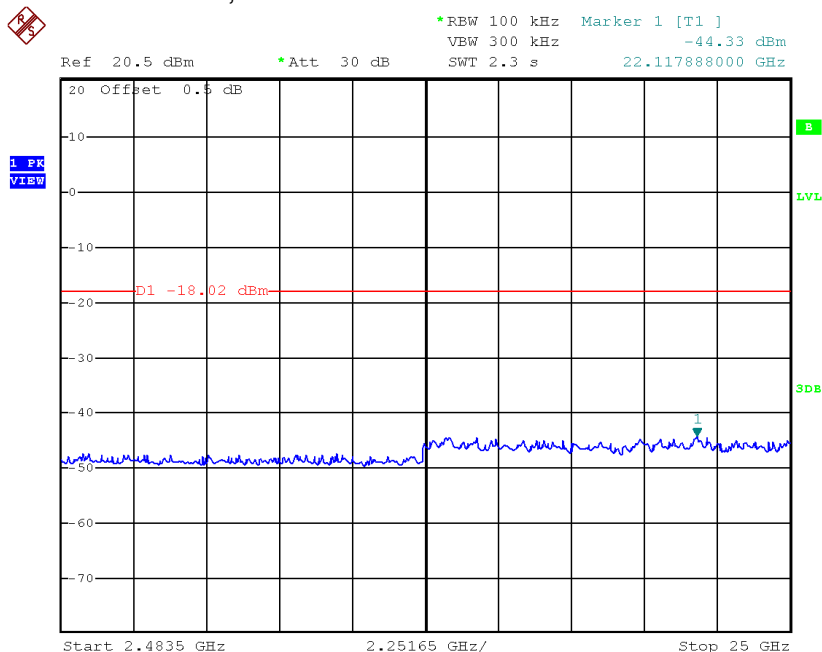

Date: 16.MAY.2017 11:33:04

INTERTEK TESTING SERVICES

Plots of out of band conducted emissions

802.11g, Highest Channel, Plot A

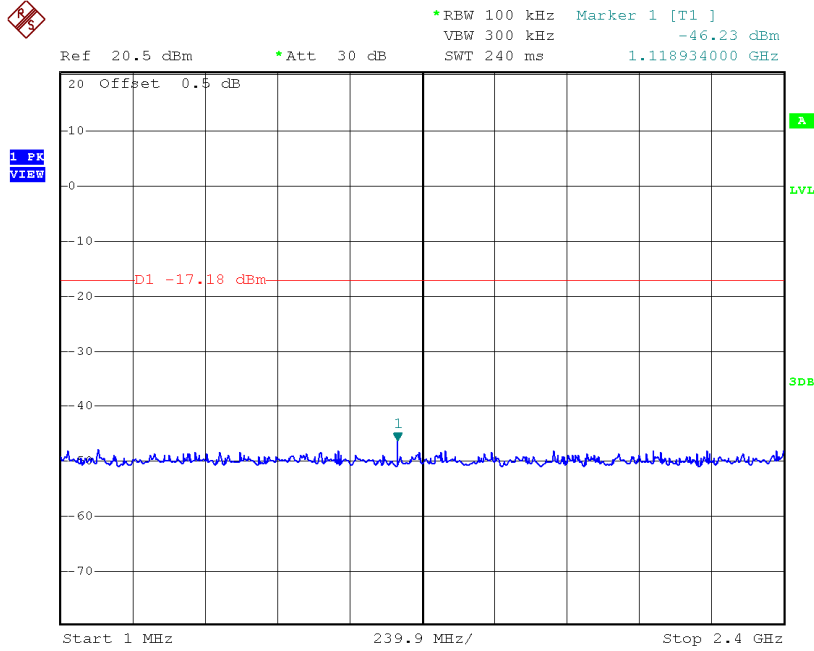

Date: 11.MAY.2017 18:03:36

802.11g, Highest Channel, Plot B

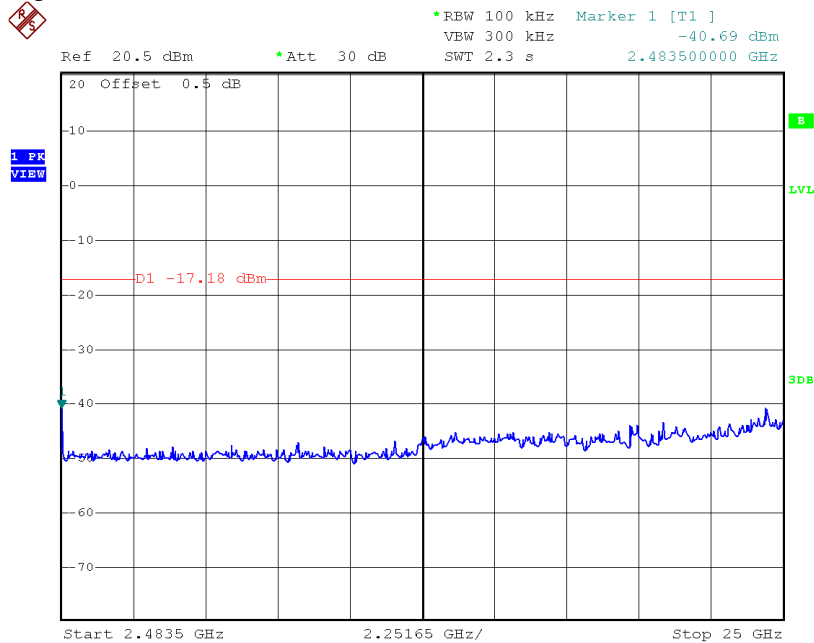

Date: 11.MAY.2017 18:03:07

INTERTEK TESTING SERVICES

Plots of out of band conducted emissions

802.11n (HT20), Lowest Channel, Plot A

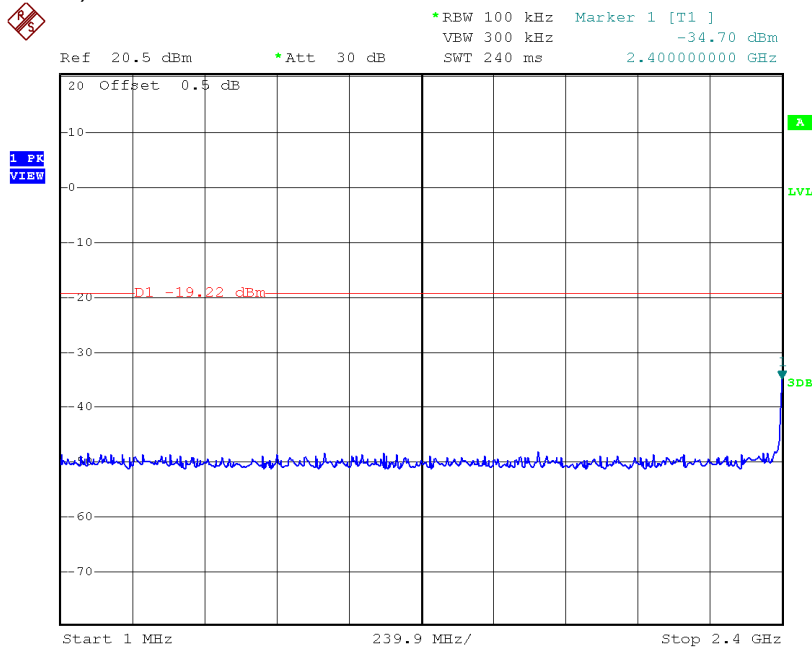

Date: 11.MAY.2017 18:04:38

802.11n (HT20), Lowest Channel, Plot B

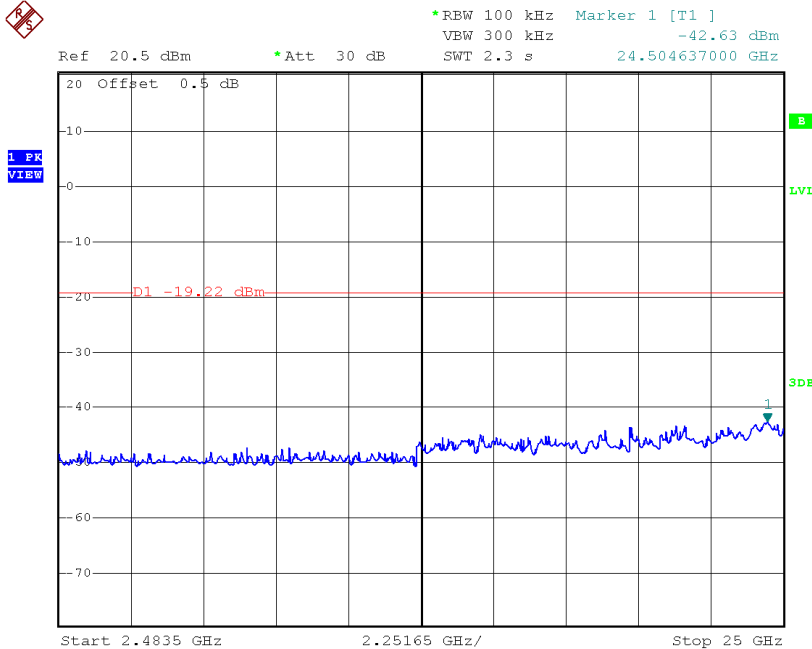

Date: 11.MAY.2017 18:05:25

INTERTEK TESTING SERVICES

Plots of out of band conducted emissions

802.11n (HT20), Middle Channel, Plot A

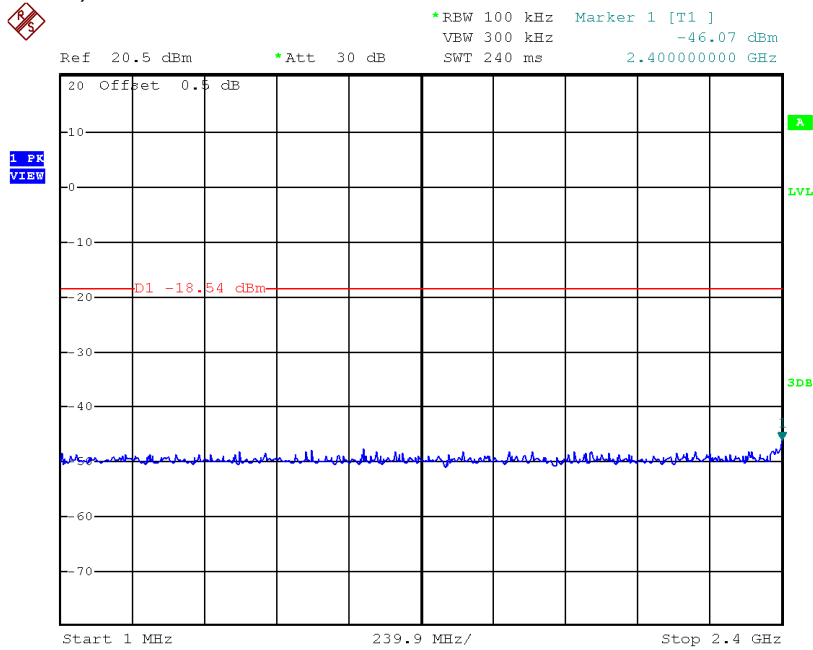

Date: 16.MAY.2017 11:35:24

802.11n (HT20), Middle Channel, Plot B

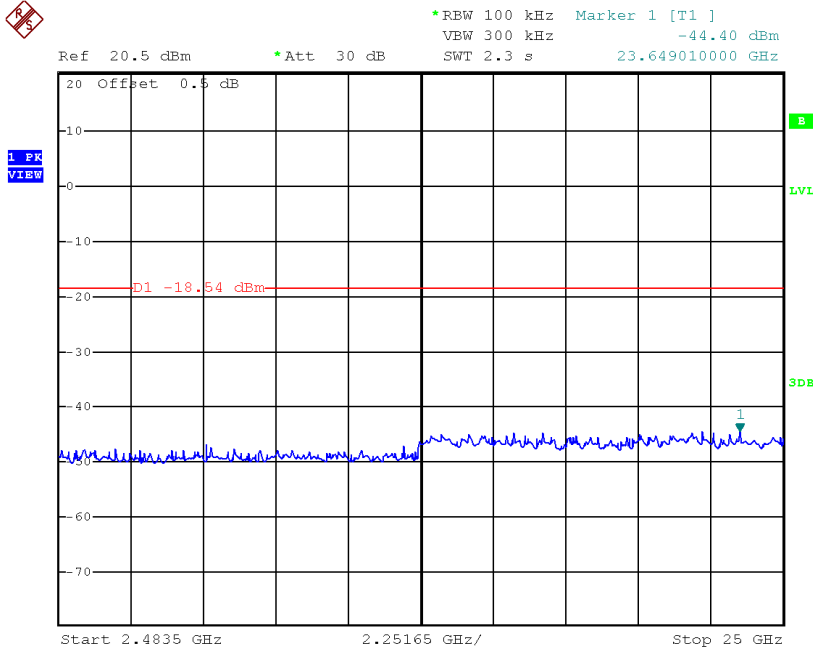

Date: 16.MAY.2017 11:36:32

INTERTEK TESTING SERVICES

Plots of out of band conducted emissions

802.11n (HT20), Highest Channel, Plot A

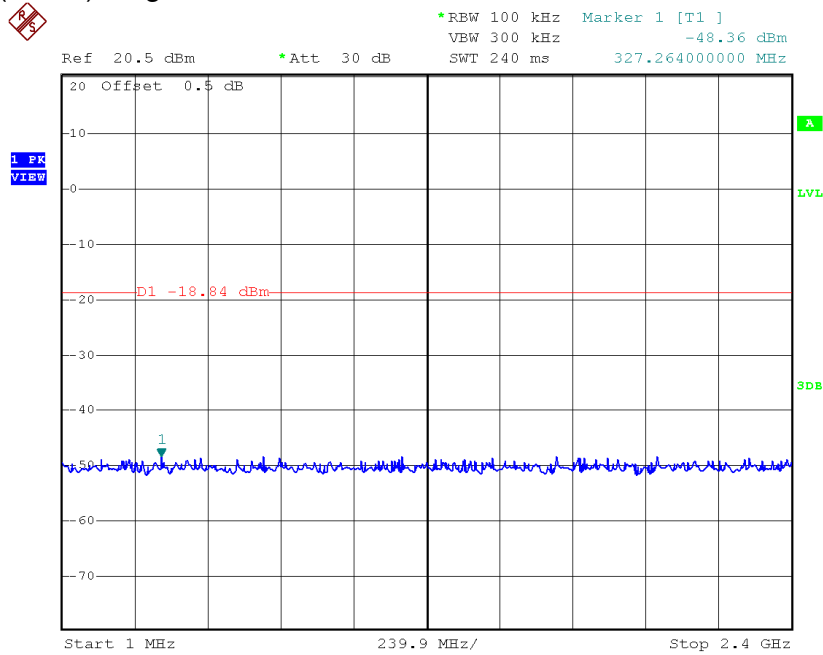

Date: 11.MAY.2017 18:07:01

802.11n (HT20), Highest Channel, Plot B

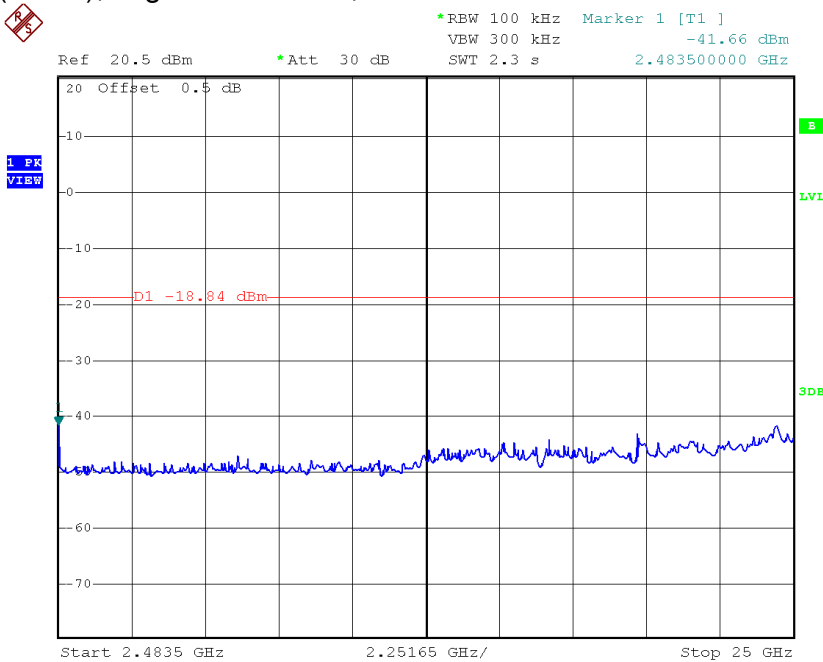

Date: 11.MAY.2017 18:06:17

INTERTEK TESTING SERVICES

Plots of out of band conducted emissions

802.11n (HT40), Lowest Channel, Plot A

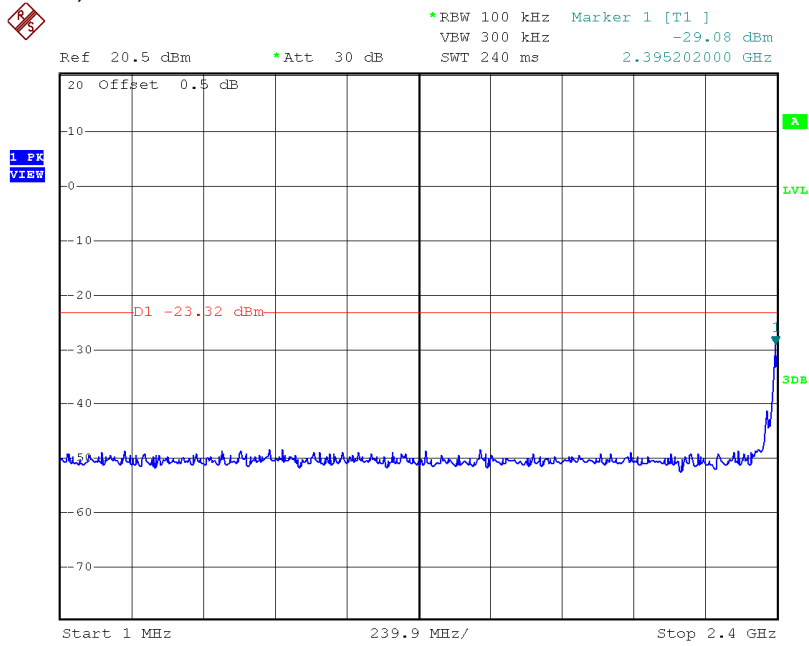

Date: 11.MAY.2017 18:08:04

802.11n (HT40), Lowest Channel, Plot B

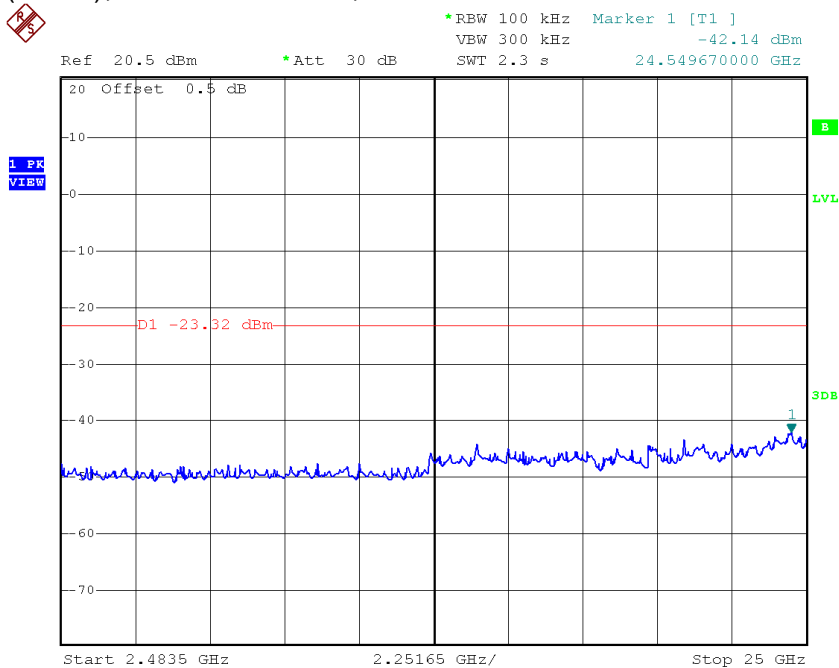

Date: 11.MAY.2017 18:09:07

INTERTEK TESTING SERVICES

Plots of out of band conducted emissions

802.11n (HT40), Middle Channel, Plot A

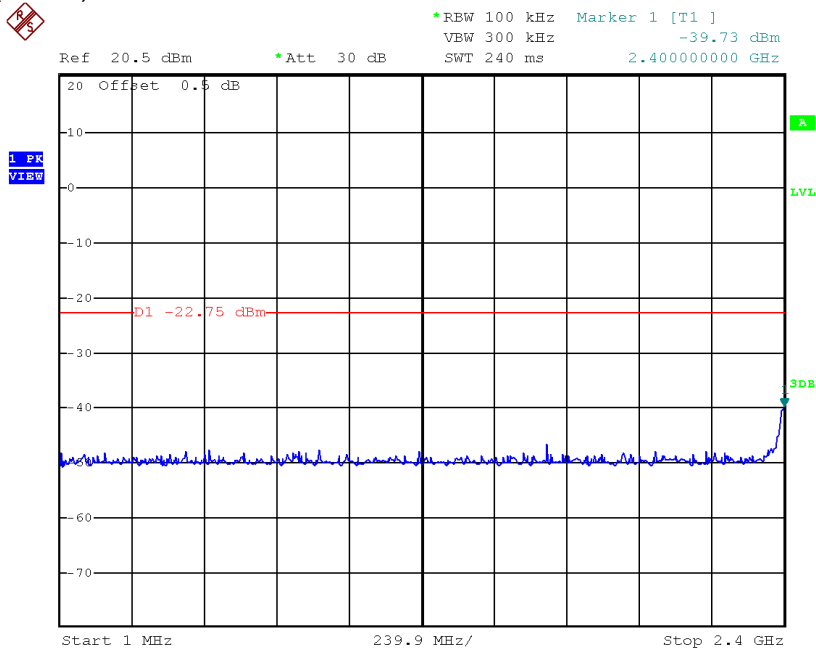

Date: 16.MAY.2017 11:39:24

802.11n (HT40), Middle Channel, Plot B

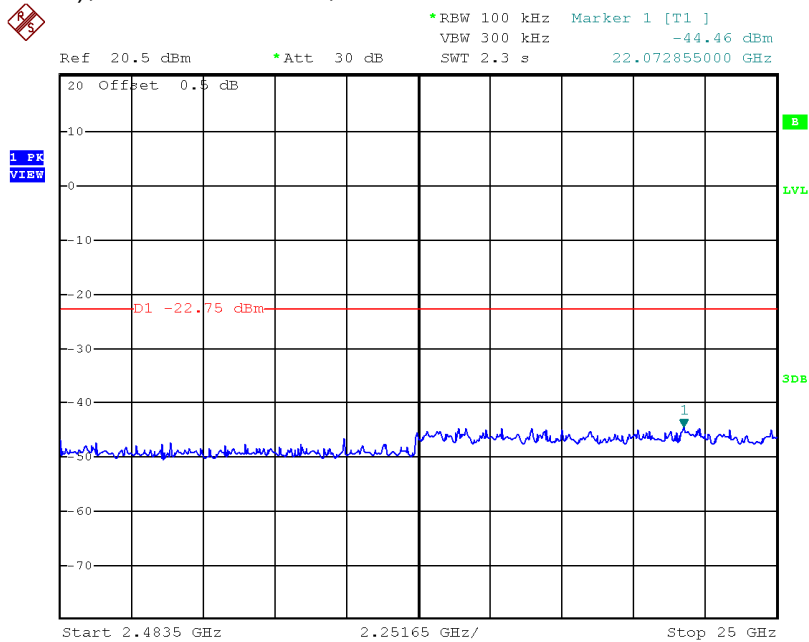

Date: 16.MAY.2017 11:38:22

INTERTEK TESTING SERVICES

Plots of out of band conducted emissions

802.11n (HT40), Highest Channel, Plot A

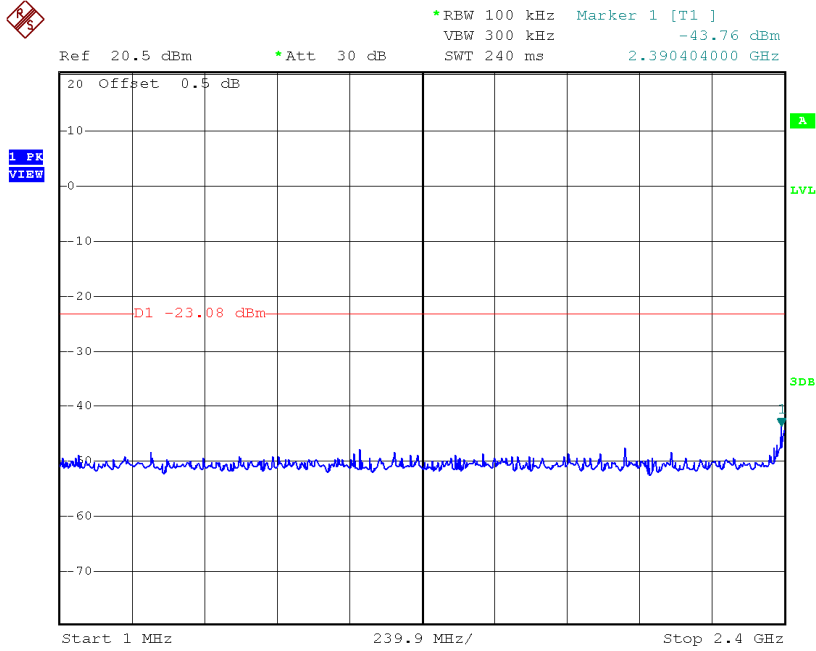

Date: 11.MAY.2017 18:11:56

802.11n (HT40), Highest Channel, Plot B

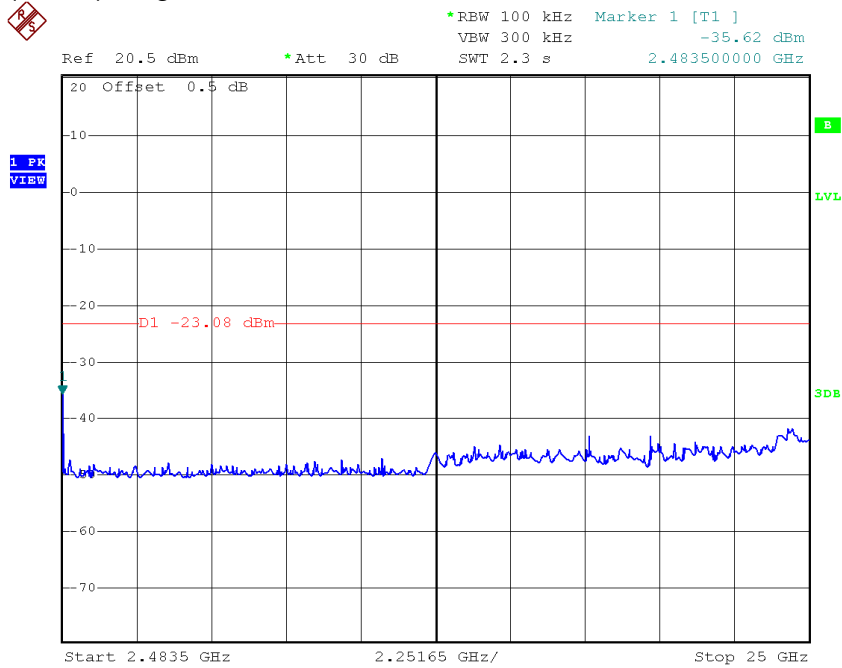

Date: 11.MAY.2017 18:10:14

INTERTEK TESTING SERVICES

Plots of Bandedge

802.11b, Lowest Channel

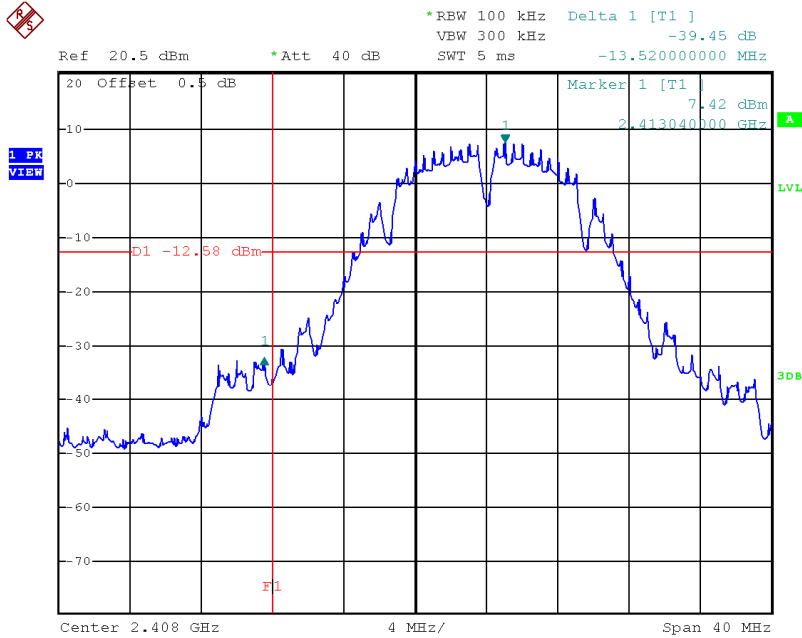

Date: 11.MAY.2017 05:37:15

802.11b, Highest Channel

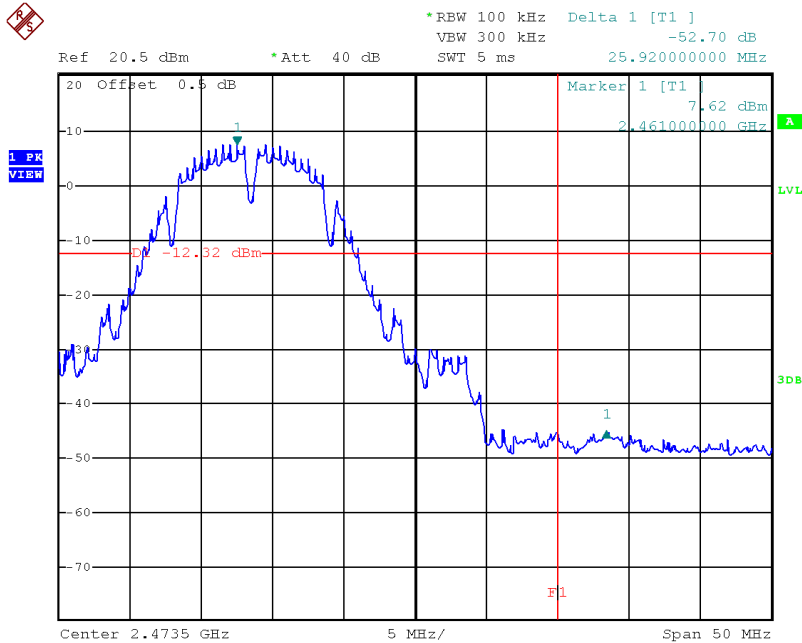

Date: 11.MAY.2017 05:59:18

INTERTEK TESTING SERVICES

Plots of Bandedge

802.11g, Lowest Channel

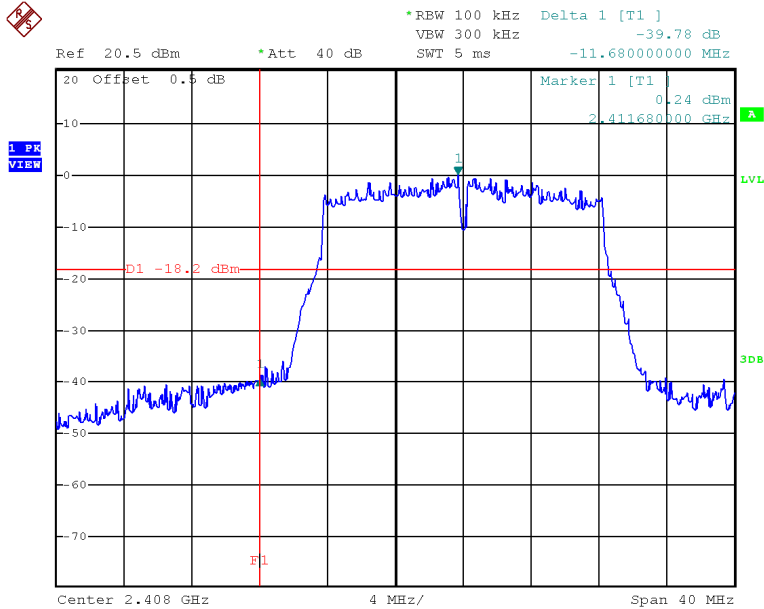

Date: 11.MAY.2017 06:34:30

802.11g, Highest Channel

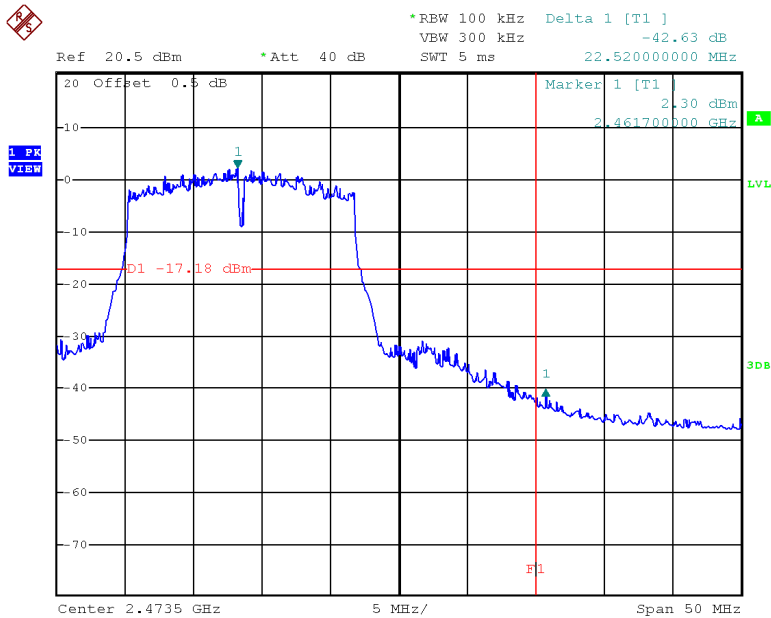

Date: 11.MAY.2017 05:56:02

INTERTEK TESTING SERVICES

Plots of Bandedge

802.11n (NT20), Lowest Channel

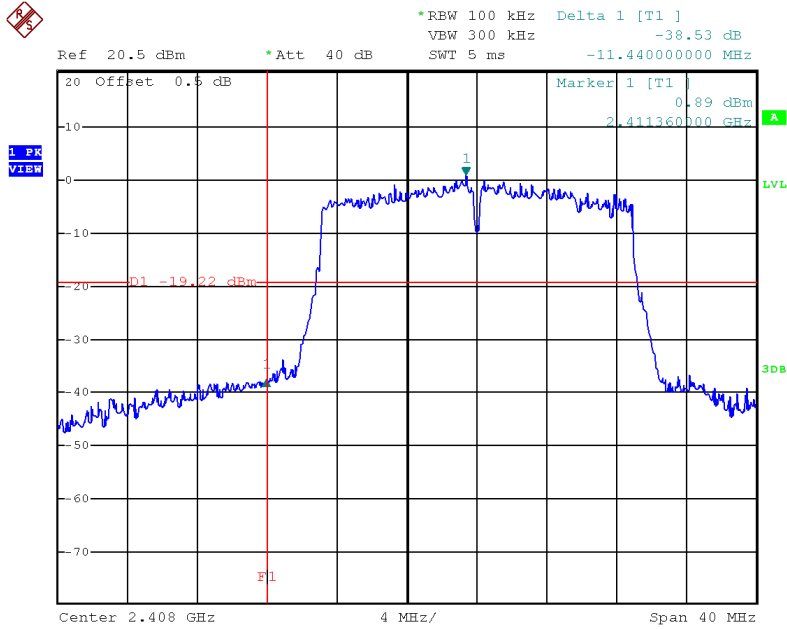

Date: 11.MAY.2017 08:49:09

802.11n (HT20), Highest Channel

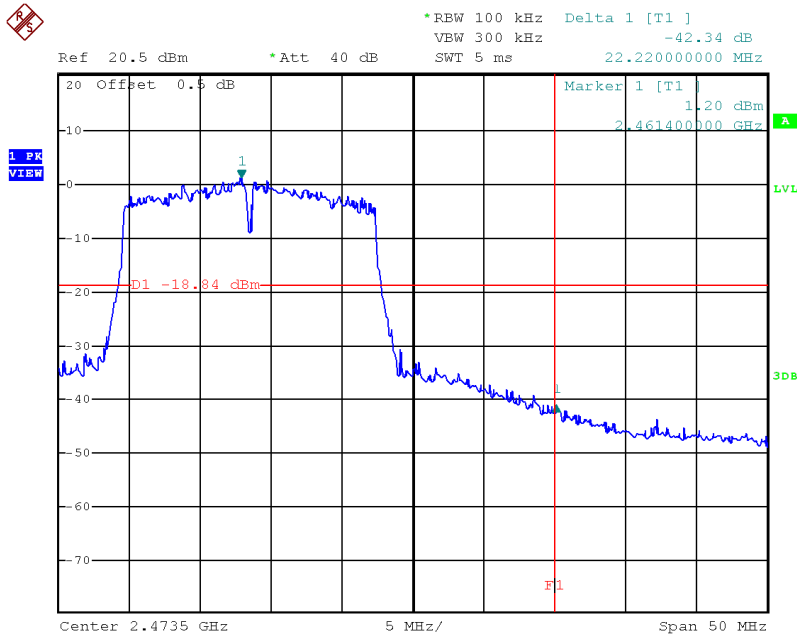

Date: 11.MAY.2017 05:54:39

INTERTEK TESTING SERVICES

Plots of Bandedge

802.11n (NT40), Lowest Channel

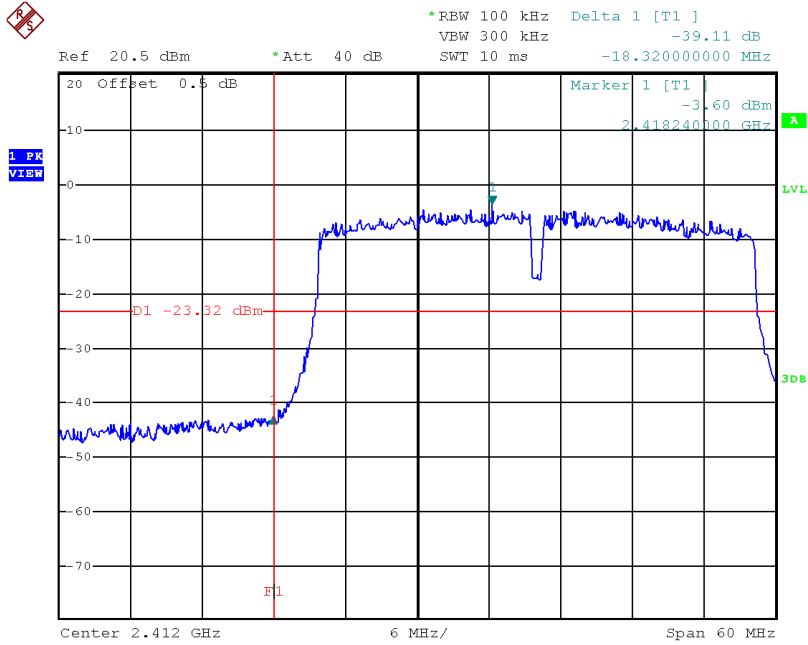

Date: 11.MAY.2017 09:15:34

802.11n (HT40), Highest Channel

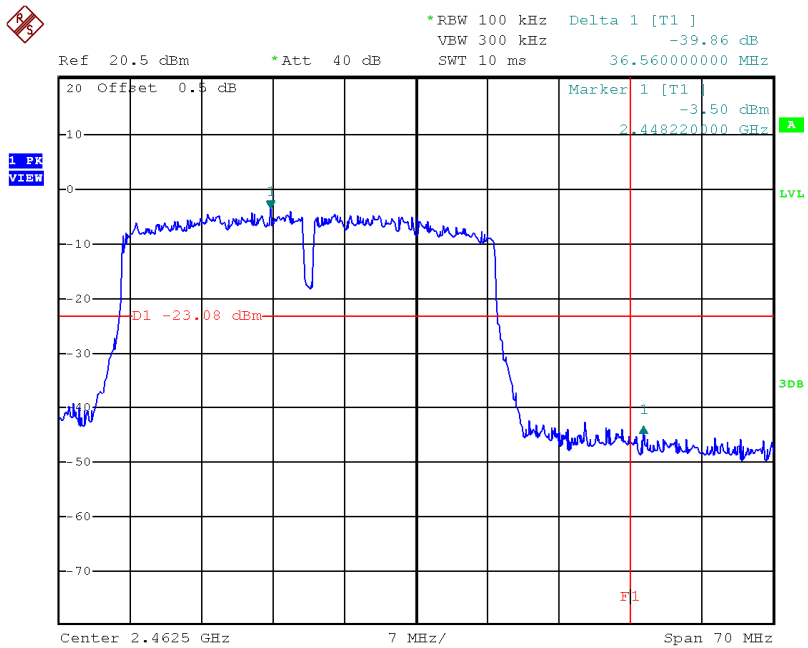

Date: 11.MAY.2017 09:41:34

INTERTEK TESTING SERVICES

4.5 Field Strength Calculation

The field strength is calculated by adding the reading on the Spectrum Analyzer to the factors associated with preamplifiers (if any), antennas, cables, pulse desensitization and average factors (when specified limit is in average and measurements are made with peak detectors). A sample calculation is included below.

$$FS = RA + AF + CF - AG + PD + AV$$

Where

- FS = Field Strength in dB μ V/m
- RA = Receiver Amplitude (including preamplifier) in dB μ V
- CF = Cable Attenuation Factor in dB
- AF = Antenna Factor in dB
- AG = Amplifier Gain in dB
- PD = Pulse Desensitization in dB
- AV = Average Factor in -dB

In the radiated emission table which follows, the reading shown on the data table may reflect the preamplifier gain. An example of the calculations, where the reading does not reflect the preamplifier gain, follows:

$$FS = RA + AF + CF - AG + PD + AV$$

Example

Assume a receiver reading of 62.0 dB μ V is obtained. The antenna factor of 7.4 dB and cable factor of 1.6 dB is added. The amplifier gain of 29.0 dB is subtracted. The pulse desensitization factor of the spectrum analyzer is 0.0 dB, and the resultant average factor is -10.0 dB. The net field strength for comparison to the appropriate emission limit is 32.0 dB μ V/m. This value in dB μ V/m is converted to its corresponding level in μ V/m.

RA = 62.0 dB μ V
AF = 7.4 dB
CF = 1.6 dB
AG = 29.0 dB
PD = 0.0 dB
AV = -10 dB

$$FS = 62.0 + 7.4 + 1.6 - 29.0 + 0.0 + (-10.0) = 32.0 \text{ dB}\mu\text{V/m}$$

$$\text{Level in } \mu\text{V/m} = \text{Common Antilogarithm} [(32.0 \text{ dB}\mu\text{V/m})/20] = 39.8 \mu\text{V/m}$$

INTERTEK TESTING SERVICES

4.6 Transmitter Radiated Emissions in Restricted Bands and Spurious Emissions

Data is included of the worst case configuration (the configuration which resulted in the highest emission levels). A sample calculation, configuration photographs and data tables of the emissions are included.

The data on the following pages list the significant emission frequencies, the limit and the margin of compliance.

4.6.1 Radiated Emission Configuration Photograph

Worst Case Restricted Band Radiated Emission
at

2483.500 MHz

The worst case radiated emission configuration photographs are saved with filename:
config photos.pdf

4.6.2 Radiated Emission Data

The data in tables 1-13 list the significant emission frequencies, the limit and the margin of compliance.

Judgement -

Passed by 0.6 dB margin

INTERTEK TESTING SERVICES

Mode: TX-Channel 01

Date of Test: May 22, 2017

Table 1
IEEE 802.11b (DSSS, 1 Mbps)

Radiated Emission Data

Polarization	Frequency (MHz)	Reading (dBUV)	Pre-Amp Gain (dB)	Antenna Factor (dB)	Net at 3m (dBUV/m)	Average Limit at 3m (dBUV/m)	Margin (dB)
V	2390.000	49.8	33	29.4	46.2	54.0	-7.8
V	4824.000	40.5	33	34.9	42.4	54.0	-11.6
V	12060.000	33.7	33	40.5	41.2	54.0	-12.8

Polarization	Frequency (MHz)	Reading (dBUV)	Pre-Amp Gain (dB)	Antenna Factor (dB)	Net at 3m - Peak (dBUV/m)	Peak Limit at 3m (dBUV/m)	Margin (dB)
V	2390.000	62.0	33	29.4	58.4	74.0	-15.6
V	4824.000	50.7	33	34.9	52.6	74.0	-21.4
V	12060.000	43.9	33	40.5	51.4	74.0	-22.6

- NOTES:
1. Peak detector is used for the peak emission measurement.
 2. Average measurement method is according to ANSI C63.10
 3. All measurements were made at 3 meters. Radiated emissions not detected at the 3-meter distance were measured at 0.3-meter and an inverse proportional extrapolation was performed to compare the signal level to the 3-meter limit. No other radiated emissions than those reported were detected at a test distance of 0.3-meter.
 4. Negative value in the margin column shows emission below limit.
 5. Horn antenna is used for the emission over 1000MHz.
 6. Emission (the row indicated by **bold italic**) within the restricted band meets the requirement of FCC Part 15 Section 15.205 / RSS-Gen 8.10.
 7. For the measurement of radiated emission, summation method was used which numerical integrating (in terms of linear power) over the transmitter occupied bandwidth.
 8. For the linear power measurement, data in 1MHz spacing was collected by spectrum analyzer with 1MHz resolution bandwidth.

INTERTEK TESTING SERVICES

Mode: TX-Channel 06

Date of Test: May 22, 2017

Table 2
IEEE 802.11b (DSSS, 1 Mbps)

Radiated Emission Data

Polarization	Frequency	Reading (dBuV)	Pre-Amp Gain (dB)	Antenna Factor (dB)	Net at 3m (dBuV/m)	Average Limit at 3m (dBuV/m)	Margin (dB)
V	4874.000	40.3	33	34.9	42.2	54.0	-11.8
V	7311.000	37.3	33	37.9	42.2	54.0	-11.8
V	12185.000	34.7	33	40.5	42.2	54.0	-11.8

Polarization	Frequency	Reading (dBuV)	Pre-Amp Gain (dB)	Antenna Factor (dB)	Net at 3m - Peak (dBuV/m)	Peak Limit at 3m (dBuV/m)	Margin (dB)
V	4874.000	50.7	33	34.9	52.6	74.0	-21.4
V	7311.000	47.6	33	37.9	52.5	74.0	-21.5
V	12185.000	44.1	33	40.5	51.6	74.0	-22.4

- NOTES:
1. Peak detector is used for the peak emission measurement.
 2. Average measurement method is according to ANSI C63.10
 3. All measurements were made at 3 meters. Radiated emissions not detected at the 3-meter distance were measured at 0.3-meter and an inverse proportional extrapolation was performed to compare the signal level to the 3-meter limit. No other radiated emissions than those reported were detected at a test distance of 0.3-meter.
 4. Negative value in the margin column shows emission below limit.
 5. Horn antenna is used for the emission over 1000MHz.
 6. Emission (the row indicated by **bold italic**) within the restricted band meets the requirement of FCC Part 15 Section 15.205 / RSS-Gen 8.10.
 7. For the measurement of radiated emission, summation method was used which numerical integrating (in terms of linear power) over the transmitter occupied bandwidth.
 8. For the linear power measurement, data in 1MHz spacing was collected by spectrum analyzer with 1MHz resolution bandwidth.

INTERTEK TESTING SERVICES

Mode: TX-Channel 11

Date of Test: May 22, 2017

Table 3
IEEE 802.11b (DSSS, 1 Mbps)

Radiated Emission Data

Polarization	Frequency	Reading (dBuV)	Pre-Amp Gain (dB)	Antenna Factor (dB)	Net at 3m (dBuV/m)	Average Limit at 3m (dBuV/m)	Margin (dB)
V	2483.500	52.0	33	29.4	48.4	54.0	-5.6
V	4924.000	40.5	33	34.9	42.4	54.0	-11.6
V	7386.000	37.3	33	37.9	42.2	54.0	-11.8
V	12310.000	33.9	33	40.5	41.4	54.0	-12.6

Polarization	Frequency	Reading (dBuV)	Pre-Amp Gain (dB)	Antenna Factor (dB)	Net at 3m - Peak (dBuV/m)	Peak Limit at 3m (dBuV/m)	Margin (dB)
V	2483.500	71.8	33	29.4	68.2	74.0	-5.8
V	4924.000	50.7	33	34.9	52.6	74.0	-21.4
V	7386.000	47.7	33	37.9	52.6	74.0	-21.4
V	12310.000	43.7	33	40.5	51.2	74.0	-22.8

- NOTES:
1. Peak detector is used for the peak emission measurement.
 2. Average measurement method is according to ANSI C63.10
 3. All measurements were made at 3 meters. Radiated emissions not detected at the 3-meter distance were measured at 0.3-meter and an inverse proportional extrapolation was performed to compare the signal level to the 3-meter limit. No other radiated emissions than those reported were detected at a test distance of 0.3-meter.
 4. Negative value in the margin column shows emission below limit.
 5. Horn antenna is used for the emission over 1000MHz.
 6. Emission (the row indicated by **bold italic**) within the restricted band meets the requirement of FCC Part 15 Section 15.205 / RSS-Gen 8.10.
 7. For the measurement of radiated emission, summation method was used which numerical integrating (in terms of linear power) over the transmitter occupied bandwidth.
 8. For the linear power measurement, data in 1MHz spacing was collected by spectrum analyzer with 1MHz resolution bandwidth.

INTERTEK TESTING SERVICES

Mode: TX-Channel 01

Date of Test: May 22, 2017

Table 4
IEEE 802.11g (OFDM, 6 Mbps)

Radiated Emission Data

Polarization	Frequency (MHz)	Reading (dBuV)	Pre-Amp Gain (dB)	Antenna Factor (dB)	Net at 3m (dBuV/m)	Average Limit at 3m (dBuV/m)	Margin (dB)
V	2390.000	52.0	33	29.4	48.4	54.0	-5.6
V	4824.000	40.5	33	34.9	42.4	54.0	-11.6
V	12060.000	33.8	33	40.5	41.3	54.0	-12.7

Polarization	Frequency (MHz)	Reading (dBuV)	Pre-Amp Gain (dB)	Antenna Factor (dB)	Net at 3m - Peak (dBuV/m)	Peak Limit at 3m (dBuV/m)	Margin (dB)
V	2390.000	67.1	33	29.4	63.5	74.0	-10.5
V	4824.000	50.9	33	34.9	52.8	74.0	-21.2
V	12060.000	43.7	33	40.5	51.2	74.0	-22.8

- NOTES:
1. Peak detector is used for the peak emission measurement.
 2. Average measurement method is according to ANSI C63.10
 3. All measurements were made at 3 meters. Radiated emissions not detected at the 3-meter distance were measured at 0.3-meter and an inverse proportional extrapolation was performed to compare the signal level to the 3-meter limit. No other radiated emissions than those reported were detected at a test distance of 0.3-meter.
 4. Negative value in the margin column shows emission below limit.
 5. Horn antenna is used for the emission over 1000MHz.
 6. Emission (the row indicated by **bold italic**) within the restricted band meets the requirement of FCC Part 15 Section 15.205 / RSS-Gen 8.10.
 7. For the measurement of radiated emission, summation method was used which numerical integrating (in terms of linear power) over the transmitter occupied bandwidth.
 8. For the linear power measurement, data in 1MHz spacing was collected by spectrum analyzer with 1MHz resolution bandwidth.

INTERTEK TESTING SERVICES

Mode: TX-Channel 06
Date of Test: May 22, 2017

Table 5
IEEE 802.11g (OFDM, 6 Mbps)

Radiated Emission Data

Polarization	Frequency	Reading (dBuV)	Pre-Amp Gain (dB)	Antenna Factor (dB)	Net at 3m (dBuV/m)	Average Limit at 3m (dBuV/m)	Margin (dB)
V	4874.000	40.5	33	34.9	42.4	54.0	-11.6
V	7311.000	37.7	33	37.9	42.6	54.0	-11.4
V	12185.000	33.7	33	40.5	41.2	54.0	-12.8

Polarization	Frequency	Reading (dBuV)	Pre-Amp Gain (dB)	Antenna Factor (dB)	Net at 3m - Peak (dBuV/m)	Peak Limit at 3m (dBuV/m)	Margin (dB)
V	4874.000	50.7	33	34.9	52.6	74.0	-21.4
V	7311.000	47.8	33	37.9	52.7	74.0	-21.3
V	12185.000	43.9	33	40.5	51.4	74.0	-22.6

- NOTES:
1. Peak detector is used for the peak emission measurement.
 2. Average measurement method is according to ANSI C63.10
 3. All measurements were made at 3 meters. Radiated emissions not detected at the 3-meter distance were measured at 0.3-meter and an inverse proportional extrapolation was performed to compare the signal level to the 3-meter limit. No other radiated emissions than those reported were detected at a test distance of 0.3-meter.
 4. Negative value in the margin column shows emission below limit.
 5. Horn antenna is used for the emission over 1000MHz.
 6. Emission (the row indicated by **bold italic**) within the restricted band meets the requirement of FCC Part 15 Section 15.205 / RSS-Gen 8.10.
 7. For the measurement of radiated emission, summation method was used which numerical integrating (in terms of linear power) over the transmitter occupied bandwidth.
 8. For the linear power measurement, data in 1MHz spacing was collected by spectrum analyzer with 1MHz resolution bandwidth.

INTERTEK TESTING SERVICES

Mode: TX-Channel 11
Date of Test: May 22, 2017

Table 6
IEEE 802.11g (OFDM, 6 Mbps)

Radiated Emission Data

Polarization	Frequency	Reading (dBuV)	Pre-Amp Gain (dB)	Antenna Factor (dB)	Net at 3m (dBuV/m)	Average Limit at 3m (dBuV/m)	Margin (dB)
V	<i>2483.500</i>	<i>56.8</i>	<i>33</i>	<i>29.4</i>	<i>53.2</i>	<i>54.0</i>	<i>-0.8</i>
V	<i>4924.000</i>	<i>40.5</i>	<i>33</i>	<i>34.9</i>	<i>42.4</i>	<i>54.0</i>	<i>-11.6</i>
V	<i>7386.000</i>	<i>37.5</i>	<i>33</i>	<i>37.9</i>	<i>42.4</i>	<i>54.0</i>	<i>-11.6</i>
V	<i>12310.000</i>	<i>33.7</i>	<i>33</i>	<i>40.5</i>	<i>41.2</i>	<i>54.0</i>	<i>-12.8</i>

Polarization	Frequency	Reading (dBuV)	Pre-Amp Gain (dB)	Antenna Factor (dB)	Net at 3m - Peak (dBuV/m)	Peak Limit at 3m (dBuV/m)	Margin (dB)
V	<i>2483.500</i>	<i>75.8</i>	<i>33</i>	<i>29.4</i>	<i>72.2</i>	<i>74.0</i>	<i>-1.8</i>
V	<i>4924.000</i>	<i>50.7</i>	<i>33</i>	<i>34.9</i>	<i>52.6</i>	<i>74.0</i>	<i>-21.4</i>
V	<i>7386.000</i>	<i>47.9</i>	<i>33</i>	<i>37.9</i>	<i>52.8</i>	<i>74.0</i>	<i>-21.2</i>
V	<i>12310.000</i>	<i>43.9</i>	<i>33</i>	<i>40.5</i>	<i>51.4</i>	<i>74.0</i>	<i>-22.6</i>

- NOTES:
1. Peak detector is used for the peak emission measurement.
 2. Average measurement method is according to ANSI C63.10
 3. All measurements were made at 3 meters. Radiated emissions not detected at the 3-meter distance were measured at 0.3-meter and an inverse proportional extrapolation was performed to compare the signal level to the 3-meter limit. No other radiated emissions than those reported were detected at a test distance of 0.3-meter.
 4. Negative value in the margin column shows emission below limit.
 5. Horn antenna is used for the emission over 1000MHz.
 6. Emission (the row indicated by ***bold italic***) within the restricted band meets the requirement of FCC Part 15 Section 15.205 / RSS-Gen 8.10.
 7. For the measurement of radiated emission, summation method was used which numerical integrating (in terms of linear power) over the transmitter occupied bandwidth.
 8. For the linear power measurement, data in 1MHz spacing was collected by spectrum analyzer with 1MHz resolution bandwidth.

INTERTEK TESTING SERVICES

Mode: TX-Channel 01
Date of Test: May 22, 2017

Table 7
IEEE 802.11n (HT20, MCS0)

Radiated Emission Data

Polarization	Frequency (MHz)	Reading (dBuV)	Pre-Amp Gain (dB)	Antenna Factor (dB)	Net at 3m (dBuV/m)	Average Limit at 3m (dBuV/m)	Margin (dB)
V	2390.000	52.0	33	29.4	48.4	54.0	-5.6
V	4824.000	40.2	33	34.9	42.1	54.0	-11.9
V	12060.000	33.7	33	40.5	41.2	54.0	-12.8

Polarization	Frequency (MHz)	Reading (dBuV)	Pre-Amp Gain (dB)	Antenna Factor (dB)	Net at 3m - Peak (dBuV/m)	Peak Limit at 3m (dBuV/m)	Margin (dB)
V	2390.000	68.0	33	29.4	64.4	74.0	-9.6
V	4824.000	50.7	33	34.9	52.6	74.0	-21.4
V	12060.000	43.7	33	40.5	51.2	74.0	-22.8

- NOTES:
1. Peak detector is used for the peak emission measurement.
 2. Average measurement method is according to ANSI C63.10
 3. All measurements were made at 3 meters. Radiated emissions not detected at the 3-meter distance were measured at 0.3-meter and an inverse proportional extrapolation was performed to compare the signal level to the 3-meter limit. No other radiated emissions than those reported were detected at a test distance of 0.3-meter.
 4. Negative value in the margin column shows emission below limit.
 5. Horn antenna is used for the emission over 1000MHz.
 6. Emission (the row indicated by **bold italic**) within the restricted band meets the requirement of FCC Part 15 Section 15.205 / RSS-Gen 8.10.
 7. For the measurement of radiated emission, summation method was used which numerical integrating (in terms of linear power) over the transmitter occupied bandwidth.
 8. For the linear power measurement, data in 1MHz spacing was collected by spectrum analyzer with 1MHz resolution bandwidth.

INTERTEK TESTING SERVICES

Mode: TX-Channel 06
Date of Test: May 22, 2017

Table 8
IEEE 802.11n (HT20, MCS0)

Radiated Emission Data

Polarization	Frequency	Reading (dBuV)	Pre-Amp Gain (dB)	Antenna Factor (dB)	Net at 3m (dBuV/m)	Average Limit at 3m (dBuV/m)	Margin (dB)
V	4874.000	40.5	33	34.9	42.4	54.0	-11.6
V	7311.000	37.3	33	37.9	42.2	54.0	-11.8
V	12185.000	33.7	33	40.5	41.2	54.0	-12.8

Polarization	Frequency	Reading (dBuV)	Pre-Amp Gain (dB)	Antenna Factor (dB)	Net at 3m - Peak (dBuV/m)	Peak Limit at 3m (dBuV/m)	Margin (dB)
V	4874.000	50.7	33	34.9	52.6	74.0	-21.4
V	7311.000	47.6	33	37.9	52.5	74.0	-21.5
V	12185.000	43.7	33	40.5	51.2	74.0	-22.8

- NOTES:
1. Peak detector is used for the peak emission measurement.
 2. Average measurement method is according to ANSI C63.10
 3. All measurements were made at 3 meters. Radiated emissions not detected at the 3-meter distance were measured at 0.3-meter and an inverse proportional extrapolation was performed to compare the signal level to the 3-meter limit. No other radiated emissions than those reported were detected at a test distance of 0.3-meter.
 4. Negative value in the margin column shows emission below limit.
 5. Horn antenna is used for the emission over 1000MHz.
 6. Emission (the row indicated by **bold italic**) within the restricted band meets the requirement of FCC Part 15 Section 15.205 / RSS-Gen 8.10.
 7. For the measurement of radiated emission, summation method was used which numerical integrating (in terms of linear power) over the transmitter occupied bandwidth.
 8. For the linear power measurement, data in 1MHz spacing was collected by spectrum analyzer with 1MHz resolution bandwidth.

INTERTEK TESTING SERVICES

Mode: TX-Channel 11
Date of Test: May 22, 2017

Table 9
IEEE 802.11n (HT20, MCS0)

Radiated Emission Data

Polarization	Frequency	Reading (dBuV)	Pre-Amp Gain (dB)	Antenna Factor (dB)	Net at 3m (dBuV/m)	Average Limit at 3m (dBuV/m)	Margin (dB)
V	2483.500	57.0	33	29.4	53.4	54.0	-0.6
V	4924.000	40.5	33	34.9	42.4	54.0	-11.6
V	7386.000	37.4	33	37.9	42.3	54.0	-11.7
V	12310.000	33.7	33	40.5	41.2	54.0	-12.8

Polarization	Frequency	Reading (dBuV)	Pre-Amp Gain (dB)	Antenna Factor (dB)	Net at 3m - Peak (dBuV/m)	Peak Limit at 3m (dBuV/m)	Margin (dB)
V	2483.500	75.8	33	29.4	72.2	74.0	-1.8
V	4924.000	50.4	33	34.9	52.3	74.0	-21.7
V	7386.000	47.7	33	37.9	52.6	74.0	-21.4
V	12310.000	43.8	33	40.5	51.3	74.0	-22.7

- NOTES:
1. Peak detector is used for the peak emission measurement.
 2. Average measurement method is according to ANSI C63.10
 3. All measurements were made at 3 meters. Radiated emissions not detected at the 3-meter distance were measured at 0.3-meter and an inverse proportional extrapolation was performed to compare the signal level to the 3-meter limit. No other radiated emissions than those reported were detected at a test distance of 0.3-meter.
 4. Negative value in the margin column shows emission below limit.
 5. Horn antenna is used for the emission over 1000MHz.
 6. Emission (the row indicated by **bold italic**) within the restricted band meets the requirement of FCC Part 15 Section 15.205 / RSS-Gen 8.10.
 7. For the measurement of radiated emission, summation method was used which numerical integrating (in terms of linear power) over the transmitter occupied bandwidth.
 8. For the linear power measurement, data in 1MHz spacing was collected by spectrum analyzer with 1MHz resolution bandwidth.

INTERTEK TESTING SERVICES

Mode: TX-Channel 03
Date of Test: May 22, 2017

Table 10
IEEE 802.11n (HT40, MCS0)

Radiated Emission Data

Polarization	Frequency (MHz)	Reading (dBuV)	Pre-Amp Gain (dB)	Antenna Factor (dB)	Net at 3m (dBuV/m)	Average Limit at 3m (dBuV/m)	Margin (dB)
V	2390.000	49.8	33	29.4	46.2	54.0	-7.8
V	4844.000	39.2	33	34.9	41.1	54.0	-12.9
V	12110.000	33.8	33	40.5	41.3	54.0	-12.7

Polarization	Frequency (MHz)	Reading (dBuV)	Pre-Amp Gain (dB)	Antenna Factor (dB)	Net at 3m - Peak (dBuV/m)	Peak Limit at 3m (dBuV/m)	Margin (dB)
V	2390.000	61.8	33	29.4	58.2	74.0	-15.8
V	4844.000	48.7	33	34.9	50.6	74.0	-23.4
V	12110.000	42.7	33	40.5	50.2	74.0	-23.8

- NOTES:
1. Peak detector is used for the peak emission measurement.
 2. Average measurement method is according to ANSI C63.10
 3. All measurements were made at 3 meters. Radiated emissions not detected at the 3-meter distance were measured at 0.3-meter and an inverse proportional extrapolation was performed to compare the signal level to the 3-meter limit. No other radiated emissions than those reported were detected at a test distance of 0.3-meter.
 4. Negative value in the margin column shows emission below limit.
 5. Horn antenna is used for the emission over 1000MHz.
 6. Emission (the row indicated by **bold italic**) within the restricted band meets the requirement of FCC Part 15 Section 15.205 / RSS-Gen 8.10.
 7. For the measurement of radiated emission, summation method was used which numerical integrating (in terms of linear power) over the transmitter occupied bandwidth.
 8. For the linear power measurement, data in 1MHz spacing was collected by spectrum analyzer with 1MHz resolution bandwidth.

INTERTEK TESTING SERVICES

Mode: TX-Channel 06
Date of Test: May 22, 2017

Table 11
IEEE 802.11n (HT40, MCS0)

Radiated Emission Data

Polarization	Frequency	Reading (dBuV)	Pre-Amp Gain (dB)	Antenna Factor (dB)	Net at 3m (dBuV/m)	Average Limit at 3m (dBuV/m)	Margin (dB)
V	4874.000	39.4	33	34.9	41.3	54.0	-12.7
V	7311.000	36.3	33	37.9	41.2	54.0	-12.8
V	12185.000	33.7	33	40.5	41.2	54.0	-12.8

Polarization	Frequency	Reading (dBuV)	Pre-Amp Gain (dB)	Antenna Factor (dB)	Net at 3m - Peak (dBuV/m)	Peak Limit at 3m (dBuV/m)	Margin (dB)
V	4874.000	48.7	33	34.9	50.6	74.0	-23.4
V	7311.000	45.6	33	37.9	50.5	74.0	-23.5
V	12185.000	42.7	33	40.5	50.2	74.0	-23.8

- NOTES:
1. Peak detector is used for the peak emission measurement.
 2. Average measurement method is according to ANSI C63.10
 3. All measurements were made at 3 meters. Radiated emissions not detected at the 3-meter distance were measured at 0.3-meter and an inverse proportional extrapolation was performed to compare the signal level to the 3-meter limit. No other radiated emissions than those reported were detected at a test distance of 0.3-meter.
 4. Negative value in the margin column shows emission below limit.
 5. Horn antenna is used for the emission over 1000MHz.
 6. Emission (the row indicated by **bold italic**) within the restricted band meets the requirement of FCC Part 15 Section 15.205 / RSS-Gen 8.10.
 7. For the measurement of radiated emission, summation method was used which numerical integrating (in terms of linear power) over the transmitter occupied bandwidth.
 8. For the linear power measurement, data in 1MHz spacing was collected by spectrum analyzer with 1MHz resolution bandwidth.

INTERTEK TESTING SERVICES

Mode: TX-Channel 09
Date of Test: May 22, 2017

Table 12
IEEE 802.11n (HT40, MCS0)

Radiated Emission Data

Polarization	Frequency	Reading (dBuV)	Pre-Amp Gain (dB)	Antenna Factor (dB)	Net at 3m (dBuV/m)	Average Limit at 3m (dBuV/m)	Margin (dB)
V	2483.500	56.4	33	29.4	52.8	54.0	-1.2
V	4904.000	39.5	33	34.9	41.4	54.0	-12.6
V	7356.000	36.5	33	37.9	41.4	54.0	-12.6
V	12260.000	33.7	33	40.5	41.2	54.0	-12.8

Polarization	Frequency	Reading (dBuV)	Pre-Amp Gain (dB)	Antenna Factor (dB)	Net at 3m - Peak (dBuV/m)	Peak Limit at 3m (dBuV/m)	Margin (dB)
V	2483.500	69.8	33	29.4	66.2	74.0	-7.8
V	4904.000	48.4	33	34.9	50.3	74.0	-23.7
V	7356.000	45.5	33	37.9	50.4	74.0	-23.6
V	12260.000	42.8	33	40.5	50.3	74.0	-23.7

- NOTES:
1. Peak detector is used for the peak emission measurement.
 2. Average measurement method is according to ANSI C63.10
 3. All measurements were made at 3 meters. Radiated emissions not detected at the 3-meter distance were measured at 0.3-meter and an inverse proportional extrapolation was performed to compare the signal level to the 3-meter limit. No other radiated emissions than those reported were detected at a test distance of 0.3-meter.
 4. Negative value in the margin column shows emission below limit.
 5. Horn antenna is used for the emission over 1000MHz.
 6. Emission (the row indicated by **bold italic**) within the restricted band meets the requirement of FCC Part 15 Section 15.205 / RSS-Gen 8.10.
 7. For the measurement of radiated emission, summation method was used which numerical integrating (in terms of linear power) over the transmitter occupied bandwidth.
 8. For the linear power measurement, data in 1MHz spacing was collected by spectrum analyzer with 1MHz resolution bandwidth.

INTERTEK TESTING SERVICES

Worst Case: EUT Simultaneous Transmitting (WiFi and Bluetooth) with charging
 Date of Test: May 22, 2017

Table 13

Radiated Emission Data

Polarization	Frequency (MHz)	Reading (dB μ V)	Pre-amp (dB)	Antenna Factor (dB)	Net at 3m (dB μ V/m)	Limit at 3m (dB μ V/m)	Margin (dB)
V	44.914	42.4	16	10.0	36.4	40.0	-3.6
V	67.224	44.2	16	8.0	36.2	40.0	-3.8
V	112.450	42.5	16	14.0	40.5	43.5	-3.0
V	157.434	36.2	16	16.0	36.2	43.5	-7.3
V	269.954	31.6	16	22.0	37.6	46.0	-8.4
V	314.938	32.2	16	23.0	39.2	46.0	-6.8
V	360.042	31.5	16	24.0	39.5	46.0	-6.5
V	405.026	34.8	16	24.0	42.8	46.0	-3.2
V	458.982	32.4	16	26.0	42.4	46.0	-3.6
V	584.962	29.8	16	28.0	41.8	46.0	-4.2
V	675.050	29.2	16	29.0	42.2	46.0	-3.8
V	800.058	27.6	16	31.0	42.6	46.0	-3.4

- NOTES:
1. Quasi-peak detector is used for the emission measurement.
 2. All measurements were made at 3 meters. Radiated emissions not detected at the 3-meter distance were measured at 0.3-meter and an inverse proportional extrapolation was performed to compare the signal level to the 3-meter limit. No other radiated emissions than those reported were detected at a test distance of 0.3-meter.
 3. Negative value in the margin column shows emission below limit.
 4. Emission (the row indicated by **bold italic**) within the restricted band meets the requirement of FCC Part 15 Section 15.205 / RSS-Gen 8.10.

INTERTEK TESTING SERVICES

Radiated Emission Test Setup

The figure below shows the test setup, which is utilized to make these measurements.

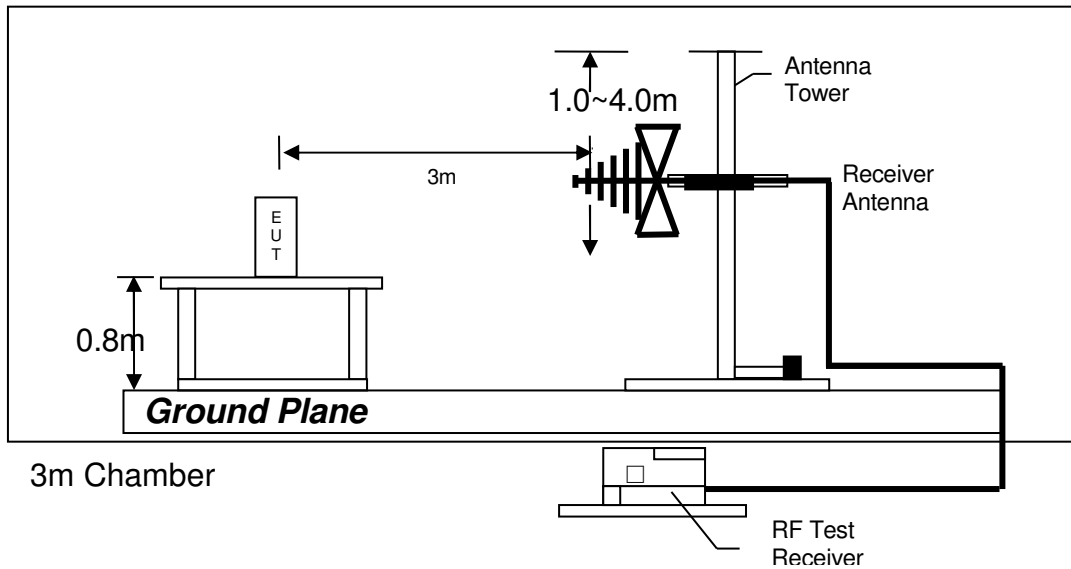

Test setup of radiated emissions up to 1GHz

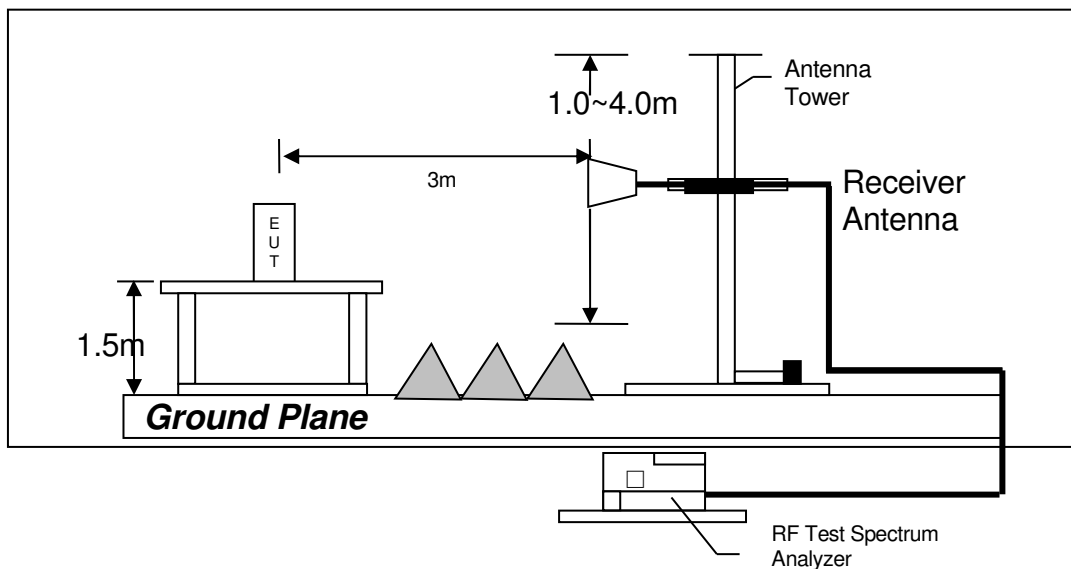

Test setup of radiated emissions above 1GHz

INTERTEK TESTING SERVICES

4.6.3 Transmitter Duty Cycle Calculation

Not applicable – No average factor is required.

4.7 AC Power Line Conducted Emission

- Not applicable – EUT is only powered by battery for operation.
- EUT connects to AC power line. Emission Data is listed in following pages.
- Base Unit connects to AC power line and has transmission. Handset connects to AC power line but has no transmission. Emission Data of Base Unit is listed in following pages.

4.7.1 AC Power Line Conducted Emission Configuration Photograph

Worst Case Line-Conducted Configuration
at

0.173 MHz

The worst case line conducted configuration photographs are attached in the Appendix and saved with filename: config photos.pdf

4.7.2 AC Power Line Conducted Emission Data

The plot(s) and data in the following pages list the significant emission frequencies, the limit and the margin of compliance

Passed by 3.8 dB

INTERTEK TESTING SERVICES

Worst Case: EUT Simultaneous Transmitting (WiFi and Bluetooth) with charging

EDIT PEAK LIST (Final Measurement Results)				
Trace1:	CF15MQP			
Trace2:	CF15MAV			
Trace3:	---			
TRACE	FREQUENCY	LEVEL dBμV		DELTA LIMIT dB
2 CISPR Average	154.5 kHz	45.48 L1		-10.27
1 Quasi Peak	172.5 kHz	61.05 N		-3.78
1 Quasi Peak	226.5 kHz	54.11 N		-8.45
2 CISPR Average	226.5 kHz	36.17 L1		-16.40
2 CISPR Average	307.5 kHz	28.70 N		-21.32
1 Quasi Peak	330 kHz	48.37 N		-11.08
2 CISPR Average	406.5 kHz	25.37 L1		-22.34
1 Quasi Peak	429 kHz	42.13 L1		-15.13
1 Quasi Peak	577.5 kHz	36.31 N		-19.68
1 Quasi Peak	870 kHz	30.51 L1		-25.48
1 Quasi Peak	1.4235 MHz	28.75 N		-27.24
1 Quasi Peak	1.725 MHz	29.62 N		-26.37

Date: 13.MAY.2017 23:13:28

INTERTEK TESTING SERVICES

Worst Case: EUT Simultaneous Transmitting (WiFi and Bluetooth) with charging

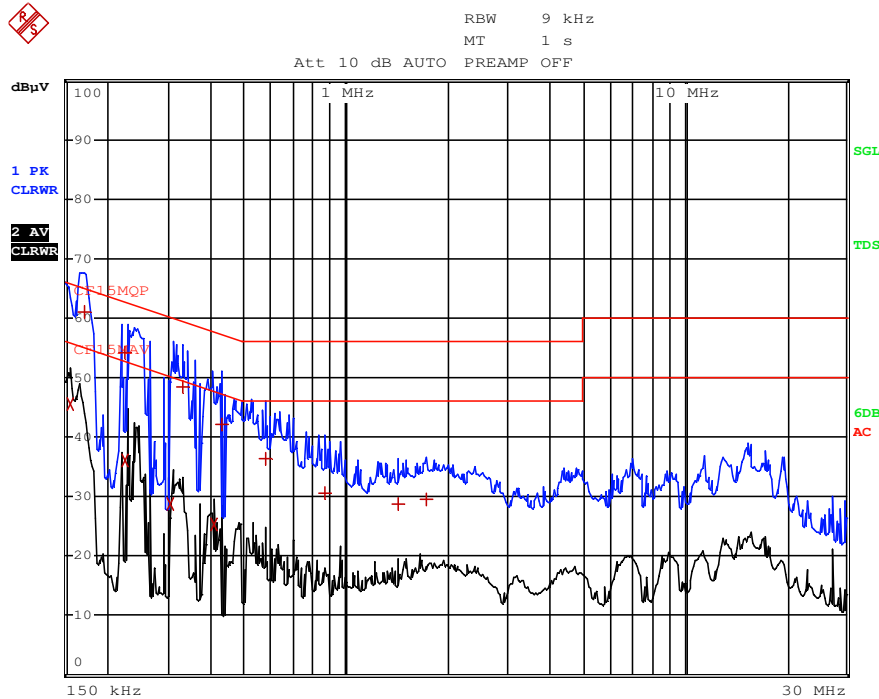

Date: 13.MAY.2017 23:13:50

Conducted Emission Test Setup

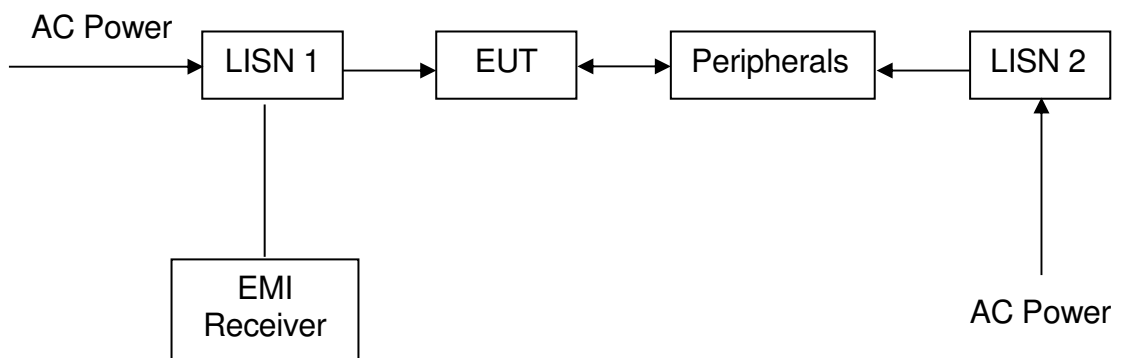

INTERTEK TESTING SERVICES

**EXHIBIT 5
EQUIPMENT LIST**

INTERTEK TESTING SERVICES

5.0 Equipment List

1) Radiated Emissions Test

Equipment	EMI Test Receiver	Spectrum Analyzer	Double Ridged Guide Antenna
Registration No.	EW-3156	EW-2253	EW-0194
Manufacturer	R&S	R&S	EMCO
Model No.	ESR26	FSP40	3115
Calibration Date	Dec. 06, 2016	Jun. 15, 2016	Aug. 10, 2016
Calibration Due Date	Dec. 06, 2017	Jun. 15, 2017	Feb. 10, 2018

Equipment	Biconical Antenna	Log Periodic Antenna	Pyramidal Horn Antenna
Registration No.	EW-0571	EW-0447	EW-0905
Manufacturer	EMCO	EMCO	EMCO
Model No.	3104C	3146	3160-09
Calibration Date	May 18, 2016	May 18, 2016	Feb. 12, 2016
Calibration Due Date	Nov. 18, 2017	Nov. 18, 2017	Aug. 12, 2017

2) Conductive Measurement Test

Equipment	Spectrum Analyzer	RF Power Meter	Power Sensor
Registration No.	EW-2253	SZ182-02	SZ182-02-01
Manufacturer	R&S	ANRITSU	ANRITSU
Model No.	FSP40	ML2496A	MA2411B
Calibration Date	Jun. 15, 2016	May. 23, 2016	May. 23, 2016
Calibration Due Date	Jun. 15, 2017	May. 23, 2017	May. 23, 2017

3) Conducted Emissions Test

Equipment	EMI Test Receiver	LISN	LISN
Registration No.	EW-2500	EW-2501	EW-2874
Manufacturer	R&S	R&S	R&S
Model No.	ESCI	ENV-216	ENV-216
Calibration Date	Nov. 17, 2016	Feb. 21, 2017	Mar. 16, 2017
Calibration Due Date	Nov. 17, 2017	Jan. 05, 2018	Mar. 16, 2018

END OF TEST REPORT