



RADIO TEST REPORT

Test Report No.: 31EE0162-SH-05-A
Original test report: 30HE0190-YK-01-A-R1

Applicant : **Alpine Electronics, Inc.**
Type of Equipment : **Bluetooth Module**
Model No. : **IAM2.1 BT PWB US4**
FCC ID : **A269ZUA135**
Test regulation : **FCC Part15 Subpart C: 2010**
(Class II change)
Test result : **Complied**

1. This test report shall not be reproduced in full or partial, without the written approval of UL Japan, Inc.
2. The results in this report apply only to the sample tested.
3. This sample tested is in compliance with the limits of the above regulation.
4. The test results in this test report are traceable to the national or international standards.
5. This test report must not be used by the customer to claim product certification, approval, or endorsement by any agency of the Federal Government.
6. The opinions and the interpretations to the result of the description in this report are outside scopes where UL Japan has been accredited.

Date of test: June 5 and 6, 2011

Representative test engineer:

Tatsuya Arai
Engineer of WiSE Japan,
UL Verification Service

Approved by :

Go Ishiwata
Manager of WiSE Japan,
UL Verification Service

- The testing in which "Non-accreditation" is displayed is outside the accreditation scopes in UL Japan.
 There is no testing item of "Non-accreditation".



UL Japan, Inc.
Shonan EMC Lab.

1-22-3 Megumigaoka, Hiratsuka-shi, Kanagawa-ken, 259-1220 JAPAN
Telephone : +81 463 50 6400
Facsimile : +81 463 50 6401

13-EM-F0429

Contents

	<u>Page</u>
SECTION 1: Customer information	3
SECTION 2: Equipment under test (E.U.T.).....	3
SECTION 3: Test specification, procedures & results	5
SECTION 4: Operation of E.U.T. during testing.....	7
SECTION 5: Radiated emission	9
Contents of appendixes	12
APPENDIX 1: Photographs of test setup	13
APPENDIX 2: Test data	15
APPENDIX 3: Test instruments	23

UL Japan, Inc.

Shonan EMC Lab.

1-22-3 Megumigaoka, Hiratsuka-shi, Kanagawa-ken, 259-1220 JAPAN

Telephone : +81 463 50 6400

Facsimile : +81 463 50 6401

SECTION 1: Customer information

Company Name : Alpine Electronics, Inc.
Address : 20-1 Yoshima kogyo-danchi, Iwaki-shi, Fukushima, 970-1192 Japan
Telephone Number : +81-246-36-4111
Facsimile Number : +81-246-36-6090
Contact Person : Isamu Takaku

SECTION 2: Equipment under test (E.U.T.)**2.1 Identification of E.U.T.**

Type of Equipment : Bluetooth Module
Model Number : IAM2.1 BT PWB US4
Serial Number : 2
Rating : DC9-16V
Country of Mass-production : Japan
Condition of EUT : Production prototype
(Not for Sale: This sample is equivalent to mass-produced items.)
Receipt Date of Sample : May 31, 2011
Modification of EUT : No modification by the test lab.

2.2 Product description

Model: IAM2.1 BT PWB US4 (referred to as the EUT in this report) is a Bluetooth Module.

Equipment type : Transceiver
Frequency of operation : 2402-2480MHz
Bandwidth & channel spacing : 79MHz & 1MHz
Type of modulation : FHSS (GFSK, $\pi/4$ DQPSK, 8DPSK)
Antenna type : Inverted-F
Antenna gain with cable loss : 0.7dBi
Antenna connector type : U.FL
ITU code : F1D, G1D
Operation temperature range : -30 to +85 deg.C.

UL Japan, Inc.**Shonan EMC Lab.**

1-22-3 Megumigaoka, Hiratsuka-shi, Kanagawa-ken, 259-1220 JAPAN

Telephone : +81 463 50 6400

Facsimile : +81 463 50 6401

Clock frequency list

Signal source description	Frequency
Main Microprocessor	24.000 MHz
	192 MHz
	96 MHz
	48 MHz
SUB Microprocessor	24.576 MHz
	49.152 MHz
	491.52 MHz
	122.88 MHz
APPLE DRM	32.768 kHz
AUDIO DSP	16.9344 MHz
	84.672 MHz
	120 MHz
	6.144 MHz
MAIN TUNER	20.8 MHz
SUB TUNER	20.8 MHz
HD RADIO (US Only)	28.22 MHz
Bluetooth	25.8048 MHz
	67.7376 MHz
	73.728 MHz
DC/DC Converter (PWM)	375 kHz
	385 kHz

Signal source description	Frequency
I ² C Bus	80 kHz
	400 kHz
DDR BUS	96.00 MHz
SD RAM	100.0 MHz
EXT BUS	96.00 MHz
	124.75 MHz
	17.64 MHz
MOST	49.152 MHz
Media Local BUS (MLB)	24.576 MHz
UART	921 kHz
USB2.0	240 MHz
IS BUS	38.4kHz
SPI BUS	1 MHz
Tuner IF	300 kHz
EPF-III BUS	1 MHz
I ² S Bus	3.072 MHz
	24.576MHz
	1.024 MHz

FCC Part15.31 (e)

This module provides the Bluetooth part with regulated power supply (DC3.3V and DC1.5V). Therefore, the equipment complies with power supply regulation.

FCC Part15.203 Antenna requirement

The EUT has a unique coupling/antenna connector; therefore, the equipment complies with the requirement of 15.203.

UL Japan, Inc.**Shonan EMC Lab.**

1-22-3 Megumigaoka, Hiratsuka-shi, Kanagawa-ken, 259-1220 JAPAN

Telephone : +81 463 50 6400

Facsimile : +81 463 50 6401

SECTION 3: Test specification, procedures & results

3.1 Test specification

Test specification : FCC Part 15 Subpart C: 2010, final revised on December 6, 2010 and effective January 5, 2011
Title : FCC 47CFR Part15 Radio Frequency Device Subpart C Intentional Radiators
Section 15.207 Conducted limits
Section 15.209 Radiated emission limits, general requirements
Section 15.247 Operation within the bands 902-928MHz, 2400-2483.5MHz, and 5725-5850MHz

The EUT complies with FCC Part 15 Subpart B: 2010. The test has been performed by the customer.

3.2 Procedures & Results

Item	Test Procedure	Specification	Remarks	Deviation	Worst Margin	Results
Conducted emission	ANSI C63.4:2003 7. AC powerline conducted emission measurements	FCC Section 15.207	-	N/A *1)	N/A	N/A
Carrier frequency separation	FCC Public Notice DA 00-705 & ANSI C63.4:2003 13. Measurement of intentional radiators	FCC Section15.247 (a)(1)	Conducted	*2)		N/A
20dB bandwidth	FCC Public Notice DA 00-705 & ANSI C63.4:2003 13. Measurement of intentional radiators	FCC Section15.247 (a)(1)	Conducted	*2)		N/A
Number of hopping frequency	FCC Public Notice DA 00-705 & ANSI C63.4:2003 13. Measurement of intentional radiators	FCC Section15.247 (a)(1)(iii)	Conducted	*2)		N/A
Dwell time	FCC Public Notice DA 00-705 & ANSI C63.4:2003 13. Measurement of intentional radiators	FCC Section15.247 (a)(1)(iii)	Conducted	*2)		N/A
Maximum peak output power	FCC Public Notice DA 00-705 & ANSI C63.4:2003 13. Measurement of intentional radiators	FCC Section15.247 (b)(1)	Conducted	*2)		N/A
Band edge compliance & Spurious emission	FCC Public Notice DA 00-705 & ANSI C63.4:2003 13. Measurement of intentional radiators	FCC Section15.247 (d) Section15.209	Conducted/ Radiated	N/A	0.8dB Freq.: 395.142MHz Detector: Quasi-Peak Polarization: Horizontal Mode: Tx 2402MHz, 3DH5	Complied *3)
Note: UL Japan's Work Procedures No. 13-EM-W0420 and 13-EM-W0422 *1) The test is not applicable since the EUT has no AC mains. *2) Refer to the original test report: 30HE0190-YK-01-A-R1. *3) No spurious noise was detected at the frequency range of 9kHz to 30MHz.						

3.3 Addition to standard

Other than above, no addition, exclusion nor deviation has been made from the standard.

UL Japan, Inc.

Shonan EMC Lab.

1-22-3 Megumigaoka, Hiratsuka-shi, Kanagawa-ken, 259-1220 JAPAN

Telephone : +81 463 50 6400

Facsimile : +81 463 50 6401

3.4 Uncertainty

The following uncertainties have been calculated to provide a confidence level of 95% using a coverage factor k=2.

Item	Frequency range	No.1 SAC*1/SR*2 (±)	No.2 SAC/SR (±)	No.3 SAC/SR (±)
Radiated emission (Measurement distance: 3m)	9kHz-30MHz	3.3 dB	2.7 dB	3.4 dB
	30MHz-300MHz	4.7 dB	4.5 dB	4.7 dB
	300MHz-1GHz	4.5 dB	4.6 dB	4.6 dB
	1GHz-18GHz	3.9 dB	3.9 dB	4.0 dB
	18GHz-26.5GHz	4.4 dB	4.4 dB	4.4 dB
Radiated emission (Measurement distance: 1m)	1GHz-18GHz	4.8 dB	4.8 dB	4.8 dB
	18GHz-40GHz	4.4 dB	4.2 dB	4.2 dB

*1: SAC=Semi-Anechoic Chamber

*2: SR= Shielded Room is applied besides radiated emission

The data listed in this report meets the limits unless the uncertainty is taken into consideration.

3.5 Test location

UL Japan, Inc. Shonan EMC Lab.

1-22-3, Megumigaoka, Hiratsuka-shi, Kanagawa-ken 259-1220 JAPAN

Telephone number : +81 463 50 6400

Facsimile number : +81 463 50 6401

JAB Accreditation No. : RTL02610

	FCC Registration No.	IC Registration No.	Width x Depth x Height (m)	Size of reference ground plane (m) / horizontal conducting plane	Maximum measurement distance
<input checked="" type="checkbox"/> No.1 Semi-anechoic chamber	697847	2973D-1	20.6 x 11.3 x 7.65	20.6 x 11.3	10m
<input type="checkbox"/> No.2 Semi-anechoic chamber	697847	2973D-2	20.6 x 11.3 x 7.65	20.6 x 11.3	10m
<input type="checkbox"/> No.3 Semi-anechoic chamber	697847	2973D-3	12.7 x 7.7 x 5.35	12.7 x 7.7	5m
<input type="checkbox"/> No.4 Full-anechoic chamber	-	-	8.1 x 5.1 x 3.55	8.1 x 5.1	-
<input type="checkbox"/> No.1 shielded room	-	-	6.8 x 4.1 x 2.7	6.8 x 4.1	-
<input type="checkbox"/> No.2 shielded room	-	-	6.8 x 4.1 x 2.7	6.8 x 4.1	-
<input type="checkbox"/> No.3 shielded room	-	-	6.3 x 4.7 x 2.7	6.3 x 4.7	-
<input type="checkbox"/> No.4 shielded room	-	-	4.4 x 4.7 x 2.7	4.4 x 4.7	-
<input type="checkbox"/> No.5 shielded room	-	-	7.8 x 6.4 x 2.7	7.8 x 6.4	-
<input type="checkbox"/> No.6 shielded room	-	-	7.8 x 6.4 x 2.7	7.8 x 6.4	-

3.6 Test setup, Data of test & Test instruments

Refer to Appendix 1 to 3.

UL Japan, Inc.

Shonan EMC Lab.

1-22-3 Megumigaoka, Hiratsuka-shi, Kanagawa-ken, 259-1220 JAPAN

Telephone : +81 463 50 6400

Facsimile : +81 463 50 6401

SECTION 4: Operation of E.U.T. during testing

4.1 Operating mode

The EUT exercise program used during testing was designed to exercise the various system components in a manner similar to typical use.

Test item	Operating mode	Tested frequency
Band edge compliance & Spurious emission	Transmitting (DH5/3DH5), Payload: PRBS9	Band edge compliance: 2402MHz, 2480MHz Spurious emission: 2402MHz, 2441MHz, 2480MHz

Justification: The system was configured in typical fashion (as customer would normally use it) for testing.

Software: ComAgent ver. 1.0.0.2, Youpet Japan (Interpets)

Setting:

BaudRate 9600
DataBits 8bit
StopBit 1.0bit
Parity None
FlowControl None

Power settings: Fixed (The setting is not controlled by the software and it is equivalent to that of mass-produced items.)

One mode was selected using the pull-down menu in the following operation modes. (Worst duty setting)

Mode	TX/RX	Freq. [MHz]		Hopping	Packet Type
Transmitting	TX	L	2402	OFF	DH5
			3DH5		
		M	2441	OFF	DH5
			3DH5		
		H	2480	OFF	DH5
			3DH5		

UL Japan, Inc.

Shonan EMC Lab.

1-22-3 Megumigaoka, Hiratsuka-shi, Kanagawa-ken, 259-1220 JAPAN

Telephone : +81 463 50 6400

Facsimile : +81 463 50 6401

4.2 Configuration and peripherals

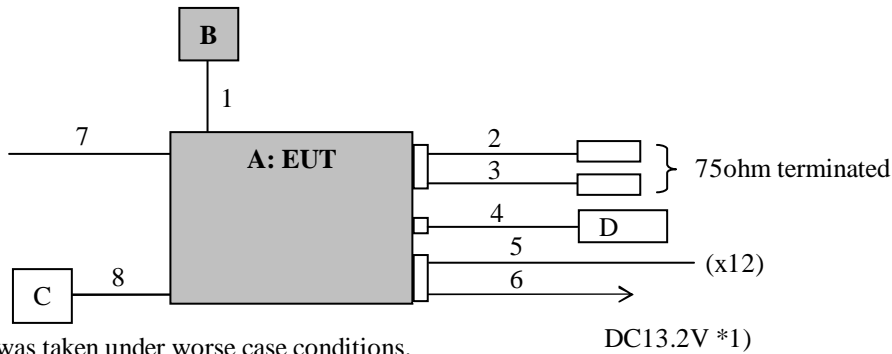

* Test data was taken under worse case conditions.

Description of EUT and support equipment

No.	Item	Model number	Serial number	Manufacturer	Remarks
A	Bluetooth Module	IAM2.1 BT PWB US4	2	ALPINE	EUT
B	Antenna	-	-	ALPINE	EUT
C	Fan	ASB0412MA	-	DELTA ELECTRONICS	-
D	USB flash memory	USM4GL-W	-	Sony	-

*1) DC power supply (Model No.: PAN35-10A) was used for DC 13.2V input.

List of cables used

No.	Name	Length (m)	Shield		Remark
			Cable	Connector	
1	Antenna cable	0.12	Shielded	Shielded	-
2	BNC cable	0.2	Shielded	Shielded	-
3	BNC cable	0.2	Shielded	Shielded	-
4	USB cable	0.15	Shielded	Shielded	-
5	Signal cable	0.9	Unshielded	Unshielded	(x12)
6	DC cable (+, -)	1.7	Unshielded	Unshielded	(x2)
7	Flexible cable	0.12	Unshielded	Unshielded	-
8	Fan cable	0.03	Unshielded	Unshielded	-

UL Japan, Inc.

Shonan EMC Lab.

1-22-3 Megumigaoka, Hiratsuka-shi, Kanagawa-ken, 259-1220 JAPAN

Telephone : +81 463 50 6400

Facsimile : +81 463 50 6401

SECTION 5: Radiated emission

5.1 Operating environment

The test was carried out in No.1 Semi-Anechoic Chamber.

Temperature : See test data (APPENDIX 2)

Humidity : See test data (APPENDIX 2)

5.2 Test configuration

EUT was placed on a platform of nominal size, 1m by 1.5m, raised 80cm above the conducting ground plane.

The table is made of Styrofoam and covered with polyvinyl chloride. That has very low permittivity.

The rear of EUT, including its peripherals was aligned and flushed with rear of tabletop. I/O cables were folded back and for the forming a bundle 30cm to 40cm long and were hanged at a 40cm height to the ground plane.

Test was made with the antenna positioned in both the horizontal and vertical planes of polarization. The measurement antenna was varied in height above the conducting ground plane to obtain the maximum signal strength.

Photographs of the set up are shown in Appendix 1.

5.3 Test conditions

Frequency range : 9kHz to 26GHz

Test distance : 3m (below 13GHz) / 1m (above 13GHz)

EUT position : Table top

5.4 Test procedure

The Radiated Electric Field Strength intensity has been measured on a semi-anechoic chamber with a ground plane and at a distance of 3m(below 13GHz) / 1m(above 13GHz) (Refer to Figure 1).

Frequency: From 9kHz to 30MHz at distance 3m

The EUT was rotated a full revolution in order to obtain the maximum value of the electric field intensity.

The measurements were performed for vertical polarization (antenna angle: 0deg., 45deg., 90deg., and 135 deg.) and horizontal polarization. Drawing of the antenna direction is shown in Figure 1.

Frequency: From 30MHz to 26GHz at distance 3m(below 13GHz) / 1m(above 13GHz)

The measuring antenna height was varied between 1 and 4m and EUT was rotated a full revolution in order to obtain the maximum value of the electric field intensity.

The measurements were performed for both vertical and horizontal antenna polarization.

Measurements were performed with quasi-peak, peak and average detector.

The radiated emission measurements were made with the following detection of the test receiver.

<9kHz to 30MHz>

	9kHz to 90kHz & 110kHz to 150kHz	90kHz to 110kHz	150kHz to 490kHz	490kHz to 30MHz
Detector Type	PK/AV	QP	PK/AV	QP
IF Bandwidth	200Hz	200Hz	10kHz	9kHz
Measuring antenna	Loop antenna			

* FCC Part 15 Section 15.31 (f)(2) (9kHz-30MHz)

9kHz – 490kHz [Limit at 3m]= [Limit at 300m]-40log (3[m]/300[m])

490kHz – 30MHz [Limit at 3m]= [Limit at 30m]-40log (3[m]/30[m])

UL Japan, Inc.

Shonan EMC Lab.

1-22-3 Megumigaoka, Hiratsuka-shi, Kanagawa-ken, 259-1220 JAPAN

Telephone : +81 463 50 6400

Facsimile : +81 463 50 6401

<30MHz to 26GHz>

Frequency	30MHz to 1GHz	Above 1GHz
Instrument used	Test Receiver	Spectrum Analyzer
Detector IF bandwidth	QP: BW 120kHz	PK: RBW: 1MHz VBW: 3MHz, AV: RBW: 1MHz *1) VBW: See data.

- *1) When using Spectrum analyzer, the test was made with adjusting span to zero by using peak hold.
*2) The VBW is based on the inverse of the duty cycle (Refer to the data).

The carrier level and noise levels were confirmed at each position of X, Y and Z axes of EUT and its antenna to see the position of maximum noise, and the test was made at the position that has the maximum noise.

Combinations of the worst case

Frequency	Worst position	
	Module	Antenna
Below 1GHz	Horizontal: X, Vertical: X	Horizontal: X, Vertical: X
Above 1GHz	Horizontal: Z, Vertical: Z	Horizontal: X, Vertical: Y

Figure 1. Antenna angle

Direction of the Loop Antenna

Side View (Vertical)

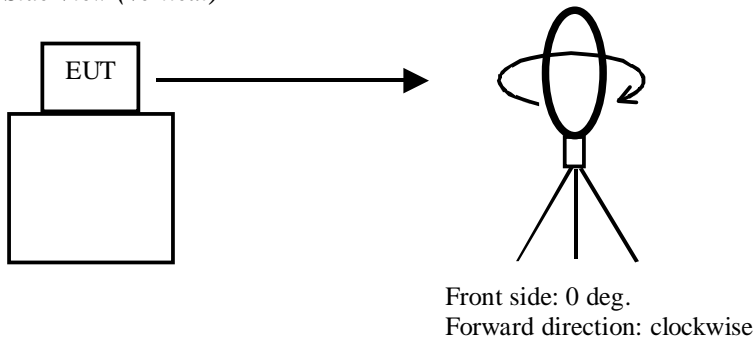

Top View (Vertical)

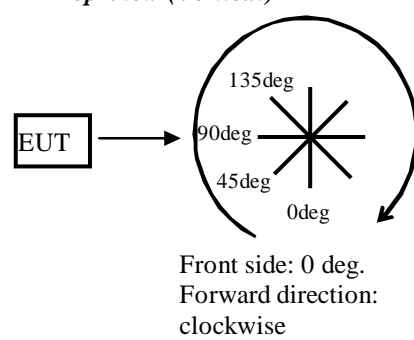

Top View (Horizontal)

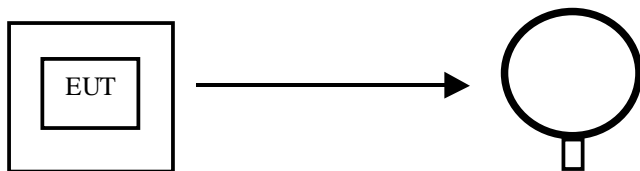

Antenna was not rotated.

UL Japan, Inc.

Shonan EMC Lab.

1-22-3 Megumigaoka, Hiratsuka-shi, Kanagawa-ken, 259-1220 JAPAN

Telephone : +81 463 50 6400

Facsimile : +81 463 50 6401

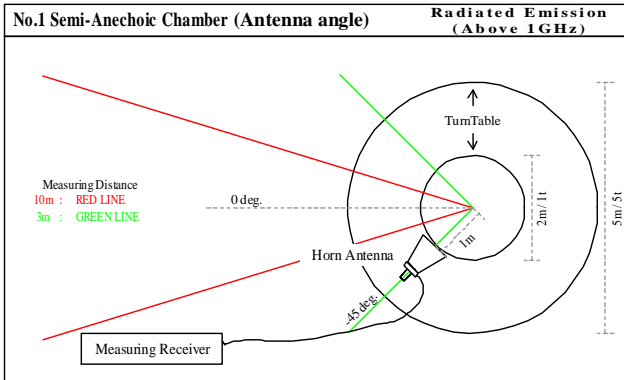
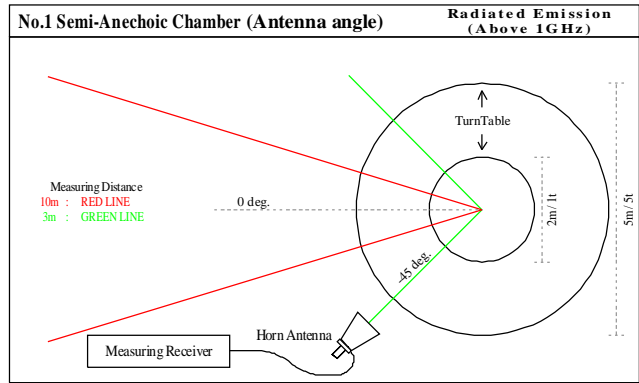
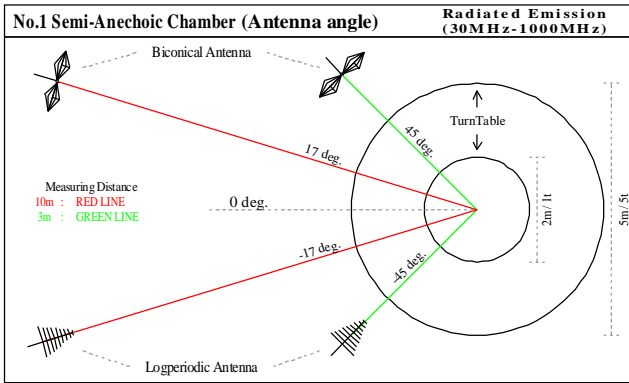

5.5 Band edge

Band edge level at 2390MHz, 2400MHz and 2483.5MHz is below the limits of FCC 15.209. Refer to the data.

5.6 Results

Summary of the test results : Pass *No noise was detected above the 5th order harmonics.

Refer to APPENDIX 2

UL Japan, Inc.

Shonan EMC Lab.

1-22-3 Megumigaoka, Hiratsuka-shi, Kanagawa-ken, 259-1220 JAPAN

Telephone : +81 463 50 6400

Facsimile : +81 463 50 6401

Contents of appendixes

APPENDIX 1: Photographs of test setup

Radiated emission
Pre-check of the worst position

APPENDIX 2: Test data

Radiated emission

APPENDIX 3: Test instruments

Test instruments

UL Japan, Inc.

Shonan EMC Lab.

1-22-3 Megumigaoka, Hiratsuka-shi, Kanagawa-ken, 259-1220 JAPAN

Telephone : +81 463 50 6400

Facsimile : +81 463 50 6401