

# OPERATION INSTRUCTION

**MODEL:**  
FA0198A  
FA0198A-D

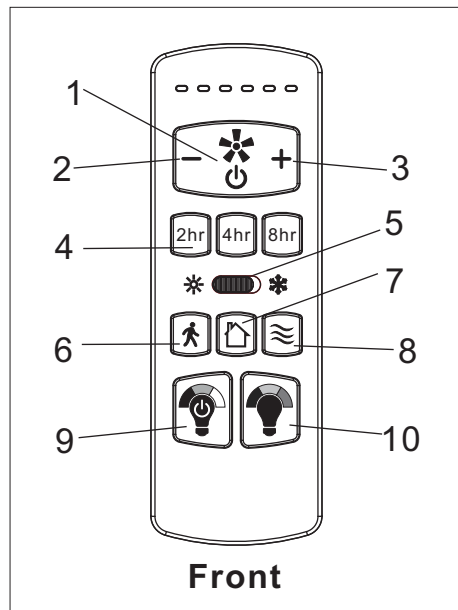

**Note:**  
Install two AAA 1.5V batteries to the remote control.

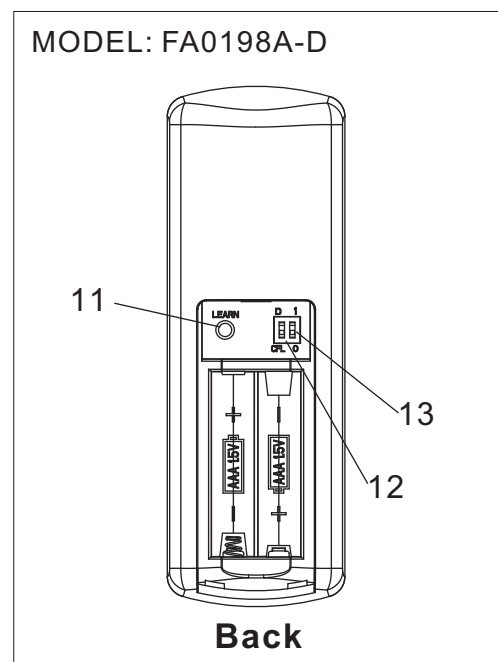
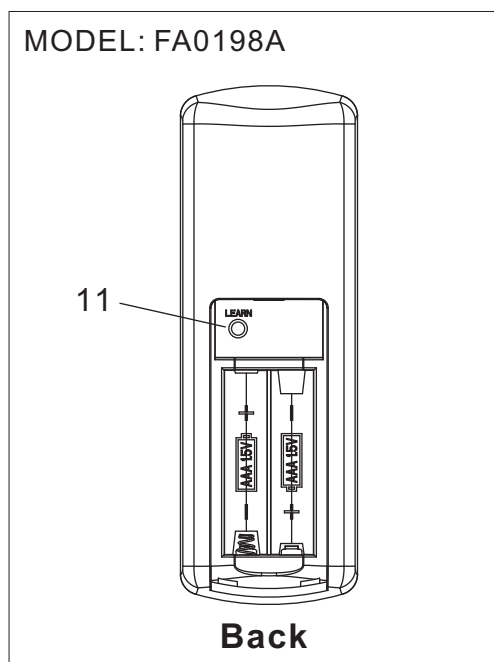

## **Remote Control Functions:**

1. FAN ON/OFF Button: Turn the fan on or off.
2. FAN Speed Button “-”: Decreases the fan speed.
3. FAN Speed Button “+”: Increases the fan speed.
4. 2hr/ 4hr/ 8hr Timer button.
5. Reverse Setting Switch: To control fan direction.
6. Walk Away Delay Off Button.
7. Home Shield Button.
8. Nature Breeze Button.
9. LIGHT ON/OFF/DIMMING Button: To control light on/off/dimming.
10. CCT Function Button.
11. Extended Function Switch L.

## **Remote Control Functions:**

1. FAN ON/OFF Button: Turn the fan on or off.
2. FAN Speed Button “-”: Decreases the fan speed.
3. FAN Speed Button “+”: Increases the fan speed.
4. 2hr/ 4hr/ 8hr Timer button.
5. Reverse Setting Switch: To control fan direction.
6. Walk Away Delay Off Button.
7. Home Shield Button.
8. Nature Breeze Button.
9. LIGHT ON/OFF/DIMMING Button: To control light on/off/dimming.
10. CCT Function Button.
11. Extended Function Switch L.
12. Extended Function Switch R.
13. Extended Function Switch C.

# OPERATION INSTRUCTION

---

This device has been tested and found to comply with the limits for a Class B digital device, pursuant to Part 15 of the FCC Rules. These limits are designed to provide reasonable protection against harmful interference in a residential installation. This device generates, uses and can radiate radio frequency energy and, if not installed and used in accordance with the instructions, may cause harmful interference to radio communications.

However, there is no guarantee that interference will not occur in a particular installation. If this device does cause harmful interference to radio or television reception, which can be determined by turning the device off and on, the user is encouraged to try to correct the interference by one or more of the following measures:

- Reorient or relocate the receiving antenna.
- Increase the separation between the device and receiver.
- Connect the device into an outlet on a circuit different from that to which the receiver is connected.
- Consult the dealer or an experienced radio/TV technician for help.

Changes or modifications not expressly approved by the party responsible for compliance could void the user's authority to operate the equipment.

This device contains licence-exempt transmitter(s)/receiver(s) that comply with Innovation, Science and Economic Development Canada's licence-exempt RSS(s).

Operation is subject to the following two conditions:

- (1) This device may not cause interference.
- (2) This device must accept any interference, including interference that may cause undesired operation of the device.

Cet appareil contient des émetteurs / récepteurs exemptés de licence conformes aux RSS (RSS) d'Innovation, Sciences et Développement économique Canada.

Le fonctionnement est soumis aux deux conditions suivantes :

- (1) Cet appareil ne doit pas causer d'interférences.
- (2) Cet appareil doit accepter toutes les interférences, y compris celles susceptibles de provoquer un fonctionnement indésirable de l'appareil.

This device complies with Part 15 of the FCC rules. Operation is subject to the following two conditions: 1) this device may not cause harmful interference, and 2) this device must accept any interference received, including interference that may cause undesired operation.