

FCC RADIO TEST REPORT

For
FCC ID: 2AZFV-F100

Report Reference No..... : 21EFSS04025 03291
Date Sample(s) Received..... : 2021-04-08
Date of tested..... : From 2021-04-08 to 2021-05-06
Date of issue..... : 2021-05-06
Testing Laboratory..... : DongGuan ShuoXin Electronic Technology Co., Ltd.
Address..... : Zone A, 1F, No. 6, XinGang Road YuanGang Street, XinAn
District, ChangAn Town, DongGuan City, GuangDong,
China
Applicant's name..... : Chongqing Yuyue Technology Co., Ltd
Address..... : Yugu road No.1 Jiulongpo District Chongqing, China
Manufacturer..... : Chongqing Yuyue Technology Co., Ltd

Test specification:

Test item description..... : YY-F100
Trade Mark..... : N/A
Model/Type reference..... : F100
Ratings..... : I/P: DC 9V

Test Engineer:



Blue Qiu

Responsible Engineer :



Smile Wang

Authorized Signatory:

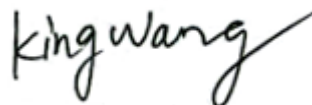

King Wang

TABLE OF CONTENTS

1. Summary of test Standards and results	3
2. General test information	4
2.1. Description of EUT	4
2.2. Accessories of EUT	4
2.3. Assistant equipment used for test.....	4
2.4. Block diagram of EUT configuration for test.....	4
2.5. Test environment conditions.....	5
2.6. Measurement uncertainty.....	5
3. 20dB Occupied Bandwidth.....	6
3.1. Test equipment.....	6
3.2. Block diagram of test setup	6
3.3. Limits	6
3.4 Test Procedure	6
3.5. Test Result	7
3.6. Original test data	7
4. Field Strength of Fundamental And Field Strength of Spurious Emissions.....	8
4.1. Test equipment.....	8
4.2. Block diagram of test setup	9
4.3. Limit.....	10
4.4. Test Procedure	11
4.5. Test result(For 15.205).....	12
4.6 Test result(For 15.231).....	17
5 Duration Time.....	20
5.1 Test equipment.....	20
5.2 Block diagram of test setup.....	20
5.3 Limits	20
5.4 Test Procedure	20
5.5 Test Result	20
5.6 Original test data.....	21
6 Power Line Conducted Emission	22
6.1 Test equipment	22
6.2 Block diagram of test setup.....	22
6.3 Power Line Conducted Emission Limits(Class B)	22
6.4 Test Procedure	23
6.5 Test Result	23
Note2: “----” means peak detection; “-----” mans average detection	23
7. Antenna Requirements	26
7.1. Limit.....	26
7.2. Result	26

TEST REPORT DECLARE

Applicant	:	Chongqing Yuyue Technology Co., Ltd
Address	:	Yugu road No.1 Jiulongpo District Chongqing, China
Equipment under Test	:	YY-F100
Test Model No	:	F100
Manufacturer	:	Chongqing Yuyue Technology Co., Ltd
Address	:	Yugu road No.1 Jiulongpo District Chongqing, China

Test Standard Used: FCC Rules and Regulations Part 15 Subpart C (15.231)

Test procedure used: ANSI C63.10:2013

We Declare:

The equipment described above is tested by DongGuan ShuoXin Electronic Technology Co., Ltd(ATT). and in the configuration tested the equipment complied with the standards specified above. The test results are contained in this test report and DongGuan ShuoXin Electronic Technology Co., Ltd.(ATT) is assumed of full responsibility for the accuracy and completeness of these tests.

ATT is not responsible for the sampling stage, so the results only apply to the sample as received.

ATT's reports apply only to the specific samples tested under conditions. It is manufacture's responsibility to ensure that additional production units of this model are manufactured with the identical electrical and mechanical components. ATT shall have no liability for any declarations, inferences or generalizations drawn by the client or others from ATT issued reports.

1. Summary of test Standards and results

The EUT have been tested according to the applicable standards as referenced below.

Description of Test Item	Standard	Results
20dB Occupied Bandwidth	FCC Part 15.231(c)	PASS
Field Strength of Fundamental and Field Strength of Spurious Emissions	FCC Part 15.209,15.231(b)	PASS
Duration Time	15.231(a)	PASS
AC Line Conducted Emissions	FCC Part 15.207 (a)	PASS
Antenna requirement	FCC Part 15: 15.203	PASS

2. General test information

2.1. Description of EUT

EUT* Name	: YY-F100
Model Number	: F100
EUT function description	: Please reference user manual of this device
Power supply	: DC 9V
Adaptor	: N/A
Radio Technology	: SRD
Operation frequency	: 315 MHz
Modulation	: ASK
Antenna Type	: Internal Antenna, maximum PK gain: 0dBi
Date of Receipt	: 2021/04/08
Sample Type	: Single production

Note: EUT is the ab. of equipment under test.

2.2. Accessories of EUT

Description of Accessories	Manufacturer	Model number or Type	Other
/	/	/	/

2.3. Assistant equipment used for test

Description of Assistant equipment	Manufacturer	Model number or Type	Other

2.4. Block diagram of EUT configuration for test



New battery is used during all test

EUT enters the engineering interface by clicking the system version to control EUT work in test mode as blow table.

2.5. Test environment conditions

During the measurement the environmental conditions were within the listed ranges:

Temperature range:	21-25°C
Humidity range:	40-75%
Pressure range:	86-106kPa

2.6. Measurement uncertainty

Test Item	Uncertainty
Uncertainty for Conduction emission test (9kHz-150kHz)	3.7 dB
Uncertainty for Conduction emission test (150kHz-30MHz)	3.3 dB
Uncertainty for Radiation Emission test (30MHz-200MHz)	4.60 dB (Polarize: V)
	4.60 dB (Polarize: H)
Uncertainty for Radiation Emission test (200MHz-1GHz)	6.10 dB (Polarize: V)
	5.08 dB (Polarize: H)
Uncertainty for Radiation Emission test (1GHz-6GHz)	5.01 dB (Polarize: V)
	5.01 dB (Polarize: H)
Uncertainty for Radiation Emission test (6GHz-18GHz)	5.26 dB (Polarize: V)
	5.26 dB (Polarize: H)
Uncertainty for Radiation Emission test (18GHz-40GHz)	5.06 dB (Polarize: V)
	5.06 dB (Polarize: H)
Uncertainty for radio frequency	$\pm 0.048\text{kHz}$
Uncertainty for conducted RF Power	$\pm 0.32\text{dB}$

Note: This uncertainty represents an expanded uncertainty expressed at approximately the 95% confidence level using a coverage factor of $k=2$.

3. 20dB Occupied Bandwidth

3.1. Test equipment

Item	Equipment	Manufacturer	Model No.	Serial No.	Calibrated until	Calibrated Date
1	Spectrum analyzer	KEYSIGHT	N9010A	MY55150427	2021/05/24	2020/05/25
2	Attenuator	Mini-Circuits	BW-S10W2	101109	N/A	N/A
3	RF Cable	Micable	C10-01-01-1	100309	N/A	N/A

3.2. Block diagram of test setup

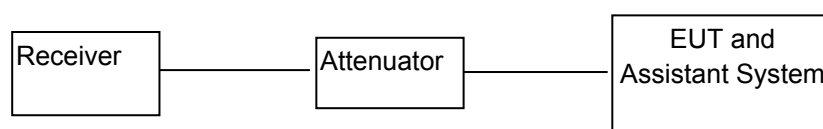

3.3. Limits

The bandwidth of the emission shall be no wider than 0.25% of the center frequency for devices operating above 70 MHz and below 900 MHz. For devices operating above 900 MHz, the emission shall be no wider than 0.5% of the center frequency. Bandwidth is determined at the points 20 dB down from the modulated carrier.

3.4 Test Procedure

- (1) Check the calibration of the measuring instrument using either an internal calibrator or a known signal from an external generator.
- (2) Position the EUT without connection to measurement instrument. Turn on the EUT and connect it to measurement instrument. Then set it to any one convenient frequency within its operating range. Set a reference level on the measuring instrument equal to the highest peak value.
- (3) Measure the frequency difference of two frequencies that were attenuated 20 dB from the reference level. Record the frequency difference as the emission bandwidth.

3.5. Test Result

20dB bandwidth (MHz)	Limit (MHz)	Results
0.01606	0.7875	Pass

Note: Limit= Fundamental frequency×0.25%=303.82×0.25%=0.7875MHz

3.6. Original test data

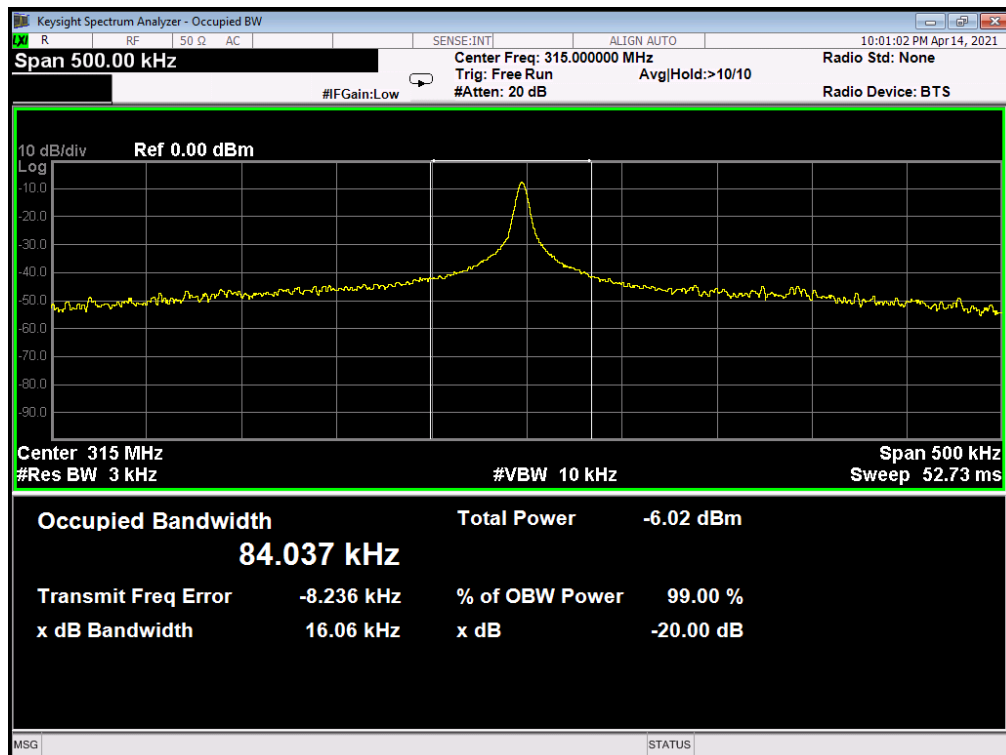

4. Field Strength of Fundamental And Field Strength of Spurious Emissions

4.1. Test equipment

Item	Equipment	Manufacturer	Model No.	Serial No.	Calibrated until
1	EMI Test Receiver	R&S	ESCI	101307	12/12/2021
2	Spectrum Analyzer	Agilent	E4407B	US40240708	11/17/2021
3	Loop antenna	SCHWARZBECK K	FMZB1519	1519-062	12/14/2021
4	Broadband antenna	SCHWARZBECK	VULB9168	VULB9168-192	08/06/2021
5	HORN ANTENNA	SCHWARZBECK	BBHA9120D	9120D 1065	04/20/2022
6	Preamplifier Amplifier	HP	8447F	3113A05680	12/11/2021
7	PRE-AMPLIFIER	CY	EMC011830	980136	12/11/2021
8	RF Cable	R&S	Test Cable 4	4	12/11/2021
9	RF Cable	R&S	Test Cable 5	5	12/11/2021
10	RF Cable	R&S	Test Cable 9	9	04/20/2022
11	RF Cable	R&S	Test Cable 10	10	12/11/2021
12	Measurement Software	Farad	EZ-EMC (Ver.ATT-03A)	N/A	N/A

4.2. Block diagram of test setup

In 3m Anechoic Chamber Test Setup Diagram for below 1GHz

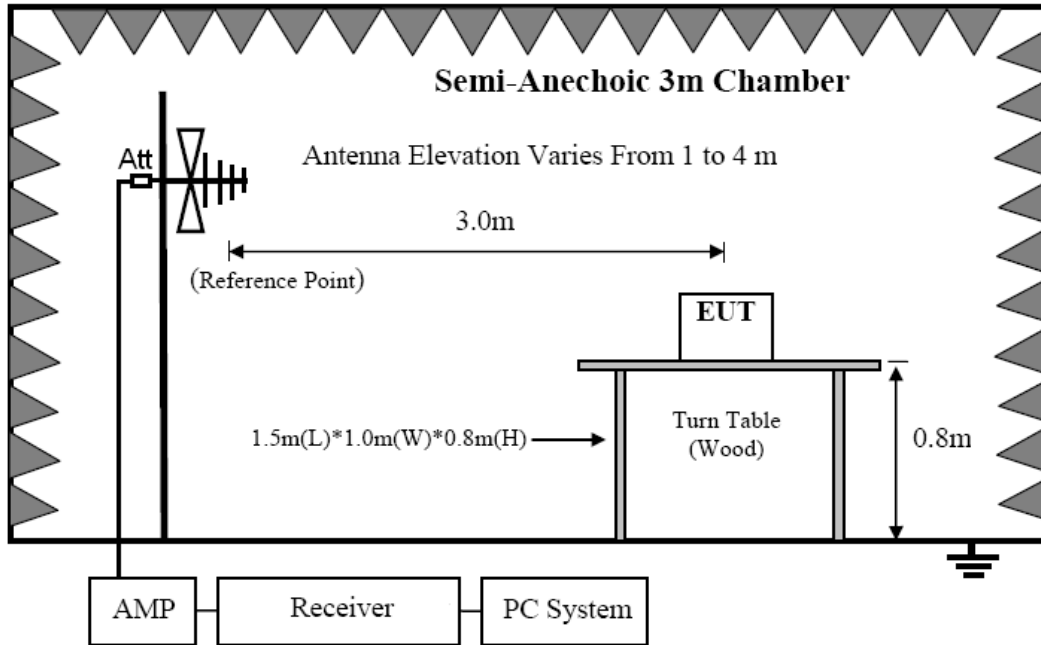

In 3m Anechoic Chamber Test Setup Diagram for frequency above 1GHz

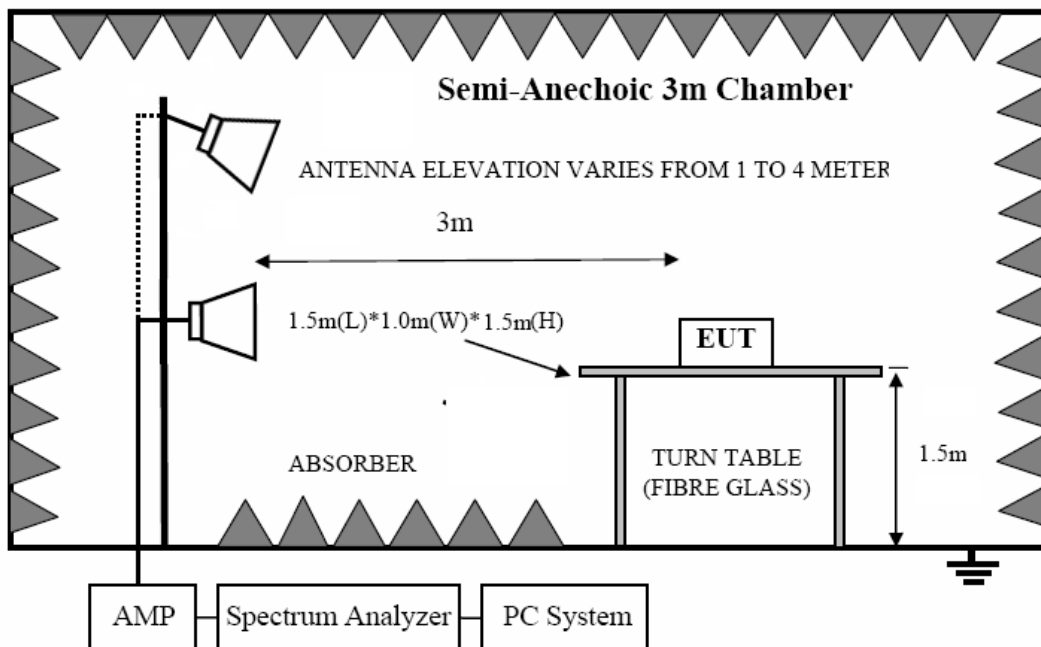

Note: For harmonic emissions test a appropriate high pass filter was inserted in the input port of AMP.

4.3. Limit

FCC 15.209 Limit

FREQUENCY MHz	DISTANCE Meters	FIELD STRENGTHS LIMIT	
		$\mu\text{V}/\text{m}$	$\text{dB}(\mu\text{V})/\text{m}$
30 ~ 88	3	100	40.0
88 ~ 216	3	150	43.5
216 ~ 960	3	200	46.0
960 ~ 1000	3	500	54.0
Above 1000	3	74.0 $\text{dB}(\mu\text{V})/\text{m}$ (Peak) 54.0 $\text{dB}(\mu\text{V})/\text{m}$ (Average)	

FCC 15.231(a) limit

Fundamental Frequency (MHz)	Field strength of fundamental (millivolts/meter)	Field strength of spurious emissions (millivolts/meter)
40.66-40.70	2250	225
70-130	1250	125
130-174	1250 to 3750(see Note 1)	125 to 375(see Note 1)
174-260	3750	375
260-470	3750 to 12500(see Note 1)	375 to 1250(see Note 1)
Above 470	12500	1250

Note 1: For 130MHz-174MHz: Field Strength($\mu\text{V}/\text{m}$)= $(56.82*f)-6136$

For 260MHz-470MHz: Field Strength($\mu\text{V}/\text{m}$)= $(41.67*f)-7083$

$\text{dB}\mu\text{V}/\text{m}=20\log\mu\text{V}/\text{m}$

Intentional radiators operating under the provisions of this section shall demonstrate compliance with the limits on the field strength of emissions, as shown in the above table, based on the average value of the measured emissions.

315MHz limit= $20\log(41.67*315)-7083 \approx 75.6\text{dB}\mu\text{V}/\text{m}$

$\text{AVG}=\text{peak}+20\log(\text{Duty Cycle})$

4.4. Test Procedure

- (1) EUT was placed on a non-metallic table, 80 cm above the ground plane inside a semi-anechoic chamber.
- (2) Setup EUT and assistant system according clause 2.4 and 8.2
- (3) Test antenna was located 3m from the EUT on an adjustable mast. Below pre-scan procedure was first performed in order to find prominent radiated emissions.
 - (a) Change work frequency or channel of device if practicable.
 - (b) Change modulation type of device if practicable.
 - (c) Change power supply range from 85% to 115% of the rated supply voltage
 - (d) Rotated EUT though three orthogonal axes to determine the attitude of EUT arrangement produces highest emissions
- (4) Spectrum frequency from 9MHz to 4GHz (tenth harmonic of fundamental frequency) was investigated, and no any obvious emission were detected from 9KHz to 30MHz, so below final test was performed with frequency range from 30MHz to 4GHz.
- (5) For final emissions measurements at each frequency of interest, the EUT were rotated and the antenna height was varied between 1m and 4m in order to maximize the emission. Measurements in both horizontal and vertical polarities were made and the data was recorded. In order to find the maximum emission, the relative positions of equipments and all of the interface cables were changed according to ANSI C63.10 2013 on Radiated Emission test.
- (6) For emissions from 30MHz to 1GHz, Quasi-Peak values were measured with EMI Receiver and the bandwidth of Receiver is 120 KHz.
- (7) For emissions above 1GHz, both Peak and Average level were measured with Spectrum Analyzer, and the RBW is set at 1MHz, VBW is set at 3MHz for Peak measure, Detector is at PK; RBW is set at 1MHz, VBW is set at 3MHz for Average measure, Detector is at RMS..
- (8) For Field Strength of Fundamental were measured with Spectrum Analyzer, and the RBW is set at above 99% Occupied Bandwidth , VBW is set at equal to RBW for Peak measure, Detector is at PK

4.5. Test result(For 15.205)

Below 30M

EUT:	YY-F100	Model No.:	F100
Temperature:	24°C	Relative Humidity:	55%
Distance:	3m	Test Power:	DC 9V
Polarization:	--	Test Result:	Pass
Test Mode:	Keeping TX mode	Test By:	Smile

Freq.	Reading	Limit	Margin	State
(MHz)	(dBuV/m)	(dBuV/m)	(dB)	P/F
--	--	--	--	P
--	--	--	--	P

Note:

The amplitude of spurious emissions which are attenuated by more than 20dB below the permissible value has no need to be reported.

Distance extrapolation factor = $20 \log(\text{specific distance}/\text{test distance})(\text{dB})$;

Limit line = specific limits(dBuv) + distance extrapolation factor

Between 30M – 1000 MHz

EUT:	YY-F100	Model No.:	F100
Temperature:	23	Relative Humidity:	54%
Distance:	3m	Test Power:	DC 9V
Polarization:	Vertical	Test Result:	Pass
Test Time:	2021-4-15	Test By:	Blue
Standard:	(RE)FCC PART 15 class B 3m		
Test Mode:	TX		
Note:			

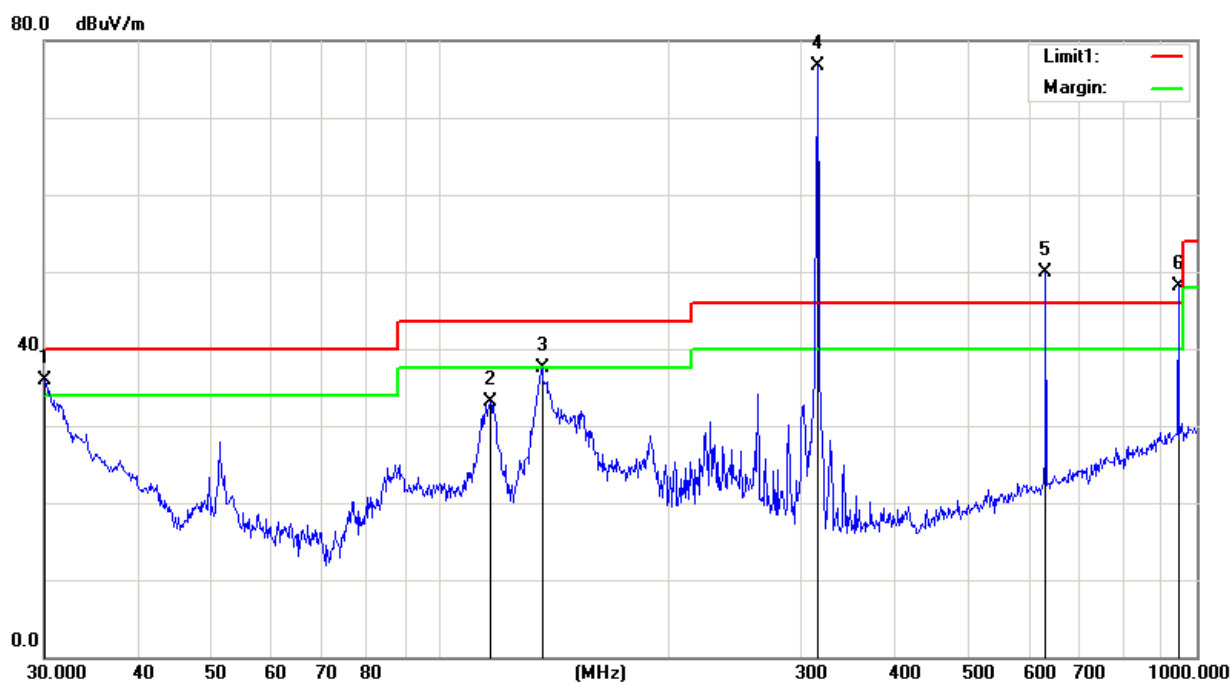

No.	Frequency (MHz)	Reading (dBuV/m)	Correct Factor (dB/m)	Result (dBuV/m)	Limit (dBuV/m)	Margin (dB)	Remark
1	30.1051	47.06	-11.22	35.84	40.00	-4.16	peak
2	116.5400	46.42	-13.31	33.11	43.50	-10.39	peak
3	136.4598	49.79	-12.31	37.48	43.50	-6.02	peak
4	315.4806	85.33	-8.56	76.77			peak
5	631.6884	52.68	-2.82	49.86			peak
6	945.4398	44.26	3.92	48.18			peak

The test result is calculated as the following:

- (1) Result = Reading + Correct Factor
- (2) Correct Factor = Antenna Factor + Cable Loss – Amplifier Gain + Attenuator
- (3) Margin = Result - Limit

EUT:	YY-F100	Model No.:	F100
Temperature:	23	Relative Humidity:	54%
Distance:	3m	Test Power:	DC 9V
Polarization:	Horizontal	Test Result:	Pass
Test Time:	2021-4-15	Test By:	Blue
Standard:	(RE)FCC PART 15 class B 3m		
Test Mode:	TX		
Note:			

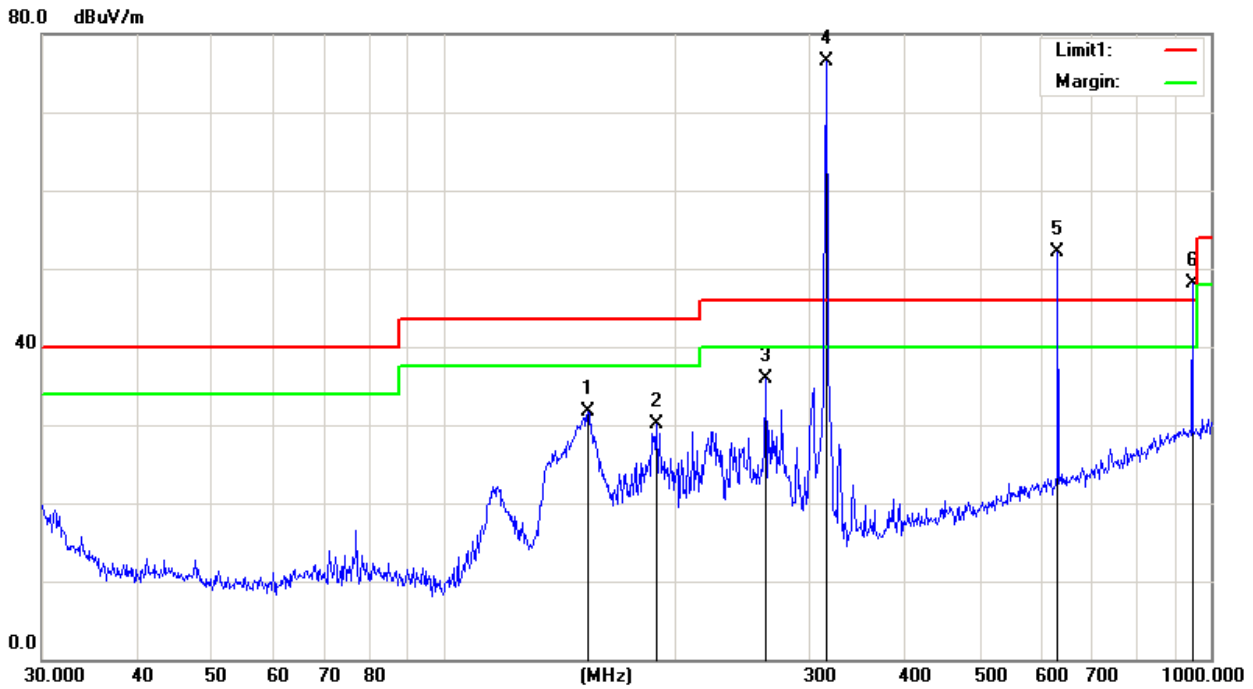

No.	Frequency (MHz)	Reading (dBuV/m)	Correct Factor(dB/m)	Result (dBuV/m)	Limit (dBuV/m)	Margin (dB)	Remark
1	154.2786	44.19	-12.56	31.63	43.50	-11.87	peak
2	189.7384	39.55	-9.41	30.14	43.50	-13.36	peak
3	262.8955	40.61	-4.80	35.81	46.00	-10.19	peak
4	315.4808	85.02	-8.46	76.56			peak
5	631.6884	54.90	-2.82	52.08			peak
6	945.4399	44.16	3.92	48.08			peak

The test result is calculated as the following:

- (1) Result = Reading + Correct Factor
- (2) Correct Factor = Antenna Factor + Cable Loss – Amplifier Gain + Attenuator
- (3) Margin = Result - Limit

Between 1000M – 4000 MHz

EUT:	YY-F100	Model No.:	F100
Temperature:	23	Relative Humidity:	54%
Distance:	3m	Test Power:	DC 9V
Polarization:	Vertical	Test Result:	Pass
Test Time:	2021-5-4	Test By:	Blue qiu
Standard:	(RE)FCC PART 15 class B 3m 1-6G PK		
Test Mode:	TX		
Note:			

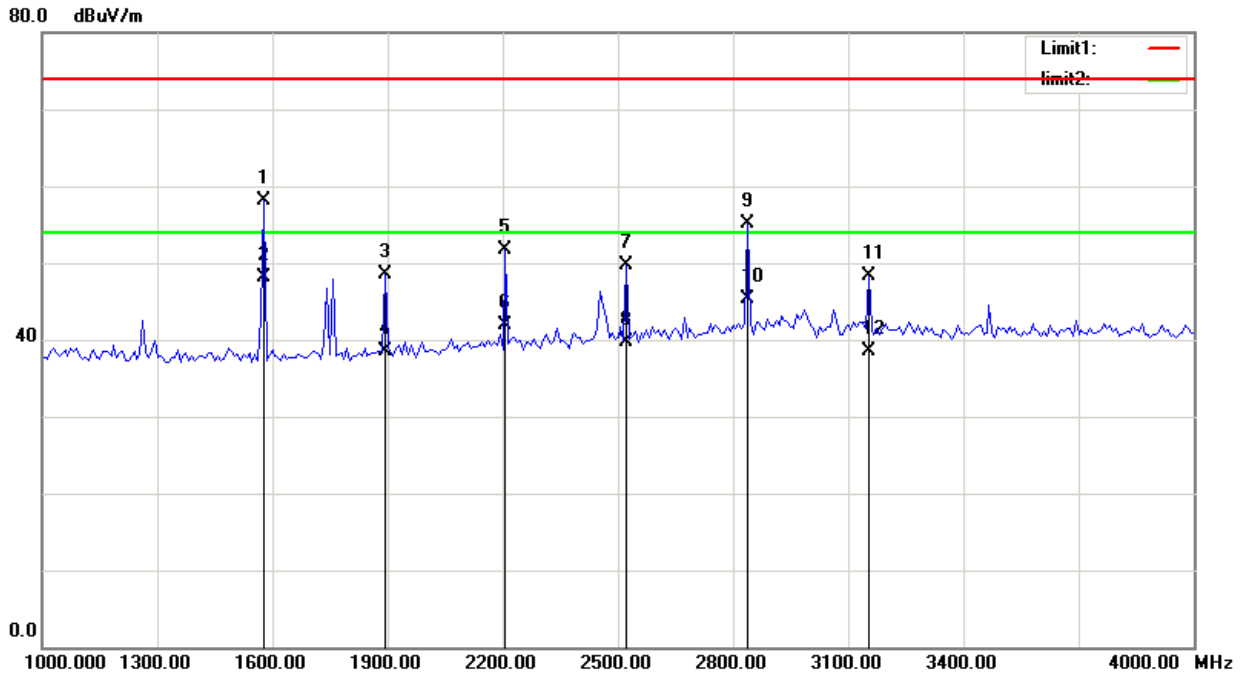

No.	Frequency (MHz)	Reading (dBuV/m)	Correct Factor (dB/m)	Result (dBuV/m)	Limit (dBuV/m)	Margin (dB)	Remark
1	1577.500	72.59	-14.53	58.06	74.00	-15.94	peak
2	1577.500			48.20	54.00	-5.80	AVG
3	1892.500	62.25	-13.80	48.45	74.00	-25.55	peak
4	1892.500			38.59	54.00	-15.41	AVG
5	2207.500	64.39	-12.62	51.77	74.00	-22.23	peak
6	2207.500			41.91	54.00	-12.09	AVG
7	2522.500	61.24	-11.59	49.65	74.00	-24.35	peak
8	2522.500			39.79	54.00	-14.21	AVG
9	2837.500	65.76	-10.63	55.13	74.00	-18.87	peak
10	2837.500			45.27	54.00	-8.73	AVG
11	3152.500	58.48	-10.13	48.35	74.00	-25.65	peak
12	3152.500			38.49	54.00	-15.51	AVG

The test result is calculated as the following:

- (1) Result = Reading + Correct Factor
- (2) Correct Factor = Antenna Factor + Cable Loss – Amplifier Gain + Attenuator
- (3) Margin = Result - Limit

EUT:	YY-F100	Model No.:	F100
Temperature:	23	Relative Humidity:	54%
Distance:	3m	Test Power:	DC 9V
Polarization:	Horizontal	Test Result:	Pass
Test Time:	2021-5-4	Test By:	Blue qiu
Standard:	(RE)FCC PART 15 class B 3m 1-6G PK		
Test Mode:	TX		
Note:			

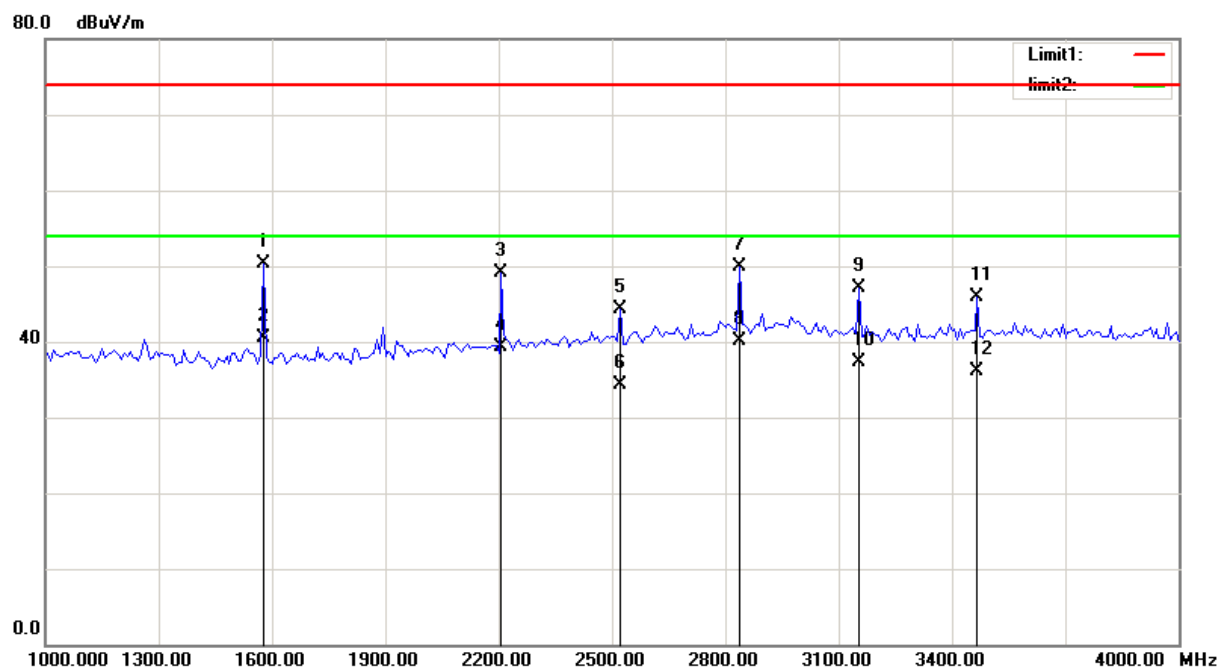

No.	Frequency (MHz)	Reading (dBuV/m)	Correct Factor (dB/m)	Result (dBuV/m)	Limit (dBuV/m)	Margin (dB)	Remark
1	1577.500	64.80	-14.53	50.27	74.00	-23.73	peak
2	1577.500			40.41	54.00	-13.59	AVG
3	2207.500	61.79	-12.62	49.17	74.00	-24.83	peak
4	2207.500			39.31	54.00	-14.69	AVG
5	2522.500	55.81	-11.59	44.22	74.00	-29.78	peak
6	2522.500			34.36	54.00	-19.64	AVG
7	2837.500	60.59	-10.63	49.96	74.00	-24.04	peak
8	2837.500			40.10	54.00	-13.90	AVG
9	3152.500	57.22	-10.13	47.09	74.00	-26.91	peak
10	3152.500			37.23	54.00	-16.77	AVG
11	3467.500	56.00	-10.12	45.88	74.00	-28.12	peak
12	3467.500			36.02	54.00	-17.98	AVG

The test result is calculated as the following:

- (1) Result = Reading + Correct Factor
- (2) Correct Factor = Antenna Factor + Cable Loss – Amplifier Gain + Attenuator
- (3) Margin = Result - Limit

4.6 Test result(For 15.231)

EUT:	YY-F100	Model No.:	F100
Temperature:	24	Relative Humidity:	55%
Distance:	3m	Test Power:	DC 9V
Polarization:	Vertical	Test Result:	Pass
Test Time:	2021-4-15	Test By:	Blue Qiu
Standard:	FCC PART 15 C 30M-1G PEAK		
Test Mode:	TX		
Note:			

No.	Frequency (MHz)	Reading (dBuV/m)	Correct Factor(dB/m)	Result (dBuV/m)	Limit (dBuV/m)	Margin (dB)	Remark
1	315.4806	85.33	-8.56	76.77	95.6	-18.83	peak
2	315.4806			66.91	75.6	-8.69	AVG
3	631.6884	52.68	-2.82	49.86	75.6	-25.74	peak
4	631.6884			40.00	55.6	-15.60	AVG
5	945.4398	44.26	3.92	48.18	75.6	-27.42	peak
6	945.4398			38.32	55.6	-17.28	AVG

The test result is calculated as the following:

- (1) Result = Reading + Correct Factor
- (2) Correct Factor = Antenna Factor + Cable Loss – Amplifier Gain + Attenuator
- (3) Margin = Result - Limit

Note: AVG=peak+20log (Duty Cycle)

Duty Cycle=on time/Total Time=(0.84ms*6+0.3*19)/33.43ms≈0.321=32.1%

AVG=peak+20log0.233=peak-9.86

EUT:	YY-F100	Model No.:	F100
Temperature:	24	Relative Humidity:	55%
Distance:	3m	Test Power:	DC 9V
Polarization:	Horizontal	Test Result:	Pass
Test Time:	2021-4-15	Test By:	Blue Qiu
Standard:	FCC PART 15 C 30M-1G PEAK		
Test Mode:	TX		
Note:			

No.	Frequency (MHz)	Reading (dBuV/m)	Correct Factor(dB/m)	Result (dBuV/m)	Limit (dBuV/m)	Margin (dB)	Remark
1	315.4806	85.02	-8.46	76.56	95.6	-19.04	peak
2	315.4806			66.70	75.6	-8.90	AVG
3	631.6884	54.90	-2.82	52.08	75.6	-23.52	peak
4	631.6884			42.22	55.6	-13.38	AVG
5	945.4397	44.16	3.92	48.08	75.6	-27.52	peak
6	945.4397			38.22	55.6	-17.38	AVG

The test result is calculated as the following:

- (1) Result = Reading + Correct Factor
- (2) Correct Factor = Antenna Factor + Cable Loss – Amplifier Gain + Attenuator
- (3) Margin = Result - Limit

Note: $AVG = peak + 20 \log(\text{Duty Cycle})$

Duty Cycle = on time / Total Time = $(0.84ms * 6 + 0.3 * 19) / 33.43ms = 0.321 = 32.1\%$

$AVG = peak + 20 \log 0.233 = peak - 9.86$

Duty Cycle

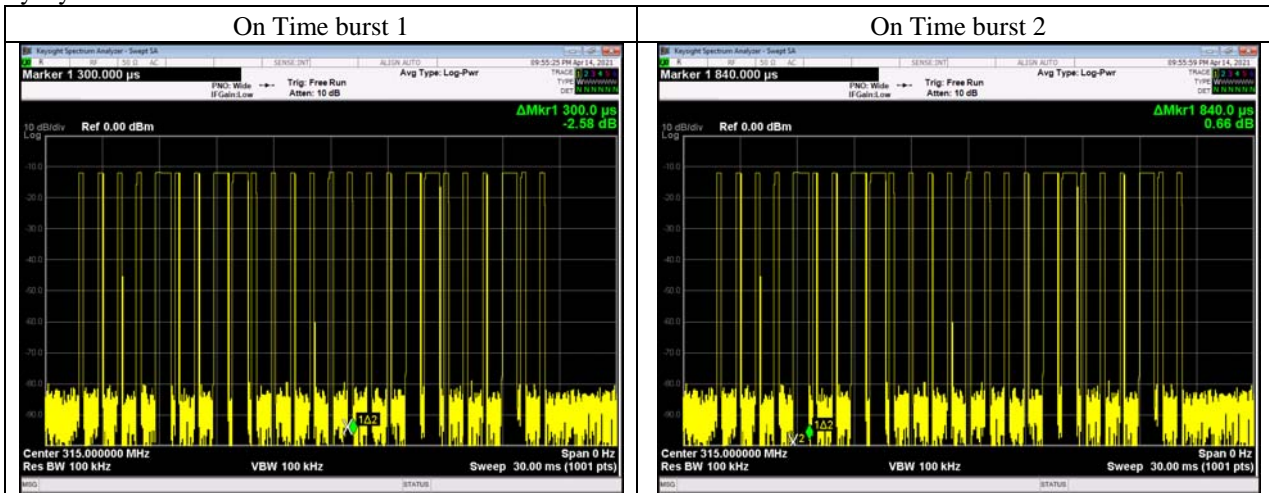

Total Time

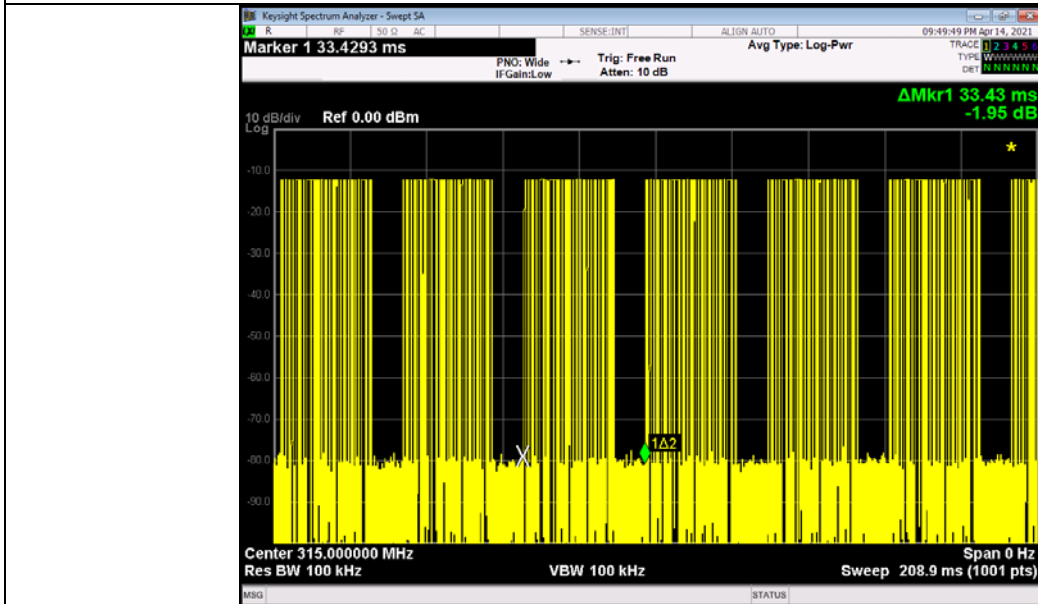

5 Duration Time

5.1 Test equipment

Item	Equipment	Manufacturer	Model No.	Serial No.	Calibrated until	Calibrated Date
1	Spectrum analyzer	KEYSIGHT	N9010A	MY55150427	2021/05/24	2020/05/25
2	Attenuator	Mini-Circuits	BW-S10W2	101109	N/A	N/A
3	RF Cable	Micable	C10-01-01-1	100309	N/A	N/A

5.2 Block diagram of test setup

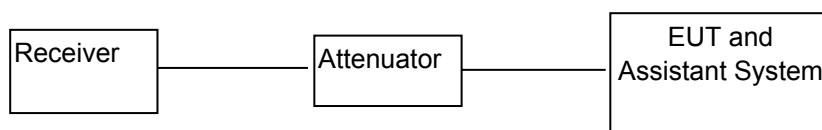

5.3 Limits

Not more than 5 seconds

5.4 Test Procedure

1. According to the follow Test-setup, keep the relative position between the artificial antenna and the EUT.
2. Set the EUT to proper test channel.
3. Single scan the transmission, and read the transmission time.

5.5 Test Result

Duration time (second)	Limit (second)	Result
1.219	5	pass

5.6 Original test data

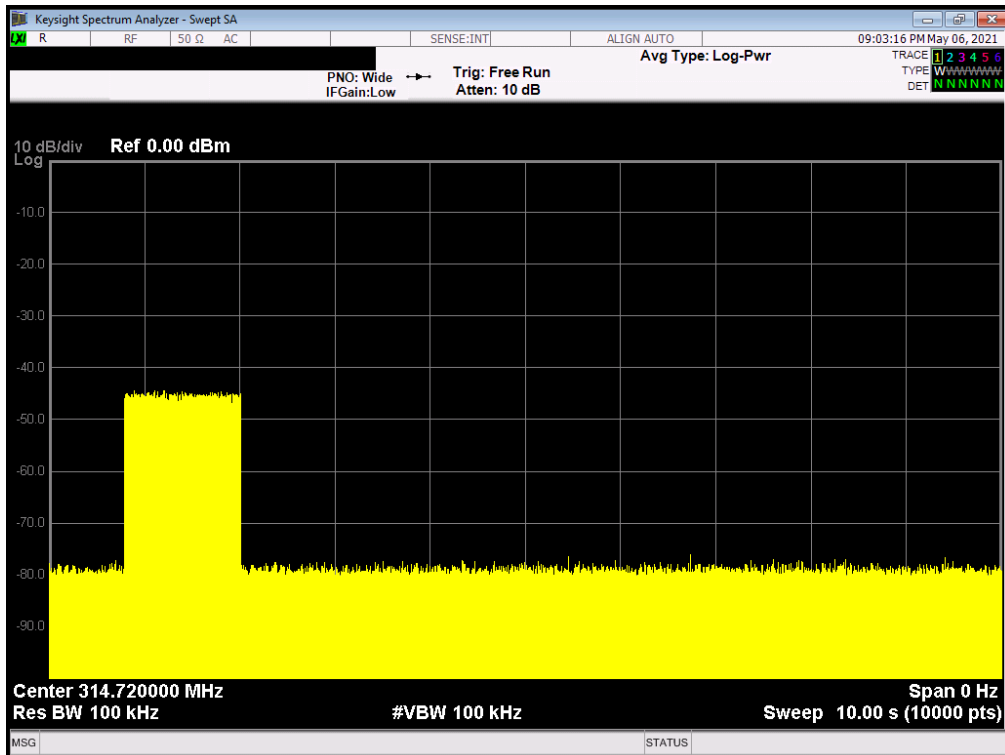
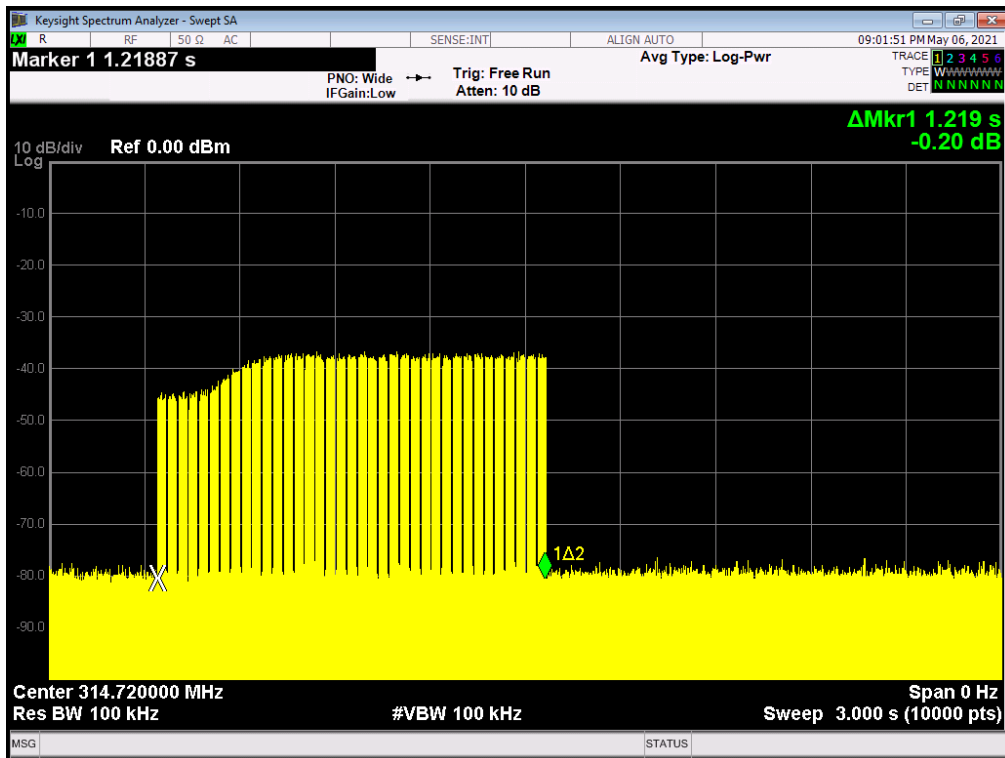

6 Power Line Conducted Emission

6.1 Test equipment

Item	Kind of Equipment	Manufacturer	Type No.	Serial No.	Calibrated until
1	Pulse Limiter	MTS-systemtechnik	MTS-IMP-136	261115-010-0024	12/11/2021
2	EMI Test Receiver	R&S	ESCI	101308	12/12/2021
3	LISN	AFJ	LS16	16011103219	06/09/2021
4	LISN	Schwarzbeck	NSLK 8127	8127-432	12/11/2021
5	Measurement Software	Farad	EZ-EMC (Ver.ATT-03A)	N/A	N/A

6.2 Block diagram of test setup

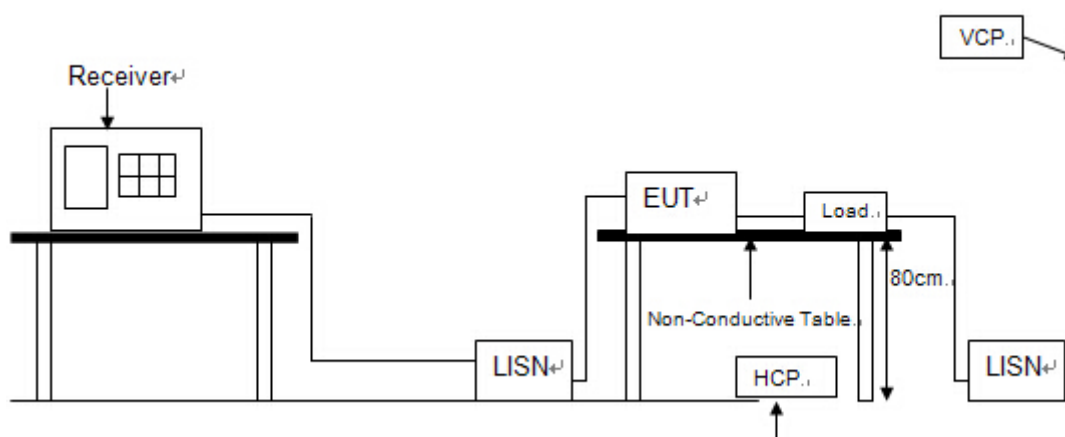

6.3 Power Line Conducted Emission Limits(Class B)

Frequency	Quasi-Peak Level dB(μ V)	Average Level dB(μ V)
150kHz ~ 500kHz	66 ~ 56*	56 ~ 46*
500kHz ~ 5MHz	56	46
5MHz ~ 30MHz	60	50

Note 1: * Decreasing linearly with logarithm of frequency.

Note 2: The lower limit shall apply at the transition frequencies.

6.4 Test Procedure

The EUT and Support equipment, if needed, were put placed on a non-metallic table, 80cm above the ground plane.

Configuration EUT to simulate typical usage as described in clause 2.4 and test equipment as described in clause 10.2 of this report.

All I/O cables were positioned to simulate typical actual usage as per ANSI C63.4.

All support equipment power received from a second LISN.

Emissions were measured on each current carrying line of the EUT using an EMI Test Receiver connected to the LISN powering the EUT.

The Receiver scanned from 150 kHz to 30MHz for emissions in each of the test modes.

During the above scans, the emissions were maximized by cable manipulation.

The test mode(s) described in clause 2.4 were scanned during the preliminary test.

After the preliminary scan, we found the test mode producing the highest emission level.

The EUT configuration and worse cable configuration of the above highest emission levels were recorded for reference of the final test.

EUT and support equipment were set up on the test bench as per the configuration with highest emission level in the preliminary test.

A scan was taken on both power lines, Neutral and Line, recording at least the six highest emissions.

Emission frequency and amplitude were recorded into a computer in which correction factors were used to calculate the emission level and compare reading to the applicable limit.

The test data of the worst-case condition(s) was recorded.

The bandwidth of test receiver is set at 9 KHz.

6.5 Test Result

PASS. (See below detailed test result)

Note1: All emissions not reported below are too low against the prescribed limits.

Note2: “----” means peak detection; “----” mans average detection

EUT:	YY-F100	Model No.:	F100
Temperature:	23.1	Relative Humidity:	52%
		Test Power:	AC 120V/60Hz
Probe:	L1	Test Result:	Pass
Test Time:	2021-5-5	Test By:	Blue Qiu
Standard:	(CE)FCC PART 15 class B_QP		
Test Mode:	TX		
Note:			

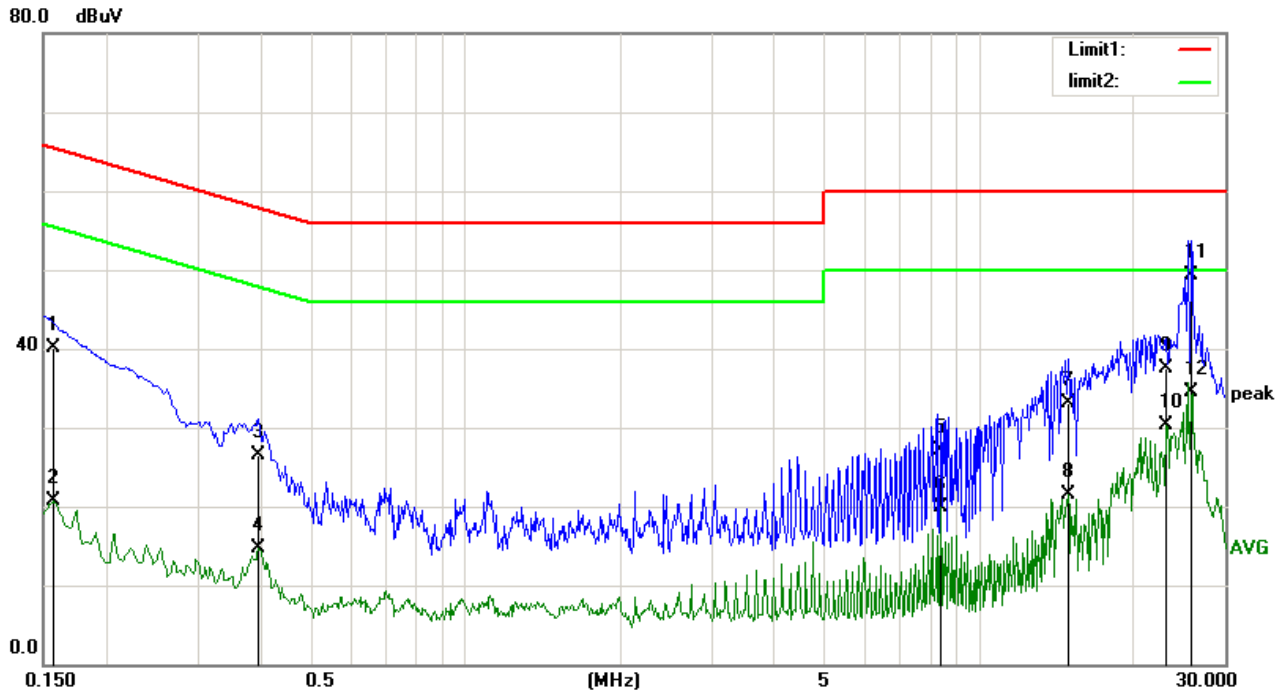

No.	Frequency (MHz)	Reading (dBuV)	Correct Factor(dB)	Result (dBuV)	Limit (dBuV)	Margin (dB)	Remark
1	0.1580	28.66	11.47	40.13	65.56	-25.43	QP
2	0.1580	9.17	11.47	20.64	55.56	-34.92	AVG
3	0.3940	16.15	10.41	26.56	57.98	-31.42	QP
4	0.3940	4.29	10.41	14.70	47.98	-33.28	AVG
5	8.4018	16.90	10.20	27.10	60.00	-32.90	QP
6	8.4018	9.62	10.20	19.82	50.00	-30.18	AVG
7	14.8299	22.99	10.21	33.20	60.00	-26.80	QP
8	14.8299	11.25	10.21	21.46	50.00	-28.54	AVG
9	23.0620	27.27	10.21	37.48	60.00	-22.52	QP
10	23.0620	20.03	10.21	30.24	50.00	-19.76	AVG
11	25.8100	39.09	10.21	49.30	60.00	-10.70	QP
12	25.8100	24.29	10.21	34.50	50.00	-15.50	AVG

The test result is calculated as the following:

- (1) Result = Reading + Correct Factor
- (2) Correct Factor = (LISN, ISN, PLC or Current Probe) Factor + Cable Loss +Attenuator
- (3) Margin = Result - Limit

EUT:	YY-F100	Model No.:	F100
Temperature:	23.1	Relative Humidity:	52%
		Test Power:	AC 120V/60Hz
Probe:	N	Test Result:	Pass
Test Time:	2021-5-5	Test By:	Blue Qiu
Standard:	(CE)FCC PART 15 class B_QP		
Test Mode:	TX		
Note:			

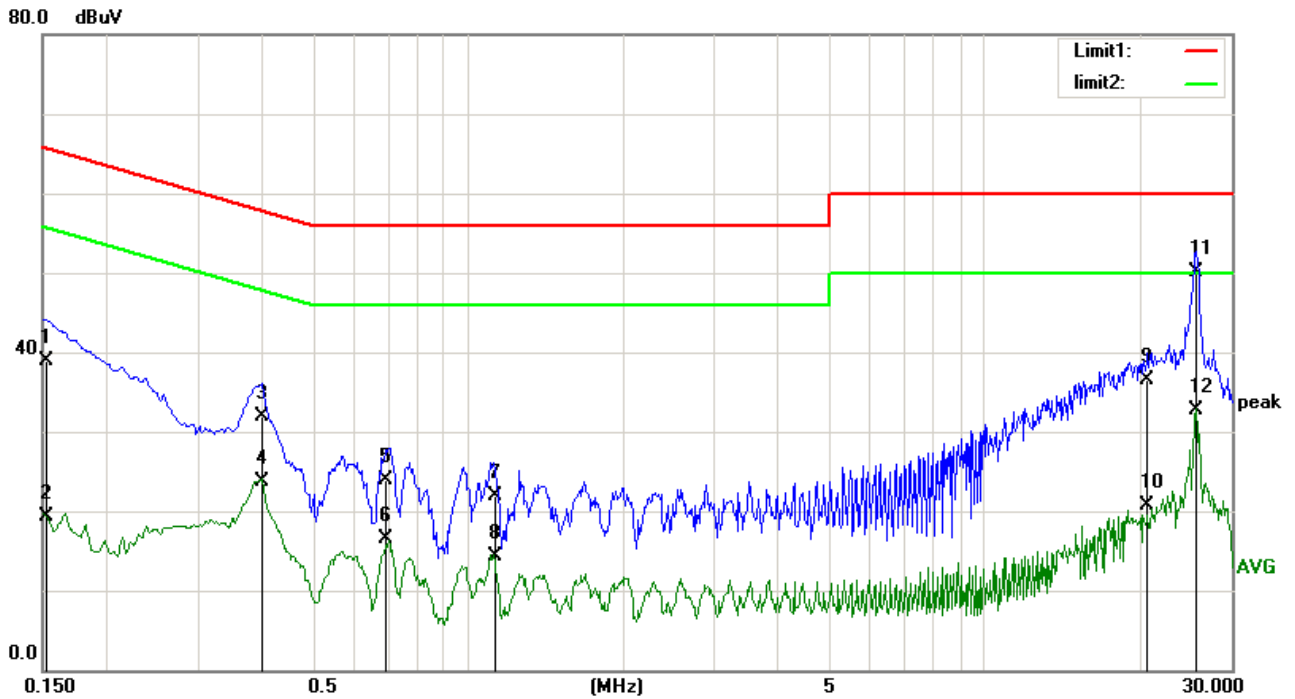

No.	Frequency (MHz)	Reading (dBuV)	Correct Factor(dB)	Result (dBuV)	Limit (dBuV)	Margin (dB)	Remark
1	0.1524	27.33	11.51	38.84	65.86	-27.02	QP
2	0.1524	7.79	11.51	19.30	55.86	-36.56	AVG
3	0.3983	21.53	10.40	31.93	57.89	-25.96	QP
4	0.3983	13.21	10.40	23.61	47.89	-24.28	AVG
5	0.6956	13.58	10.24	23.82	56.00	-32.18	QP
6	0.6956	6.29	10.24	16.53	46.00	-29.47	AVG
7	1.1279	11.61	10.21	21.82	56.00	-34.18	QP
8	1.1279	4.11	10.21	14.32	46.00	-31.68	AVG
9	20.6594	26.21	10.22	36.43	60.00	-23.57	QP
10	20.6594	10.46	10.22	20.68	50.00	-29.32	AVG
11	25.6587	39.94	10.21	50.15	60.00	-9.85	QP
12	25.6587	22.41	10.21	32.62	50.00	-17.38	AVG

The test result is calculated as the following:

- (1) Result = Reading + Correct Factor
- (2) Correct Factor = (LISN, ISN, PLC or Current Probe) Factor + Cable Loss +Attenuator
- (3) Margin = Result – Limit

7. Antenna Requirements

7.1. Limit

For intentional device, according to FCC 47 CFR Section 15.203, an intentional radiator shall be designed to ensure that no antenna other than that furnished by the responsible party shall be used with the device. And according to FCC 47 CFR Section 15.231 (b), if transmitting antennas of directional gain greater than 6dBi are used, the power shall be reduced by the amount in dB that the directional gain of the antenna exceeds 6dBi.

7.2. Result

The antennas used for this product are built-in undetachable dipole antenna and that no antenna other than that furnished by the responsible party shall be used with the device, the maximum peak gain of the transmit antenna is only 0dBi. The EUT has an internal antenna, the directional gain of antenna is 1 dBi, and the antenna connector is designed with permanent attachment and no consideration of replacement. Therefore the EUT is considered sufficient to comply with the provision.